



TEST REPORT

Report Reference No...... : **TRE1405002001** R/C.....:16058
FCC ID..... : **YAMRD62XUHF**
Applicant's name..... : **Hytera Communications Co.,Ltd**
 Address..... : HYT Tower, Hi-tech Industrial Park North,Nanshan District, Shenzhen China
Manufacturer.....: **Hytera Communications Co.,Ltd**
 Address..... : HYT Tower, Hi-tech Industrial Park North,Nanshan District, Shenzhen China
Test item description : **Digital Wall-mounted Repeater**
 Trade Mark : 
 Model/Type reference.....: RD620 U2
 Listed Model : RD622 U2, RD625 U2, RD626 U2, RD628 U2
Standard : **FCC Part 90/FCC Part 2/ FCC Part 15B**
 Date of receipt of test sample.....: May 10, 2014
 Date of testing.....: May 10, 2014- Jun 05, 2014
 Date of issue.....: Jun 05, 2014
Result.....: **PASS**

Compiled by
 (position+printed name+signature)...: File administrators Yuchao Wang 
 Supervised by
 (position+printed name+signature)...: Project Engineer Jerome Luo 
 Approved by
 (position+printed name+signature)...: RF Manager Hans Hu 

Testing Laboratory Name : **Shenzhen Huatongwei International Inspection Co., Ltd**
 Address.....: Keji Nan No.12 Road, Hi-tech Park, Shenzhen, China

Shenzhen Huatongwei International Inspection Co., Ltd. All rights reserved.

This publication may be reproduced in whole or in part for non-commercial purposes as long as the Shenzhen Huatongwei International Inspection Co., Ltd is acknowledged as copyright owner and source of the material. Shenzhen Huatongwei International Inspection Co., Ltd takes no responsibility for and will not assume liability for damages resulting from the reader's interpretation of the reproduced material due to its placement and context.

1.	<u>TEST STANDARDS AND TEST DESCRIPTION</u>	3
1.1.	Test Standards	3
1.2.	Test Description	3
2.	<u>SUMMARY</u>	4
2.1.	Client Information	4
2.2.	Product Description	4
2.3.	EUT operation mode	5
2.4.	EUT configuration	5
2.5.	Modifications	5
3.	<u>TEST ENVIRONMENT</u>	6
3.1.	Address of the test laboratory	6
3.2.	Test Facility	6
3.3.	Environmental conditions	7
3.4.	Statement of the measurement uncertainty	7
3.5.	Equipments Used during the Test	8
4.	<u>TEST CONDITIONS AND RESULTS</u>	10
4.1.	Conducted Emissions Test	10
4.2.	Occupied Bandwidth and Emission Mask Test	20
4.3.	Transmitter Radiated Spurious Emssion	31
4.4.	Spurious Emssion on Antenna Port	35
4.5.	Modulation Charcateristics	43
4.6.	Frequency Stability Test	47
4.7.	Maximum Transmitter Power	50
4.8.	Transmitter Frequency Behavior	59
5.	<u>TEST SETUP PHOTOS OF THE EUT</u>	63
6.	<u>EXTERNAL AND INTERNAL PHOTOS OF THE EUT</u>	65

1. TEST STANDARDS AND TEST DESCRIPTION

1.1. Test Standards

The tests were performed according to following standards:

[FCC Rules Part 90 :2013](#): Private land mobile radio services.

[TIA/EIA 603 D:June 2010](#): Land Mobile FM or PM Communications Equipment Measurement and Performance Standards.

[FCC Part 15 Subpart B:2013](#) - Unintentional Radiators

[FCC Part 2: 2013](#) Frequency allocations and radio treaty matters, general rules and regulations.

1.2. Test Description

Test specification clause	Test case	Verdict
FCC Part 15.107	Conducted Emission	PASS
FCC Part 90.205	Maximum Transmitter Power	PASS
FCC Part 90.207	Modulation Characteristic	PASS
FCC Part 90.209	Occupied Bandwidth	PASS
FCC Part 90.210	Emission Mask	PASS
FCC Part 90.213	Frequency Stability	PASS
FCC Part 90.214	Transmitter Frequency Behavior	PASS
FCC Part 90.210	Transmitter Radiated Spurious Emssion	PASS
FCC Part 90.210	Spurious Emssion On Antenna Port	PASS
FCC Part 15.109	Receiver Radiated Spurious Emssion	N/A [2]
FCC Part 15.109	Receiver Conducted Spurious Emssion	N/A [2]

Remark:1.The product was continuous transmitter after receive signal to activate transmitter;

2.The product can not state only receiver mode and the product was continuous transmitter after receive signal to activate transmitter;

3.The measurement uncertainty is not included in the test result.

2. SUMMARY

2.1. Client Information

Applicant:	Hytera Communications Co.,Ltd
Address:	HYT Tower, Hi-tech Industrial Park North,Nanshan District, Shenzhen China
Manufacturer:	Hytera Communications Co.,Ltd
Address:	HYT Tower, Hi-tech Industrial Park North,Nanshan District, Shenzhen China

2.2. Product Description

Name of EUT	Digital Wall-mounted Repeater	
Trade Mark:		
Model/Type reference:	RD620 U2	
Listed Model:	RD622 U2, RD625 U2, RD626 U2, RD628 U2	
Operation Frequency:	From 450 MHz to 527 MHz	
Rated Output Power:	25 Watts(43.98dBm)/1 Watts(30.00dBm)	
Support data rate:	9.6kbps	
Modulation Type:	FM for Analog Voice	
	4FSK for Digital Voice / Digital Data	
Channel Separation:	Analog Voice	12.5KHz
	Digital Voice/Data	12.5KHz
	Digital Data	12.5KHz
Antenna Type:	External	

Note: The product has the same digital working characters when operating in both two digitized voice/data mode. So only one set of test results for digital modulation modes are provided in this test report.

Test frequency list

Modulation Type	Test Channel	Test Frequency (MHz)
Analog/FM Digital/4FSK	Lowest channel	450.5
	Middle channel	488.5
	Highest channel	526.5

Note:

In section 15.31(m), regards to the operating frequency range over 10 MHz, the Lowest frequency, the middle frequency, and the highest frequency of channel were selected to perform the test, please see the above listed frequency for testing.

2.3. EUT operation mode

The EUT has been tested under typical operating condition and The Transmitter was operated in the normal operating mode. The TX frequency was fixed which was for the purpose of the measurements.

Test mode No.	Description of operation mode	Additional information
Op 1	FM+BW12.5KHz+TX	The equipment is set with FM modulation and 12.5KHz bandwidth for transmitter at maximum rated power, powered by AC 120V/60Hz
Op 2	FM+BW12.5KHz+TX	The equipment is set with FM modulation and 12.5KHz bandwidth at maximum rated power for transmitter, powered by DC 13.60V
Op 3	FM+BW12.5KHz+TX	The equipment is set with FM modulation and 12.5KHz bandwidth for transmitter at minimum rated power, powered by AC 120V/60Hz
Op 4	FM+BW12.5KHz+TX	The equipment is set with FM modulation and 12.5KHz bandwidth at minimum rated power for transmitter, powered by DC 13.60V
Op 5	4FSK+BW12.5KHz+TX	The equipment is set with 4FSK modulation and 12.5KHz bandwidth at maximum rated power for transmitter, powered by AC 120V/60Hz
Op 6	4FSK+BW12.5KHz+TX	The equipment is set with 4FSK modulation and 12.5KHz bandwidth at maximum rated power for transmitter, powered by DC 13.60V
Op 7	4FSK+BW12.5KHz+TX	The equipment is set with 4FSK modulation and 12.5KHz bandwidth at minimum rated power for transmitter, powered by AC 120V/60Hz
Op 8	4FSK+BW12.5KHz+TX	The equipment is set with 4FSK modulation and 12.5KHz bandwidth at minimum rated power for transmitter, powered by DC 13.60V

2.4. EUT configuration

The following peripheral devices and interface cables were connected during the measurement:

- - supplied by the manufacturer
- - supplied by the lab

●	Power Cable	Length (m) :	3.00
		Shield :	Unshielded
		Detachable :	Undetachable
○	Multimeter	Manufacturer :	/
		Model No. :	/

2.5. Modifications

No modifications were implemented to meet testing criteria.

3. TEST ENVIRONMENT

3.1. Address of the test laboratory

Shenzhen Huatongwei International Inspection Co., Ltd
Keji Nan No.12 Road, Hi-tech Park, Shenzhen, China
Phone: 86-755-26715686 Fax: 86-755-26748089

The sites are constructed in conformance with the requirements of ANSI C63.7, ANSI C63.4 (2009) and CISPR Publication 22.

3.2. Test Facility

The test facility is recognized, certified, or accredited by the following organizations:

CNAS-Lab Code: L1225

Shenzhen Huatongwei International Inspection Co., Ltd. has been assessed and proved to be in compliance with CNAS-CL01 Accreditation Criteria for Testing and Calibration Laboratories (identical to ISO/IEC 17025: 2005 General Requirements) for the Competence of Testing and Calibration Laboratories, Date of Registration: Mar. 01, 2012. Valid time is until Feb. 28, 2015.

A2LA-Lab Cert. No. 2243.01

Shenzhen Huatongwei International Inspection Co., Ltd. EMC Laboratory has been accredited by A2LA for technical competence in the field of electrical testing, and proved to be in compliance with ISO/IEC 17025: 2005 General Requirements for the Competence of Testing and Calibration Laboratories and any additional program requirements in the identified field of testing. Valid time is until Sept. 30, 2015.

FCC-Registration No.: 662850

Shenzhen Huatongwei International Inspection Co., Ltd. EMC Laboratory has been registered and fully described in a report filed with the FCC (Federal Communications Commission). The acceptance letter from the FCC is maintained in our files. Registration 662850, Renewal date Jul. 01, 2009, valid time is until Jun. 30, 2015.

IC-Registration No.: 5377A

The 3m Alternate Test Site of Shenzhen Huatongwei International Inspection Co., Ltd. has been registered by Certification and Engineering Bureau of Industry Canada for the performance of radiated measurements with Registration No. 5377A on Dec. 31, 2013, valid time is until Dec. 31, 2016.

ACA

Shenzhen Huatongwei International Inspection Co., Ltd. EMC Laboratory can also perform testing for the Australian C-Tick mark as a result of our A2LA accreditation.

VCCI

The 3m Semi-anechoic chamber (12.2m×7.95m×6.7m) of Shenzhen Huatongwei International Inspection Co., Ltd. has been registered in accordance with the Regulations for Voluntary Control Measures with Registration No.:R-2484. Date of Registration: Dec. 20, 2012. Valid time is until Dec. 29, 2015.

Radiated disturbance above 1GHz measurement of Shenzhen Huatongwei International Inspection Co., Ltd. has been registered in accordance with the Regulations for Voluntary Control Measures with Registration No.: G-292. Date of Registration: Dec. 24, 2013. Valid time is until Dec. 23, 2016.

Main Ports Conducted Interference Measurement of Shenzhen Huatongwei International Inspection Co., Ltd. has been registered in accordance with the Regulations for Voluntary Control Measures with Registration No.: C-2726. Date of Registration: Dec. 20, 2012. Valid time is until Dec. 19, 2015.

Telecommunication Ports Conducted Interference Measurement of Shenzhen Huatongwei International Inspection Co., Ltd. has been registered in accordance with the Regulations for Voluntary Control Measures with Registration No.: T-1837. Date of Registration: May 07, 2013. Valid time is until May 06, 2016.

DNV

Shenzhen Huatongwei International Inspection Co., Ltd. has been found to comply with the requirements of DNV towards subcontractor of EMC and safety testing services in conjunction with the EMC and Low voltage Directives and in the voluntary field. The acceptance is based on a formal quality Audit and follow-ups according to relevant parts of ISO/IEC Guide 17025 (2005), in accordance with the requirements of the DNV Laboratory Quality Manual towards subcontractors. Valid time is until Aug. 24, 2016.

3.3. Environmental conditions

During the measurement the environmental conditions were within the listed ranges:

Temperature:	15~35°C
Relative Humidity:	30~60 %
Air Pressure:	950~1050mba

3.4. Statement of the measurement uncertainty

The data and results referenced in this document are true and accurate. The reader is cautioned that there may be errors within the calibration limits of the equipment and facilities. The measurement uncertainty was calculated for all measurements listed in this test report according to CISPR 16 - 4 „Specification for radio disturbance and immunity measuring apparatus and methods – Part 4: Uncertainty in EMC Measurements“ and is documented in the Shenzhen Huatongwei International Inspection Co., Ltd quality system according to DIN EN ISO/IEC 17025. Furthermore, component and process variability of devices similar to that tested may result in additional deviation. The manufacturer has the sole responsibility of continued compliance of the device.

Hereafter the best measurement capability for Shenzhen Huatongwei laboratory is reported:

Test Items	Measurement Uncertainty	Notes
Frequency stability	25 Hz	(1)
Transmitter power conducted	0.57 dB	(1)
Transmitter power Radiated	2.20 dB	(1)
Conducted spurious emission 9KHz-40 GHz	1.60 dB	(1)
Conducted Emission 9KHz-30MHz	3.39 dB	(1)
Radiated Emission 30~1000MHz	4.65 dB	(1)
Radiated Emission 1~18GHz	5.16 dB	(1)
Radiated Emission 18-40GHz	5.54 dB	(1)
Occupied Bandwidth	-----	(1)
Emission Mask	-----	(1)
Modulation Characteristic	-----	(1)
Transmitter Frequency Behavior	-----	(1)

- (1) This uncertainty represents an expanded uncertainty expressed at approximately the 95% confidence level using a coverage factor of $k=1.96$.

3.5. Equipments Used during the Test

AC Power Conducted Emission				
Name of Equipment	Manufacturer	Model	Serial Number	Calibration Due
Artificial Mains	Rohde&Schwarz	ESH2-Z5	100028	10/26/2014
EMI Test Receiver	Rohde&Schwarz	ESCS 30	100038	10/26/2014
Pulse Limiter	Rohde&Schwarz	ESHSZ2	100044	10/26/2014
EMI Test Software	Rohde&Schwarz	ES-K1 V1.71	N/A	N/A
RF COMMUNICATION TEST SET	HP	8920A	3813A10206	10/26/2014

DC Power Conducted Emission				
Name of Equipment	Manufacturer	Model	Serial Number	Calibration Due
Artificial Mains	Rohde&Schwarz	ESH2-Z6	100210	10/26/2014
Artificial Mains	Rohde&Schwarz	ESH2-Z6	100211	10/26/2014
EMI Test Receiver	Rohde&Schwarz	ESCS 30	100038	10/26/2014
Pulse Limiter	Rohde&Schwarz	ESHSZ2	100044	10/26/2014
EMI Test Software	Rohde&Schwarz	ES-K1 V1.71	N/A	N/A
RF COMMUNICATION TEST SET	HP	8920A	3813A10206	10/26/2014

Modulation Characteristic				
Name of Equipment	Manufacturer	Model	Serial Number	Calibration Due
RF COMMUNICATION TEST SET	HP	8920A	3813A10206	10/26/2014

Frequency Stability				
Name of Equipment	Manufacturer	Model	Serial Number	Calibration Due
RF COMMUNICATION TEST SET	HP	8920A	3813A10206	10/26/2014
Signal Generator	Rohde&Schwarz	SMT03	100059	10/26/2014
Climate Chamber	ESPEC	EL-10KA	05107008	10/26/2014

Transmitter Radiated Spurious Emssion				
Name of Equipment	Manufacturer	Model	Serial Number	Calibration Due
Ultra-Broadband Antenna	Rohde&Schwarz	HL562	100015	10/26/2014
EMI Test Receiver	Rohde&Schwarz	ESI 26	100009	10/26/2014
RF Test Panel	Rohde&Schwarz	TS / RSP	335015/ 0017	N/A
HORN ANTENNA	Rohde&Schwarz	HF906	100039	10/26/2014
Turntable	ETS	2088	2149	N/A
Antenna Mast	ETS	2075	2346	N/A
EMI Test Software	Rohde&Schwarz	ES-K1 V1.71	N/A	N/A
RF COMMUNICATION TEST SET	HP	8920A	3813A10206	10/26/2014
Ultra-Broadband Antenna	ShwarzBeck	VULB9163	538	10/26/2014
Ultra-Broadband Antenna	ShwarzBeck	VULB9163	539	10/26/2014
HORN ANTENNA	ShwarzBeck	9120D	1012	10/26/2014
HORN ANTENNA	ShwarzBeck	9120D	1011	10/26/2014
TURNTABLE	MATURO	TT2.0	----	N/A
ANTENNA MAST	MATURO	TAM-4.0-P	----	N/A

Maximum Transmitter Power & Spurious Emssion On Antenna Port & Occupied Bandwidth & Emission Mask				
Name of Equipment	Manufacturer	Model	Serial Number	Calibration Due
Receiver	Rohde&Schwarz	ESI 26	100009	10/26/2014
Attenuator	R&S	ESH3-22	100449	10/26/2014
RF COMMUNICATION TEST SET	HP	8920A	3813A10206	10/26/2014
High-Pass Filter	Anritsu	MP526B	6220875256	10/26/2014
High-Pass Filter	Anritsu	MP526D	6220878392	10/26/2014
Spectrum Analyzyer	Aglient	E4407B	MY44210775	10/26/2014
Spectrum Analyzyer	Rohde&Schwarz	FSP40	1164.4391.40	10/26/2014

Transient Frequency Behavior				
Name of Equipment	Manufacturer	Model	Serial Number	Calibration Due
Signal Generator	Rohde&Schwarz	SMT03	100059	10/26/2014
Storage Oscilloscope	Tektronix	TDS3054B	B033027	10/26/2014
RF COMMUNICATION TEST SET	HP	8920A	3813A10206	10/26/2014

The calibration interval was one year.

4. TEST CONDITIONS AND RESULTS

4.1. Conducted Emissions Test

TEST APPLICABLE

The EUT was tested according to ANSI C63.4 - 2009. The frequency spectrum from 0.15 MHz to 30 MHz was investigated. The LISN used was 50 ohm / 50 u Henry as specified by section 5.1 of ANSI C63.4 - 2009. Cables and peripherals were moved to find the maximum emission levels for each frequency.

TEST CONFIGURATION

For AC Power

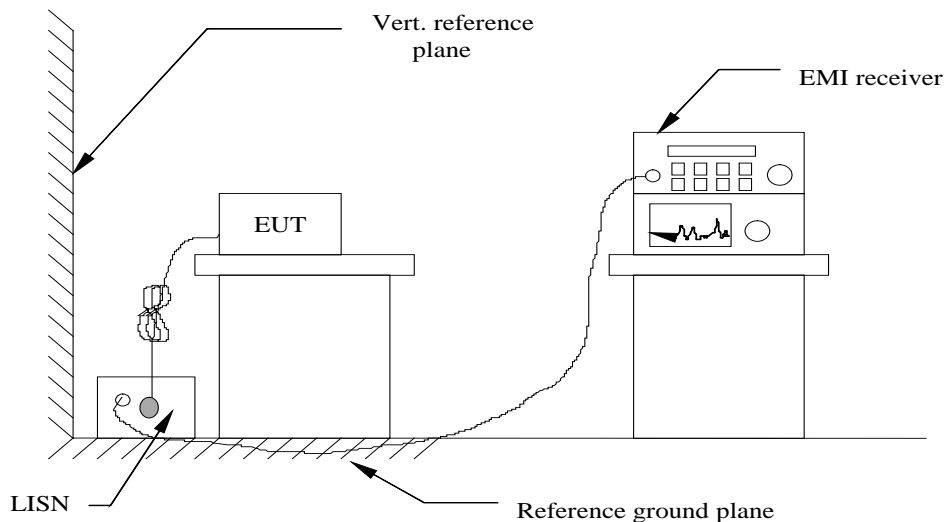

For DC Power

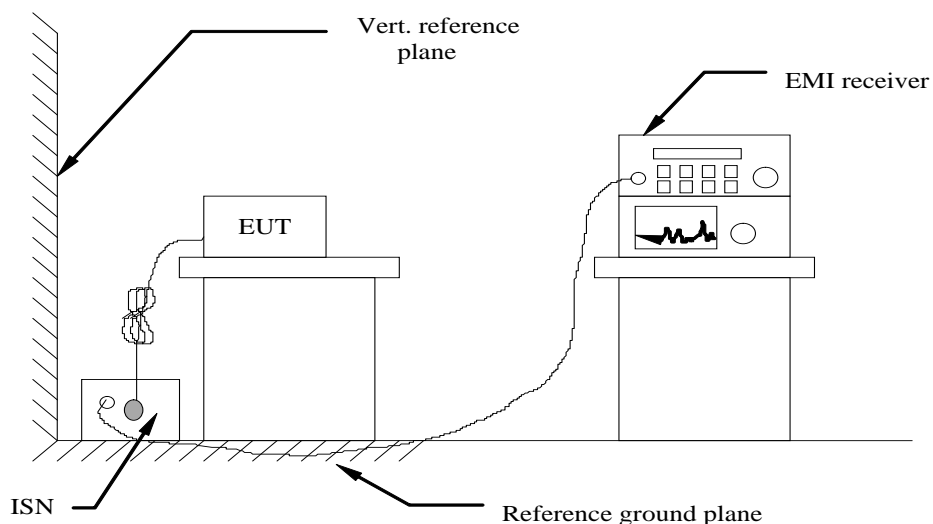

TEST PROCEDURE

- 1 The equipment was set up as per the test configuration to simulate typical actual usage per the user's manual. The EUT is a tabletop system; a wooden table with a height of 0.8 meters is used and is placed on the ground plane as per ANSI C63.4-2009.
- 2 Support equipment, if needed, was placed as per ANSI C63.4-2009.
- 3 All I/O cables were positioned to simulate typical actual usage as per ANSI C63.4-2009.

- 4 If a EUT received AC120V/60Hz power through a Line Impedance Stabilization Network (LISN) which supplied power source and was grounded to the ground plane.
- 5 If a EUT received DC 13.60V power through a Impedance Stabilization Network (ISN) which supplied power source and was grounded to the ground plane.
- 6 All support equipments received AC power from a second LISN, if any.
- 7 The EUT test program was started. Emissions were measured on each current carrying line of the EUT using a spectrum Analyzer / Receiver connected to the LISN powering the EUT. The LISN has two monitoring points: Line 1 (Hot Side) and Line 2 (Neutral Side). Two scans were taken: one with Line 1 connected to Analyzer / Receiver and Line 2 connected to a 50 ohm load; the second scan had Line 1 connected to a 50 ohm load and Line 2 connected to the Analyzer / Receiver.
- 8 Analyzer / Receiver scanned from 150 KHz to 30MHz for emissions in each of the test modes.
- 9 During the above scans, the emissions were maximized by cable manipulation.

Conducted Power Line Emission Limit

For intentional device, according to § 15.207(a) for AC Power Conducted Emission Limits is as following:

Frequency (MHz)	Maximum RF Line Voltage (dBµV)			
	CLASS A		CLASS B	
	Q.P.	Ave.	Q.P.	Ave.
0.15 - 0.50	79	66	66-56*	56-46*
0.50 - 5.00	73	60	56	46
5.00 - 30.0	73	60	60	50

* Decreasing linearly with the logarithm of the frequency

TEST RESULTS

Remark: we tested all Op 1 to Op 8, recorded worst case at Op 1, Op 2, Op 5 and Op 6.

Test mode:	OP 1	Polarization	L
------------	------	--------------	---

SCAN TABLE: "Voltage (9K-30M) FIN"

Short Description: 150K-30M Voltage

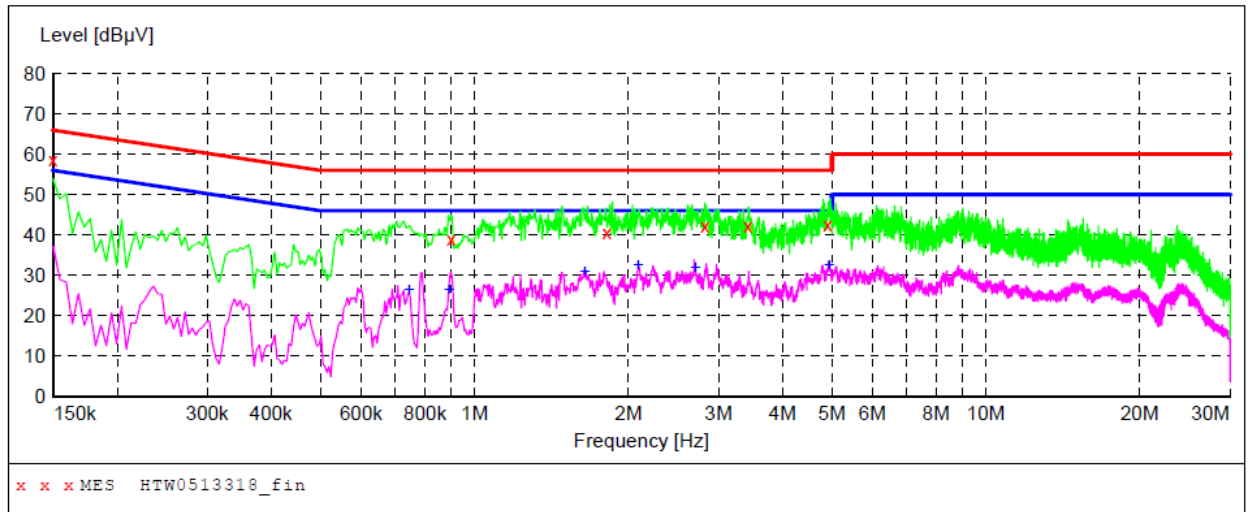

MEASUREMENT RESULT: "HTW0513318_fin"

5/13/2014 9:54AM

Frequency MHz	Level dBµV	Transd dB	Limit dBµV	Margin dB	Detector	Line	PE
0.150000	58.80	10.3	66	7.2	QP	L1	GND
0.901500	39.20	10.2	56	16.8	QP	L1	GND
1.815000	40.70	10.3	56	15.3	QP	L1	GND
2.823000	42.20	10.3	56	13.8	QP	L1	GND
3.430500	42.20	10.3	56	13.8	QP	L1	GND
4.911000	42.50	10.3	56	13.5	QP	L1	GND

MEASUREMENT RESULT: "HTW0513318_fin2"

5/13/2014 9:54AM

Frequency MHz	Level dBµV	Transd dB	Limit dBµV	Margin dB	Detector	Line	PE
0.744000	26.40	10.2	46	19.6	AV	L1	GND
0.892500	26.60	10.2	46	19.4	AV	L1	GND
1.644000	30.80	10.3	46	15.2	AV	L1	GND
2.089500	32.60	10.3	46	13.4	AV	L1	GND
2.701500	31.80	10.3	46	14.2	AV	L1	GND
4.929000	32.70	10.3	46	13.3	AV	L1	GND

Test mode:	OP 1	Polarization	N
------------	------	--------------	---

SCAN TABLE: "Voltage (9K-30M)FIN"

Short Description: 150K-30M Voltage

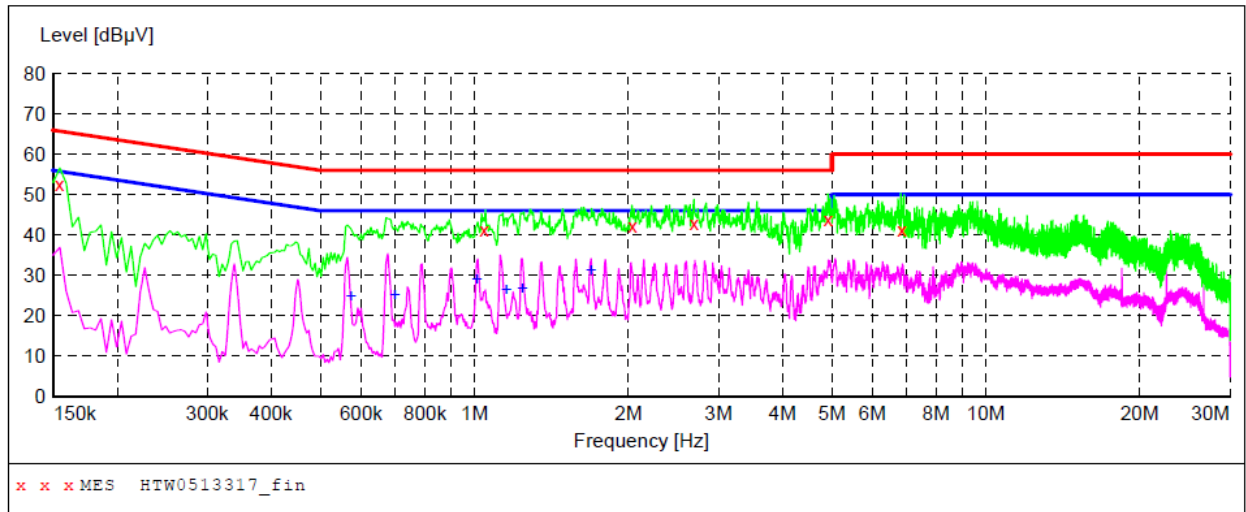

MEASUREMENT RESULT: "HTW0513317_fin"

5/13/2014 9:51AM

Frequency MHz	Level dBµV	Transd dB	Limit dBµV	Margin dB	Detector	Line	PE
0.154500	52.40	10.3	66	13.4	QP	N	GND
1.045500	41.20	10.3	56	14.8	QP	N	GND
2.035500	42.30	10.3	56	13.7	QP	N	GND
2.688000	42.90	10.3	56	13.1	QP	N	GND
4.915500	43.80	10.3	56	12.2	QP	N	GND
6.850500	41.20	10.4	60	18.8	QP	N	GND

MEASUREMENT RESULT: "HTW0513317_fin2"

5/13/2014 9:51AM

Frequency MHz	Level dBµV	Transd dB	Limit dBµV	Margin dB	Detector	Line	PE
0.573000	24.90	10.3	46	21.1	AV	N	GND
0.699000	25.30	10.3	46	20.7	AV	N	GND
1.009500	29.10	10.3	46	16.9	AV	N	GND
1.153500	26.40	10.3	46	19.6	AV	N	GND
1.239000	26.80	10.3	46	19.2	AV	N	GND
1.689000	31.20	10.3	46	14.8	AV	N	GND

Test mode:	OP 2	Polarization	+
------------	------	--------------	---

SCAN TABLE: "Voltage (9K-30M)FIN"

Short Description: 150K-30M Voltage

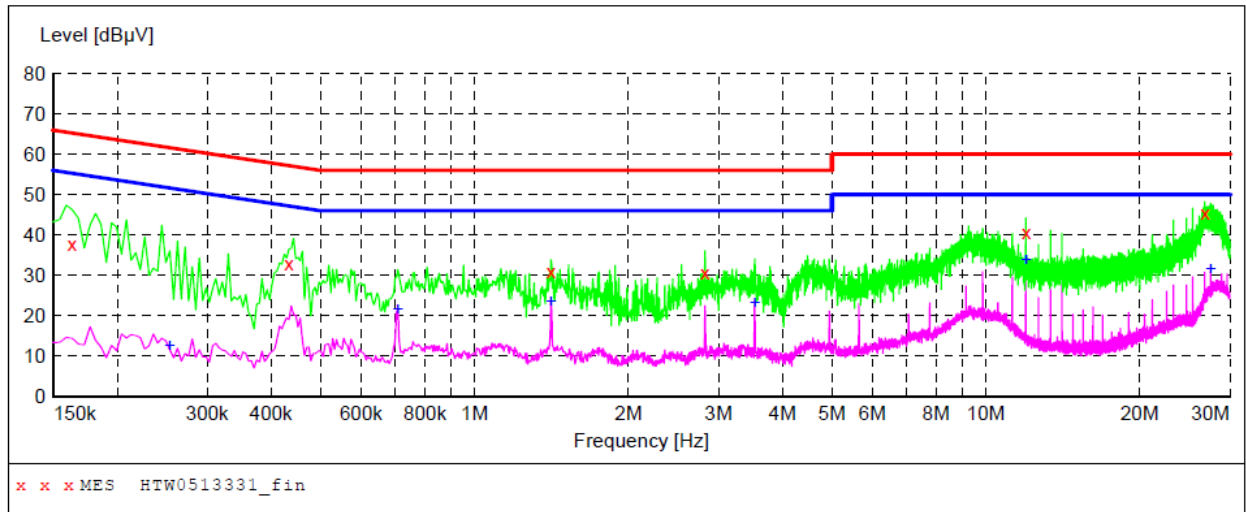

MEASUREMENT RESULT: "HTW0513331_fin"

5/13/2014 4:13PM

Frequency MHz	Level dBµV	Transd dB	Limit dBµV	Margin dB	Detector	Line	PE
0.163500	37.90	10.3	65	27.4	QP	+	GND
0.433500	33.00	10.4	57	24.2	QP	+	GND
1.410000	30.90	10.3	56	25.1	QP	+	GND
2.823000	30.60	10.3	56	25.4	QP	+	GND
11.994000	40.50	10.6	60	19.5	QP	+	GND
26.812500	45.30	11.0	60	14.7	QP	+	GND

MEASUREMENT RESULT: "HTW0513331_fin2"

5/13/2014 4:13PM

Frequency MHz	Level dBµV	Transd dB	Limit dBµV	Margin dB	Detector	Line	PE
0.253500	12.70	10.5	52	38.9	AV	+	GND
0.708000	21.60	10.3	46	24.4	AV	+	GND
1.410000	23.50	10.3	46	22.5	AV	+	GND
3.529500	23.30	10.3	46	22.7	AV	+	GND
11.994000	33.90	10.6	50	16.1	AV	+	GND
27.519000	31.60	11.0	50	18.4	AV	+	GND

Test mode:	OP 2	Polarization	-
------------	------	--------------	---

SCAN TABLE: "Voltage (9K-30M)FIN"

Short Description: 150K-30M Voltage

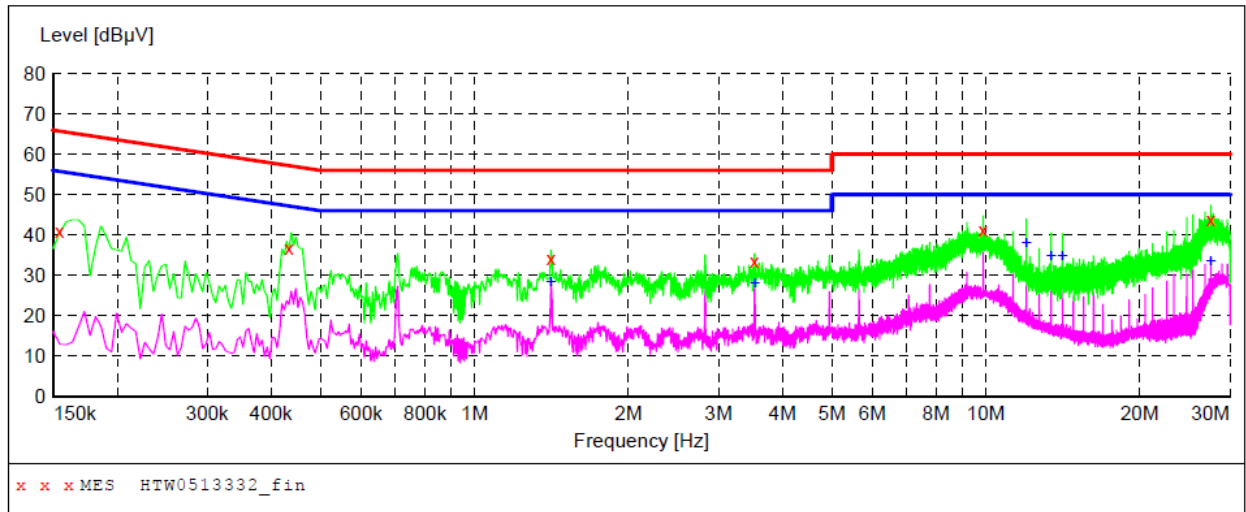

MEASUREMENT RESULT: "HTW0513332_fin"

5/13/2014 4:16PM

Frequency MHz	Level dBµV	Transd dB	Limit dBµV	Margin dB	Detector	Line	PE
0.154500	40.90	10.3	66	24.9	QP	-	GND
0.433500	36.60	10.4	57	20.6	QP	-	GND
1.410000	34.20	10.3	56	21.8	QP	-	GND
3.529500	33.40	10.3	56	22.6	QP	-	GND
9.879000	41.40	10.6	60	18.6	QP	-	GND
27.519000	43.90	11.0	60	16.1	QP	-	GND

MEASUREMENT RESULT: "HTW0513332_fin2"

5/13/2014 4:16PM

Frequency MHz	Level dBµV	Transd dB	Limit dBµV	Margin dB	Detector	Line	PE
1.410000	28.30	10.3	46	17.7	AV	-	GND
3.529500	28.00	10.3	46	18.0	AV	-	GND
11.994000	38.00	10.6	50	12.0	AV	-	GND
13.407000	34.90	10.7	50	15.1	AV	-	GND
14.113500	34.70	10.7	50	15.3	AV	-	GND
27.519000	33.70	11.0	50	16.3	AV	-	GND

Test mode:	OP 5	Polarization	L
------------	------	--------------	---

SCAN TABLE: "Voltage (9K-30M) FIN"

Short Description: 150K-30M Voltage

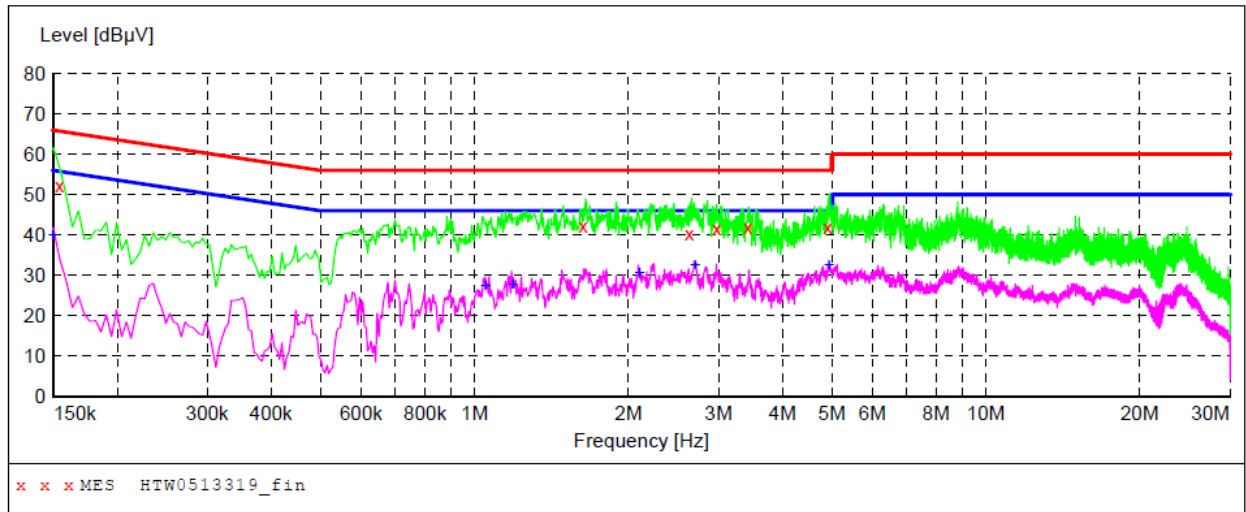

MEASUREMENT RESULT: "HTW0513319_fin"

5/13/2014 9:57AM

Frequency MHz	Level dBµV	Transd dB	Limit dBµV	Margin dB	Detector	Line	PE
0.154500	52.20	10.3	66	13.6	QP	L1	GND
1.630500	42.30	10.3	56	13.7	QP	L1	GND
2.629500	40.30	10.3	56	15.7	QP	L1	GND
2.976000	41.70	10.3	56	14.3	QP	L1	GND
3.426000	41.90	10.3	56	14.1	QP	L1	GND
4.906500	42.00	10.3	56	14.0	QP	L1	GND

MEASUREMENT RESULT: "HTW0513319_fin2"

5/13/2014 9:57AM

Frequency MHz	Level dBµV	Transd dB	Limit dBµV	Margin dB	Detector	Line	PE
0.150000	40.10	10.3	56	15.9	AV	L1	GND
1.050000	27.30	10.3	46	18.7	AV	L1	GND
1.189500	27.60	10.3	46	18.4	AV	L1	GND
2.098500	30.60	10.3	46	15.4	AV	L1	GND
2.697000	32.70	10.3	46	13.3	AV	L1	GND
4.938000	32.50	10.3	46	13.5	AV	L1	GND

Test mode:	OP 5	Polarization	N
------------	------	--------------	---

SCAN TABLE: "Voltage (9K-30M)FIN"

Short Description: 150K-30M Voltage

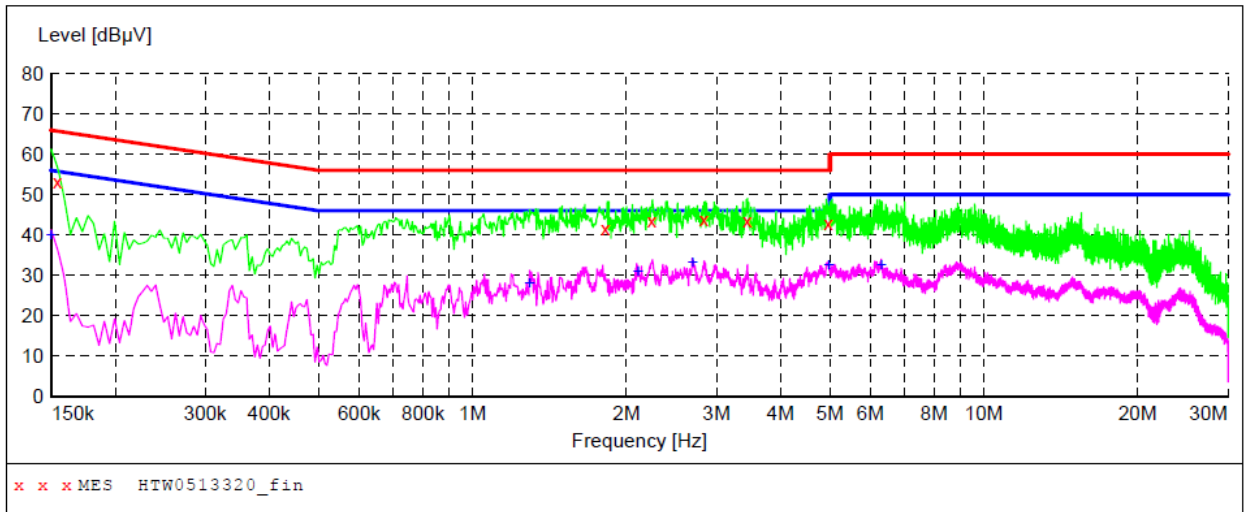

MEASUREMENT RESULT: "HTW0513320_fin"

5/13/2014 10:00AM

Frequency MHz	Level dBµV	Transd dB	Limit dBµV	Margin dB	Detector	Line	PE
0.154500	53.30	10.3	66	12.5	QP	N	GND
1.819500	41.70	10.3	56	14.3	QP	N	GND
2.242500	43.60	10.3	56	12.4	QP	N	GND
2.832000	43.80	10.3	56	12.2	QP	N	GND
3.448500	43.50	10.3	56	12.5	QP	N	GND
4.965000	42.90	10.3	56	13.1	QP	N	GND

MEASUREMENT RESULT: "HTW0513320_fin2"

5/13/2014 10:00AM

Frequency MHz	Level dBµV	Transd dB	Limit dBµV	Margin dB	Detector	Line	PE
0.150000	40.10	10.3	56	15.9	AV	N	GND
1.293000	27.90	10.3	46	18.1	AV	N	GND
2.107500	31.10	10.3	46	14.9	AV	N	GND
2.692500	33.10	10.3	46	12.9	AV	N	GND
4.969500	32.50	10.3	46	13.5	AV	N	GND
6.297000	32.50	10.4	50	17.5	AV	N	GND

Test mode:	OP 6	Polarization	+
------------	------	--------------	---

SCAN TABLE: "Voltage (9K-30M) FIN"

Short Description: 150K-30M Voltage

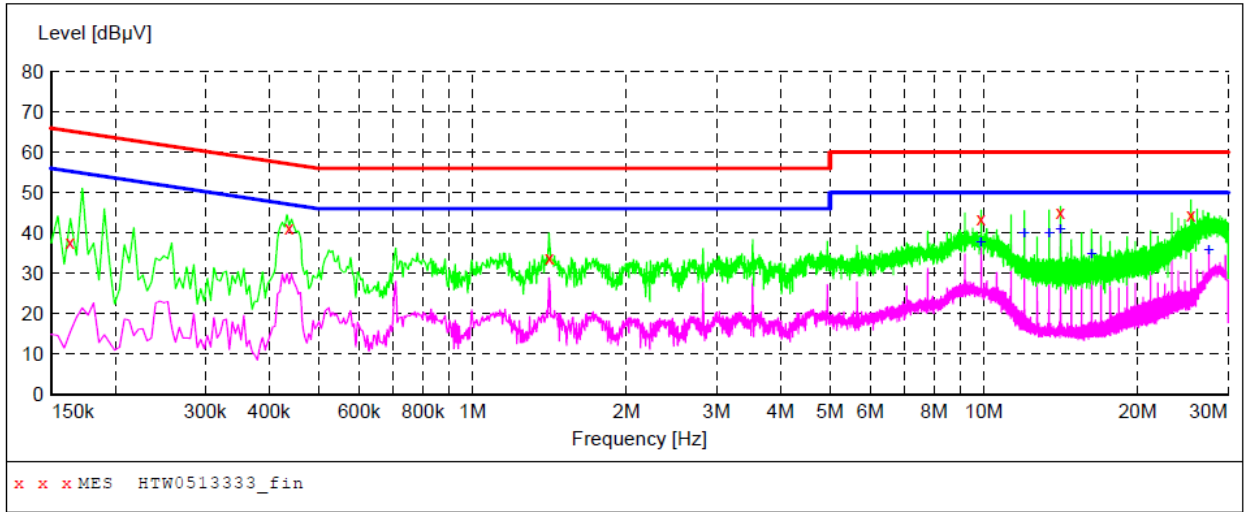

MEASUREMENT RESULT: "HTW0513333_fin"

5/13/2014 4:21PM

Frequency MHz	Level dBµV	Transd dB	Limit dBµV	Margin dB	Detector	Line	PE
0.163500	37.90	10.3	65	27.4	QP	+	GND
0.438000	41.20	10.4	57	15.9	QP	+	GND
1.414500	34.00	10.3	56	22.0	QP	+	GND
9.879000	43.40	10.6	60	16.6	QP	+	GND
14.113500	45.10	10.7	60	14.9	QP	+	GND
25.404000	44.50	11.0	60	15.5	QP	+	GND

MEASUREMENT RESULT: "HTW0513333_fin2"

5/13/2014 4:21PM

Frequency MHz	Level dBµV	Transd dB	Limit dBµV	Margin dB	Detector	Line	PE
9.879000	37.90	10.6	50	12.1	AV	+	GND
11.994000	39.90	10.6	50	10.1	AV	+	GND
13.407000	39.90	10.7	50	10.1	AV	+	GND
14.113500	40.80	10.7	50	9.2	AV	+	GND
16.228500	34.70	10.7	50	15.3	AV	+	GND
27.519000	35.80	11.0	50	14.2	AV	+	GND

Test mode:	OP 6	Polarization	-
------------	------	--------------	---

SCAN TABLE: "Voltage (9K-30M)FIN"

Short Description: 150K-30M Voltage

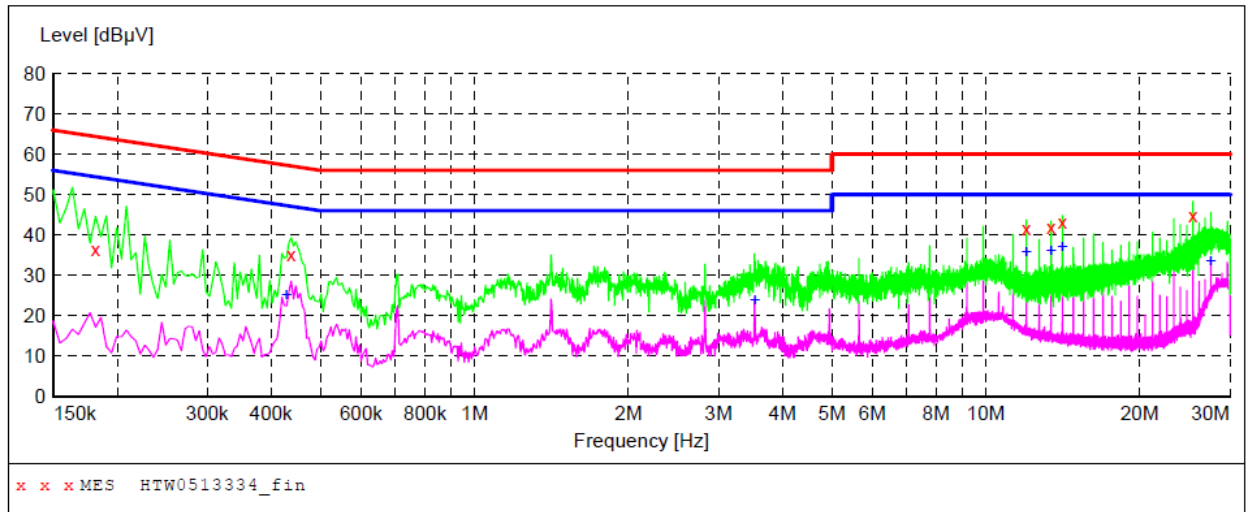

MEASUREMENT RESULT: "HTW0513334_fin"

5/13/2014 4:23PM

Frequency MHz	Level dBµV	Transd dB	Limit dBµV	Margin dB	Detector	Line	PE
0.181500	36.40	10.4	64	28.0	QP	-	GND
0.438000	35.30	10.4	57	21.8	QP	-	GND
11.994000	41.60	10.6	60	18.4	QP	-	GND
13.407000	42.00	10.7	60	18.0	QP	-	GND
14.113500	43.10	10.7	60	16.9	QP	-	GND
25.404000	44.70	11.0	60	15.3	QP	-	GND

MEASUREMENT RESULT: "HTW0513334_fin2"

5/13/2014 4:23PM

Frequency MHz	Level dBµV	Transd dB	Limit dBµV	Margin dB	Detector	Line	PE
0.429000	25.20	10.4	47	22.1	AV	-	GND
3.529500	24.00	10.3	46	22.0	AV	-	GND
11.994000	35.90	10.6	50	14.1	AV	-	GND
13.407000	36.00	10.7	50	14.0	AV	-	GND
14.113500	37.00	10.7	50	13.0	AV	-	GND
27.519000	33.50	11.0	50	16.5	AV	-	GND

4.2. Occupied Bandwidth and Emission Mask Test

TEST APPLICABLE

- (a). Occupied Bandwidth: The EUT was connected to the audio signal generator and the spectrum analyzer via the main RF connector, and through an appropriate attenuator. The EUT was controlled to transmit its maximum power. Then the bandwidth of 99% power can be measured by the spectrum analyzer.
- (b). Emission Mask B: For transmitters that are equipped with an audio low-pass filter pursuant to §90.211(a), the power of any emission must be below the unmodulated carrier power (P) as follows:
- (1) On any frequency removed from the assigned frequency by more than 50 percent, but not more than 100 percent of the authorized bandwidth: At least 25 dB.
 - (2) On any frequency removed from the assigned frequency by more than 100 percent, but not more than 250 percent of the authorized bandwidth: At least 35 dB.
 - (3) On any frequency removed from the assigned frequency by more than 250 percent of the authorized bandwidth: At least $43 + 10 \log (P)$ dB.
- (c). Emission Mask D, 12.5 kHz channel bandwidth equipment: For transmitters designed to operate with a 12.5 kHz channel bandwidth, any emission must be attenuated below the power (P) of the highest emission contained within the authorized bandwidth as follows:
- (1) On any frequency from the center of the authorized bandwidth f_0 to 5.625 kHz removed from f_0 : Zero dB.
 - (2) On any frequency removed from the center of the authorized bandwidth by a displacement frequency (f_d in kHz) of more than 5.625 kHz but no more than 12.5 kHz: At least $7.27(f_d - 2.88 \text{ kHz})$ dB.
 - (3) On any frequency removed from the center of the authorized bandwidth by a displacement frequency (f_d in kHz) of more than 12.5 kHz: At least $50 + 10 \log (P)$ dB or 70 dB, whichever is the lesser attenuation.

TEST CONFIGURATION

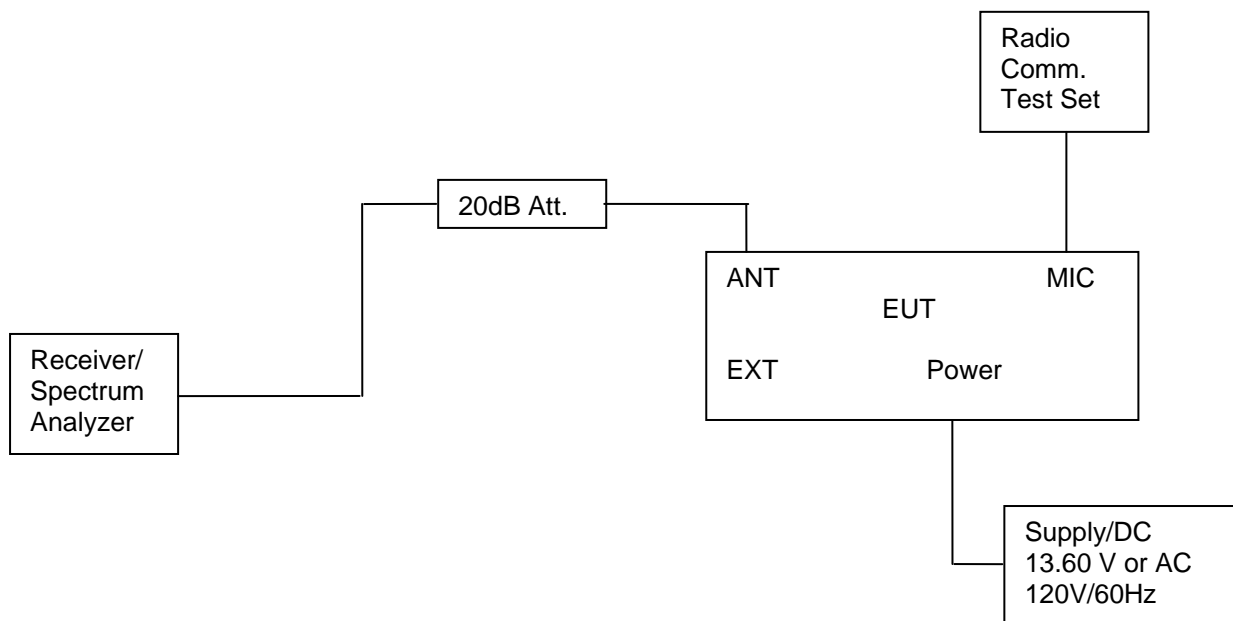

TEST PROCEDURE

- 1 The EUT was placed on a turn table which is 0.8m above ground plane.
- 2 The EUT was modulated by 2.5 KHz Sine wave audio signal; the level of the audio signal employed is 16 dB greater than that necessary to produce 50% of rated system deviation. Rated system deviation is 2.5 kHz (12.5 kHz channel spacing) and 5 kHz (25 kHz channel spacing).
- 3 Set EUT as normal operation.
- 4 Set SPA Center Frequency = fundamental frequency, RBW=300Hz, VBW= 3 KHz, span =50 KHz.
- 5 Set SPA Max hold. Mark peak, Set 99% Occupied Bandwidth and 26dB Occupied Bandwidth.
- 6 Set SPA Center Frequency=fundamental frequency, set =300Hz, VBW=1 KHz, span=50 KHz for 12.5 channel spacing.

TEST RESULTS

Remark: We tested Op 1 to Op 8, recorded worst case at Op 1, Op 2, Op 5 and Op 6.

4.2.1 Occupied Bandwidth

Modulation Type	Operation Mode	Test Channel	Operation frequency (MHz)	Occupied Bandwidth (KHz)		Limit (KHz)	Result
				99%	26dB		
Analog/FM	Op 1	Lowest CH	450.5	9.70	10.50	12.5	Pass
		Middle CH	488.5	9.70	10.50		
		Highest CH	526.5	9.50	10.50		
	Op 2	Lowest CH	450.5	9.70	10.50	12.5	Pass
		Middle CH	488.5	9.70	10.50		
		Highest CH	526.5	9.50	10.50		
Digital/4FSK	Op 5	Lowest CH	450.5	7.70	10.20	12.5	Pass
		Middle CH	488.5	7.90	10.60		
		Highest CH	526.5	7.70	9.50		
	Op 6	Lowest CH	450.5	7.90	10.20	12.5	Pass
		Middle CH	488.5	7.80	9.70		
		Highest CH	526.5	7.80	10.10		

Test plot as follows:

Modulation Type

FM

Operation Mode

Op 1

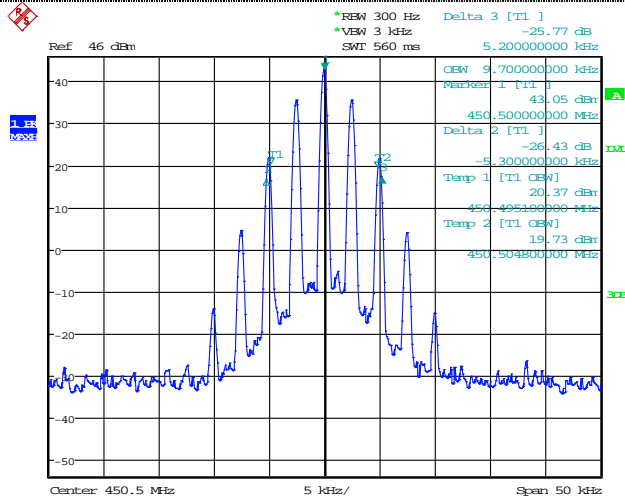

Date: 23.MAY.2014 20:54:52

Lowest CH

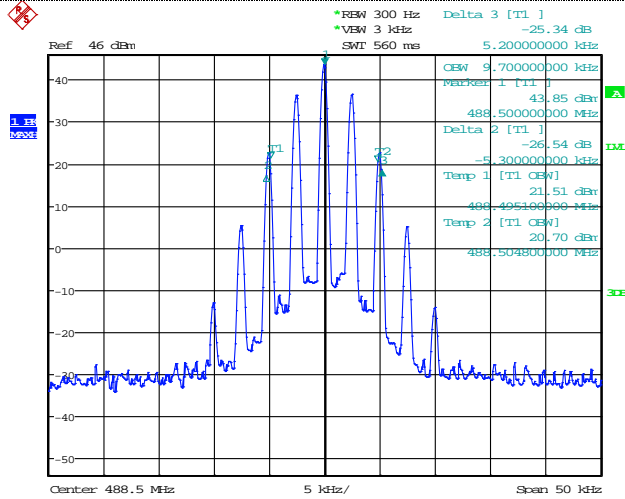

Date: 29.MAY.2014 10:13:20

Middle CH

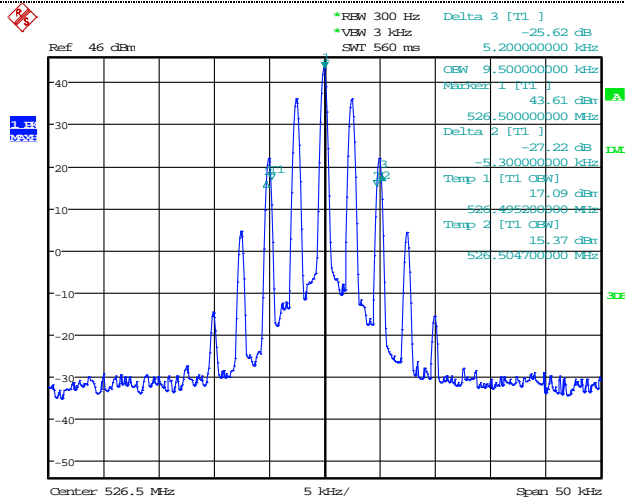

Date: 29.MAY.2014 10:14:47

Highest CH

Modulation Type

FM

Operation Mode

Op 2

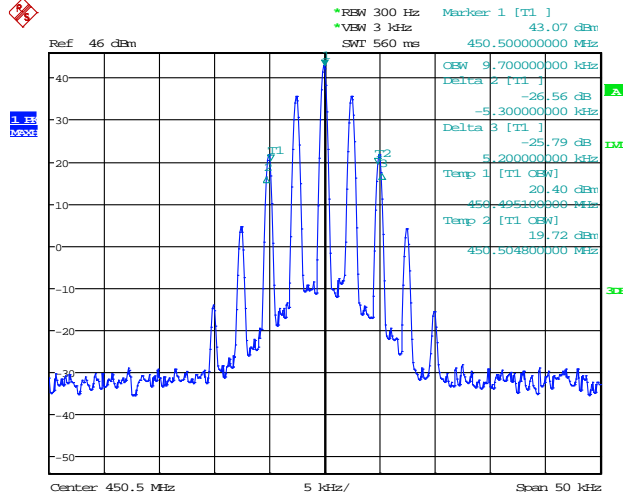

Date: 23.MAY.2014 20:55:24

Lowest CH

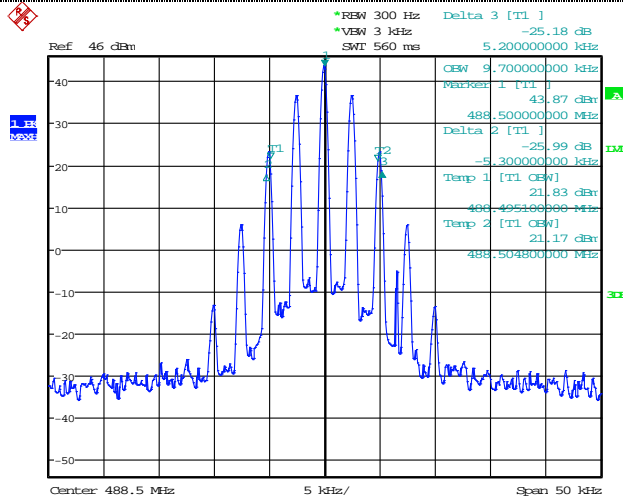

Date: 29.MAY.2014 11:02:37

Middle CH

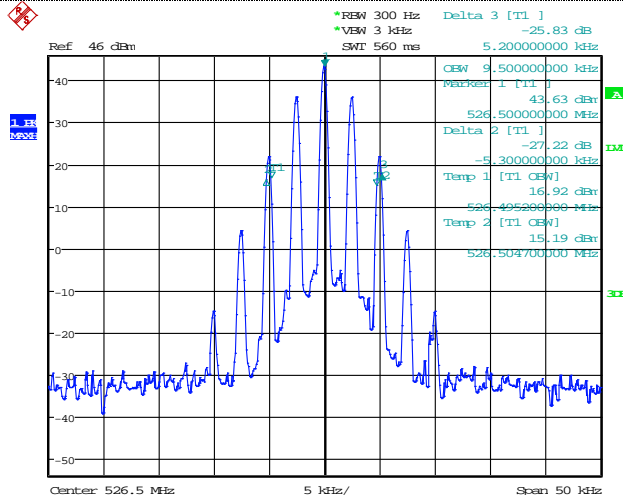

Date: 29.MAY.2014 11:06:16

Highest CH

Modulation Type

4FSK

Operation Mode

Op 5

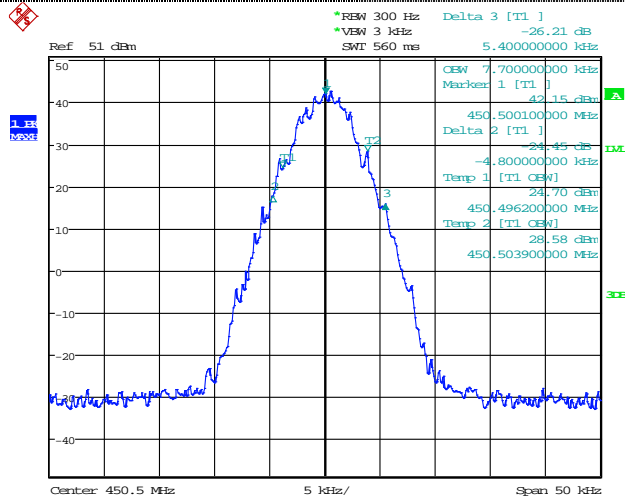

Date: 23.MAY.2014 20:05:13

Lowest CH

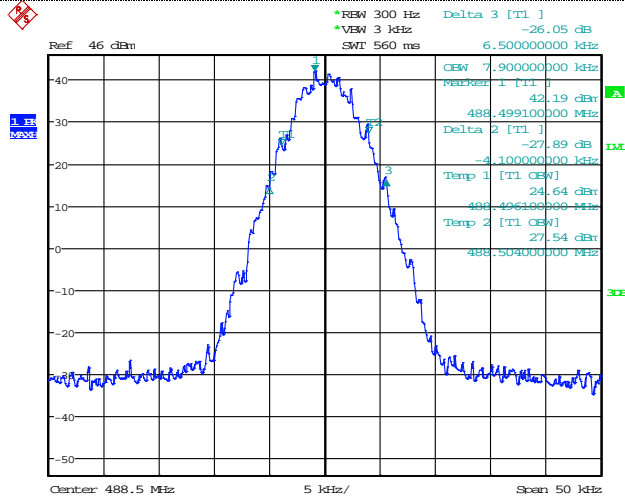

Date: 29.MAY.2014 10:45:49

Middle CH

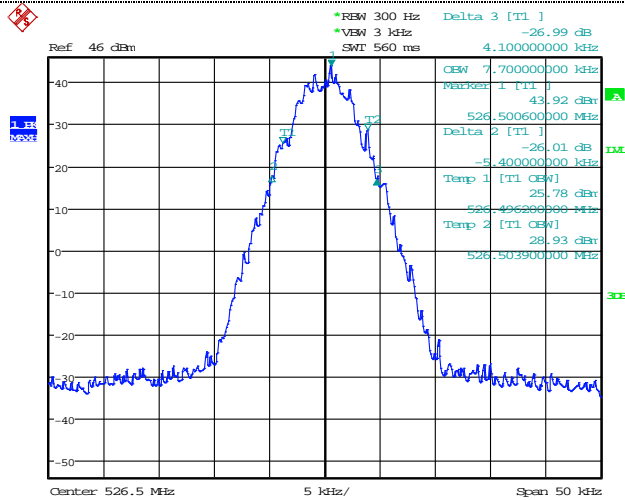

Date: 29.MAY.2014 10:51:59

Highest CH

Modulation Type

4FSK

Operation Mode

Op 6

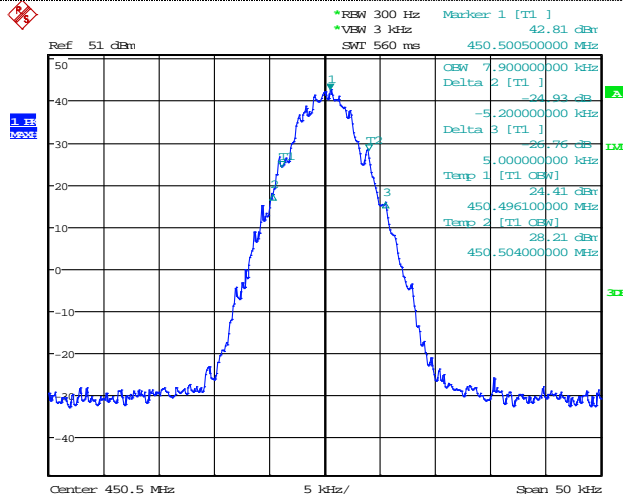

Date: 23.MAY.2014 20:05:41

Lowest CH

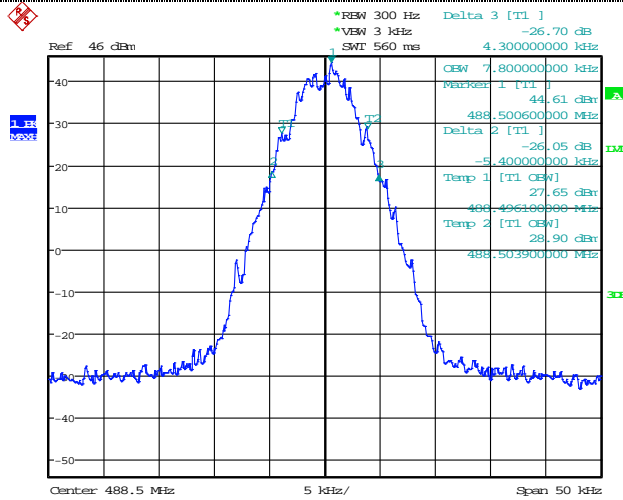

Date: 29.MAY.2014 10:59:43

Middle CH

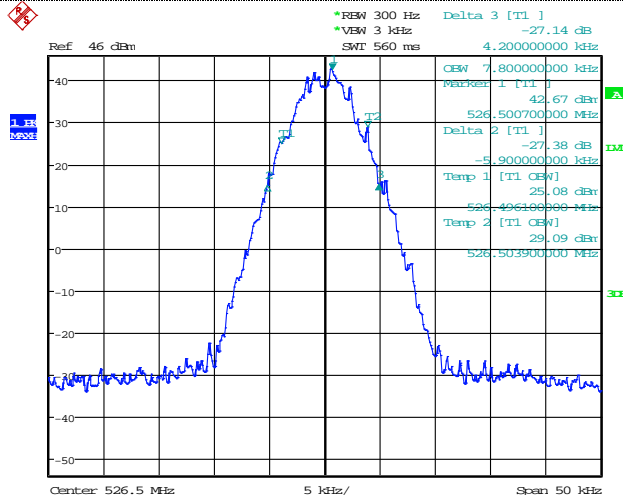

Date: 29.MAY.2014 10:53:14

Highest CH

4.2.2 Emission Mask

Modulation Type	Channel Sparation	Operation Mode	Test Channel	Test Frequency (MHz)	Applicable Mask	RBW (Hz)
Analog/FM	12.5 KHz	Op 1	Lowest CH	450.5	D	300
			Middle CH	488.5	D	300
			Highest CH	526.5	D	300
		Op 2	Lowest CH	450.5	D	300
			Middle CH	488.5	D	300
			Highest CH	526.5	D	300
Digital/4FSK	12.5 KHz	Op 5	Lowest CH	450.5	D	300
			Middle CH	488.5	D	300
			Highest CH	526.5	D	300
		Op 6	Lowest CH	450.5	D	300
			Middle CH	488.5	D	300
			Highest CH	526.5	D	300

Test plot as follows:

Note: The Black curve represents unmodulated signal.
The Blue curve represents modulated signal.

Modulation Type

FM

Operation Mode

Op 1

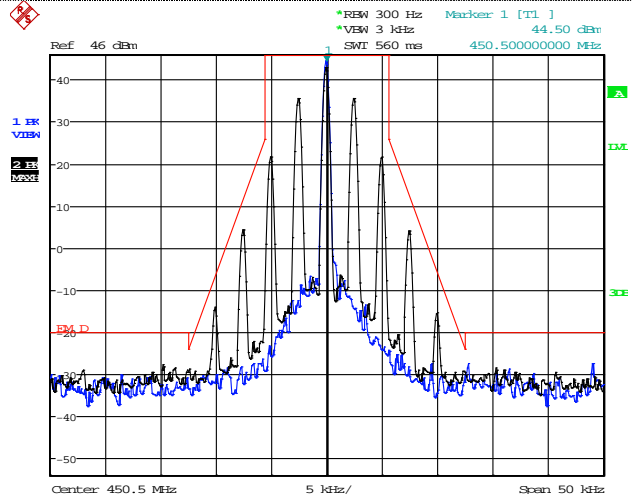

Date: 23.MAY.2014 20:57:45

Lowest CH

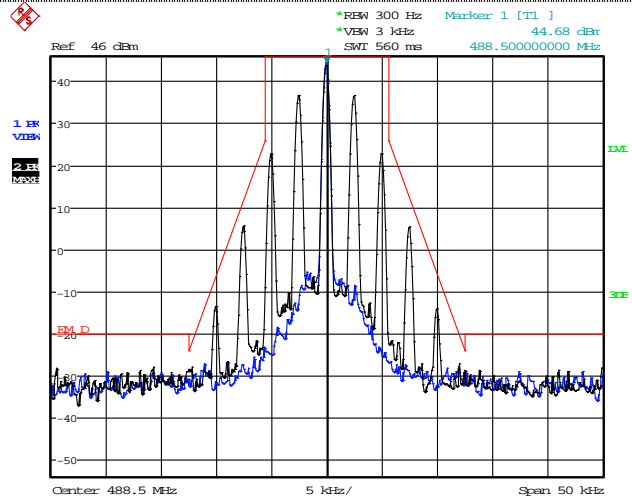

Date: 29.MAY.2014 10:12:36

Middle CH

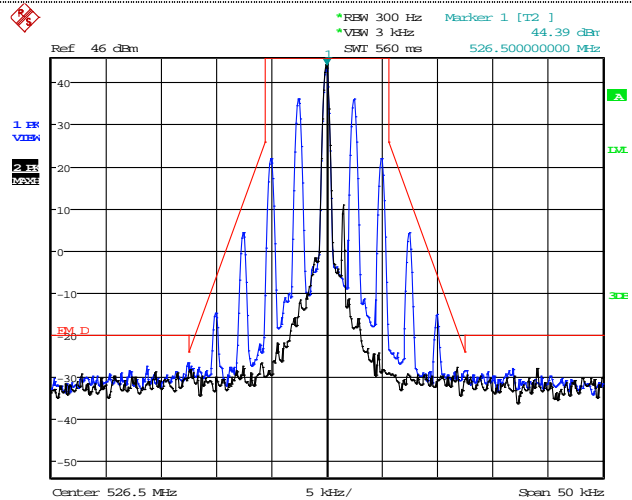

Date: 29.MAY.2014 10:16:49

Highest CH

Modulation Type

FM

Operation Mode

Op 2

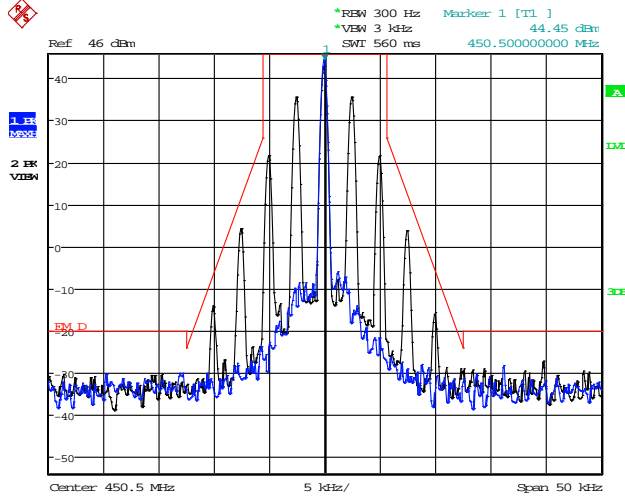

Date: 23.MAY.2014 20:58:13

Lowest CH

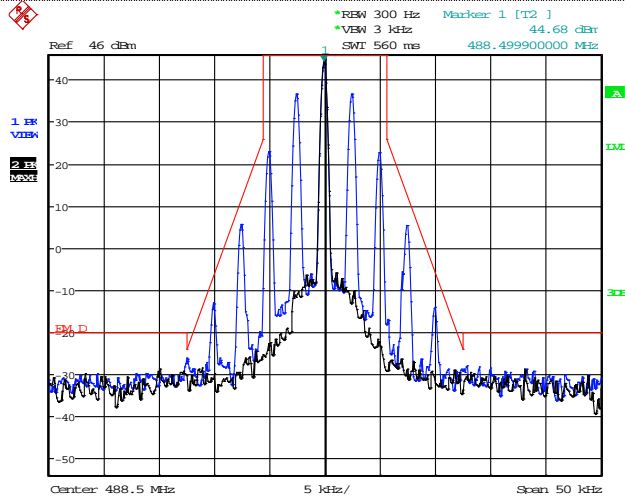

Date: 29.MAY.2014 11:04:13

Middle CH

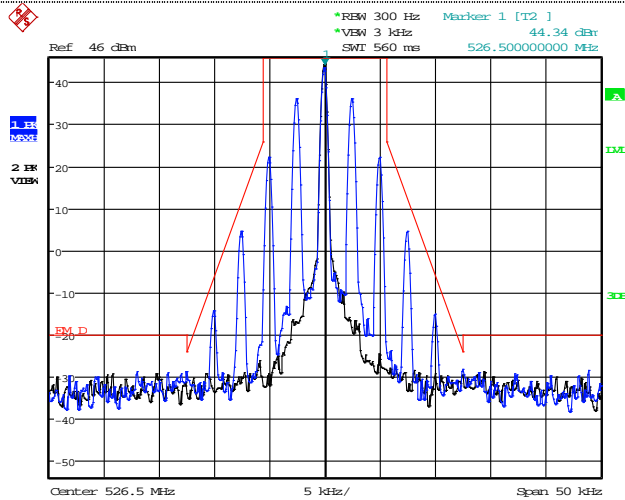

Date: 29.MAY.2014 11:05:33

Highest CH

Modulation Type

4FSK

Operation Mode

Op 5

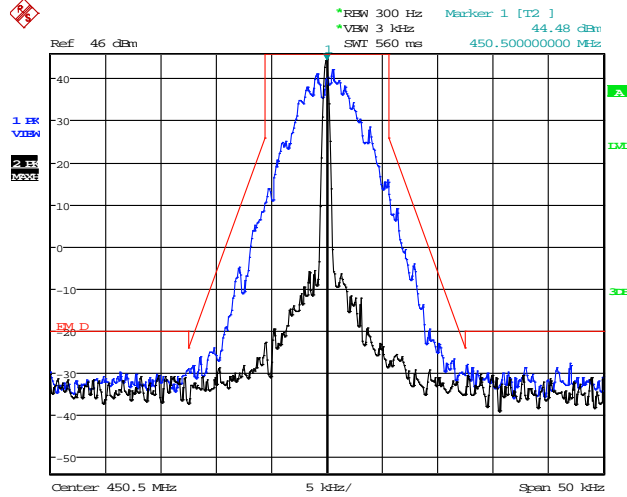

Date: 23.MAY.2014 20:18:11

Lowest CH

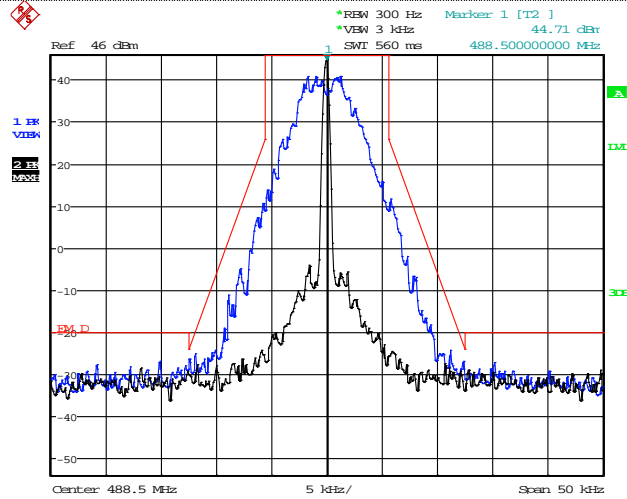

Date: 29.MAY.2014 10:47:32

Middle CH

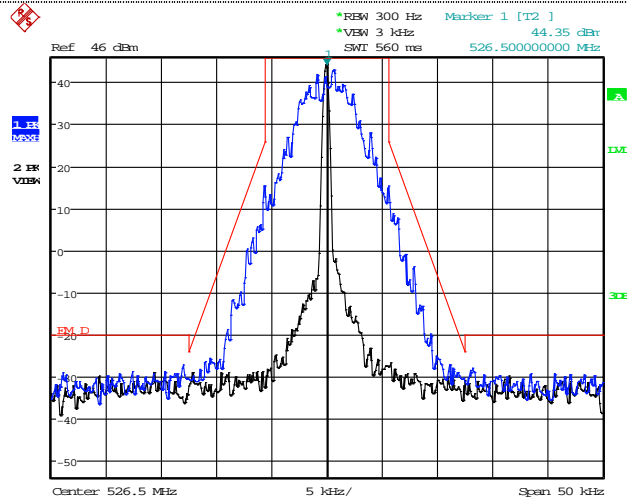

Date: 29.MAY.2014 10:50:50

Highest CH

Modulation Type

4FSK

Operation Mode

Op 6

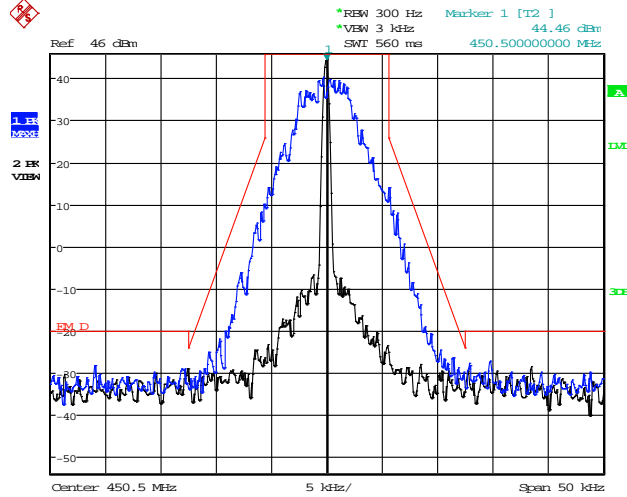

Date: 23.MAY.2014 20:17:08

Lowest CH

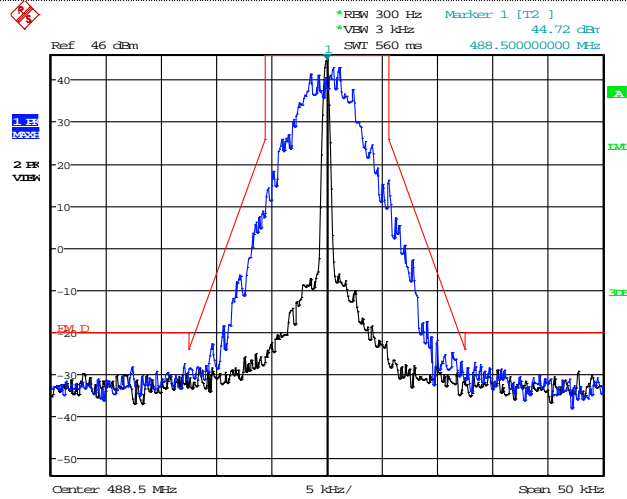

Date: 29.MAY.2014 10:58:36

Middle CH

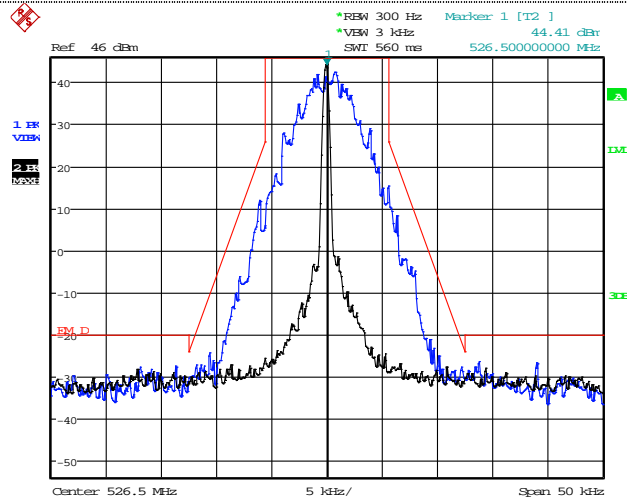

Date: 29.MAY.2014 10:56:44

Highest CH

4.3. Transmitter Radiated Spurious Emission

TEST APPLICABLE

According to the TIA/EIA 603 test method, and according to Section 90.210, the power of each unwanted emission shall be less than Transmitted Power as specified below for transmitters designed to operate with 12.5 KHz channel bandwidth:

- 1 On any frequency removed from the center of the authorized bandwidth f_0 to 5.625 KHz removed from f_0 : Zero dB
 - 2 On any frequency removed from the center of the authorized bandwidth by a displacement frequency (f_d in KHz) f_0 of more than 5.625 KHz but no more than 12.5 KHz: At least 7.27dB
 - 3 On any frequency removed from the center of the authorized bandwidth by a displacement frequency (f_d in KHz) f_0 of more than 12.5 KHz: At least $50+10 \log (P)$ dB or 70 dB, which ever is lesser attenuation.
- For transmitters designed to transmit with 25 KHz channel separation and equipped with an audio low-pass filter, the power of any emission must be attenuated below the unmodulated carrier power (P) as following:

- 1 On any frequency removed from the assigned frequency by more than 50 percent, but no more than 100 percent of the authorized bandwidth: At least 25 dB.
- 2 On any frequency removed from the assigned frequency by more than 100 percent, but no more than 250 percent of the authorized bandwidth: At least 35 dB.
- 3 On any frequency removed from the assigned frequency by more than 250 percent of the authorized bandwidth: At least $43+10\text{Log} (P)$ dB.

TEST CONFIGURATION

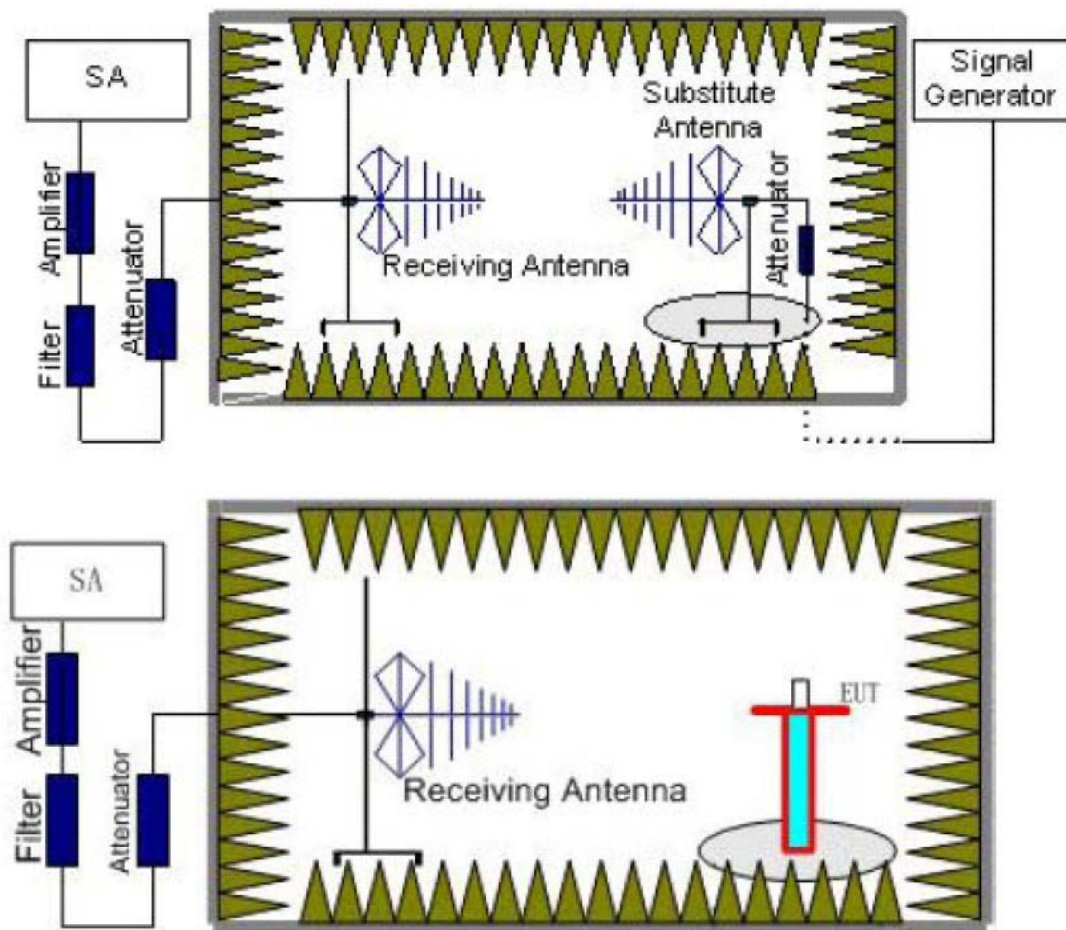

TEST PROCEDURE

1. EUT was placed on a 1.50 meter high non-conductive stand at a 3 meter test distance from the receive antenna. A receiving antenna was placed on the antenna mast 3 meters from the EUT for emission measurements. The height of receiving antenna is 1.50 m. Detected emissions were maximized at each frequency by rotating the EUT through 360° and adjusting the receiving antenna polarization. The radiated emission measurements of all transmit frequencies in six channels were measured with peak detector.

2. A log-periodic antenna or double-ridged waveguide horn antenna shall be substituted in place of the EUT. The log-periodic antenna will be driven by a signal generator and the level will be adjusted till the same power value on the spectrum analyzer or receiver. The level of the spurious emissions can be calculated through the level of the signal generator, cable loss, the gain of the substitution antenna and the reading of the spectrum analyzer or receiver.
3. The EUT is then put into continuously transmitting mode at its maximum power level during the test. Set Test Receiver or Spectrum RBW=1MHz, VBW=3MHz for above 1GHz and RBW=100KHz, VBW=300KHz for 30MHz to 1GHz, And the maximum value of the receiver should be recorded as (P_r).
4. The EUT shall be replaced by a substitution antenna. In the chamber, an substitution antenna for the frequency band of interest is placed at the reference point of the chamber. An RF Signal source for the frequency band of interest is connected to the substitution antenna with a cable that has been constructed to not interfere with the radiation pattern of the antenna. A power (P_{Mea}) is applied to the input of the substitution antenna, and adjust the level of the signal generator output until the value of the receiver reach the previously recorded (P_r). The power of signal source (P_{Mea}) is recorded. The test should be performed by rotating the test item and adjusting the receiving antenna polarization.
5. A amplifier should be connected to the Signal Source output port. And the cable should be connect between the Amplifier and the Substitution Antenna. The cable loss (P_{cl}), the Substitution Antenna Gain (G_a) and the Amplifier Gain (P_{Ag}) should be recorded after test.
The measurement results are obtained as described below:
Power(EIRP)= $P_{Mea} - P_{Ag} - P_{cl} - G_a$
We used SMF100A micowave signal generator which signal level can up to 33dBm,so we not used power Amplifier for substitution test; The measurement results are amend as described below:
Power(EIRP)= $P_{Mea} - P_{cl} - G_a$
6. This value is EIRP since the measurement is calibrated using an antenna of known gain (2.15 dBi) and known input power.
7. ERP can be calculated from EIRP by subtracting the gain of the dipole, ERP = EIRP-2.15dBi.

TEST RESULTS

Remark: We tested Op 1 to Op 8. recorded worst case at Op 1 and Op 5.

Modulation Type: FM

FCC Part 22.359, 74.462, 80.211 and 90.210 and RSS Gen, RSS 119 Issue 11 (12.5 kHz bandwidth only):
On any frequency removed from the center of the authorized bandwidth by a displacement frequency (f_d in kHz) of more than 12.5 kHz at least:

Low: $50 + 10 \log (P_{watts}) = 50 + 10 \log (28.12) = 64.49 \text{ dB}$

High: $50 + 10 \log (P_{watts}) = 50 + 10 \log (29.85) = 64.75 \text{ dB}$

Note: In general, the worse case attenuation requirement shown above was applied.

Calculation: Limit (dBm) = $EL - 50 - 10 \log_{10} (TP)$

Notes: EL is the emission level of the Output Power expressed in dBm,
In this application, the EL is 43.98 dBm.
Limit (dBm) = $43.98 - 50 - 10 \log_{10} (29.85) = -20 \text{ dBm}$

Modulation Type: 4FSK

FCC Part 22.359, 74.462, 80.211 and 90.210 and RSS Gen, RSS 119 Issue 11 (12.5 kHz Bandwidth only):
On any frequency removed from the center of the authorized bandwidth by a displacement frequency (f_d in kHz) of more than 12.5 kHz at least:

Low: $50 + 10 \log (P_{watts}) = 50 + 10 \log (28.58) = 54.56 \text{ dB}$

High: $50 + 10 \log (P_{watts}) = 50 + 10 \log (29.85) = 64.75 \text{ dB}$

Note: In general, the worse case attenuation requirement shown above was applied.

Calculation: Limit (dBm) = $EL - 50 - 10 \log_{10} (TP)$

Notes: EL is the emission level of the Output Power expressed in dBm,
In this application, the EL is 43.98 dBm.
Limit (dBm) = $43.98 - 50 - 10 \log_{10} (29.85) = -20 \text{ dBm}$

Modulation Type:FM							
Operation Mode: Op 1				Channel Separation:12.5KHz			
Test Channel: Lowest CH				Test Frequency: 450.5MHz			
Frequency (MHz)	P _{Mea} (dBm)	Path Loss	Antenna Gain	Correction (dB)	Peak ERP(dBm)	Limit (dBm)	Polarization
901.00	-32.68	0.45	5.36	2.15	-29.92	-20.00	H
1351.5	-43.56	1.12	9.38	2.15	-37.45	-20.00	H
1802.00	-45.25	1.45	9.47	2.15	-39.38	-20.00	H
...	H
901.00	-31.25	0.45	5.36	2.15	-28.49	-20.00	V
1351.5	-42.63	1.12	9.38	2.15	-36.52	-20.00	V
1802.00	-44.25	1.45	9.47	2.15	-38.38	-20.00	V
...	V

Modulation Type:FM							
Operation Mode: Op 1				Channel Separation:12.5KHz			
Test Channel: Middle CH				Test Frequency: 488.5MHz			
Frequency (MHz)	P _{Mea} (dBm)	Path Loss	Antenna Gain	Correction (dB)	Peak ERP(dBm)	Limit (dBm)	Polarization
977.00	-33.25	0.45	5.59	2.15	-30.26	-20.00	H
1465.50	-45.36	1.15	9.67	2.15	-38.99	-20.00	H
1954.00	-47.26	1.50	9.98	2.15	-40.93	-20.00	H
...	H
977.00	-32.75	0.45	5.59	2.15	-29.76	-20.00	V
1465.50	-46.38	1.15	9.67	2.15	-40.01	-20.00	V
1954.00	-45.10	1.50	9.98	2.15	-38.77	-20.00	V
...	V

Modulation Type:FM							
Operation Mode: Op 1				Channel Separation:12.5KHz			
Test Channel: Highest CH				Test Frequency: 526.5MHz			
Frequency (MHz)	P _{Mea} (dBm)	Path Loss	Antenna Gain	Correction (dB)	Peak ERP(dBm)	Limit (dBm)	Polarization
1053.00	-34.69	0.87	6.62	2.15	-31.09	-20.00	H
1579.50	-48.35	1.26	9.83	2.15	-41.93	-20.00	H
2106.00	-49.50	1.72	10.59	2.15	-42.78	-20.00	H
...	H
1053.00	-35.62	0.87	6.62	2.15	-32.02	-20.00	V
1579.50	-47.36	1.26	9.83	2.15	-40.94	-20.00	V
2106.00	-46.37	1.72	10.59	2.15	-39.65	-20.00	V
...	V

- Note: 1. In general, the worse case attenuation requirement shown above was applied.
2. The measurement frequency range from 30 MHz to 6 GHz.
3. *** means that the emission level is too low to be measured or at least 20 dB down than the limit.

Modulation Type:4FSK							
Operation Mode: Op 5				Channel Separation:12.5KHz			
Test Channel: Lowest CH				Test Frequency: 450.5MHz			
Frequency (MHz)	P _{Mea} (dBm)	Path Loss	Antenna Gain	Correction (dB)	Peak ERP(dBm)	Limit (dBm)	Polarization
1219.50	-33.14	0.45	5.36	2.15	-30.38	-20.00	H
2032.50	-45.36	1.12	9.38	2.15	-39.25	-20.00	H
2845.50	-46.72	1.45	9.47	2.15	-40.85	-20.00	H
...	H
1219.50	-34.36	0.45	5.36	2.15	-31.60	-20.00	V
2032.50	-43.68	1.12	9.38	2.15	-37.57	-20.00	V
2845.50	-47.25	1.45	9.47	2.15	-41.38	-20.00	V
...	V

Modulation Type:4FSK							
Operation Mode: Op 5				Channel Separation:12.5KHz			
Test Channel: Middle CH				Test Frequency: 488.5MHz			
Frequency (MHz)	P _{Mea} (dBm)	Path Loss	Antenna Gain	Correction (dB)	Peak ERP(dBm)	Limit (dBm)	Polarization
977.00	-36.35	0.45	5.59	2.15	-33.36	-20.00	H
1465.50	-48.26	1.15	9.67	2.15	-41.89	-20.00	H
1954.00	-50.24	1.50	9.98	2.15	-43.91	-20.00	H
...	H
977.00	-35.10	0.45	5.59	2.15	-32.11	-20.00	V
1465.50	-48.35	1.15	9.67	2.15	-41.98	-20.00	V
1954.00	-47.68	1.50	9.98	2.15	-41.35	-20.00	V
...	V

Modulation Type:4FSK							
Operation Mode: Op 5				Channel Separation:12.5KHz			
Test Channel: Highest CH				Test Frequency: 526.5MHz			
Frequency (MHz)	P _{Mea} (dBm)	Path Loss	Antenna Gain	Correction (dB)	Peak ERP(dBm)	Limit (dBm)	Polarization
1053.00	-34.20	0.87	6.62	2.15	-30.60	-20.00	H
1579.50	-43.65	1.26	9.83	2.15	-37.23	-20.00	H
2106.00	-44.20	1.72	10.59	2.15	-37.48	-20.00	H
...	H
1053.00	-34.47	0.87	6.62	2.15	-30.87	-20.00	V
1579.50	-46.35	1.26	9.83	2.15	-39.93	-20.00	V
2106.00	-47.39	1.72	10.59	2.15	-40.67	-20.00	V
...	V

- Note: 1. In general, the worse case attenuation requirement shown above was applied.
 2. The measurement frequency range from 30 MHz to 6 GHz.
 3. *** means that the emission level is too low to be measured or at least 20 dB down than the limit.

4.4. Spurious Emission on Antenna Port

TEST APPLICABLE

The same as Section 4.3

TEST PROCEDURE

The RF output of the EUT was connected to a spectrum analyzer through appropriate attenuation. The resolution bandwidth of the spectrum analyzer was set to 100 kHz. Sufficient scans were taken to show any out of band emission up to 10th. Harmonic for the lower and the highest frequency range. Set RBW 100 kHz, VBW 300 kHz in the frequency band 30MHz to 1GHz, while set RBW=1MHz. VBW=3MHz from the 1GHz to 10th Harmonic.

The audio input was set to 0 to get the unmodulated carrier, the resulting picture is print out for each channel separation.

TEST CONFIGURATION

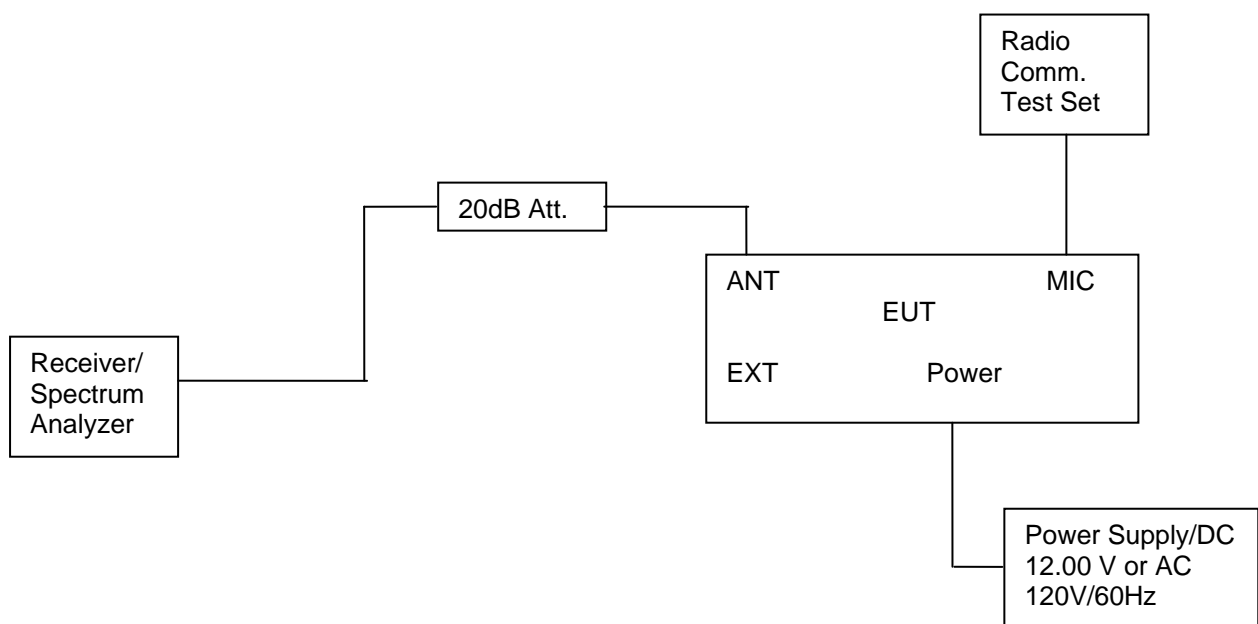

TEST RESULTS

Remark: We tested Op 1 to Op 8. recorded worst case at Op 1 and Op 5.

Modulation Type: FM

FCC Part 22.359, 74.462, 80.211 and 90.210 and RSS Gen, RSS 119 Issue 11 (12.5 kHz bandwidth only):
On any frequency removed from the center of the authorized bandwidth by a displacement frequency (f_d in kHz) of more than 12.5 kHz at least:

Low: $50 + 10 \log (P_{\text{watts}}) = 50 + 10 \log (28.12) = 64.49 \text{ dB}$

High: $50 + 10 \log (P_{\text{watts}}) = 50 + 10 \log (29.85) = 64.75 \text{ dB}$

Note: In general, the worse case attenuation requirement shown above was applied.

Calculation: Limit (dBm) = $EL - 50 - 10 \log_{10} (TP)$

Notes: EL is the emission level of the Output Power expressed in dBm,

In this application, the EL is 43.98 dBm.

Limit (dBm) = $43.98 - 50 - 10 \log_{10} (29.85) = -20 \text{ dBm}$

Modulation Type: 4FSK

FCC Part 22.359, 74.462, 80.211 and 90.210 and RSS Gen, RSS 119 Issue 11 (12.5 kHz Bandwidth only):
On any frequency removed from the center of the authorized bandwidth by a displacement frequency (f_d in kHz) of more than 12.5 kHz at least:

Low: $50 + 10 \log (P_{\text{watts}}) = 50 + 10 \log (28.58) = 54.56 \text{ dB}$

High: $50 + 10 \log (P_{\text{watts}}) = 50 + 10 \log (29.85) = 64.75 \text{ dB}$

Note: In general, the worse case attenuation requirement shown above was applied.

Calculation: Limit (dBm) =EL-50-10log10 (TP)

Notes: EL is the emission level of the Output Power expressed in dBm,
In this application, the EL is 43.98 dBm.

Limit (dBm) =43.98-50-10log10 (29.85) = -20 dBm

Operation Mode	Test Channel	Test Frequency (MHz)	Maximum Conducted Spurious Emissions Below 1GHz		Maximum Conducted Spurious Emissions Above 1GHz	
			Frequency (MHz)	Datum (dBm)	Frequency (MHz)	Datum (dBm)
Op 1	Lowest CH	450.5	901.60	-45.61	1350.00	-41.87
	Middle CH	488.5	977.60	-43.99	3150.00	-44.25
	Highest CH	526.5	639.20	-42.54	1050.00	-28.63
Op 5	Lowest CH	450.5	901.60	-44.56	1350.00	-41.42
	Middle CH	488.5	977.60	-45.72	1460.00	-46.95
	Highest CH	526.5	636.00	-42.63	1050.00	-28.93
Limit			-20dBm for 12.5KHz Channel Separation			
Test Results			PASS			

Note: 1. In general, the worse case attenuation requirement shown above was applied.
2. The measurement frequency range from 30 MHz to 6GHz.

Test plot as follows:

FM Modulation

Operation Mode Op 1 Test Channel Lowest CH

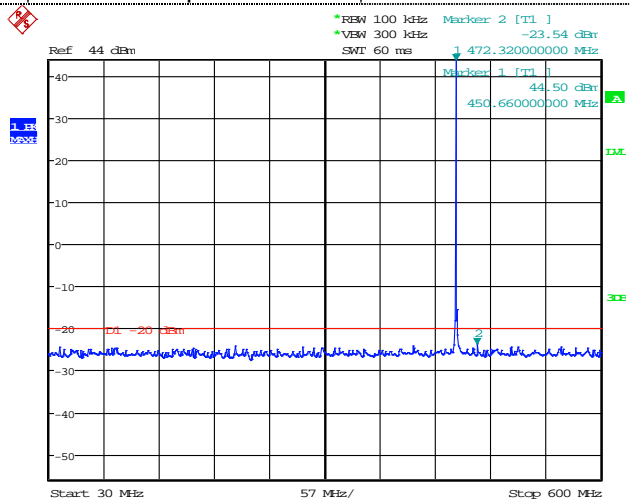

Date: 23.MAY.2014 21:30:11

30MHz-600MHz

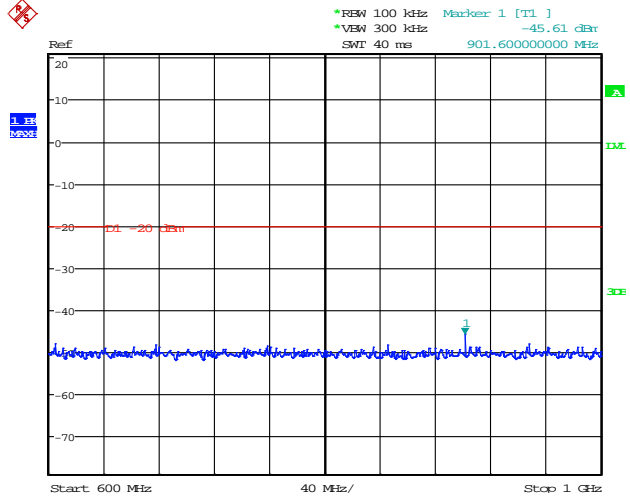

Date: 23.MAY.2014 22:07:19

600MHz-1GHz

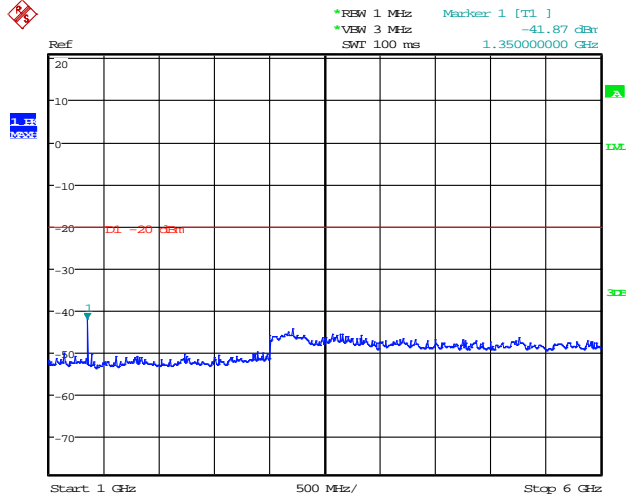

Date: 23.MAY.2014 22:07:37

1GHz-6GHz

Operation Mode	Op 1	Test Channel	Middle CH
----------------	------	--------------	-----------

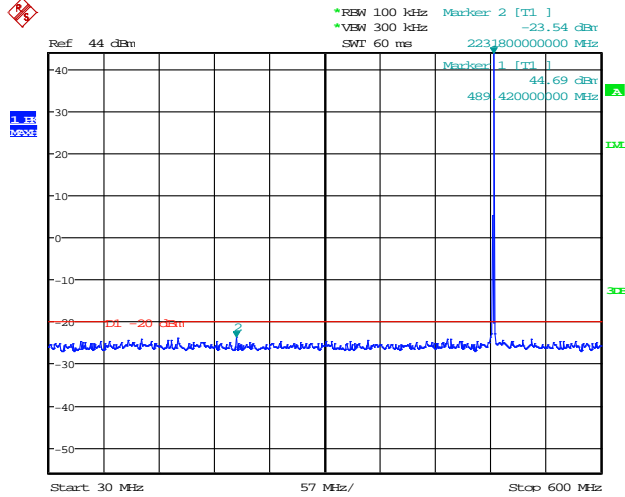

Date: 29.MAY.2014 11:26:24

30MHz-600MHz

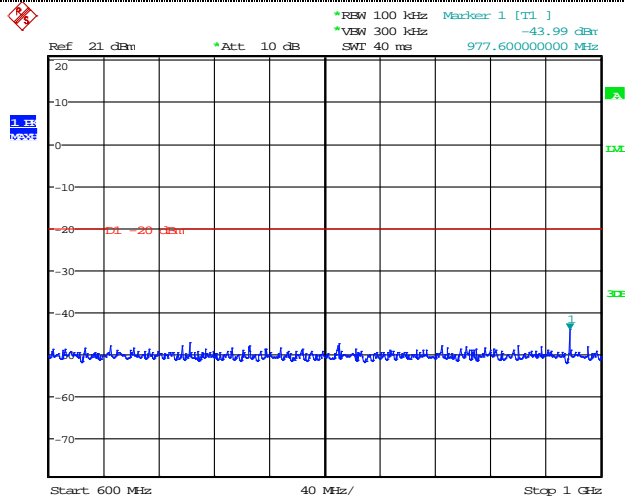

Date: 29.MAY.2014 11:49:55

600MHz-1GHz

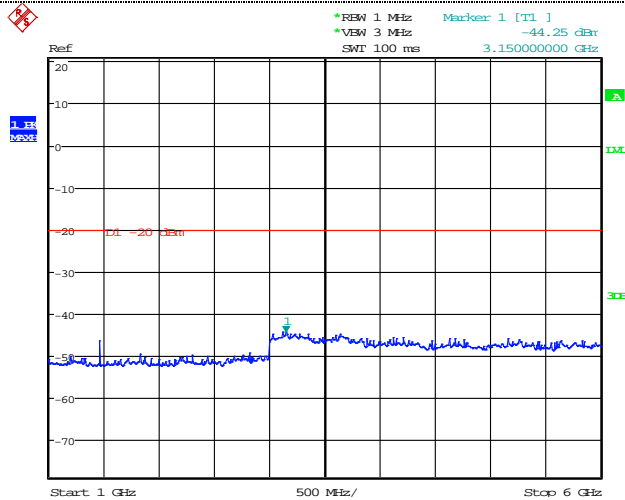

Date: 29.MAY.2014 11:53:04

1GHz-6GHz

Operation Mode	Op 1	Test Channel	Highest CH
----------------	------	--------------	------------

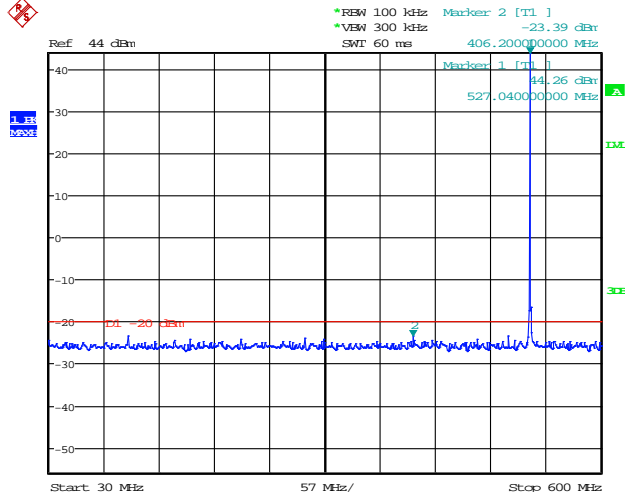

Date: 29.MAY.2014 11:29:26

30MHz-600MHz

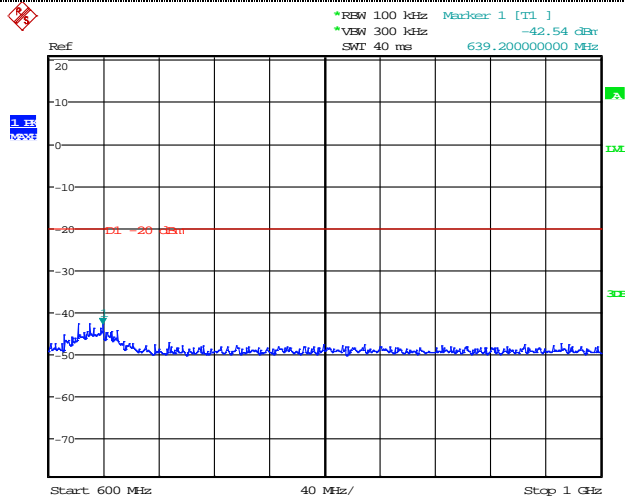

Date: 29.MAY.2014 13:40:59

600MHz-1GHz

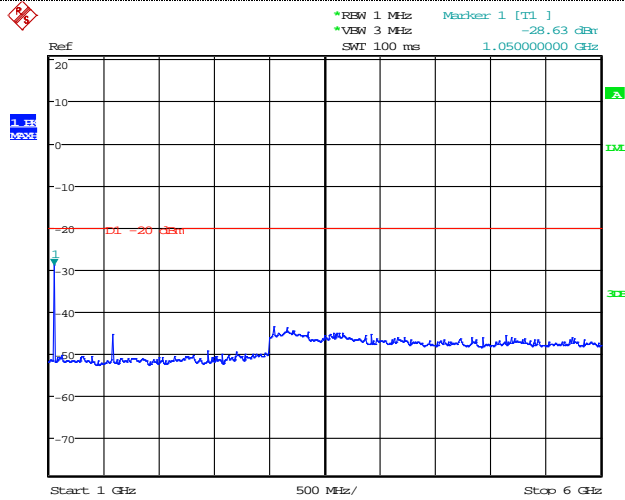

Date: 29.MAY.2014 13:45:05

1GHz-6GHz

4FSK Modulation

Operation Mode Op 5 Test Channel Lowest CH

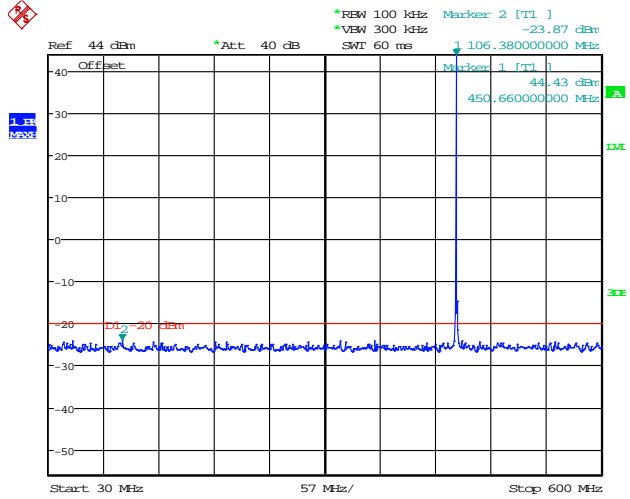

Date: 23.MAY.2014 21:50:19

30MHz-600MHz

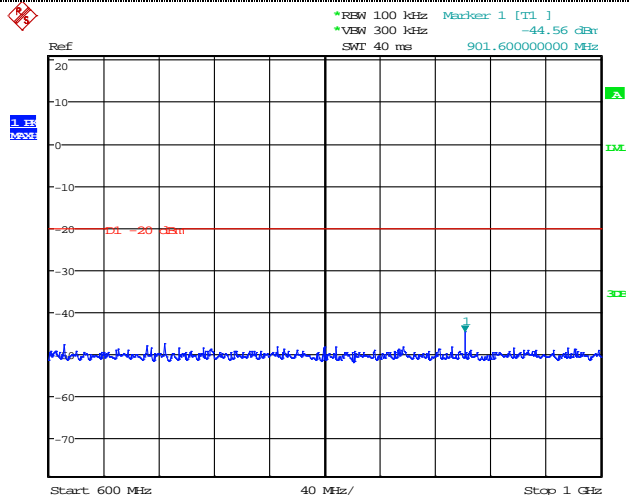

Date: 23.MAY.2014 22:19:07

600MHz-1GHz

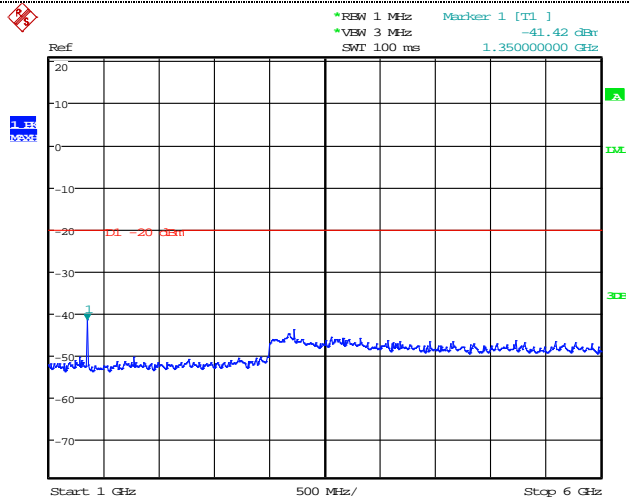

Date: 23.MAY.2014 22:19:26

1GHz-6GHz

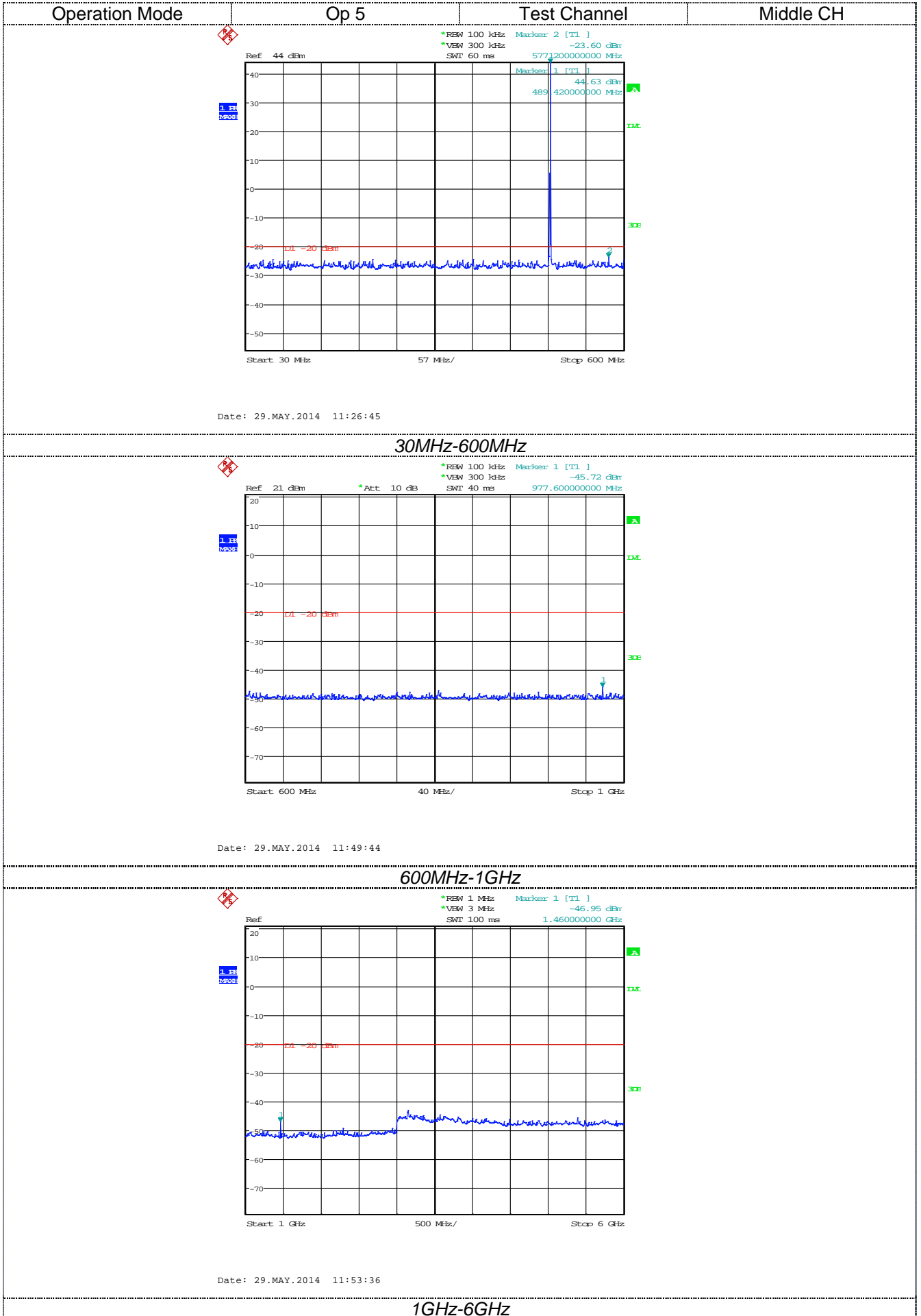

Operation Mode	Op 5	Test Channel	Highest CH
----------------	------	--------------	------------

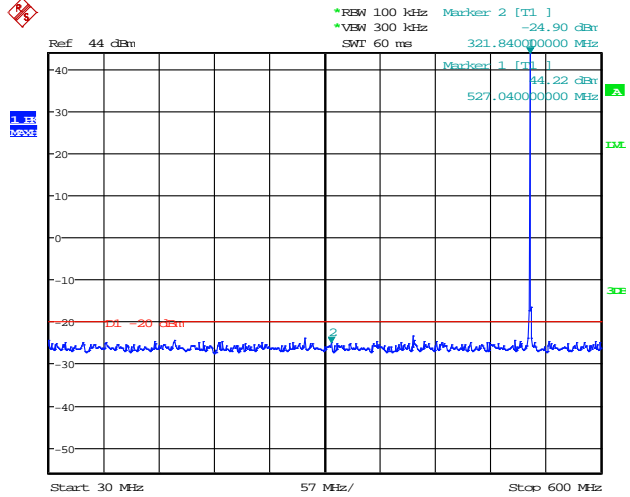

Date: 29.MAY.2014 11:29:05

30MHz-600MHz

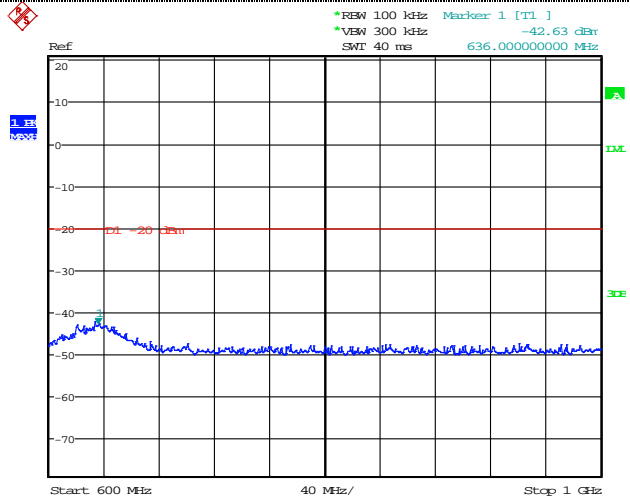

Date: 29.MAY.2014 13:40:19

600MHz-1GHz

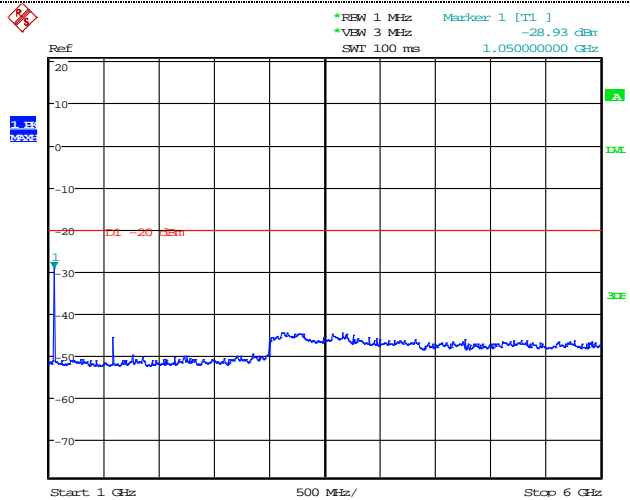

Date: 29.MAY.2014 13:44:31

1GHz-6GHz

4.5. Modulation Characteristics

TEST APPLICABLE

According to CFR47 section 2.1047(a), for Voice Modulation Communication Equipment, the frequency response of the audio modulation circuit over a range of 100 to 5000Hz shall be measured.

TEST PROCEDURE

Modulation Limit

- 1 Configure the EUT as shown in figure 1, adjust the audio input for 60% of rated system deviation at 1 KHz using this level as a reference (0dB) and vary the input level from -20 to +20dB. Record the frequency deviation obtained as a function of the input level.
- 2 Repeat step 1 with input frequency changing to 300, 1004, 1500 and 2500Hz in sequence.

Audio Frequency Response

- 1 Configure the EUT as shown in figure 1.
- 2 Adjust the audio input for 20% of rated system deviation at 1 KHz using this level as a reference (0dB).
- 3 Vary the Audio frequency from 100 Hz to 3 KHz and record the frequency deviation.
- 4 Audio Frequency Response = $20\log_{10}$ (Deviation of test frequency/Deviation of 1 KHz reference).

TEST CONFIGURATION

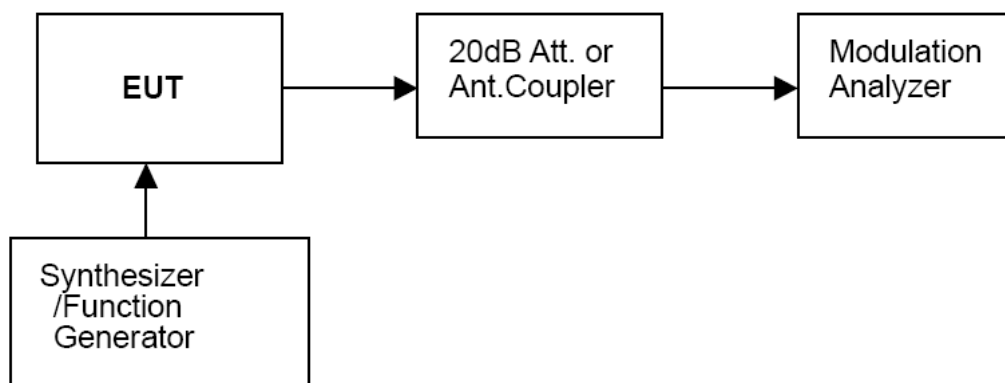

TEST RESULTS

Remark: We tested Op 1 to Op 4. recorded worst case at Op 1.

Modulation Type: FM

12.5 KHz Channel Separation

Modulation Level (dB)	Peak Freq. Deviation At 300 Hz (KHz)	Peak Freq. Deviation At 1004 Hz (KHz)	Peak Freq. Deviation At 1500 Hz (KHz)	Peak Freq. Deviation At 2500 Hz (KHz)
-20	0.14	0.29	0.36	0.56
-15	0.28	0.45	0.45	0.68
-10	0.36	0.69	0.79	1.25
-5	0.47	1.01	1.36	2.10
0	0.56	1.52	2.15	2.32
+5	0.79	2.12	2.30	2.35
+10	1.25	2.35	2.30	2.35
+15	2.27	2.36	2.30	2.35
+20	2.36	2.39	2.30	2.35

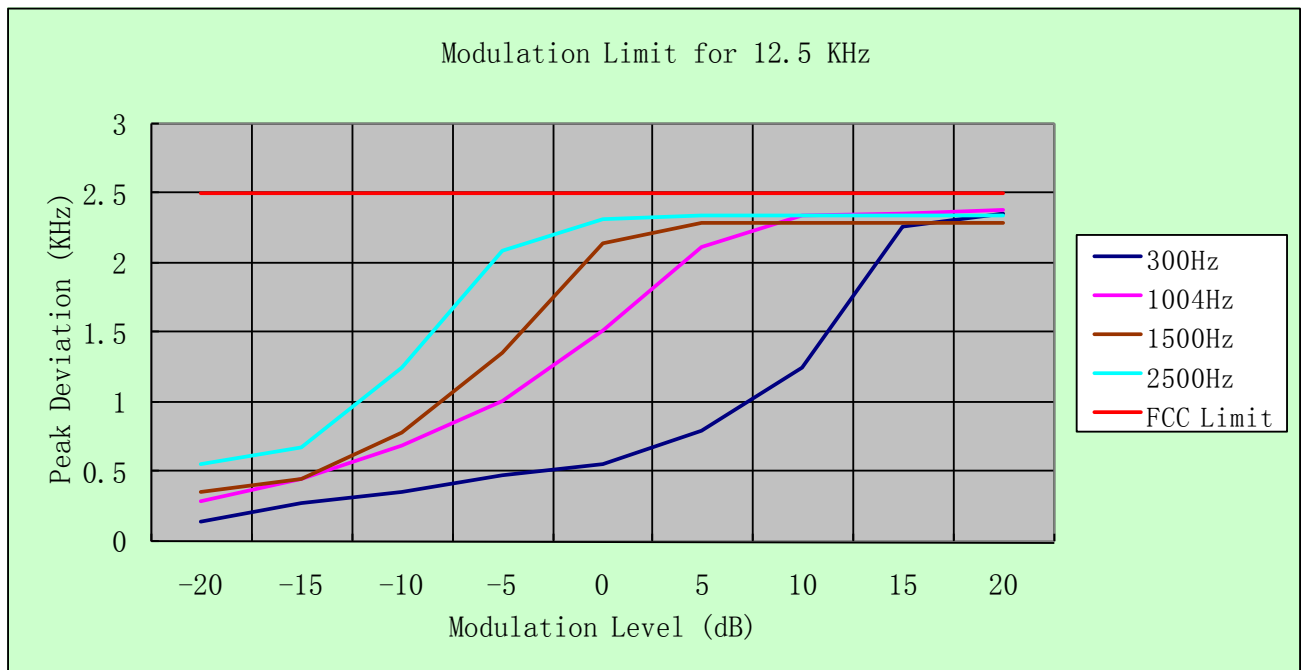

Modulation type: 4FSK

Channel bandwidth: 12.5 kHz

It is not applicable for devices which operate with the digitized voice/data modulation type.

b). Audio Frequency Response:**Rule Part No.: Part 2.1407(a) (b)****Method of Measurement:**

The audio frequency response was measured in accordance with TIA/EIA Specification 603 with no exception. A curve or equivalent data showing the frequency response of the audio modulating circuit over a range of 300-3000Hz shall be submitted and Audio Post Limiter Low Pass Filter Response from 3.0 KHz to 50KHz. However, the audio frequency response should test from 100Hz to 5.0 KHz according to FCC Part 90.

Modulation Type: FM

The audio frequency response curve is show below.and

Test Audio Level (1 KHz and 20% maximum deviation) for 12.5 KHz channel separation is 2.80mv.

Note:

1. Not applicable to new standard. However, tests are conducted under FCC's recommendation.
2. The Audio Frequency Response is identical for 12.5 KHz channel separation

12.5 KHz Channel Separation

Frequency (KHz)	Frequency Deviation (KHz)	1KHz Refenerce Deviation (KHz)	Audio Frequency Response (dB)
0.1	0.05	0.51	-20.17
0.2	0.05	0.51	-20.17
0.3	0.10	0.51	-14.15
0.4	0.13	0.51	-11.87
0.5	0.17	0.51	-9.54
0.6	0.25	0.51	-6.19
0.7	0.32	0.51	-4.05
0.8	0.34	0.51	-3.52
0.9	0.41	0.51	-1.90
1.0	0.47	0.51	-0.71
1.2	0.51	0.51	0.00
1.4	0.58	0.51	1.12
1.6	0.68	0.51	2.50
1.8	0.72	0.51	3.00
2.0	0.79	0.51	3.80
2.2	1.01	0.51	5.94
2.4	1.05	0.51	6.27
2.6	1.13	0.51	6.91
2.7	1.20	0.51	7.43
2.8	1.20	0.51	7.43
3.0	1.22	0.51	7.58
3.5	0.05	0.51	-20.17
4.0	0.05	0.51	-20.17
4.5	0.05	0.51	-20.17
5.0	0.05	0.51	-20.17

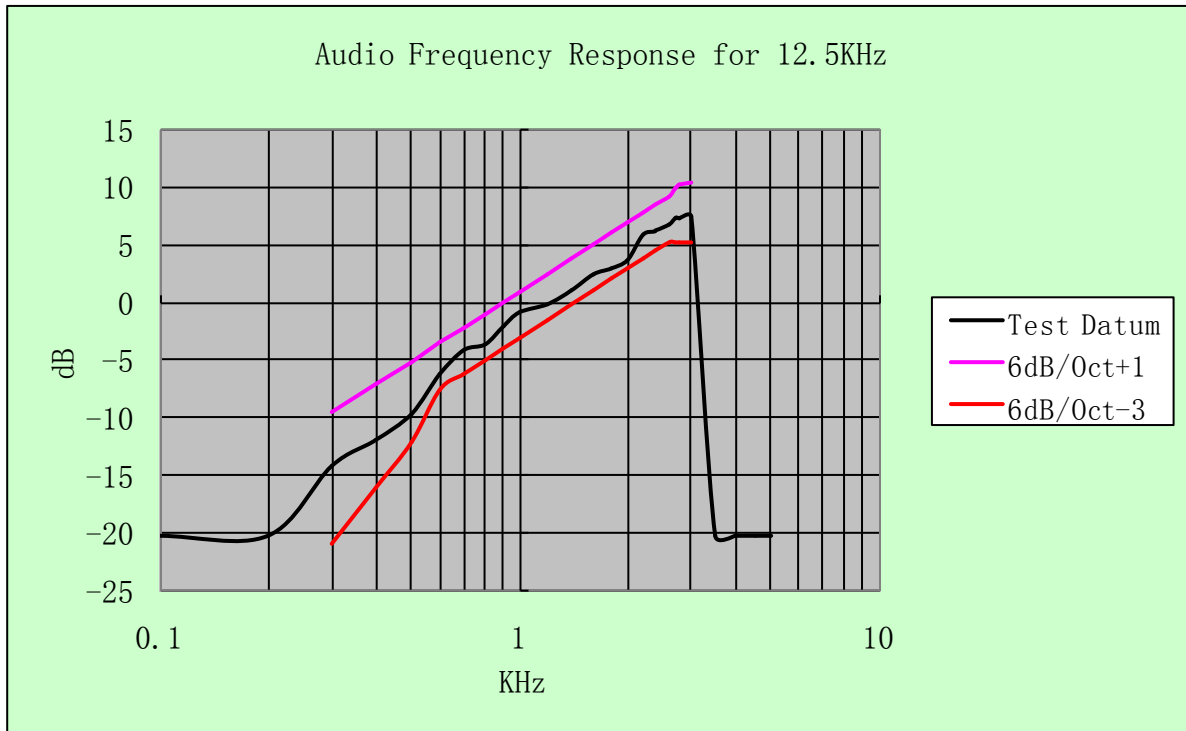

Modulation type: 4FSK

Channel bandwidth: 12.5 kHz

It is not applicable for devices which operate with the digitized voice/data modulation type.