



# TEST REPORT

**Report Reference No.**..... : **TRE17050151** R/C.....: 48870  
**FCC ID**..... : **YAMPTC760FXB1**  
**Applicant's name**..... : **Hytera Communications Corporation Limited**  
 Address.....: Hytera Tower, Hi-Tech Industrial Park North, 9108# Beihuan Road, Nanshan District, Shenzhen, People's Republic of China  
 Manufacturer.....: Hytera Communications Corporation Limited  
 Address.....: Hytera Tower, Hi-Tech Industrial Park North, 9108# Beihuan Road, Nanshan District, Shenzhen, People's Republic of China  
**Test item description** ..... : **Multi-mode Advanced Radio**  
 Trade Mark .....: Hytera  
 Model/Type reference.....: PTC760 FxB1  
 Listed Model(s).....: -  
**Standard** ..... : **FCC 47 CFR Part 2.1093**  
**ANSI/IEEE C95.1: 1999**  
**IEEE 1528: 2013**  
 Date of receipt of test sample.....: May 17, 2017  
 Date of testing.....: May 18, 2017 - Jul. 03, 2017  
 Date of issue.....: Jul. 30, 2017  
**Result**.....: **PASS**

Compiled by  
 ( position+printedname+signature)....: File administrators: Siyuan Rao

*Siyuan Rao*

Supervised by  
 ( position+printedname+signature)....: Test Engineer: Siyuan Rao

*Siyuan Rao*

Approved by  
 ( position+printedname+signature)....: Manager: Hans Hu

*Hans Hu*

**Testing Laboratory Name** ..... : **Shenzhen Huatongwei International Inspection Co., Ltd**  
 Address.....: 1/F, Bldg 3, Hongfa Hi-tech Industrial Park, Genyu Road, Tianliao, Gongming, Shenzhen, China

**Shenzhen Huatongwei International Inspection Co., Ltd. All rights reserved.**

This publication may be reproduced in whole or in part for non-commercial purposes as long as the Shenzhen Huatongwei International Inspection Co., Ltd is acknowledged as copyright owner and source of the material. Shenzhen Huatongwei International Inspection Co., Ltd takes no responsibility for and will not assume liability for damages resulting from the reader's interpretation of the reproduced material due to its placement and context.

*The test report merely corresponds to the test sample.  
 It is not permitted to copy extracts of these test result without the written permission of the test laboratory.*

## Contents

<u>1.</u>	<u>Test Standards and Report version</u>	<u>3</u>
1.1.	Test Standards	3
1.2.	Report version	3
<u>2.</u>	<u>Summary</u>	<u>4</u>
2.1.	Client Information	4
2.2.	Product Description	4
<u>3.</u>	<u>Test Environment</u>	<u>6</u>
3.1.	Test laboratory	6
3.2.	Test Facility	6
<u>4.</u>	<u>Equipments Used during the Test</u>	<u>7</u>
<u>5.</u>	<u>Measurement Uncertainty</u>	<u>8</u>
<u>6.</u>	<u>SAR Measurements System Configuration</u>	<u>10</u>
6.1.	SAR Measurement Set-up	10
6.2.	DASY5 E-field Probe System	11
6.3.	Phantoms	12
6.4.	Device Holder	13
<u>7.</u>	<u>SAR Test Procedure</u>	<u>14</u>
7.1.	Scanning Procedure	14
7.2.	Data Storage and Evaluation	16
<u>8.</u>	<u>Position of the wireless device in relation to the phantom</u>	<u>18</u>
8.1.	Head Position	18
8.2.	Body Position	19
8.3.	Hotspot Mode Exposure conditions	19
8.4.	Front-of-face	20
8.5.	Body Position	20
<u>9.</u>	<u>System Check</u>	<u>21</u>
9.1.	Tissue Dielectric Parameters	21
9.2.	SAR System Check	24
<u>10.</u>	<u>SAR Exposure Limits</u>	<u>39</u>
<u>11.</u>	<u>Conducted Power Measurement Results</u>	<u>40</u>
<u>12.</u>	<u>Maximum Tune-up Limit</u>	<u>60</u>
<u>13.</u>	<u>Antenna Location</u>	<u>62</u>
<u>14.</u>	<u>SAR Measurement Results</u>	<u>63</u>
<u>15.</u>	<u>Simultaneous Transmission analysis</u>	<u>108</u>
<u>16.</u>	<u>TestSetup Photos</u>	<u>119</u>
<u>17.</u>	<u>External and Internal Photos of the EUT</u>	<u>125</u>

## 1 . Test Standards and Report version

### 1.1. Test Standards

The tests were performed according to following standards:

[FCC 47 Part 2.1093](#) Radiofrequency Radiation Exposure Evaluation: Portable Devices

[IEEE Standard C95.1, 1999](#): IEEE Standard for Safety Levels with Respect to Human Exposure to Radio Frequency Electromagnetic Fields, 3 KHz to 300 GHz.

[IEEE Standard 1528™-2013](#): IEEE Recommended Practice for Determining the Peak Spatial-Average Specific Absorption Rate (SAR) in the Human Head from Wireless Communications Devices: Measurement Techniques.

[KDB 865664 D01 SAR Measurement 100 MHz to 6 GHz v01r04](#): SAR Measurement Requirements for 100 MHz to 6 GHz

[KDB 865664 D02 RF Exposure Reporting v01r02](#): RF Exposure Compliance Reporting and Documentation Considerations

[KDB 447498 D01 General RF Exposure Guidance v06](#): Mobile and Portable Device RF Exposure Procedures and Equipment Authorization Policies

[KDB248227 D01 802.11 Wi-Fi SAR v02r02](#): SAR Measurement Procedures for 802.11 a/b/g Transmitters

[KDB 648474 D04 Handset SAR v01r03](#): SAR Evaluation Considerations for Wireless Handsets

[KDB 616217 D04 SAR for laptop and tablets v01r02](#): SAR Evaluation Considerations for Laptop, Notebook, Netbook and Tablet Computers

[KDB941225 D01 3G SAR Procedures v03r01](#): SAR Measurement Procedures for 3G Devices

[KDB 941225 D06 Hotspot Mode v02r01](#): SAR Evaluation Procedures for Portable Devices with Wireless Router Capabilities

[KDB941225 D05 SAR for LTE Devices v02r04](#): SAR Evaluation Considerations for LTE Devices

[KDB 643646 D01: SAR Test for PTT Radios v01r03](#): SAR Test Reduction Considerations for Occupational PTT Radios

### 1.2. Report version

Version No.	Date of issue	Description
00	Jul. 30, 2017	Original

## 2. Summary

### 2.1. Client Information

Applicant:	Hytera Communications Corporation Limited
Address:	Hytera Tower, Hi-Tech Industrial Park North, 9108# Beihuan Road, Nanshan District, Shenzhen, People's Republic of China
Manufacturer:	Hytera Communications Corporation Limited
Address:	Hytera Tower, Hi-Tech Industrial Park North, 9108# Beihuan Road, Nanshan District, Shenzhen, People's Republic of China

### 2.2. Product Description

Name of EUT	Multi-mode Advanced Radio				
Trade Mark:	Hytera				
Model No.:	PTC760 FxB1				
Listed Model(s):	-				
Power supply:	DC 7.6V				
Device Category:	Portable				
Product stage:	Production unit				
RF Exposure Environment:	Occupational / Controlled:	For TETRA function			
	General Population / Uncontrolled:	For GSM, LTE, WIFI functions.			
IMEI:	359434070000383				
Hardware version:	V1.0				
Software version:	R1.0				
<b>Maximum SAR Value</b>					
Separation Distance:	TETRA Function				
	Front of Face:	25mm			
	Body(Without Back Clip) :	10mm			
	Body(With Back Clip) :	0mm			
	GSM/LTE/WIFI Function				
	Face:	0mm			
	Body:	10mm			
Max Report SAR Value (1g):	Test location:	PCE	DTS	PTT	Simultaneous
	Head:	0.402 W/Kg	0.281 W/Kg	-	0.733 W/Kg
	Body:	0.280 W/Kg	0.144 W/Kg	2.04 W/Kg	#
	Hotspot:	0.280 W/Kg	0.144 W/Kg	-	0.446 W/Kg
	Front of Face:	-	-	1.51 W/Kg	1.510 W/Kg

Note:

#: Please refer to the section 15.

According to KDB 447498 Section 7.2, Simultaneous transmission SAR test exclusion applies when the sum of the SAR ratios for all simultaneously transmitting antennas incorporated in a host device is  $\leq 1.0$ , the SAR ratio  $< 1.0$ , so comply for the standard requirement.

<b>PTT</b>	
Operation Band:	450MHz ~ 470MHz
Modulation Type:	$\pi/4$ DQPSK
Working Mode:	TMO, DMO
Channel Separation:	25kHz
Antenna type:	External Antenna
<b>GSM</b>	
Support Network:	GSM, GPRS, EGPRS
Support Band:	GSM850, PCS1900
Modulation:	GSM/GPRS/EGPRS: GMSK EGPRS:8PSK
Transmit Frequency:	GSM850: 824.20MHz-848.80MHz PCS1900: 1850.20MHz-1909.80MHz
Receive Frequency:	GSM850: 869.20MHz-893.80MHz PCS1900: 1930.20MHz-1989.80MHz
GPRS Class:	12
EGPRS Class:	12
Antenna type:	Intergal Antenna
<b>LTE</b>	
Operation Band:	FDD Band 2,FDD Band 4, FDD Band 5,FDD Band 7, FDD Band 26, TDD Band 41
Modulation Type:	QPSK , 16QAM
Antenna type:	Intergal Antenna
<b>WIFI</b>	
Supported type:	802.11b/802.11g/802.11n(H20)
Modulation:	802.11b: DSSS (DBPSK / DQPSK / CCK) 802.11g/n(H20): OFDM (BPSK / QPSK / 16QAM / 64QAM)
Operation frequency:	802.11b/g/n(H20): 2412MHz~2462MHz
Channel number:	802.11b/g/n(H20): 11
Channel separation:	5MHz
Antenna type:	Internal Antenna
<b>Bluetooth+EDR</b>	
Version:	Supported BT4.0+EDR
Modulation:	GFSK, $\pi/4$ DQPSK, 8DPSK
Operation frequency:	2402MHz~2480MHz
Channel number:	79
Channel separation:	1MHz
Antenna type:	Integral Antenna
<b>Bluetooth+BLE</b>	
Version:	Supported BT4.0+BLE
Modulation:	GFSK
Operation frequency:	2402MHz~2480MHz
Channel number:	40
Channel separation:	2MHz
Antenna type:	Integral Antenna

### **3. Test Environment**

#### **3.1. Test laboratory**

Laboratory: Shenzhen Huatongwei International Inspection Co., Ltd.

Address: 1/F, Bldg 3, Hongfa Hi-tech Industrial Park, Genyu Road, Tianliao, Gongming, Shenzhen, China

#### **3.2. Test Facility**

##### **CNAS-Lab Code: L1225**

Shenzhen Huatongwei International Inspection Co., Ltd. has been assessed and proved to be in compliance with CNAS-CL01 Accreditation Criteria for Testing and Calibration Laboratories (identical to ISO/IEC17025:2005 General Requirements) for the Competence of Testing and Calibration Laboratories

##### **A2LA-Lab Cert. No. 3902.01**

Shenzhen Huatongwei International Inspection Co., Ltd. EMC Laboratory has been accredited by A2LA for technical competence in the field of electrical testing, and proved to be in compliance with ISO/IEC 17025: 2005 General Requirements for the Competence of Testing and Calibration Laboratories and any additional program requirements in the identified field of testing.

##### **FCC-Registration No.: 762235**

Shenzhen Huatongwei International Inspection Co., Ltd. EMC Laboratory has been registered and fully described in a report filed with the FCC (Federal Communications Commission). The acceptance letter from the FCC is maintained in our files.

##### **IC-Registration No.:5377B**

Two 3m Alternate Test Site of Shenzhen Huatongwei International Inspection Co., Ltd. has been registered by Certification and Engineering Bureau of Industry Canada for the performance of radiated measurements with Registration No.: 5377B

##### **ACA**

Shenzhen Huatongwei International Inspection Co., Ltd. EMC Laboratory can also perform testing for the Australian C-Tick mark as a result of our A2LA accreditation.

#### 4. Equipments Used during the Test

Test Equipment	Manufacturer	Type/Model	Serial Number	Calibration	
				Last Calibration	Calibration Interval
Data Acquisition Electronics DAEx	SPEAG	DAE4	1315	2016/07/26	1
E-field Probe	SPEAG	ES3DV3	3292	2016/09/02	1
System Validation Dipole D450V3	SPEAG	D450V3	1079	2016/02/28	3
System Validation Dipole D835V2	SPEAG	D835V2	4d134	2014/07/24	3
System Validation Dipole D1750V2	SPEAG	D1750V2	1062	2015/07/25	3
System Validation Dipole D1900V2	SPEAG	D1900V2	5d101	2015/07/23	3
System Validation Dipole D2450V2	SPEAG	D2450V2	884	2015/09/01	3
System Validation Dipole D2600V2	SPEAG	D2600V2	1120	2016/02/03	3
Dielectric Probe Kit	Agilent	85070E	US44020288	/	/
Power meter	Agilent	E4417A	GB41292254	2016/10/25	1
Power sensor	Agilent	8481H	MY41095360	2016/10/25	1
Power sensor	Agilent	E9327A	US40441621	2016/10/25	1
Network analyzer	Agilent	8753E	US37390562	2016/10/24	1
Universal Radio Communication Tester	ROHDE & SCHWARZ	CMW500	1556902	2016/12/26	1
Signal Generator	ROHDE & SCHWARZ	SMBV100A	258525	2016/10/22	1
Power Divider	ARRA	A3200-2	N/A	N/A	N/A
Dual Directional Coupler	Agilent	778D	50783	Note	
Attenuator 1	PE	PE7005-10	N/A	Note	
Attenuator 2	PE	PE7005-10	N/A	Note	
Attenuator 3	PE	PE7005-3	N/A	Note	
Power Amplifier	AR	5S1G4M2	0328798	Note	

**Note:**

1. The probe dipole and DAE calibration reference to the Appendix A.
2. Referring to KDB865664 D01, the dipole calibration interval can be extended to 3 years with justification. The dipole are also not physically damaged or repaired during the interval.
3. Prior to system verification and validation, the path loss from the signal generator to the system check source and the power meter, which includes the amplifier, cable, attenuator and directional coupler, was measured by the network analyzer. The reading of the power meter was offset by the path loss difference between the path to the power meter and the path to the system check source to monitor the actual power level fed to the system check source.

## 5. Measurement Uncertainty

Measurement Uncertainty										
No.	Error Description	Type	Uncertainty Value	Probably Distribution	Div.	(Ci) 1g	(Ci) 10g	Std. Unc. (1g)	Std. Unc. (10g)	Degree of freedom
Measurement System										
1	Probe calibration	B	6.0%	N	1	1	1	6.0%	6.0%	∞
2	Axial isotropy	B	4.70%	R	$\sqrt{3}$	0.7	0.7	1.90%	1.90%	∞
3	Hemispherical isotropy	B	9.60%	R	$\sqrt{3}$	0.7	0.7	3.90%	3.90%	∞
4	Boundary Effects	B	1.00%	R	$\sqrt{3}$	1	1	0.60%	0.60%	∞
5	Probe Linearity	B	4.70%	R	$\sqrt{3}$	1	1	2.70%	2.70%	∞
6	Detection limit	B	1.00%	R	$\sqrt{3}$	1	1	0.60%	0.60%	∞
7	RF ambient conditions-noise	B	0.00%	R	$\sqrt{3}$	1	1	0.00%	0.00%	∞
8	RF ambient conditions-reflection	B	0.00%	R	$\sqrt{3}$	1	1	0.00%	0.00%	∞
9	Response time	B	0.80%	R	$\sqrt{3}$	1	1	0.50%	0.50%	∞
10	Integration time	B	5.00%	R	$\sqrt{3}$	1	1	2.90%	2.90%	∞
11	RF ambient	B	3.00%	R	$\sqrt{3}$	1	1	1.70%	1.70%	∞
12	Probe positioned mech. restrictions	B	0.40%	R	$\sqrt{3}$	1	1	0.20%	0.20%	∞
13	Probe positioning with respect to phantom shell	B	2.90%	R	$\sqrt{3}$	1	1	1.70%	1.70%	∞
14	Max.SAR evaluation	B	3.90%	R	$\sqrt{3}$	1	1	2.30%	2.30%	∞
Test Sample Related										
15	Test sample positioning	A	1.86%	N	1	1	1	1.86%	1.86%	∞
16	Device holder uncertainty	A	1.70%	N	1	1	1	1.70%	1.70%	∞
17	Drift of output power	B	5.00%	R	$\sqrt{3}$	1	1	2.90%	2.90%	∞
Phantom and Set-up										
18	Phantom uncertainty	B	4.00%	R	$\sqrt{3}$	1	1	2.30%	2.30%	∞
19	Liquid conductivity (target)	B	5.00%	R	$\sqrt{3}$	0.64	0.43	1.80%	1.20%	∞
20	Liquid conductivity (meas.)	A	0.50%	N	1	0.64	0.43	0.32%	0.26%	∞
21	Liquid permittivity (target)	B	5.00%	R	$\sqrt{3}$	0.64	0.43	1.80%	1.20%	∞
22	Liquid cpermittivity (meas.)	A	0.16%	N	1	0.64	0.43	0.10%	0.07%	∞
Combined standard uncertainty			$u_c = \sqrt{\sum_{i=1}^{22} c_i^2 u_i^2}$	/	/	/	/	9.79%	9.67%	∞
Expanded uncertainty (confidence interval of 95 %)			$u_e = 2u_c$	R	K=2	/	/	19.57%	19.34%	∞



System Check Uncertainty										
No.	Error Description	Type	Uncertainty Value	Probably Distribution	Div.	(Ci) 1g	(Ci) 10g	Std. Unc. (1g)	Std. Unc. (10g)	Degree of freedom
Measurement System										
1	Probe calibration	B	6.0%	N	1	1	1	6.0%	6.0%	∞
2	Axial isotropy	B	4.70%	R	$\sqrt{3}$	0.7	0.7	1.90%	1.90%	∞
3	Hemispherical isotropy	B	9.60%	R	$\sqrt{3}$	0.7	0.7	3.90%	3.90%	∞
4	Boundary Effects	B	1.00%	R	$\sqrt{3}$	1	1	0.60%	0.60%	∞
5	Probe Linearity	B	4.70%	R	$\sqrt{3}$	1	1	2.70%	2.70%	∞
6	Detection limit	B	1.00%	R	$\sqrt{3}$	1	1	0.60%	0.60%	∞
7	RF ambient conditions-noise	B	0.00%	R	$\sqrt{3}$	1	1	0.00%	0.00%	∞
8	RF ambient conditions-reflection	B	0.00%	R	$\sqrt{3}$	1	1	0.00%	0.00%	∞
9	Response time	B	0.80%	R	$\sqrt{3}$	1	1	0.50%	0.50%	∞
10	Integration time	B	5.00%	R	$\sqrt{3}$	1	1	2.90%	2.90%	∞
11	RF ambient	B	3.00%	R	$\sqrt{3}$	1	1	1.70%	1.70%	∞
12	Probe positioned mech. restrictions	B	0.40%	R	$\sqrt{3}$	1	1	0.20%	0.20%	∞
13	Probe positioning with respect to phantom shell	B	2.90%	R	$\sqrt{3}$	1	1	1.70%	1.70%	∞
14	Max.SAR evaluation	B	3.90%	R	$\sqrt{3}$	1	1	2.30%	2.30%	∞
System validation source-dipole										
15	Deviation of experimental dipole from numerical dipole	A	1.58%	N	1	1	1	1.58%	1.58%	∞
16	Dipole axis to liquid distance	A	1.35%	N	1	1	1	1.35%	1.35%	∞
17	Input power and SAR drift	B	4.00%	R	$\sqrt{3}$	1	1	2.30%	2.30%	∞
Phantom and Set-up										
18	Phantom uncertainty	B	4.00%	R	$\sqrt{3}$	1	1	2.30%	2.30%	∞
20	Liquid conductivity (meas.)	A	0.50%	N	1	0.64	0.43	0.32%	0.26%	∞
22	Liquid cpermittivity (meas.)	A	0.16%	N	1	0.64	0.43	0.10%	0.07%	∞
Combined standard uncertainty		$u_c = \sqrt{\sum_{i=1}^{22} c_i^2 u_i^2}$		/	/	/	/	8.80%	8.79%	∞
Expanded uncertainty (confidence interval of 95 %)		$u_e = 2u_c$		R	K=2	/	/	17.59%	17.58%	∞

## 6. SAR Measurements System Configuration

### 6.1. SAR Measurement Set-up

The DASY5 system for performing compliance tests consists of the following items:

A standard high precision 6-axis robot (Stäubli RX family) with controller and software. An arm extension for accommodating the data acquisition electronics (DAE).

A dosimetric probe, i.e. an isotropic E-field probe optimized and calibrated for usage in tissue simulating liquid. The probe is equipped with an optical surface detector system.

A data acquisition electronic (DAE) which performs the signal amplification, signal multiplexing, AD-conversion, offset measurements, mechanical surface detection, collision detection, etc. The unit is battery powered with standard or rechargeable batteries. The signal is optically transmitted to the EOC.

A unit to operate the optical surface detector which is connected to the EOC.

The Electro-Optical Coupler (EOC) performs the conversion from the optical into a digital electric signal of the DAE. The EOC is connected to the DASY5 measurement server.

The DASY5 measurement server, which performs all real-time data evaluation for field measurements and surface detection, controls robot movements and handles safety operation. A computer operating Windows 2003.

DASY5 software and SEMCAD data evaluation software.

Remote control with teach panel and additional circuitry for robot safety such as warning lamps, etc.

The generic twin phantom enabling the testing of left-hand and right-hand usage.

The device holder for handheld Mobile Phones.

Tissue simulating liquid mixed according to the given recipes.

System validation dipoles allowing to validate the proper functioning of the system.

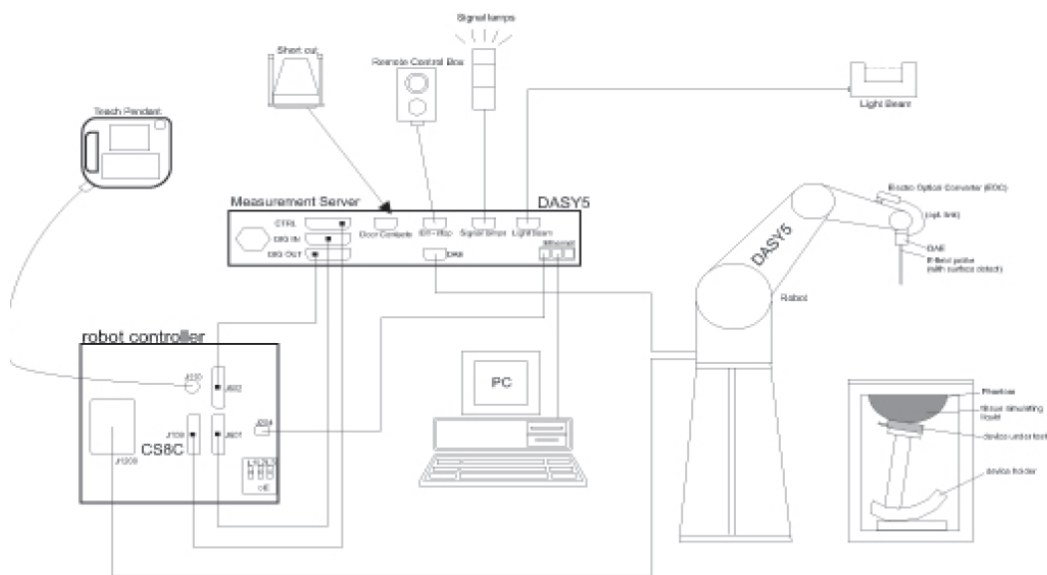

## 6.2. DASY5 E-field Probe System

The SAR measurements were conducted with the dosimetric probe ES3DV3 (manufactured by SPEAG), designed in the classical triangular configuration and optimized for dosimetric evaluation.

### ● Probe Specification

Construction Symmetrical design with triangular core  
 Interleaved sensors  
 Built-in shielding against static charges  
 PEEK enclosure material (resistant to organic solvents, e.g., DGBE)

Calibration ISO/IEC 17025 calibration service available.

Frequency	10 MHz to 4 GHz; Linearity: ± 0.2 dB (30 MHz to 4 GHz)
Directivity	± 0.2 dB in HSL (rotation around probe axis) ± 0.3 dB in tissue material (rotation normal to probe axis)
Dynamic Range	5 µW/g to > 100 mW/g; Linearity: ± 0.2 dB
Dimensions	Overall length: 337 mm (Tip: 20 mm) Tip diameter: 3.9 mm (Body: 12 mm) Distance from probe tip to dipole centers: 2.0 mm
Application	General dosimetry up to 4 GHz Dosimetry in strong gradient fields Compliance tests of Mobile Phones
Compatibility	DASY3, DASY4, DASY52 SAR and higher, EASY4/MRI



### ● Isotropic E-Field Probe

The isotropic E-Field probe has been fully calibrated and assessed for isotropicity, and boundary effect within a controlled environment. Depending on the frequency for which the probe is calibrated the method utilized for calibration will change.

The E-Field probe utilizes a triangular sensor arrangement as detailed in the diagram below:

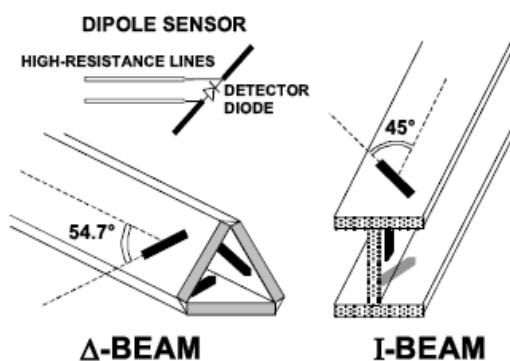

### 6.3. Phantoms

The phantom used for all tests i.e. for both system checks and device testing, was the twin-headed "SAM Phantom", manufactured by SPEAG. The SAM twin phantom is a fiberglass shell phantom with 2mm shell thickness (except the ear region, where shell thickness increases to 6mm).

System checking was performed using the flat section, whilst Head SAR tests used the left and right head profile sections. Body SAR testing also used the flat section between the head profiles.



SAM Twin Phantom

Phantom for compliance testing of handheld and body-mounted wireless devices in the frequency range of 30MHz to 6GHz. ELI is fully compatible with the IEC 62209-2 standard and all known tissue simulating liquids. ELI has been optimized regarding its performance and can be integrated into our standard phantom tables. A cover prevents evaporation of the liquid. Reference markings on the phantom allow installation of the complete setup, including all predefined phantom positions and measurement grids, by teaching three points. The phantom is compatible with all SPEAG dosimetric probes and dipoles.



ELI4 Phantom

#### 6.4. Device Holder

The device was placed in the device holder (illustrated below) that is supplied by SPEAG as an integral part of the DASY system.

The DASY device holder is designed to cope with the different positions given in the standard. It has two scales for device rotation (with respect to the body axis) and device inclination (with respect to the line between the ear reference points). The rotation centers for both scales is the ear reference point (ERP). Thus the device needs no repositioning when changing the angles.



Device holder supplied by SPEAG

## 7. SAR Test Procedure

### 7.1. Scanning Procedure

The DASY5 installation includes predefined files with recommended procedures for measurements and validation. They are read-only document files and destined as fully defined but unmeasured masks. All test positions (head or body-worn) are tested with the same configuration of test steps differing only in the grid definition for the different test positions.

The “reference” and “drift” measurements are located at the beginning and end of the batch process. They measure the field drift at one single point in the liquid over the complete procedure. The indicated drift is mainly the variation of the DUT’s output power and should vary max.  $\pm 5\%$ .

The “surface check” measurement tests the optical surface detection system of the DASY5 system by repeatedly detecting the surface with the optical and mechanical surface detector and comparing the results. The output gives the detecting heights of both systems, the difference between the two systems and the standard deviation of the detection repeatability. Air bubbles or refraction in the liquid due to separation of the sugar-water mixture gives poor repeatability (above  $\pm 0.1\text{mm}$ ). To prevent wrong results tests are only executed when the liquid is free of air bubbles. The difference between the optical surface detection and the actual surface depends on the probe and is specified with each probe (It does not depend on the surface reflectivity or the probe angle to the surface within  $\pm 30^\circ$ .)

#### Area Scan

The Area Scan is used as a fast scan in two dimensions to find the area of high field values before running a detailed measurement around the hot spot. Before starting the area scan a grid spacing of 15 mm x 15 mm is set. During the scan the distance of the probe to the phantom remains unchanged. After finishing area scan, the field maxima within a range of 2 dB will be ascertained.

#### Zoom Scan

After the maximum interpolated values were calculated between the points in the cube, the SAR was averaged over the spatial volume (1g or 10g) using a 3D-Spline interpolation algorithm. The 3D-spline is composed of three one-dimensional splines with the “Not a knot” condition (in x, y, and z directions). The volume was then integrated with the trapezoidal algorithm.

#### Spatial Peak Detection

The procedure for spatial peak SAR evaluation has been implemented and can determine values of masses of 1g and 10g, as well as for user-specific masses. The DASY5 system allows evaluations that combine measured data and robot positions, such as:

- maximum search
- extrapolation
- boundary correction
- peak search for averaged SAR

During a maximum search, global and local maxima searches are automatically performed in 2-D after each Area Scan measurement with at least 6 measurement points. It is based on the evaluation of the local SAR gradient calculated by the Quadratic Shepard’s method. The algorithm will find the global maximum and all local maxima within -2 dB of the global maxima for all SAR distributions.

Extrapolation routines are used to obtain SAR values between the lowest measurement points and the inner phantom surface. The extrapolation distance is determined by the surface detection distance and the probe sensor offset. Several measurements at different distances are necessary for the extrapolation. Extrapolation routines require at least 10 measurement points in 3-D space.

They are used in the Zoom Scan to obtain SAR values between the lowest measurement points and the inner phantom surface. The routine uses the modified Quadratic Shepard’s method for extrapolation.

A Z-axis scan measures the total SAR value at the x-and y-position of the maximum SAR value found during the cube scan. The probe is moved away in z-direction from the bottom of the SAM phantom in 5mm steps.

**Table 1: Area and Zoom Scan Resolutions per FCC KDB Publication 865664 D01v04**

		$\leq 3$ GHz	$> 3$ GHz	
Maximum distance from closest measurement point (geometric center of probe sensors) to phantom surface		5 mm $\pm$ 1 mm	$\frac{1}{2} \cdot \delta \cdot \ln(2)$ mm $\pm$ 0.5 mm	
Maximum probe angle from probe axis to phantom surface normal at the measurement location		$30^\circ \pm 1^\circ$	$20^\circ \pm 1^\circ$	
Maximum area scan spatial resolution: $\Delta x_{Area}$ , $\Delta y_{Area}$		$\leq 2$ GHz: $\leq 15$ mm 2 – 3 GHz: $\leq 12$ mm	3 – 4 GHz: $\leq 12$ mm 4 – 6 GHz: $\leq 10$ mm	
		When the x or y dimension of the test device, in the measurement plane orientation, is smaller than the above, the measurement resolution must be $\leq$ the corresponding x or y dimension of the test device with at least one measurement point on the test device.		
Maximum zoom scan spatial resolution: $\Delta x_{Zoom}$ , $\Delta y_{Zoom}$		$\leq 2$ GHz: $\leq 8$ mm 2 – 3 GHz: $\leq 5$ mm*	3 – 4 GHz: $\leq 5$ mm* 4 – 6 GHz: $\leq 4$ mm*	
Maximum zoom scan spatial resolution, normal to phantom surface	uniform grid: $\Delta z_{Zoom}(n)$	$\leq 5$ mm	3 – 4 GHz: $\leq 4$ mm 4 – 5 GHz: $\leq 3$ mm 5 – 6 GHz: $\leq 2$ mm	
	graded grid	$\Delta z_{Zoom}(1)$ : between 1 <sup>st</sup> two points closest to phantom surface	$\leq 4$ mm	3 – 4 GHz: $\leq 3$ mm 4 – 5 GHz: $\leq 2.5$ mm 5 – 6 GHz: $\leq 2$ mm
		$\Delta z_{Zoom}(n>1)$ : between subsequent points	$\leq 1.5 \cdot \Delta z_{Zoom}(n-1)$ mm	
Minimum zoom scan volume	x, y, z	$\geq 30$ mm	3 – 4 GHz: $\geq 28$ mm 4 – 5 GHz: $\geq 25$ mm 5 – 6 GHz: $\geq 22$ mm	
<p>Note: <math>\delta</math> is the penetration depth of a plane-wave at normal incidence to the tissue medium; see IEEE Std 1528-2013 for details.</p> <p>* When zoom scan is required and the <i>reported</i> SAR from the <i>area scan based 1-g SAR estimation</i> procedures of KDB Publication 447498 is <math>\leq 1.4</math> W/kg, <math>\leq 8</math> mm, <math>\leq 7</math> mm and <math>\leq 5</math> mm zoom scan resolution may be applied, respectively, for 2 GHz to 3 GHz, 3 GHz to 4 GHz and 4 GHz to 6 GHz.</p>				

## 7.2. Data Storage and Evaluation

### Data Storage

The DASY5 software stores the acquired data from the data acquisition electronics as raw data (in microvolt readings from the probe sensors),s together with all necessary software parameters for the data evaluation (probe calibration data, liquid parameters and device frequency and modulation data) in measurement files with the extension “.DA4”. The software evaluates the desired unit and format for output each time the data is visualized or exported. This allows verification of the complete software setup even after the measurement and allows correction of incorrect parameter settings. For example, if a measurement has been performed with a wrong crest factor parameter in the device setup, the parameter can be corrected afterwards and the data can be re-evaluated.

The measured data can be visualized or exported in different units or formats, depending on the selected probe type ([V/m], [A/m], [°C], [mW/g], [mW/cm<sup>2</sup>], [dBrel], etc.). Some of these units are not available in certain situations or show meaningless results, e.g., a SAR output in a lossless media will always be zero. Raw data can also be exported to perform the evaluation with other software packages.

### Data Evaluation

The SEMCAD software automatically executes the following procedures to calculate the field units from the microvolt readings at the probe connector. The parameters used in the evaluation are stored in the configuration modules of the software:

Probe parameters:	Sensitivity:	Normi, ai0, ai1, ai2
	Conversion factor:	ConvFi
	Diode compression point:	Dcpi
Device parameters:	Frequency:	f
	Crest factor:	cf
Media parameters:	Conductivity:	$\sigma$
	Density:	$\rho$

These parameters must be set correctly in the software. They can be found in the component documents or they can be imported into the software from the configuration files issued for the DASY5 components. In the direct measuring mode of the multimeter option, the parameters of the actual system setup are used. In the scan visualization and export modes, the parameters stored in the corresponding document files are used.

The first step of the evaluation is a linearization of the filtered input signal to account for the compression characteristics of the detector diode. The compensation depends on the input signal, the diode type and the DC-transmission factor from the diode to the evaluation electronics. If the exciting field is pulsed, the crest factor of the signal must be known to correctly compensate for peak power. The formula for each channel can be given as:

$$V_i = U_i + U_i^2 \cdot \frac{cf}{dcp_i}$$

Vi:	compensated signal of channel ( i = x, y, z )
Ui:	input signal of channel ( i = x, y, z )
cf:	crest factor of exciting field (DASY parameter)
dcp <sub>i</sub> :	diode compression point (DASY parameter)

From the compensated input signals the primary field data for each channel can be evaluated:

$$E - \text{fieldprobes} : \quad E_i = \sqrt{\frac{V_i}{Norm_i \cdot ConvF}}$$

$$H - \text{fieldprobes} : \quad H_i = \sqrt{V_i} \cdot \frac{a_{i0} + a_{i1}f + a_{i2}f^2}{f}$$

Vi:	compensated signal of channel ( i = x, y, z )
Normi:	sensor sensitivity of channel ( i = x, y, z ), [mV/(V/m) <sup>2</sup> ] for E-field Probes
ConvF:	sensitivity enhancement in solution
aij:	sensor sensitivity factors for H-field probes
f:	carrier frequency [GHz]
Ei:	electric field strength of channel i in V/m
Hi:	magnetic field strength of channel i in A/m



The RSS value of the field components gives the total field strength (Hermitian magnitude):

$$E_{tot} = \sqrt{E_x^2 + E_y^2 + E_z^2}$$

The primary field data are used to calculate the derived field units.

$$SAR = E_{tot}^2 \cdot \frac{\sigma}{\rho \cdot 1'000}$$

SAR: local specific absorption rate in mW/g  
Etot: total field strength in V/m  
 $\sigma$ : conductivity in [mho/m] or [Siemens/m]  
 $\rho$ : equivalent tissue density in g/cm<sup>3</sup>

Note that the density is normally set to 1 (or 1.06), to account for actual brain density rather than the density of the simulation liquid.

## 8. Position of the wireless device in relation to the phantom

### 8.1. Head Position

The wireless device define two imaginary lines on the handset, the vertical centreline and the horizontal line, for the handset in vertical orientation as shown in Figures 5a and 5b.

**The vertical centreline** passes through two points on the front side of the handset: the midpoint of the width  $W_t$  of the handset at the level of the acoustic output (point A in Figures 5a and 5b), and the midpoint of the width  $W_b$  of the bottom of the handset (point B).

**The horizontal line** is perpendicular to the vertical centre line and passes through the centre of the acoustic output (see Figures 5a and 5b). The two lines intersect at point A.

Note that for many handsets, point A coincides with the centre of the acoustic output. However, the acoustic output may be located elsewhere on the horizontal line. Also note that the vertical centreline is not necessarily parallel to the front face of the handset (see Figure 5b), especially for clam-shell handsets, handsets with flip cover pieces, and other irregularly shaped handsets.

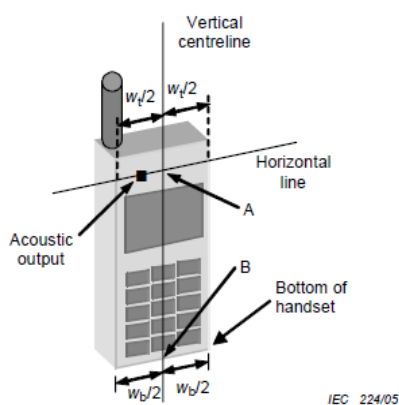

Figures 5a

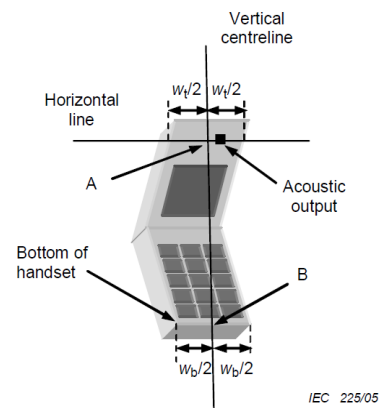

Figures 5b

- $W_t$  Width of the handset at the level of the acoustic
- $W_b$  Width of the bottom of the handset
- A Midpoint of the width  $w_t$  of the handset at the level of the acoustic output
- B Midpoint of the width  $w_b$  of the bottom of the handset

### Cheek position

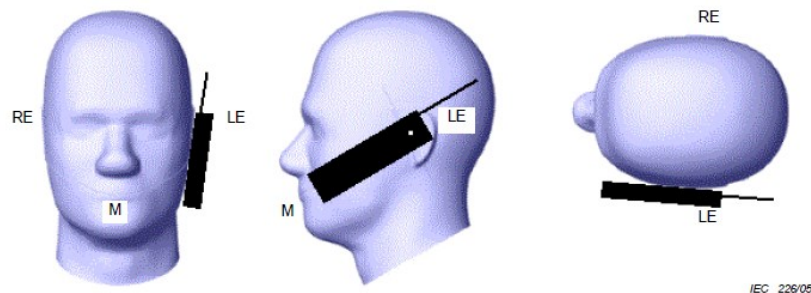

Picture 2 Cheek position of the wireless device on the left side of SAM

### Tilt position

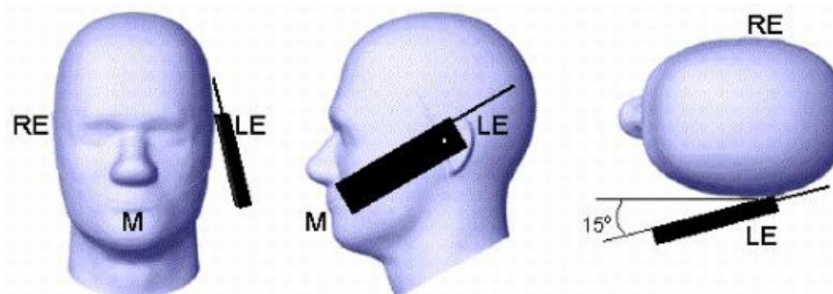

Picture 3 Tilt position of the wireless device on the left side of SAM

## 8.2. Body Position

Devices that support transmission while used with body-worn accessories must be tested for body-worn accessory SAR compliance, typically according to the smallest test separation distance required for the group of body-worn accessories with similar operating and exposure characteristics.

Devices that are designed to operate on the body of users using lanyards and straps or without requiring additional body-worn accessories must be tested for SAR compliance using a conservative minimum test separation distance  $\leq 5 \text{ mm}$  to support compliance

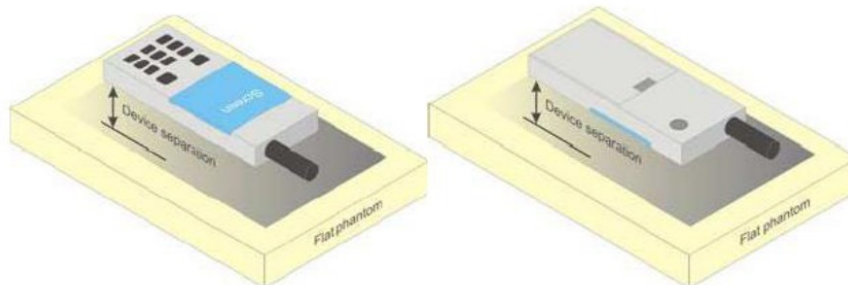

Picture 4 Test positions for body-worn devices

## 8.3. Hotspot Mode Exposure conditions

The hotspot mode and body-worn accessory SAR test configurations may overlap for handsets. When the same wireless mode transmission configurations for voice and data are required for SAR measurements, the more conservative configuration with a smaller separation distance should be tested for the overlapping SAR configurations. This typically applies to the back and front surfaces of a handset when SAR is required for both hotspot mode and body-worn accessory exposure conditions. Depending on the form factor and dimensions of a device, the test separation distance used for hotspot mode SAR measurement is either **10 mm** or that used in the body-worn accessory configuration, whichever is less for devices with dimension  $> 9 \text{ cm} \times 5 \text{ cm}$ . For smaller devices with dimensions  $\leq 9 \text{ cm} \times 5 \text{ cm}$  because of a greater potential for next to body use a test separation of  $\leq 5 \text{ mm}$  must be used.

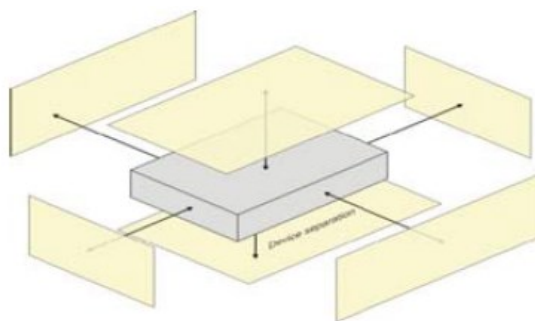

Picture 5 Test positions for Hotspot Mode

### 8.4. Front-of-face

A typical example of a front-of-face device is a two-way radio that is held at a distance from the face of the user when transmitting. In these cases the device under test shall be positioned at the distance to the phantom surface that corresponds to the intended use as specified by the manufacturer in the user instructions. If the intended use is not specified, a separation distance of 25 mm between the phantom surface and the device shall be used.

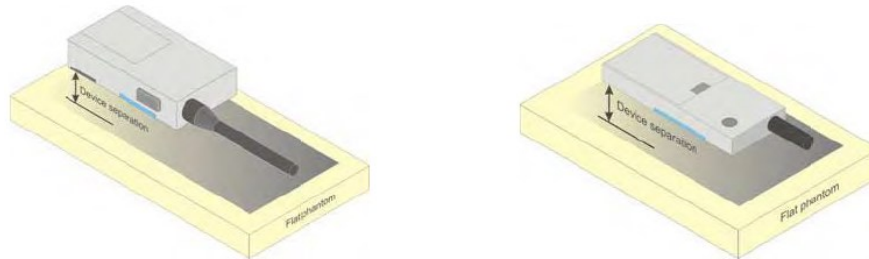

### 8.5. Body Position

A typical example of a body-worn device is a mobile phone, wireless enabled PDA or other battery operated wireless device with the ability to transmit while mounted on a person's body using a carry accessory approved by the wireless device manufacturer.

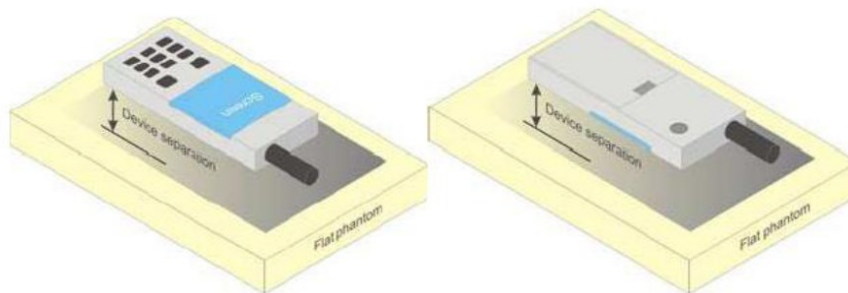

## 9. System Check

### 9.1. Tissue Dielectric Parameters

The liquid used for the frequency consisted of water, sugar, salt and Cellulose. The liquid has been previously proven to be suited for worst-case. The Table 1 and 2 shows the detail solution. It's satisfying the latest tissue dielectric parameters requirements proposed by the KDB865664 D01.

Table 1. Composition of the Tissue Equivalent Matter

Tissue dielectric parameters for head and body phantoms				
Target Frequency	Head		Body	
(MHz)	$\epsilon_r$	$\sigma$ (s/m)	$\epsilon_r$	$\sigma$ (s/m)
150	52.3	0.76	61.9	0.80
300	45.3	0.87	58.2	0.92
450	43.5	0.87	56.7	0.94
835	41.5	0.90	55.2	0.97
900	41.5	0.97	55.0	1.05
915	41.5	0.98	55.0	1.06
1450	40.5	1.20	54.0	1.30
1610	40.3	1.29	53.8	1.40
1800-2000	40.0	1.40	53.3	1.52
2450	39.2	1.80	52.7	1.95
2600	39.0	1.96	52.5	2.16
3000	38.5	2.40	52.0	2.73
5800	35.3	5.27	48.2	6.00

Table 2. Targets for tissue simulating liquid

Frequency (MHz)	Head Tissue		Body Tissue	
	$\epsilon_r$	$\sigma$ (S/m)	$\epsilon_r$	$\sigma$ (S/m)
150	52.3	0.76	61.9	0.80
300	45.3	0.87	58.2	0.92
<b>450</b>	<b>43.5</b>	<b>0.87</b>	<b>56.7</b>	<b>0.94</b>
835	41.5	0.90	55.2	0.97
900	41.5	0.97	55.0	1.05
915	41.5	0.98	55.0	1.06
1450	40.5	1.20	54.0	1.30
1610	40.3	1.29	53.8	1.40
1800-2000	40.0	1.40	53.3	1.52
2450	39.2	1.80	52.7	1.95
2600	39.0	1.96	52.5	2.16
3000	38.5	2.40	52.0	2.73
5800	35.3	5.27	48.2	6.00

**Check Result:**

<b>Dielectric performance of Head tissue simulating liquid</b>				
Frequency (MHz)	Description	Dielectric Parameters		Temp
		$\epsilon_r$	$\sigma$ (s/m)	°C
450	Recommended result ±5% window	43.50 41.32 - 45.67	0.87 0.83–0.91	/
	Measurement value 2017-06-16	43.64	0.89	21
835	Recommended result ±5% window	41.50 39.43 to 43.58	0.90 0.86 to 0.95	/
	Measurement value 2017-05-20	41.62	0.92	21
1750	Recommended result ±5% window	40.10 38.10- 42.11	1.37 1.30 - 1.44	/
	Measurement value 2017-05-26	40.73	1.41	21
1900	Recommended result ±5% window	40.0 38.00 to 42.00	1.40 1.33 to 1.47	/
	Measurement value 2017-06-03	40.05	1.42	21
2450	Recommended result ±5% window	39.2 37.24 to 41.16	1.80 1.71 to 1.89	/
	Measurement value 2017-06-09	39.11	1.79	21
2600	Recommended result ±5% window	39.0 37.05 to 40.95	1.96 1.86 to 2.06	/
	Measurement value 2017-06-12	38.83	1.93	21

Dielectric performance of Body tissue simulating liquid				
Frequency (MHz)	Description	Dielectric Parameters		Temp
		$\epsilon_r$	$\sigma$ (s/m)	°C
450	Recommended result ±5% window	56.7 53.87 - 59.53	0.94 0.89-0.98	/
	Measurement value 2017-06-20	56.50	0.95	21
835	Recommended result ±5% window	55.2 52.44 to 57.96	0.97 0.92 to 1.02	/
	Measurement value 2017-05-24	55.15	0.96	21
1750	Recommended result ±5% window	53.4 50.73-56.07	1.49 1.42 - 1.56	/
	Measurement value 2017-06-01	53.52	1.44	21
1900	Recommended result ±5% window	53.3 50.64 to 55.97	1.52 1.44 to 1.60	/
	Measurement value 2017-06-06	53.12	1.53	21
2450	Recommended result ±5% window	52.7 50.07 to 55.34	1.95 1.85 to 2.05	/
	Measurement value 2017-06-10	52.52	1.94	21
2600	Recommended result ±5% window	52.5 49.88 to 55.13	2.16 2.05 to 2.27	/
	Measurement value 2017-06-14	51.12	2.14	21

### 9.2. SAR System Check

The purpose of the system check is to verify that the system operates within its specifications at the device test frequency. The system check is simple check of repeatability to make sure that the system works correctly at the time of the compliance test;

System check results have to be equal or near the values determined during dipole calibration with the relevant liquids and test system ( $\pm 10\%$ ).

System check is performed regularly on all frequency bands where tests are performed with the DASY5 system.

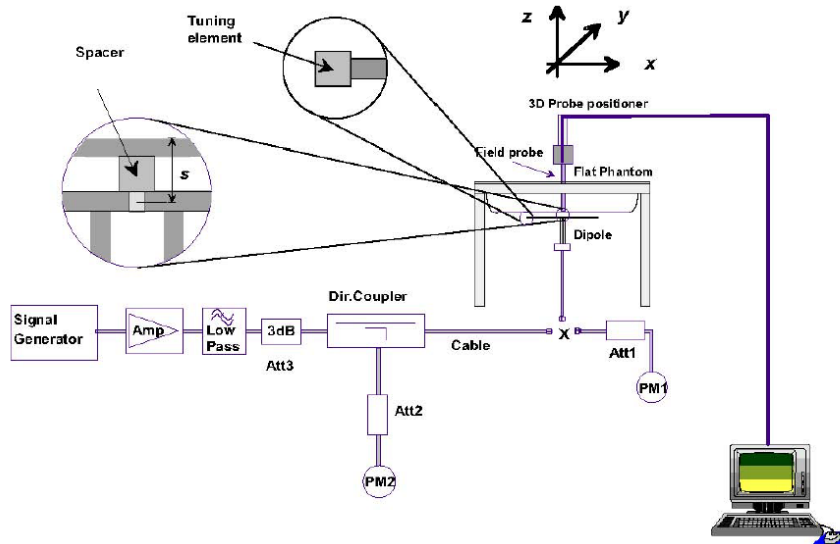

The output power on dipole port must be calibrated to 24dBm (250mW) before dipole is connected.

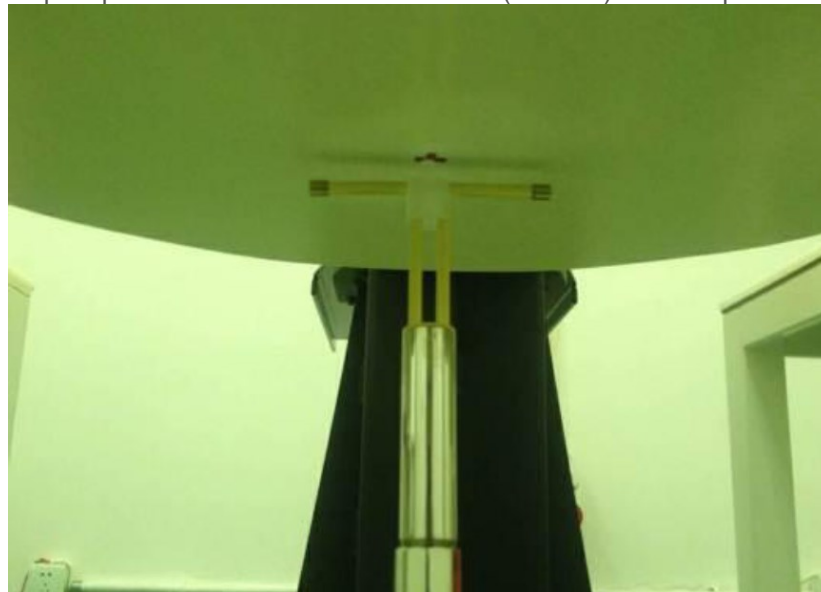

Photo of Dipole Setup



**Check Result:**

Head				
Frequency (MHz)	Description	SAR(W/kg)		Temp
		1g	10g	°C
450	Recommended result ±10% window	1.81 1.63 – 1.99	1.21 1.09 - 1.33	/
	Measurement value 2017-06-16	1.78	1.17	21
835	Recommended result ±5% window	2.41 2.29 - 2.53	1.57 1.49 - 1.65	/
	Measurement value 2017-05-20	2.34	1.52	21
1750	Recommended result ±5% window	9.20 8.28 - 10.12	4.97 4.48 - 5.46	/
	Measurement value 2017-05-26	9.62	4.98	21
1900	Recommended result ±5% window	10.10 9.60 - 10.61	5.34 5.07 - 5.61	/
	Measurement value 2017-06-03	9.72	5.16	21
2450	Recommended result ±5% window	13.1 11.79 - 14.41	6.17 5.56 - 6.78	/
	Measurement value 2017-06-09	12.40	5.80	21
2600	Recommended result ±5% window	13.7 13.02 - 14.39	6.07 5.77 - 6.37	/
	Measurement value 2017-06-12	14.20	6.29	21

Body				
Frequency (MHz)	Description	SAR(W/kg)		Temp
		1g	10g	°C
450	Recommended result ±10% window	1.74 1.57 – 1.91	1.16 1.04 - 1.27	/
	Measurement value 2017-06-20	1.69	1.12	21
835	Recommended result ±5% window	2.47 2.35 - 2.59	1.64 1.55 - 1.71	/
	Measurement value 2017-05-24	2.47	1.59	21
1750	Recommended result ±5% window	9.22 8.76 – 9.68	4.95 4.70 – 5.20	/
	Measurement value 2017-06-01	9.30	4.99	21
1900	Recommended result ±5% window	10.20 9.69 – 10.71	5.47 5.20 – 5.74	/
	Measurement value 2017-06-06	10.3	5.34	21
2450	Recommended result ±5% window	13.1 11.79 -14.41	6.11 5.50 -6.72	/
	Measurement value 2017-06-10	12.5	5.76	21
2600	Recommended result ±5% window	13.2 12.54 -13.86	5.87 5.58 -6.16	/
	Measurement value 2017-06-14	13.8	6.01	21

Note:

1. The graph results see follow.
2. Recommended Values used derive from the calibration certificate and 250 mW is used as feeding power to the calibrated dipole.

**System Performance Check at 450 MHz Head**

DUT: Dipole 450 MHz; Type: D450V3; Serial: 4d134

Date: 2017-06-16

Communication System: CW; Frequency: 450MHz; Duty Cycle: 1:1

Medium parameters used (interpolated):  $f = 450$  MHz;  $\sigma = 0.89$  S/m;  $\epsilon_r = 43.64$ ;  $\rho = 1000$  kg/m<sup>3</sup>

Phantom section: Flat Section

DASY5 Configuration:

Probe: ES3DV3 - SN3292; ConvF(7.12, 7.12, 7.12); Calibrated: 02/09/2016;

Sensor-Surface: 3mm (Mechanical Surface Detection)

Electronics: DAE4 Sn1315; Calibrated: 26/07/2016

Phantom: ELI v4.0; Type: QDOVA001BB;

Measurement SW: DASY52, Version 52.8 (2); SEMCAD X Version 14.6.5 (6469)

**Area Scan (61x171x1)**: Measurement grid:  $dx=15.00$  mm,  $dy=15.00$  mm

Maximum value of SAR (interpolated) = 2.58 mW/g

**Zoom Scan (7x7x7)/Cube 0**: Measurement grid:  $dx=5$ mm,  $dy=5$ mm,  $dz=5$ mm

Reference Value = 52.994 V/m; Power Drift = 0.082 dB

Peak SAR (extrapolated) = 3.542 W/kg

**SAR(1 g) = 1.78 mW/g****SAR(10 g) = 1.17 mW/g**

Maximum value of SAR (measured) = 2.59 mW/g

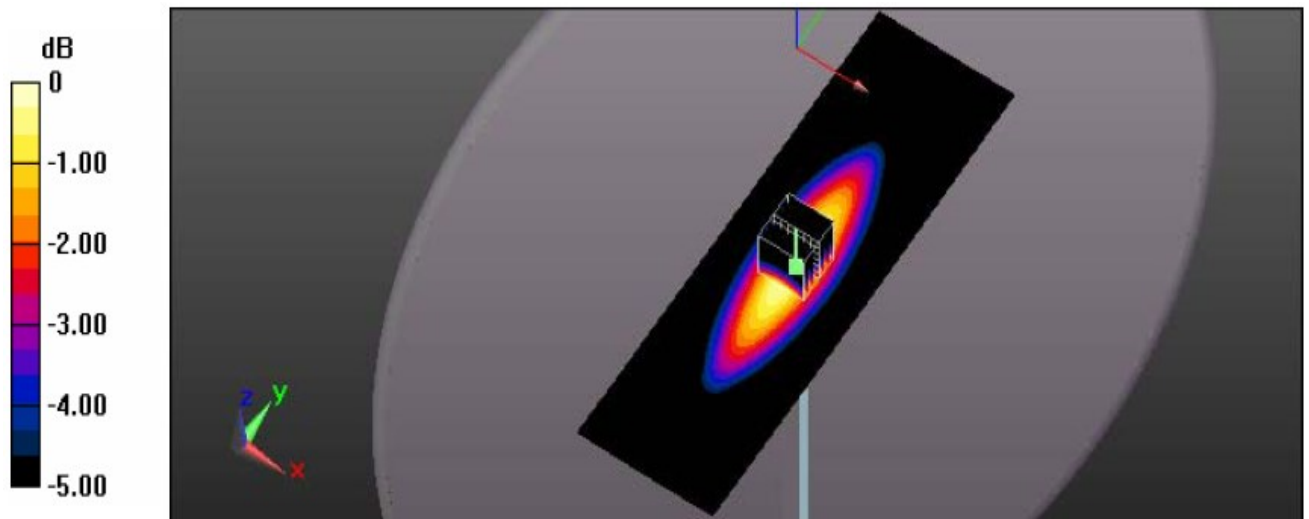

System Performance Check 450MHz 398mW

**System Performance Check at 450 MHz Body**

DUT: Dipole 450 MHz; Type: D450V3; Serial: 4d134

Date: 2017-06-20

Communication System: CW; Frequency: 450 MHz; Duty Cycle: 1:1

Medium parameters used (interpolated):  $f = 450$  MHz;  $\sigma = 0.95$  S/m;  $\epsilon_r = 56.50$ ;  $\rho = 1000$  kg/m<sup>3</sup>

Phantom section: Flat Section

DASY5 Configuration:

Probe: ES3DV3 - SN3292; ConvF(7.33, 7.33, 7.33); Calibrated: 02/09/2016;

Sensor-Surface: 3mm (Mechanical Surface Detection)

Electronics: DAE4 Sn1315; Calibrated: 26/07/2016

Measurement SW: DASY52, Version 52.8 (2); SEMCAD X Version 14.6.5 (6469)

**Area Scan (61x171x1):** Measurement grid: dx=15.00 mm, dy=15.00 mm

Maximum value of SAR (interpolated) = 2.15 mW/g

**Zoom Scan (7x7x7)/Cube 0:** Measurement grid: dx=5mm, dy=5mm, dz=5mm

Reference Value = 46.528 V/m; Power Drift = -0.02 dB

Peak SAR (extrapolated) = 3.262 W/kg

**SAR(1 g) = 1.69 mW/g SAR(10 g) = 1.12 mW/g**

Maximum value of SAR (measured) = 3.24 mW/g

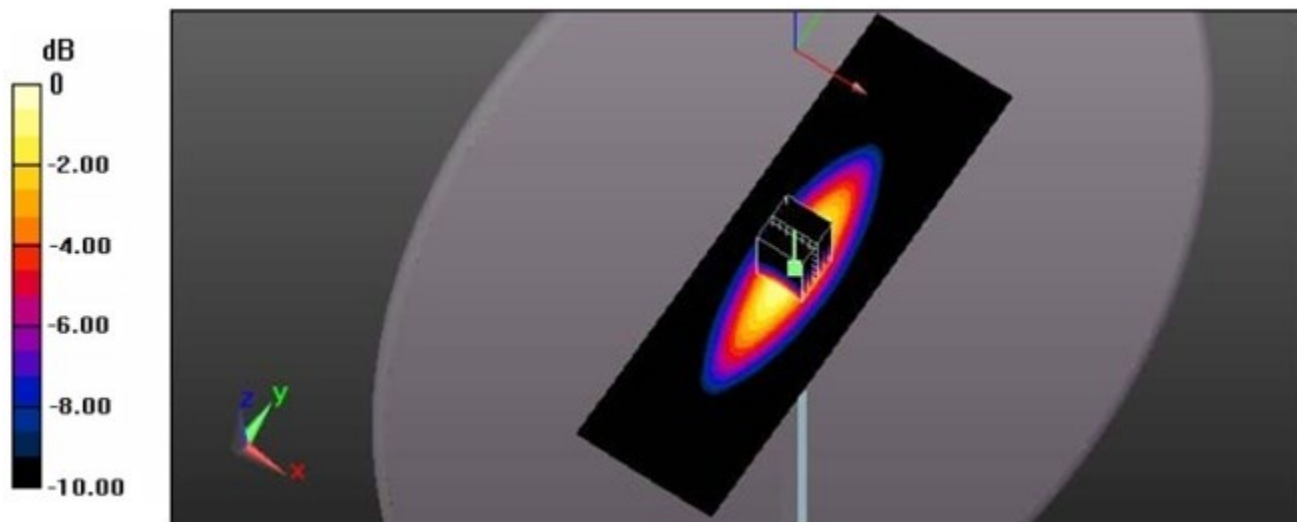

System Performance Check 450MHz Body 398mW

**System Performance Check at 835 MHz Head**

DUT: Dipole 835 MHz; Type: D835V2; Serial: 4d134

Date: 2017-05-20

Communication System: CW; Frequency: 835 MHz; Duty Cycle: 1:1

Medium parameters used (interpolated):  $f = 835$  MHz;  $\sigma = 0.92$  S/m;  $\epsilon_r = 41.62$ ;  $\rho = 1000$  kg/m<sup>3</sup>

Phantom section: Flat Section

**DASY5 Configuration:**

- Probe: ES3DV3 - SN3292; ConvF(6.53, 6.53, 6.53); Calibrated: 02/09/2016;
- Sensor-Surface: 4mm (Mechanical Surface Detection)
- Electronics: DAE4 Sn1315; Calibrated: 26/07/2016
- Phantom: SAM 1; Type: SAM;
- Measurement SW: DASY52, Version 52.8 (2); SEMCAD X Version 14.6.6 (6824)

**Area Scan (61x91x1): Measurement grid:** dx=15.00 mm, dy=15.00 mm

Maximum value of SAR (interpolated) = 2.834 mW/g

**Zoom Scan (5x5x7)/Cube 0:** Measurement grid: dx=5mm, dy=5mm, dz=5mm

Reference Value = 49.865 V/m; Power Drift = -0.01 dB

Peak SAR (extrapolated) = 3.286 W/kg

**SAR(1 g) = 2.34 mW/g; SAR(10 g) = 1.52 mW/g**

Maximum value of SAR (measured) = 2.825 mW/g

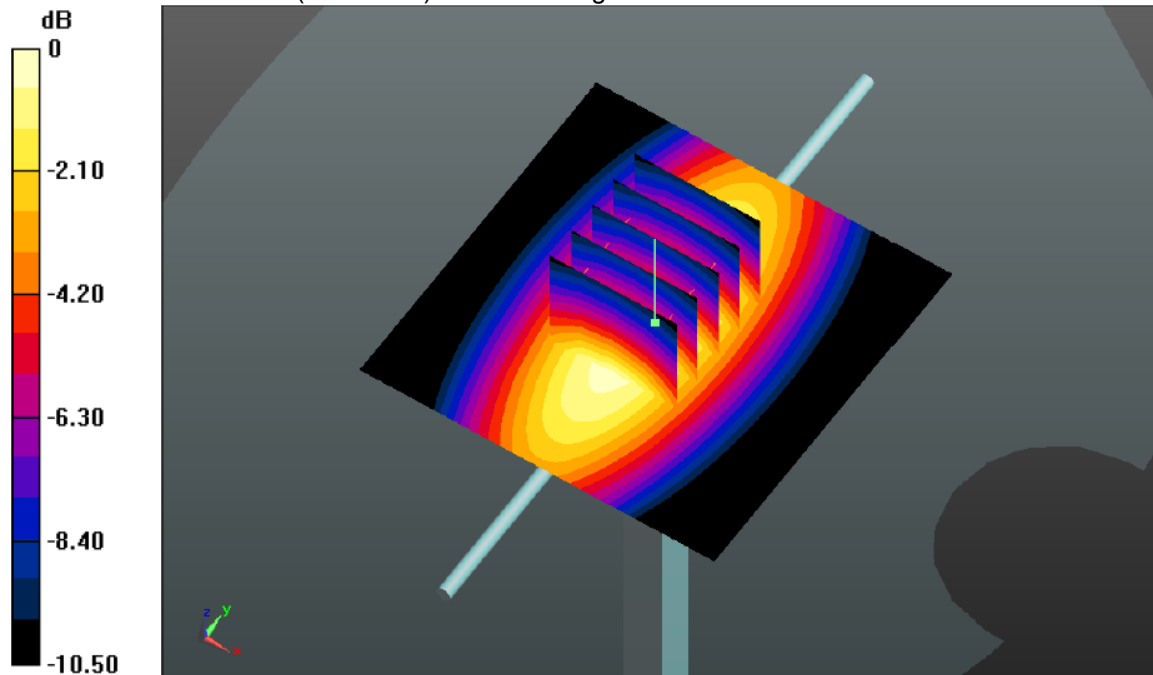

System Performance Check 835MHz Head 250mW

**System Performance Check at 835 MHz Body**

DUT: Dipole 835 MHz; Type: D835V2; Serial: 4d134

Date: 2017-05-24

Communication System: CW; Frequency: 835 MHz; Duty Cycle: 1:1

Medium parameters used (interpolated):  $f = 835$  MHz;  $\sigma = 0.96$  S/m;  $\epsilon_r = 55.15$ ;  $\rho = 1000$  kg/m<sup>3</sup>

Phantom section: Flat Section

**DASY5 Configuration:**

- Probe: ES3DV3 - SN3292; ConvF(6.27, 6.27, 6.27); Calibrated: 02/09/2016;
- Sensor-Surface: 4mm (Mechanical Surface Detection)
- Electronics: DAE4 Sn1315; Calibrated: 26/07/2016
- Phantom: SAM 1; Type: SAM;
- Measurement SW: DASY52, Version 52.8 (2); SEMCAD X Version 14.6.6 (6824)

**Area Scan (61x91x1): Measurement grid:** dx=15.00 mm, dy=15.00 mm

Maximum value of SAR (interpolated) = 2.888 mW/g

**Zoom Scan (5x5x7)/Cube 0:** Measurement grid: dx=8mm, dy=8mm, dz=5mm

Reference Value = 50.236 V/m; Power Drift = -0.02 dB

Peak SAR (extrapolated) = 3.339 W/kg

**SAR(1 g) = 2.47 mW/g; SAR(10 g) = 1.59 mW/g**

Maximum value of SAR (measured) = 2.871 mW/g

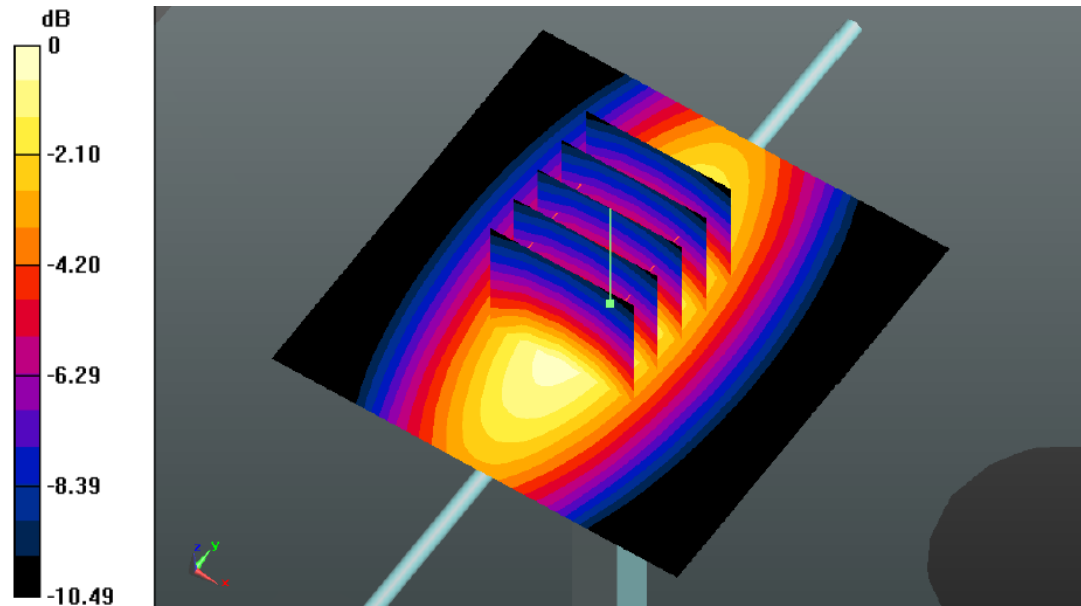

System Performance Check 835MHz Body 250mW

**System Performance Check at 1750 MHz Head**

DUT: Dipole 1750 MHz; Type: D1750V2; Serial: D1750V2

Date: 2017-05-26

Communication System: CW; Frequency: 1750 MHz; Duty Cycle: 1:1

Medium parameters used (interpolated):  $f = 1750$  MHz;  $\sigma = 1.41$  S/m;  $\epsilon_r = 40.73$ ;  $\rho = 1000$  kg/m<sup>3</sup>

Phantom section: Flat Section

DASY5 Configuration:

Probe: ES3DV3 - SN3292; ConvF(5.54,5.54,5.54); Calibrated: 02/09/2016;

Sensor-Surface: 3mm (Mechanical Surface Detection)

Electronics: DAE4 Sn1315; Calibrated: 26/07/2016

Phantom: SAM 1; Type: SAM;

Measurement SW: DASY52, Version 52.8 (1); SEMCAD X Version 14.6.5 (6469)

**Area Scan** (61x91x1): Measurement grid: dx=15.00 mm, dy=15.00 mm

Maximum value of SAR (interpolated) = 12.6 W/kg

**Zoom Scan** (7x7x5)/Cube 0: Measurement grid: dx=5mm, dy=5mm, dz=5mm

Reference Value = 99.561 V/m; Power Drift = -0.03 dB

Peak SAR (extrapolated) = 16.828 mW/g

**SAR(1 g) = 9.62 mW/g; SAR(10 g) = 4.98 mW/g**

Maximum value of SAR (measured) = 13.0 W/kg

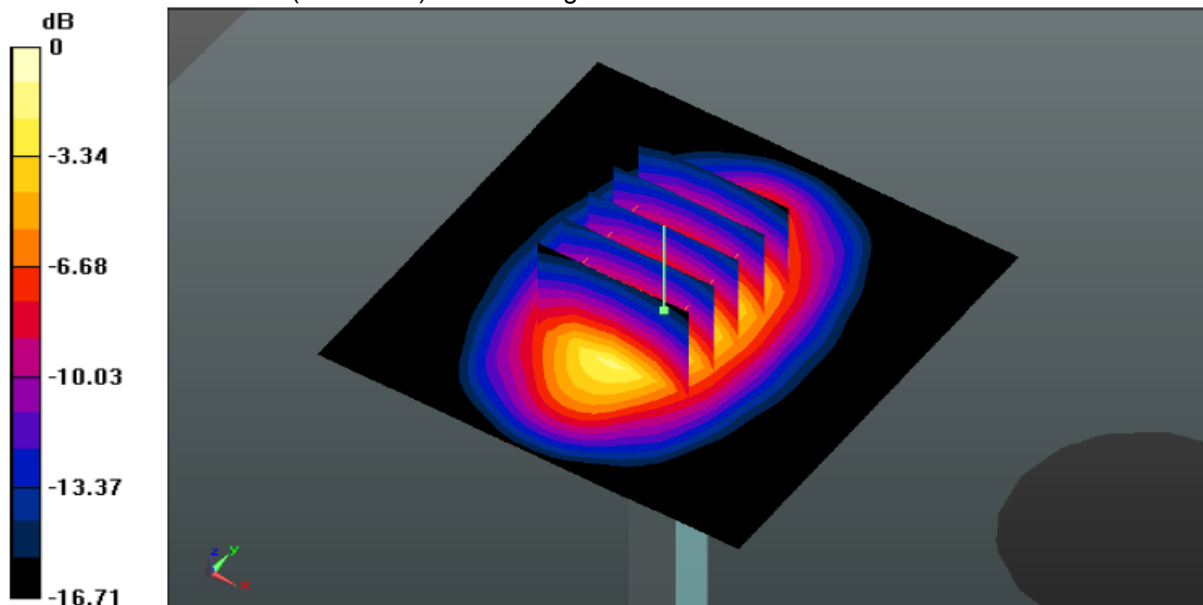

System Performance Check 1750MHz 250mW

**System Performance Check at 1750 MHz Body**

DUT: Dipole 1750 MHz; Type: D1750V2; Serial: D1750V2

Date: 2017-06-01

Communication System: CW; Frequency: 1750 MHz; Duty Cycle: 1:1

Medium parameters used (interpolated):  $f = 1750$  MHz;  $\sigma = 1.44$  S/m;  $\epsilon_r = 53.52$ ;  $\rho = 1000$  kg/m<sup>3</sup>

Phantom section: Flat Section

DASY5 Configuration:

Probe: ES3DV3 - SN3292; ConvF(5.28,5.28,5.28); Calibrated: 02/09/2016;

Sensor-Surface: 3mm (Mechanical Surface Detection)

Electronics: DAE4 Sn1315; Calibrated: 26/07/2016

Phantom: SAM 1; Type: SAM;

Measurement SW: DASY52, Version 52.8 (1); SEMCAD X Version 14.6.5 (6469)

**AreaScan(61x61x1): Measurement** grid: dx=15mm,dy=15mm

Maximum value of SAR(interpolated)=13.354mW/g

**ZoomScan(5x5x7)/Cube0:** Measurement grid:dx=8mm,dy=8mm,dz=5mm

Reference Value=87.582V/m; Power Drift=-0.06dB

Peak SAR (extrapolated) = 16.752 W/kg

**SAR(1 g) = 9.30 mW/g; SAR(10 g) = 4.99 mW/g**

Maximum value of SAR (measured) = 13.273 mW/g

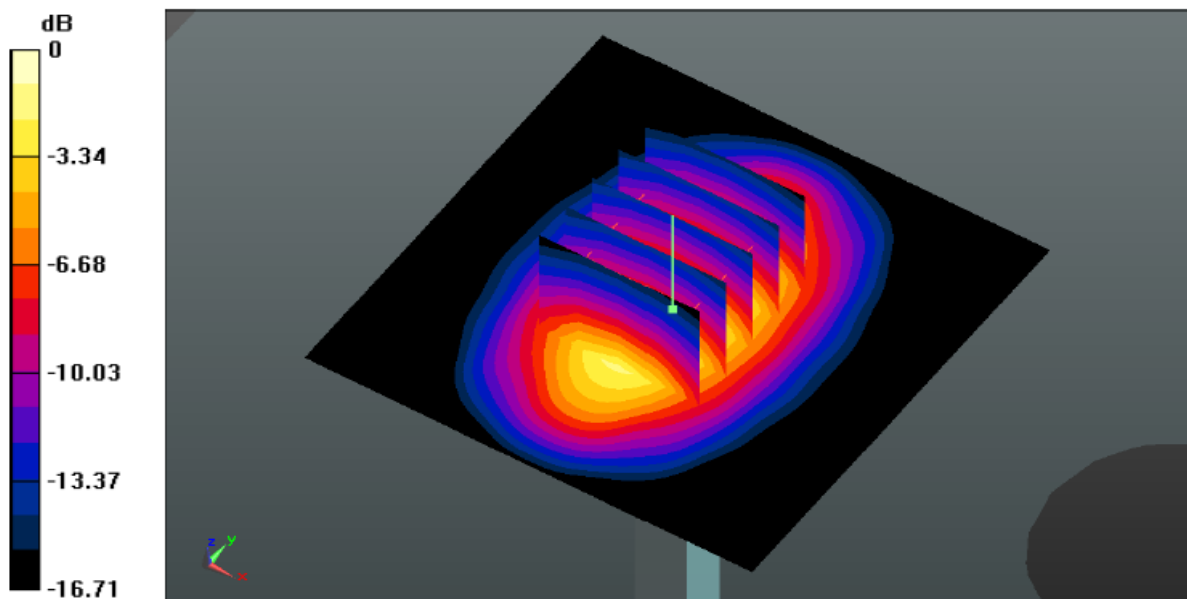

System Performance Check 1750MHz 250mW



**System Performance Check at 1900 MHz Head**

DUT: Dipole 1900 MHz; Type: D1900V2; Serial: 5d150

Date: 2017-06-03

Communication System: CW; Frequency: 1900 MHz; Duty Cycle: 1:1

Medium parameters used (interpolated):  $f = 1900$  MHz;  $\sigma = 1.42$  S/m;  $\epsilon_r = 40.05$ ;  $\rho = 1000$  kg/m<sup>3</sup>

Phantom section: Flat Section

**DASY5 Configuration:**

Probe: ES3DV3 - SN3292; ConvF(5.26,5.26,5.26); Calibrated: 02/09/2016;

Sensor-Surface: 3mm (Mechanical Surface Detection)

Electronics: DAE4 Sn1315; Calibrated: 26/07/2016

Phantom: SAM 1; Type: SAM;

Measurement SW: DASY52, Version 52.8 (1); SEMCAD X Version 14.6.5 (6469)

**Area Scan (61x91x1): Measurement grid:** dx=15.00 mm, dy=15.00 mm

Maximum value of SAR (interpolated) = 10.61 W/kg

**Zoom Scan (7x7x7)/Cube 0:** Measurement grid: dx=5mm, dy=5mm, dz=5mm

Reference Value = 94.79 V/m; Power Drift = -0.06 dB

Peak SAR (extrapolated) = 12.34 W/kg

**SAR(1 g) = 9.72 W/kg; SAR(10 g) = 5.16 W/kg**

Maximum value of SAR (measured) = 12.44 W/kg

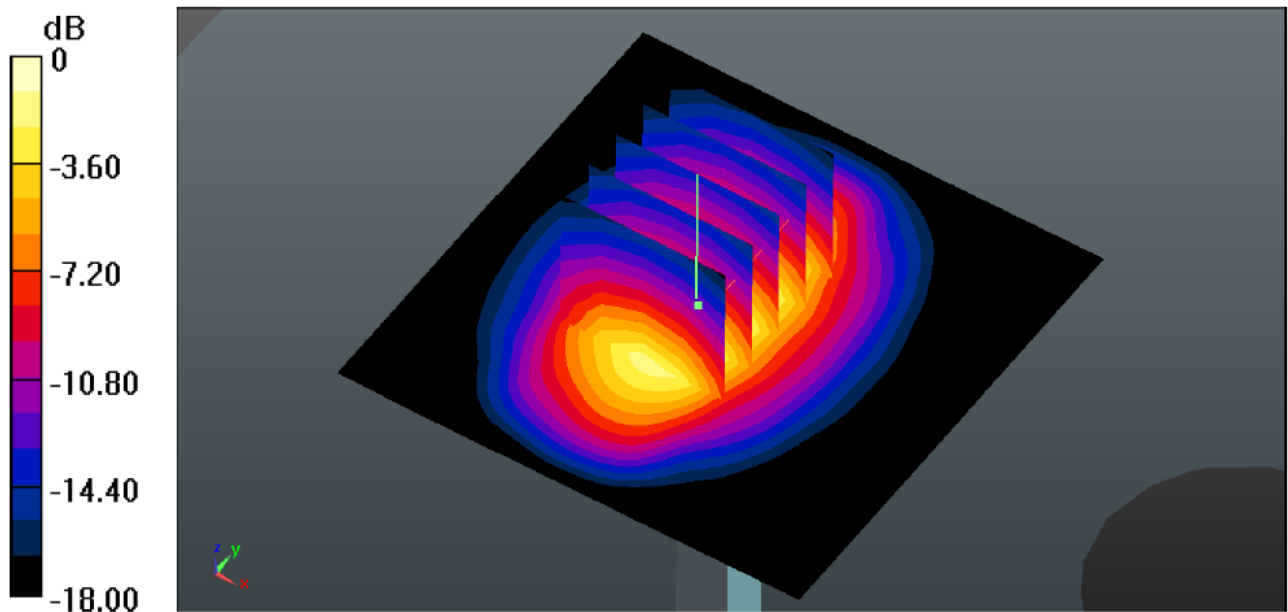

System Performance Check 1900MHz Head 250mW

**System Performance Check at 1900 MHz Body**

DUT: Dipole 1900 MHz; Type: D1900V2; Serial: 5d150

Date: 2017-06-06

Communication System: CW; Frequency: 1900 MHz; Duty Cycle: 1:1

Medium parameters used (interpolated):  $f = 1900$  MHz;  $\sigma = 1.53$  S/m;  $\epsilon_r = 53.12$ ;  $\rho = 1000$  kg/m<sup>3</sup>

Phantom section: Flat Section

**DASY5 Configuration:**

Probe: ES3DV3 - SN3292; ConvF(5.05,5.05,5.05); Calibrated: 02/09/2016;

Sensor-Surface: 3mm (Mechanical Surface Detection)

Electronics: DAE4 Sn1315; Calibrated: 26/07/2016

Phantom: SAM 1; Type: SAM;

Measurement SW: DASY52, Version 52.8 (1); SEMCAD X Version 14.6.5 (6469)

**Area Scan (61x91x1): Measurement grid:** dx=15.00 mm, dy=15.00 mm

Maximum value of SAR (interpolated) = 15.187 mW/g

**Zoom Scan (5x5x7)/Cube 0:** Measurement grid: dx=8mm, dy=8mm, dz=5mm

Reference Value = 87.679 V/m; Power Drift = -0.14 dB

Peak SAR (extrapolated) = 19.027 W/kg

**SAR(1 g) = 10.3 mW/g; SAR(10 g) = 5.34 mW/g**

Maximum value of SAR (measured) = 15.09 mW/g

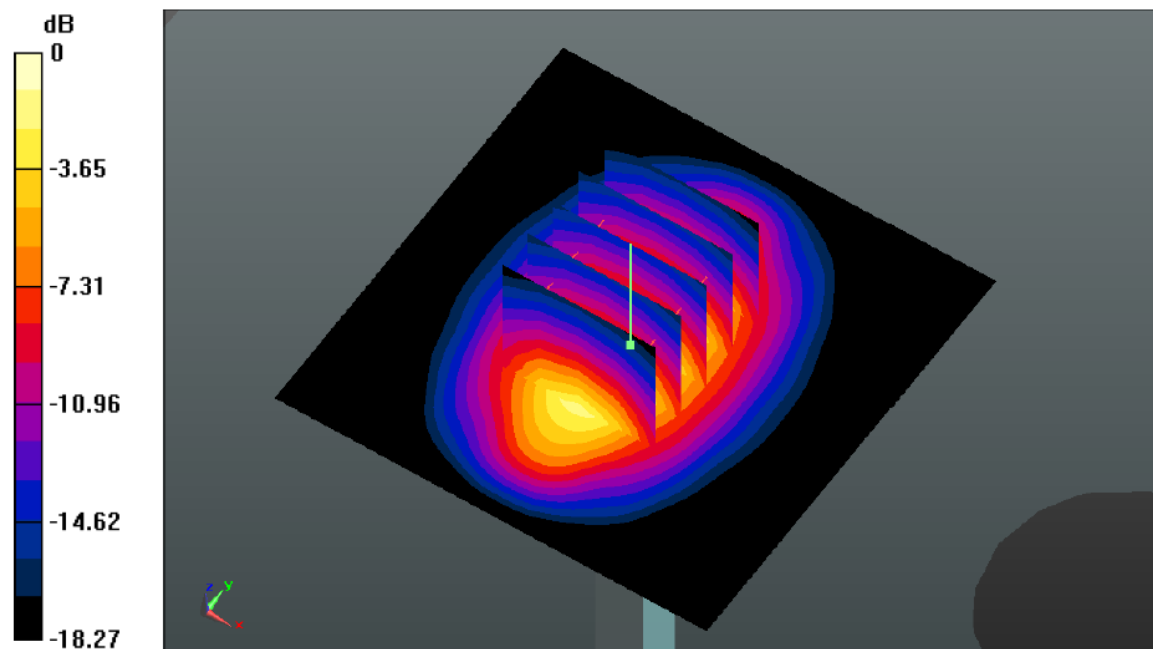

System Performance Check 1900MHz Body250mW

**System Performance Check at 2450 MHz Head**

DUT: Dipole 2450 MHz; Type: D2450V2; Serial: 884

Date: 2017-06-09

Communication System: CW; Frequency: 2450 MHz; Duty Cycle: 1:1

Medium parameters used (interpolated):  $f = 2450$  MHz;  $\sigma = 1.79$ S/m;  $\epsilon_r = 39.11$ ;  $\rho = 1000$  kg/m<sup>3</sup>

Phantom section: Flat Section

**DASY5 Configuration:**

Probe: ES3DV3 - SN3292; ConvF(4.97,4.97,4.97); Calibrated: 02/09/2016;

Sensor-Surface: 3mm (Mechanical Surface Detection)

Electronics: DAE4 Sn1315; Calibrated: 26/07/2016

Phantom: SAM 1; Type: SAM;

Measurement SW: DASY52, Version 52.8 (1); SEMCAD X Version 14.6.5 (6469)

**Area Scan (61x91x1): Measurement grid:** dx=10.00 mm, dy=10.00 mm

Maximum value of SAR (interpolated) = 19.313 mW/g

**Zoom Scan (7x7x7)/Cube 0:** Measurement grid: dx=5mm, dy=5mm, dz=5mm

Reference Value = 84.314 V/m; Power Drift = 0.02 dB

Peak SAR (extrapolated) = 25.703 W/kg

**SAR(1 g) = 12.4 mW/g; SAR(10 g) = 5.8 mW/g**

Maximum value of SAR (measured) = 18.871 mW/g

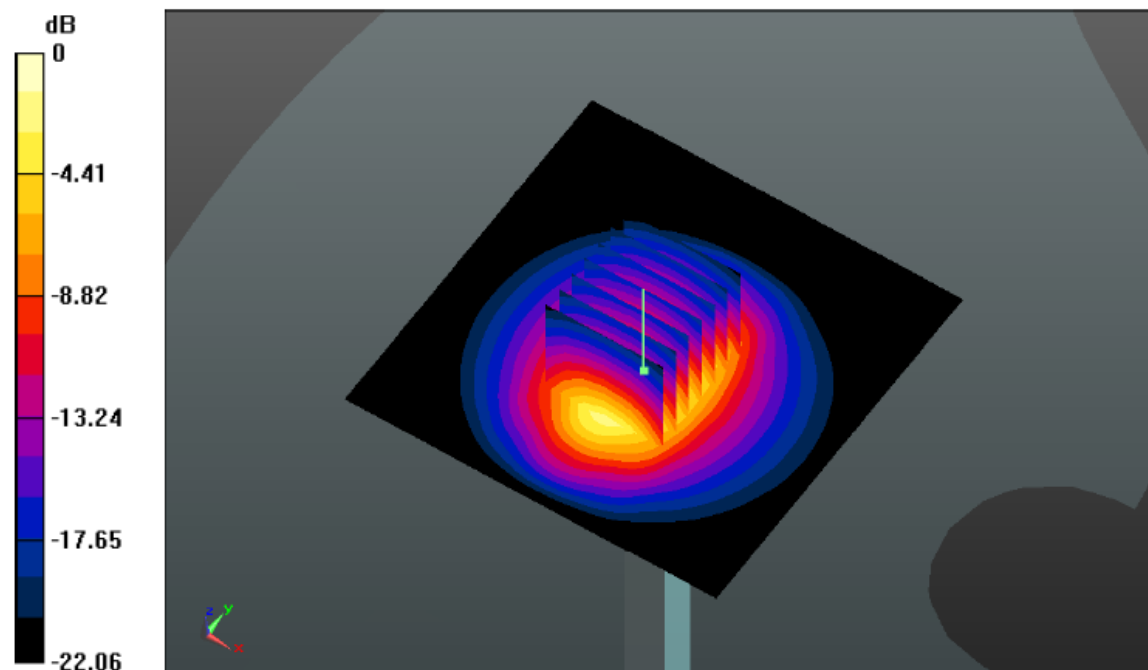

System Performance Check 2450MHz Head250mW

**System Performance Check at 2450 MHz Body**

Date: 2017-06-10

DUT: Dipole 2450 MHz; Type: D2450V2; Serial: 884

Communication System: CW; Frequency: 2450 MHz; Duty Cycle: 1:1

Medium parameters used (interpolated):  $f = 2450$  MHz;  $\sigma = 1.94$ S/m;  $\epsilon_r = 52.52$ ;  $\rho = 1000$  kg/m<sup>3</sup>

Phantom section: Flat Section

**DASY5 Configuration:**

Probe: ES3DV3 - SN3292; ConvF(4.70,4.70,4.70); Calibrated: 02/09/2016;

Sensor-Surface: 3mm (Mechanical Surface Detection)

Electronics: DAE4 Sn1315; Calibrated: 26/07/2016

Phantom: SAM 1; Type: SAM;

Measurement SW: DASY52, Version 52.8 (1); SEMCAD X Version 14.6.5 (6469)

**Area Scan (61x91x1): Measurement grid:** dx=10.00 mm, dy=10.00 mm

Maximum value of SAR (interpolated) = 19.266 mW/g

**Zoom Scan (7x7x7)/Cube 0:** Measurement grid: dx=5mm, dy=5mm, dz=5mm

Reference Value = 84.170 V/m; Power Drift = 0.03 dB

Peak SAR (extrapolated) = 26.174 W/kg

**SAR(1 g) = 12.5 mW/g; SAR(10 g) = 5.76 mW/g**

Maximum value of SAR (measured) = 19.27mW/g

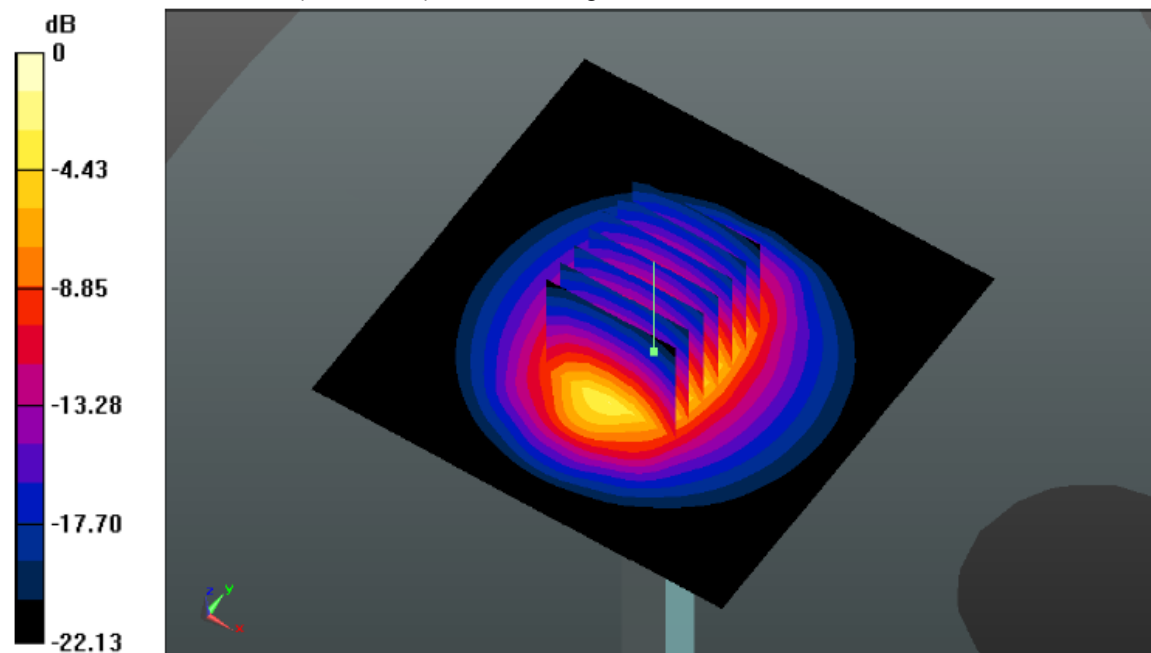

System Performance Check 2450MHz Body250mW

**System Performance Check at 2600 MHz Head**

DUT: Dipole 2600 MHz; Type: D2600V2; Serial: 1120

Date: 2017-06-12

Communication System: CW; Frequency: 2600 MHz; Duty Cycle: 1:1

Medium parameters used (interpolated):  $f = 2600$  MHz;  $\sigma = 1.93$  S/m;  $\epsilon_r = 38.83$ ;  $\rho = 1000$  kg/m<sup>3</sup>

Phantom section: Flat Section

**DASY5 Configuration:**

Probe: ES3DV3 - SN3292; ConvF(4.77,4.77,4.77); Calibrated: 02/09/2016;

Sensor-Surface: 3mm (Mechanical Surface Detection)

Electronics: DAE4 Sn1315; Calibrated: 26/07/2016

Phantom: SAM 1; Type: SAM;

Measurement SW: DASY52, Version 52.8 (1); SEMCAD X Version 14.6.5 (6469)

**Area Scan (61x91x1): Measurement grid:** dx=10.00 mm, dy=10.00 mm

Maximum value of SAR (interpolated) = 22.8 mW/g

**Zoom Scan (7x7x7)/Cube 0:** Measurement grid: dx=5mm, dy=5mm, dz=5mm

Reference Value = 110.2 V/m; Power Drift = 0.09 dB

Peak SAR (extrapolated) = 33.1 W/kg

**SAR(1 g) = 14.2 W/kg; SAR(10 g) = 6.29 W/kg**

Maximum value of SAR (measured) = 25.6 W/kg

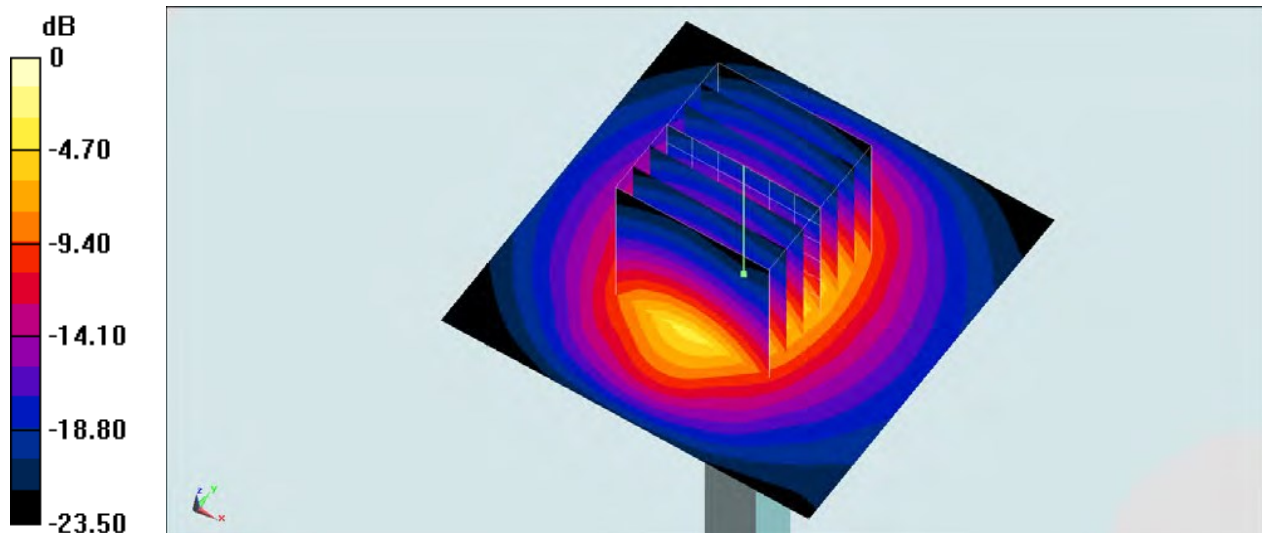

System Performance Check 2600MHz Head250mW

**System Performance Check at 2600 MHz Body**

Date: 2017-06-14

DUT: Dipole 2600 MHz; Type: D2600V2; Serial: 1120

Communication System: CW; Frequency: 2600 MHz; Duty Cycle: 1:1

Medium parameters used (interpolated):  $f = 2600$  MHz;  $\sigma = 2.14$  S/m;  $\epsilon_r = 51.12$ ;  $\rho = 1000$  kg/m<sup>3</sup>

Phantom section: Flat Section

**DASY5 Configuration:**

Probe: ES3DV3 - SN3292; ConvF(4.52,4.52,4.52); Calibrated: 02/09/2016;

Sensor-Surface: 3mm (Mechanical Surface Detection)

Electronics: DAE4 Sn1315; Calibrated: 26/07/2016

Phantom: SAM 1; Type: SAM;

Measurement SW: DASY52, Version 52.8 (1); SEMCAD X Version 14.6.5 (6469)

**Area Scan (61x91x1): Measurement grid:** dx=10.00 mm, dy=10.00 mm

Maximum value of SAR (interpolated) = 24.6 mW/g

**Zoom Scan (7x7x7)/Cube 0:** Measurement grid: dx=5mm, dy=5mm, dz=5mm

Reference Value = 108.4 V/m; Power Drift = -0.02 dB

Peak SAR (extrapolated) = 30.0 W/kg

**SAR(1 g) = 13.8 W/kg; SAR(10 g) = 6.01 W/kg**

Maximum value of SAR (measured) = 23.8 W/kg

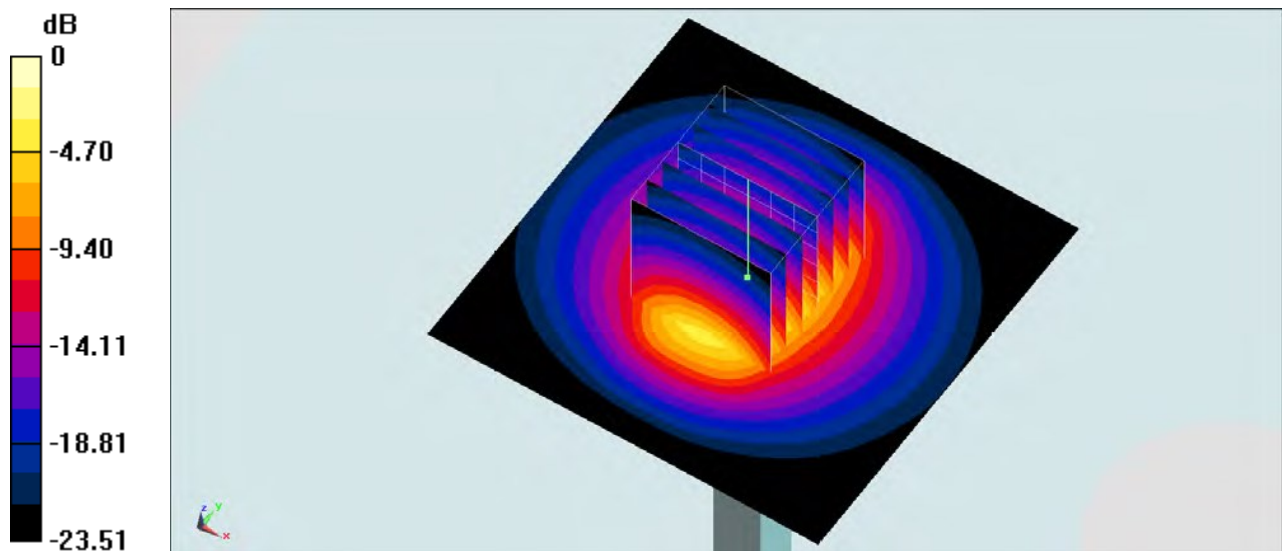

System Performance Check 2600MHz Body250mW

## 10. SAR Exposure Limits

SAR assessments have been made in line with the requirements of ANSI/IEEE C95.1-1992

Type Exposure	Limit (W/kg)	
	General Population / Uncontrolled Exposure Environment	Occupational / Controlled Exposure Environment
Spatial Average SAR (whole body)	0.08	0.4
Spatial Peak SAR (1g cube tissue for head and trunk)	1.60	8.0
Spatial Peak SAR (10g for limb)	4.0	20.0

Population/Uncontrolled Environments: are defined as locations where there is the exposure of individual who have no knowledge or control of their exposure.

Occupational/Controlled Environments: are defined as locations where there is exposure that may be incurred by people who are aware of the potential for exposure (i.e. as a result of employment or occupation).

## 11. Conducted Power Measurement Results

PTT					
Mode	Modulation	Operation Frequency Range	Channel	Frequency (MHz)	Conducted power (dBm)
TMO	$\pi/4$ DQPSK	450MHz~470MHz	CH1	450.05	33.10
			CH2	460.00	33.10
			CH3	469.95	33.15
DMO	$\pi/4$ DQPSK	450MHz~470MHz	CH1	450.05	33.10
			CH2	460.00	33.10
			CH3	469.95	33.00



**GSM Conducted Power**

1. Per KDB 447498 D01, the maximum output power channel is used for SAR testing and further SAR test reduction
2. Per KDB 941225 D01, considering the possibility of e.g. 3rd party VoIP operation for Head and Body-worn SAR test reduction for GSM and GPRS modes is determined by the source-base time-averaged output power including tune-up tolerance. The mode with highest specified time-averaged output power should be tested for SAR compliance in the applicable exposure conditions. For modes with the same specified maximum output power and tolerance, the higher number time-slot configuration should be tested. Therefore, the EUT was set in GPRS (4Tx slots) for GSM850 and GPRS (4Tx slots) for PCS1900.
3. Per KDB941225 D01, for hotspot SAR test reduction for GPRS modes is determined by the source-based time-averaged output power including tune-up tolerance, For modes with the same specified maximum output power and tolerance, the higher number time-slot configuration should be tested. Therefore, the EUT was set in GPRS (4Tx slots) for GSM850 and GPRS (4Tx slots) for PCS1900.

Mode: GSM850		Conducted Power (dBm)			Division Factors	Averager Power (dBm)		
		CH128	CH190	CH251		CH128	CH190	CH251
		824.2MHz	836.6MHz	848.8MHz		824.2MHz	836.6MHz	848.8MHz
GSM		33.64	33.61	33.51	-9.03	24.61	24.58	24.48
GPRS (GMSK)	1TXslot	33.61	33.60	33.49	-9.03	24.58	24.57	24.46
	2TXslots	31.01	31.03	30.81	-6.02	24.99	25.01	24.79
	3TXslots	29.22	29.30	29.11	-4.26	24.96	25.04	24.85
	4TXslots	28.02	28.11	27.91	-3.01	25.01	25.10	24.90
EGPRS (8PSK)	1TXslot	25.77	25.76	25.54	-9.03	16.74	16.73	16.51
	2TXslots	24.65	24.90	24.45	-6.02	18.63	18.88	18.43
	3TXslots	23.32	23.39	23.22	-4.26	19.06	19.13	18.96
	4TXslots	22.37	22.44	22.28	-3.01	19.36	19.43	19.27
Mode: PCS1900		Conducted Power (dBm)			Division Factors	Averager Power (dBm)		
		CH512	CH661	CH810		CH512	CH661	CH810
		1850.2MHz	1880.0MHz	1909.8MHz		1850.2MHz	1880.0MHz	1909.8MHz
GSM		29.94	29.81	29.44	-9.03	20.91	20.78	20.41
GPRS (GMSK)	1TXslot	29.91	29.80	29.43	-9.03	20.88	20.77	20.40
	2TXslots	27.60	27.52	27.18	-6.02	21.58	21.50	21.16
	3TXslots	26.01	25.99	25.61	-4.26	21.75	21.73	21.35
	4TXslots	24.94	24.93	24.52	-3.01	21.93	21.92	21.51
EGPRS (8PSK)	1TXslot	24.79	24.78	24.37	-9.03	15.76	15.75	15.34
	2TXslots	23.87	23.91	23.51	-6.02	17.85	17.89	17.49
	3TXslots	22.91	22.90	22.52	-4.26	18.65	18.64	18.26
	4TXslots	21.98	21.97	21.60	-3.01	18.97	18.96	18.59

Note:

## 1) Division Factors

To average the power, the division factor is as follows:

1TX-slot = 1 transmit time slot out of 8 time slots=&gt; conducted power divided by (8/1) =&gt; -9.03dB

2TX-slots = 2 transmit time slots out of 8 time slots=&gt; conducted power divided by (8/2) =&gt; -6.02dB

3TX-slots = 3 transmit time slots out of 8 time slots=&gt; conducted power divided by (8/3) =&gt; -4.26dB

4TX-slots = 4 transmit time slots out of 8 time slots=&gt; conducted power divided by (8/4) =&gt; -3.01dB

## LTE Conducted Power

### **General Note:**

1. CMW500 base station simulator was used to setup the connection with EUT; the frequency band, channel, bandwidth, RB allocation configuration, modulation type are set in the base station simulator to configure EUT transmitting at maximum power and at different configurations which are requested to be reported to FCC, for conducted power measurement and SAR testing.
2. Per KDB 941225 D05v02r03, when a properly configured base station simulator is used for the SAR and power measurements, spectrum plots for each RB allocation and offset configuration is not required.
3. Per KDB 941225 D05v02r03, start with the largest channel bandwidth and measure SAR for QPSK with 1 RB allocation, using the RB offset and required test channel combination with the highest maximum output power for RB offsets at the upper edge, middle and lower edge of each required test channel.
4. Per KDB 941225 D05v02r03, 50% RB allocation for QPSK SAR testing follows 1RB QPSK allocation procedure.
5. Per KDB 941225 D05v02r03, for QPSK with 100% RB allocation, SAR is not required when the highest maximum output power for 100 % RB allocation is less than the highest maximum output power in 50% and 1 RB allocations and the highest reported SAR for 1 RB and 50% RB allocation are  $\leq 0.8$  W/kg. Otherwise, SAR is measured for the highest output power channel; and if the reported SAR is  $> 1.45$  W/kg, the remaining required test channels must also be tested.
6. Per KDB 941225 D05v02r03, 16QAM output power for each RB allocation configuration is  $>$  not  $\frac{1}{2}$  dB higher than the same configuration in QPSK and the reported SAR for the QPSK configuration is  $\leq 1.45$  W/kg; Per KDB 941225D05v02r03, 16QAM SAR testing is not required.
7. Per KDB 941225 D05v02r03, smaller bandwidth output power for each RB allocation configuration is  $>$  not  $\frac{1}{2}$  dB higher than the same configuration in the largest supported bandwidth, and the reported SAR for the largest supported bandwidth is  $\leq 1.45$  W/kg; Per KDB 941225 D05v02r03, smaller bandwidth SAR testing is not required.

LTE-FDD Band 2				Actual output Power (dBm)		
Band-width	RBAallocation	RBOffset	Modulation	Low	Middle	High
1.4MHz	1RB	High	QPSK	21.63	21.72	21.78
			16QAM	21.37	21.39	21.41
		Middle	QPSK	21.55	21.69	21.60
			16QAM	21.35	21.33	21.20
		Low	QPSK	21.59	21.64	21.67
			16QAM	21.29	21.32	21.33
	3RB	High	QPSK	20.31	20.33	20.21
			16QAM	19.70	19.72	19.71
		Middle	QPSK	20.30	20.38	20.14
			16QAM	19.68	19.66	19.52
		Low	QPSK	20.27	20.26	20.11
			16QAM	19.62	19.65	19.63
	6RB	/	QPSK	20.24	20.00	19.66
			16QAM	19.41	19.46	19.35
3MHz	1RB	High	QPSK	21.70	21.71	21.74
			16QAM	21.44	21.37	21.38
		Middle	QPSK	21.61	21.67	21.56
			16QAM	21.41	21.31	21.17
		Low	QPSK	21.65	21.62	21.64
			16QAM	21.35	21.30	21.29
	8RB	High	QPSK	20.37	20.32	20.18
			16QAM	19.76	19.70	19.67
		Middle	QPSK	20.36	20.37	20.11
			16QAM	19.74	19.64	19.48
		Low	QPSK	20.33	20.24	20.08
			16QAM	19.68	19.63	19.60
	15RB	/	QPSK	20.30	19.98	19.63
			16QAM	19.47	19.45	19.32

5MHz	1RB	High	QPSK	21.65	21.75	21.71
			16QAM	21.39	21.42	21.34
		Middle	QPSK	21.57	21.72	21.52
			16QAM	21.37	21.36	21.13
		Low	QPSK	21.61	21.67	21.60
			16QAM	21.30	21.35	21.26
	12RB	High	QPSK	20.33	20.36	20.14
			16QAM	19.72	19.74	19.64
		Middle	QPSK	20.31	20.41	20.08
			16QAM	19.70	19.68	19.45
		Low	QPSK	20.29	20.28	20.05
			16QAM	19.64	19.68	19.56
	25RB		QPSK	20.26	20.03	19.60
			16QAM	19.43	19.49	19.29
10MHz	1RB	High	QPSK	21.63	21.78	21.69
			16QAM	21.37	21.44	21.33
		Middle	QPSK	21.54	21.75	21.51
			16QAM	21.34	21.38	21.12
		Low	QPSK	21.58	21.70	21.59
			16QAM	21.28	21.37	21.24
	25RB	High	QPSK	20.31	20.38	20.13
			16QAM	19.70	19.76	19.63
		Middle	QPSK	20.29	20.43	20.07
			16QAM	19.68	19.71	19.44
		Low	QPSK	20.26	20.31	20.03
			16QAM	19.62	19.70	19.55
	50RB	/	QPSK	20.24	20.05	19.58
			16QAM	19.41	19.51	19.28

15MHz	1RB	High	QPSK	21.67	21.75	21.72
			16QAM	21.41	21.42	21.35
		Middle	QPSK	21.59	21.72	21.53
			16QAM	21.39	21.36	21.14
		Low	QPSK	21.63	21.67	21.61
			16QAM	21.32	21.35	21.27
	36RB	High	QPSK	20.35	20.36	20.15
			16QAM	19.74	19.74	19.65
		Middle	QPSK	20.33	20.41	20.09
			16QAM	19.72	19.68	19.46
		Low	QPSK	20.31	20.28	20.06
			16QAM	19.66	19.67	19.57
	75RB	/	QPSK	20.28	20.02	19.61
			16QAM	19.45	19.49	19.30
20MHz	1RB	High	QPSK	21.72	21.82	21.79
			16QAM	21.16	21.24	21.20
		Middle	QPSK	21.63	21.79	21.61
			16QAM	21.14	21.17	20.99
		Low	QPSK	21.67	21.74	21.68
			16QAM	21.08	21.17	21.11
	50RB	High	QPSK	20.39	20.42	20.22
			16QAM	19.51	19.57	19.51
		Middle	QPSK	20.38	20.47	20.16
			16QAM	19.49	19.51	19.32
		Low	QPSK	20.35	20.35	20.12
			16QAM	19.43	19.51	19.43
	100RB	/	QPSK	20.32	20.09	19.67
			16QAM	19.22	19.32	19.16

LTE-FDD Band 4				Actual output Power (dBm)			
Band-width	RAllocation	RBoffset	Modulation	Low	Middle	High	
1.4MHz	1RB	High	QPSK	22.14	22.23	22.21	
			16QAM	21.87	21.89	21.84	
		Middle	QPSK	22.05	22.20	22.03	
			16QAM	21.85	21.83	21.63	
		Low	QPSK	22.09	22.15	22.11	
			16QAM	21.78	21.82	21.75	
	3RB	High	QPSK	20.79	20.81	20.62	
			16QAM	20.16	20.18	20.10	
		Middle	QPSK	20.77	20.86	20.55	
			16QAM	20.14	20.12	19.91	
		Low	QPSK	20.74	20.73	20.52	
			16QAM	20.08	20.11	20.02	
	6RB	/	QPSK	20.71	20.47	20.05	
			16QAM	19.87	19.92	19.74	
	3MHz	1RB	High	QPSK	22.21	22.21	22.18
				16QAM	21.94	21.87	21.80
			Middle	QPSK	22.12	22.18	21.99
				16QAM	21.91	21.81	21.59
Low			QPSK	22.16	22.13	22.07	
			16QAM	21.85	21.80	21.72	
8RB		High	QPSK	20.85	20.79	20.58	
			16QAM	20.22	20.16	20.07	
		Middle	QPSK	20.83	20.84	20.51	
			16QAM	20.20	20.10	19.87	
		Low	QPSK	20.81	20.71	20.48	
			16QAM	20.14	20.09	19.99	
15RB		/	QPSK	20.77	20.45	20.02	
			16QAM	19.92	19.90	19.71	

5MHz	1RB	High	QPSK	22.16	22.26	22.14
			16QAM	21.89	21.92	21.77
		Middle	QPSK	22.07	22.23	21.96
			16QAM	21.87	21.86	21.56
		Low	QPSK	22.11	22.18	22.03
			16QAM	21.80	21.85	21.68
	12RB	High	QPSK	20.81	20.83	20.55
			16QAM	20.18	20.20	20.04
		Middle	QPSK	20.79	20.89	20.48
			16QAM	20.16	20.14	19.84
		Low	QPSK	20.76	20.76	20.45
			16QAM	20.10	20.14	19.96
	25RB		QPSK	20.73	20.49	19.99
			16QAM	19.88	19.94	19.68
10MHz	1RB	High	QPSK	22.13	22.28	22.13
			16QAM	21.87	21.95	21.75
		Middle	QPSK	22.05	22.25	21.94
			16QAM	21.84	21.88	21.54
		Low	QPSK	22.09	22.20	22.02
			16QAM	21.78	21.87	21.67
	25RB	High	QPSK	20.78	20.86	20.53
			16QAM	20.16	20.22	20.02
		Middle	QPSK	20.76	20.91	20.47
			16QAM	20.14	20.17	19.83
		Low	QPSK	20.74	20.78	20.44
			16QAM	20.08	20.16	19.94
	50RB	/	QPSK	20.71	20.52	19.98
			16QAM	19.86	19.97	19.66

15MHz	1RB	High	QPSK	22.18	22.26	22.15
			16QAM	21.91	21.92	21.78
		Middle	QPSK	22.09	22.23	21.97
			16QAM	21.89	21.86	21.57
		Low	QPSK	22.13	22.17	22.04
			16QAM	21.82	21.85	21.69
	36RB	High	QPSK	20.83	20.83	20.56
			16QAM	20.20	20.20	20.05
		Middle	QPSK	20.81	20.88	20.49
			16QAM	20.18	20.14	19.85
		Low	QPSK	20.78	20.76	20.46
			16QAM	20.12	20.13	19.97
	75RB	/	QPSK	20.75	20.49	20.00
			16QAM	19.90	19.94	19.68
20MHz	1RB	High	QPSK	22.25	22.33	22.23
			16QAM	21.69	21.74	21.62
		Middle	QPSK	22.16	22.30	22.04
			16QAM	21.66	21.67	21.41
		Low	QPSK	22.20	22.25	22.12
			16QAM	21.60	21.66	21.53
	50RB	High	QPSK	20.89	20.90	20.63
			16QAM	19.99	20.03	19.89
		Middle	QPSK	20.87	20.95	20.56
			16QAM	19.97	19.97	19.70
		Low	QPSK	20.85	20.82	20.53
			16QAM	19.91	19.97	19.82
	100RB	/	QPSK	20.82	20.56	20.07
			16QAM	19.70	19.78	19.54



LTE-FDD Band 5				Actual output Power (dBm)		
Band-width	RBAallocation	RBOffset	Modulation	Low	Middle	High
1.4MHz	1RB	High	QPSK	22.22	22.18	22.28
			16QAM	21.95	21.84	21.90
		Middle	QPSK	22.13	22.15	22.09
			16QAM	21.92	21.78	21.69
		Low	QPSK	22.17	22.09	22.17
			16QAM	21.86	21.77	21.81
	3RB	High	QPSK	20.86	20.76	20.67
			16QAM	20.23	20.13	20.16
		Middle	QPSK	20.84	20.81	20.61
			16QAM	20.21	20.07	19.96
		Low	QPSK	20.82	20.68	20.57
			16QAM	20.15	20.06	20.08
	6RB	/	QPSK	20.79	20.42	20.11
			16QAM	19.94	19.87	19.80
3MHz	1RB	High	QPSK	22.28	22.16	22.24
			16QAM	22.01	21.82	21.87
		Middle	QPSK	22.19	22.13	22.05
			16QAM	21.99	21.76	21.65
		Low	QPSK	22.23	22.08	22.13
			16QAM	21.92	21.75	21.78
	8RB	High	QPSK	20.92	20.74	20.64
			16QAM	20.29	20.11	20.13
		Middle	QPSK	20.90	20.79	20.57
			16QAM	20.27	20.05	19.93
		Low	QPSK	20.88	20.66	20.54
			16QAM	20.21	20.04	20.05
	15RB	/	QPSK	20.85	20.40	20.08
			16QAM	19.99	19.85	19.76

5MHz	1RB	High	QPSK	22.23	22.20	22.20
			16QAM	21.97	21.87	21.83
		Middle	QPSK	22.15	22.17	22.02
			16QAM	21.94	21.80	21.62
		Low	QPSK	22.19	22.12	22.10
			16QAM	21.88	21.79	21.74
	12RB	High	QPSK	20.88	20.78	20.61
			16QAM	20.25	20.15	20.09
		Middle	QPSK	20.86	20.83	20.54
			16QAM	20.23	20.09	19.90
		Low	QPSK	20.83	20.71	20.51
			16QAM	20.17	20.09	20.01
25RB		QPSK	20.80	20.44	20.05	
		16QAM	19.95	19.89	19.73	
10MHz	1RB	High	QPSK	22.21	22.23	22.19
			16QAM	21.64	21.63	21.58
		Middle	QPSK	22.12	22.20	22.00
			16QAM	21.62	21.57	21.37
		Low	QPSK	22.16	22.15	22.08
			16QAM	21.55	21.56	21.50
	25RB	High	QPSK	20.85	20.81	20.59
			16QAM	19.95	19.94	19.87
		Middle	QPSK	20.84	20.86	20.53
			16QAM	19.93	19.88	19.67
		Low	QPSK	20.81	20.73	20.49
			16QAM	19.87	19.87	19.79
	50RB	/	QPSK	20.78	20.47	20.03
			16QAM	19.66	19.68	19.51

LTE-FDD Band 7				Actual output Power (dBm)		
Band-width	RAllocation	RBoffset	Modulation	Low	Middle	High
5MHz	1RB	High	QPSK	21.42	21.52	21.43
			16QAM	21.16	21.19	21.07
		Middle	QPSK	21.34	21.49	21.25
			16QAM	21.14	21.13	20.87
		Low	QPSK	21.38	21.44	21.33
			16QAM	21.08	21.12	20.99
	12RB	High	QPSK	20.11	20.14	19.89
			16QAM	19.51	19.53	19.40
		Middle	QPSK	20.10	20.19	19.83
			16QAM	19.49	19.48	19.21
		Low	QPSK	20.07	20.07	19.80
			16QAM	19.43	19.47	19.32
	25RB		QPSK	20.04	19.81	19.35
			16QAM	19.22	19.28	19.05
10MHz	1RB	High	QPSK	21.40	21.55	21.42
			16QAM	21.14	21.22	21.06
		Middle	QPSK	21.31	21.52	21.24
			16QAM	21.12	21.16	20.86
		Low	QPSK	21.35	21.47	21.32
			16QAM	21.05	21.15	20.98
	25RB	High	QPSK	20.09	20.17	19.88
			16QAM	19.49	19.55	19.38
		Middle	QPSK	20.07	20.22	19.81
			16QAM	19.47	19.50	19.19
		Low	QPSK	20.05	20.09	19.78
			16QAM	19.41	19.49	19.31
	50RB	/	QPSK	20.02	19.84	19.34
			16QAM	19.20	19.30	19.03

15MHz	1RB	High	QPSK	21.44	21.52	21.44
			16QAM	21.18	21.19	21.08
		Middle	QPSK	21.36	21.49	21.26
			16QAM	21.16	21.13	20.88
		Low	QPSK	21.40	21.44	21.34
			16QAM	21.10	21.12	21.00
	36RB	High	QPSK	20.13	20.14	19.90
			16QAM	19.53	19.53	19.40
		Middle	QPSK	20.11	20.19	19.84
			16QAM	19.51	19.47	19.22
		Low	QPSK	20.09	20.07	19.81
			16QAM	19.45	19.47	19.33
	75RB	/	QPSK	20.06	19.81	19.36
			16QAM	19.24	19.28	19.06
20MHz	1RB	High	QPSK	21.51	21.59	21.52
			16QAM	20.96	21.01	20.93
		Middle	QPSK	21.42	21.56	21.34
			16QAM	20.93	20.95	20.73
		Low	QPSK	21.46	21.51	21.42
			16QAM	20.87	20.94	20.85
	50RB	High	QPSK	20.20	20.21	19.97
			16QAM	19.32	19.36	19.27
		Middle	QPSK	20.18	20.26	19.91
			16QAM	19.30	19.31	19.08
		Low	QPSK	20.15	20.13	19.87
			16QAM	19.24	19.30	19.19
	100RB	/	QPSK	20.12	19.88	19.43
			16QAM	19.04	19.12	18.92

LTE-FDD Band 26				Actual output Power (dBm)			
Band-width	RAllocation	RBoffset	Modulation	Low	Middle	High	
1.4MHz	1RB	High	QPSK	22.63	22.73	22.71	
			16QAM	22.36	22.39	22.33	
		Middle	QPSK	22.54	22.70	22.52	
			16QAM	22.33	22.32	22.11	
		Low	QPSK	22.58	22.65	22.60	
			16QAM	22.27	22.31	22.24	
	3RB	High	QPSK	21.25	21.28	21.08	
			16QAM	20.61	20.63	20.55	
		Middle	QPSK	21.23	21.33	21.01	
			16QAM	20.59	20.57	20.35	
		Low	QPSK	21.20	21.20	20.98	
			16QAM	20.53	20.56	20.47	
	6RB	/	QPSK	21.17	20.93	20.51	
			16QAM	20.31	20.37	20.18	
	3MHz	1RB	High	QPSK	22.70	22.71	22.68
				16QAM	22.42	22.37	22.29
			Middle	QPSK	22.61	22.68	22.49
				16QAM	22.40	22.30	22.08
Low			QPSK	22.65	22.63	22.57	
			16QAM	22.33	22.29	22.21	
8RB		High	QPSK	21.31	21.26	21.04	
			16QAM	20.67	20.61	20.52	
		Middle	QPSK	21.29	21.31	20.97	
			16QAM	20.65	20.55	20.32	
		Low	QPSK	21.27	21.18	20.94	
			16QAM	20.59	20.55	20.44	
15RB		/	QPSK	21.23	20.91	20.47	
			16QAM	20.37	20.35	20.15	

5MHz	1RB	High	QPSK	22.65	22.76	22.64
			16QAM	22.38	22.42	22.26
		Middle	QPSK	22.56	22.73	22.45
			16QAM	22.35	22.35	22.04
		Low	QPSK	22.60	22.68	22.53
			16QAM	22.28	22.34	22.17
	12RB	High	QPSK	21.27	21.31	21.01
			16QAM	20.63	20.66	20.49
		Middle	QPSK	21.25	21.36	20.94
			16QAM	20.60	20.60	20.29
		Low	QPSK	21.22	21.23	20.91
			16QAM	20.54	20.59	20.40
	25RB	/	QPSK	21.19	20.96	20.44
			16QAM	20.32	20.39	20.12
10MHz	1RB	High	QPSK	22.62	22.79	22.62
			16QAM	22.35	22.44	22.24
		Middle	QPSK	22.53	22.76	22.43
			16QAM	22.33	22.38	22.03
		Low	QPSK	22.58	22.70	22.51
			16QAM	22.26	22.37	22.15
	25RB	High	QPSK	21.24	21.33	21.00
			16QAM	20.61	20.68	20.47
		Middle	QPSK	21.22	21.38	20.93
			16QAM	20.58	20.62	20.27
		Low	QPSK	21.20	21.25	20.89
			16QAM	20.52	20.61	20.39
	50RB	/	QPSK	21.17	20.98	20.43
			16QAM	20.30	20.42	20.10

15MHz	1RB	High	QPSK	22.67	22.76	22.65
			16QAM	22.07	22.16	22.03
		Middle	QPSK	22.58	22.73	22.46
			16QAM	22.04	22.09	21.82
		Low	QPSK	22.62	22.68	22.54
			16QAM	21.98	22.08	21.94
	36RB	High	QPSK	21.29	21.30	21.02
			16QAM	20.34	20.42	20.28
		Middle	QPSK	21.27	21.36	20.95
			16QAM	20.32	20.36	20.08
		Low	QPSK	21.24	21.22	20.92
			16QAM	20.26	20.35	20.20
	75RB	/	QPSK	21.21	20.95	20.45
			16QAM	20.04	20.16	19.91

LTE-TDD Band 41				Actual output Power (dBm)				
Band-width	RBAallocation	RBOffset	Modulation	Low	Middle1	Middle2	Middle3	High
5MHz	1RB	High	QPSK	21.54	21.52	21.58	21.56	21.53
			16QAM	21.28	21.19	21.22	21.23	21.17
		Middle	QPSK	21.45	21.49	21.40	21.53	21.35
			16QAM	21.26	21.13	21.01	21.17	20.97
		Low	QPSK	21.49	21.44	21.48	21.48	21.43
			16QAM	21.19	21.12	21.14	21.16	21.09
	12RB	High	QPSK	20.23	20.14	20.03	20.18	19.98
			16QAM	19.62	19.53	19.53	19.57	19.49
		Middle	QPSK	20.21	20.19	19.96	20.23	19.92
			16QAM	19.60	19.48	19.34	19.51	19.30
		Low	QPSK	20.18	20.07	19.93	20.11	19.89
			16QAM	19.54	19.47	19.45	19.50	19.41
	25RB		QPSK	20.15	19.81	19.49	19.85	19.44
			16QAM	19.33	19.28	19.18	19.32	19.14
10MHz	1RB	High	QPSK	21.52	21.55	21.57	21.59	21.52
			16QAM	21.26	21.22	21.21	21.26	21.16
		Middle	QPSK	21.43	21.52	21.39	21.56	21.34
			16QAM	21.23	21.16	21.00	21.20	20.95
		Low	QPSK	21.47	21.47	21.47	21.51	21.42
			16QAM	21.17	21.15	21.12	21.19	21.07
	25RB	High	QPSK	20.20	20.17	20.02	20.20	19.97
			16QAM	19.60	19.55	19.52	19.59	19.47
		Middle	QPSK	20.19	20.22	19.95	20.25	19.91
			16QAM	19.57	19.50	19.33	19.53	19.28
		Low	QPSK	20.16	20.09	19.92	20.13	19.87
			16QAM	19.52	19.49	19.44	19.53	19.40
	50RB	/	QPSK	20.13	19.84	19.47	19.87	19.43
			16QAM	19.31	19.30	19.17	19.34	19.12



15MHz	1RB	High	QPSK	21.56	21.52	21.59	21.56	21.54
			16QAM	21.30	21.19	21.23	21.23	21.18
		Middle	QPSK	21.47	21.49	21.41	21.53	21.36
			16QAM	21.28	21.13	21.02	21.17	20.98
		Low	QPSK	21.51	21.44	21.49	21.48	21.44
			16QAM	21.21	21.12	21.15	21.16	21.10
	36RB	High	QPSK	20.24	20.14	20.04	20.18	19.99
			16QAM	19.64	19.53	19.54	19.57	19.49
		Middle	QPSK	20.23	20.19	19.97	20.23	19.93
			16QAM	19.61	19.47	19.35	19.51	19.31
		Low	QPSK	20.20	20.07	19.94	20.10	19.90
			16QAM	19.56	19.47	19.46	19.50	19.42
	75RB	/	QPSK	20.17	19.81	19.50	19.85	19.45
			16QAM	19.35	19.28	19.19	19.32	19.14
20MHz	1RB	High	QPSK	21.63	21.59	21.67	21.63	21.62
			16QAM	20.85	20.83	20.85	20.83	20.85
		Middle	QPSK	21.61	21.61	21.69	21.68	21.64
			16QAM	20.87	20.82	20.88	20.86	20.87
		Low	QPSK	21.66	21.62	21.67	21.65	21.62
			16QAM	20.84	20.80	20.83	20.82	20.87
	50RB	High	QPSK	20.66	20.82	20.84	20.80	20.68
			16QAM	19.71	19.75	19.81	19.76	19.68
		Middle	QPSK	20.70	20.75	20.80	20.79	20.70
			16QAM	19.72	19.77	19.81	19.78	19.69
		Low	QPSK	20.71	20.73	20.76	20.81	20.68
			16QAM	19.78	19.74	19.81	19.78	19.67
	100RB	/	QPSK	20.72	20.78	20.84	20.81	20.72
			16QAM	19.75	19.77	19.83	19.90	19.69

TDD test:

TDD testing is performed using guidance from FCC KDB 941225 D05v02r03 and the SAR test guidance provided in April 2013 TCB works hop notes. TDD is tested at the highest duty factor using UL-DL configuration 0 with special subframe configuration 6 and applying the FDD LTE procedures in KDB 941225 D05v02r03. SAR testing is performed using the extended cyclic prefix listed in 3GPP TS 36.211.

**Frame structure type 2 (for 5 ms switch-point periodicity)**

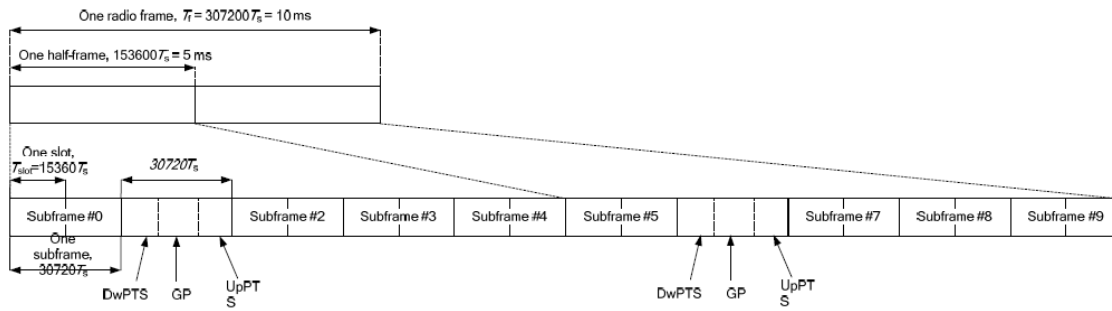

**Configuration of special subframe (lengths of DwPTS/GP/UpPTS)**

Special subframe configuration	Normal cyclic prefix in downlink			Extended cyclic prefix in downlink		
	DwPTS	UpPTS		DwPTS	UpPTS	
		Normal cyclic prefix in uplink	Extended cyclic prefix in uplink		Normal cyclic prefix in uplink	Extended cyclic prefix in uplink
0	$6592 \cdot T_s$	$2192 \cdot T_s$	$2560 \cdot T_s$	$7680 \cdot T_s$	$2192 \cdot T_s$	$2560 \cdot T_s$
1	$19760 \cdot T_s$			$20480 \cdot T_s$		
2	$21952 \cdot T_s$			$23040 \cdot T_s$		
3	$24144 \cdot T_s$			$25600 \cdot T_s$		
4	$26336 \cdot T_s$			$7680 \cdot T_s$		
5	$6592 \cdot T_s$	$4384 \cdot T_s$	$5120 \cdot T_s$	$20480 \cdot T_s$	$4384 \cdot T_s$	$5120 \cdot T_s$
6	$19760 \cdot T_s$			$23040 \cdot T_s$		
7	$21952 \cdot T_s$			$12800 \cdot T_s$		
8	$24144 \cdot T_s$			-		
9	$13168 \cdot T_s$			-		

**Uplink-downlink configurations**

Uplink-downlink configuration	Downlink-to-Uplink Switch-point periodicity	Subframe number									
		0	1	2	3	4	5	6	7	8	9
0	5 ms	D	S	U	U	U	D	S	U	U	U
1	5 ms	D	S	U	U	D	D	S	U	U	D
2	5 ms	D	S	U	D	D	D	S	U	D	D
3	10 ms	D	S	U	U	U	D	D	D	D	D
4	10 ms	D	S	U	U	D	D	D	D	D	D
5	10 ms	D	S	U	D	D	D	D	D	D	D
6	5 ms	D	S	U	U	U	D	S	U	U	D

The highest duty factor is resulted from:

- Uplink-downlink configuration: 0. In a half-frame consisted of 5 subframes, uplink operation is in 3 uplink subframes and 1 special subframe.
- Special subframe configuration: 5-9 for normal cyclic prefix in downlink, 4-7 for extended cyclic prefix in downlink.
- For special subframe with extended cyclic prefix in uplink, the total uplink duty factor in one half-frame is  $(3+0.167)/5=63.3\%$
- For special subframe with normal cyclic prefix in uplink, the total uplink duty factor in one half-frame is  $(3+0.143)/5=62.9\%$
- For TDD LTE SAR measurement, the duty cycle 1:1.59 (62.9%) was used perform testing and considering the theoretical duty cycle of 63.3% for extended cyclic prefix in the uplink, and the theoretical duty cycle of 62.9% for normal cyclic prefix in uplink, a scaling factor of extended cyclic prefix  $63.3\%/62.9\%=1.006$  is applied to scale-up the measured SAR result. The scaled TDD LTE SAR =measured SAR (W/kg)\* Tune-up Scaling Factor \*scaling factor for extended cyclic prefix.

**WLAN Conducted Power**

For 2.4GHz WLAN SAR testing, highest average RF output power channel for the lowest data rate for 802.11b were for SAR evaluation. 802.11g/n were not investigated since the average putput powers over all channels and data rates were not more than 0.25dB higher than the tested channel in the lowest data rate of 802.11b mode.

WIFI					
Mode	Channel	Frequency (MHz)	Conducted Peak Power (dBm)	Conducted Average Power (dBm)	Data rate
802.11b	01	2412	12.59	10.74	1 Mbps
	06	2437	13.33	11.37	1 Mbps
	11	2462	12.60	10.74	1 Mbps
802.11g	01	2412	14.47	11.08	6 Mbps
	06	2437	13.99	10.93	6 Mbps
	11	2462	13.16	10.29	6 Mbps
802.11n(H20)	01	2412	12.41	9.46	6.5 Mbps
	06	2437	13.53	10.30	6.5 Mbps
	11	2462	12.95	9.86	6.5 Mbps

Note: The output power was test all data rate and recorded worst case at recorded data rate.

**Bluetooth Conducted Power**

Bluetooth			
Mode	Channel	Frequency (MHz)	Conducted power (dBm)
GFSK	0	2402	7.11
	39	2441	8.43
	78	2480	6.57
$\pi/4$ QPSK	0	2402	7.62
	39	2441	8.87
	78	2480	7.04
8DPSK	0	2402	7.58
	39	2441	8.85
	78	2480	7.07
BLE(GFSK)	0	2402	-2.17
	19	2440	-1.25
	39	2480	-2.64

## 12. Maximum Tune-up Limit

PTT			
Mode	Modulation	Operation Frequency Range	Tune up power
TMO / DMO	$\pi/4$ DQPSK	450MHz~470MHz	33.50dBm

Mode	Burst Average Power (dBm)	
	GSM850	PCS1900
GSM (GMSK, 1Tx Slot)	34.00	30.00
GPRS (GMSK, 1Tx Slot)	34.00	30.00
GPRS (GMSK, 2Tx Slot)	31.50	28.00
GPRS (GMSK, 3Tx Slot)	29.50	26.50
GPRS (GMSK, 4Tx Slot)	28.50	25.50
EGPRS (GMSK, 1Tx Slot)	34.00	30.00
EGPRS (GMSK, 2Tx Slot)	31.50	28.00
EGPRS (GMSK, 3Tx Slot)	29.50	26.50
EGPRS (GMSK, 4Tx Slot)	28.50	25.50
EGPRS (8PSK, 1Tx Slot)	26.00	25.00
EGPRS (8PSK, 2Tx Slot)	25.50	24.50
EGPRS (8PSK, 3Tx Slot)	24.00	23.50
EGPRS (8PSK, 4Tx Slot)	23.00	22.50

LTE	
LTE Band	Maximum Tune-up (dBm)
LTE Band 2	22.50
LTE Band 4	22.50
LTE Band 5	22.50
LTE Band 7	22.00
LTE Band 26	23.00
LTE Band 41	22.00

### LTE MPR will followup 3GPP setting as below:

Modulation	Channel bandwidth / Transmission bandwidth (NRB)						MPR (dB)
	1.4MHz	3.0MHz	5MHz	10MHz	15MHz	20MHz	
QPSK	$\leq 5$	$\leq 4$	$\leq 8$	$\leq 12$	$\leq 16$	$\leq 18$	0
QPSK	$> 5$	$> 4$	$> 8$	$> 12$	$> 16$	$> 18$	1
16 QAM	$\leq 5$	$\leq 4$	$\leq 8$	$\leq 12$	$\leq 16$	$\leq 18$	1
16 QAM	$> 5$	$> 4$	$> 8$	$> 12$	$> 16$	$> 18$	2

WIFI					
Mode	Channel	Frequency (MHz)	Conducted Peak Power (dBm)	Conducted Average Power (dBm)	Data rate
802.11b	01	2412	14.00	11.50	1 Mbps
	06	2437	14.00	11.50	1 Mbps
	11	2462	14.00	11.50	1 Mbps
802.11g	01	2412	15.00	11.50	6 Mbps
	06	2437	15.00	11.50	6 Mbps
	11	2462	15.00	11.50	6 Mbps
802.11n(H20)	01	2412	14.00	10.00	6.5 Mbps
	06	2437	14.00	11.00	6.5 Mbps
	11	2462	14.00	10.00	6.5 Mbps

Bluetooth			
Mode	Channel	Frequency (MHz)	Conducted power (dBm)
GFSK	0	2402	8.00
	39	2441	9.00
	78	2480	7.00
$\pi/4$ QPSK	0	2402	8.00
	39	2441	9.00
	78	2480	8.00
8DPSK	0	2402	8.00
	39	2441	9.00
	78	2480	8.00
BLE(GFSK)	0	2402	-2.00
	19	2440	-1.00
	39	2480	-2.00

Per KDB 447498 D01, the 1-g and 10-g SAR test exclusion thresholds for 100MHz to 6GHz at test separation distances  $\leq 50$ mm are determined by:

$$[(\text{max. Power of channel, including tune-up tolerance, mW}) / (\text{min. test separation distance, mm})] * [\sqrt{f(\text{GHz})}] \leq 3.0 \text{ for 1-g SAR}$$

Band/Mode	F(GHz)	Position	SAR test exclusion threshold (mW)	RF output power		SAR test exclusion
				dBm	mW	
Bluetooth	2.45	Head	9.6	9	7.94	Yes
		Body	19.2	9	7.94	Yes

Per KDB 447498 D01, when the minimum test separation distance is <5mm, a distance of 5mm is applied to determine SAR test exclusion.

The test exclusion threshold is  $\leq 3$ , SAR testing is not required.

### 13. Antenna Location

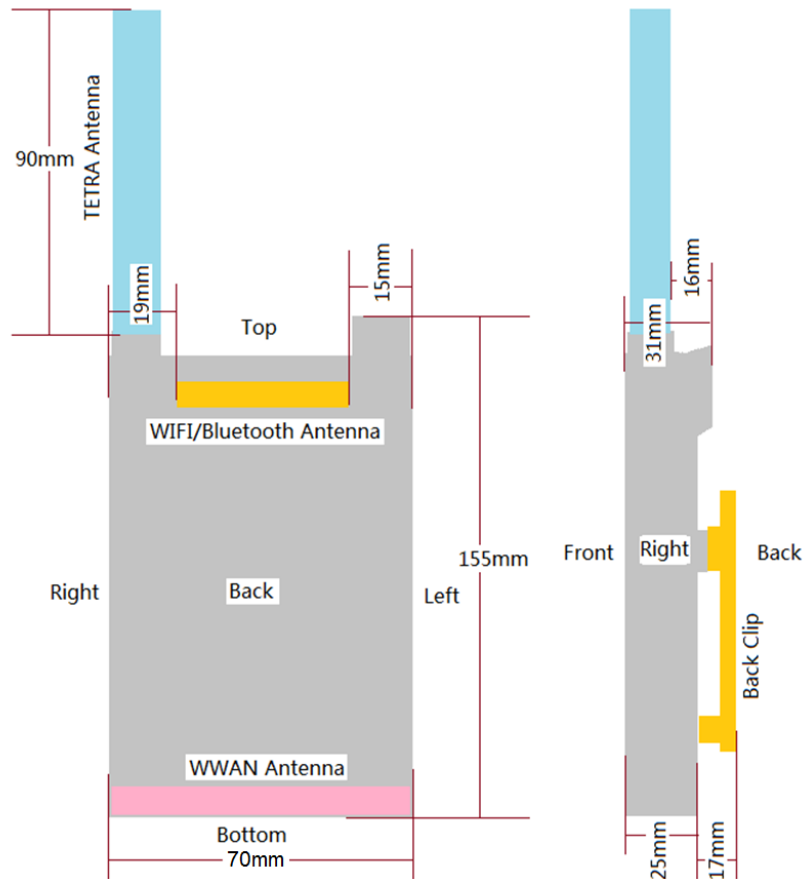

Positions for SAR tests; Hotspot mode						
Antenna	Back	Front	Top side	Bottom side	Right side	Left side
WWAN	Yes	Yes	No	Yes	Yes	Yes
WIFI / BT	Yes	Yes	Yes	No	Yes	Yes

**General note:**

Referring to KDB941225 D06, when the overall device length and width are >9cm\*5cm, the test distance is 10mm. SAR must be measured for all sides and surfaces with a transmitting antenna located within 25mm from that surface or edge.

## 14. SAR Measurement Results

### TETRA Test data

Front of Face										
Mode	Frequency		Conducted Power (dBm)	Tune up limit (dBm)	Tune up scaling factor	Power Drift(dB)	Measured SAR(1g)	Report SAR(1g)	50% Duty SAR	Test Plot
	CH	MHz					(W/kg)	(W/kg)	(W/kg)	
TMO	CH1	450.05	33.10	33.50	1.10	-	-	-	-	-
	CH2	460.00	33.10	33.50	1.10	-0.07	2.68	2.94	1.47	TF
	CH3	469.95	33.25	33.50	1.06	-	-	-	-	-
DMO	CH1	450.05	33.10	33.50	1.10	-	-	-	-	-
	CH2	460.00	33.10	33.50	1.10	0.06	2.75	3.02	1.51	DF
	CH3	469.95	33.00	33.50	1.12	-	-	-	-	-

Body-worn (with Back Clip)										
Mode	Frequency		Conducted Power (dBm)	Tune up limit (dBm)	Tune up scaling factor	Power Drift(dB)	Measured SAR(1g)	Report SAR(1g)	50% Duty SAR	Test Plot
	CH	MHz					(W/kg)	(W/kg)	(W/kg)	
TMO	CH1	450.05	33.10	33.50	1.10	-	-	-	-	-
	CH2	460.00	33.10	33.50	1.10	-0.08	1.43	1.57	0.78	-
	CH3	469.95	33.25	33.50	1.06	-	-	-	-	-
DMO	CH1	450.05	33.10	33.50	1.10	-	-	-	-	-
	CH2	460.00	33.10	33.50	1.10	0.07	1.66	1.82	0.91	-
	CH3	469.95	33.00	33.50	1.12	-	-	-	-	-

Body-worn (without Back Clip)										
Mode	Frequency		Conducted Power (dBm)	Tune up limit (dBm)	Tune up scaling factor	Power Drift(dB)	Measured SAR(1g)	Report SAR(1g)	50% Duty SAR	Test Plot
	CH	MHz					(W/kg)	(W/kg)	(W/kg)	
TMO	CH1	450.05	33.10	33.50	1.10	-	-	-	-	-
	CH2	460.00	33.10	33.50	1.10	0.10	3.56	3.90	1.95	TB
	CH3	469.95	33.25	33.50	1.06	-	-	-	-	-
DMO	CH1	450.05	33.10	33.50	1.10	-	-	-	-	-
	CH2	460.00	33.10	33.50	1.10	0.16	3.72	4.08	2.04	DB
	CH3	469.95	33.00	33.50	1.12	-	-	-	-	-

Note:

- The value with blue color is the maximum SAR Value of each test band.
- Batteries are fully charged at the beginning of the SAR measurements
- The EUT was tested for face-held SAR with a 2.5cm separation distance between the front of the EUT and the outer surface of the planer phantom.
- The EUT was tested for body-worn SAR with a 0cm separation distance between the rear of the EUT with back clip and the outer surface of the planer phantom.
- The EUT was tested for body-worn SAR with a 1.0cm separation distance between the rear of the EUT without back clip and the outer surface of the planer phantom.
- When the SAR for all antennas tested using the default battery is  $\leq 3.5$  W/kg (50% PTT duty factor), testing of all other required channels is not necessary.
- When the SAR of an antenna tested on the highest output power using the default battery is  $> 3.5$  W/Kg and  $\leq 4.0$  W/Kg (50% PTT duty factor), testing of the immediately adjacent channel(s) is not necessary, but testing of other required channels may still be required.
- When the SAR for all antennas tested using the default battery  $\leq 4.0$  W/kg (50% PTT duty factor), test additional batteries using the antenna and channel configuration that resulted in the highest SAR.

**Head SAR**

GSM850										
Mode	Test Position	Frequency		Conducted Power (dBm)	Tune up limit (dBm)	Tune up scaling factor	Power Drift(dB)	Measured SAR(1g) (W/kg)	Report SAR(1g) (W/kg)	Test Plot
		CH	MHz							
<b>With the TETRA Antenna</b>										
GPRS (4Tx slot)	Left-Cheek	128	824.2	28.02	28.50	1.12	-	-	-	-
		190	836.6	28.11	28.50	1.09	-0.03	0.367	0.402	H1
		251	848.8	27.91	28.50	1.15	-	-	-	-
	Left-Tilt	128	824.2	28.02	28.50	1.12	-	-	-	-
		190	836.6	28.11	28.50	1.09	0.03	0.281	0.307	-
		251	848.8	27.91	28.50	1.15	-	-	-	-
	Right-Cheek	128	824.2	28.02	28.50	1.12	-	-	-	-
		190	836.6	28.11	28.50	1.09	0.01	0.340	0.372	-
		251	848.8	27.91	28.50	1.15	-	-	-	-
	Right-Tilt	128	824.2	28.02	28.50	1.12	-	-	-	-
		190	836.6	28.11	28.50	1.09	-0.02	0.258	0.282	-
		251	848.8	27.91	28.50	1.15	-	-	-	-
<b>Without the TETRA Antenna (only show the worst mode)</b>										
GPRS (4Tx slot)	Left-Cheek	190	836.6	28.11	28.50	1.12	0.10	0.359	0.393	-

PCS1900										
Mode	Test Position	Frequency		Conducted Power (dBm)	Tune up limit (dBm)	Tune up scaling factor	Power Drift(dB)	Measured SAR(1g) (W/kg)	Report SAR(1g) (W/kg)	Test Plot
		CH	MHz							
<b>With the TETRA Antenna</b>										
GPRS (4Tx slot)	Left-Cheek	512	1850.2	24.94	25.50	1.14	-	-	-	-
		661	1880.0	24.93	25.50	1.14	0.18	0.284	0.324	H2
		810	1909.8	24.52	25.50	1.25	-	-	-	-
	Left-Tilt	512	1850.2	24.94	25.50	1.14	-	-	-	-
		661	1880.0	24.93	25.50	1.14	0.13	0.228	0.260	-
		810	1909.8	24.52	25.50	1.25	-	-	-	-
	Right-Cheek	512	1850.2	24.94	25.50	1.14	-	-	-	-
		661	1880.0	24.93	25.50	1.14	-0.09	0.273	0.311	-
		810	1909.8	24.52	25.50	1.25	-	-	-	-
	Right-Tilt	512	1850.2	24.94	25.50	1.14	-	-	-	-
		661	1880.0	24.93	25.50	1.14	-0.11	0.215	0.245	-
		810	1909.8	24.52	25.50	1.25	-	-	-	-
<b>Without the TETRA Antenna (only show the worst mode)</b>										
GPRS (4Tx slot)	Left-Cheek	661	1880.0	24.93	25.50	1.14	-0.09	0.267	0.304	-

Note:

Per KDB865664 D01v01r04, Repeated measurement is not required when the original highest measured SAR is &lt; 0.80 W/kg



LTE Band 2										
Mode	Test Position	Frequency		Conducted Power (dBm)	Tune up limit (dBm)	Tune up scaling factor	Power Drift(dB)	Measured SAR(1g) (W/kg)	Report SAR(1g) (W/kg)	Test Plot
		CH	MHz							
<b>With the TETRA Antenna</b>										
20M_1 RB	Left-Cheek	18700	1860.0	21.72	22.50	1.20	-	-	-	-
		18900	1880.0	21.82	22.50	1.17	-0.04	0.197	0.230	H3
		19100	1900.0	21.79	22.50	1.18	-	-	-	-
	Left-Tilt	18700	1860.0	21.72	22.50	1.20	-	-	-	-
		18900	1880.0	21.82	22.50	1.17	0.03	0.161	0.189	-
		19100	1900.0	21.79	22.50	1.18	-	-	-	-
	Right-Cheek	18700	1860.0	21.72	22.50	1.20	-	-	-	-
		18900	1880.0	21.82	22.50	1.17	0.02	0.192	0.224	-
		19100	1900.0	21.79	22.50	1.18	-	-	-	-
	Right-Tilt	18700	1860.0	21.72	22.50	1.20	-	-	-	-
		18900	1880.0	21.82	22.50	1.17	-0.02	0.153	0.179	-
		19100	1900.0	21.79	22.50	1.18	-	-	-	-
20M_5 ORB	Left-Cheek	18700	1860.0	20.39	21.00	1.15	-	-	-	-
		18900	1880.0	20.42	21.00	1.14	-0.11	0.156	0.178	-
		19100	1900.0	20.22	21.00	1.20	-	-	-	-
	Left-Tilt	18700	1860.0	20.39	21.00	1.15	-	-	-	-
		18900	1880.0	20.42	21.00	1.14	0.06	0.137	0.156	-
		19100	1900.0	20.22	21.00	1.20	-	-	-	-
	Right-Cheek	18700	1860.0	20.39	21.00	1.15	-	-	-	-
		18900	1880.0	20.42	21.00	1.14	0.05	0.144	0.165	-
		19100	1900.0	20.22	21.00	1.20	-	-	-	-
	Right-Tilt	18700	1860.0	20.39	21.00	1.15	-	-	-	-
		18900	1880.0	20.42	21.00	1.14	-0.04	0.123	0.140	-
		19100	1900.0	20.22	21.00	1.20	-	-	-	-
<b>Without the TETRA Antenna (only show the worst mode)</b>										
20M_1 RB	Left-Cheek	18900	1880.0	21.82	22.50	1.17	0.11	0.193	0.226	-

Note:

1. Per KDB865664 D01v01r04, Repeated measurement is not required when the original highest measured SAR is < 0.80 W/kg
2. Per KDB 941225 D05v02r03, for QPSK with 100% RB allocation, SAR is not required when the highest maximum output power for 100 % RB allocation is less than the highest maximum output power in 50% and 1 RB allocations and the highest reported SAR for 1 RB and 50% RB allocation are ≤ 0.8 W/kg. Otherwise, SAR is measured for the highest output power channel; and if the reported SAR is > 1.45 W/kg, the remaining required test channels must also be tested.

LTE Band 4										
Mode	Test Position	Frequency		Conducted Power (dBm)	Tune up limit (dBm)	Tune up scaling factor	Power Drift(dB)	Measured SAR(1g) (W/kg)	Report SAR(1g) (W/kg)	Test Plot
		CH	MHz							
<b>With the TETRA Antenna</b>										
20M_1 RB	Left-Cheek	20050	1720	22.25	22.50	1.06	-	-	-	-
		20175	1732.5	22.33	22.50	1.04	0.10	0.221	0.230	H4
		20300	1745	22.23	22.50	1.06	-	-	-	-
	Left-Tilt	20050	1720	22.25	22.50	1.06	-	-	-	-
		20175	1732.5	22.33	22.50	1.04	-0.01	0.165	0.172	-
		20300	1745	22.23	22.50	1.06	-	-	-	-
	Right-Cheek	20050	1720	22.25	22.50	1.06	-	-	-	-
		20175	1732.5	22.33	22.50	1.04	-0.05	0.215	0.223	-
		20300	1745	22.23	22.50	1.06	-	-	-	-
	Right-Tilt	20050	1720	22.25	22.50	1.06	-	-	-	-
		20175	1732.5	22.33	22.50	1.04	0.03	0.166	0.173	-
		20300	1745	22.23	22.50	1.06	-	-	-	-
20M_5 ORB	Left-Cheek	20050	1720	20.89	21.50	1.15	-	-	-	-
		20175	1732.5	20.90	21.50	1.15	0.16	0.152	0.174	-
		20300	1745	20.63	21.50	1.22	-	-	-	-
	Left-Tilt	20050	1720	20.89	21.50	1.15	-	-	-	-
		20175	1732.5	20.90	21.50	1.15	-0.13	0.120	0.138	-
		20300	1745	20.63	21.50	1.22	-	-	-	-
	Right-Cheek	20050	1720	20.89	21.50	1.15	-	-	-	-
		20175	1732.5	20.90	21.50	1.15	-0.07	0.138	0.158	-
		20300	1745	20.63	21.50	1.22	-	-	-	-
	Right-Tilt	20050	1720	20.89	21.50	1.15	-	-	-	-
		20175	1732.5	20.90	21.50	1.15	0.09	0.098	0.112	-
		20300	1745	20.63	21.50	1.22	-	-	-	-
<b>Without the TETRA Antenna (only show the worst mode)</b>										
20M_1 RB	Left-Cheek	20175	1732.5	22.33	22.50	1.04	0.07	0.213	0.222	-

Note:

1. Per KDB865664 D01v01r04, Repeated measurement is not required when the original highest measured SAR is < 0.80 W/kg
2. Per KDB 941225 D05v02r03, for QPSK with 100% RB allocation, SAR is not required when the highest maximum output power for 100 % RB allocation is less than the highest maximum output power in 50% and 1 RB allocations and the highest reported SAR for 1 RB and 50% RB allocation are ≤ 0.8 W/kg. Otherwise, SAR is measured for the highest output power channel; and if the reported SAR is > 1.45 W/kg, the remaining required test channels must also be tested.

LTE Band 5										
Mode	Test Position	Frequency		Conducted Power (dBm)	Tune up limit (dBm)	Tune up scaling factor	Power Drift(dB)	Measured SAR(1g) (W/kg)	Report SAR(1g) (W/kg)	Test Plot
		CH	MHz							
<b>With the TETRA Antenna</b>										
10M_1 RB	Left-Cheek	20450	829	22.21	22.50	1.07	-	-	-	-
		20525	836.5	22.23	22.50	1.06	-0.11	0.246	0.262	H5
		20600	844	22.19	22.50	1.07	-	-	-	-
	Left-Tilt	20450	829	22.21	22.50	1.07	-	-	-	-
		20525	836.5	22.23	22.50	1.06	-0.06	0.206	0.219	-
		20600	844	22.19	22.50	1.07	-	-	-	-
	Right-Cheek	20450	829	22.21	22.50	1.07	-	-	-	-
		20525	836.5	22.23	22.50	1.06	0.08	0.238	0.253	-
		20600	844	22.19	22.50	1.07	-	-	-	-
	Right-Tilt	20450	829	22.21	22.50	1.07	-	-	-	-
		20525	836.5	22.23	22.50	1.06	-0.04	0.188	0.201	-
		20600	844	22.19	22.50	1.07	-	-	-	-
10M_2 5RB	Left-Cheek	20450	829	20.85	21.00	1.03	-	-	-	-
		20525	836.5	20.81	21.00	1.05	0.07	0.205	0.214	-
		20600	844	20.59	21.00	1.10	-	-	-	-
	Left-Tilt	20450	829	20.85	21.00	1.03	-	-	-	-
		20525	836.5	20.81	21.00	1.05	-0.04	0.159	0.166	-
		20600	844	20.59	21.00	1.10	-	-	-	-
	Right-Cheek	20450	829	20.85	21.00	1.03	-	-	-	-
		20525	836.5	20.81	21.00	1.05	0.03	0.204	0.213	-
		20600	844	20.59	21.00	1.10	-	-	-	-
	Right-Tilt	20450	829	20.85	21.00	1.03	-	-	-	-
		20525	836.5	20.81	21.00	1.05	0.04	0.167	0.174	-
		20600	844	20.59	21.00	1.10	-	-	-	-
<b>Without the TETRA Antenna (only show the worst mode)</b>										
10M_1 RB	Left-Cheek	20525	836.5	22.23	22.50	1.06	-0.07	0.239	0.254	-

Note:

1. Per KDB865664 D01v01r04, Repeated measurement is not required when the original highest measured SAR is < 0.80 W/kg
2. Per KDB 941225 D05v02r03, for QPSK with 100% RB allocation, SAR is not required when the highest maximum output power for 100 % RB allocation is less than the highest maximum output power in 50% and 1 RB allocations and the highest reported SAR for 1 RB and 50% RB allocation are ≤ 0.8 W/kg. Otherwise, SAR is measured for the highest output power channel; and if the reported SAR is > 1.45 W/kg, the remaining required test channels must also be tested.

LTE Band 7										
Mode	Test Position	Frequency		Conducted Power (dBm)	Tune up limit (dBm)	Tune up scaling factor	Power Drift(dB)	Measured SAR(1g) (W/kg)	Report SAR(1g) (W/kg)	Test Plot
		CH	MHz							
<b>With the TETRA Antenna</b>										
20M_1 RB	Left-Cheek	20850	2510	21.51	22.00	1.12	-	-	-	-
		21100	2535	21.59	22.00	1.10	0.12	0.168	0.185	H6
		21350	2560	21.52	22.00	1.12	-	-	-	-
	Left-Tilt	20850	2510	21.51	22.00	1.12	-	-	-	-
		21100	2535	21.59	22.00	1.10	0.01	0.147	0.162	-
		21350	2560	21.52	22.00	1.12	-	-	-	-
	Right-Cheek	20850	2510	21.51	22.00	1.12	-	-	-	-
		21100	2535	21.59	22.00	1.10	-0.05	0.162	0.178	-
		21350	2560	21.52	22.00	1.12	-	-	-	-
	Right-Tilt	20850	2510	21.51	22.00	1.12	-	-	-	-
		21100	2535	21.59	22.00	1.10	0.04	0.138	0.152	-
		21350	2560	21.52	22.00	1.12	-	-	-	-
20M_5 ORB	Left-Cheek	20850	2510	20.20	20.50	1.07	-	-	-	-
		21100	2535	20.21	20.50	1.07	0.09	0.139	0.149	-
		21350	2560	19.97	20.50	1.13	-	-	-	-
	Left-Tilt	20850	2510	20.20	20.50	1.07	-	-	-	-
		21100	2535	20.21	20.50	1.07	-0.03	0.126	0.135	-
		21350	2560	19.97	20.50	1.13	-	-	-	-
	Right-Cheek	20850	2510	20.20	20.50	1.07	-	-	-	-
		21100	2535	20.21	20.50	1.07	0.02	0.132	0.142	-
		21350	2560	19.97	20.50	1.13	-	-	-	-
	Right-Tilt	20850	2510	20.20	20.50	1.07	-	-	-	-
		21100	2535	20.21	20.50	1.07	-0.04	0.108	0.116	-
		21350	2560	19.97	20.50	1.13	-	-	-	-
<b>Without the TETRA Antenna (only show the worst mode)</b>										
20M_1 RB	Left-Cheek	21100	2535	21.59	22.00	1.10	0.02	0.164	0.180	-

Note:

1. Per KDB865664 D01v01r04, Repeated measurement is not required when the original highest measured SAR is < 0.80 W/kg
2. Per KDB 941225 D05v02r03, for QPSK with 100% RB allocation, SAR is not required when the highest maximum output power for 100 % RB allocation is less than the highest maximum output power in 50% and 1 RB allocations and the highest reported SAR for 1 RB and 50% RB allocation are ≤ 0.8 W/kg. Otherwise, SAR is measured for the highest output power channel; and if the reported SAR is > 1.45 W/kg, the remaining required test channels must also be tested.

LTE Band 26										
Mode	Test Position	Frequency		Conducted Power (dBm)	Tune up limit (dBm)	Tune up scaling factor	Power Drift(dB)	Measured SAR(1g) (W/kg)	Report SAR(1g) (W/kg)	Test Plot
		CH	MHz							
<b>With the TETRA Antenna</b>										
15M_1 RB	Left-Cheek	26775	822.5	22.67	23.00	1.08	-	-	-	-
		26865	831.5	22.76	23.00	1.06	0.16	0.264	0.279	H7
		26965	841.5	22.65	23.00	1.08	-	-	-	-
	Left-Tilt	26775	822.5	22.67	23.00	1.08	-	-	-	-
		26865	831.5	22.76	23.00	1.06	0.04	0.231	0.245	-
		26965	841.5	22.65	23.00	1.08	-	-	-	-
	Right-Cheek	26775	822.5	22.67	23.00	1.08	-	-	-	-
		26865	831.5	22.76	23.00	1.06	-0.06	0.254	0.269	-
		26965	841.5	22.65	23.00	1.08	-	-	-	-
	Right-Tilt	26775	822.5	22.67	23.00	1.08	-	-	-	-
		26865	831.5	22.76	23.00	1.06	0.08	0.203	0.214	-
		26965	841.5	22.65	23.00	1.08	-	-	-	-
15M_3 6RB	Left-Cheek	26775	822.5	21.29	21.50	1.05	-	-	-	-
		26865	831.5	21.30	21.50	1.05	-0.11	0.196	0.205	-
		26965	841.5	21.02	21.50	1.12	-	-	-	-
	Left-Tilt	26775	822.5	21.29	21.50	1.05	-	-	-	-
		26865	831.5	21.30	21.50	1.05	0.01	0.148	0.155	-
		26965	841.5	21.02	21.50	1.12	-	-	-	-
	Right-Cheek	26775	822.5	21.29	21.50	1.05	-	-	-	-
		26865	831.5	21.30	21.50	1.05	-0.05	0.194	0.203	-
		26965	841.5	21.02	21.50	1.12	-	-	-	-
	Right-Tilt	26775	822.5	21.29	21.50	1.05	-	-	-	-
		26865	831.5	21.30	21.50	1.05	-0.08	0.168	0.176	-
		26965	841.5	21.02	21.50	1.12	-	-	-	-
<b>Without the TETRA Antenna (only show the worst mode)</b>										
15M_1 RB	Left-Cheek	26865	831.5	22.76	23.00	1.06	-0.03	0.245	0.259	-

Note:

1. Per KDB865664 D01v01r04, Repeated measurement is not required when the original highest measured SAR is < 0.80 W/kg
2. Per KDB 941225 D05v02r03, for QPSK with 100% RB allocation, SAR is not required when the highest maximum output power for 100 % RB allocation is less than the highest maximum output power in 50% and 1 RB allocations and the highest reported SAR for 1 RB and 50% RB allocation are ≤ 0.8 W/kg. Otherwise, SAR is measured for the highest output power channel; and if the reported SAR is > 1.45 W/kg, the remaining required test channels must also be tested.

LTE Band 41											
Mode	Test Position	Frequency		Conducted Power (dBm)	Tune up limit (dBm)	Tune up scaling factor	Duty cycle scaling factor	Power Drift (dB)	Measured SAR(1g) (W/kg)	Report SAR(1g) (W/kg)	Test Plot
		CH	MHz								
<b>With the TETRA Antenna</b>											
20M_1R B	Left-Cheek	39750	2506	21.63	22.00	1.09	1.006	-	-	-	-
		40185	2549.5	21.59	22.00	1.10	1.006	-	-	-	-
		40620	2593	21.67	22.00	1.08	1.006	-0.10	0.084	0.091	H8
		41055	2636.5	21.63	22.00	1.09	1.006	-	-	-	-
		41490	2680	21.62	22.00	1.09	1.006	-	-	-	-
	Left-Tilt	39750	2506	21.63	22.00	1.09	1.006	-	-	-	-
		40185	2549.5	21.59	22.00	1.10	1.006	-	-	-	-
		40620	2593	21.67	22.00	1.08	1.006	-0.02	0.070	0.075	-
		41055	2636.5	21.63	22.00	1.09	1.006	-	-	-	-
		41490	2680	21.62	22.00	1.09	1.006	-	-	-	-
	Right-Cheek	39750	2506	21.63	22.00	1.09	1.006	-	-	-	-
		40185	2549.5	21.59	22.00	1.10	1.006	-	-	-	-
		40620	2593	21.67	22.00	1.08	1.006	0.03	0.082	0.089	-
		41055	2636.5	21.63	22.00	1.09	1.006	-	-	-	-
		41490	2680	21.62	22.00	1.09	1.006	-	-	-	-
	Right-Tilt	39750	2506	21.63	22.00	1.09	1.006	-	-	-	-
		40185	2549.5	21.59	22.00	1.10	1.006	-	-	-	-
		40620	2593	21.67	22.00	1.08	1.006	-0.05	0.065	0.071	-
		41055	2636.5	21.63	22.00	1.09	1.006	-	-	-	-
		41490	2680	21.62	22.00	1.09	1.006	-	-	-	-
20M_50 RB	Left-Cheek	39750	2506	20.66	21.00	1.08	1.006	-	-	-	-
		40185	2549.5	20.82	21.00	1.04	1.006	-	-	-	-
		40620	2593	20.84	21.00	1.04	1.006	0.16	0.060	0.063	-
		41055	2636.5	20.80	21.00	1.05	1.006	-	-	-	-
		41490	2680	20.68	21.00	1.08	1.006	-	-	-	-
	Left-Tilt	39750	2506	20.66	21.00	1.08	1.006	-	-	-	-
		40185	2549.5	20.82	21.00	1.04	1.006	-	-	-	-
		40620	2593	20.84	21.00	1.04	1.006	-0.02	0.044	0.046	-
		41055	2636.5	20.80	21.00	1.05	1.006	-	-	-	-
		41490	2680	20.68	21.00	1.08	1.006	-	-	-	-
	Right-Cheek	39750	2506	20.66	21.00	1.08	1.006	-	-	-	-
		40185	2549.5	20.82	21.00	1.04	1.006	-	-	-	-
		40620	2593	20.84	21.00	1.04	1.006	0.07	0.056	0.059	-
		41055	2636.5	20.80	21.00	1.05	1.006	-	-	-	-
		41490	2680	20.68	21.00	1.08	1.006	-	-	-	-
	Right-Tilt	39750	2506	20.66	21.00	1.08	1.006	-	-	-	-
		40185	2549.5	20.82	21.00	1.04	1.006	-	-	-	-
		40620	2593	20.84	21.00	1.04	1.006	0.12	0.049	0.052	-
		41055	2636.5	20.80	21.00	1.05	1.006	-	-	-	-
		41490	2680	20.68	21.00	1.08	1.006	-	-	-	-
<b>Without the TETRA Antenna (only show the worst mode)</b>											
20M_1R B	Left-Cheek	40620	2593	21.67	22.00	1.08	1.006	0.05	0.079	0.086	-

Note:

- Per KDB865664 D01v01r04, Repeated measurement is not required when the original highest measured SAR is < 0.80 W/kg
- Per KDB 941225 D05v02r03, for QPSK with 100% RB allocation, SAR is not required when the highest maximum output power for 100 % RB allocation is less than the highest maximum output power in 50% and 1 RB allocations and the highest reported SAR for 1 RB and 50% RB allocation are ≤ 0.8 W/kg. Otherwise, SAR is measured for the highest output power channel; and if the reported SAR is > 1.45 W/kg, the remaining required test channels must also be tested.

WLAN										
Mode	Test Position	Frequency		Conducted Power (dBm)	Tune up limit (dBm)	Tune up scaling factor	Power Drift(dB)	Measured SAR(1g) (W/kg)	Report SAR(1g) (W/kg)	Test Plot
		CH	MHz							
<b>With the TETRA Antenna</b>										
802.11 b 1Mbps	Left-Cheek	01	2412	10.74	11.50	1.19	-	-	-	-
		06	2437	11.37	11.50	1.03	-0.10	0.270	0.278	H9
		11	2462	10.74	11.50	1.19	-	-	-	-
	Left-Tilt	01	2412	10.74	11.50	1.19	-	-	-	-
		06	2437	11.37	11.50	1.03	0.14	0.229	0.236	-
		11	2462	10.74	11.50	1.19	-	-	-	-
	Right-Cheek	01	2412	10.74	11.50	1.19	-	-	-	-
		06	2437	11.37	11.50	1.03	0.05	0.259	0.267	-
		11	2462	10.74	11.50	1.19	-	-	-	-
	Right-Tilt	01	2412	10.74	11.50	1.19	-	-	-	-
		06	2437	11.37	11.50	1.03	-0.07	0.218	0.224	-
		11	2462	10.74	11.50	1.19	-	-	-	-
<b>Without the TETRA Antenna (only show the worst mode)</b>										
802.11 b 1Mbps	Left-Cheek	06	2437	11.37	11.50	1.03	0.05	0.258	0.266	-

Note:

1. According to the above table, the initial test position for head is “Left Cheek”, and its reported SAR is ≤ 0.4W/kg. Thus further SAR measurement is not required for the other (remaining) test positions. Because the reported SAR of the highest measured maximum output power channel for the exposure configuration is ≤ 0.8W/kg, no further SAR testing is required for 802.11b DSSS in that exposure configuration.
2. When SAR measurement is required for 2.4 GHz 802.11g/n OFDM configurations, the measurement and test reduction procedures for OFDM are applied. SAR is not required for the following 2.4 GHz OFDM conditions.
  - a) When KDB Publication 447498 D01 SAR test exclusion applies to the OFDM configuration.
  - b) When the highest *reported* SAR for DSSS is adjusted by the ratio of OFDM to DSSS specified maximum output power and the adjusted SAR is ≤ 1.2 W/kg, the 802.11g/n is not required.

WLAN- Scaled Reported SAR							
Mode	Test Position	Frequency		Actual duty factor	maximum duty factor	Reported SAR (1g)(W/kg)	Scaled reported SAR (1g)(W/kg)
		CH	MHz				
802.11b 1Mbps	Left-Cheek	6	2437	98.96%	100%	0.278	0.281
	Left-Tilt	6	2437	98.96%	100%	0.236	0.238
	Right-Cheek	6	2437	98.96%	100%	0.267	0.270
	Right-Tilt	6	2437	98.96%	100%	0.224	0.227

Note:

1. According to the KDB248227 D01, The reported SAR must be scaled to 100% transmission duty factor to determine compliance at the maximum tune-up tolerance limit. A maximum transmission duty factor of 98.96% is achievable for WLAN in this project.

**Body SAR**

GSM850										
Mode	Test Position	Frequency		Conducted Power (dBm)	Tune up limit (dBm)	Tune up scaling factor	Power Drift(dB)	Measured SAR(1g) (W/kg)	Report SAR(1g) (W/kg)	Test Plot
		CH	MHz							
GPRS (4Tx slot)	Front	128	824.2	28.02	28.50	1.12	-	-	-	-
		190	836.6	28.11	28.50	1.09	-0.02	0.119	0.130	-
		251	848.8	27.91	28.50	1.15	-	-	-	-
	Back	128	824.2	28.02	28.50	1.12	-	-	-	-
		190	836.6	28.11	28.50	1.09	0.05	0.180	0.197	B1
		251	848.8	27.91	28.50	1.15	-	-	-	-

PCS1900										
Mode	Test Position	Frequency		Conducted Power (dBm)	Tune up limit (dBm)	Tune up scaling factor	Power Drift(dB)	Measured SAR(1g) (W/kg)	Report SAR(1g) (W/kg)	Test Plot
		CH	MHz							
GPRS (4Tx slot)	Front	512	1850.2	24.94	25.50	1.14	-	-	-	-
		661	1880.0	24.93	25.50	1.14	0.07	0.066	0.075	-
		810	1909.8	24.52	25.50	1.25	-	-	-	-
	Back	512	1850.2	24.94	25.50	1.14	-	-	-	-
		661	1880.0	24.93	25.50	1.14	-0.10	0.101	0.115	B2
		810	1909.8	24.52	25.50	1.25	-	-	-	-

## Note:

1. Per KDB865664 D01v01r04, Repeated measurement is not required when the original highest measured SAR is < 0.80 W/kg
2. Per KDB 941225 D05v02r03, for QPSK with 100% RB allocation, SAR is not required when the highest maximum output power for 100 % RB allocation is less than the highest maximum output power in 50% and 1 RB allocations and the highest reported SAR for 1 RB and 50% RB allocation are ≤ 0.8 W/kg. Otherwise, SAR is measured for the highest output power channel; and if the reported SAR is > 1.45 W/kg, the remaining required test channels must also be tested.



LTE Band 2										
Mode	Test Position	Frequency		Conducted Power (dBm)	Tune up limit (dBm)	Tune up scaling factor	Power Drift(dB)	Measured SAR(1g) (W/kg)	Report SAR(1g) (W/kg)	Test Plot
		CH	MHz							
<b>Without the TETRA Antenna</b>										
20M_1RB	Front	18700	1860.0	21.72	22.50	1.20	-	-	-	-
		18900	1880.0	21.82	22.50	1.17	-0.05	0.114	0.133	-
		19100	1900.0	21.79	22.50	1.18	-	-	-	-
	Back	18700	1860.0	21.72	22.50	1.20	-	-	-	-
		18900	1880.0	21.82	22.50	1.17	0.11	0.172	0.201	B3
		19100	1900.0	21.79	22.50	1.18	-	-	-	-
20M_50RB	Front	18700	1860.0	20.39	21.00	1.17	-	-	-	-
		18900	1880.0	20.42	21.00	1.17	0.01	0.077	0.088	-
		19100	1900.0	20.22	21.00	1.17	-	-	-	-
	Back	18700	1860.0	20.39	21.00	1.17	-	-	-	-
		18900	1880.0	20.42	21.00	1.15	-0.05	0.117	0.134	-
		19100	1900.0	20.22	21.00	1.14	-	-	-	-
<b>With the TETRA Antenna (only show the worst mode)</b>										
20M_1RB	Back	18700	1860.0	21.72	22.50	1.20	-	-	-	-
		18900	1880.0	21.82	22.50	1.17	0.07	0.163	0.191	-
		19100	1900.0	21.79	22.50	1.18	-	-	-	-

LTE Band 4										
Mode	Test Position	Frequency		Conducted Power (dBm)	Tune up limit (dBm)	Tune up scaling factor	Power Drift(dB)	Measured SAR(1g) (W/kg)	Report SAR(1g) (W/kg)	Test Plot
		CH	MHz							
<b>Without the TETRA Antenna</b>										
20M_1RB	Front	20050	1720	22.25	22.50	1.06	-	-	-	-
		20175	1732.5	22.33	22.50	1.04	0.04	0.160	0.166	-
		20300	1745	22.23	22.50	1.06	-	-	-	-
	Back	20050	1720	22.25	22.50	1.06	-	-	-	-
		20175	1732.5	22.33	22.50	1.04	0.17	0.269	0.280	B4
		20300	1745	22.23	22.50	1.06	-	-	-	-
20M_50RB	Front	20050	1720	20.89	21.50	1.04	-	-	-	-
		20175	1732.5	20.90	21.50	1.04	0.01	0.094	0.108	-
		20300	1745	20.63	21.50	1.04	-	-	-	-
	Back	20050	1720	20.89	21.50	1.04	-	-	-	-
		20175	1732.5	20.90	21.50	1.15	-0.10	0.216	0.248	-
		20300	1745	20.63	21.50	1.15	-	-	-	-
<b>With the TETRA Antenna (only show the worst mode)</b>										
20M_1RB	Back	20050	1720	22.25	22.50	1.06	-	-	-	-
		20175	1732.5	22.33	22.50	1.04	-0.03	0.259	0.269	-
		20300	1745	22.23	22.50	1.06	-	-	-	-

Note:

- Per KDB865664 D01v01r04, Repeated measurement is not required when the original highest measured SAR is < 0.80 W/kg
- Per KDB 941225 D05v02r03, for QPSK with 100% RB allocation, SAR is not required when the highest maximum output power for 100 % RB allocation is less than the highest maximum output power in 50% and 1 RB allocations and the highest reported SAR for 1 RB and 50% RB allocation are ≤ 0.8 W/kg. Otherwise, SAR is measured for the highest output power channel; and if the reported SAR is > 1.45 W/kg, the remaining required test channels must also be tested.

LTE Band 5										
Mode	Test Position	Frequency		Conducted Power (dBm)	Tune up limit (dBm)	Tune up scaling factor	Power Drift(dB)	Measured SAR(1g) (W/kg)	Report SAR(1g) (W/kg)	Test Plot
		CH	MHz							
<b>Without the TETRA Antenna</b>										
10M_1RB	Front	20450	829	22.21	22.50	1.07	-	-	-	-
		20525	836.5	22.23	22.50	1.06	0.06	0.125	0.134	-
		20600	844	22.19	22.50	1.07	-	-	-	-
	Back	20450	829	22.21	22.50	1.07	-	-	-	-
		20525	836.5	22.23	22.50	1.06	-0.10	0.186	0.198	B5
		20600	844	22.19	22.50	1.07	-	-	-	-
10M_25RB	Front	20450	829	20.85	21.00	1.06	-	-	-	-
		20525	836.5	20.81	21.00	1.06	0.02	0.078	0.082	-
		20600	844	20.59	21.00	1.06	-	-	-	-
	Back	20450	829	20.85	21.00	1.06	-	-	-	-
		20525	836.5	20.81	21.00	1.03	-0.03	0.143	0.149	-
		20600	844	20.59	21.00	1.05	-	-	-	-
<b>With the TETRA Antenna (only show the worst mode)</b>										
10M_1RB	Back	20450	829	22.21	22.50	1.07	-	-	-	-
		20525	836.5	22.23	22.50	1.06	0.11	0.184	0.196	-
		20600	844	22.19	22.50	1.07	-	-	-	-

LTE Band 7										
Mode	Test Position	Frequency		Conducted Power (dBm)	Tune up limit (dBm)	Tune up scaling factor	Power Drift(dB)	Measured SAR(1g) (W/kg)	Report SAR(1g) (W/kg)	Test Plot
		CH	MHz							
<b>Without the TETRA Antenna</b>										
20M_1RB	Front	20850	2510	21.51	22.00	1.12	-	-	-	-
		21100	2535	21.59	22.00	1.10	0.03	0.179	0.196	-
		21350	2560	21.52	22.00	1.12	-	-	-	-
	Back	20850	2510	21.51	22.00	1.12	-	-	-	-
		21100	2535	21.59	22.00	1.10	-0.12	0.253	0.278	B6
		21350	2560	21.52	22.00	1.12	-	-	-	-
20M_50RB	Front	20850	2510	20.20	20.50	1.10	-	-	-	-
		21100	2535	20.21	20.50	1.10	0.03	0.127	0.135	-
		21350	2560	19.97	20.50	1.10	-	-	-	-
	Back	20850	2510	20.20	20.50	1.10	-	-	-	-
		21100	2535	20.21	20.50	1.07	-0.12	0.186	0.199	-
		21350	2560	19.97	20.50	1.07	-	-	-	-
<b>With the TETRA Antenna (only show the worst mode)</b>										
20M_1RB	Back	20850	2510	21.51	22.00	1.12	-	-	-	-
		21100	2535	21.59	22.00	1.10	0.05	0.248	0.273	-
		21350	2560	21.52	22.00	1.12	-	-	-	-

## Note:

- Per KDB865664 D01v01r04, Repeated measurement is not required when the original highest measured SAR is < 0.80 W/kg
- Per KDB 941225 D05v02r03, for QPSK with 100% RB allocation, SAR is not required when the highest maximum output power for 100 % RB allocation is less than the highest maximum output power in 50% and 1 RB allocations and the highest reported SAR for 1 RB and 50% RB allocation are ≤ 0.8 W/kg. Otherwise, SAR is measured for the highest output power channel; and if the reported SAR is > 1.45 W/kg, the remaining required test channels must also be tested.

LTE Band 26										
Mode	Test Position	Frequency		Conducted Power (dBm)	Tune up limit (dBm)	Tune up scaling factor	Power Drift(dB)	Measured SAR(1g) (W/kg)	Report SAR(1g) (W/kg)	Test Plot
		CH	MHz							
<b>Without the TETRA Antenna</b>										
15M_1RB	Left-Cheek	26775	822.5	22.67	23.00	1.08	-	-	-	-
		26865	831.5	22.76	23.00	1.06	0.01	0.114	0.121	-
		26965	841.5	22.65	23.00	1.08	-	-	-	-
	Left-Tilt	26775	822.5	22.67	23.00	1.08	-	-	-	-
		26865	831.5	22.76	23.00	1.06	-0.04	0.177	0.187	B7
		26965	841.5	22.65	23.00	1.08	-	-	-	-
15M_36RB	Right-Cheek	26775	822.5	21.29	21.50	1.06	-	-	-	-
		26865	831.5	21.30	21.50	1.06	0.04	0.078	0.082	-
		26965	841.5	21.02	21.50	1.06	-	-	-	-
	Right-Tilt	26775	822.5	21.29	21.50	1.06	-	-	-	-
		26865	831.5	21.30	21.50	1.05	-0.06	0.121	0.127	-
		26965	841.5	21.02	21.50	1.05	-	-	-	-
<b>With the TETRA Antenna (only show the worst mode)</b>										
20M_1RB	Back	26775	822.5	22.67	23.00	1.08	-	-	-	-
		26865	831.5	22.76	23.00	1.06	-0.08	0.171	0.181	-
		26965	841.5	22.65	23.00	1.08	-	-	-	-

Note:

1. Per KDB865664 D01v01r04, Repeated measurement is not required when the original highest measured SAR is < 0.80 W/kg
2. Per KDB 941225 D05v02r03, for QPSK with 100% RB allocation, SAR is not required when the highest maximum output power for 100 % RB allocation is less than the highest maximum output power in 50% and 1 RB allocations and the highest reported SAR for 1 RB and 50% RB allocation are ≤ 0.8 W/kg. Otherwise, SAR is measured for the highest output power channel; and if the reported SAR is > 1.45 W/kg, the remaining required test channels must also be tested.

LTE Band 41											
Mode	Test Position	Frequency		Conducted Power (dBm)	Tune up limit (dBm)	Tune up scaling factor	Duty cycle scaling factor	Power Drift(dB)	Measured SAR(1g) (W/kg)	Report SAR(1g) (W/kg)	Test Plot
		CH	MHz								
<b>Without the TETRA Antenna</b>											
20M_1RB	Front	39750	2506	21.63	22.00	1.09	1.006	-	-	-	-
		40185	2549.5	21.59	22.00	1.10	1.006	-	-	-	-
		40620	2593	21.67	22.00	1.08	1.006	0.05	0.105	0.114	-
		41055	2636.5	21.63	22.00	1.09	1.006	-	-	-	-
	Back	39750	2506	21.63	22.00	1.09	1.006	-	-	-	-
		40185	2549.5	21.59	22.00	1.10	1.006	-	-	-	-
		40620	2593	21.67	22.00	1.08	1.006	-0.15	0.162	0.176	B8
		41055	2636.5	21.63	22.00	1.09	1.006	-	-	-	-
20M_50RB	Front	39750	2506	20.66	21.00	1.08	1.006	-	-	-	-
		40185	2549.5	20.82	21.00	1.04	1.006	-	-	-	-
		40620	2593	20.84	21.00	1.04	1.006	0.06	0.089	0.093	-
		41055	2636.5	20.80	21.00	1.05	1.006	-	-	-	-
	Back	41490	2680	20.68	21.00	1.08	1.006	-	-	-	-
		39750	2506	20.66	21.00	1.08	1.006	-	-	-	-
		40185	2549.5	20.82	21.00	1.04	1.006	-	-	-	-
		40620	2593	20.84	21.00	1.04	1.006	-0.10	0.116	0.122	-
41055	2636.5	20.80	21.00	1.05	1.006	-	-	-	-		
41490	2680	20.68	21.00	1.08	1.006	-	-	-	-		
<b>With the TETRA Antenna (only show the worst mode)</b>											
20M_1RB	Back	39750	2506	21.63	22.00	1.09	1.006	-	-	-	-
		40185	2549.5	21.59	22.00	1.10	1.006	-	-	-	-
		40620	2593	21.67	22.00	1.08	1.006	0.05	0.149	0.162	-
		41055	2636.5	21.63	22.00	1.09	1.006	-	-	-	-
		41490	2680	21.62	22.00	1.09	1.006	-	-	-	-

WLAN										
Mode	Test Position	Frequency		Conducted Power (dBm)	Tune up limit (dBm)	Tune up scaling factor	Power Drift(dB)	Measured SAR(1g) (W/kg)	Report SAR(1g) (W/kg)	Test Plot
		CH	MHz							
<b>Without the TETRA Antenna</b>										
802.11b 1Mbps	Front	1	2412	10.74	11.50	1.19	-	-	-	-
		6	2437	11.37	11.50	1.03	0.09	0.091	0.094	-
		11	2462	10.74	11.50	1.19	-	-	-	-
	Back	1	2412	10.74	11.50	1.19	-	-	-	-
		6	2437	11.37	11.50	1.03	-0.19	0.134	0.138	B9
		11	2462	10.74	11.50	1.19	-	-	-	-
<b>With the TETRA Antenna (only show the worst mode)</b>										
802.11b 1Mbps	Back	1	2412	10.74	11.50	1.19	-	-	-	-
		6	2437	11.37	11.50	1.03	0.07	0.129	0.133	-
		11	2462	10.74	11.50	1.19	-	-	-	-

Note:

- According to the above table, the initial test position for body is "Back", and its reported SAR is  $\leq 0.4$ W/kg. Thus further SAR measurement is not required for the other (remaining) test positions. Because the reported SAR of the highest measured maximum output power channel for the exposure configuration is  $\leq 0.8$ W/kg, no further SAR testing is required for 802.11b DSSS in that exposure configuration.
- When SAR measurement is required for 2.4 GHz 802.11g/n OFDM configurations, the measurement and test reduction procedures for OFDM are applied. SAR is not required for the following 2.4 GHz OFDM conditions.
  - When KDB Publication 447498 D01 SAR test exclusion applies to the OFDM configuration.
  - When the highest *reported* SAR for DSSS is adjusted by the ratio of OFDM to DSSS specified maximum output power and the adjusted SAR is  $\leq 1.2$  W/kg, the 802.11g/n is not required.

WLAN- Scaled Reported SAR							
Mode	Test Position	Frequency		Actual duty factor	maximum duty factor	Reported SAR (1g)(W/kg)	Scaled reported SAR (1g)(W/kg)
		CH	MHz				
<b>Without the TETRA Antenna</b>							
802.11b 1Mbps	Front	6	2437	95.84%	100%	0.094	0.098
	Back	6	2437	95.84%	100%	0.138	0.144
<b>With the TETRA Antenna (only show the worst mode)</b>							
802.11b 1Mbps	Back	6	2437	95.84%	100%	0.133	0.139

Note:

- According to the KDB248227 D01, The reported SAR must be scaled to 100% transmission duty factor to determine compliance at the maximum tune-up tolerance limit. A maximum transmission duty factor of 98.96% is achievable for WLAN in this project.

**Hotspot SAR**

Positions for SAR tests; Hotspot mode						
Antenna	Back	Front	Top side	Bottom side	Right side	Left side
WWAN	Yes	Yes	No	Yes	Yes	Yes
WIFI / BT	Yes	Yes	Yes	No	Yes	Yes

General note:

Referring to KDB941225 D06, when the overall device length and width are >9cm\*5cm, the test distance is 10mm. SAR must be measured for all sides and surfaces with a transmitting antenna located within 25mm from that surface or edge.

GSM850										
Mode	Test Position	Frequency		Conducted Power (dBm)	Tune up limit (dBm)	Tune up scaling factor	Power Drift(dB)	Measured SAR(1g) (W/kg)	Report SAR(1g) (W/kg)	Test Plot
		CH	MHz							
GPRS (4Tx slot)	Front	128	824.2	28.02	28.50	1.12	-	-	-	-
		190	836.6	28.11	28.50	1.09	-0.02	0.119	0.130	-
		251	848.8	27.91	28.50	1.15	-	-	-	-
	Back	128	824.2	28.02	28.50	1.12	-	-	-	-
		190	836.6	28.11	28.50	1.09	0.05	0.180	0.197	B1
		251	848.8	27.91	28.50	1.15	-	-	-	-
	Left	190	836.6	28.11	28.50	1.09	-0.03	0.082	0.090	-
	Right	190	836.6	28.11	28.50	1.09	0.02	0.078	0.085	-
	Top	190	836.6	28.11	28.50	1.09	-	-	-	-
Bottom	190	836.6	28.11	28.50	1.09	0.07	0.123	0.134	-	

PCS1900										
Mode	Test Position	Frequency		Conducted Power (dBm)	Tune up limit (dBm)	Tune up scaling factor	Power Drift(dB)	Measured SAR(1g) (W/kg)	Report SAR(1g) (W/kg)	Test Plot
		CH	MHz							
GPRS (4Tx slot)	Front	512	1850.2	24.94	25.50	1.14	-	-	-	-
		661	1880.0	24.93	25.50	1.14	0.07	0.066	0.075	-
		810	1909.8	24.52	25.50	1.25	-	-	-	-
	Back	512	1850.2	24.94	25.50	1.14	-	-	-	-
		661	1880.0	24.93	25.50	1.14	-0.10	0.101	0.115	B2
		810	1909.8	24.52	25.50	1.25	-	-	-	-
	Left	661	1880.0	24.93	25.50	1.14	0.05	0.058	0.066	-
	Right	661	1880.0	24.93	25.50	1.14	0.03	0.046	0.052	-
	Top	661	1880.0	24.93	25.50	1.14	-	-	-	-
Bottom	661	1880.0	24.93	25.50	1.14	-0.10	0.069	0.079	-	

Note:

- Per KDB865664 D01v01r04, Repeated measurement is not required when the original highest measured SAR is < 0.80 W/kg

LTE Band 2										
Mode	Test Position	Frequency		Conducted Power (dBm)	Tune up limit (dBm)	Tune up scaling factor	Power Drift(dB)	Measured SAR(1g) (W/kg)	Report SAR(1g) (W/kg)	Test Plot
		CH	MHz							
20M_1RB	Front	18700	1860.0	21.72	22.50	1.20	-	-	-	-
		18900	1880.0	21.82	22.50	1.17	-0.05	0.114	0.133	-
		19100	1900.0	21.79	22.50	1.18	-	-	-	-
	Back	18700	1860.0	21.72	22.50	1.20	-	-	-	-
		18900	1880.0	21.82	22.50	1.17	0.11	0.172	0.201	B3
		19100	1900.0	21.79	22.50	1.18	-	-	-	-
	Left	18900	1880.0	21.82	22.50	1.17	-0.06	0.096	0.112	-
	Right	18900	1880.0	21.82	22.50	1.17	0.04	0.078	0.091	-
	Top	18900	1880.0	21.82	22.50	1.17	-	-	-	-
Bottom	18900	1880.0	21.82	22.50	1.17	0.13	0.125	0.146	-	
20M_50RB	Front	18700	1860.0	20.39	21.00	1.15	-	-	-	-
		18900	1880.0	20.42	21.00	1.14	0.01	0.077	0.088	-
		19100	1900.0	20.22	21.00	1.20	-	-	-	-
	Back	18700	1860.0	20.39	21.00	1.15	-	-	-	-
		18900	1880.0	20.42	21.00	1.14	-0.05	0.117	0.134	-
		19100	1900.0	20.22	21.00	1.20	-	-	-	-
	Left	18900	1880.0	20.42	21.00	1.14	0.01	0.067	0.077	-
	Right	18900	1880.0	20.42	21.00	1.14	0.01	0.053	0.060	-
	Top	18900	1880.0	20.42	21.00	1.14	-	-	-	-
Bottom	18900	1880.0	20.42	21.00	1.14	-0.05	0.086	0.098	-	

LTE Band 4										
Mode	Test Position	Frequency		Conducted Power (dBm)	Tune up limit (dBm)	Tune up scaling factor	Power Drift(dB)	Measured SAR(1g) (W/kg)	Report SAR(1g) (W/kg)	Test Plot
		CH	MHz							
20M_1RB	Front	20050	1720	22.25	22.50	1.06	-	-	-	-
		20175	1732.5	22.33	22.50	1.04	0.04	0.160	0.166	-
		20300	1745	22.23	22.50	1.06	-	-	-	-
	Back	20050	1720	22.25	22.50	1.06	-	-	-	-
		20175	1732.5	22.33	22.50	1.04	0.17	0.269	0.280	B4
		20300	1745	22.23	22.50	1.06	-	-	-	-
	Left	20175	1732.5	22.33	22.50	1.04	-0.13	0.153	0.160	-
	Right	20175	1732.5	22.33	22.50	1.04	0.02	0.110	0.115	-
	Top	20175	1732.5	22.33	22.50	1.04	-	-	-	-
Bottom	20175	1732.5	22.33	22.50	1.04	0.06	0.174	0.181	-	
20M_50RB	Front	20050	1720	20.89	21.50	1.15	-	-	-	-
		20175	1732.5	20.90	21.50	1.15	0.01	0.094	0.108	-
		20300	1745	20.63	21.50	1.22	-	-	-	-
	Back	20050	1720	20.89	21.50	1.15	-	-	-	-
		20175	1732.5	20.90	21.50	1.15	-0.10	0.216	0.248	-
		20300	1745	20.63	21.50	1.22	-	-	-	-
	Left	20175	1732.5	20.90	21.50	1.15	0.07	0.123	0.141	-
	Right	20175	1732.5	20.90	21.50	1.15	-0.01	0.095	0.109	-
	Top	20175	1732.5	20.90	21.50	1.15	-	-	-	-
Bottom	20175	1732.5	20.90	21.50	1.15	-0.02	0.143	0.164	-	



LTE Band 5										
Mode	Test Position	Frequency		Conducted Power (dBm)	Tune up limit (dBm)	Tune up scaling factor	Power Drift(dB)	Measured SAR(1g) (W/kg)	Report SAR(1g) (W/kg)	Test Plot
		CH	MHz							
10M_1RB	Front	20450	829	22.21	22.50	1.07	-	-	-	-
		20525	836.5	22.23	22.50	1.06	0.06	0.125	0.134	-
		20600	844	22.19	22.50	1.07	-	-	-	-
	Back	20450	829	22.21	22.50	1.07	-	-	-	-
		20525	836.5	22.23	22.50	1.06	-0.10	0.186	0.198	B5
		20600	844	22.19	22.50	1.07	-	-	-	-
	Left	20525	836.5	22.23	22.50	1.06	0.04	0.106	0.113	-
	Right	20525	836.5	22.23	22.50	1.06	-0.04	0.081	0.086	-
	Top	20525	836.5	22.23	22.50	1.06	-	-	-	-
Bottom	20525	836.5	22.23	22.50	1.06	-0.06	0.113	0.120	-	
10M_25RB	Front	20450	829	20.85	21.00	1.03	-	-	-	-
		20525	836.5	20.81	21.00	1.05	0.02	0.078	0.082	-
		20600	844	20.59	21.00	1.10	-	-	-	-
	Back	20450	829	20.85	21.00	1.03	-	-	-	-
		20525	836.5	20.81	21.00	1.05	-0.03	0.143	0.149	-
		20600	844	20.59	21.00	1.10	-	-	-	-
	Left	20525	836.5	20.81	21.00	1.05	0.02	0.081	0.085	-
	Right	20525	836.5	20.81	21.00	1.05	-0.01	0.062	0.065	-
	Top	20525	836.5	20.81	21.00	1.05	-	-	-	-
Bottom	20525	836.5	20.81	21.00	1.05	0.00	0.094	0.098	-	

## Note:

1. Per KDB865664 D01v01r04, Repeated measurement is not required when the original highest measured SAR is < 0.80 W/kg
2. Per KDB 941225 D05v02r03, for QPSK with 100% RB allocation, SAR is not required when the highest maximum output power for 100 % RB allocation is less than the highest maximum output power in 50% and 1 RB allocations and the highest reported SAR for 1 RB and 50% RB allocation are ≤ 0.8 W/kg. Otherwise, SAR is measured for the highest output power channel; and if the reported SAR is > 1.45 W/kg, the remaining required test channels must also be tested.

LTE Band 7										
Mode	Test Position	Frequency		Conducted Power (dBm)	Tune up limit (dBm)	Tune up scaling factor	Power Drift(dB)	Measured SAR(1g) (W/kg)	Report SAR(1g) (W/kg)	Test Plot
		CH	MHz							
20M_1RB	Front	20850	2510	21.51	22.00	1.12	-	-	-	-
		21100	2535	21.59	22.00	1.10	0.03	0.179	0.196	-
		21350	2560	21.52	22.00	1.12	-	-	-	-
	Back	20850	2510	21.51	22.00	1.12	-	-	-	-
		21100	2535	21.59	22.00	1.10	-0.12	0.253	0.278	B6
		21350	2560	21.52	22.00	1.12	-	-	-	-
	Left	21100	2535	21.59	22.00	1.10	0.04	0.152	0.168	-
	Right	21100	2535	21.59	22.00	1.10	-0.03	0.135	0.149	-
	Top	21100	2535	21.59	22.00	1.10	-	-	-	-
Bottom	21100	2535	21.59	22.00	1.10	-0.03	0.137	0.150	-	
20M_50RB	Front	20850	2510	20.20	20.50	1.07	-	-	-	-
		21100	2535	20.21	20.50	1.07	0.03	0.127	0.135	-
		21350	2560	19.97	20.50	1.13	-	-	-	-
	Back	20850	2510	20.20	20.50	1.07	-	-	-	-
		21100	2535	20.21	20.50	1.07	-0.12	0.186	0.199	-
		21350	2560	19.97	20.50	1.13	-	-	-	-
	Left	21100	2535	20.21	20.50	1.07	0.03	0.098	0.104	-
	Right	21100	2535	20.21	20.50	1.07	-0.04	0.093	0.099	-
	Top	21100	2535	20.21	20.50	1.07	-	-	-	-
Bottom	21100	2535	20.21	20.50	1.07	-0.16	0.103	0.110	-	

## Note:

1. Per KDB865664 D01v01r04, Repeated measurement is not required when the original highest measured SAR is < 0.80 W/kg
2. Per KDB 941225 D05v02r03, for QPSK with 100% RB allocation, SAR is not required when the highest maximum output power for 100 % RB allocation is less than the highest maximum output power in 50% and 1 RB allocations and the highest reported SAR for 1 RB and 50% RB allocation are  $\leq 0.8$  W/kg. Otherwise, SAR is measured for the highest output power channel; and if the reported SAR is > 1.45 W/kg, the remaining required test channels must also be tested.

LTE Band 26										
Mode	Test Position	Frequency		Conducted Power (dBm)	Tune up limit (dBm)	Tune up scaling factor	Power Drift(dB)	Measured SAR(1g) (W/kg)	Report SAR(1g) (W/kg)	Test Plot
		CH	MHz							
15M_1RB	Front	26775	822.5	22.67	23.00	1.08	-	-	-	-
		26865	831.5	22.76	23.00	1.06	0.01	0.114	0.121	-
		26965	841.5	22.65	23.00	1.08	-	-	-	-
	Back	26775	822.5	22.67	23.00	1.08	-	-	-	-
		26865	831.5	22.76	23.00	1.06	-0.04	0.177	0.187	B7
		26965	841.5	22.65	23.00	1.08	-	-	-	-
	Left	26865	831.5	22.76	23.00	1.06	0.02	0.090	0.095	-
	Right	26865	831.5	22.76	23.00	1.06	-0.01	0.086	0.090	-
	Top	26865	831.5	22.76	23.00	1.06	-	-	-	-
Bottom	26865	831.5	22.76	23.00	1.06	-0.03	0.100	0.106	-	
15M_36RB	Front	26775	822.5	21.29	21.50	1.05	-	-	-	-
		26865	831.5	21.30	21.50	1.05	0.04	0.078	0.082	-
		26965	841.5	21.02	21.50	1.12	-	-	-	-
	Back	26775	822.5	21.29	21.50	1.05	-	-	-	-
		26865	831.5	21.30	21.50	1.05	-0.06	0.121	0.127	-
		26965	841.5	21.02	21.50	1.12	-	-	-	-
	Left	26865	831.5	21.30	21.50	1.05	0.05	0.073	0.077	-
	Right	26865	831.5	21.30	21.50	1.05	-0.02	0.065	0.068	-
	Top	26865	831.5	21.30	21.50	1.05	-	-	-	-
Bottom	26865	831.5	21.30	21.50	1.05	-0.01	0.070	0.073	-	

## Note:

1. Per KDB865664 D01v01r04, Repeated measurement is not required when the original highest measured SAR is < 0.80 W/kg
2. Per KDB 941225 D05v02r03, for QPSK with 100% RB allocation, SAR is not required when the highest maximum output power for 100 % RB allocation is less than the highest maximum output power in 50% and 1 RB allocations and the highest reported SAR for 1 RB and 50% RB allocation are  $\leq 0.8$  W/kg. Otherwise, SAR is measured for the highest output power channel; and if the reported SAR is > 1.45 W/kg, the remaining required test channels must also be tested.

LTE Band 41											
Mode	Test Position	Frequency		Conducted Power (dBm)	Tune up limit (dBm)	Tune up scaling factor	Duty cycle scaling factor	Power Drift(dB)	Measured SAR(1g) (W/kg)	Report SAR(1g) (W/kg)	Test Plot
		CH	MHz								
20M_1RB	Front	39750	2506	21.63	22.00	1.09	1.006	-	-	-	-
		40185	2549.5	21.59	22.00	1.10	1.006	-	-	-	-
		40620	2593	21.67	22.00	1.08	1.006	0.05	0.105	0.114	-
		41055	2636.5	21.63	22.00	1.09	1.006	-	-	-	-
		41490	2680	21.62	22.00	1.09	1.006	-	-	-	-
	Back	39750	2506	21.63	22.00	1.09	1.006	-	-	-	-
		40185	2549.5	21.59	22.00	1.10	1.006	-	-	-	-
		40620	2593	21.67	22.00	1.08	1.006	-0.15	0.162	0.1765	B8
		41055	2636.5	21.63	22.00	1.09	1.006	-	-	-	-
		41490	2680	21.62	22.00	1.09	1.006	-	-	-	-
	Left	40620	2593	21.67	22.00	1.08	1.006	0.08	0.089	0.096	-
	Right	40620	2593	21.67	22.00	1.08	1.006	-0.05	0.083	0.090	-
	Top	40620	2593	21.67	22.00	1.08	1.006	-	-	-	-
	Bottom	40620	2593	21.67	22.00	1.08	1.006	-0.10	0.092	0.099	-
20M_50RB	Front	39750	2506	20.66	21.00	1.08	1.006	-	-	-	-
		40185	2549.5	20.82	21.00	1.04	1.006	-	-	-	-
		40620	2593	20.84	21.00	1.04	1.006	0.06	0.089	0.093	-
		41055	2636.5	20.80	21.00	1.05	1.006	-	-	-	-
		41490	2680	20.68	21.00	1.08	1.006	-	-	-	-
	Back	39750	2506	20.66	21.00	1.08	1.006	-	-	-	-
		40185	2549.5	20.82	21.00	1.04	1.006	-	-	-	-
		40620	2593	20.84	21.00	1.04	1.006	-0.10	0.116	0.122	-
		41055	2636.5	20.80	21.00	1.05	1.006	-	-	-	-
		41490	2680	20.68	21.00	1.08	1.006	-	-	-	-
	Left	40620	2593	20.84	21.00	1.04	1.006	0.08	0.070	0.074	-
	Right	40620	2593	20.84	21.00	1.04	1.006	-0.04	0.065	0.069	-
	Top	40620	2593	20.84	21.00	1.04	1.006	-	-	-	-
	Bottom	40620	2593	20.84	21.00	1.04	1.006	-0.01	0.067	0.070	-

Note:

- Per KDB865664 D01v01r04, Repeated measurement is not required when the original highest measured SAR is < 0.80 W/kg
- Per KDB 941225 D05v02r03, for QPSK with 100% RB allocation, SAR is not required when the highest maximum output power for 100 % RB allocation is less than the highest maximum output power in 50% and 1 RB allocations and the highest reported SAR for 1 RB and 50% RB allocation are ≤ 0.8 W/kg. Otherwise, SAR is measured for the highest output power channel; and if the reported SAR is > 1.45 W/kg, the remaining required test channels must also be tested.

WLAN										
Mode	Test Position	Frequency		Conducted Power (dBm)	Tune up limit (dBm)	Tune up scaling factor	Power Drift(dB)	Measured SAR(1g) (W/kg)	Report SAR(1g) (W/kg)	Test Plot
		CH	MHz							
802.11b 1Mbps	Front	1	2412	10.74	11.50	1.19	-	-	-	-
		6	2437	11.37	11.50	1.03	0.09	0.091	0.094	-
		11	2462	10.74	11.50	1.19	-	-	-	-
	Back	1	2412	10.74	11.50	1.19	-	-	-	-
		6	2437	11.37	11.50	1.03	-0.19	0.134	0.138	B9
		11	2462	10.74	11.50	1.19	-	-	-	-
	Left	6	2437	10.74	11.50	1.19	-0.14	0.051	0.061	-
	Right	6	2437	10.74	11.50	1.19	-0.04	0.044	0.053	-
	Top	6	2437	10.74	11.50	1.19	0.06	0.076	0.090	-
Bottom	6	2437	10.74	11.50	1.19	-	-	-	-	

Note:

- According to the above table, the initial test position for body is "Back", and its reported SAR is  $\leq 0.4$ W/kg. Thus further SAR measurement is not required for the other (remaining) test positions. Because the reported SAR of the highest measured maximum output power channel for the exposure configuration is  $\leq 0.8$ W/kg, no further SAR testing is required for 802.11b DSSS in that exposure configuration.
- When SAR measurement is required for 2.4 GHz 802.11g/n OFDM configurations, the measurement and test reduction procedures for OFDM are applied. SAR is not required for the following 2.4 GHz OFDM conditions.
  - When KDB Publication 447498 D01 SAR test exclusion applies to the OFDM configuration.
  - When the highest *reported* SAR for DSSS is adjusted by the ratio of OFDM to DSSS specified maximum output power and the adjusted SAR is  $\leq 1.2$  W/kg. the 802.11g/n is not required

WLAN- Scaled Reported SAR							
Mode	Test Position	Frequency		Actual duty factor	maximum duty factor	Reported SAR (1g)(W/kg)	Scaled reported SAR (1g)(W/kg)
		CH	MHz				
802.11b 1Mbps	Front	6	2437	98.96%	100%	0.094	0.095
	Back	6	2437	98.96%	100%	0.138	0.139
	Left	6	2437	98.96%	100%	0.061	0.062
	Right	6	2437	98.96%	100%	0.053	0.053
	Top	6	2437	98.96%	100%	0.090	0.091

Note:

- According to the KDB248227 D01, The reported SAR must be scaled to 100% transmission duty factor to determine compliance at the maximum tune-up tolerance limit. A maximum transmission duty factor of 98.96% is achievable for WLAN in this project.

#### SAR Test Data Plots

Test Plot:

TF

Test Position:

Front of Face

Date: 2017-06-16

Communication System: Customer System; Frequency: 460.0MHz;  
Medium parameters used (interpolated):  $f = 460.00\text{MHz}$ ;  $\sigma = 0.89\text{ S/m}$ ;  $\epsilon_r = 43.46$ ;  $\rho = 1000\text{ kg/m}^3$   
Phantom section : Flat Section

**DASY5 Configuration:**

- Probe: ES3DV3 - SN3292; ConvF(7.12, 7.12, 7.12); Calibrated: 02/09/2016;
- Sensor-Surface: 4mm (Mechanical Surface Detection)
- Electronics: DAE4 Sn1315; Calibrated: 26/07/2016
- Phantom: ELI v4.0; Type: QDOVA001BB
- Measurement SW: DASY52, Version 52.8 (2); SEMCAD X Version 14.6.6 (6824)

**Area Scan(61x101x1):** Interpolated grid:  $dx=1.500\text{ mm}$ ,  $dy=1.500\text{ mm}$   
Maximum value of SAR (interpolated) =2.99 W/kg

**Zoom Scan (5x5x6)/Cube 0:** Measurement grid:  $dx=7\text{mm}$ ,  $dy=7\text{mm}$ ,  $dz=5\text{mm}$   
Reference Value = 53.561 V/m; Power Drift = -0.07 dB  
Peak SAR (extrapolated) = 3.563 mW/g  
**SAR(1 g) = 2.68 mW/g; SAR(10 g) = 1.99 mW/g**  
Maximum value of SAR (measured) = 2.82 W/kg

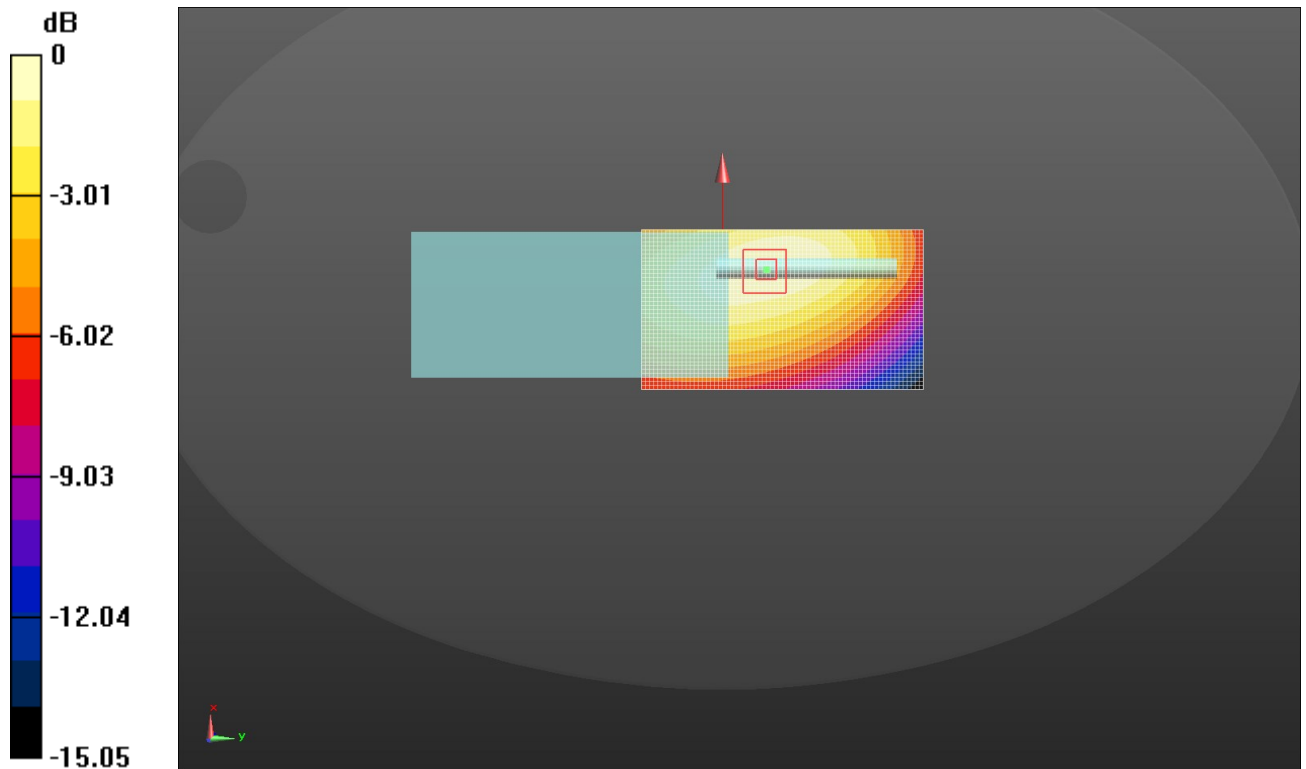

Test Plot:	DF	Test Position:	Front of Face
------------	----	----------------	---------------

Date: 2017-06-16

Communication System: Customer System; Frequency: 460.0 MHz;

Medium parameters used (interpolated):  $f = 460.00\text{MHz}$ ;  $\sigma = 0.89\text{ S/m}$ ;  $\epsilon_r = 43.46$ ;  $\rho = 1000\text{ kg/m}^3$ 

Phantom section : Flat Section

**DASY5 Configuration:**

- Probe: ES3DV3 - SN3292; ConvF(7.12, 7.12, 7.12); Calibrated: 02/09/2016;
- Sensor-Surface: 4mm (Mechanical Surface Detection)
- Electronics: DAE4 Sn1315; Calibrated: 26/07/2016
- Phantom: ELI v4.0; Type: QDOVA001BB
- Measurement SW: DASY52, Version 52.8 (2); SEMCAD X Version 14.6.6 (6824)

**Area Scan(61x101x1):** Interpolated grid:  $dx=1.500\text{ mm}$ ,  $dy=1.500\text{ mm}$ 

Maximum value of SAR (interpolated) = 2.87 W/kg

**Zoom Scan (5x5x6)/Cube 0:** Measurement grid:  $dx=7\text{mm}$ ,  $dy=7\text{mm}$ ,  $dz=5\text{mm}$ 

Reference Value = 53.126 V/m; Power Drift = 0.06 dB

Peak SAR (extrapolated) = 3.665 mW/g

**SAR(1 g) = 2.75 mW/g; SAR(10 g) = 2.03 mW/g**

Maximum value of SAR (measured) = 2.88 W/kg

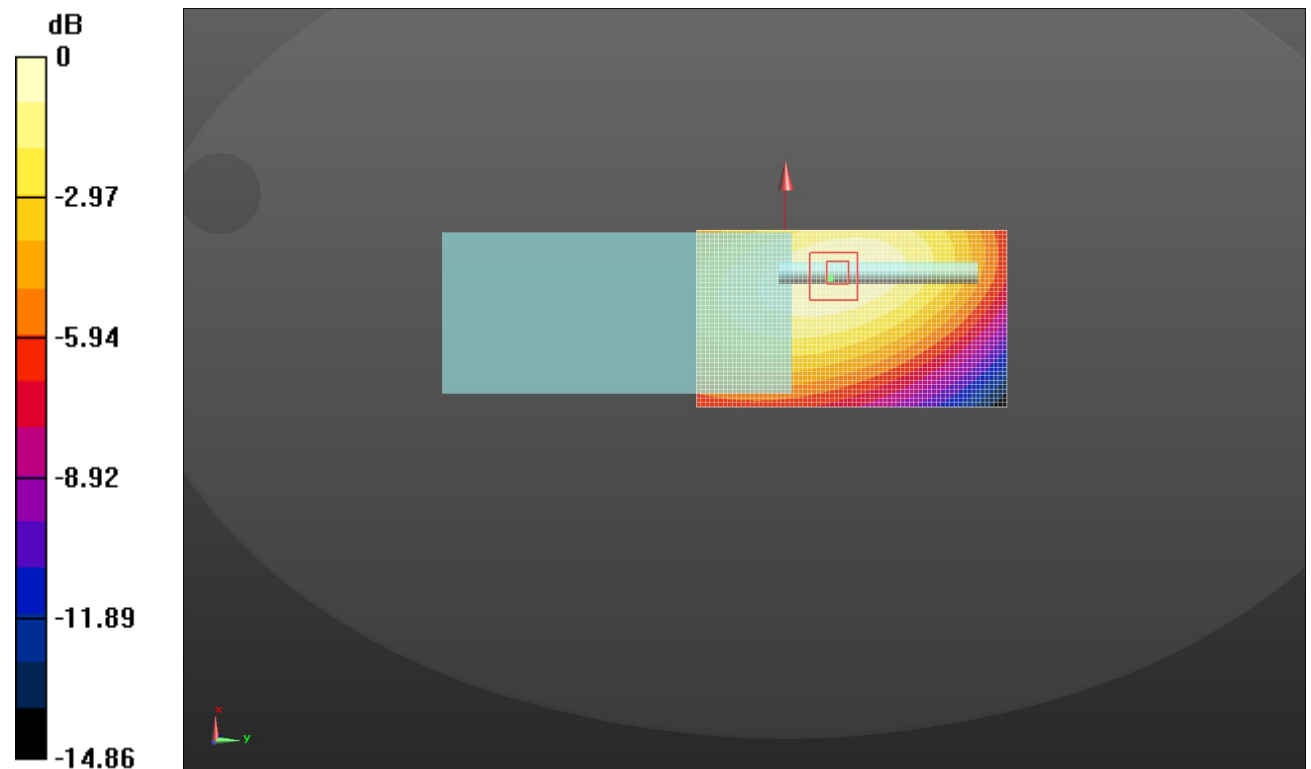

Test Plot:	TB	Test Position:	Body-worn
------------	----	----------------	-----------

Date: 2017-06-20

Communication System: Customer System; Frequency: 460.0 MHz;

Medium parameters used (interpolated):  $f = 460.00\text{MHz}$ ;  $\sigma = 0.95\text{ S/m}$ ;  $\epsilon_r = 56.31$ ;  $\rho = 1000\text{ kg/m}^3$

Phantom section : Flat Section

**DASY5 Configuration:**

- Probe: ES3DV3 - SN3292; ConvF(7.33, 7.33, 7.33); Calibrated: 02/09/2016;
- Sensor-Surface: 4mm (Mechanical Surface Detection)
- Electronics: DAE4 Sn1315; Calibrated: 26/07/2016
- Phantom: ELI v4.0; Type: QDOVA001BB
- Measurement SW: DASY52, Version 52.8 (2); SEMCAD X Version 14.6.6 (6824)

**Area Scan(61x101x1):** Interpolated grid:  $dx=1.500\text{ mm}$ ,  $dy=1.500\text{ mm}$   
 Maximum value of SAR (interpolated) = 3.61 W/kg

**Zoom Scan (5x5x6)/Cube 0:** Measurement grid:  $dx=7\text{mm}$ ,  $dy=7\text{mm}$ ,  $dz=5\text{mm}$   
 Reference Value = 69.659 V/m; Power Drift = 0.10 dB  
 Peak SAR (extrapolated) = 4.127 mW/g  
**SAR(1 g) = 3.56 mW/g; SAR(10 g) = 2.13 mW/g**  
 Maximum value of SAR (measured) = 3.65 W/kg

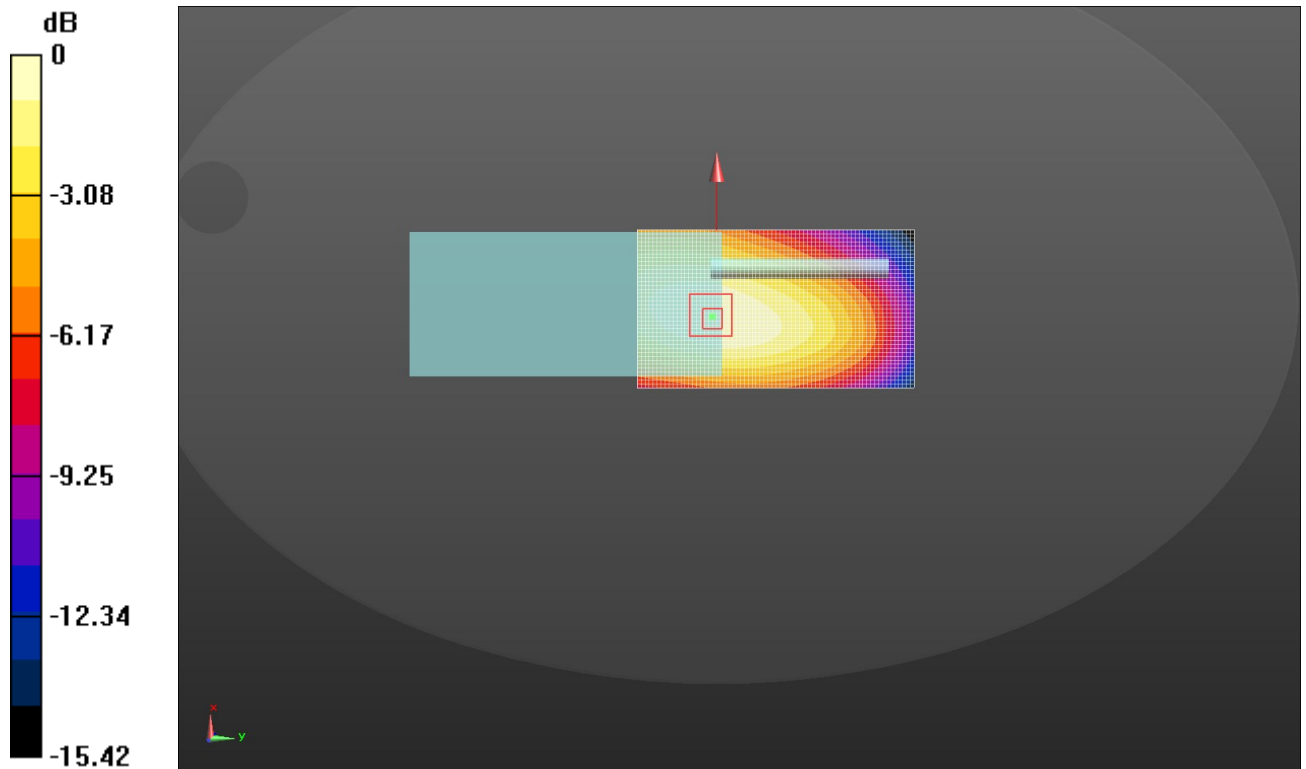



Test Plot:	DB	Test Position:	Body-worn
------------	----	----------------	-----------

Date: 2017-06-20

Communication System: Customer System; Frequency: 460.0 MHz;

Medium parameters used (interpolated):  $f = 460.00\text{MHz}$ ;  $\sigma = 0.95\text{ S/m}$ ;  $\epsilon_r = 56.31$ ;  $\rho = 1000\text{ kg/m}^3$

Phantom section : Flat Section

**DASY5 Configuration:**

- Probe: ES3DV3 - SN3292; ConvF(7.33, 7.33, 7.33); Calibrated: 02/09/2016;
- Sensor-Surface: 4mm (Mechanical Surface Detection)
- Electronics: DAE4 Sn1315; Calibrated: 26/07/2016
- Phantom: ELI v4.0; Type: QDOVA001BB
- Measurement SW: DASY52, Version 52.8 (2); SEMCAD X Version 14.6.6 (6824)

**Area Scan(61x101x1):** Interpolated grid:  $dx=1.500\text{ mm}$ ,  $dy=1.500\text{ mm}$

Maximum value of SAR (interpolated) =3.79W/kg

**Zoom Scan (5x5x6)/Cube 0:** Measurement grid:  $dx=7\text{mm}$ ,  $dy=7\text{mm}$ ,  $dz=5\text{mm}$

Reference Value = 66.985 V/m; Power Drift = 0.16 dB

Peak SAR (extrapolated) = 4.328 mW/g

**SAR(1 g) = 3.72 mW/g; SAR(10 g) = 2.55 mW/g**

Maximum value of SAR (measured) =3.81 W/kg

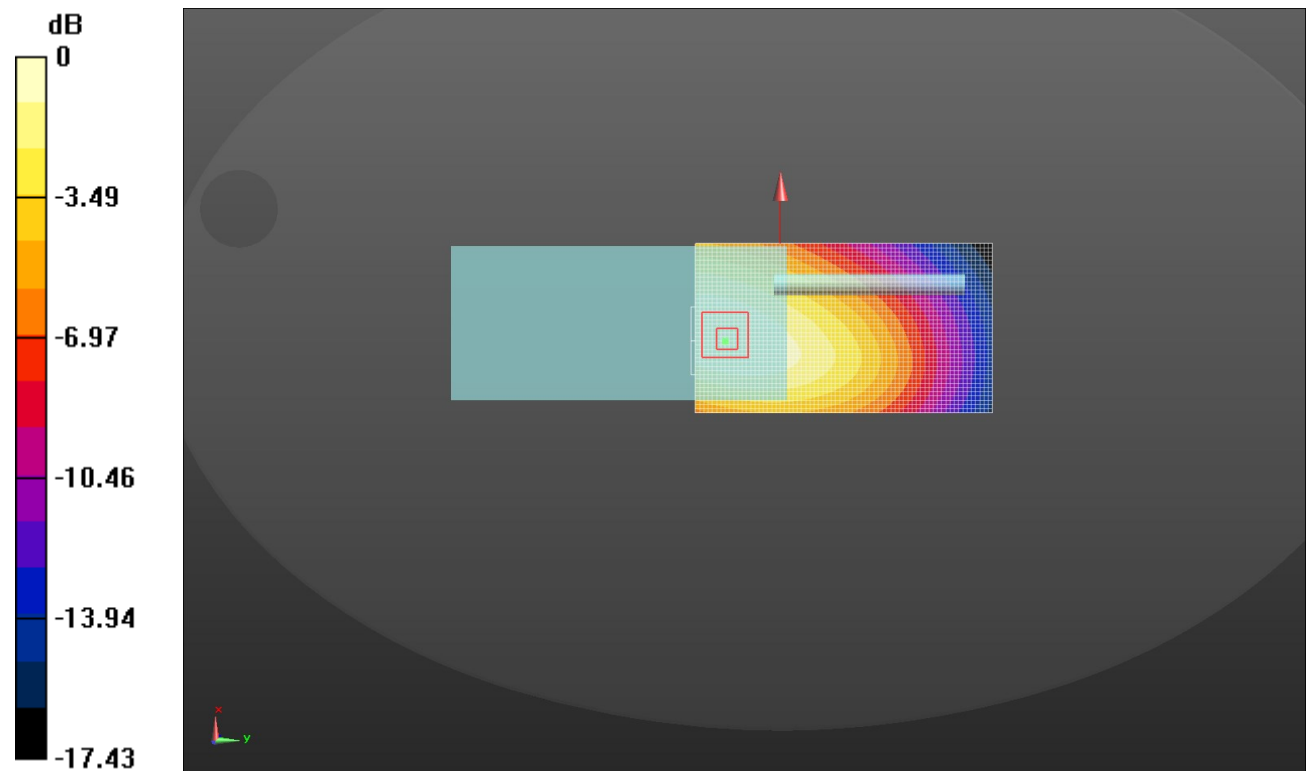

Test mode: GSM850-GPRS 4TS Test Position: Left Head Cheek Test Plot: H1

Date: 2017-05-20

Communication System: Customer System; Frequency: 836.6 MHz; Duty Cycle:1:2

Medium parameters used (interpolated):  $f=836.6$  MHz;  $\sigma=0.92$ s/m;  $\epsilon_r=41.62$ ;  $\rho=1000$  kg/m<sup>3</sup>

Phantom section: Left Section

DASY5 Configuration:

- Probe: ES3DV3 - SN3292; ConvF(6.53, 6.53, 6.53);
- Sensor-Surface: 4mm (Mechanical Surface Detection)
- Electronics: DAE4 Sn1315; Calibrated: 2016/7/26
- Phantom: SAM 1; Type: SAM;
- Measurement SW: DASY52, Version 52.8 (2); SEMCAD X Version 14.6.6 (6824)

**Area Scan (71x121x1):** Interpolated grid:  $dx=1.500$  mm,  $dy=1.500$  mm

Maximum value of SAR (interpolated) = 0.373 W/kg

**Zoom Scan (7x7x7)/Cube 0:** Measurement grid:  $dx=5$ mm,  $dy=5$ mm,  $dz=5$ mm

Reference Value = 12.836 V/m; Power Drift = -0.03 dB

Peak SAR (extrapolated) = 0.458 mW/g

**SAR(1 g) = 0.367 mW/g; SAR(10 g) = 0.270 mW/g**

Maximum value of SAR (measured) = 0.388 W/kg

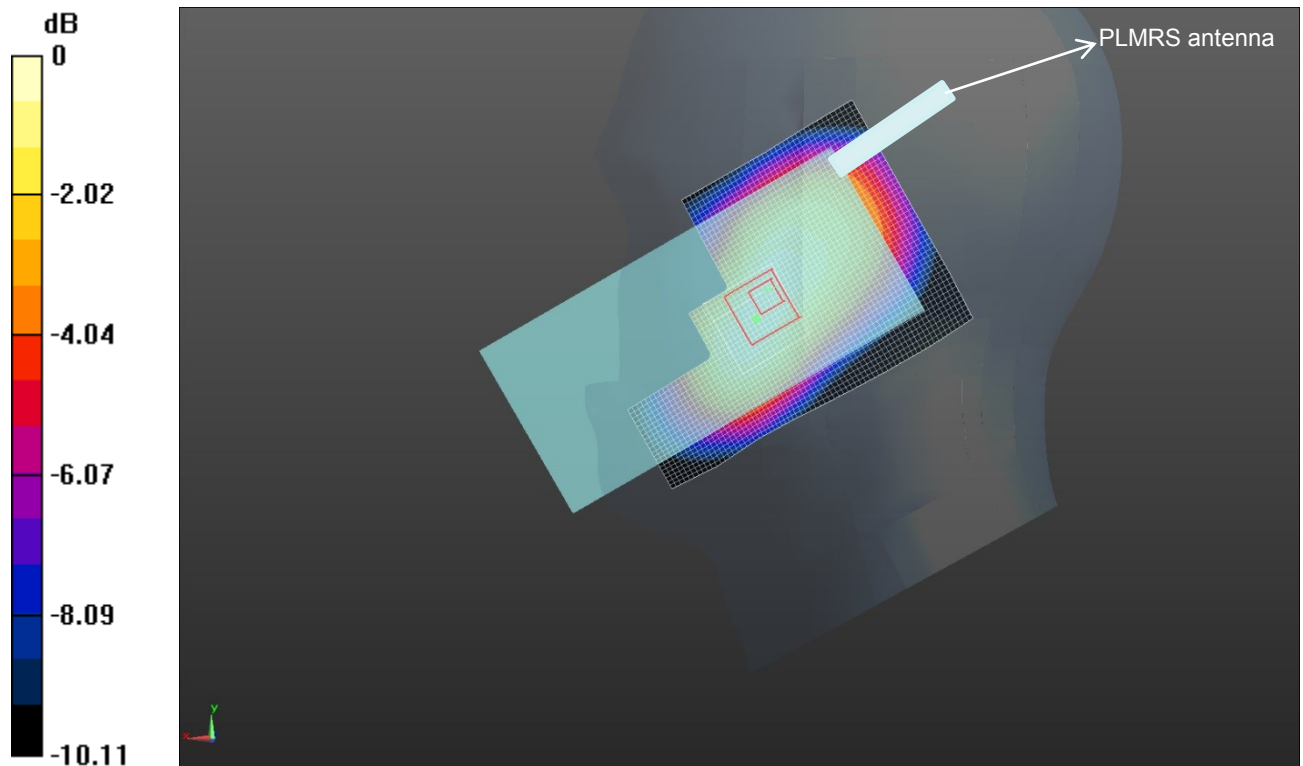

Left Head Cheek (GSM850 GPRS 4TS Middle Channel)

Test mode: PCS1900 GPRS 4TS Test Position: Left Head Cheek Test Plot: H2

Date: 2017-06-03

Communication System: Customer System; Frequency: 1880.0 MHz; Duty Cycle: 1:2

Medium parameters used (interpolated):  $f = 1880.0$  MHz;  $\sigma = 1.42$  s/m;  $\epsilon = 40.05$ ;  $\rho = 1000$  kg/m<sup>3</sup>

Phantom section: Left Section

DASY5 Configuration:

•Probe: ES3DV3 - SN3292; ConvF(5.26,5.26,5.26); Calibrated: 02/09/2016;

•Sensor-Surface: 4mm (Mechanical Surface Detection)

•Electronics: DAE4 Sn1315; Calibrated: 2016/7/26

•Phantom: SAM 1; Type: SAM;

•Measurement SW: DASY52, Version 52.8 (2); SEMCAD X Version 14.6.6 (6824)

**Area Scan (71x121x1):** Interpolated grid:  $dx = 1.500$  mm,  $dy = 1.500$  mm

Maximum value of SAR (interpolated) = 0.307 W/kg

**Zoom Scan (7x7x7)/Cube 0:** Measurement grid:  $dx = 5$  mm,  $dy = 5$  mm,  $dz = 5$  mm

Reference Value = 3.151 V/m; Power Drift = 0.18 dB

Peak SAR (extrapolated) = 0.424 mW/g

**SAR(1 g) = 0.284 mW/g; SAR(10 g) = 0.180 mW/g**

Maximum value of SAR (measured) = 0.297 W/kg

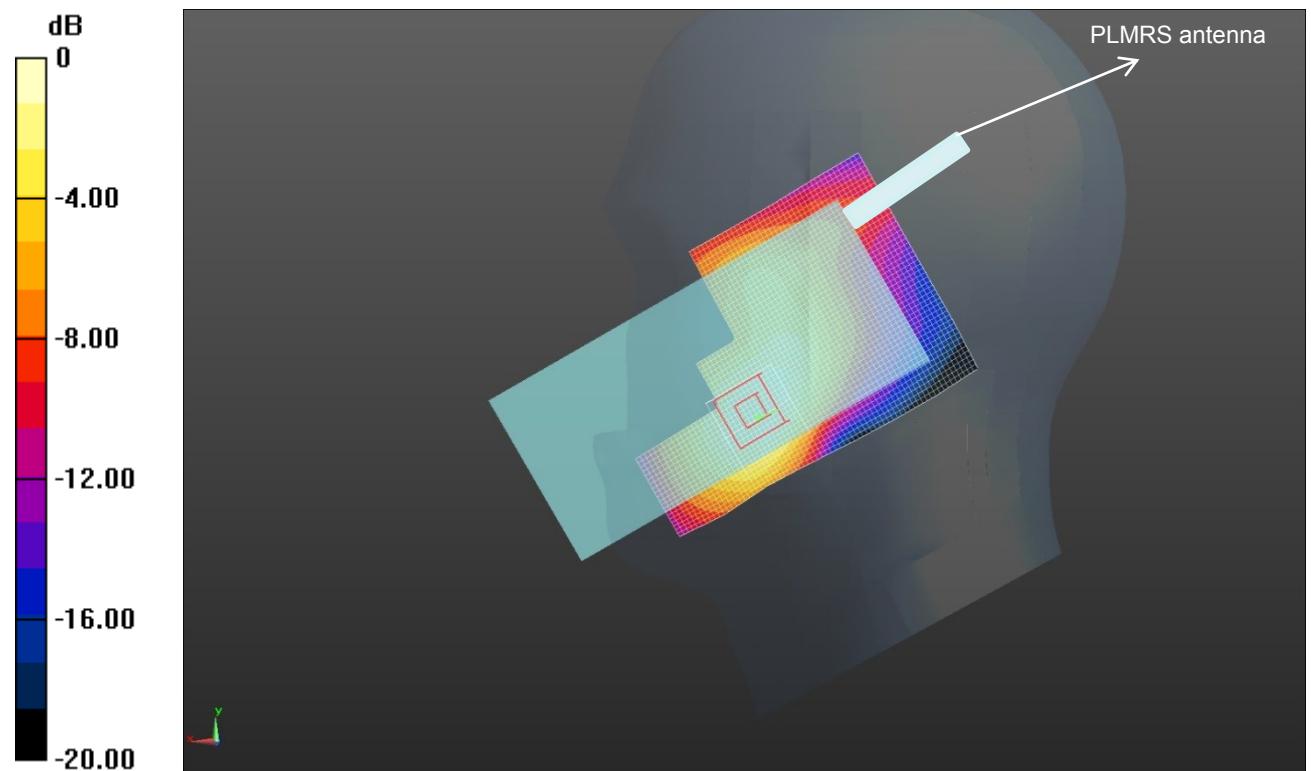

Left Head (PCS1900 Middle Channel)

Test mode: LTE Band 2

Test Position: Left Head Cheek

Test Plot: H3

Date: 2017-06-05

Communication System: Customer System; Frequency: 1880.0 MHz; Duty Cycle:1:1

Medium parameters used (interpolated):  $f=1880.0$  MHz;  $\sigma=1.42$ s/m;  $\epsilon=40.05$ ;  $\rho=1000$  kg/m<sup>3</sup>

Phantom section: Left Head Section:

**DASY5 Configuration:**

- Probe: ES3DV3 - SN3292; ConvF(5.26,5.26,5.26); Calibrated: 02/09/2016;
- Sensor-Surface: 4mm (Mechanical Surface Detection)
- Electronics: DAE4 Sn1315; Calibrated: 26/07/2016
- Phantom: SAM 1; Type: SAM;
- Measurement SW: DASY52, Version 52.8 (2); SEMCAD X Version 14.6.6 (6824)

**Area Scan (71x121x1):** Interpolated grid: dx=1.500 mm, dy=1.500 mm

Maximum value of SAR (interpolated) = 0.217 W/kg

**Zoom Scan (6x6x7)/Cube 0:** Measurement grid: dx=8mm, dy=8mm, dz=5mm

Reference Value = 3.369 V/m; Power Drift = -0.04 dB

Peak SAR (extrapolated) = 0.304 mW/g

**SAR(1 g) = 0.197 mW/g; SAR(10 g) = 0.123 mW/g**

Maximum value of SAR (measured) = 0.214 W/kg

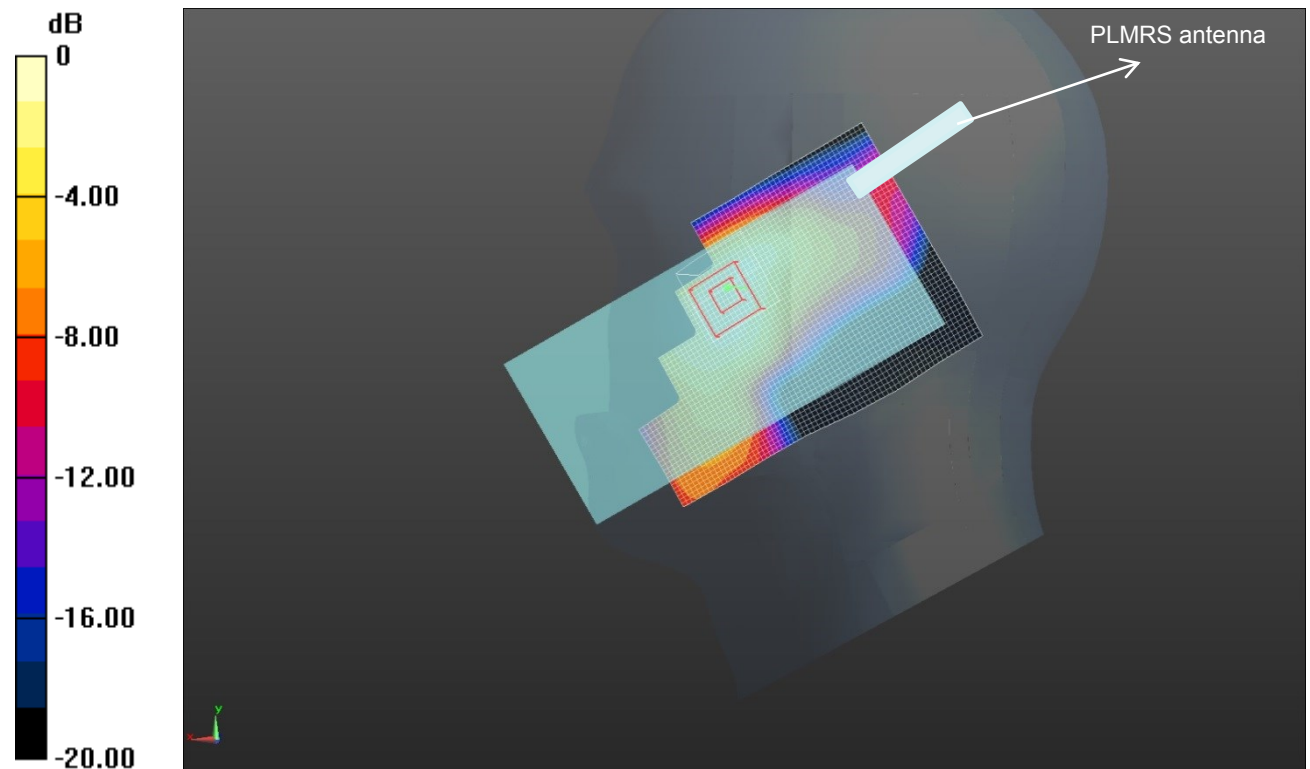

Left Head Cheek (LTE Band 2 Middle Channel)

Test mode: LTE Band 4      Test Position: Left Head Cheek      Test Plot: H4

Date: 2017-05-26

Communication System: Generic LTE; Frequency: 1732.5 MHz; Duty Cycle: 1:1

Medium parameters used (interpolated):  $f = 1732.5$  MHz;  $\sigma = 1.41$ s/m;  $\epsilon_r = 40.73$ ;  $\rho = 1000$  kg/m<sup>3</sup>

Phantom section: Left Head Section:

**DASY5 Configuration:**

Probe: ES3DV3 - SN3292; ConvF(5.54,5.54,5.54); Calibrated: 02/09/2016;

•Sensor-Surface: 4mm (Mechanical Surface Detection)

•Electronics: DAE4 Sn1315; Calibrated: 26/07/2016

•Phantom: SAM 1; Type: SAM;

•Measurement SW: DASY52, Version 52.8 (2); SEMCAD X Version 14.6.6 (6824)

**Area Scan (71x121x1):** Interpolated grid: dx=1.500 mm, dy=1.500 mm

Maximum value of SAR (interpolated) =0.256 W/kg

**Zoom Scan (7x7x7)/Cube 0:** Measurement grid: dx=5mm, dy=5mm, dz=5mm

Reference Value = 7.178 V/m; Power Drift = 0.10 dB

Peak SAR (extrapolated) = 0.330 mW/g

**SAR(1 g) = 0.221 mW/g; SAR(10 g) = 0.145 mW/g**

Maximum value of SAR (measured) = 0.243 W/kg

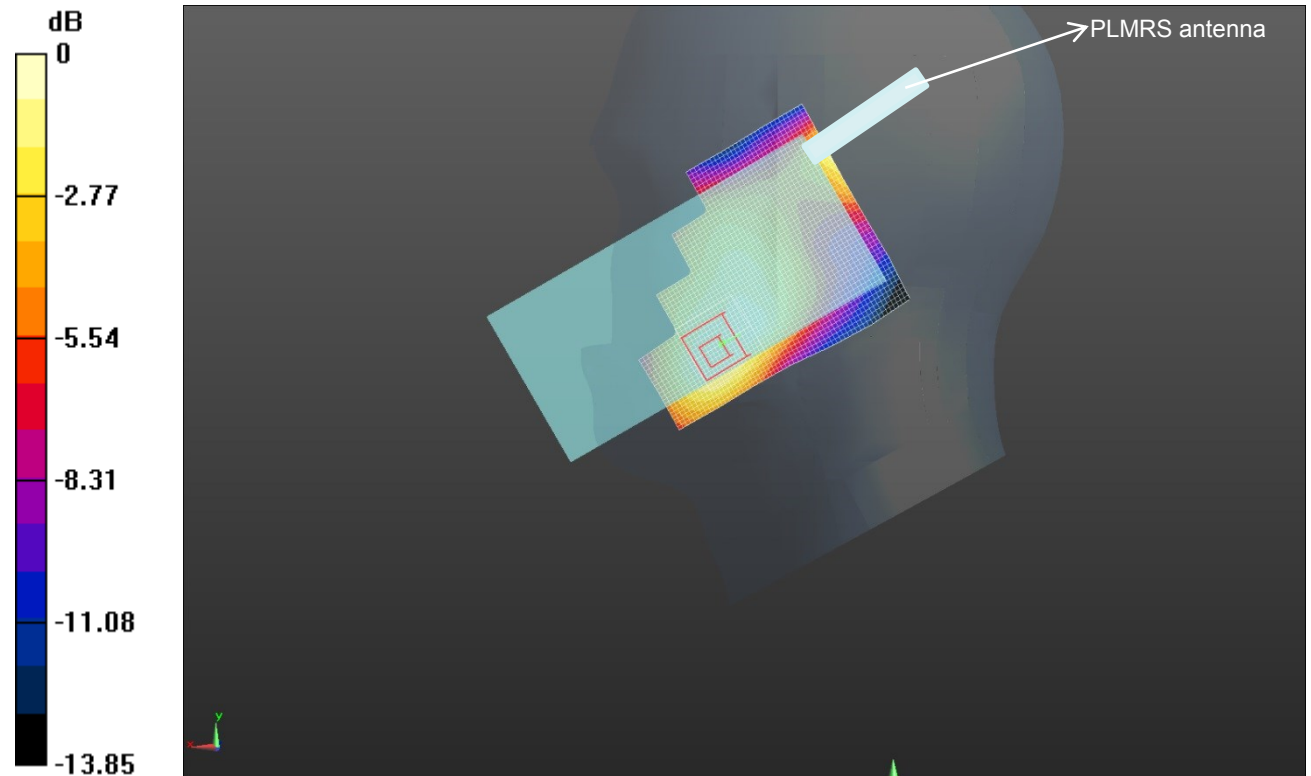

Left Head Cheek (LTE Band 4 Middle Channel)

Test mode: LTE Band 5      Test Position: Left Head Cheek      Test Plot: H5

Date: 2017-05-22

Communication System: Customer System; Frequency: 836.5 MHz; Duty Cycle:1:1

Medium parameters used (interpolated):  $f = 836.5$  MHz;  $\sigma = 0.92$ s/m;  $\epsilon_r = 41.62$ ;  $\rho = 1000$  kg/m<sup>3</sup>

Phantom section: Left Head Section:

**DASY5 Configuration:**

- Probe: ES3DV3 - SN3292; ConvF(6.53, 6.53, 6.53); Calibrated: 02/09/2016;
- Sensor-Surface: 4mm (Mechanical Surface Detection)
- Electronics: DAE4 Sn1315; Calibrated: 26/07/2016
- Phantom: SAM 1; Type: SAM;
- Measurement SW: DASY52, Version 52.8 (2); SEMCAD X Version 14.6.6 (6824)

**Area Scan (71x121x1):** Interpolated grid: dx=1.500 mm, dy=1.500 mm

Maximum value of SAR (interpolated) = 0.258W/kg

**Zoom Scan (7x7x7)/Cube 0:** Measurement grid: dx=5mm, dy=5mm, dz=5mm

Reference Value = 5.349 V/m; Power Drift = -0.11 dB

Peak SAR (extrapolated) = 0.290 mW/g

**SAR(1 g) = 0.246 mW/g; SAR(10 g) = 0.191 mW/g**

Maximum value of SAR (measured) = 0.256 W/kg

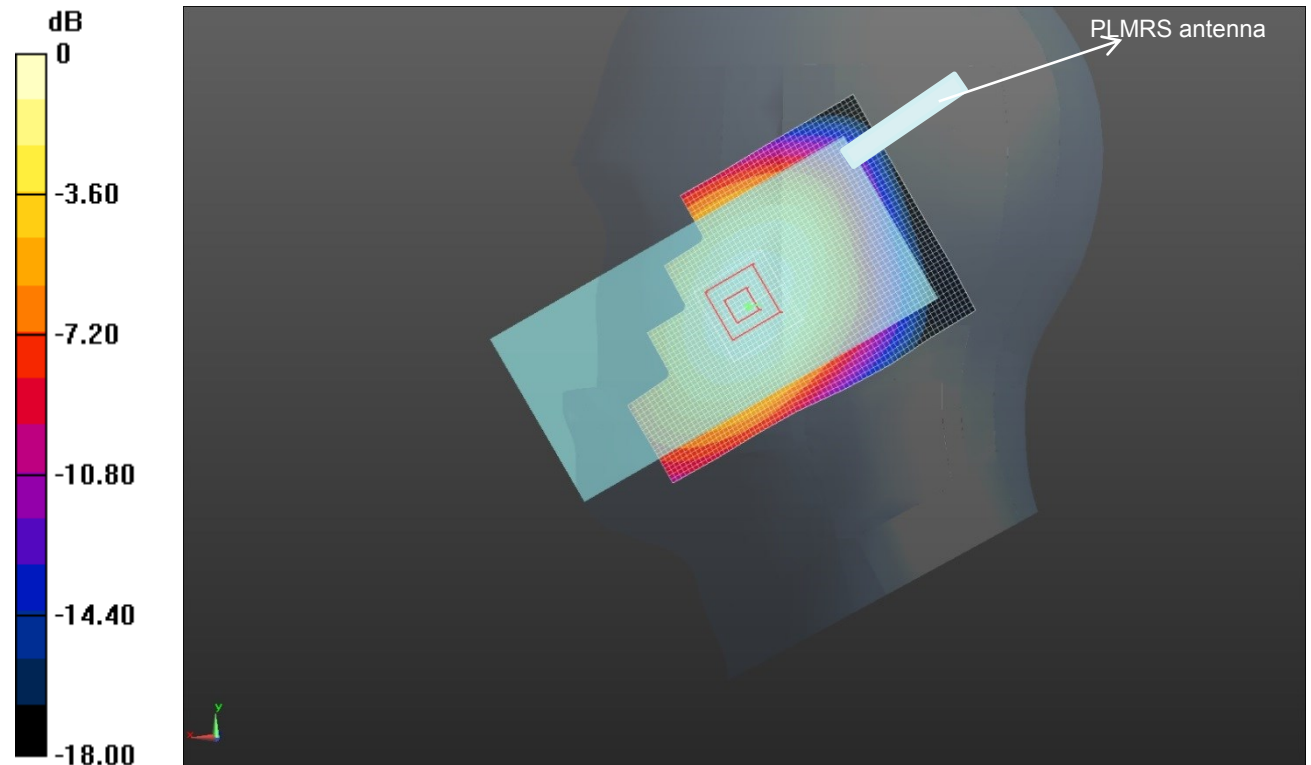

Left Head Cheek (LTE Band 5 Middle Channel)

Test mode: LTE Band 7

Test Position: Left Head Cheek

Test Plot: H6

Date: 2017-06-12

Communication System: Customer System; Frequency: 2535.0 MHz; Duty Cycle:1:1

Medium parameters used (interpolated):  $f = 2535.0$  MHz;  $\sigma = 1.93$ s/m;  $\epsilon = 38.83$ ;  $\rho = 1000$  kg/m<sup>3</sup>

Phantom section: Left Head Section:

**DASY5 Configuration:**

- Probe: ES3DV3 - SN3292; ConvF(4.77, 4.77, 4.77); Calibrated: 02/09/2016;
- Sensor-Surface: 4mm (Mechanical Surface Detection)
- Electronics: DAE4 Sn1315; Calibrated: 26/07/2016
- Phantom: SAM 1; Type: SAM;
- Measurement SW: DASY52, Version 52.8 (2); SEMCAD X Version 14.6.6 (6824)

**Area Scan (71x121x1):** Interpolated grid: dx=1.500 mm, dy=1.500 mm

Maximum value of SAR (interpolated) = 0.182 W/kg

**Zoom Scan (7x7x7)/Cube 0:** Measurement grid: dx=5mm, dy=5mm, dz=5mm

Reference Value = 1.380 V/m; Power Drift = 0.12 dB

Peak SAR (extrapolated) = 0.301 mW/g

**SAR(1 g) = 0.168 mW/g; SAR(10 g) = 0.095 mW/g**

Maximum value of SAR (measured) = 0.181 W/kg

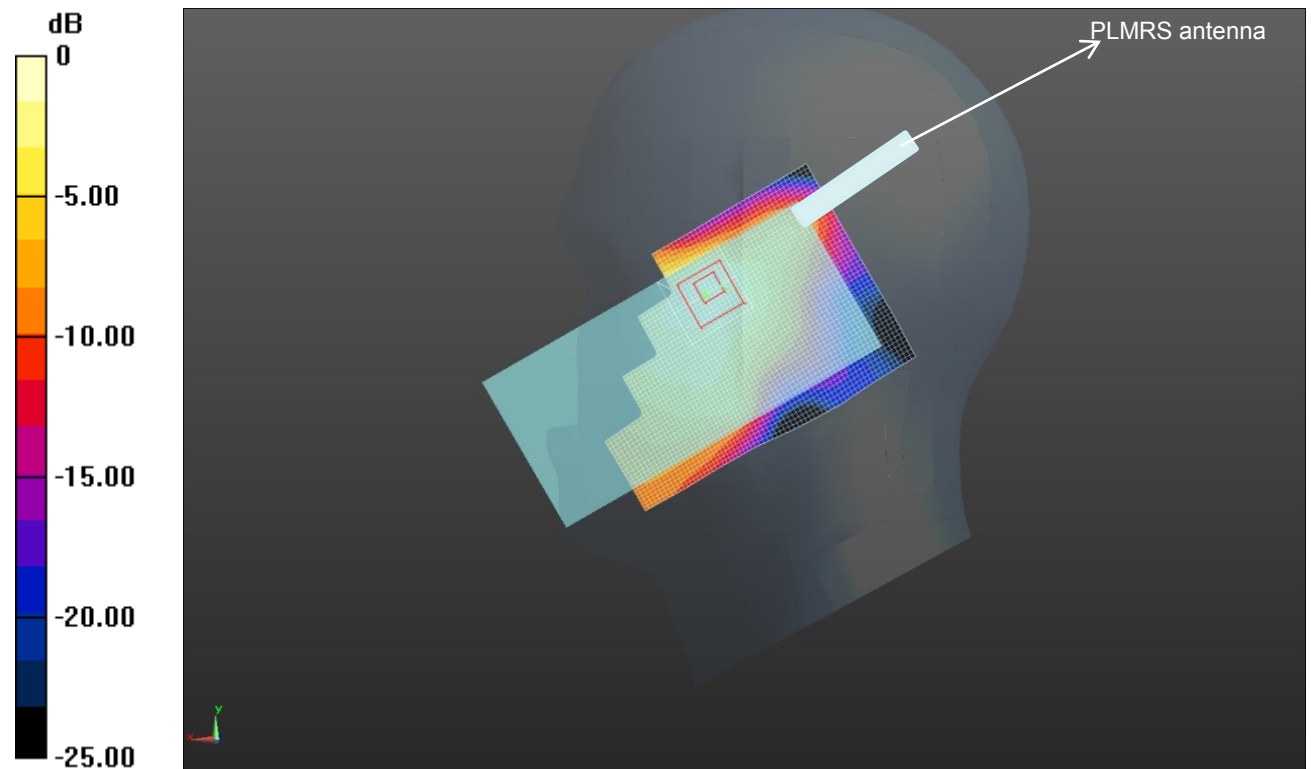

Left Head Cheek (LTE Band 7 Middle Channel)



Test mode: LTE Band 26      Test Position: Left Head Cheek      Test Plot: H7

Date: 2017-05-23

Communication System: Customer System; Frequency: 831.5 MHz; Duty Cycle:1:1

Medium parameters used (interpolated):  $f=831.5$  MHz;  $\sigma=0.92$ S/m;  $\epsilon_r=41.62$ ;  $\rho=1000$  kg/m<sup>3</sup>

Phantom section: Left Head Section:

**DASY5 Configuration:**

- Probe: ES3DV3 - SN3292; ConvF(6.53, 6.53, 6.53); Calibrated: 02/09/2016;
- Sensor-Surface: 4mm (Mechanical Surface Detection)
- Electronics: DAE4 Sn1315; Calibrated: 26/07/2016
- Phantom: SAM 1; Type: SAM;
- Measurement SW: DASY52, Version 52.8 (2); SEMCAD X Version 14.6.6 (6824)

**Area Scan (71x121x1):** Interpolated grid:  $dx=1.500$  mm,  $dy=1.500$  mm  
 Maximum value of SAR (interpolated) = 0.288 W/kg

**Zoom Scan (7x7x7)/Cube 0:** Measurement grid:  $dx=5$ mm,  $dy=5$ mm,  $dz=5$ mm  
 Reference Value = 6.437 V/m; Power Drift = 0.16 dB  
 Peak SAR (extrapolated) = 0.309 mW/g  
**SAR(1 g) = 0.264 mW/g; SAR(10 g) = 0.205 mW/g**  
 Maximum value of SAR (measured) = 0.273 W/kg

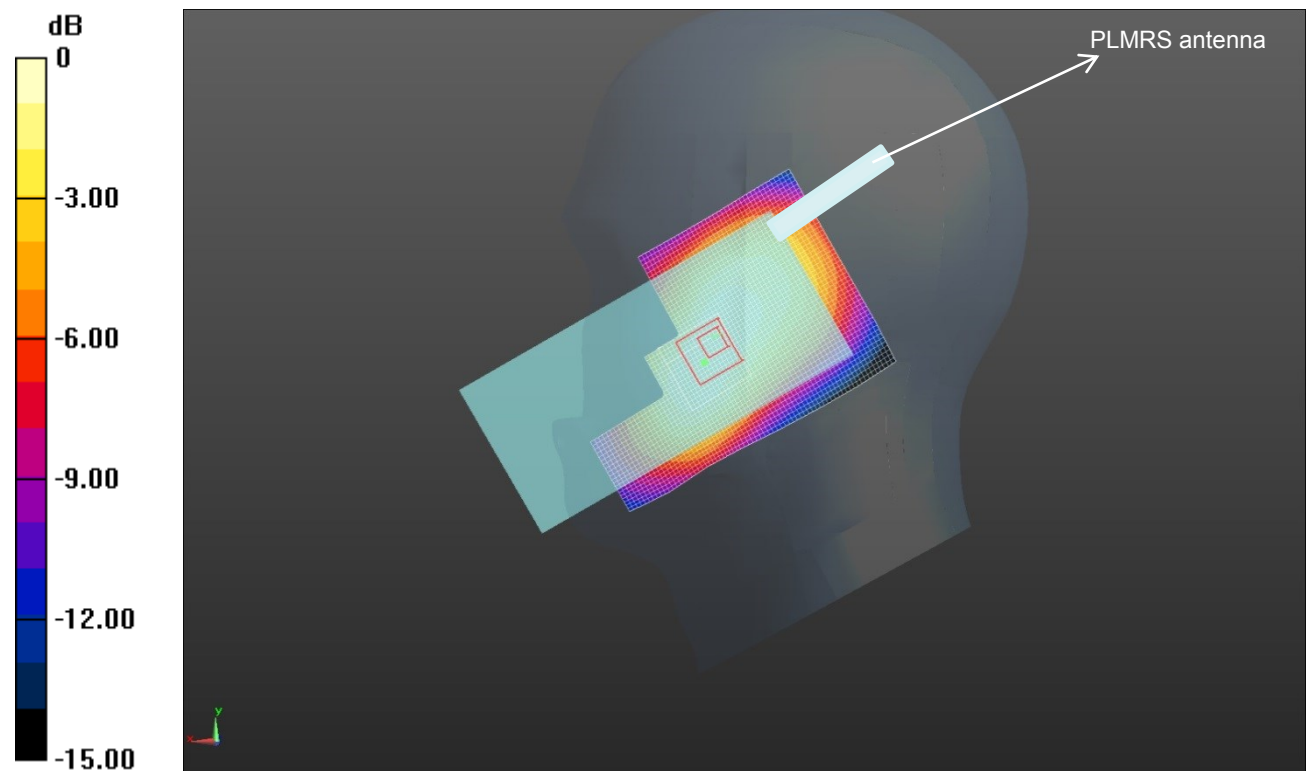

Left Head Cheek (LTE Band 26 Middle Channel)



Test mode: LTE Band 41

Test Position: Left Head Cheek

Test Plot: H8

Date: 2017-06-13

Communication System: Customer System; Frequency: 2593.0 MHz; Duty Cycle:1:1

Medium parameters used (interpolated):  $f = 2593.0$  MHz;  $\sigma = 1.93$ s/m;  $\epsilon = 38.83$ ;  $\rho = 1000$  kg/m<sup>3</sup>

Phantom section: Left Head Section:

**DASY5 Configuration:**

- Probe: ES3DV3 - SN3292; ConvF(4.77, 4.77, 4.77); Calibrated: 02/09/2016;
- Sensor-Surface: 4mm (Mechanical Surface Detection)
- Electronics: DAE4 Sn1315; Calibrated: 26/07/2016
- Phantom: SAM 1; Type: SAM;
- Measurement SW: DASY52, Version 52.8 (2); SEMCAD X Version 14.6.6 (6824)

**Area Scan (71x121x1):** Interpolated grid: dx=1.500 mm, dy=1.500 mm

Maximum value of SAR (interpolated) =0.097 W/kg

**Zoom Scan (7x7x7)/Cube 0:** Measurement grid: dx=5mm, dy=5mm, dz=5mm

Reference Value = 1.861 V/m; Power Drift = -0.10 dB

Peak SAR (extrapolated) = 0.139 mW/g

**SAR(1 g) = 0.084 mW/g; SAR(10 g) = 0.050 mW/g**

Maximum value of SAR (measured) = 0.089 W/kg

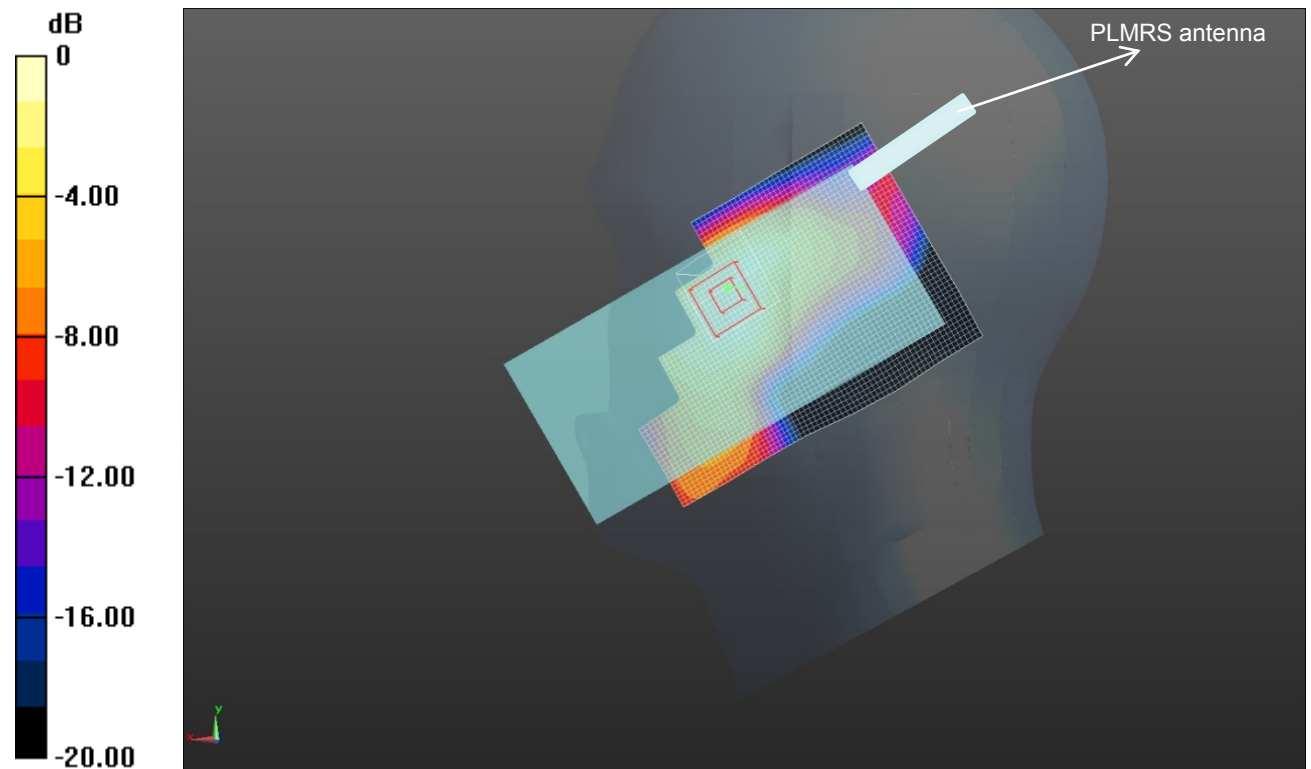

Left Head Cheek (LTE Band 41 Middle Channel)

Test mode: WLAN 802.11b      Test Position: Left Head Cheek      Test Plot: H9

Date: 2017-06-09

Communication System: Customer System; Frequency: 2437.0 MHz; Duty Cycle:1:1

Medium parameters used (interpolated):  $f=2437.0$  MHz;  $\sigma=1.79$ S/m;  $\epsilon_r=39.11$ ,  $\rho=1000$  kg/m<sup>3</sup>

Phantom section: Left Head Section:

**DASY5 Configuration:**

- Probe: ES3DV3 - SN3292; ConvF(4.97,4.97,4.97); Calibrated: 02/09/2016;
- Sensor-Surface: 4mm (Mechanical Surface Detection)
- Electronics: DAE4 Sn1315; Calibrated: 26/07/2016
- Phantom: SAM 1; Type: SAM;
- Measurement SW: DASY52, Version 52.8 (2); SEMCAD X Version 14.6.6 (6824)

**Area Scan (71x121x1):** Interpolated grid:  $dx=1.500$  mm,  $dy=1.500$  mm  
 Maximum value of SAR (interpolated) = 0.278 W/kg

**Zoom Scan (7x7x7)/Cube 0:** Measurement grid:  $dx=5$ mm,  $dy=5$ mm,  $dz=5$ mm  
 Reference Value = 11.889 V/m; Power Drift = -0.10 dB  
 Peak SAR (extrapolated) = 0.508 mW/g  
**SAR(1 g) = 0.270 mW/g; SAR(10 g) = 0.137 mW/g**

Maximum value of SAR (measured) = 0.297 W/kg

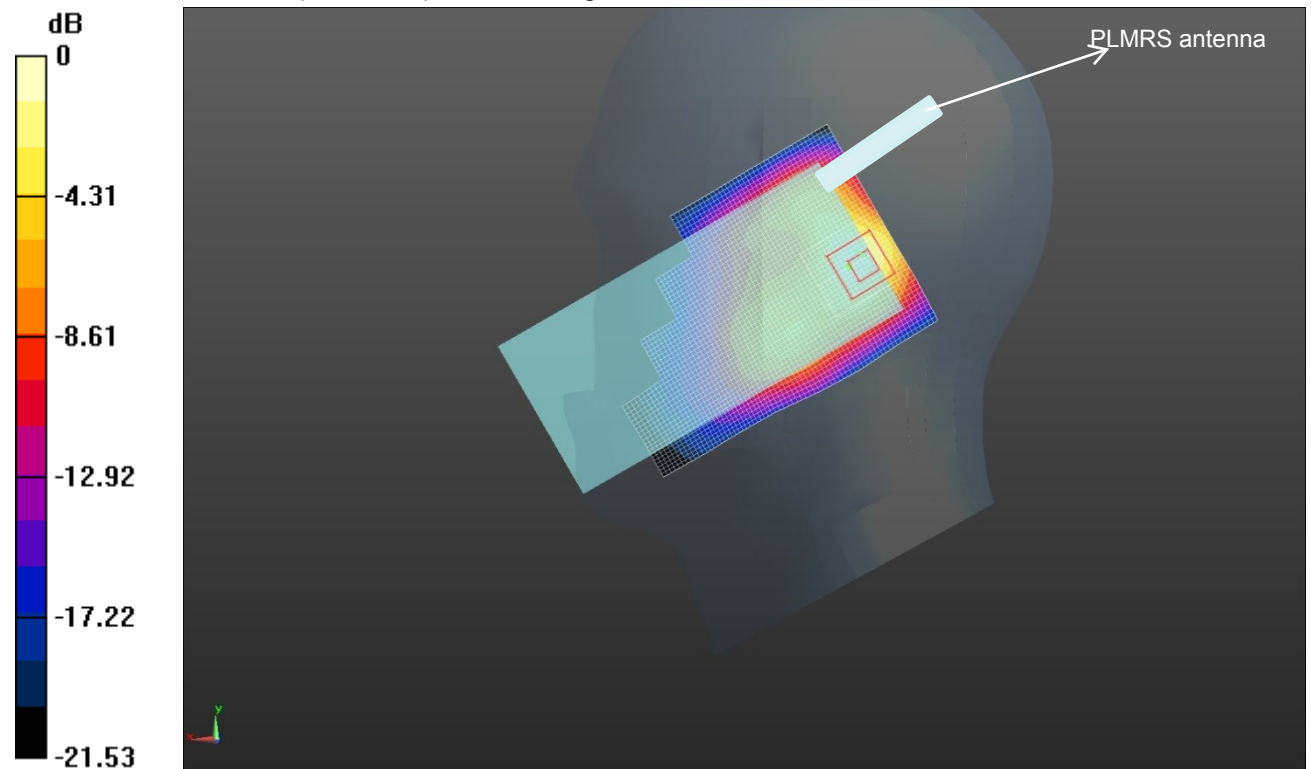

Left Head Cheek (WLAN middle Channel)

Test mode: GSM850 GPRS 4TS Test Position: Body- worn Rear Side Test Plot: B1

Date: 2017-05-24

Communication System: Customer System; Frequency:836.6 MHz; Duty Cycle:1:2

Medium parameters used (interpolated):  $f=836.6$  MHz;  $\sigma=0.96$ s/m;  $\epsilon=55.15$ ;  $\rho=1000$  kg/m<sup>3</sup>

Phantom section: Flat Section:

**DASY 5 Configuration:**

- Probe: ES3DV3 - SN3292; ConvF(6.27, 6.27, 6.27); Calibrated: 02/09/2016;
- Sensor-Surface: 4mm (Mechanical Surface Detection)
- Electronics: DAE4 Sn1315; Calibrated: 26/07/2016
- Phantom: SAM 1; Type: SAM;
- Measurement SW: DASY52, Version 52.8 (2); SEMCAD X Version 14.6.6 (6824)

**Area Scan (71x121x1):** Interpolated grid: dx=1.500 mm, dy=1.500 mm

Maximum value of SAR (interpolated) =0.189 W/kg

**Zoom Scan (7x7x7)/Cube 0:** Measurement grid: dx=5mm, dy=5mm, dz=5mm

Reference Value = 13.430 V/m; Power Drift = 0.05 dB

Peak SAR (extrapolated) = 0.222 mW/g

**SAR(1 g) = 0.180 mW/g; SAR(10 g) = 0.136 mW/g**

Maximum value of SAR (measured) = 0.190 W/kg

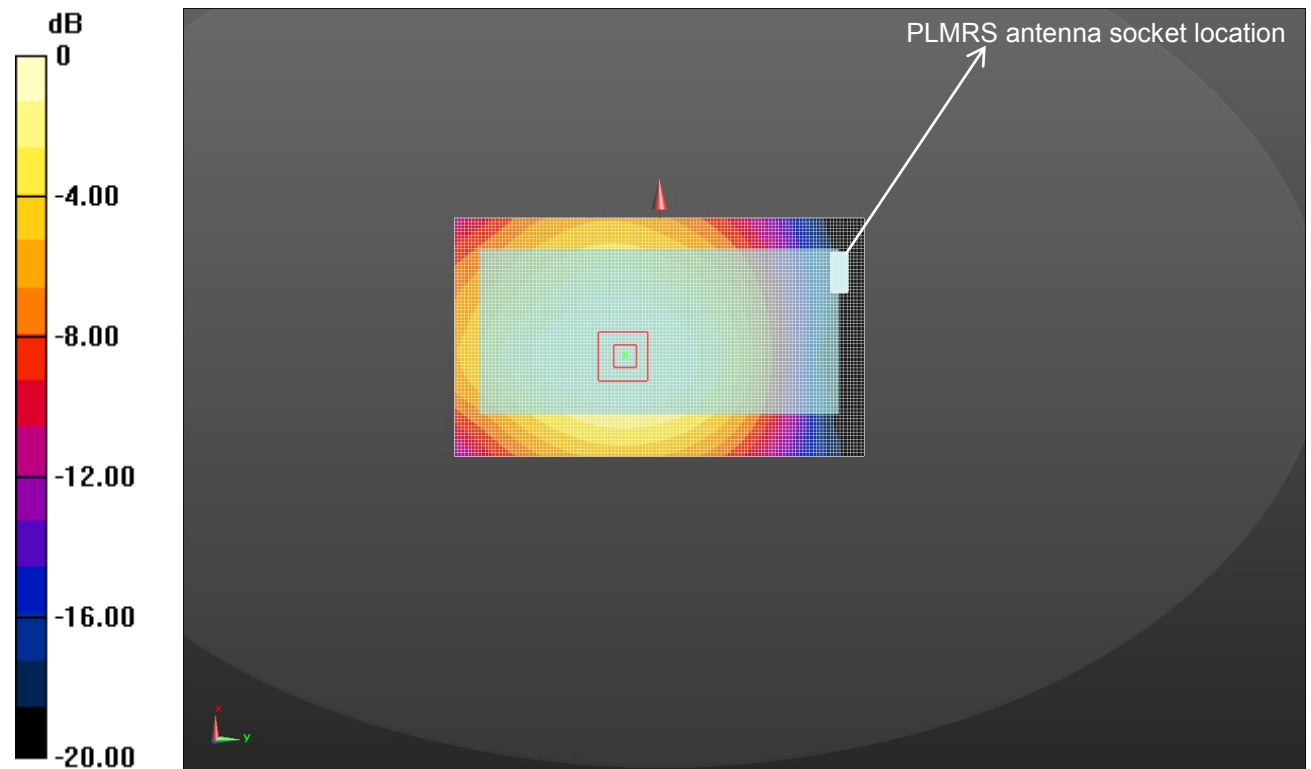

Body- worn Rear Side (GSM850 GPRS 4TS Middle Channel)

Test mode: PCS1900 GPRS 4TS Test Position: Body- worn Rear Side Test Plot: B2

Date: 2017-06-06

Communication System: Customer System; Frequency: 1880.0 MHz; Duty Cycle: 1:2

Medium parameters used (interpolated):  $f = 1880.0$  MHz;  $\sigma = 1.53$ s/m;  $\epsilon = 53.12$ ;  $\rho = 1000$  kg/m<sup>3</sup>

Phantom section: Flat Section

**DASY5 Configuration:**

- Probe: ES3DV3 - SN3292; ConvF(5.05,5.05,5.05); Calibrated: 02/09/2016;
- Sensor-Surface: 4mm (Mechanical Surface Detection)
- Electronics: DAE4 Sn1315; Calibrated: 26/07/2016
- Phantom: SAM 1; Type: SAM;
- Measurement SW: DASY52, Version 52.8 (2); SEMCAD X Version 14.6.6 (6824)

**Area Scan (71x121x1):** Interpolated grid: dx=1.500 mm, dy=1.500 mm

Maximum value of SAR (interpolated) =0.110 W/kg

**Zoom Scan (7x7x7)/Cube 0:** Measurement grid: dx=5mm, dy=5mm, dz=5mm

Reference Value = 6.346 V/m; Power Drift = -0.10 dB

Peak SAR (extrapolated) = 0.153 mW/g

**SAR(1 g) = 0.101 mW/g; SAR(10 g) = 0.065 mW/g**

Maximum value of SAR (measured) = 0.110 W/kg

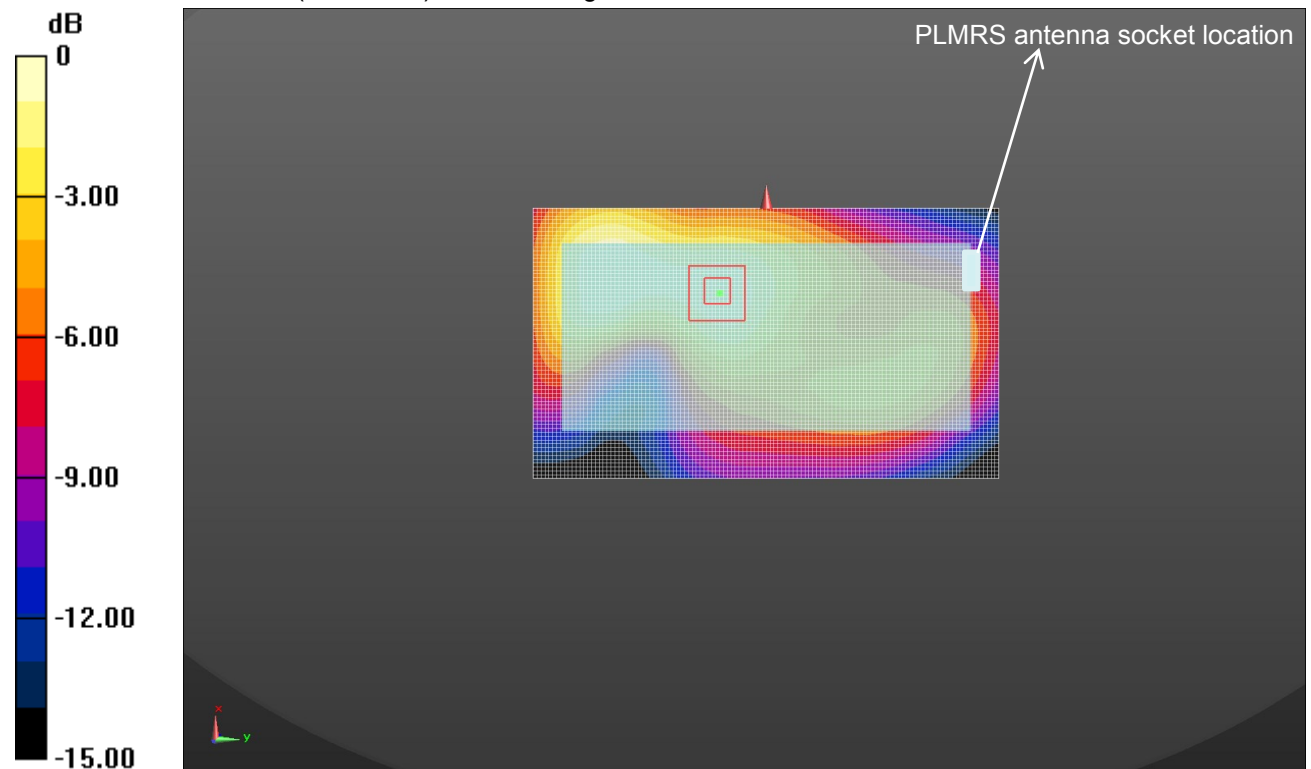

Body- worn Rear Side (PCS1900 GPRS 4TS Middle Channel)

Test mode: LTE Band 2

Test Position: Body- worn Rear Side

Test Plot: B3

Date: 2017-06-06

Communication System: Customer System; Frequency: 1880.0 MHz; Duty Cycle:1:1

Medium parameters used (interpolated):  $f=1880.0$  MHz;  $\sigma=1.53$ s/m;  $\epsilon=53.12$ ;  $\rho=1000$  kg/m<sup>3</sup>

Phantom section: Flat Section

**DASY5 Configuration:**

- Probe: ES3DV3 - SN3292; ConvF(5.05,5.05,5.05); Calibrated: 02/09/2016;
- Sensor-Surface: 4mm (Mechanical Surface Detection)
- Electronics: DAE4 Sn1315; Calibrated: 26/07/2016
- Phantom: SAM 1; Type: SAM;
- Measurement SW: DASY52, Version 52.8 (2); SEMCAD X Version 14.6.6 (6824)

**Area Scan (71x121x1):** Interpolated grid: dx=1.500 mm, dy=1.500 mm

Maximum value of SAR (interpolated) = 0.184 W/kg

**Zoom Scan (7x7x7)/Cube 0:** Measurement grid: dx=5mm, dy=5mm, dz=5mm

Reference Value = 8.313 V/m; Power Drift = 0.11 dB

Peak SAR (extrapolated) = 0.261 mW/g

**SAR(1 g) = 0.172 mW/g; SAR(10 g) = 0.109 mW/g**

Maximum value of SAR (measured) = 0.185 W/kg

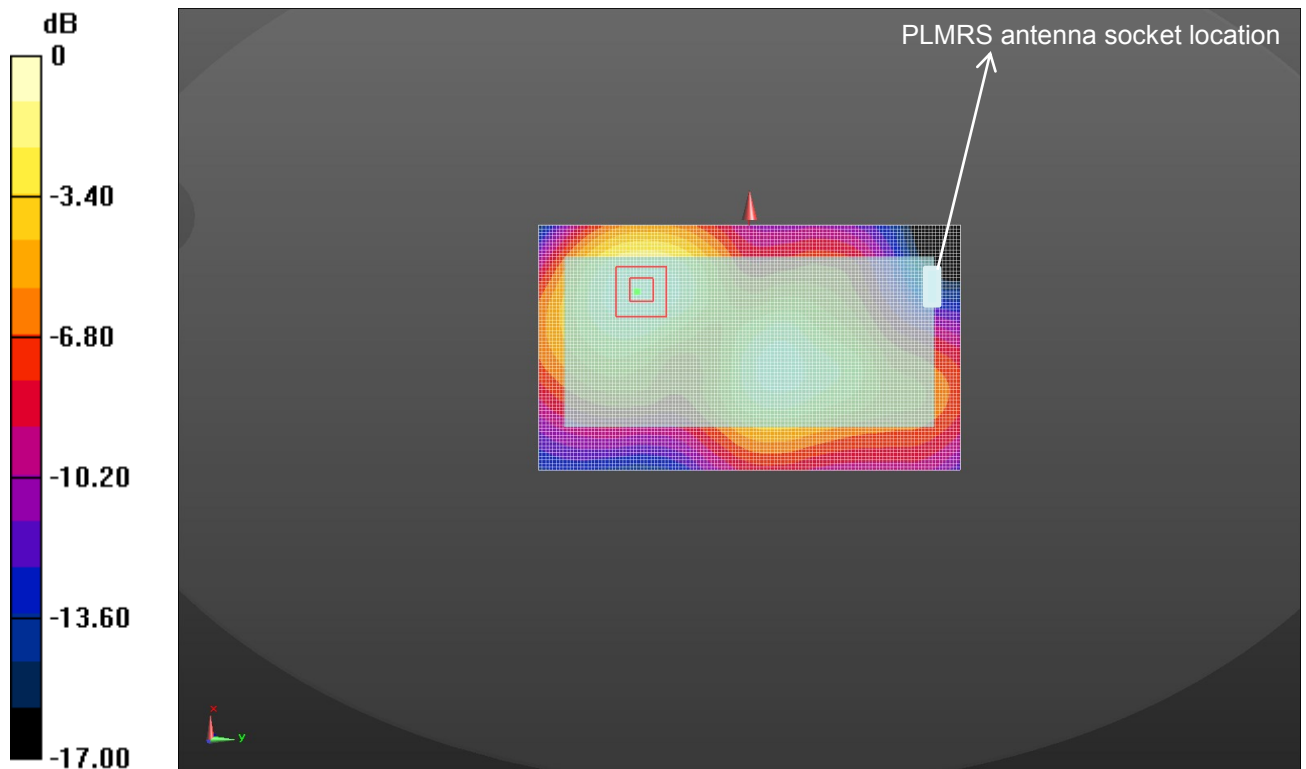

Body- worn Rear Side (LTE Band 2 Middle Channel)

Test mode: LTE Band 4      Test Position: Body- worn Rear Side      Test Plot: B4

Date: 2017-06-01

Communication System: Generic LTE; Frequency: 1732.5 MHz; Duty Cycle: 1:1

Medium parameters used (interpolated):  $f = 1732.5$  MHz;  $\sigma = 1.44$  s/m;  $\epsilon = 53.52$ ;  $\rho = 1000$  kg/m<sup>3</sup>

Phantom section: Flat Section

**DASY5 Configuration:**

- Probe: ES3DV3 - SN3292; ConvF(5.28,5.28,5.28); Calibrated: 02/09/2016;
- Sensor-Surface: 4mm (Mechanical Surface Detection)
- Electronics: DAE4 Sn1315; Calibrated: 26/07/2016
- Phantom: SAM 1; Type: SAM;
- Measurement SW: DASY52, Version 52.8 (2); SEMCAD X Version 14.6.6 (6824)

**Area Scan (71x121x1):** Interpolated grid: dx=1.500 mm, dy=1.500 mm

Maximum value of SAR (interpolated) = 0.287 W/kg

**Zoom Scan (7x7x7)/Cube 0:** Measurement grid: dx=5mm, dy=5mm, dz=5mm

Reference Value = 13.015 V/m; Power Drift = 0.17 dB

Peak SAR (extrapolated) = 0.386 mW/g

**SAR(1 g) = 0.269 mW/g; SAR(10 g) = 0.184 mW/g**

Maximum value of SAR (measured) = 0.285 W/kg

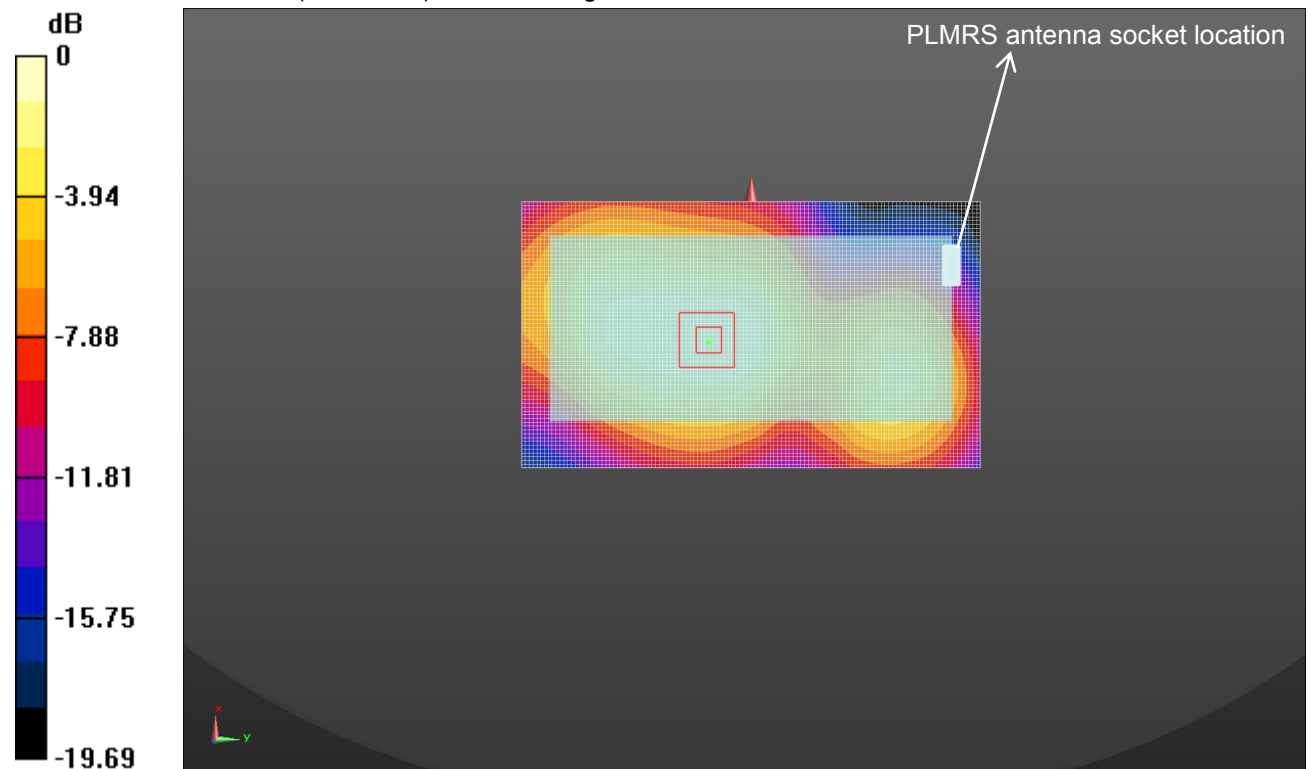

Body- worn Rear Side (LTE Band 4 Middle Channel)

Test mode: LTE Band 5      Test Position: Body- worn Rear Side      Test Plot: B5

Date: 2017-05-24

Communication System: Customer System; Frequency: 836.6 MHz; Duty Cycle:1:1  
 Medium parameters used (interpolated): f=836.6 MHz;  $\sigma=0.96\text{s/m}$ ;  $\epsilon=55.15$ ;  $\rho=1000\text{ kg/m}^3$   
 Phantom section: Flat Section

**DASY5 Configuration:**

- Probe: ES3DV3 - SN3292; ConvF(6.27, 6.27, 6.27); Calibrated: 02/09/2016;
- Sensor-Surface: 4mm (Mechanical Surface Detection)
- Electronics: DAE4 Sn1315; Calibrated: 26/07/2016
- Phantom: SAM 1; Type: SAM;
- Measurement SW: DASY52, Version 52.8 (2); SEMCAD X Version 14.6.6 (6824)

**Area Scan (71x121x1):** Interpolated grid: dx=1.500 mm, dy=1.500 mm  
 Maximum value of SAR (interpolated) = 0.192 mW/g

**Zoom Scan (7x7x7)/Cube 0:** Measurement grid: dx=5mm, dy=5mm, dz=5mm  
 Reference Value = 10.106 V/m; Power Drift = -0.10 dB  
 Peak SAR (extrapolated) = 0.307 mW/g  
**SAR(1 g) = 0.186 mW/g; SAR(10 g) = 0.164 mW/g**

Maximum value of SAR (measured) = 0.190 W/kg

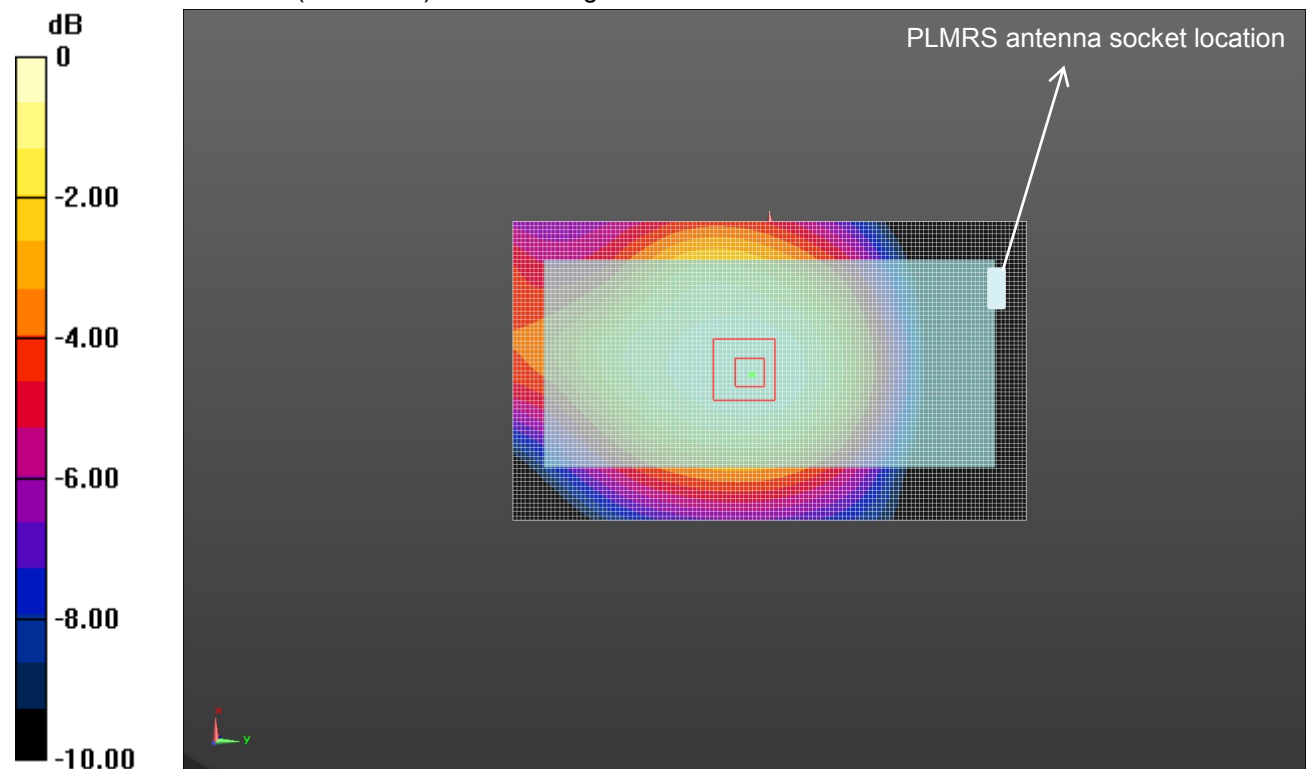

Body- worn Rear Side (LTE Band 5 Middle Channel)



Test mode: LTE Band 7      Test Position: Body- worn Rear Side      Test Plot: B6

Date: 2017-06-14

Communication System: Generic LTE; Frequency: 2535 MHz; Duty Cycle: 1:1  
 Medium parameters used:  $f = 2535$  MHz;  $\sigma = 2.14$  s/m;  $\epsilon = 51.12$ ;  $\rho = 1000$  kg/m<sup>3</sup>  
 Phantom section: Flat Section

**DASY5 Configuration:**

- Probe: ES3DV3 - SN3292; ConvF(4.52,4.52,4.52); Calibrated: 02/09/2016;
- Sensor-Surface: 4mm (Mechanical Surface Detection)
- Electronics: DAE4 Sn1315; Calibrated: 26/07/2016
- Phantom: SAM 1; Type: SAM;
- Measurement SW: DASY52, Version 52.8 (2); SEMCAD X Version 14.6.6 (6824)

**Area Scan (71x121x1):** Interpolated grid: dx=1.500 mm, dy=1.500 mm  
 Maximum value of SAR (interpolated) = 0.284 W/kg

**Zoom Scan (7x7x7)/Cube 0:** Measurement grid: dx=5mm, dy=5mm, dz=5mm  
 Reference Value = 6.042 V/m; Power Drift = -0.12 dB  
 Peak SAR (extrapolated) = 0.491 mW/g  
**SAR(1 g) = 0.253 mW/g; SAR(10 g) = 0.128 mW/g**  
 Maximum value of SAR (measured) = 0.288 W/kg

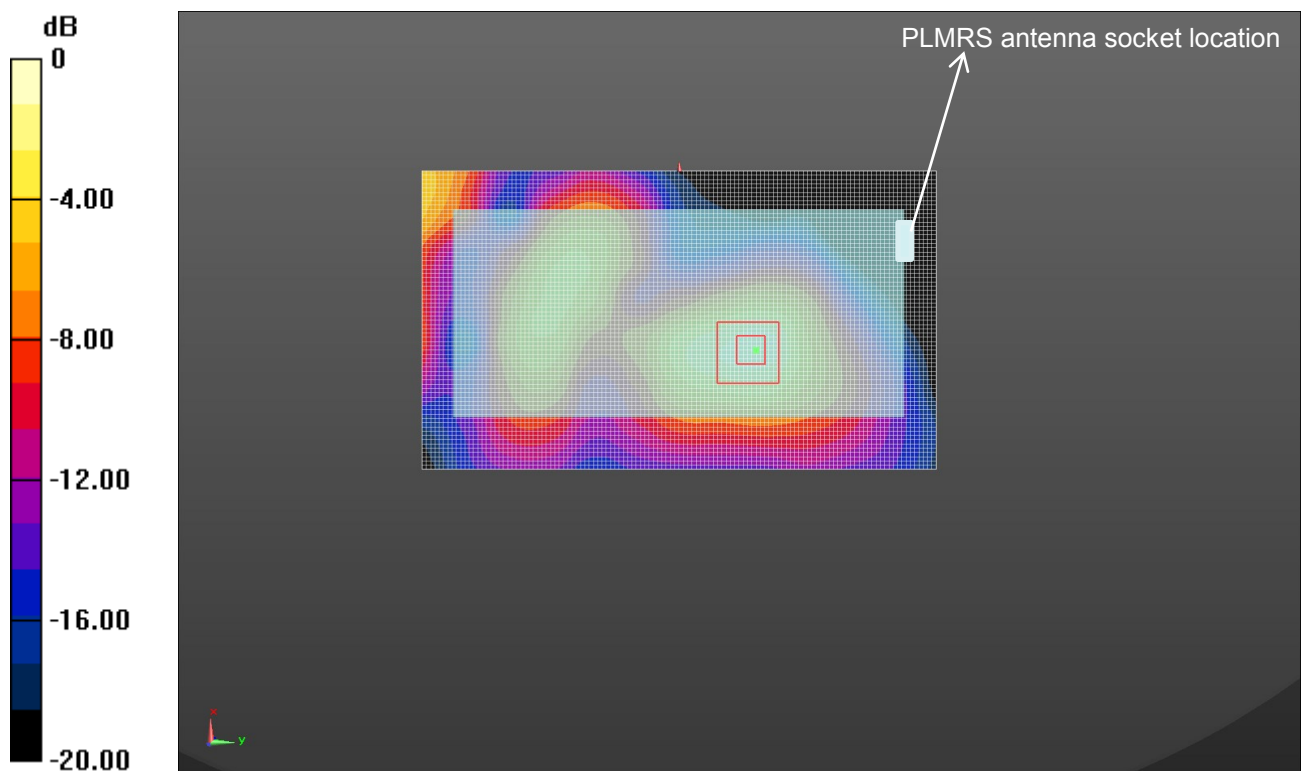

Body- worn Rear Side (LTE Band 7 Middle Channel)



Test mode: LTE Band 26      Test Position: Body- worn Rear Side      Test Plot: B7

Date: 2017-05-25

Communication System: Customer System; Frequency: 831.5 MHz; Duty Cycle:1:1

Medium parameters used (interpolated):  $f=831.5$  MHz;  $\sigma=0.96$ s/m;  $\epsilon=55.15$ ;  $\rho=1000$  kg/m<sup>3</sup>

Phantom section: Flat Section

**DASY5 Configuration:**

- Probe: ES3DV3 - SN3292; ConvF(6.27, 6.27, 6.27); Calibrated: 02/09/2016;
- Sensor-Surface: 4mm (Mechanical Surface Detection)
- Electronics: DAE4 Sn1315; Calibrated: 26/07/2016
- Phantom: SAM 1; Type: SAM;
- Measurement SW: DASY52, Version 52.8 (2); SEMCAD X Version 14.6.6 (6824)

**Area Scan (71x121x1):** Interpolated grid: dx=1.500 mm, dy=1.500 mm  
 Maximum value of SAR (interpolated) =0.181 W/kg

**Zoom Scan (7x7x7)/Cube 0:** Measurement grid: dx=5mm, dy=5mm, dz=5mm  
 Reference Value = 9.299 V/m; Power Drift = -0.04 dB  
 Peak SAR (extrapolated) = 0.197 mW/g  
**SAR(1 g) = 0.177 mW/g; SAR(10 g) = 0.158 mW/g**

Maximum value of SAR (measured) = 0.181 W/kg

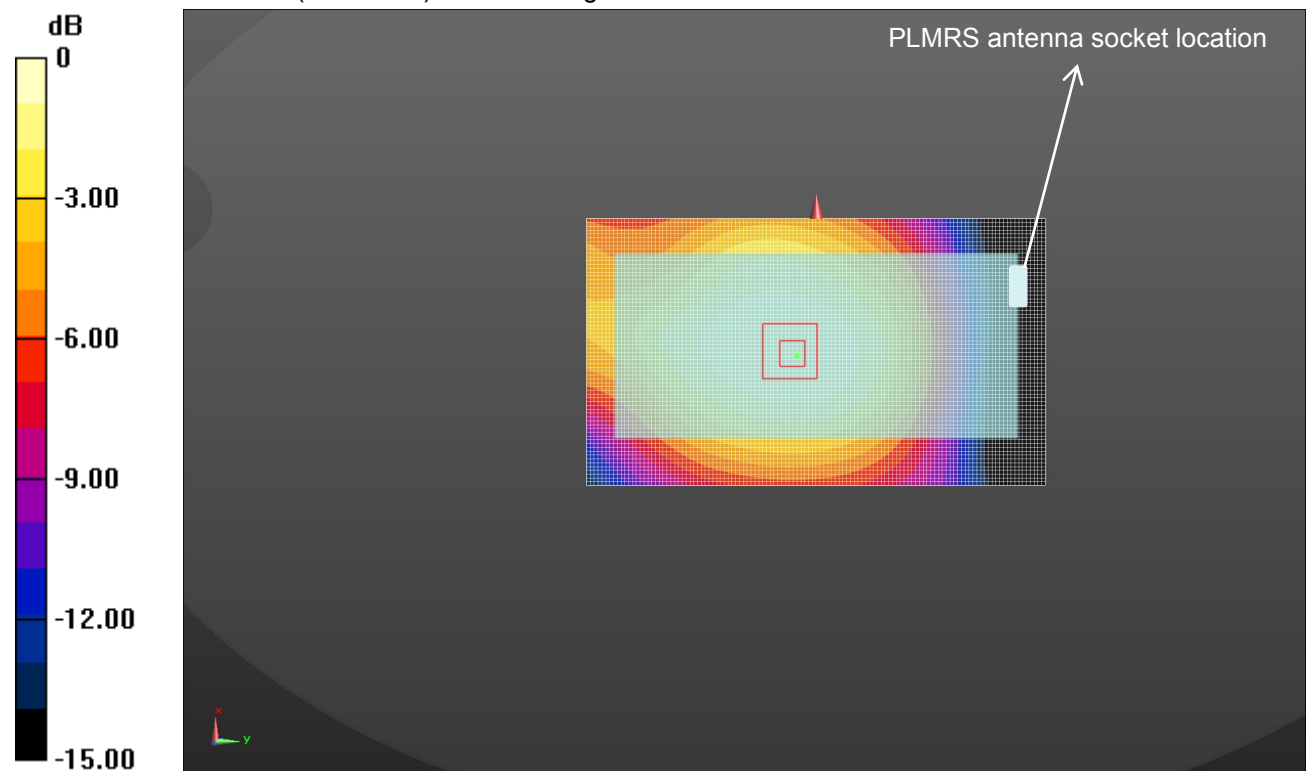

Body- worn Rear Side (LTE Band26 Middle Channel)

Test mode: LTE Band 41      Test Position: Body- worn Rear Side      Test Plot: B8

Date: 2017-06-15

Communication System: Generic LTE; Frequency: 2593 MHz; Duty Cycle: 1:1  
 Medium parameters used:  $f = 2593$  MHz;  $\sigma = 2.14$  s/m;  $\epsilon = 51.12$ ;  $\rho = 1000$  kg/m<sup>3</sup>  
 Phantom section: Flat Section

**DASY5 Configuration:**

- Probe: ES3DV3 - SN3292; ConvF(4.52,4.52,4.52); Calibrated: 02/09/2016;
- Sensor-Surface: 4mm (Mechanical Surface Detection)
- Electronics: DAE4 Sn1315; Calibrated: 26/07/2016
- Phantom: SAM 1; Type: SAM;
- Measurement SW: DASY52, Version 52.8 (2); SEMCAD X Version 14.6.6 (6824)

**Area Scan (71x121x1):** Interpolated grid: dx=1.500 mm, dy=1.500 mm  
 Maximum value of SAR (interpolated) = 0.166 W/kg

**Zoom Scan (7x7x7)/Cube 0:** Measurement grid: dx=5mm, dy=5mm, dz=5mm  
 Reference Value = 8.670 V/m; Power Drift = -0.15 dB  
 Peak SAR (extrapolated) = 0.220 mW/g  
**SAR(1 g) = 0.162 mW/g; SAR(10 g) = 0.132 mW/g**  
 Maximum value of SAR (measured) = 0.169 W/kg

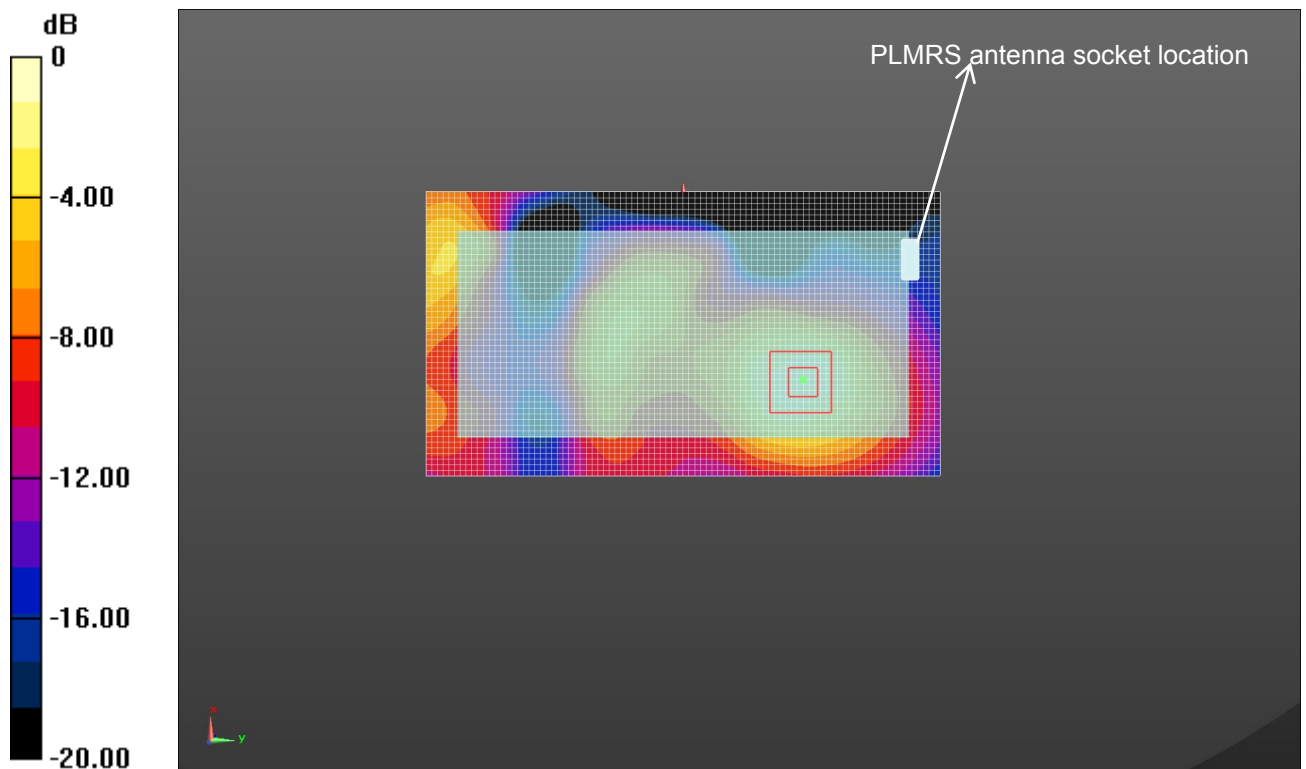

Body- worn Rear Side (LTE Band41 Middle Channel)

Test mode: WLAN 802.11b

Test Position: Body- worn Rear Side

Test Plot: B9

Date: 2017-06-10

Communication System: Customer System; Frequency: 2437.0 MHz; Duty Cycle:1:1

Medium parameters used (interpolated):  $f = 2437.0$  MHz;  $\sigma = 1.93$  S/m;  $\epsilon_r = 52.65$ ;  $\rho = 1000$  kg/m<sup>3</sup>

Phantom section : Flat Section

**DASY5 Configuration:**

- Probe: ES3DV3 - SN3292; ConvF(4.70,4.70,4.70); Calibrated: 02/09/2016;
- Sensor-Surface: 4mm (Mechanical Surface Detection)
- Electronics: DAE4 Sn1315; Calibrated: 26/07/2016
- Phantom: SAM 1; Type: SAM;
- Measurement SW: DASY52, Version 52.8 (2); SEMCAD X Version 14.6.6 (6824)

**Area Scan (71x121x1):** Interpolated grid: dx=1.500 mm, dy=1.500 mm  
 Maximum value of SAR (interpolated) = 0.139 W/kg

**Zoom Scan (7x7x7)/Cube 0:** Measurement grid: dx=5mm, dy=5mm, dz=5mm  
 Reference Value = 3.867 V/m; Power Drift = -0.19 dB  
 Peak SAR (extrapolated) = 0.247 mW/g

**SAR(1 g) = 0.134 mW/g; SAR(10 g) = 0.071 mW/g**

Maximum value of SAR (measured) = 0.143 W/kg

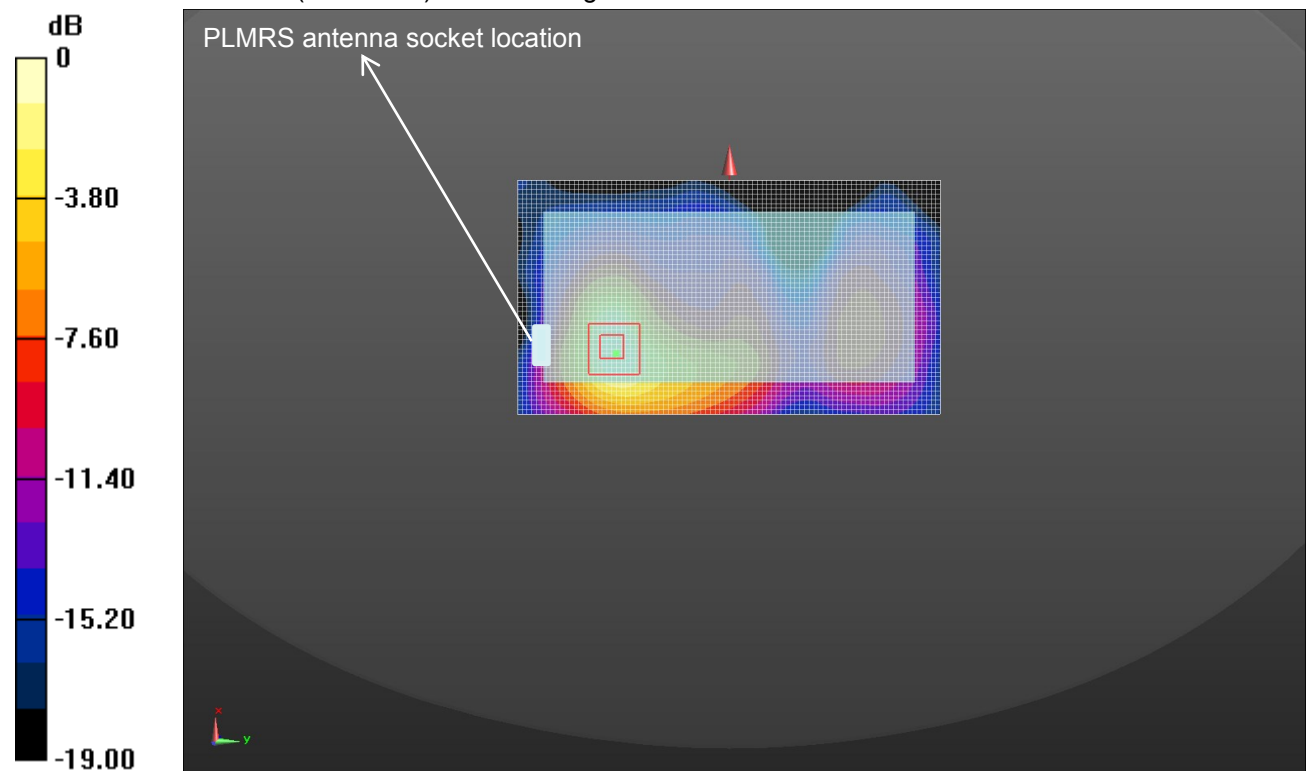

Body- worn Rear side (WLAN 802.11b Middle Channel)