

Operation Mode	Test Channel	Frequency Offset (kHz)	Measurement Power (dBc)	Limit (dB)	Result
TX2	CH _{L1}	-75	-78.16	≤-65	Pass
		-50	-76.75		
		-25	-63.69		
		25	-63.19	≤-55	
		50	-76.47		
		75	-76.79		
	CH _{M1}	-75	-78.85	≤-65	
		-50	-76.19		
		-25	-64.49		
		25	-64.26	≤-55	
		50	-75.52		
		75	-76.19		
	CH _{H1}	-75	-78.37	≤-65	
		-50	-76.36		
		-25	-64.48		
25		-63.52	≤-55		
50		-75.74			
75		-76.67			
TX2	CH _{L2}	-75	-78.34	≤-65	
		-50	-75.62		
		-25	-63.29		
		25	-63.18	≤-55	
		50	-75.69		
		75	-76.67		
	CH _{M2}	-75	-76.55	≤-65	
		-50	-75.84		
		-25	-64.69		
		25	-63.72	≤-55	
		50	-75.29		
		75	-76.67		
	CH _{H2}	-75	-78.56	≤-65	
		-50	-75.29		
		-25	-64.54		
25		-63.18	≤-55		
50		-75.46			
75		-76.89			

5.6. Spurious Emission on Antenna Port

Conducted spurious emissions are emissions at the antenna terminals on a frequency or frequencies that are outside a band sufficient to ensure transmission of information of required quality for the class of communication desired.

LIMIT

FCC Part 90.210 (25 kHz bandwidth only):

On any frequency removed from the center of the assigned channel by more than 250 percent at least:
 $43 + 10 \log (P_{\text{watts}})$

Calculation: Limit (dBm) = EL-43-10log₁₀ (TP)

Notes: EL is the emission level of the Output Power expressed in dBm,

Limit (dBm) = EL-43-10log₁₀ (TP) = -13 dBm

TEST CONFIGURATION

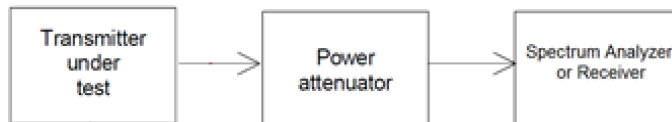

TEST PROCEDURE

1. The RF output of the EUT was connected to a spectrum analyzer through appropriate attenuation.
2. The resolution bandwidth of the spectrum analyzer was set to 100 kHz. Sufficient scans were taken to show any out of band emission up to 10th. Harmonic for the lower and the highest frequency range. Set RBW 100 kHz, VBW 300 kHz in the frequency band 30MHz to 1GHz, while set RBW=1MHz. VBW=3MHz from the 1GHz to 10th Harmonic.

TEST MODE:

Please reference to the section 2.4

TEST RESULTS

Passed Not Applicable

Test plot as follows:

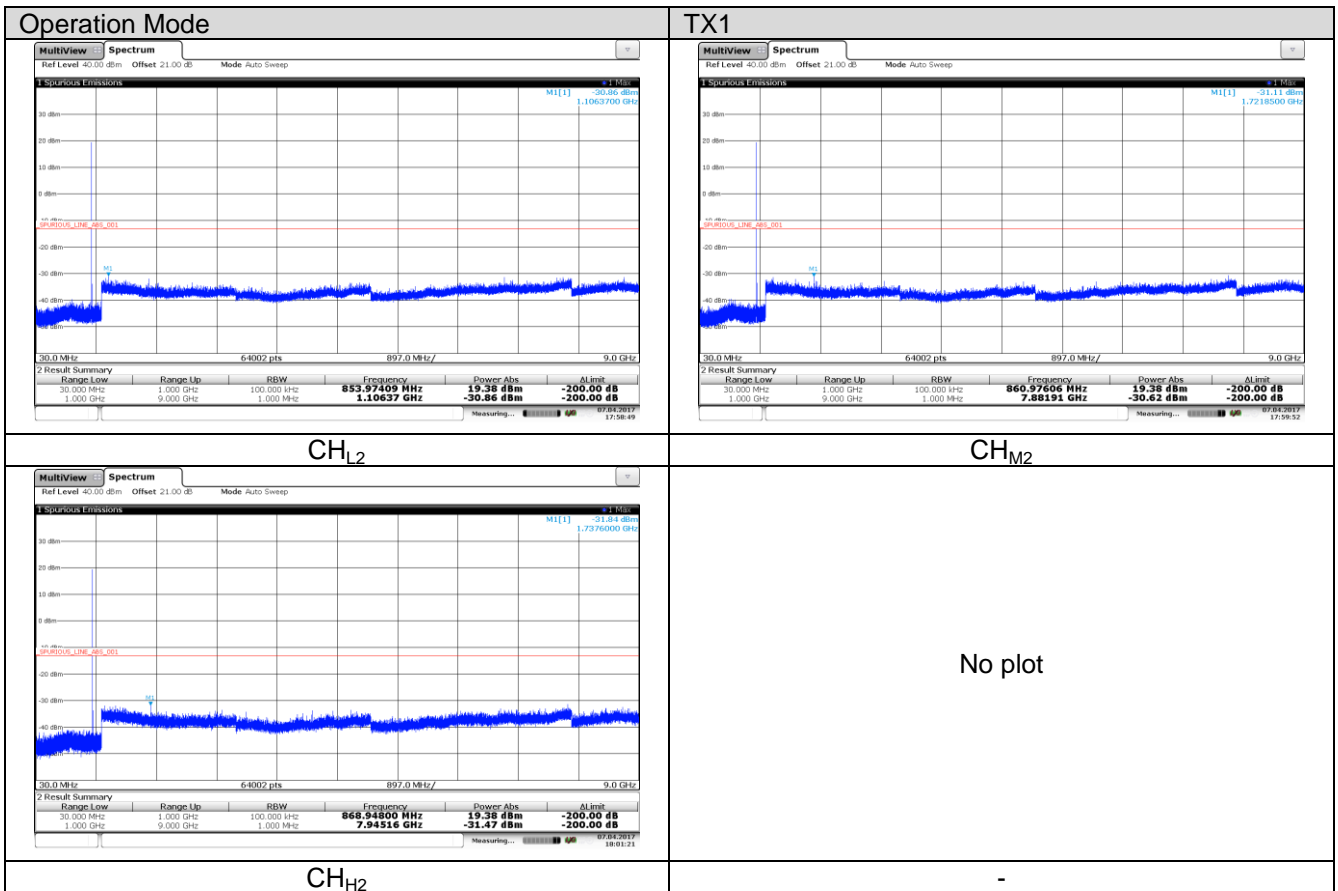
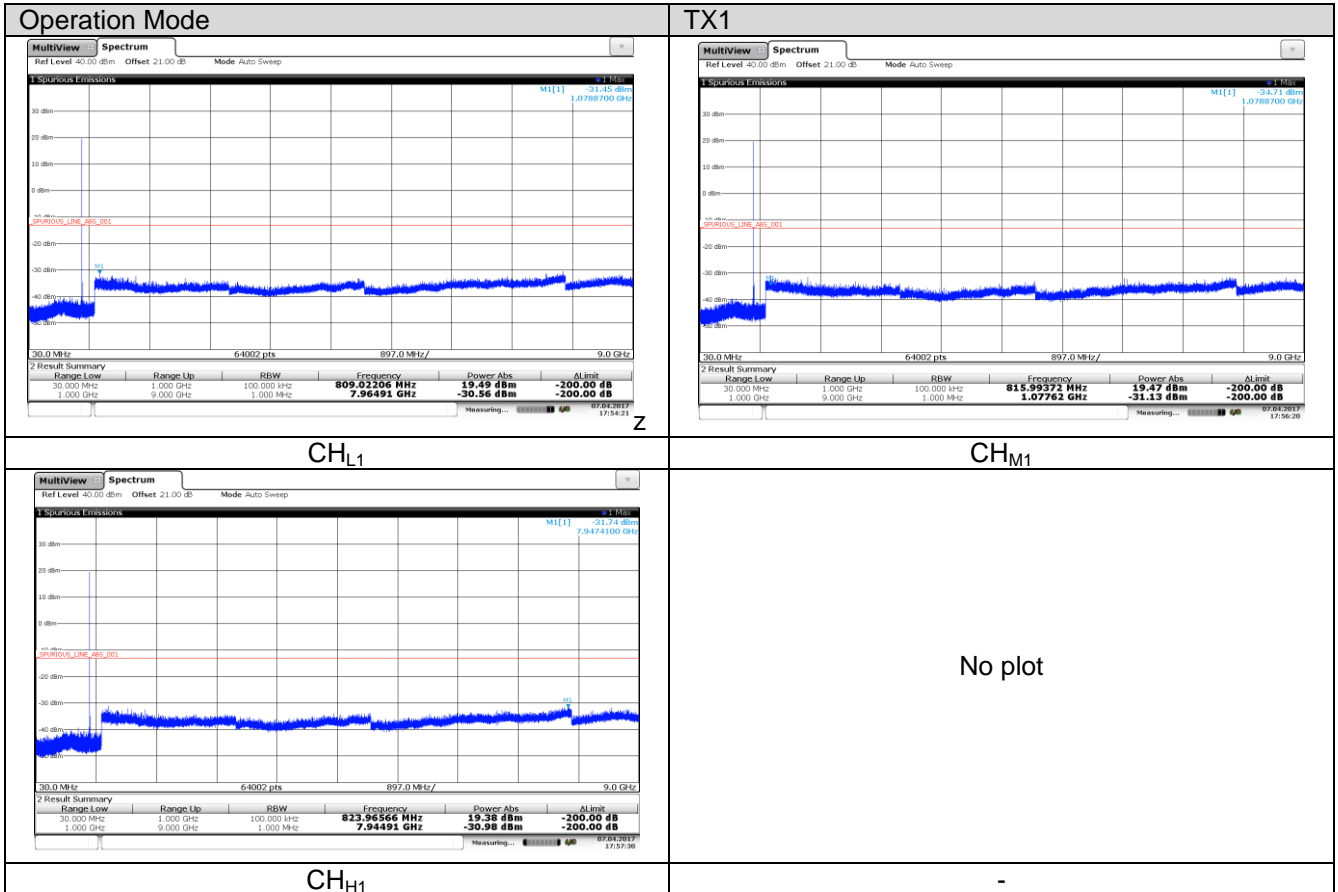

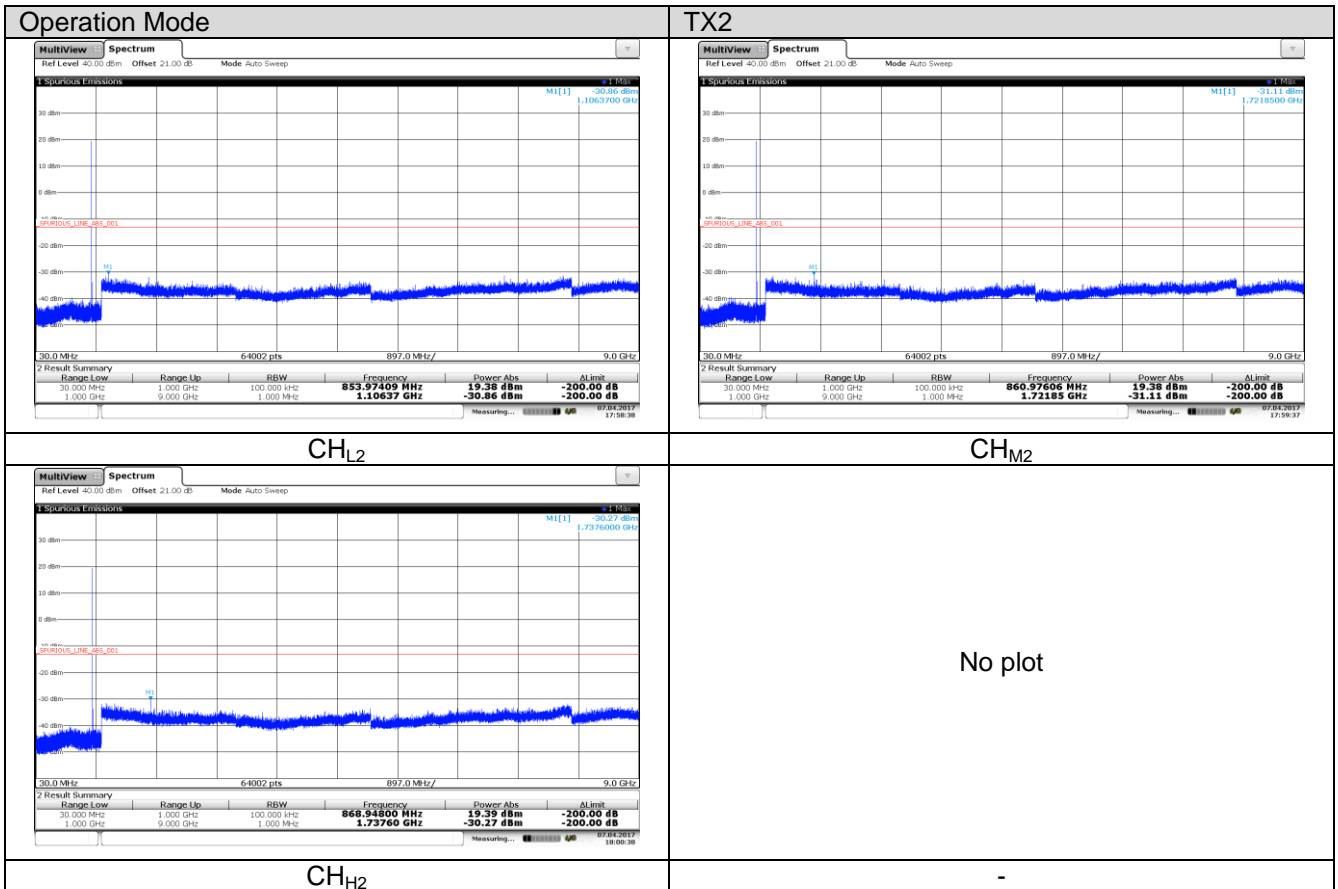
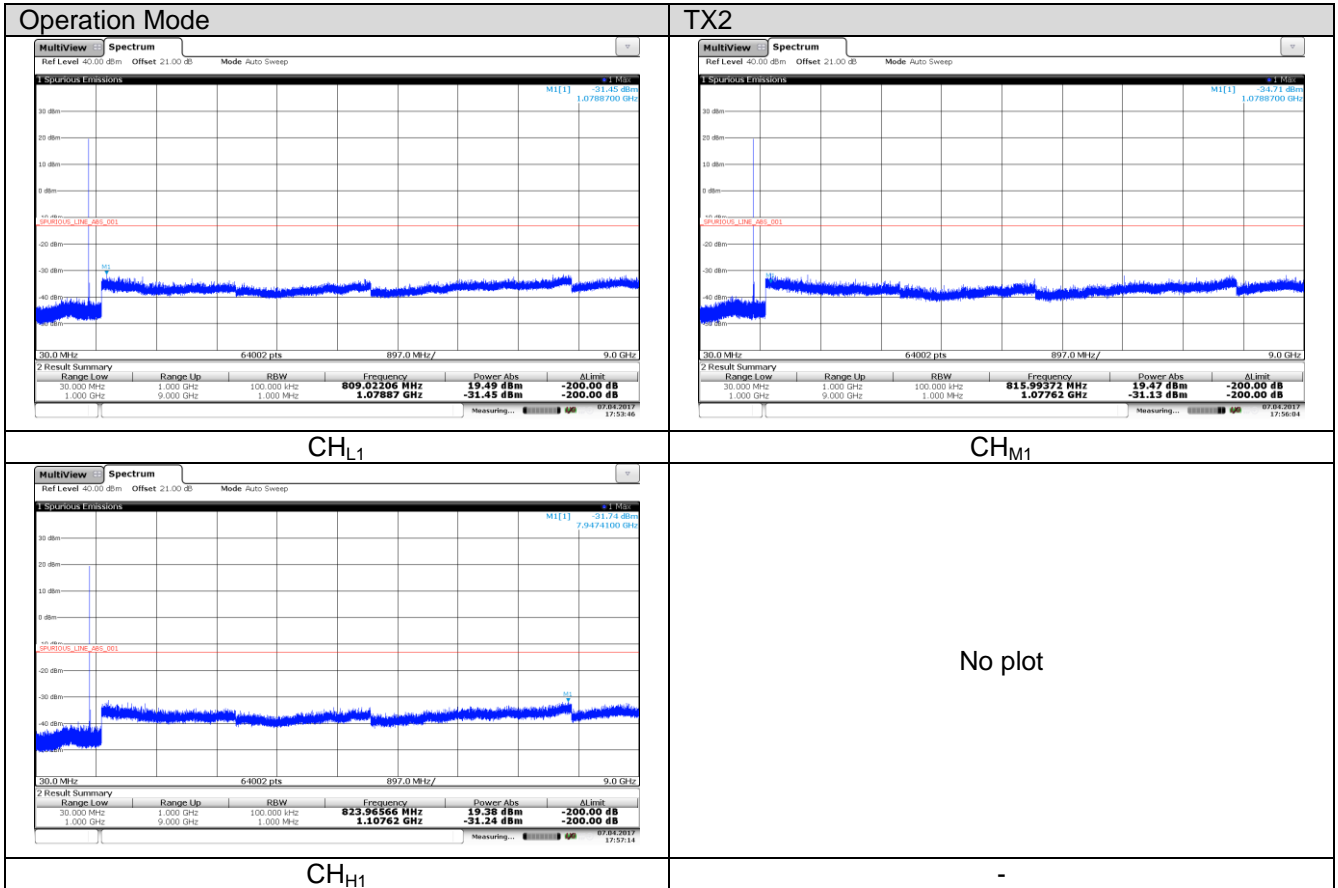

5.7. Radiated Spurious Emission

Radiated spurious emissions are emissions from the equipment when transmitting into a nonradiating load on a frequency or frequencies that are outside an occupied band sufficient to ensure transmission of information of required quality for the class of communications desired.

LIMIT

FCC Part 90.210 (25 kHz bandwidth only):

On any frequency removed from the center of the assigned channel by more than 250 percent at least:
 $43 + 10 \log(P_{watts})$

Calculation: Limit (dBm) = EL-43-10log₁₀ (TP)

Notes: EL is the emission level of the Output Power expressed in dBm,

Limit (dBm) = EL-43-10log₁₀ (TP) = -13 dBm

TEST CONFIGURATION

Below 1GHz:

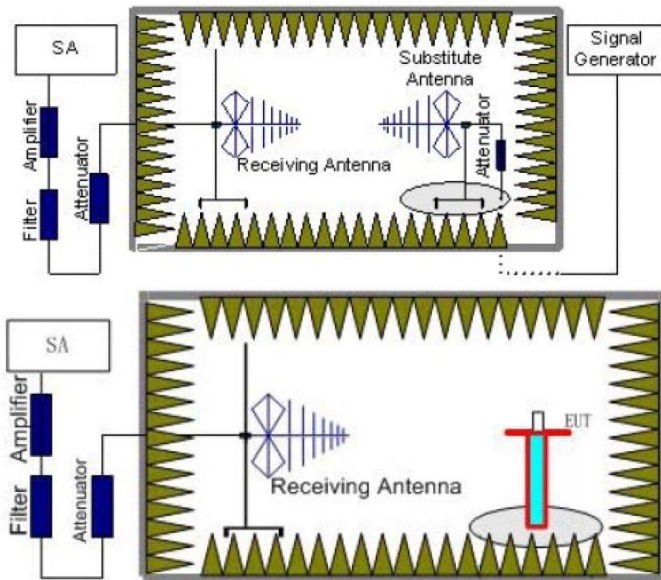

Above 1GHz:

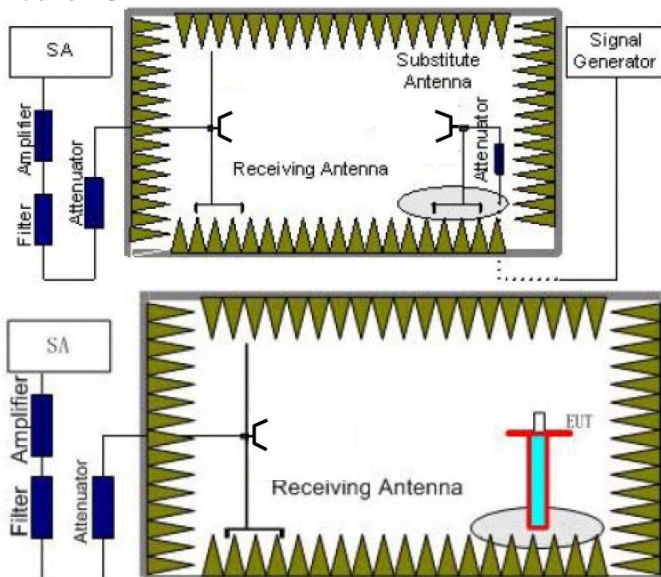

TEST PROCEDURE

1. EUT was placed on a 0.8 meter high non-conductive stand at a 3 meter test distance from the receive antenna. A receiving antenna was placed on the antenna mast 3 meters from the EUT for emission measurements. The height of receiving antenna is 1.0 m. Detected emissions were maximized at each frequency by rotating the EUT through 360° and adjusting the receiving antenna polarization. The radiated emission measurements of all transmit frequencies in six channels were measured with peak detector.
2. A log-periodic antenna or double-ridged waveguide horn antenna shall be substituted in place of the EUT. The log-periodic antenna will be driven by a signal generator and the level will be adjusted till the same power value on the spectrum analyzer or receiver. The level of the spurious emissions can be calculated through the level of the signal generator, cable loss, the gain of the substitution antenna and the reading of the spectrum analyzer or receiver.
3. The EUT is then put into continuously transmitting mode at its maximum power level during the test. Set Test Receiver or Spectrum RBW=1MHz,VBW=3MHz for above 1GHz and RBW=100kHz,VBW=300kHz for 30MHz to 1GHz, And the maximum value of the receiver should be recorded as (P_r).
4. The EUT shall be replaced by a substitution antenna. In the chamber, an substitution antenna for the frequency band of interest is placed at the reference point of the chamber. An RF Signal source for the frequency band of interest is connected to the substitution antenna with a cable that has been constructed to not interfere with the radiation pattern of the antenna. A power (P_{Mea}) is applied to the input of the substitution antenna, and adjust the level of the signal generator output until the value of the receiver reach the previously recorded (P_r). The power of signal source (P_{Mea}) is recorded. The test should be performed by rotating the test item and adjusting the receiving antenna polarization.
5. A amplifier should be connected to the Signal Source output port. And the cable should be connect between the Amplifier and the Substitution Antenna. The cable loss (P_{cl}), the Substitution Antenna Gain (G_a) and the Amplifier Gain (P_{Ag}) should be recorded after test. The measurement results are obtained as described below:

$$\text{Power(EIRP)} = P_{Mea} - P_{Ag} - P_{cl} - G_a$$
 We used SMF100A microwave signal generator which signal level can up to 33dBm,so we not used power Amplifier for substitution test; The measurement results are amend as described below:

$$\text{Power(EIRP)} = P_{Mea} - P_{cl} - G_a$$
6. This value is EIRP since the measurement is calibrated using an antenna of known gain (2.15 dBi) and known input power.
7. ERP can be calculated from EIRP by subtracting the gain of the dipole, $ERP = EIRP - 2.15\text{dBi}$.

TEST MODE:

Please reference to the section 2.4

TEST RESULTS

Passed Not Applicable

Test plot as follows:

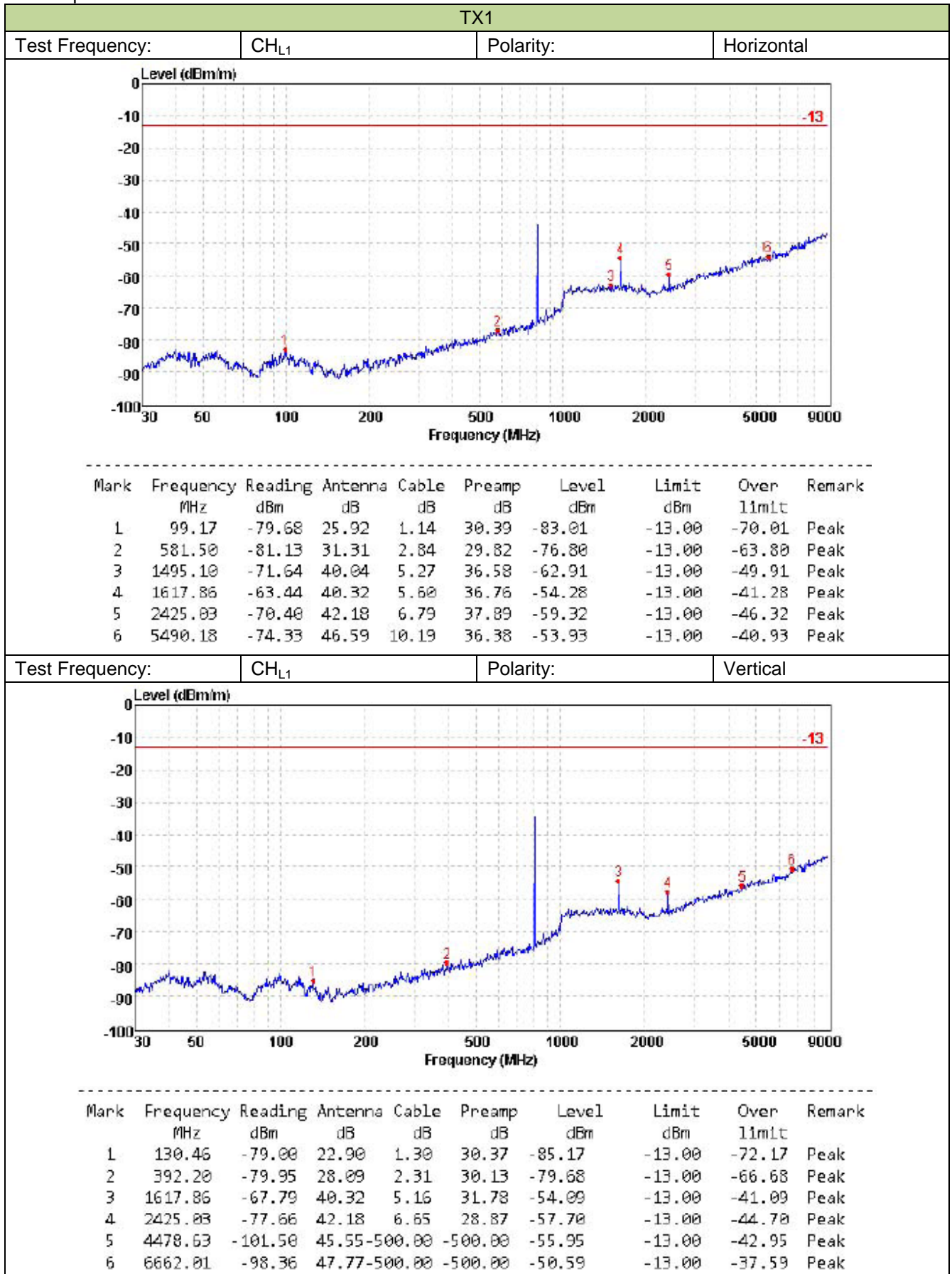

TX1

Test Frequency: CH_{M1} Polarity: Horizontal

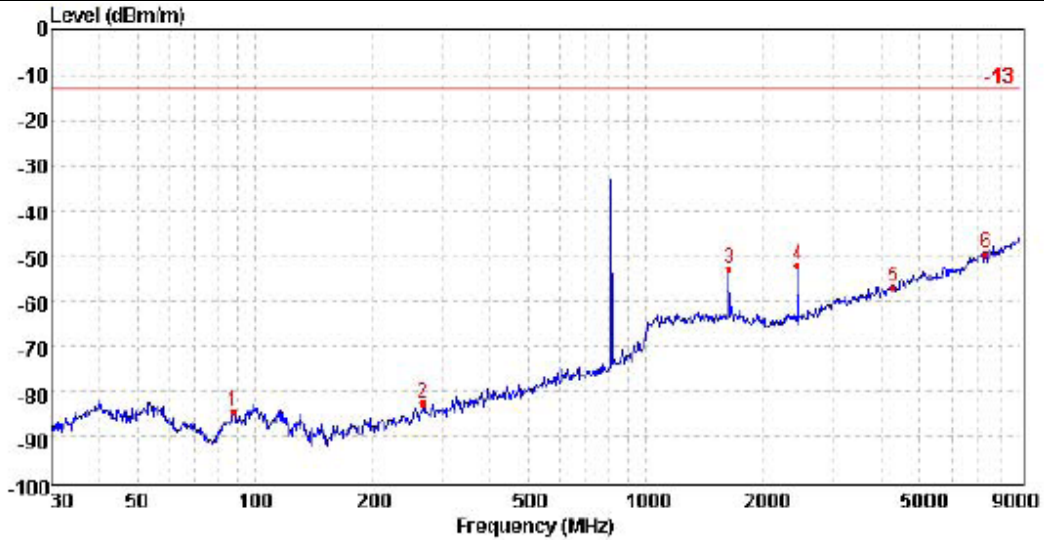

Mark	Frequency MHz	Reading dBm	Antenna dB	Cable dB	Preamp dB	Level dBm	Limit dBm	Over limit	Remark
1	87.99	-79.28	24.07	1.07	30.42	-84.56	-13.00	-71.56	Peak
2	269.21	-79.79	25.46	1.90	30.23	-82.66	-13.00	-69.66	Peak
3	1630.26	-62.03	40.34	5.63	36.78	-52.84	-13.00	-39.84	Peak
4	2449.85	-63.34	42.25	6.80	37.89	-52.18	-13.00	-39.18	Peak
5	4288.96	-73.44	45.21	9.02	37.61	-56.82	-13.00	-43.82	Peak
6	7338.62	-74.96	48.58	12.01	34.90	-49.27	-13.00	-36.27	Peak

Test Frequency: CH_{M1} Polarity: Vertical

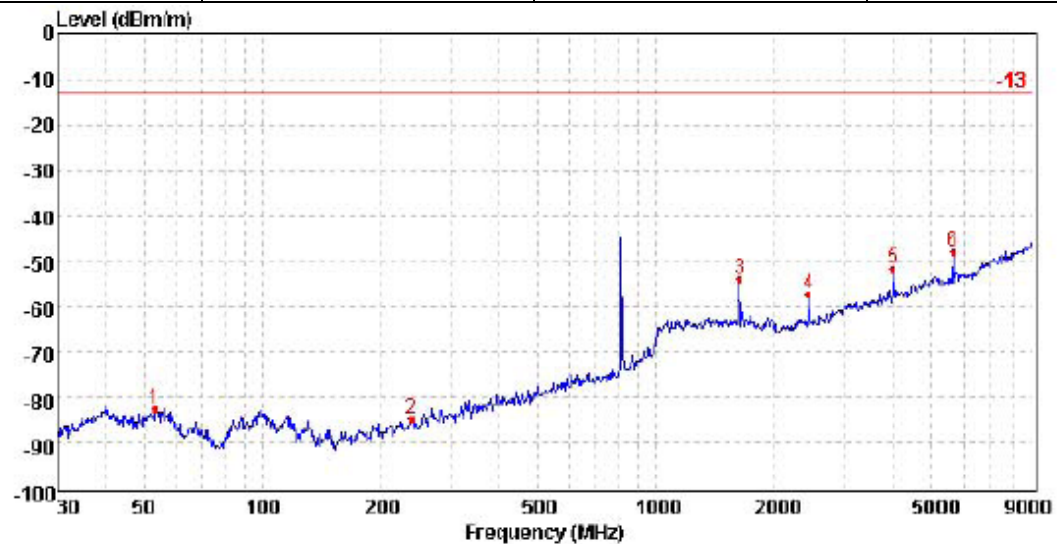

Mark	Frequency MHz	Reading dBm	Antenna dB	Cable dB	Preamp dB	Level dBm	Limit dBm	Over limit	Remark
1	53.22	-78.68	25.97	0.86	30.51	-82.36	-13.00	-69.36	Peak
2	238.04	-80.82	24.71	1.76	30.25	-84.60	-13.00	-71.60	Peak
3	1630.26	-67.43	40.34	5.17	31.92	-53.84	-13.00	-40.84	Peak
4	2449.85	-77.42	42.25	6.66	28.67	-57.18	-13.00	-44.18	Peak
5	4004.08	-96.46	44.73	-500.00	-500.00	-51.73	-13.00	-38.73	Peak
6	5631.73	-94.59	46.59	-500.00	-500.00	-48.00	-13.00	-35.00	Peak

TX1

Test Frequency: CH_{H1} Polarity: Horizontal

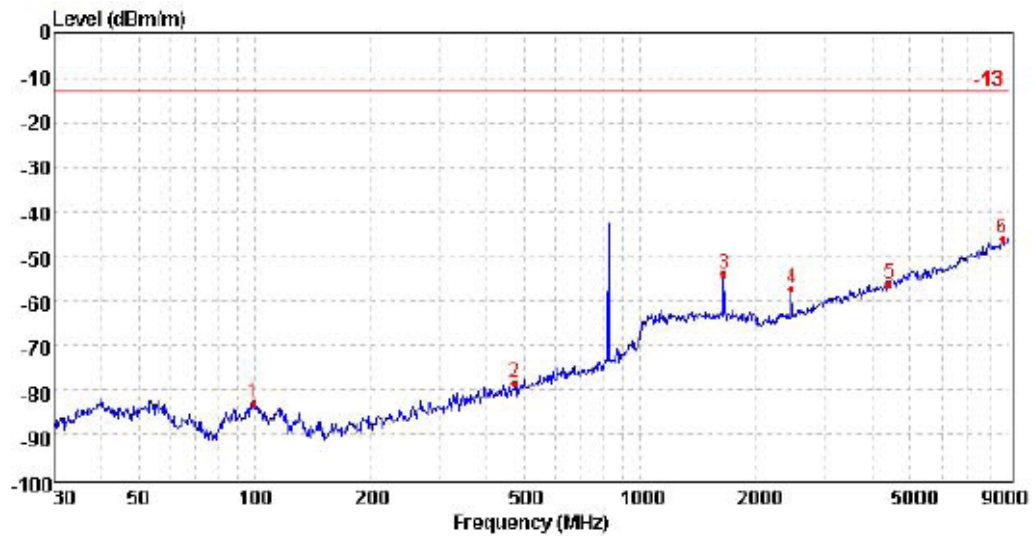

Mark	Frequency MHz	Reading dBm	Antenna dB	Cable dB	Preamp dB	Level dBm	Limit dBm	Over limit	Remark
1	99.17	-79.68	25.92	1.14	30.39	-83.01	-13.00	-70.01	Peak
2	472.55	-80.37	29.39	2.55	30.12	-78.55	-13.00	-65.55	Peak
3	1646.95	-63.18	40.38	5.66	36.82	-53.96	-13.00	-40.96	Peak
4	2468.63	-68.64	42.29	6.82	37.88	-57.41	-13.00	-44.41	Peak
5	4433.26	-73.33	45.45	9.18	37.51	-56.21	-13.00	-43.21	Peak
6	8615.13	-74.04	49.42	12.91	34.50	-46.21	-13.00	-33.21	Peak

Test Frequency: CH_{H1} Polarity: Vertical

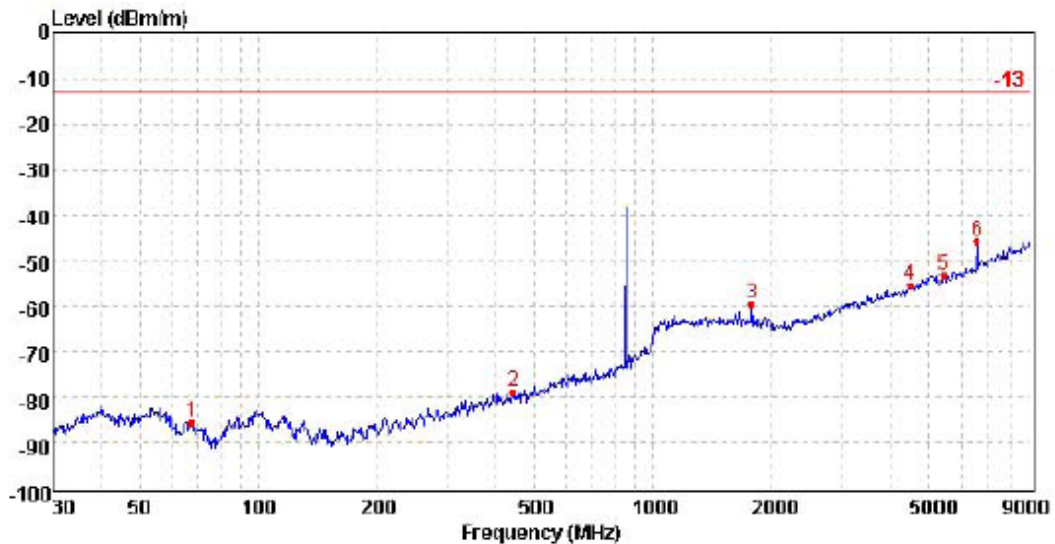

Mark	Frequency MHz	Reading dBm	Antenna dB	Cable dB	Preamp dB	Level dBm	Limit dBm	Over limit	Remark
1	67.59	-78.29	22.45	0.97	30.47	-85.34	-13.00	-72.34	Peak
2	442.01	-80.07	28.93	2.47	30.20	-78.87	-13.00	-65.87	Peak
3	1782.18	-75.01	40.66	5.48	30.59	-59.46	-13.00	-46.46	Peak
4	4501.49	-100.76	45.55	-500.00	-500.00	-55.21	-13.00	-42.21	Peak
5	5434.56	-99.63	46.60	-500.00	-500.00	-53.03	-13.00	-40.03	Peak
6	6577.75	-93.48	47.62	-500.00	-500.00	-45.86	-13.00	-32.86	Peak

TX1

Test Frequency: CH_{L2} Polarity: Horizontal

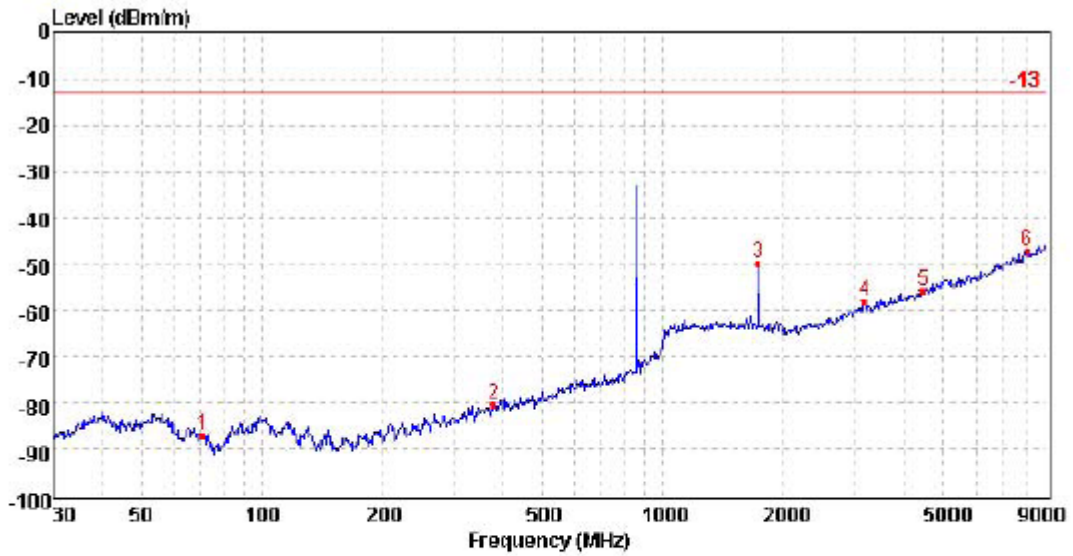

Mark	Frequency MHz	Reading dBm	Antenna dB	Cable dB	Preamp dB	Level dBm	Limit dBm	Over limit	Remark
1	71.00	-79.13	21.55	0.98	30.46	-87.06	-13.00	-74.06	Peak
2	378.65	-80.15	27.89	2.26	30.16	-80.16	-13.00	-67.16	Peak
3	1728.56	-59.15	40.54	5.82	36.99	-49.78	-13.00	-36.78	Peak
4	3192.37	-70.96	43.48	7.71	38.20	-57.99	-13.00	-44.99	Peak
5	4478.63	-73.33	45.55	9.26	37.43	-55.95	-13.00	-42.95	Peak
6	8063.40	-74.10	49.09	12.45	34.54	-47.10	-13.00	-34.10	Peak

Test Frequency: CH_{L2} Polarity: Vertical

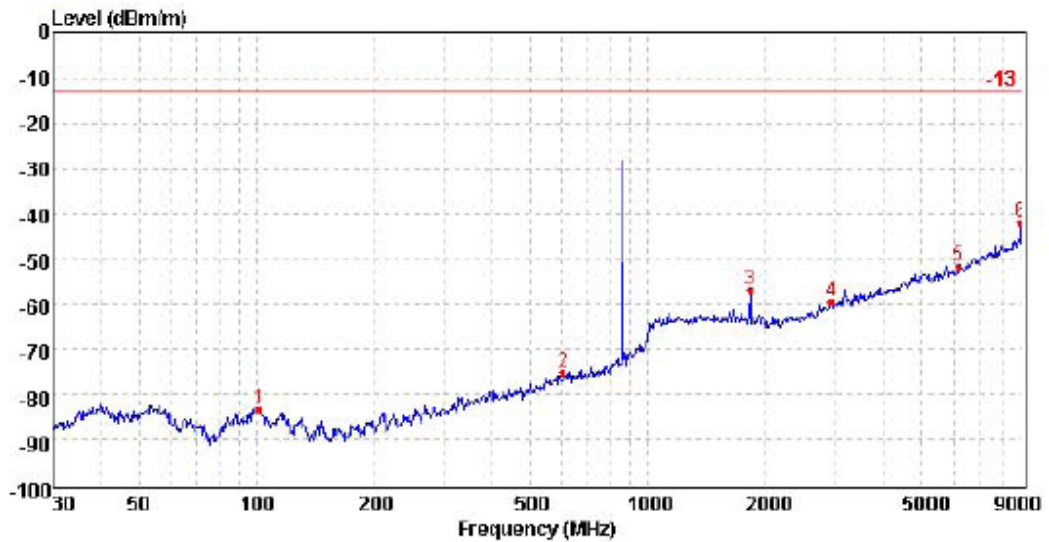

Mark	Frequency MHz	Reading dBm	Antenna dB	Cable dB	Preamp dB	Level dBm	Limit dBm	Over limit	Remark
1	101.64	-79.82	25.92	1.15	30.39	-83.14	-13.00	-70.14	Peak
2	606.57	-79.84	31.68	2.93	29.80	-75.03	-13.00	-62.03	Peak
3	1828.13	-73.08	40.73	5.61	29.99	-56.73	-13.00	-43.73	Peak
4	2950.14	-87.61	43.19	10.43	25.52	-59.51	-13.00	-46.51	Peak
5	6156.51	-98.50	46.88	-500.00	-500.00	-51.62	-13.00	-38.62	Peak
6	8927.68	-91.65	49.58	-500.00	-500.00	-42.07	-13.00	-29.07	Peak

TX1

Test Frequency: CH_{M2} Polarity: Horizontal

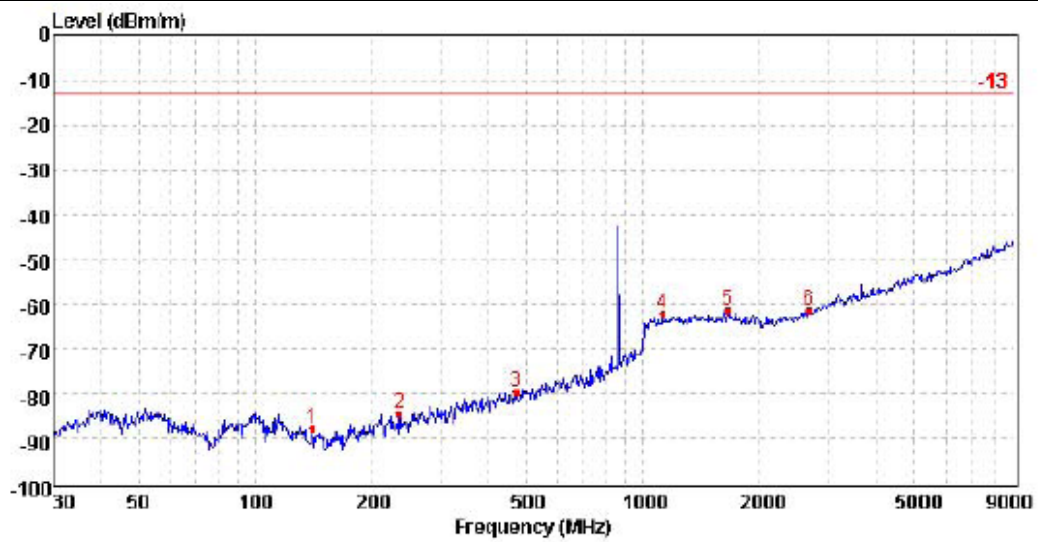

Mark	Frequency MHz	Reading dBm	Antenna dB	Cable dB	Preamp dB	Level dBm	Limit dBm	Over limit	Remark
1	139.55	-80.62	22.10	1.35	30.38	-87.55	-13.00	-74.55	Peak
2	234.84	-80.57	24.59	1.75	30.26	-84.49	-13.00	-71.49	Peak
3	471.02	-81.34	29.34	2.54	30.13	-79.59	-13.00	-66.59	Peak
4	1125.97	-75.57	38.84	4.14	29.65	-62.24	-13.00	-49.24	Peak
5	1658.61	-74.74	40.41	5.21	32.23	-61.35	-13.00	-48.35	Peak
6	2691.62	-84.49	42.73	7.31	26.88	-61.33	-13.00	-48.33	Peak

Test Frequency: CH_{M2} Polarity: Vertical

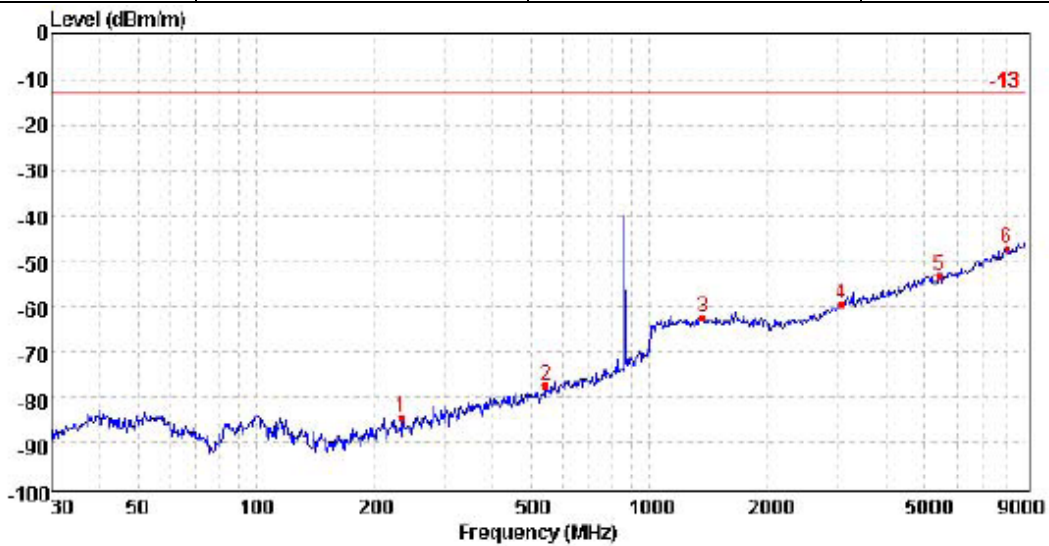

Mark	Frequency MHz	Reading dBm	Antenna dB	Cable dB	Preamp dB	Level dBm	Limit dBm	Over limit	Remark
1	233.89	-80.56	24.59	1.74	30.26	-84.49	-13.00	-71.49	Peak
2	545.84	-80.81	30.70	2.74	29.86	-77.23	-13.00	-64.23	Peak
3	1367.66	-77.14	39.65	4.66	29.53	-62.36	-13.00	-49.36	Peak
4	3000.60	-102.87	43.37-500.00	-500.00	-500.00	-59.50	-13.00	-46.50	Peak
5	5434.56	-99.63	46.60-500.00	-500.00	-500.00	-53.03	-13.00	-40.03	Peak
6	8063.40	-96.19	49.09-500.00	-500.00	-500.00	-47.10	-13.00	-34.10	Peak

TX1

Test Frequency: CH_{H2} Polarity: Horizontal

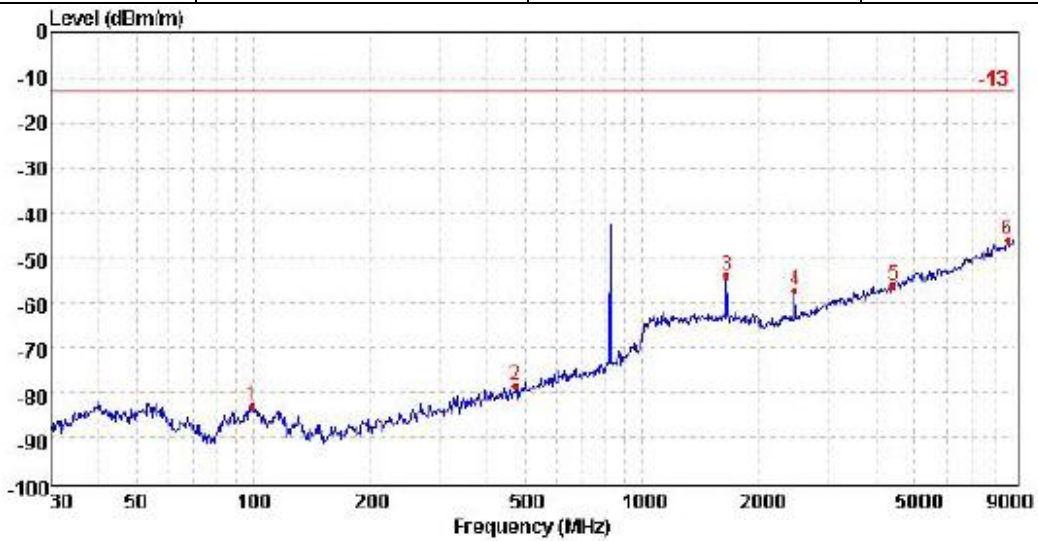

Mark	Frequency MHz	Reading dBm	Antenna dB	Cable dB	Preamp dB	Level dBm	Limit dBm	Over limit	Remark
1	99.17	-79.68	25.92	1.14	30.39	-83.01	-13.00	-70.01	Peak
2	472.55	-80.37	29.39	2.55	30.12	-78.55	-13.00	-65.55	Peak
3	1646.95	-63.18	40.38	5.66	36.82	-53.96	-13.00	-40.96	Peak
4	2468.63	-68.04	42.29	6.82	37.88	-57.41	-13.00	-44.41	Peak
5	4433.26	-73.33	45.45	9.18	37.51	-56.21	-13.00	-43.21	Peak
6	8615.13	-74.04	49.42	12.91	34.50	-46.21	-13.00	-33.21	Peak

Test Frequency: CH_{H2} Polarity: Vertical

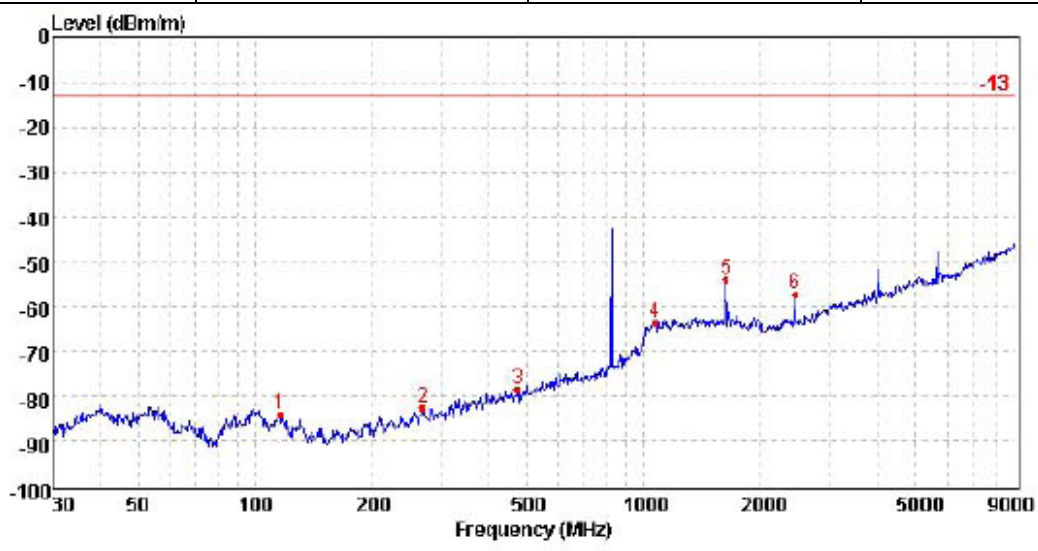

Mark	Frequency MHz	Reading dBm	Antenna dB	Cable dB	Preamp dB	Level dBm	Limit dBm	Over limit	Remark
1	115.68	-79.27	24.33	1.22	30.36	-84.08	-13.00	-71.08	Peak
2	269.91	-79.83	25.50	1.90	30.23	-82.66	-13.00	-69.66	Peak
3	473.88	-80.38	29.39	2.55	30.11	-78.55	-13.00	-65.55	Peak
4	1072.75	-76.67	38.62	4.03	29.61	-63.63	-13.00	-50.63	Peak
5	1628.76	-67.45	40.34	5.17	31.90	-53.84	-13.00	-40.84	Peak
6	2458.04	-77.48	42.25	6.66	28.61	-57.18	-13.00	-44.18	Peak

TX2

Test Frequency: CH_{L1} Polarity: Horizontal

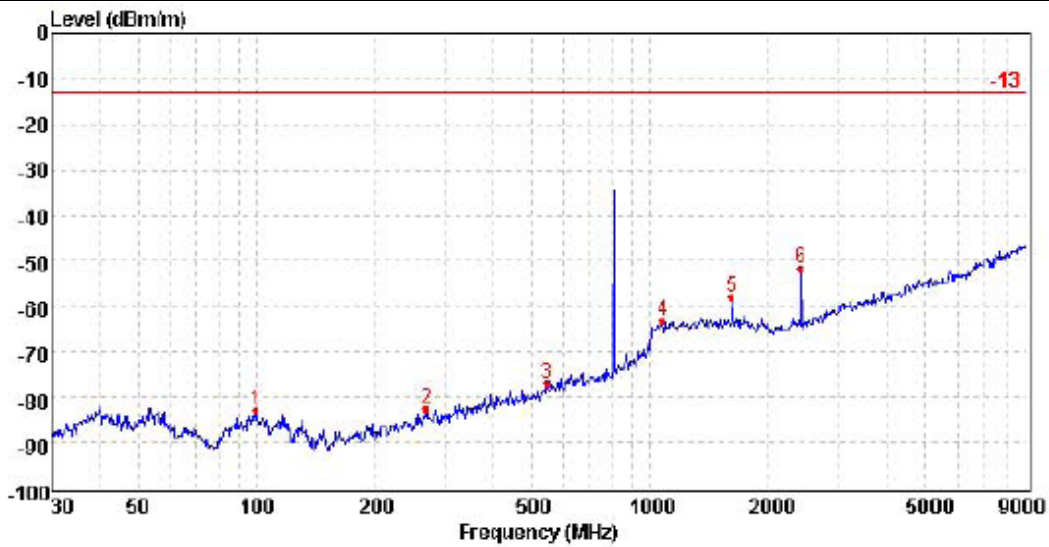

Mark	Frequency MHz	Reading dBm	Antenna dB	Cable dB	Preamp dB	Level dBm	Limit dBm	Over limit	Remark
1	99.44	-79.76	26.00	1.14	30.39	-83.01	-13.00	-70.01	Peak
2	269.91	-79.83	25.50	1.90	30.23	-82.66	-13.00	-69.66	Peak
3	547.96	-80.66	30.70	2.74	29.86	-77.08	-13.00	-64.08	Peak
4	1079.26	-76.31	38.65	4.04	29.62	-63.24	-13.00	-50.24	Peak
5	1618.94	-71.78	40.32	5.16	31.79	-58.09	-13.00	-45.09	Peak
6	2428.46	-71.72	42.21	6.65	28.84	-51.70	-13.00	-38.70	Peak

Test Frequency: CH_{L1} Polarity: Vertical

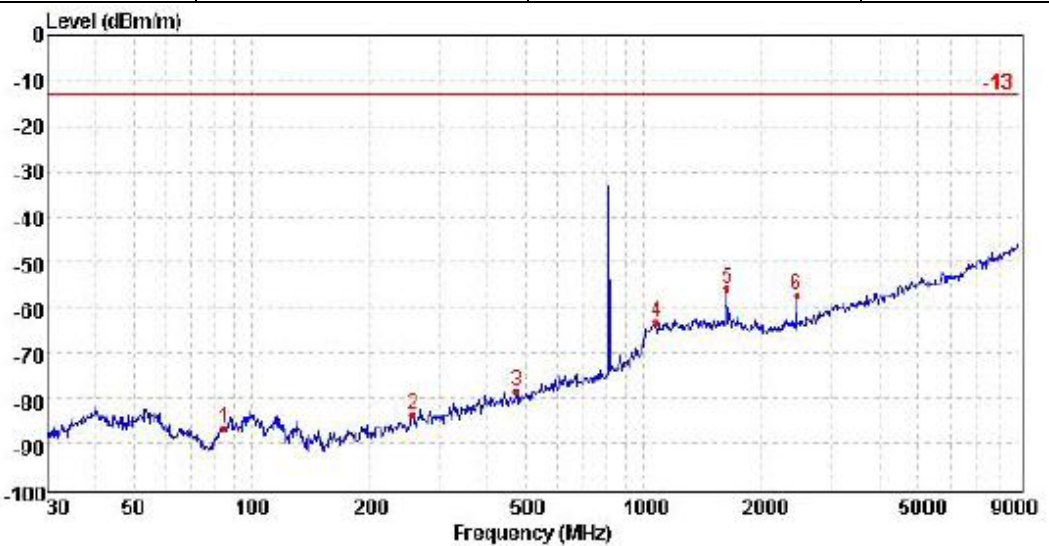

Mark	Frequency MHz	Reading dBm	Antenna dB	Cable dB	Preamp dB	Level dBm	Limit dBm	Over limit	Remark
1	84.96	-80.49	23.14	1.05	30.42	-86.72	-13.00	-73.72	Peak
2	257.16	-80.36	25.17	1.86	30.20	-83.53	-13.00	-70.53	Peak
3	473.83	-80.38	29.39	2.55	30.11	-78.55	-13.00	-65.55	Peak
4	1079.26	-76.31	38.65	4.04	29.62	-63.24	-13.00	-50.24	Peak
5	1628.76	-69.45	40.34	5.17	31.90	-55.84	-13.00	-42.84	Peak
6	2458.04	-77.48	42.25	6.66	28.61	-57.18	-13.00	-44.18	Peak

TX2

Test Frequency: CH_{M1} Polarity: Horizontal

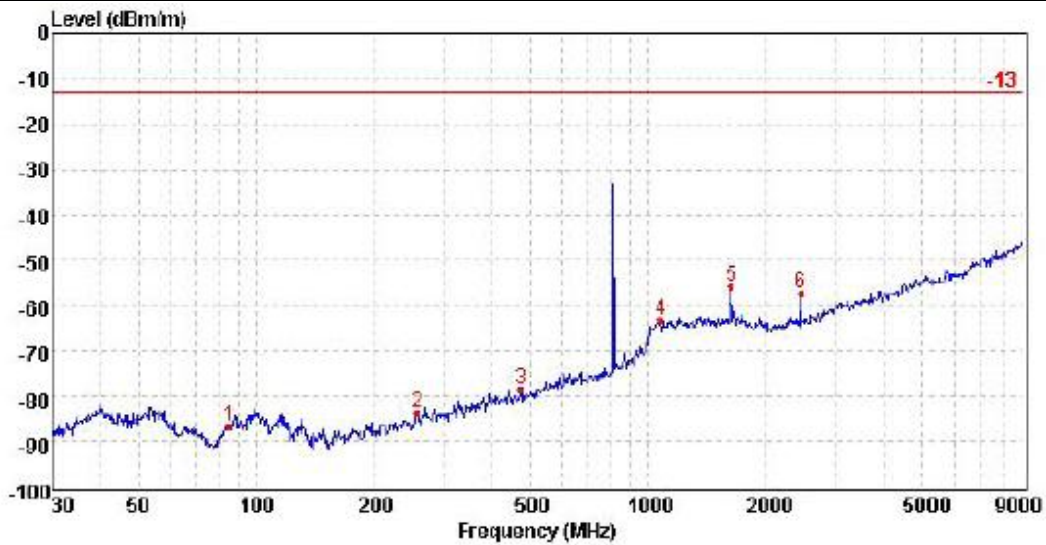

Mark	Frequency MHz	Reading dBm	Antenna dB	Cable dB	Preamp dB	Level dBm	Limit dBm	Over limit	Remark
1	84.96	-80.49	23.14	1.05	30.42	-86.72	-13.00	-73.72	Peak
2	257.16	-80.36	25.17	1.86	30.20	-83.53	-13.00	-70.53	Peak
3	473.88	-80.38	29.39	2.55	30.11	-78.55	-13.00	-65.55	Peak
4	1079.26	-76.31	38.65	4.04	29.62	-63.24	-13.00	-50.24	Peak
5	1628.76	-69.45	40.34	5.17	31.90	-55.84	-13.00	-42.84	Peak
6	2458.04	-77.48	42.25	6.66	28.61	-57.18	-13.00	-44.18	Peak

Test Frequency: CH_{M1} Polarity: Vertical

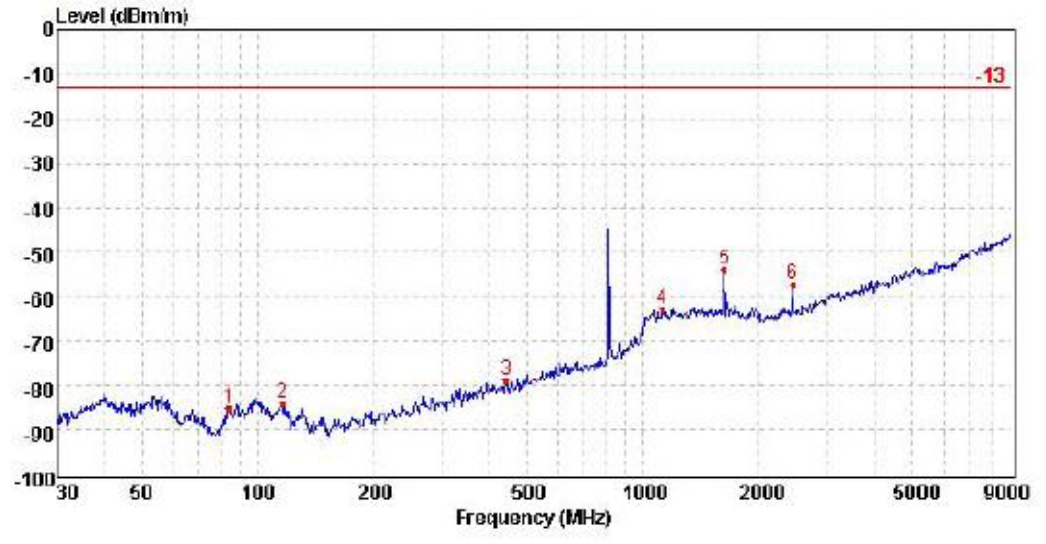

Mark	Frequency MHz	Reading dBm	Antenna dB	Cable dB	Preamp dB	Level dBm	Limit dBm	Over limit	Remark
1	83.94	-78.39	22.77	1.05	30.42	-84.99	-13.00	-71.99	Peak
2	115.68	-79.27	24.33	1.22	30.36	-84.06	-13.00	-71.06	Peak
3	443.36	-80.06	28.93	2.47	30.21	-78.87	-13.00	-65.87	Peak
4	1125.97	-76.04	38.84	4.14	29.65	-62.71	-13.00	-49.71	Peak
5	1628.76	-67.45	40.34	5.17	31.90	-53.84	-13.00	-40.84	Peak
6	2458.04	-77.48	42.25	6.66	28.61	-57.18	-13.00	-44.18	Peak

TX2

Test Frequency: CH_{H1} Polarity: Horizontal

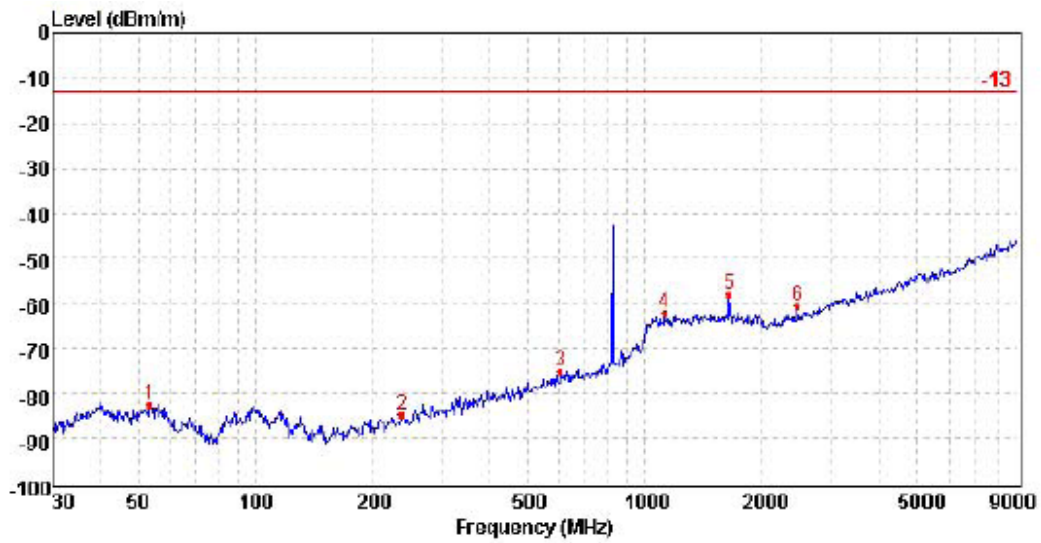

Mark	Frequency MHz	Reading dBm	Antenna dB	Cable dB	Preamp dB	Level dBm	Limit dBm	Over limit	Remark
1	53.31	-78.68	25.97	0.86	30.51	-82.36	-13.00	-69.36	Peak
2	237.70	-80.78	24.67	1.76	30.25	-84.60	-13.00	-71.60	Peak
3	607.34	-79.84	31.68	2.93	29.80	-75.03	-13.00	-62.03	Peak
4	1125.97	-75.57	38.84	4.14	29.65	-62.24	-13.00	-49.24	Peak
5	1648.60	-71.42	40.38	5.20	32.12	-57.96	-13.00	-44.96	Peak
6	2472.96	-80.88	42.29	6.67	28.49	-60.41	-13.00	-47.41	Peak

Test Frequency: CH_{H1} Polarity: Vertical

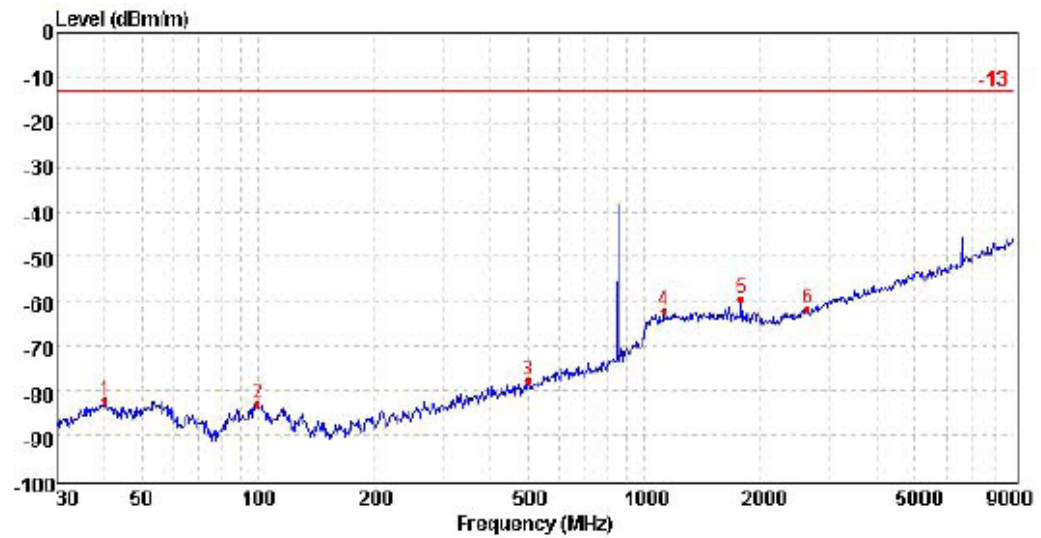

Mark	Frequency MHz	Reading dBm	Antenna dB	Cable dB	Preamp dB	Level dBm	Limit dBm	Over limit	Remark
1	40.11	-78.72	26.49	0.76	30.52	-81.99	-13.00	-68.99	Peak
2	99.44	-79.76	26.00	1.14	30.39	-83.01	-13.00	-70.01	Peak
3	500.41	-80.15	29.75	2.62	30.00	-77.78	-13.00	-64.78	Peak
4	1125.97	-75.57	38.84	4.14	29.65	-62.24	-13.00	-49.24	Peak
5	1783.54	-75.06	40.66	5.49	30.55	-59.46	-13.00	-46.46	Peak
6	2643.19	-84.25	42.63	7.22	27.32	-61.72	-13.00	-48.72	Peak

TX2

Test Frequency: CH_{L2} Polarity: Horizontal

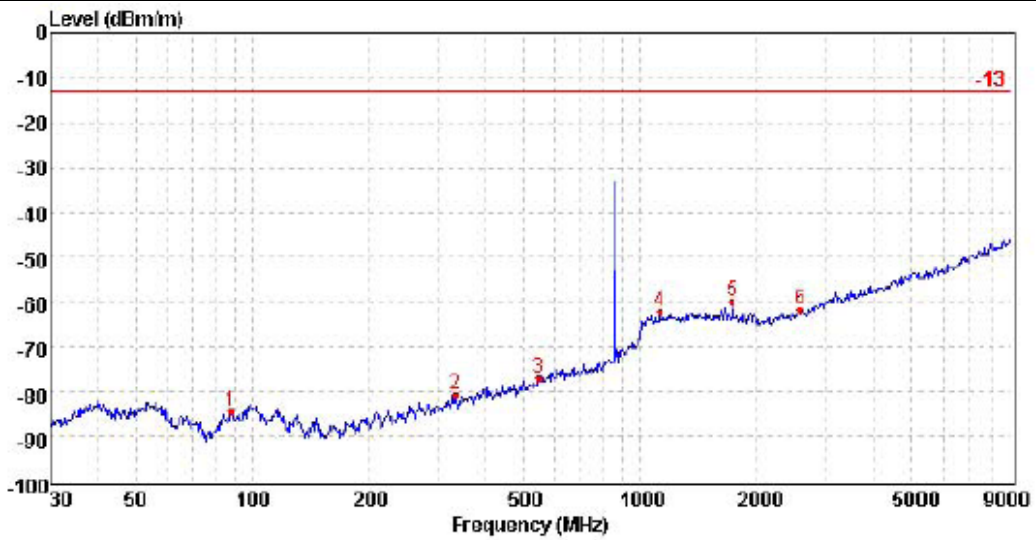

Mark	Frequency MHz	Reading dBm	Antenna dB	Cable dB	Preamp dB	Level dBm	Limit dBm	Over limit	Remark
1	88.10	-79.28	24.07	1.07	30.42	-84.56	-13.00	-71.56	Peak
2	333.60	-79.37	27.04	2.09	30.25	-80.49	-13.00	-67.49	Peak
3	547.96	-80.66	30.70	2.74	29.86	-77.08	-13.00	-64.08	Peak
4	1125.97	-75.57	38.84	4.14	29.65	-62.24	-13.00	-49.24	Peak
5	1730.38	-73.76	40.54	5.35	31.91	-59.78	-13.00	-46.78	Peak
6	2595.64	-83.49	42.57	7.11	27.74	-61.55	-13.00	-48.55	Peak

Test Frequency: CH_{L2} Polarity: Vertical

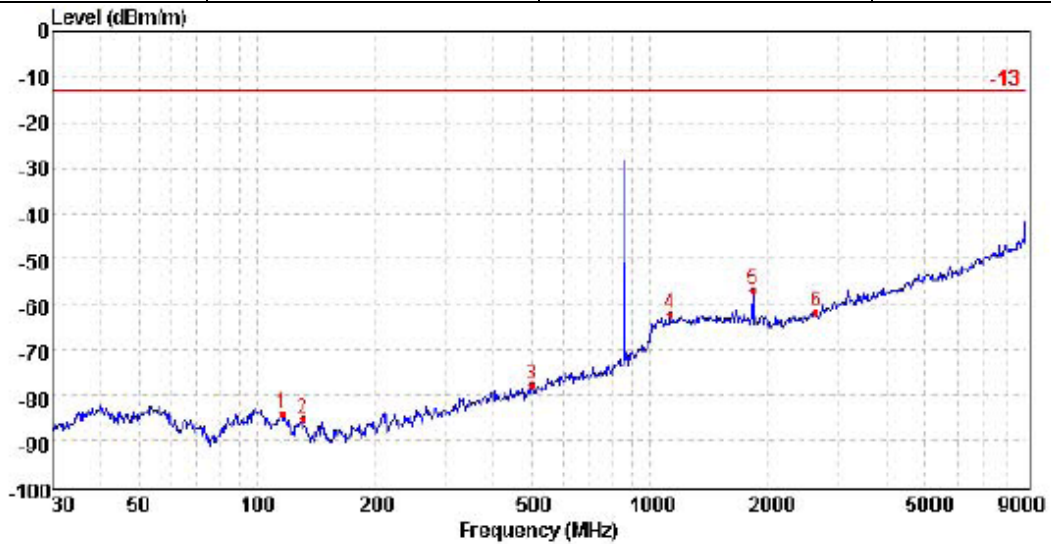

Mark	Frequency MHz	Reading dBm	Antenna dB	Cable dB	Preamp dB	Level dBm	Limit dBm	Over limit	Remark
1	115.68	-79.27	24.33	1.22	30.36	-84.08	-13.00	-71.08	Peak
2	130.56	-79.00	22.90	1.30	30.37	-85.17	-13.00	-72.17	Peak
3	500.41	-80.15	29.75	2.62	30.00	-77.78	-13.00	-64.78	Peak
4	1125.97	-75.57	38.84	4.14	29.65	-62.24	-13.00	-49.24	Peak
5	1827.25	-73.07	40.73	5.61	30.00	-56.73	-13.00	-43.73	Peak
6	2643.19	-84.25	42.63	7.22	27.32	-61.72	-13.00	-48.72	Peak

TX2

Test Frequency: CH_{M2} Polarity: Horizontal

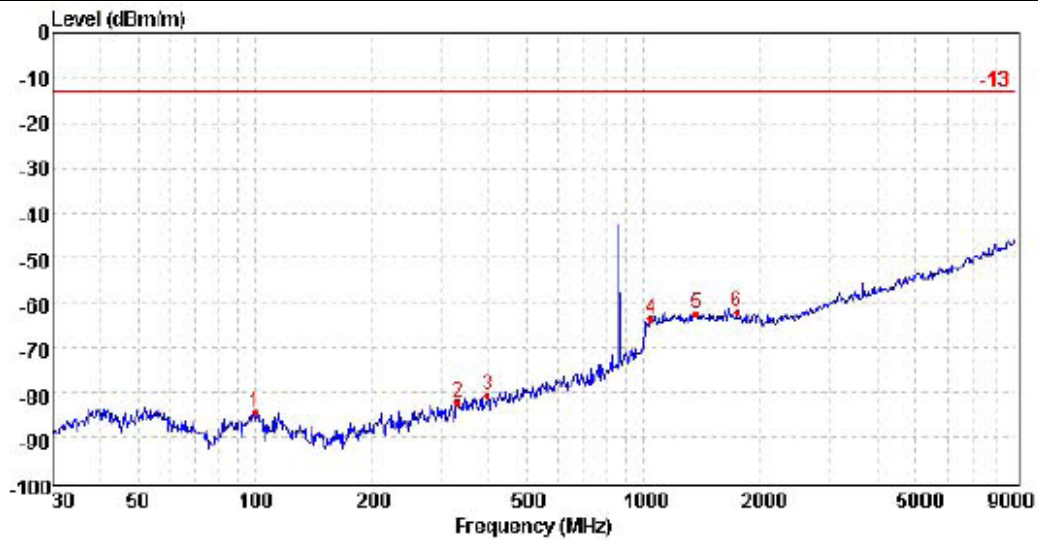

Mark	Frequency MHz	Reading dBm	Antenna dB	Cable dB	Preamp dB	Level dBm	Limit dBm	Over limit	Remark
1	100.04	-81.20	26.08	1.14	30.39	-84.37	-13.00	-71.37	Peak
2	331.58	-81.06	26.99	2.09	30.25	-82.23	-13.00	-69.23	Peak
3	397.60	-81.15	28.17	2.33	30.12	-80.77	-13.00	-67.77	Peak
4	1047.09	-76.46	38.54	3.99	29.57	-63.50	-13.00	-50.50	Peak
5	1366.58	-77.14	39.65	4.66	29.53	-62.36	-13.00	-49.36	Peak
6	1740.89	-76.56	40.57	5.38	31.64	-62.25	-13.00	-49.25	Peak

Test Frequency: CH_{M2} Polarity: Vertical

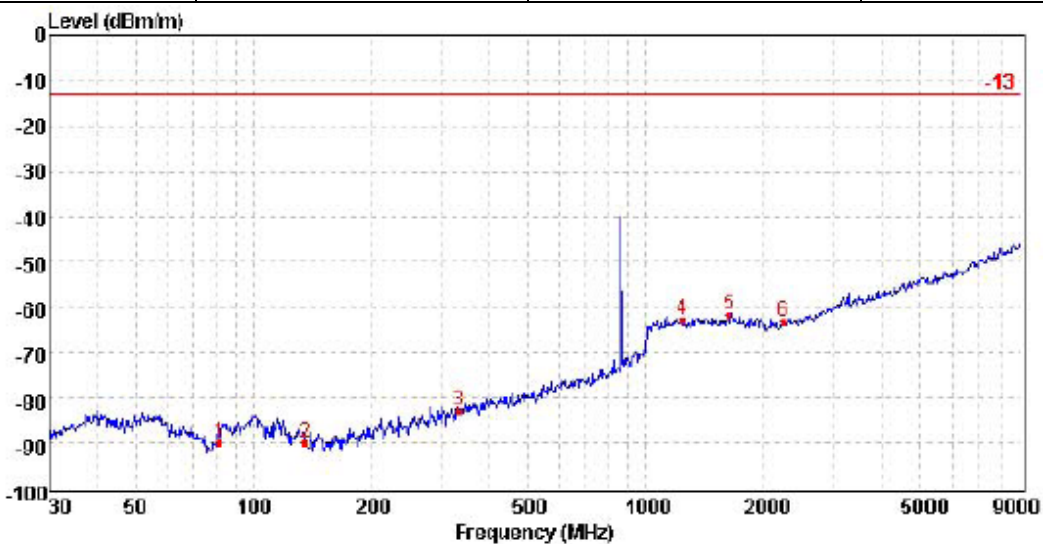

Mark	Frequency MHz	Reading dBm	Antenna dB	Cable dB	Preamp dB	Level dBm	Limit dBm	Over limit	Remark
1	81.43	-82.45	21.83	1.04	30.43	-90.01	-13.00	-77.01	Peak
2	135.39	-83.38	22.42	1.32	30.37	-90.01	-13.00	-77.01	Peak
3	333.60	-81.91	27.04	2.09	30.25	-83.03	-13.00	-70.03	Peak
4	1240.45	-76.93	39.23	4.39	29.60	-62.91	-13.00	-49.91	Peak
5	1628.76	-75.23	40.34	5.17	31.90	-61.62	-13.00	-48.62	Peak
6	2244.72	-81.55	41.75	6.20	29.75	-63.35	-13.00	-50.35	Peak

TX2

Test Frequency: CH_{H2} Polarity: Horizontal

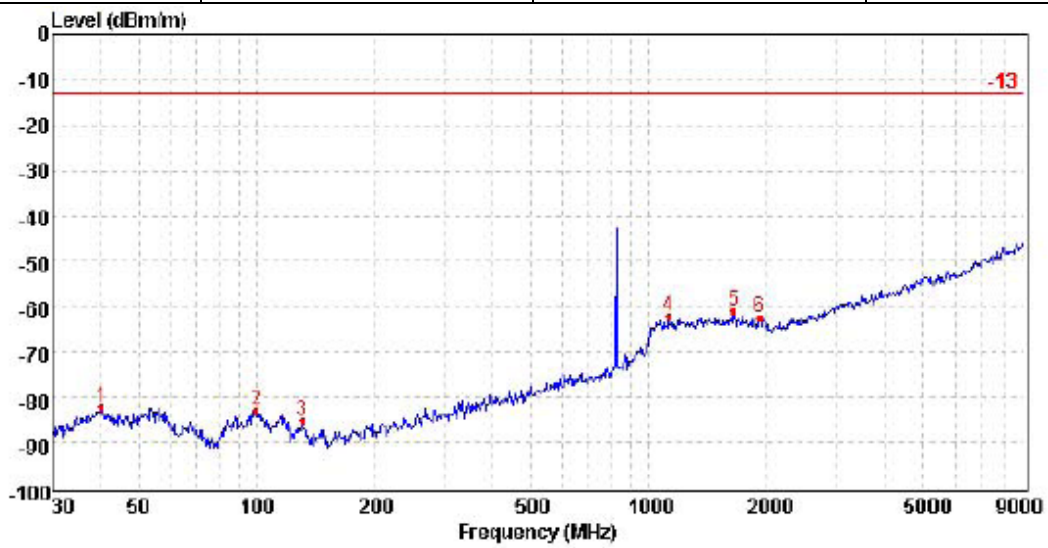

Mark	Frequency MHz	Reading dBm	Antenna dB	Cable dB	Preamp dB	Level dBm	Limit dBm	Over limit	Remark
1	40.11	-78.72	26.49	0.76	30.52	-81.99	-13.00	-68.99	Peak
2	99.44	-79.76	26.00	1.14	30.39	-83.01	-13.00	-70.01	Peak
3	130.56	-79.00	22.90	1.30	30.37	-85.17	-13.00	-72.17	Peak
4	1125.97	-75.57	38.84	4.14	29.65	-62.24	-13.00	-49.24	Peak
5	1648.60	-74.42	40.38	5.20	32.12	-60.96	-13.00	-47.96	Peak
6	1917.89	-79.44	40.91	5.84	29.71	-62.40	-13.00	-49.40	Peak

Test Frequency: CH_{H2} Polarity: Vertical

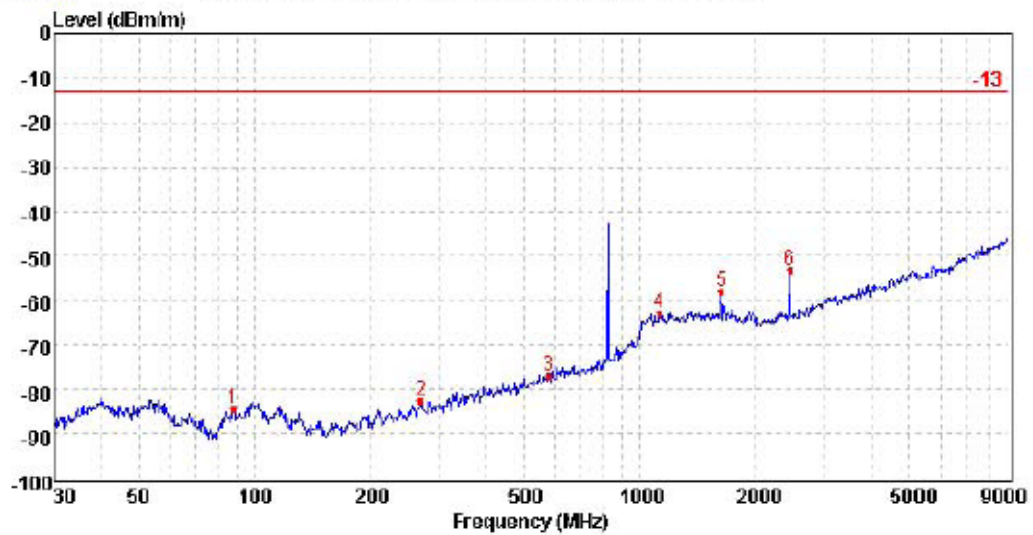

Mark	Frequency MHz	Reading dBm	Antenna dB	Cable dB	Preamp dB	Level dBm	Limit dBm	Over limit	Remark
1	88.10	-79.28	24.07	1.07	30.42	-84.56	-13.00	-71.56	Peak
2	269.91	-79.83	25.50	1.90	30.23	-82.66	-13.00	-69.66	Peak
3	582.15	-81.14	31.31	2.85	29.82	-76.80	-13.00	-63.80	Peak
4	1125.97	-76.04	38.84	4.14	29.65	-62.71	-13.00	-49.71	Peak
5	1628.76	-71.45	40.34	5.17	31.90	-57.84	-13.00	-44.84	Peak
6	2458.04	-73.48	42.25	6.66	28.61	-53.18	-13.00	-40.18	Peak

5.8. Conducted Emissions

Limit

FCC part 15.107(a)

Frequency of Emission (MHz)	Conducted Limit (dBμV)	
	Quasi-peak	Average
0.15-0.5	66 to 56*	56 to 46*
0.5-5	56	46
5-30	60	50

TEST CONFIGURATION

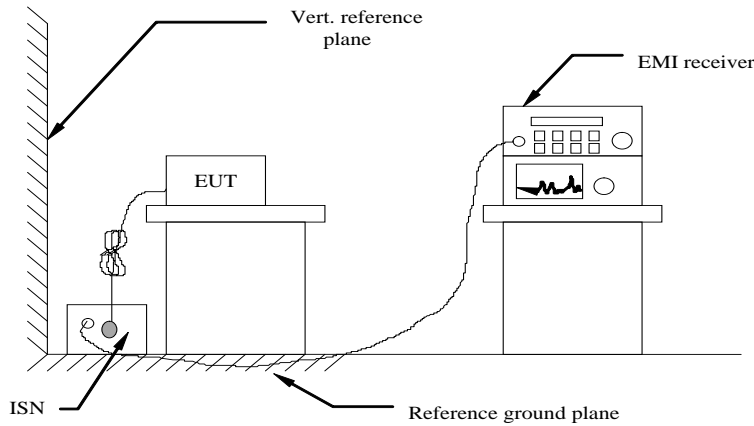

TEST PROCEDURE

- 1 The equipment was set up as per the test configuration to simulate typical actual usage per the user's manual. The EUT is a tabletop system; a wooden table with a height of 0.8 meters is used and is placed on the ground plane as per ANSI C63.4-2014.
- 2 Support equipment, if needed, was placed as per ANSI C63.4-2014.
- 3 All I/O cables were positioned to simulate typical actual usage as per ANSI C63.4-2014.
- 4 If a EUT received AC120V/60Hz power through a Line Impedance Stabilization Network (LISN) which supplied power source and was grounded to the ground plane.
- 5 All support equipments received AC power from a second LISN, if any
- 6 The EUT test program was started. Emissions were measured on each current carrying line of the EUT using a spectrum Analyzer / Receiver connected to the LISN powering the EUT. The LISN has two monitoring points: Line 1 (Hot Side) and Line 2 (Neutral Side). Two scans were taken: one with Line 1 connected to Analyzer / Receiver and Line 2 connected to a 50 ohm load; the second scan had Line 1 connected to a 50 ohm load and Line 2 connected to the Analyzer / Receiver.
- 7 Analyzer / Receiver scanned from 150 kHz to 30MHz for emissions in each of the test modes.
- 8 During the above scans, the emissions were maximized by cable manipulation.

TEST MODE:

Please reference to the section 2.4

TEST RESULTS

Passed **Not Applicable**

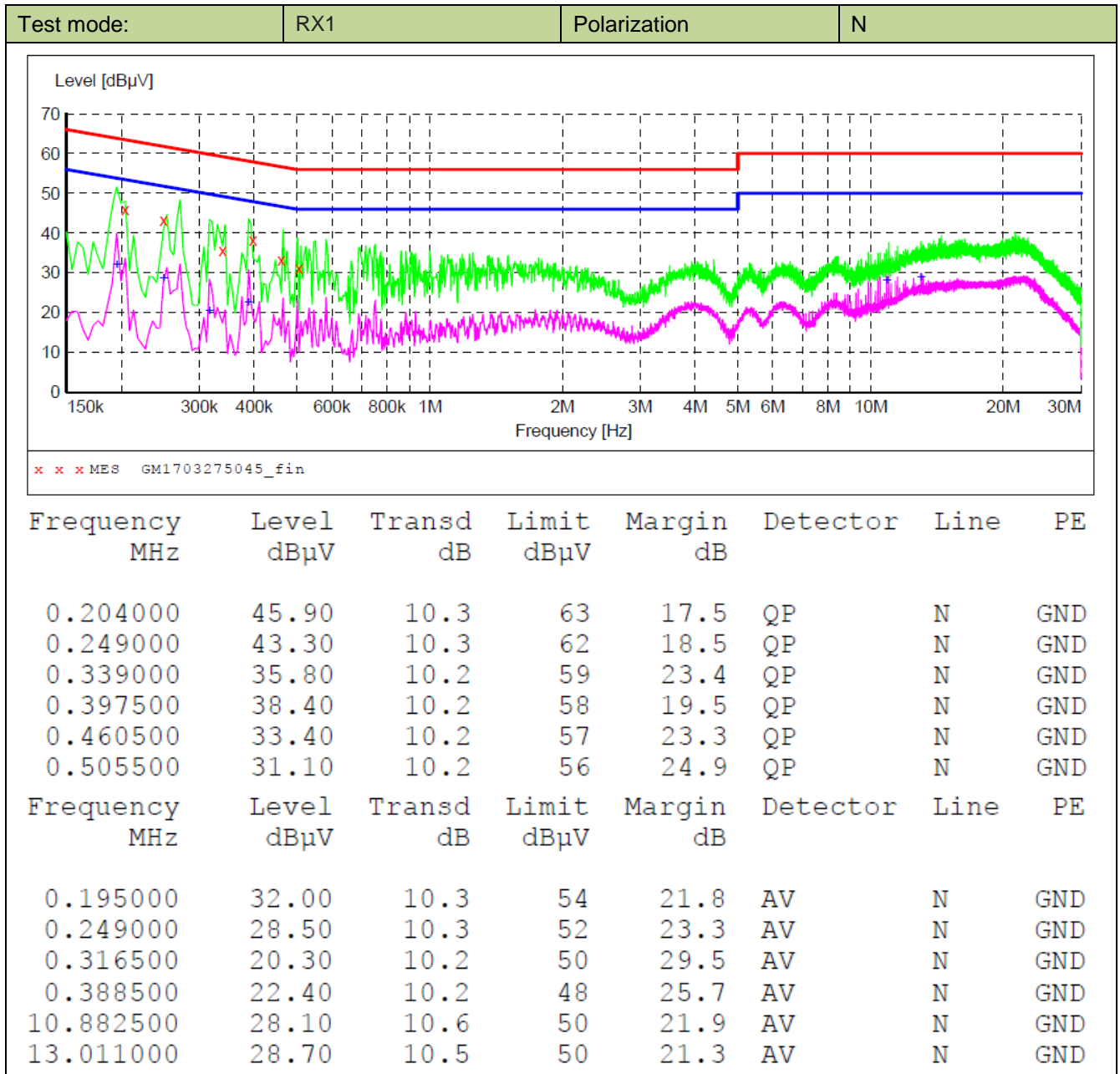

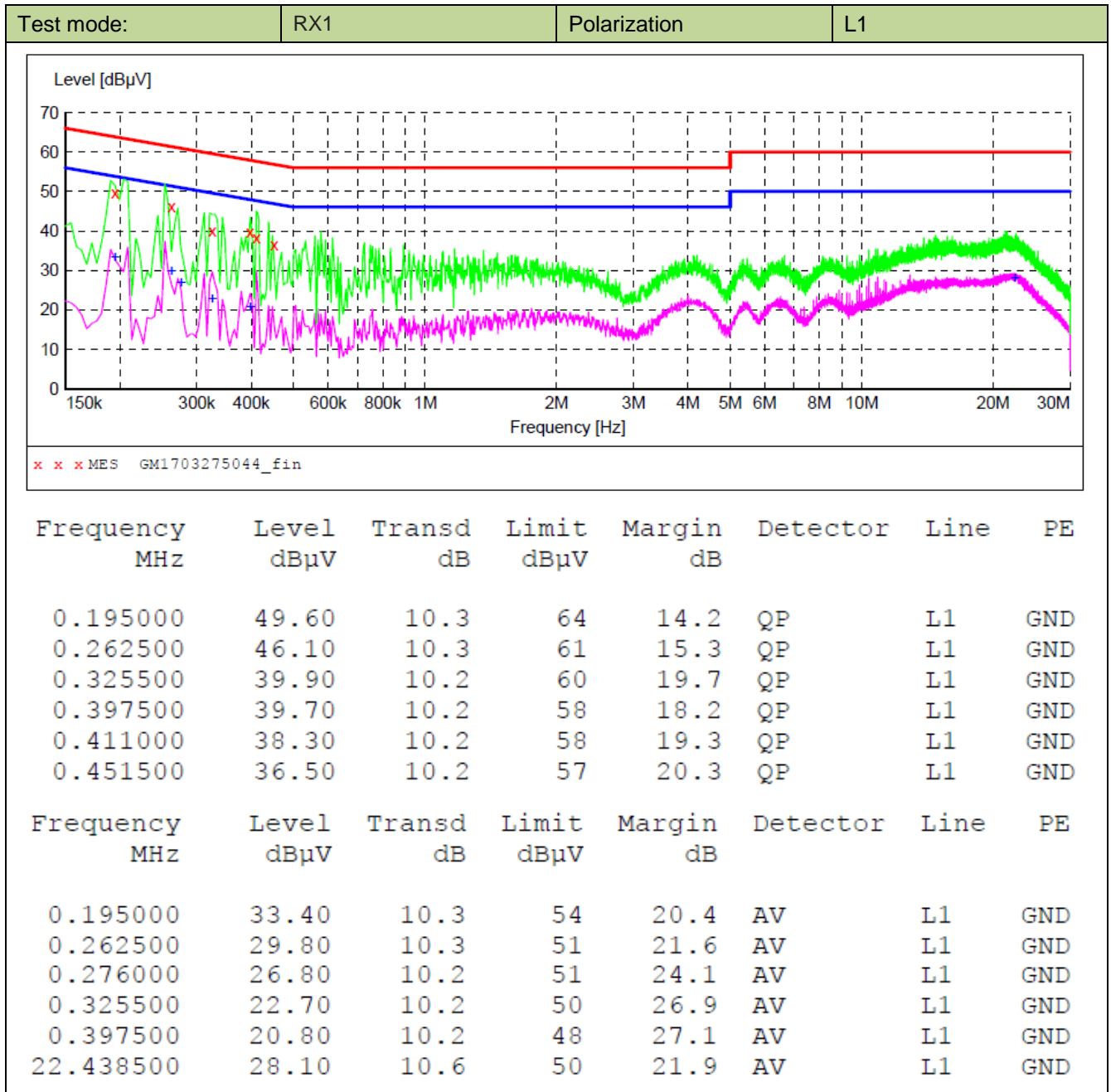

5.9. Radiated Emission

LIMIT

For unintentional device, according to § 15.109(a) except for Class A digital devices, the field strength of radiated emissions from unintentional radiators at a distance of 3 meters shall not exceed the following values:

Frequency (MHz)	Distance (Meters)	Radiated (dB μ V/m)	Radiated (μ V/m)
30-88	3	40.0	100
88-216	3	43.5	150
216-960	3	46.0	200
Above 960	3	54.0	500

For intentional device, according to § 15.209(a), the general requirement of field strength of radiated emissions from intentional radiators at a distance of 3 meters shall not exceed the above table.

TEST CONFIGURATION

(A) Radiated Emission Test Set-Up, Frequency below 1000MHz

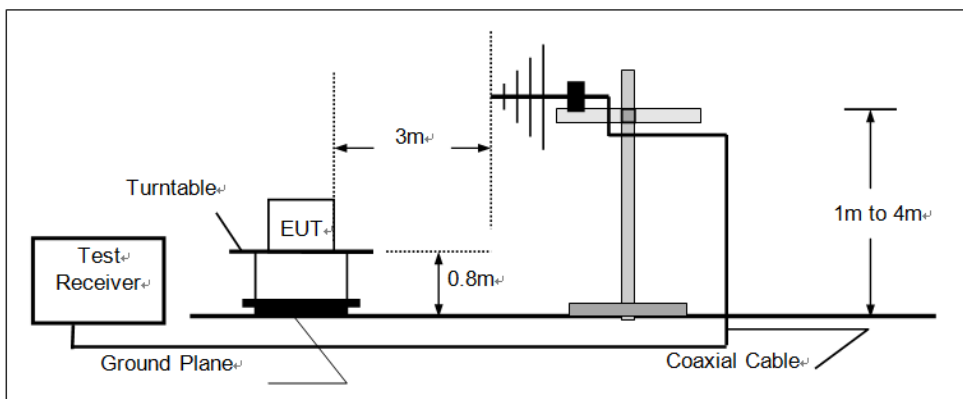

(B) Radiated Emission Test Set-Up, Frequency above 1000MHz

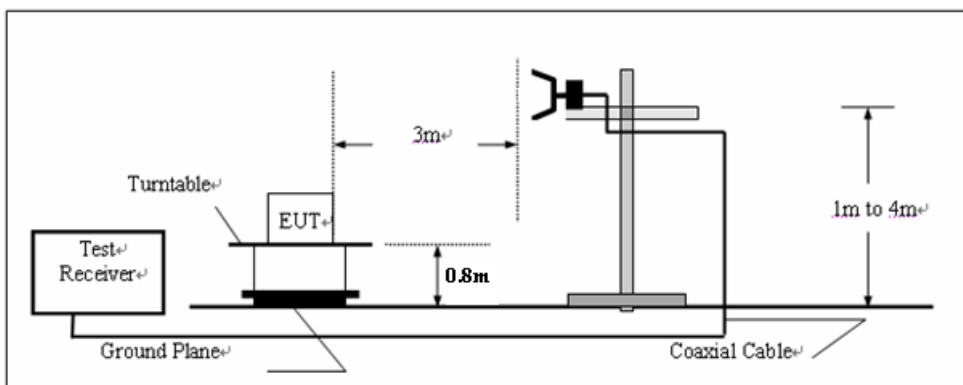

TEST PROCEDURE

- 1 The EUT was placed on a turn table which is 0.8m above ground plane.
- 2 Maximum procedure was performed by raising the receiving antenna from 1m to 4m and rotating the turn table from 0° to 360° to acquire the highest emissions from EUT
- 3 And also, each emission was to be maximized by changing the polarization of receiving antenna both horizontal and vertical.
- 4 Repeat above procedures until all frequency measurements have been completed.

TEST MODE:

Please reference to the section 2.4

TEST RESULTS

Passed **Not Applicable**

Please refer to the below test data:

Test mode:	RX1	Polarity:	Horizontal
------------	-----	-----------	------------

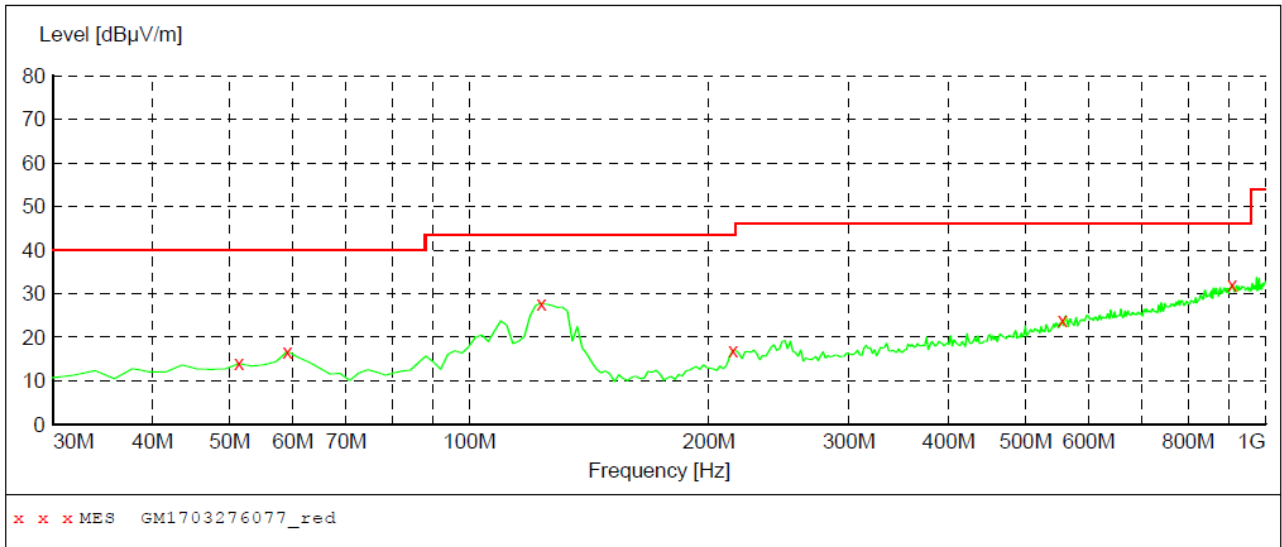

Frequency MHz	Level dBµV/m	Transd dB	Limit dBµV/m	Margin dB	Det.	Height cm	Azimuth deg	Polarization
51.340000	14.00	-16.3	40.0	26.0	QP	300.0	114.00	HORIZONTAL
59.100000	16.80	-17.1	40.0	23.2	QP	300.0	239.00	HORIZONTAL
123.120000	27.80	-18.6	43.5	15.7	QP	300.0	202.00	HORIZONTAL
214.300000	17.00	-15.5	43.5	26.5	QP	300.0	229.00	HORIZONTAL
555.740000	23.80	-6.0	46.0	22.2	QP	100.0	342.00	HORIZONTAL
908.820000	32.10	1.2	46.0	13.9	QP	300.0	239.00	HORIZONTAL

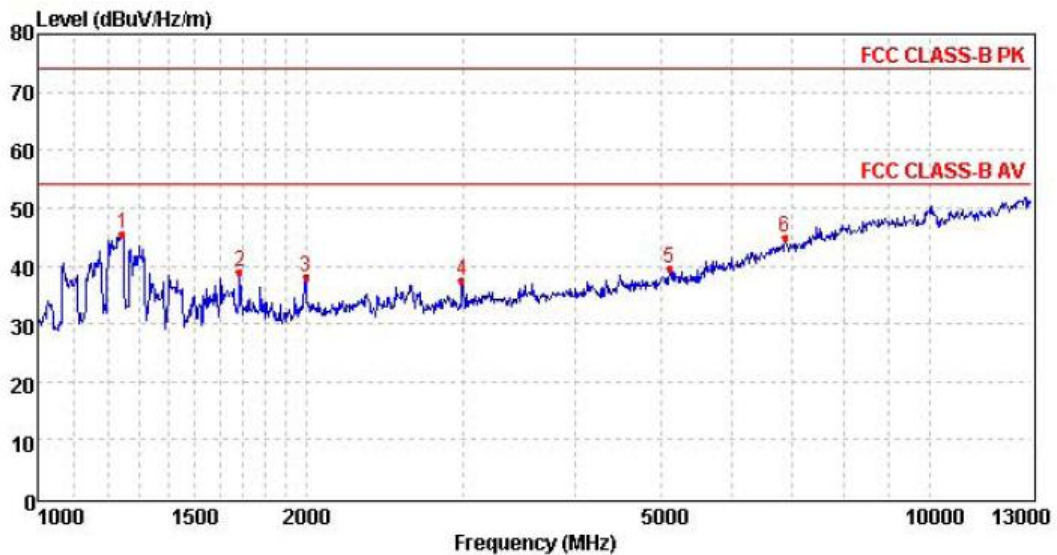

Mark	Frequency MHz	Reading dBuV/m	Antenna dB	Cable dB	Preamp dB	Level dBuV/m	Limit dBuV/m	Over limit	Remark
1	1243.61	52.92	24.47	4.73	36.55	45.57	74.00	-28.43	Peak
2	1683.18	44.73	25.26	5.73	36.89	38.83	74.00	-35.17	Peak
3	1998.78	43.10	26.10	6.27	37.30	38.17	74.00	-35.83	Peak
4	2989.88	39.67	28.49	7.47	38.24	37.39	74.00	-36.61	Peak
5	5110.55	34.55	31.45	9.76	36.29	39.47	74.00	-34.53	Peak
6	6881.54	32.37	35.63	11.70	34.91	44.79	74.00	-29.21	Peak

Test mode:	RX1	Polarity:	Vertical
------------	-----	-----------	----------

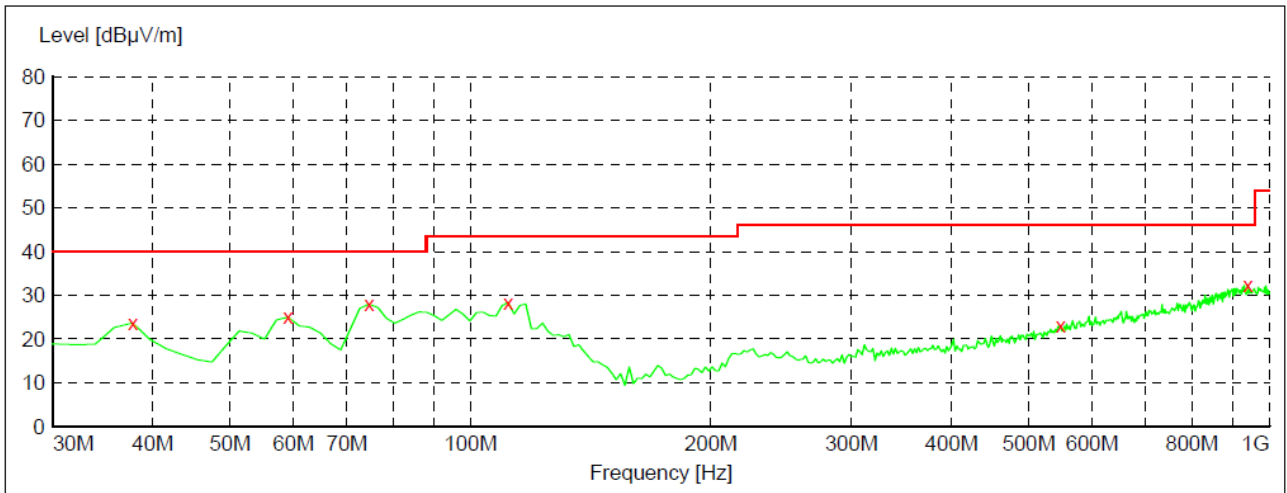

x x x MES GM1703276078_red

Frequency MHz	Level dBµV/m	Transd dB	Limit dBµV/m	Margin dB	Det.	Height cm	Azimuth deg	Polarization
37.760000	23.70	-17.3	40.0	16.3	QP	100.0	163.00	VERTICAL
59.100000	25.00	-17.1	40.0	15.0	QP	100.0	0.00	VERTICAL
74.620000	28.00	-20.0	40.0	12.0	QP	100.0	139.00	VERTICAL
111.480000	28.40	-17.9	43.5	15.1	QP	100.0	76.00	VERTICAL
547.980000	23.00	-6.3	46.0	23.0	QP	100.0	356.00	VERTICAL
939.860000	32.40	1.5	46.0	13.6	QP	100.0	163.00	VERTICAL

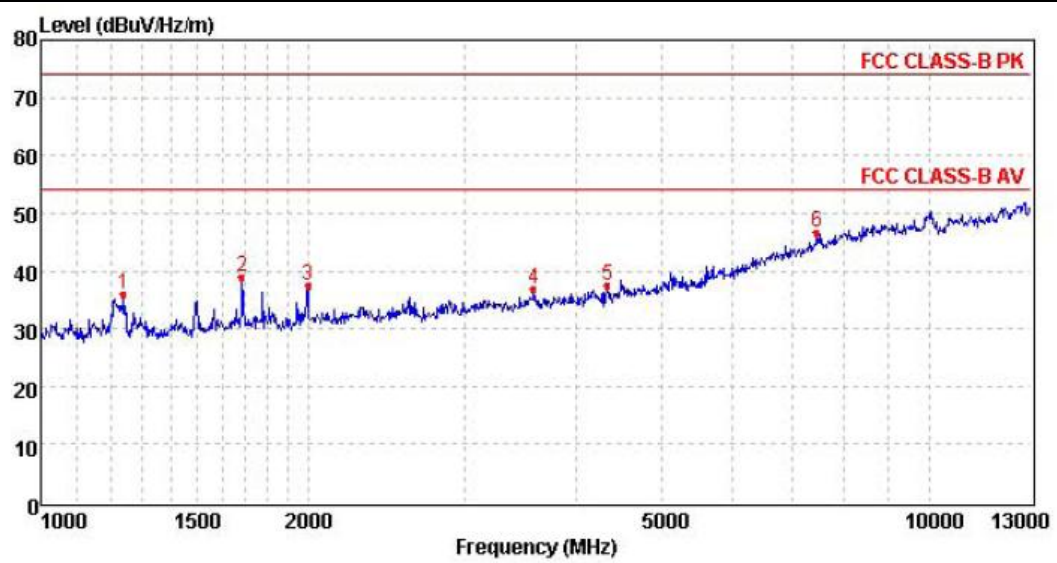

Mark	Frequency MHz	Reading dBuV/m	Antenna dB	Cable dB	Preamp dB	Level dBuV/m	Limit dBuV/m	Over limit	Remark
1	1240.43	43.48	24.47	4.73	36.55	36.13	74.00	-37.87	Peak
2	1683.18	44.73	25.26	5.73	36.89	38.83	74.00	-35.17	Peak
3	1998.78	42.34	26.10	6.27	37.30	37.41	74.00	-36.59	Peak
4	3587.10	37.95	28.85	8.25	38.29	36.76	74.00	-37.24	Peak
5	4336.86	35.61	30.48	9.07	37.59	37.57	74.00	-36.43	Peak
6	7470.19	32.99	36.18	12.30	34.88	46.59	74.00	-27.41	Peak

6. Test Setup Photos of the EUT

Transmitter Radiated Spurious Emission:

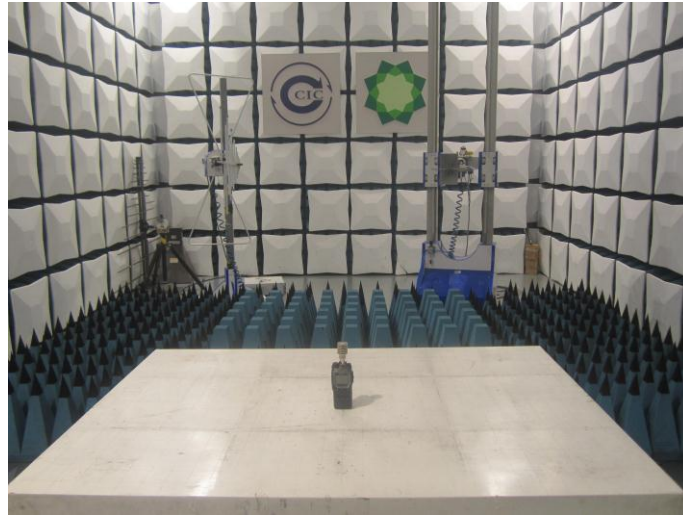

Radiated Emission:

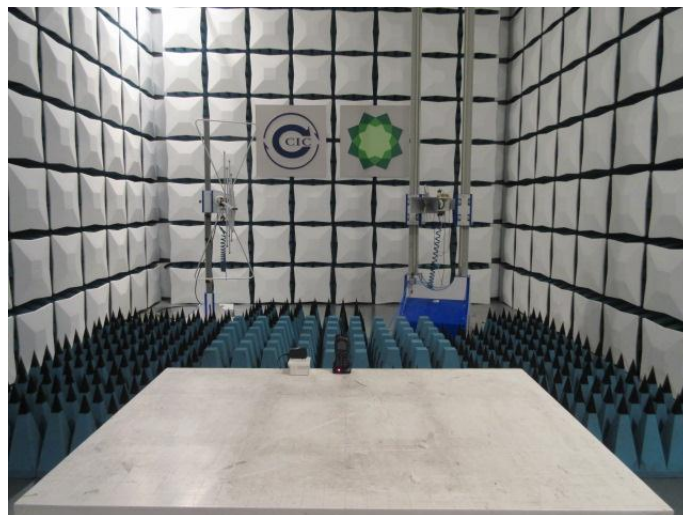
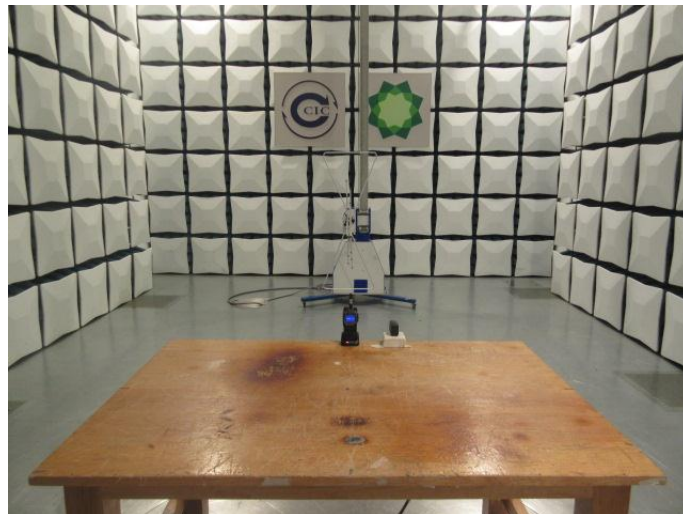

Conducted Emission:



Frequency Stability:



7. External and Internal Photos of the EUT

External photos of the EUT

TETRA&GPS ANT







Internal photos of the EUT

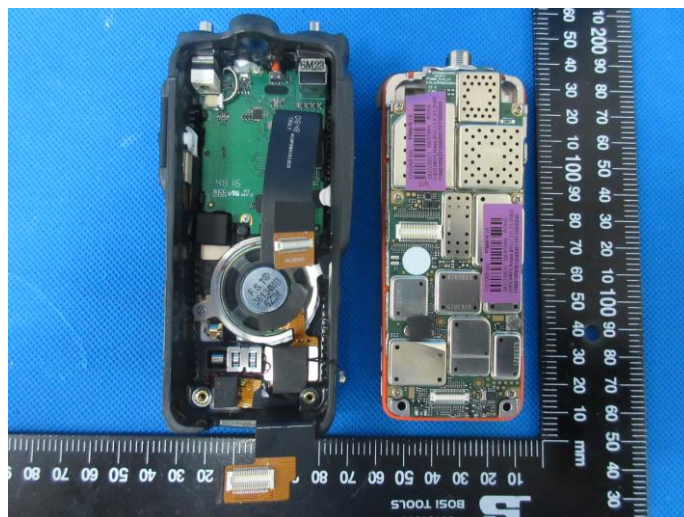

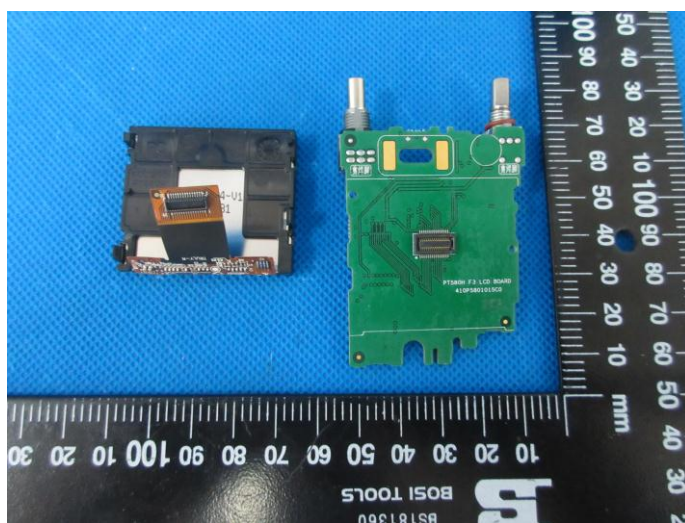
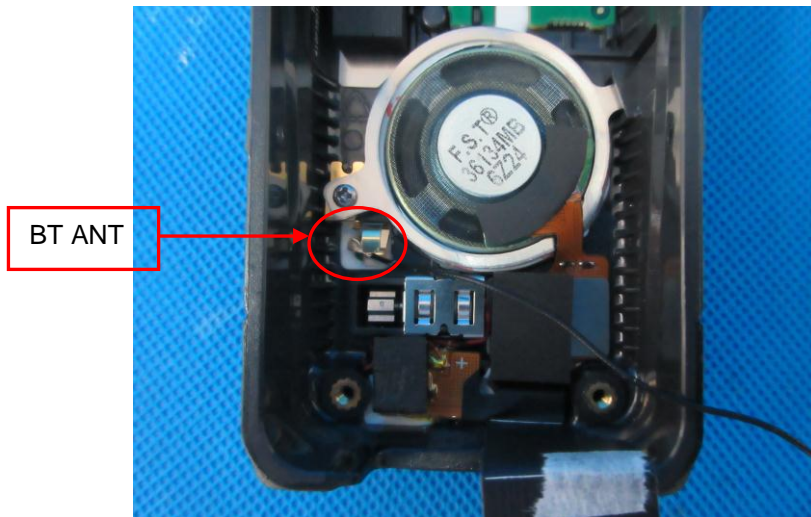

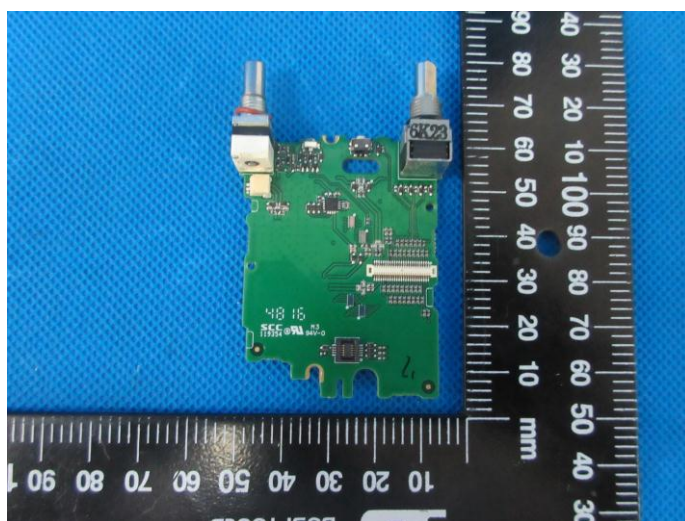
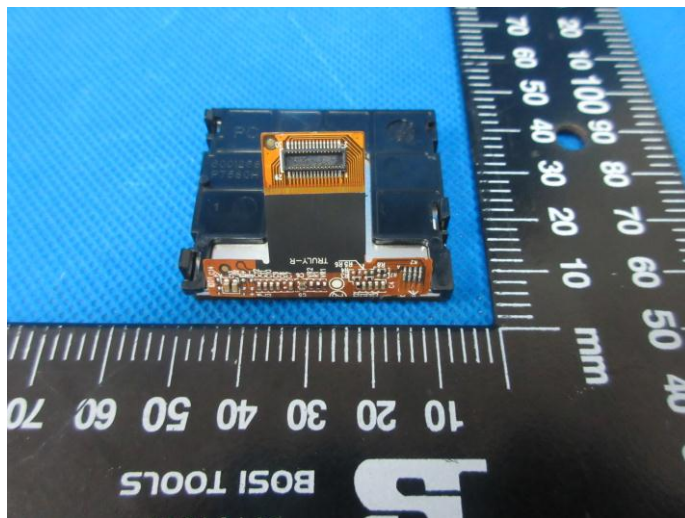
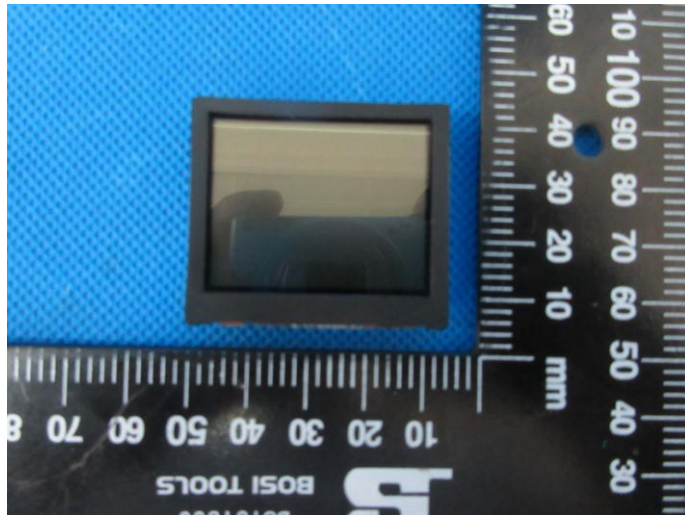

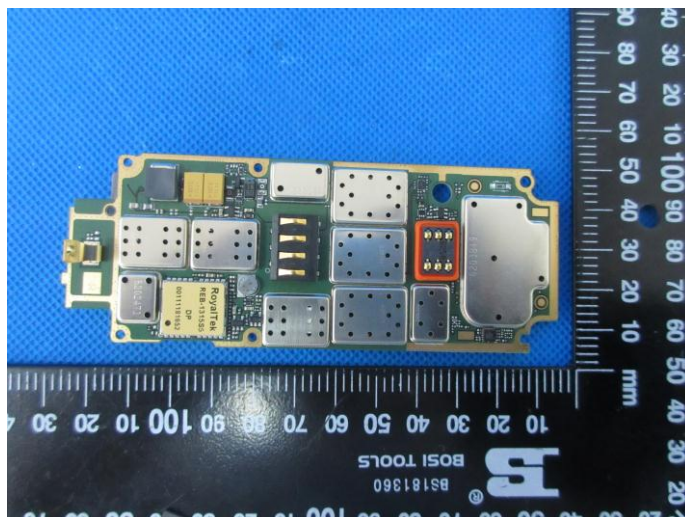
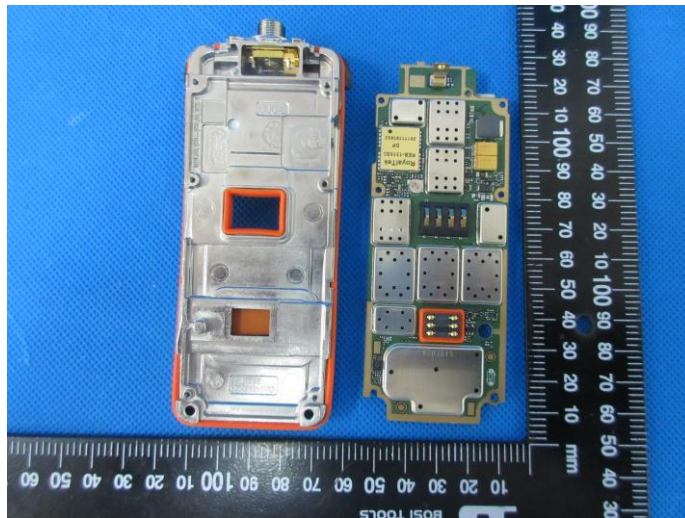
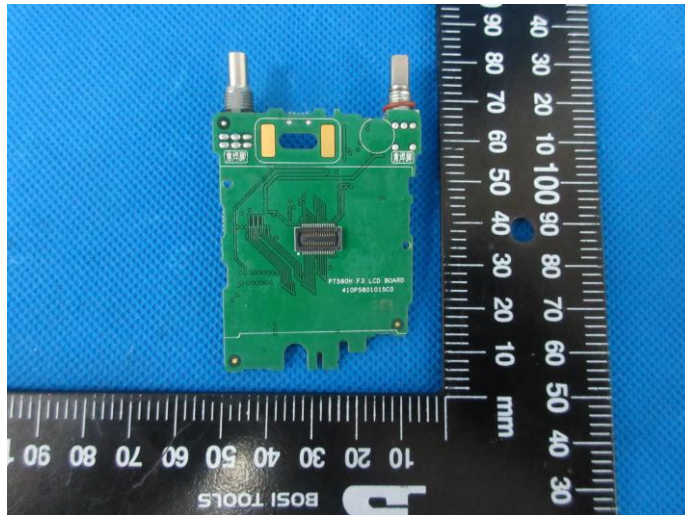

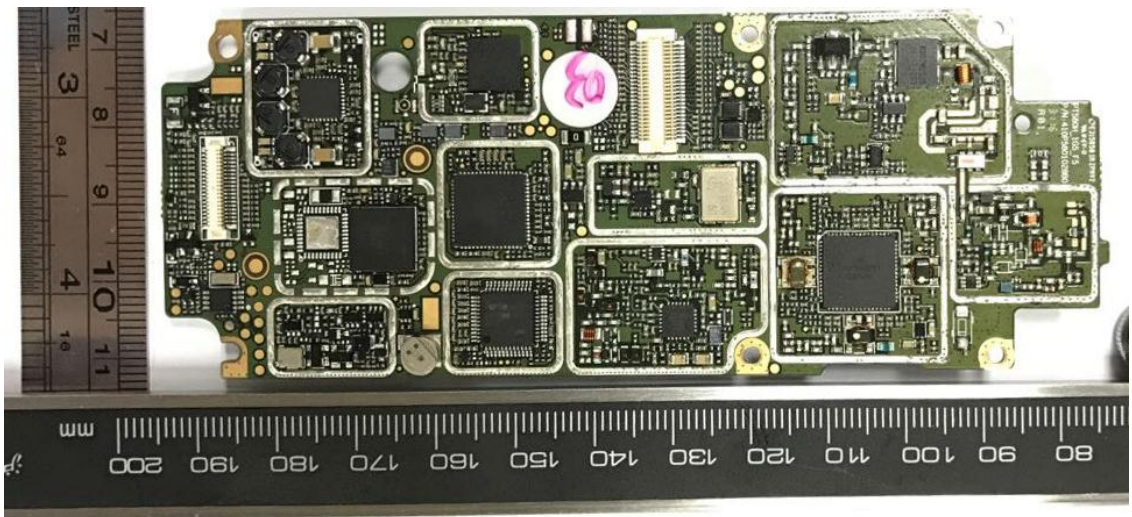
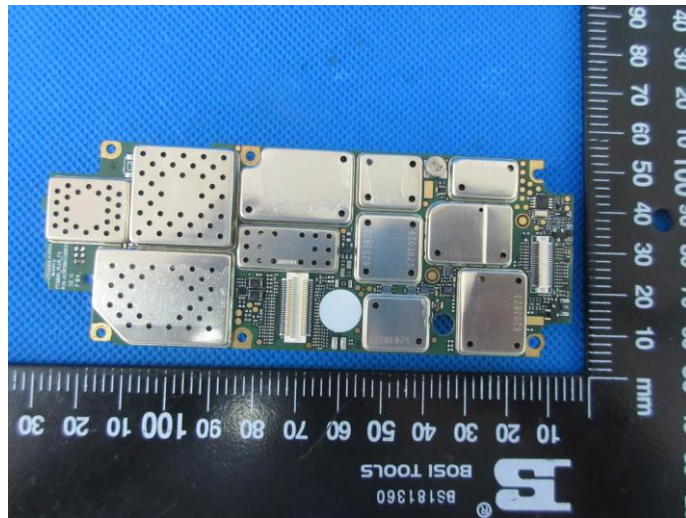
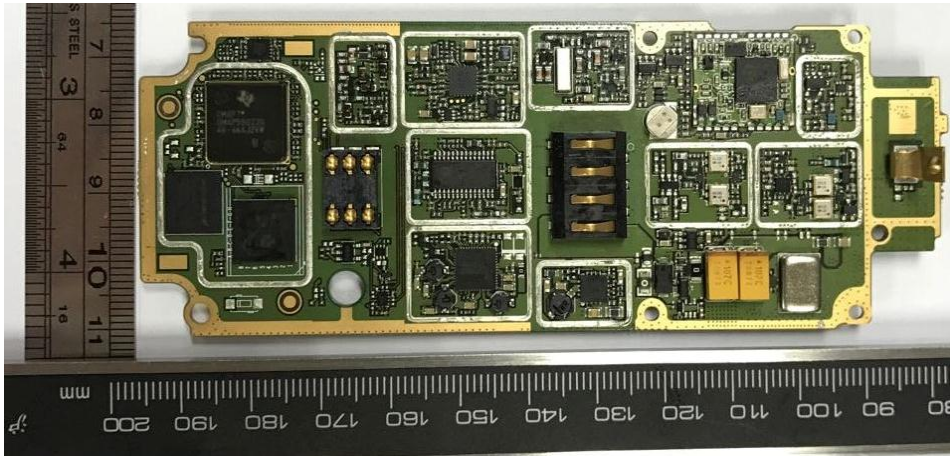

.....End of Report.....