



FCC PART 27  
FCC PART 90  
FCC PART 22H, PART 24E  
TEST REPORT

For

**Hytera Communications Corporation Limited**

Hytera Tower, Hi-Tech Industrial Park North, 9108# Beihuan Road, Nanshan District, Shenzhen,  
518057 China

**FCC ID: YAMPDC760UXB1**

<b>Report Type:</b> Original Report	<b>Product Type:</b> Multi-mode Advanced Radio
<b>Report Number:</b> RDG170313007-00D	
<b>Report Date:</b> 2017-05-24	
<b>Reviewed By:</b> Engineer	Oscar Ye 
<b>Prepared By:</b>	Bay Area Compliance Laboratories Corp. (Kunshan) No.248 Chenghu Road, Kunshan, Jiangsu province, China Tel: +86-0512-86175000 Fax: +86-0512-88934268 <a href="http://www.baclcorp.com.cn">www.baclcorp.com.cn</a>

**Note:** This test report is prepared for the customer shown above and for the device described herein. It may not be duplicated or used in part without prior written consent from Bay Area Compliance Laboratories Corp.

## TABLE OF CONTENTS

<b>GENERAL INFORMATION.....</b>	<b>3</b>
PRODUCT DESCRIPTION FOR EQUIPMENT UNDER TEST (EUT) .....	3
OBJECTIVE .....	3
RELATED SUBMITTAL(S)/GRANT(S).....	3
TEST METHODOLOGY .....	3
MEASUREMENT UNCERTAINTY.....	4
TEST FACILITY .....	4
<b>SYSTEM TEST CONFIGURATION.....</b>	<b>5</b>
DESCRIPTION OF TEST CONFIGURATION .....	5
EQUIPMENT MODIFICATIONS .....	5
SUPPORT EQUIPMENT LIST AND DETAILS .....	5
BLOCK DIAGRAM OF TEST SETUP .....	5
<b>SUMMARY OF TEST RESULTS .....</b>	<b>6</b>
<b>TEST EQUIPMENT LIST .....</b>	<b>7</b>
<b>FCC §1.1307 &amp; §2.1093 - RF EXPOSURE.....</b>	<b>8</b>
APPLICABLE STANDARD .....	8
TEST RESULT .....	8
<b>FCC §2.1047 - MODULATION CHARACTERISTIC .....</b>	<b>9</b>
<b>FCC § 2.1046, § 22.913 (A) &amp; § 24.232 (C); §27.50(A)(D)(H); §90.635 (B) - RF OUTPUT POWER .....</b>	<b>10</b>
APPLICABLE STANDARD .....	10
TEST PROCEDURE .....	10
TEST DATA .....	11
<b>FCC §2.1049, §22.917, §22.905 &amp; §24.238 &amp; §27.53 &amp; §90.209 - OCCUPIED BANDWIDTH.....</b>	<b>45</b>
APPLICABLE STANDARD .....	45
TEST PROCEDURE .....	45
TEST DATA .....	45
<b>FCC §2.1051, §22.917(A) &amp; §24.238(A); §27.53(A) (H) (M); §90.691 - SPURIOUS EMISSIONS AT ANTENNA TERMINALS .....</b>	<b>121</b>
APPLICABLE STANDARD .....	121
TEST PROCEDURE .....	121
TEST DATA .....	121
<b>FCC § 2.1053; § 22.917 (A);§ 24.238 (A); §27.53(A)(H)(M) ; §90.691 SPURIOUS RADIATED EMISSIONS</b>	<b>160</b>
APPLICABLE STANDARD .....	160
TEST PROCEDURE .....	160
TEST DATA .....	160
<b>FCC § 22.917 (A); § 24.238 (A); §27.53 (A)(H)(M) §90.691 - BAND EDGES.....</b>	<b>164</b>
APPLICABLE STANDARD .....	164
TEST PROCEDURE .....	164
TEST DATA .....	165
<b>FCC § 2.1055; § 22.355; § 24.235; §27.54; §90.213- FREQUENCY STABILITY .....</b>	<b>236</b>
APPLICABLE STANDARD .....	236
TEST PROCEDURE .....	237
TEST DATA .....	237

## GENERAL INFORMATION

---

### Product Description for Equipment under Test (EUT)

The *Hytera Communications Corporation Limited's* product, model number: *PDC760 UxB1 (FCC ID: YAMPDC760UXB1)* in this report is a *Multi-mode Advanced Radio* which was measured approximately: 24 cm (L) \* 7.0 cm (W) \* 2.5 cm (H), rated with input voltage: DC 7.4 V battery or DC 12.0V from adapter.

#### Adapter Information:

Model: S024WM1200200

Input: AC 100-240V, 50/60Hz, 600 mA

Output: DC 12.0V, 2000mA

*Notes: This series products model: PDC760 U1B1, PDC760 U2B1 and PDC760 UxB1 are identical; they have the identical schematics, only named and frequency differently. Model PDC760 UxB1 was selected for fully testing, the detailed information can be referred to the declaration which was stated and guaranteed by the applicant.*

*\* All measurement and test data in this report was gathered from production sample serial number: 170313007 (Assigned by BACL, Kunshan). The EUT supplied by the applicant was received on 2017-03-13.*

### Objective

This test report is prepared on behalf of *Hytera Communications Corporation Limited* in accordance with Part 2-Subpart J, Part 22-Subpart H and Part 24-Subpart E and Part 27 and Part 90 of the Federal Communication Commissions rules.

The objective is to determine the compliance of the EUT with FCC rules for output power, modulation characteristic, occupied bandwidth, and spurious emission at antenna terminal, spurious radiated emission, frequency stability and band edge.

### Related Submittal(s)/Grant(s)

Part 22&74&80&90 TNF, FCC Part 15.225 DXX and FCC Part 15.247 DTS/DSS submissions with FCC ID: *YAMPDC760UXB1*.

### Test Methodology

All tests and measurements indicated in this document were performed in accordance with the Code of Federal Regulations Title 47 Part 2-Subpart J as well as the following parts:

Part 22 Subpart H - Public Mobile Services

Part 24 Subpart E - Personal Communication Services

Part 27 – Miscellaneous wireless communications services

Part 90- PRIVATE LAND MOBILE RADIO SERVICES

Applicable Standards: TIA/EIA 603-D, ANSI C63.4-2014.

All emissions measurement was performed at Bay Area Compliance Laboratories Corp. (Kunshan). The radiated testing was performed at an antenna-to-EUT distance of 3 meters.

### Measurement Uncertainty

Item		Uncertainty
RF conducted test with spectrum		±0.9dB
RF Output Power with Power meter		±0.5dB
Radiated emission	30MHz~1GHz	±5.91dB
	Above 1G	±4.92dB
Occupied Bandwidth		±0.5kHz
Temperature		±1.0°C
Humidity		±6%

### Test Facility

The Test site used by Bay Area Compliance Laboratories Corp. (Kunshan) to collect test data is located on the No.248 Chenghu Road, Kunshan, Jiangsu province, China

Bay Area Compliance Laboratories Corp. (Kunshan) has been accredited to ISO/IEC 17025 by CNAS(Lab code: L9963). And accredited to ISO/IEC 17025 by A2LA(Lab code: 4323.01), the FCC Designation No. CN1185 under the KDB 974614 D01.

The Federal Communications Commission has the reports on file and is listed under FCC Registration No.: 815570. The test site has been approved by the FCC for public use and is listed in the FCC Public Access Link (PAL) database.

Bay Area Compliance Laboratories Corp. (Kunshan) was registered with ISED Canada under ISED Canada Registration Number 3062E.

## SYSTEM TEST CONFIGURATION

### Description of Test Configuration

The EUT was configured for testing according to TIA/EIA-603-D.

The final qualification test was performed with the EUT operating at normal mode.

### Equipment Modifications

No modification was made to the EUT.

### Support Equipment List and Details

Manufacturer	Description	Model	Serial Number
Rohde & Schwarz	Universal Radio Communication Tester	CMU200	110605
Rohde & Schwarz	Wideband Radio Communication Tester	CMW500	1201.002K50-116218-UY

### Block Diagram of Test Setup

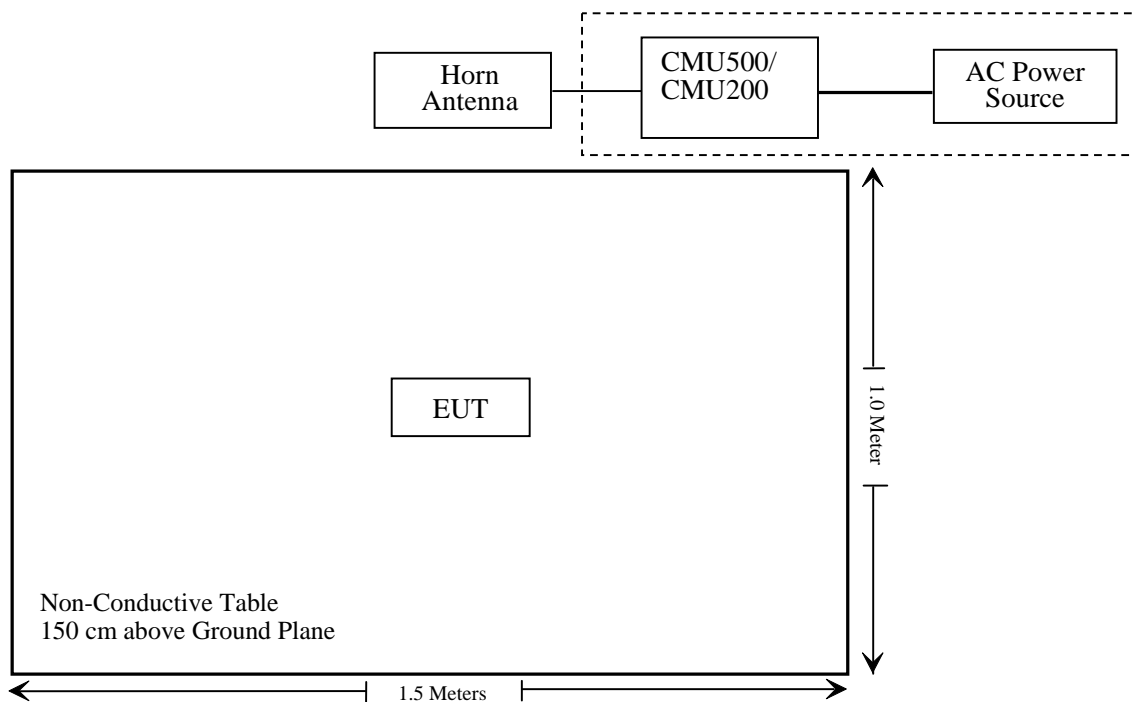

## SUMMARY OF TEST RESULTS

FCC Rules	Description of Test	Result
§1.1307, §2.1093	RF Exposure (SAR)	Compliance
§2.1046; § 22.913 (a); § 24.232 (c); §27.50(a)(d)(h); §90.635 (b)	RF Output Power	Compliance
§ 2.1047	Modulation Characteristics	Not Applicable
§ 2.1049; § 22.905; § 22.917; § 24.238; §27.53; §90.209	Occupied Bandwidth	Compliance
§ 2.1051; § 22.917 (a); § 24.238 (a); §27.53(a)(h)(m); §90.691	Spurious Emissions at Antenna Terminal	Compliance
§ 2.1053; § 22.917 (a); § 24.238 (a); §27.53(a)(h)(m); §90.691	Field Strength of Spurious Radiation	Compliance
§ 22.917 (a); § 24.238 (a); §27.53(a)(h)(m); §90.691	Band Edge	Compliance
§ 2.1055; § 22.355; § 24.235; §27.54; §90.213	Frequency stability	Compliance

**TEST EQUIPMENT LIST**

Manufacturer	Description	Model	Serial Number	Calibration Date	Calibration Due Date
<b>Radiated Emission Test</b>					
Sonoma Instrument	Amplifier	330	171377	2016-12-12	2017-12-12
Rohde & Schwarz	EMI Test Receiver	ESCI	100195	2016-11-25	2017-11-25
Sunol Sciences	Broadband Antenna	JB3	A090314-2	2016-01-09	2019-01-08
Sunol Sciences	Broadband Antenna	JB3	A090314-1	2016-01-09	2019-01-08
Narda	Pre-amplifier	AFS42-00101800	2001270	2016-09-08	2017-09-08
EMCO	Horn Antenna	3116	00084159	2016-10-18	2019-10-17
Rohde & Schwarz	Signal Analyzer	FSIQ26	100048	2016-11-25	2017-11-25
ETS	Horn Antenna	3115	6229	2016-12-12	2019-12-12
ETS	Horn Antenna	3115	9311-4159	2016-01-11	2019-01-10
R&S	Auto test Software	EMC32	V 09.10.0	NCR	NCR
haojintech	Coaxial Cable	Cable-1	001	2016-12-12	2017-12-12
haojintech	Coaxial Cable	Cable-2	002	2016-12-12	2017-12-12
haojintech	Coaxial Cable	Cable-3	003	2016-12-12	2017-12-12
MICRO-COAX	Coaxial Cable	Cable-4	004	2016-12-12	2017-12-12
MICRO-COAX	Coaxial Cable	Cable-5	005	2016-12-12	2017-12-12
MICRO-COAX	Coaxial Cable	Cable-7	007	2016-12-12	2017-12-12
HP	Signal Generator	8341B	2624A00116	2016-08-29	2017-08-29
<b>RF Conducted test</b>					
BACL	TS 8997 Cable-01	T-KS-EMC086	T-KS-EMC086	2016-12-09	2017-12-08
BACL	RF cable	KS-LAB-012	KS-LAB-012	2016-12-15	2017-12-14
Rohde & Schwarz	Signal Analyzer	FSIQ26	836131/009	2016-09-21	2017-09-21
Rohde & Schwarz	Universal Radio Communication Tester	CMU200	110605	2016-11-25	2017-11-25
R&S	Wideband Radio Communication tester	CMW500	1201.002K50-116218-UY	2016-10-08	2017-10-07
HONOVA	Power Splitter	ZFRSC-14-S+	019411452	2016-06-12	2017-06-12
WEINSCHL	10dB Attenuator	5328	N/A	2016-06-18	2017-06-18

\* **Statement of Traceability:** Bay Area Compliance Laboratories Corp. (Kunshan) attests that all calibrations have been performed in accordance to requirements that traceable to National Primary Standards and International System of Units (SI).

---

## **FCC §1.1307 & §2.1093 - RF EXPOSURE**

---

### **Applicable Standard**

FCC§1.1310 and §2.1093.

### **Test Result**

Compliance, please refer to the SAR report: RDG170313007-20A.



---

## **FCC §2.1047 - MODULATION CHARACTERISTIC**

---

According to FCC § 2.1047(d), Part 22H, 24E & Part 27 & Part 90S there are no specific requirement for digital modulation, therefore modulation characteristic is not presented.

## FCC § 2.1046, § 22.913 (a) & § 24.232 (c); §27.50(a)(d)(h); §90.635 (b) - RF OUTPUT POWER

### Applicable Standard

According to FCC §2.1046 and §22.913 (a), the ERP of mobile transmitters and auxiliary test transmitters must not exceed 7 watts.

According to FCC §2.1046 and §24.232 (C), mobile and portable stations are limited to 2 watts EIRP and the equipment must employ a means for limiting power to the minimum necessary for successful communications.

According to §27.50(a), Mobile and portable stations. (i) For mobile and portable stations transmitting in the 2305-2315 MHz band or the 2350-2360 MHz band, the average EIRP must not exceed 50 milliwatts within any 1 megahertz of authorized bandwidth, except that for mobile and portable stations compliant with 3GPP LTE standards or another advanced mobile broadband protocol that avoids concentrating energy at the edge of the operating band the average EIRP must not exceed 250 milliwatts within any 5 megahertz of authorized bandwidth but may exceed 50 milliwatts within any 1 megahertz of authorized bandwidth. For mobile and portable stations using time division duplexing (TDD) technology, the duty cycle must not exceed 38 percent in the 2305-2315 MHz and 2350-2360 MHz bands. Mobile and portable stations using FDD technology are restricted to transmitting in the 2305-2315 MHz band. Power averaging shall not include intervals in which the transmitter is off.

According to §27.50(d), the maximum EIRP must not exceed 1Watts (30dBm) for 1710-1755MHz. The peak-to-average power ratio (PAPR) of the transmitter output power must not exceed 13 dB.

According to §27.50(h), Mobile and other user stations. Mobile stations are limited to 2.0 watts EIRP. All user stations are limited to 2.0 watts transmitter output power.

According to §90.635(b) The maximum output power of the transmitter for mobile stations is 100 watts (20 dBw).

### Test Procedure

#### *Conducted method:*

The RF output of the transmitter was connected to the CMU200 through sufficient attenuation.

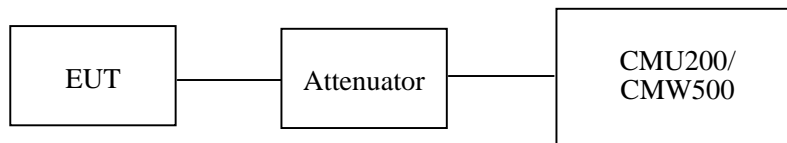

#### *Radiated method:*

TIA 603-D section 2.2.17

**Test Data****Environmental Conditions**

<b>Temperature:</b>	24 °C
<b>Relative Humidity:</b>	52 %
<b>ATM Pressure:</b>	101.0 kPa

The testing was performed by Nefertari Xu on 2017-03-16.

**Conducted Power****Cellular Band (Part 22H)**

Mode	Channel	Frequency (MHz)	Average Output Power (dBm)	Limit (dBm)
GSM	128	824.2	32.04	38.45
	190	836.6	32.09	38.45
	251	848.8	32.15	38.45

Mode	Channel	Frequency (MHz)	Average Output Power (dBm)				Limit (dBm)
			1 slot	2 slots	3 slots	4 slots	
GPRS	128	824.2	32.11	29.83	27.95	26.56	38.45
	190	836.6	32.16	29.77	27.94	26.50	38.45
	251	848.8	32.22	29.83	27.86	26.46	38.45

Mode	Channel	Frequency (MHz)	Average Output Power (dBm)				Limit (dBm)
			1 slot	2 slots	3 slots	4 slots	
EGPRS	128	824.2	25.58	24.45	22.71	21.53	38.45
	190	836.6	25.48	24.35	22.59	21.46	38.45
	251	848.8	25.45	24.35	22.55	21.47	38.45

Mode	Channel	Frequency (MHz)	Average Output Power (dBm)	Limit (dBm)
CDMA RC3 SO55(LOOKBACK)	1013	824.70	21.98	38.45
	384	836.52	22.03	38.45
	777	848.31	22.33	38.45

Mode	Channel	Frequency (MHz)	Average Output Power (dBm)	Limit (dBm)
CDMA (EV-DO,FTAP Rate:307.2Kpbs 2 Slot.QPSK RTAP Rate: 153.6 Kpbs)	1013	824.70	20.46	38.45
	384	836.52	20.95	38.45
	777	848.31	20.33	38.45

**PCS Band (Part 24E)**

Mode	Channel	Frequency (MHz)	Average Output Power (dBm)	Limit (dBm)
GSM	512	1850.2	29.38	33
	661	1880.0	29.62	33
	810	1909.8	29.11	33

Mode	Channel	Frequency (MHz)	Average Output Power (dBm)				Limit (dBm)
			1 slot	2 slots	3 slots	4 slots	
GPRS	512	1850.2	29.38	28.57	26.36	24.70	33
	661	1880.0	29.59	28.48	26.48	25.02	33
	810	1909.8	29.10	28.21	26.74	25.06	33

Mode	Channel	Frequency (MHz)	Average Output Power (dBm)				Limit (dBm)
			1 slot	2 slots	3 slots	4 slots	
EGPRS	512	1850.2	25.33	24.05	22.90	21.51	33
	661	1880.0	25.31	24.04	22.90	21.68	33
	810	1909.8	25.33	24.09	22.94	21.74	33

**Peak-to-average ratio (PAR)**

**Cellular Band**

Mode	Channel	PAR (dB)	Limit (dB)
GSM	Low	0.53	13
	Middle	0.61	13
	High	0.58	13

Mode	Channel	PAR (dB)	Limit (dB)
EGPRS	Low	0.32	13
	Middle	0.36	13
	High	0.37	13

Mode	Channel	PAR (dB)	Limit (dB)
CDMA	Low	1.36	13
	Middle	1.30	13
	High	1.44	13

Mode	Channel	PAR (dB)	Limit (dB)
CDMA (EV-DO)	Low	1.20	13
	Middle	1.16	13
	High	1.19	13

**PCS Band**

Mode	Channel	PAR (dB)	Limit (dB)
GSM	Low	0.42	13
	Middle	0.46	13
	High	0.48	13

Mode	Channel	PAR (dB)	Limit (dB)
EGPRS	Low	0.47	13
	Middle	0.43	13
	High	0.49	13

**Radiated Power**

**GSM Mode:**

Frequency (MHz)	Receiver Reading (dBµV)	Turntable Angle Degree	Rx Antenna		Substituted			Absolute Level (dBm)	FCC Part 22H/24E	
			Height (m)	Polar (H/V)	Level (dBm)	Cable loss (dB)	Antenna Gain (dB)		Limit (dBm)	Margin (dB)
ERP for Cellular Band (Part 22H), Middle Channel										
836.6	97.04	282	1	H	26.8	0.26	4.75	31.29	38.45	7.16
836.6	101.56	128	2.4	V	27.3	0.26	4.75	31.79	38.45	6.66
EIRP for PCS Band (Part 24E), Middle Channel										
1880.0	82.39	304	1.9	H	20.9	0.45	8.84	29.29	33	3.71
1880.0	79.92	253	2.1	V	16.2	0.45	8.84	24.59	33	8.41

**EGRPS Mode:**

Frequency (MHz)	Receiver Reading (dBµV)	Turntable Angle Degree	Rx Antenna		Substituted			Absolute Level (dBm)	FCC Part 22H/24E	
			Height (m)	Polar (H/V)	Level (dBm)	Cable loss (dB)	Antenna Gain (dB)		Limit (dBm)	Margin (dB)
ERP for Cellular Band (Part 22H), Middle Channel										
836.6	90.24	282	1	H	20.0	0.26	4.75	24.49	38.45	13.96
836.6	94.66	128	2.4	V	20.4	0.26	4.75	24.89	38.45	13.56
EIRP for PCS Band (Part 24E), Middle Channel										
1880	77.49	304	1.9	H	16.0	0.45	8.84	24.39	33	8.61
1880	74.82	253	2.1	V	11.1	0.45	8.84	19.49	33	13.51

**CDMA Mode:**

Frequency (MHz)	Receiver Reading (dBµV)	Turntable Angle Degree	Rx Antenna		Substituted			Absolute Level (dBm)	Limit (dBm)	Margin (dB)
			Height (m)	Polar (H/V)	Level (dBm)	Cable loss (dB)	Antenna Gain (dB)			
ERP for CDMA										
848.31	84.03	34	1.9	H	13.8	0.26	4.75	18.29	38.45	20.16
848.31	86.85	120	1.3	V	12.6	0.26	4.75	17.09	38.45	21.36
ERP for CDMA (EV-DO)										
836.52	83.84	22	1.2	H	13.6	0.26	4.75	18.09	38.45	20.36
836.52	86.56	96	2.0	V	12.3	0.26	4.75	16.79	38.45	21.66

**Note:**

All above data were tested with no amplifier.

Absolute Level = SG Level - Cable loss + Antenna Gain

Margin = Limit- Absolute Level

**LTE Band 2**

**Maximum Output Power**

Bandwidth (MHz)	Modulation	RB size/RB Offset	Low Channel (dBm)	Middle Channel (dBm)	High Channel (dBm)
1.4	QPSK	RB Size=1, RB Offset=0	23.61	23.54	23.67
		RB Size=1, RB Offset=2	23.70	23.64	23.58
		RB Size=1, RB Offset=5	23.53	23.4	23.37
		RB Size=3, RB Offset=0	23.41	23.35	23.39
		RB Size=3, RB Offset=1	23.48	23.48	23.44
		RB Size=3, RB Offset=2	23.55	23.38	23.44
		RB Size=6, RB Offset=0	22.50	22.45	22.47
	16QAM	RB Size=1, RB Offset=0	23.00	23.01	23.09
		RB Size=1, RB Offset=2	23.12	23.09	22.99
		RB Size=1, RB Offset=5	23.94	22.97	22.87
		RB Size=3, RB Offset=0	22.92	22.96	22.97
		RB Size=3, RB Offset=1	22.89	22.89	22.95
		RB Size=3, RB Offset=2	22.97	22.95	23.04
		RB Size=6, RB Offset=0	21.83	21.91	21.81
3.0	QPSK	RB Size=1, RB Offset=0	23.60	23.44	23.53
		RB Size=1, RB Offset=7	23.34	23.28	23.37
		RB Size=1, RB Offset=14	23.28	23.21	23.18
		RB Size=8, RB Offset=0	22.60	22.45	22.46
		RB Size=8, RB Offset=4	22.43	22.40	22.36
		RB Size=8, RB Offset=7	22.46	22.41	22.35
		RB Size=15, RB Offset=0	22.50	22.43	22.43
	16QAM	RB Size=1, RB Offset=0	21.80	21.72	21.73
		RB Size=1, RB Offset=7	21.86	21.79	21.84
		RB Size=1, RB Offset=14	21.58	21.54	21.47
		RB Size=8, RB Offset=0	22.01	21.95	21.88
		RB Size=8, RB Offset=4	22.06	21.93	21.85
		RB Size=8, RB Offset=7	21.98	21.94	21.85
		RB Size=15, RB Offset=0	21.03	21.01	21.05

Bandwidth (MHz)	Modulation	RB size/RB Offset	Low Channel (dBm)	Middle Channel (dBm)	High Channel (dBm)
5.0	QPSK	RB Size=1, RB Offset=0	23.24	23.23	23.36
		RB Size=1, RB Offset=12	23.65	23.57	23.54
		RB Size=1, RB Offset=24	23.58	23.55	23.54
		RB Size=12, RB Offset=0	22.52	22.52	22.53
		RB Size=12, RB Offset=6	22.40	22.41	22.46
		RB Size=12, RB Offset=11	22.52	22.40	22.4
		RB Size=25, RB Offset=0	22.04	21.98	21.98
	16QAM	RB Size=1, RB Offset=0	21.89	21.86	21.86
		RB Size=1, RB Offset=12	22.47	22.30	22.28
		RB Size=1, RB Offset=24	21.75	21.63	21.69
		RB Size=12, RB Offset=0	21.19	21.04	21.11
		RB Size=12, RB Offset=6	21.16	21.12	21.05
		RB Size=12, RB Offset=11	21.18	21.07	21.04
		RB Size=25, RB Offset=0	20.91	20.75	20.69
10.0	QPSK	RB Size=1, RB Offset=0	23.45	23.29	23.3
		RB Size=1, RB Offset=24	23.28	23.16	23.14
		RB Size=1, RB Offset=49	23.59	23.41	23.49
		RB Size=25, RB Offset=0	22.58	22.42	22.43
		RB Size=25, RB Offset=12	22.59	22.50	22.45
		RB Size=25, RB Offset=24	22.46	22.46	22.43
		RB Size=50, RB Offset=0	22.44	22.45	22.46
	16QAM	RB Size=1, RB Offset=0	22.35	22.24	22.33
		RB Size=1, RB Offset=24	23.02	22.95	23.03
		RB Size=1, RB Offset=49	22.27	22.29	22.32
		RB Size=25, RB Offset=0	21.48	21.33	21.28
		RB Size=25, RB Offset=12	21.24	21.26	21.32
		RB Size=25, RB Offset=24	21.44	21.28	21.32
		RB Size=50, RB Offset=0	21.45	21.37	21.28



Bandwidth (MHz)	Modulation	RB size/RB Offset	Low Channel (dBm)	Middle Channel (dBm)	High Channel (dBm)
15.0	QPSK	RB Size=1, RB Offset=0	22.81	22.80	22.87
		RB Size=1, RB Offset=37	23.55	23.39	23.42
		RB Size=1, RB Offset=74	23.68	23.56	23.53
		RB Size=36, RB Offset=0	22.29	22.27	22.22
		RB Size=36, RB Offset=18	22.53	22.44	22.4
		RB Size=36, RB Offset=37	22.52	22.38	22.32
		RB Size=75, RB Offset=0	22.37	22.37	22.42
	16QAM	RB Size=1, RB Offset=0	22.26	22.18	22.11
		RB Size=1, RB Offset=37	23.13	23.01	22.97
		RB Size=1, RB Offset=74	22.23	22.14	22.15
		RB Size=36, RB Offset=0	20.74	20.68	20.72
		RB Size=36, RB Offset=18	20.93	20.78	20.87
		RB Size=36, RB Offset=37	20.98	20.85	20.78
		RB Size=75, RB Offset=0	20.96	20.82	20.79
20.0	QPSK	RB Size=1, RB Offset=0	23.47	23.40	23.58
		RB Size=1, RB Offset=49	23.84	23.68	23.63
		RB Size=1, RB Offset=99	23.34	23.29	23.32
		RB Size=50, RB Offset=0	22.37	22.37	22.42
		RB Size=50, RB Offset=24	22.47	22.34	22.35
		RB Size=50, RB Offset=49	22.52	22.42	22.49
		RB Size=100, RB Offset=0	22.45	22.30	22.31
	16QAM	RB Size=1, RB Offset=0	21.20	21.19	21.27
		RB Size=1, RB Offset=49	21.32	21.25	21.34
		RB Size=1, RB Offset=99	21.63	21.61	21.65
		RB Size=50, RB Offset=0	20.81	20.79	20.83
		RB Size=50, RB Offset=24	21.13	20.98	20.91
		RB Size=50, RB Offset=49	20.75	20.73	20.75
		RB Size=100, RB Offset=0	20.87	20.80	20.87

**Peak-to-average ratio (PAR)**

Modulation	Middle Channel (dB)	PAR Limit (dB)	Result
16QAM (1RB Size)	4.46	13	Pass
16QAM (100%RB Size)	4.47	13	Pass

**QPSK:**

Frequency (MHz)	Receiver Reading (dBµV)	Turn table Angle Degree	Rx Antenna		Substituted			Absolute Level (dBm)	Limit (dBm)
			Height (m)	Polar (H/V)	Level (dBm)	Cable Loss (dB)	Antenna Gain (dB)		
Middle Channel									
1.4 MHz Bandwidth									
1880.00	76.29	321	2.3	H	14.8	0.45	8.84	23.19	33
1880.00	72.72	237	1.3	V	9.0	0.45	8.84	17.39	33
3 MHz Bandwidth									
1880.00	73.59	162	1.4	H	12.1	0.45	8.84	20.49	33
1880.00	70.67	303	1.3	V	6.9	0.45	8.84	15.29	33
5 MHz Bandwidth									
1880.00	73.69	250	2.0	H	12.2	0.45	8.84	20.59	33
1880.00	74.12	316	1.7	V	10.4	0.45	8.84	18.79	33
10 MHz Bandwidth									
1880.00	71.29	72	1.6	H	9.8	0.45	8.84	18.19	33
1880.00	73.32	11	1.4	V	9.6	0.45	8.84	17.99	33
15 MHz Bandwidth									
1880.00	72.59	276	2.5	H	11.1	0.45	8.84	19.49	33
1880.00	72.32	135	2.1	V	8.6	0.45	8.84	16.99	33
20 MHz Bandwidth									
1880.00	71.79	274	1.3	H	10.3	0.45	8.84	18.69	33
1880.00	72.32	269	1.4	V	8.6	0.45	8.84	16.99	33

**16QAM:**

Frequency (MHz)	Receiver Reading (dBμV)	Turn table Angle Degree	Rx Antenna		Substituted			Absolute Level (dBm)	Limit (dBm)
			Height (m)	Polar (H/V)	Level (dBm)	Cable Loss (dB)	Antenna Gain (dB)		
Middle Channel									
1.4 MHz Bandwidth									
1880.00	75.40	321	2.3	H	13.9	0.45	8.84	22.29	33
1880.00	73.82	52	1.3	V	10.1	0.45	8.84	18.49	33
3 MHz Bandwidth									
1880.00	73.39	242	2.4	H	11.9	0.45	8.84	20.29	33
1880.00	73.82	288	1.8	V	10.1	0.45	8.84	18.49	33
5 MHz Bandwidth									
1880.00	72.79	195	1.2	H	11.3	0.45	8.84	19.69	33
1880.00	74.22	297	2.2	V	10.5	0.45	8.84	18.89	33
10 MHz Bandwidth									
1880.00	72.29	185	1.8	H	10.8	0.45	8.84	19.19	33
1880.00	74.22	72	2.3	V	10.5	0.45	8.84	18.89	33
15 MHz Bandwidth									
1880.00	72.19	336	2.4	H	10.7	0.45	8.84	19.10	33
1880.00	73.52	282	2.4	V	9.8	0.45	8.84	18.20	33
20 MHz Bandwidth									
1880.00	71.29	215	1.9	H	9.8	0.45	8.84	18.19	33
1880.00	73.12	63	2.0	V	9.4	0.45	8.84	17.79	33

**LTE Band 4:**

Maximum Output Power

Bandwidth (MHz)	Modulation	RB size/RB Offset	Low Channel (dBm)	Middle Channel (dBm)	High Channel (dBm)
1.4	QPSK	RB Size=1, RB Offset=0	23.20	23.09	23.11
		RB Size=1, RB Offset=2	23.07	22.99	22.91
		RB Size=1, RB Offset=5	23.00	22.98	22.98
		RB Size=3, RB Offset=0	22.94	22.88	22.9
		RB Size=3, RB Offset=1	23.06	22.91	22.84
		RB Size=3, RB Offset=2	23.89	23.95	23.97
		RB Size=6, RB Offset=0	22.09	21.91	21.88
	16QAM	RB Size=1, RB Offset=0	22.29	22.30	22.33
		RB Size=1, RB Offset=2	22.33	22.26	22.18
		RB Size=1, RB Offset=5	22.09	22.04	22.13
		RB Size=3, RB Offset=0	22.29	22.14	22.17
		RB Size=3, RB Offset=1	22.42	22.25	22.28
		RB Size=3, RB Offset=2	22.16	22.13	22.06
		RB Size=6, RB Offset=0	21.02	21.02	21.08
3.0	QPSK	RB Size=1, RB Offset=0	22.89	22.91	22.93
		RB Size=1, RB Offset=7	23.00	22.92	22.97
		RB Size=1, RB Offset=14	23.03	22.88	22.83
		RB Size=8, RB Offset=0	22.17	22.07	22.04
		RB Size=8, RB Offset=4	22.07	21.92	21.85
		RB Size=8, RB Offset=7	22.07	21.98	21.92
		RB Size=15, RB Offset=0	22.08	22.03	22.07
	16QAM	RB Size=1, RB Offset=0	21.85	21.83	21.81
		RB Size=1, RB Offset=7	21.89	21.72	21.69
		RB Size=1, RB Offset=14	21.72	21.60	21.65
		RB Size=8, RB Offset=0	21.41	21.25	21.19
		RB Size=8, RB Offset=4	21.12	20.99	20.98
		RB Size=8, RB Offset=7	21.03	20.96	20.88
		RB Size=15, RB Offset=0	20.94	20.83	20.8

Bandwidth (MHz)	Modulation	RB size/RB Offset	Low Channel (dBm)	Middle Channel (dBm)	High Channel (dBm)
5.0	QPSK	RB Size=1, RB Offset=0	22.88	22.80	22.93
		RB Size=1, RB Offset=12	22.75	22.69	22.68
		RB Size=1, RB Offset=24	22.80	22.76	22.78
		RB Size=12, RB Offset=0	22.15	21.99	22.03
		RB Size=12, RB Offset=6	22.09	22.05	22.08
		RB Size=12, RB Offset=11	22.09	21.92	21.82
		RB Size=25, RB Offset=0	22.12	22.01	22.06
	16QAM	RB Size=1, RB Offset=0	21.63	21.65	21.66
		RB Size=1, RB Offset=12	21.90	21.87	21.96
		RB Size=1, RB Offset=24	21.42	21.52	21.55
		RB Size=12, RB Offset=0	21.04	21.02	21.07
		RB Size=12, RB Offset=6	20.97	21.05	21.09
		RB Size=12, RB Offset=11	21.00	20.95	21.08
		RB Size=25, RB Offset=0	20.89	20.87	21.02
10.0	QPSK	RB Size=1, RB Offset=0	22.34	22.25	22.35
		RB Size=1, RB Offset=24	22.37	22.47	22.60
		RB Size=1, RB Offset=49	21.87	21.90	21.93
		RB Size=25, RB Offset=0	21.26	21.19	21.31
		RB Size=25, RB Offset=12	21.31	21.38	21.47
		RB Size=25, RB Offset=24	21.46	21.40	21.38
		RB Size=50, RB Offset=0	21.29	21.38	21.44
	16QAM	RB Size=1, RB Offset=0	23.5	23.42	23.41
		RB Size=1, RB Offset=24	23.67	23.65	23.72
		RB Size=1, RB Offset=49	23.45	23.49	23.64
		RB Size=25, RB Offset=0	22.3	22.38	22.42
		RB Size=25, RB Offset=12	22.29	22.37	22.47
		RB Size=25, RB Offset=24	22.3	22.38	22.52
		RB Size=50, RB Offset=0	22.31	22.34	22.36

Bandwidth (MHz)	Modulation	RB size/RB Offset	Low Channel (dBm)	Middle Channel (dBm)	High Channel (dBm)
15.0	QPSK	RB Size=1, RB Offset=0	23.14	23.02	23.12
		RB Size=1, RB Offset=37	22.89	22.85	22.81
		RB Size=1, RB Offset=74	23.25	23.18	23.25
		RB Size=36, RB Offset=0	22.08	21.99	22.07
		RB Size=36, RB Offset=18	22.00	21.99	22.05
		RB Size=36, RB Offset=37	22.19	22.06	22.09
		RB Size=75, RB Offset=0	21.97	21.96	22.04
	16QAM	RB Size=1, RB Offset=0	21.66	21.63	21.66
		RB Size=1, RB Offset=37	21.87	21.73	21.74
		RB Size=1, RB Offset=74	21.54	21.47	21.48
		RB Size=36, RB Offset=0	20.97	20.92	20.9
		RB Size=36, RB Offset=18	20.87	20.87	20.78
		RB Size=36, RB Offset=37	20.87	20.84	20.74
		RB Size=75, RB Offset=0	20.89	20.89	20.98
20.0	QPSK	RB Size=1, RB Offset=0	21.89	21.82	21.93
		RB Size=1, RB Offset=49	23.07	22.94	22.96
		RB Size=1, RB Offset=99	22.89	22.90	22.89
		RB Size=50, RB Offset=0	22.01	21.95	22.02
		RB Size=50, RB Offset=24	22.12	21.94	21.91
		RB Size=50, RB Offset=49	22.13	22.08	22.06
		RB Size=100, RB Offset=0	22.00	21.97	22.01
	16QAM	RB Size=1, RB Offset=0	21.36	21.25	21.27
		RB Size=1, RB Offset=49	21.48	21.38	21.36
		RB Size=1, RB Offset=99	21.49	21.32	21.35
		RB Size=50, RB Offset=0	21.10	21.11	21.09
		RB Size=50, RB Offset=24	21.02	20.88	20.96
		RB Size=50, RB Offset=49	21.04	20.96	20.91
		RB Size=100, RB Offset=0	20.98	20.85	20.92

**Peak-to-average ratio (PAR)**

Modulation	Middle Channel (dB)	PAR Limit (dB)	Result
16QAM (1RB Size)	4.53	13	Pass
16QAM (100%RB Size)	4.79	13	Pass

**QPSK:**

Frequency (MHz)	Receiver Reading (dBµV)	Turn table Angle Degree	Rx Antenna		Substituted			Absolute Level (dBm)	Limit (dBm)
			Height (m)	Polar (H/V)	Level (dBm)	Cable Loss (dB)	Antenna Gain (dB)		
Middle Channel									
1.4 MHz Bandwidth									
1732.50	79.37	161	2.1	H	15.8	0.40	8.52	23.92	30
1732.50	80.84	134	2.3	V	15.3	0.40	8.52	23.42	30
3 MHz Bandwidth									
1732.50	78.47	227	1.6	H	14.9	0.40	8.52	23.02	30
1732.50	79.84	335	2.0	V	14.3	0.40	8.52	22.42	30
5 MHz Bandwidth									
1732.50	78.27	346	1.1	H	14.7	0.40	8.52	22.82	30
1732.50	80.04	114	1.1	V	14.5	0.40	8.52	22.62	30
10 MHz Bandwidth									
1732.50	76.97	103	1.8	H	13.4	0.40	8.52	21.52	30
1732.50	78.74	150	1.0	V	13.2	0.40	8.52	21.32	30
15 MHz Bandwidth									
1732.50	75.57	164	1.6	H	12.0	0.40	8.52	20.12	30
1732.50	76.14	326	2.4	V	10.6	0.40	8.52	18.72	30
20 MHz Bandwidth									
1732.50	75.67	171	2.1	H	12.1	0.40	8.52	20.22	30
1732.50	76.94	185	2.2	V	11.4	0.40	8.52	19.52	30

**16QAM:**

Frequency (MHz)	Receiver Reading (dBµV)	Turn table Angle Degree	Rx Antenna		Substituted			Absolute Level (dBm)	Limit (dBm)
			Height (m)	Polar (H/V)	Level (dBm)	Cable Loss (dB)	Antenna Gain (dB)		
Middle Channel									
1.4 MHz Bandwidth									
1732.50	79.07	336	1.3	H	15.5	0.40	8.52	23.62	30
1732.50	80.94	298	1.9	V	15.4	0.40	8.52	23.52	30
3 MHz Bandwidth									
1732.50	78.47	254	2.2	H	14.9	0.40	8.52	23.02	30
1732.50	79.94	100	2.3	V	14.4	0.40	8.52	22.52	30
5 MHz Bandwidth									
1732.50	78.77	318	1.5	H	15.2	0.40	8.52	23.32	30
1732.50	79.24	26	2.0	V	13.7	0.40	8.52	21.82	30
10 MHz Bandwidth									
1732.50	76.97	89	2.5	H	13.4	0.40	8.52	21.52	30
1732.50	79.14	27	1.6	V	13.6	0.40	8.52	21.72	30
15 MHz Bandwidth									
1732.50	76.77	344	2.1	H	13.2	0.40	8.52	21.32	30
1732.50	78.34	5	1.3	V	12.8	0.40	8.52	20.92	30
20 MHz Bandwidth									
1732.50	75.67	323	1.2	H	12.1	0.40	8.52	20.22	30
1732.50	77.64	108	1.6	V	12.1	0.40	8.52	20.22	30



**LTE Band 5:**

**Maximum Output Power**

Bandwidth (MHz)	Modulation	RB size/RB Offset	Low Channel (dBm)	Middle Channel (dBm)	High Channel (dBm)
1.4	QPSK	RB Size=1, RB Offset=0	23.10	23.07	23.19
		RB Size=1, RB Offset=2	23.07	23.05	23.05
		RB Size=1, RB Offset=5	23.13	23.09	23.1
		RB Size=3, RB Offset=0	22.98	22.90	22.87
		RB Size=3, RB Offset=1	23.03	22.87	22.93
		RB Size=3, RB Offset=2	23.04	22.88	22.88
		RB Size=6, RB Offset=0	21.94	21.90	21.87
	16QAM	RB Size=1, RB Offset=0	22.33	22.20	22.1
		RB Size=1, RB Offset=2	22.34	22.29	22.32
		RB Size=1, RB Offset=5	22.12	22.03	21.95
		RB Size=3, RB Offset=0	22.07	22.04	22.11
		RB Size=3, RB Offset=1	22.30	22.23	22.22
		RB Size=3, RB Offset=2	22.25	22.21	22.28
		RB Size=6, RB Offset=0	20.37	20.38	20.34
3.0	QPSK	RB Size=1, RB Offset=0	22.84	22.77	22.83
		RB Size=1, RB Offset=7	22.95	22.80	22.81
		RB Size=1, RB Offset=14	22.85	22.86	22.9
		RB Size=8, RB Offset=0	22.09	21.97	21.95
		RB Size=8, RB Offset=4	21.97	21.85	21.93
		RB Size=8, RB Offset=7	21.90	21.84	21.79
		RB Size=15, RB Offset=0	21.98	21.96	21.95
	16QAM	RB Size=1, RB Offset=0	21.65	21.59	21.58
		RB Size=1, RB Offset=7	21.68	21.65	21.65
		RB Size=1, RB Offset=14	21.76	21.59	21.59
		RB Size=8, RB Offset=0	21.36	21.25	21.27
		RB Size=8, RB Offset=4	21.45	21.28	21.22
		RB Size=8, RB Offset=7	21.08	20.92	20.95
		RB Size=15, RB Offset=0	20.81	20.70	20.79

Bandwidth (MHz)	Modulation	RB size/RB Offset	Low Channel (dBm)	Middle Channel (dBm)	High Channel (dBm)
5.0	QPSK	RB Size=1, RB Offset=0	23.05	23.05	23.11
		RB Size=1, RB Offset=12	22.11	22.05	22.12
		RB Size=1, RB Offset=24	23.17	22.99	23.09
		RB Size=12, RB Offset=0	21.90	21.81	21.74
		RB Size=12, RB Offset=6	21.98	21.92	21.91
		RB Size=12, RB Offset=11	21.97	21.87	21.79
		RB Size=25, RB Offset=0	21.97	21.89	21.91
	16QAM	RB Size=1, RB Offset=0	21.35	21.37	21.41
		RB Size=1, RB Offset=12	21.66	21.54	21.52
		RB Size=1, RB Offset=24	21.53	21.53	21.56
		RB Size=12, RB Offset=0	20.86	20.85	20.82
		RB Size=12, RB Offset=6	21.17	21.02	21.12
		RB Size=12, RB Offset=11	20.98	20.98	21.08
		RB Size=25, RB Offset=0	20.98	20.81	20.89
10.0	QPSK	RB Size=1, RB Offset=0	22.82	22.80	22.84
		RB Size=1, RB Offset=24	22.95	22.78	22.79
		RB Size=1, RB Offset=49	22.92	22.81	22.84
		RB Size=25, RB Offset=0	21.86	21.83	21.83
		RB Size=25, RB Offset=12	21.92	21.91	21.97
		RB Size=25, RB Offset=24	22.07	21.91	21.85
		RB Size=50, RB Offset=0	22.01	21.88	21.86
	16QAM	RB Size=1, RB Offset=0	21.82	21.70	21.77
		RB Size=1, RB Offset=24	22.54	22.45	22.41
		RB Size=1, RB Offset=49	21.41	21.41	21.34
		RB Size=25, RB Offset=0	20.97	20.85	20.92
		RB Size=25, RB Offset=12	20.94	20.96	20.99
		RB Size=25, RB Offset=24	20.96	20.96	20.98
		RB Size=50, RB Offset=0	21.02	20.92	21.02

**Peak-to-average ratio (PAR)**

Modulation	Middle Channel (dB)	PAR Limit (dB)	Result
16QAM (1RB Size)	4.64	13	Pass
16QAM (100%RB Size)	4.31	13	Pass

**QPSK:**

Frequency (MHz)	Receiver Reading (dBμV)	Turn table Angle Degree	Rx Antenna		Substituted			Absolute Level (dBm)	Limit (dBm)
			Height (m)	Polar (H/V)	Level (dBm)	Cable Loss (dB)	Antenna Gain (dB)		
Middle Channel									
1.4 MHz Bandwidth									
836.5	82.81	188	2.1	H	12.6	0.26	4.75	17.09	38.45
836.5	91.73	353	1.3	V	17.5	0.26	4.75	21.99	38.45
3 MHz Bandwidth									
836.5	80.94	112	1.4	H	10.7	0.26	4.75	15.19	38.45
836.5	88.26	96	1.1	V	14.0	0.26	4.75	18.49	38.45
5 MHz Bandwidth									
836.5	80.84	85	1.3	H	10.6	0.26	4.75	15.09	38.45
836.5	88.16	205	1.1	V	13.9	0.26	4.75	18.39	38.45
10 MHz Bandwidth									
836.5	80.74	34	1.1	H	10.5	0.26	4.75	14.99	38.45
836.5	88.16	124	1.4	V	13.9	0.26	4.75	18.39	38.45

**16QAM:**

Frequency (MHz)	Receiver Reading (dBµV)	Turn table Angle Degree	Rx Antenna		Substituted			Absolute Level (dBm)	Limit (dBm)
			Height (m)	Polar (H/V)	SG Level (dBm)	Cable Loss (dB)	Antenna Gain (dB)		
Middle Channel									
1.4 MHz Bandwidth									
836.5	81.24	112	1.2	H	11.0	0.26	4.75	15.49	38.45
836.5	88.46	96	1.3	V	14.2	0.26	4.75	18.69	38.45
3 MHz Bandwidth									
836.5	81.44	17	1.1	H	11.2	0.26	4.75	15.69	38.45
836.5	88.36	46	1.5	V	14.1	0.26	4.75	18.59	38.45
5 MHz Bandwidth									
836.5	81.14	174	1.5	H	10.9	0.26	4.75	15.39	38.45
836.5	87.86	63	1.2	V	13.6	0.26	4.75	18.09	38.45
10 MHz Bandwidth									
836.5	81.14	112	1.2	H	10.9	0.26	4.75	15.39	38.45
836.5	87.66	96	1.3	V	13.4	0.26	4.75	17.89	38.45

**LTE Band 7**

Bandwidth (MHz)	Modulation	RB size/RB Offset	Low Channel (dBm)	Middle Channel (dBm)	High Channel (dBm)
5.0	QPSK	RB Size=1, RB Offset=0	22.30	22.21	22.33
		RB Size=1, RB Offset=12	22.69	22.56	22.49
		RB Size=1, RB Offset=24	22.51	22.42	22.46
		RB Size=12, RB Offset=0	21.66	21.49	21.39
		RB Size=12, RB Offset=6	21.60	21.48	21.44
		RB Size=12, RB Offset=11	21.52	21.50	21.50
		RB Size=25, RB Offset=0	21.56	21.47	21.40
	16QAM	RB Size=1, RB Offset=0	21.12	21.02	21.06
		RB Size=1, RB Offset=12	21.90	21.74	21.69
		RB Size=1, RB Offset=24	21.33	21.17	21.26
		RB Size=12, RB Offset=0	20.79	20.73	20.64
		RB Size=12, RB Offset=6	20.82	20.78	20.82
		RB Size=12, RB Offset=11	20.65	20.66	20.73
		RB Size=25, RB Offset=0	20.62	20.53	20.59
10.0	QPSK	RB Size=1, RB Offset=0	22.34	22.30	22.34
		RB Size=1, RB Offset=24	22.67	22.54	22.51
		RB Size=1, RB Offset=49	22.48	22.36	22.26
		RB Size=25, RB Offset=0	21.63	21.52	21.47
		RB Size=25, RB Offset=12	21.70	21.55	21.64
		RB Size=25, RB Offset=24	21.65	21.59	21.56
		RB Size=50, RB Offset=0	21.71	21.56	21.59
	16QAM	RB Size=1, RB Offset=0	21.01	20.91	20.98
		RB Size=1, RB Offset=24	21.66	21.62	21.57
		RB Size=1, RB Offset=49	21.02	20.99	20.9
		RB Size=25, RB Offset=0	20.63	20.50	20.57
		RB Size=25, RB Offset=12	20.91	20.78	20.86
		RB Size=25, RB Offset=24	20.85	20.72	20.81
		RB Size=50, RB Offset=0	20.72	20.54	20.59

Bandwidth (MHz)	Modulation	RB size/RB Offset	Low Channel (dBm)	Middle Channel (dBm)	High Channel (dBm)
15.0	QPSK	RB Size=1, RB Offset=0	22.50	22.44	22.5
		RB Size=1, RB Offset=37	22.64	22.51	22.56
		RB Size=1, RB Offset=74	22.46	22.47	22.42
		RB Size=36, RB Offset=0	21.61	21.47	21.42
		RB Size=36, RB Offset=18	21.64	21.52	21.57
		RB Size=36, RB Offset=37	21.56	21.50	21.54
		RB Size=75, RB Offset=0	21.52	21.48	21.45
	16QAM	RB Size=1, RB Offset=0	21.27	21.28	21.26
		RB Size=1, RB Offset=37	21.96	21.85	21.81
		RB Size=1, RB Offset=74	21.43	21.32	21.31
		RB Size=36, RB Offset=0	20.64	20.61	20.51
		RB Size=36, RB Offset=18	20.76	20.62	20.67
		RB Size=36, RB Offset=37	20.62	20.54	20.57
		RB Size=75, RB Offset=0	20.67	20.56	20.66
20.0	QPSK	RB Size=1, RB Offset=0	22.48	22.41	22.44
		RB Size=1, RB Offset=49	22.72	22.79	22.92
		RB Size=1, RB Offset=99	22.43	22.45	22.59
		RB Size=50, RB Offset=0	21.41	21.48	21.62
		RB Size=50, RB Offset=24	21.54	21.51	21.66
		RB Size=50, RB Offset=49	21.51	21.60	21.69
		RB Size=100, RB Offset=0	21.49	21.52	21.60
	16QAM	RB Size=1, RB Offset=0	21.55	21.45	21.53
		RB Size=1, RB Offset=49	21.75	21.79	21.81
		RB Size=1, RB Offset=99	21.79	21.71	21.80
		RB Size=50, RB Offset=0	20.63	20.65	20.67
		RB Size=50, RB Offset=24	20.69	20.68	20.77
		RB Size=50, RB Offset=49	20.65	20.67	20.78
		RB Size=100, RB Offset=0	20.49	20.54	20.70

**Peak-to-average ratio (PAR)**

Modulation	Middle Channel (dB)	PAR Limit (dB)	Result
16QAM (1RB Size)	4.24	13	Pass
16QAM (100%RB Size)	4.57	13	Pass

**EIRP:**

**QPSK:**

Frequency (MHz)	Receiver Reading (dBµV)	Turn table Angle Degree	Rx Antenna		Substituted			Absolute Level (dBm)	Limit (dBm)
			Height (m)	Polar (H/V)	Level (dBm)	Cable Loss (dB)	Antenna Gain (dB)		
Middle Channel									
5 MHz Bandwidth									
2535.00	73.16	117	2.3	H	10.6	0.49	10.10	20.21	33
2535.00	76.17	284	1.4	V	12.9	0.49	10.10	22.51	33
10 MHz Bandwidth									
2535.00	71.46	153	1.3	H	8.9	0.49	10.10	18.51	33
2535.00	75.37	78	1.7	V	12.1	0.49	10.10	21.71	33
15 MHz Bandwidth									
2535.00	70.26	115	1.9	H	7.7	0.49	10.10	17.31	33
2535.00	71.87	170	1.2	V	8.6	0.49	10.10	18.21	33
20 MHz Bandwidth									
2535.00	70.36	269	2.5	H	7.8	0.49	10.10	17.41	33
2535.00	70.87	331	2.4	V	7.6	0.49	10.10	17.21	33

**16QAM:**

Frequency (MHz)	Receiver Reading (dBμV)	Turn table Angle Degree	Rx Antenna		Substituted			Absolute Level (dBm)	Limit (dBm)
			Height (m)	Polar (H/V)	Level (dBm)	Cable Loss (dB)	Antenna Gain (dB)		
Middle Channel									
5 MHz Bandwidth									
2535.00	69.96	271	1.6	H	7.4	0.49	10.10	17.01	33
2535.00	74.67	256	1.6	V	11.4	0.49	10.10	21.01	33
10 MHz Bandwidth									
2535.00	70.36	108	1.9	H	7.8	0.49	10.10	17.41	33
2535.00	74.07	358	1.9	V	10.8	0.49	10.10	20.41	33
15 MHz Bandwidth									
2535.00	68.76	175	2.2	H	6.2	0.49	10.10	15.81	33
2535.00	71.97	325	2.0	V	8.7	0.49	10.10	18.31	33
20 MHz Bandwidth									
2535.00	81.14	246	2.5	H	6.0	0.49	10.10	15.61	33
2535.00	89.66	102	2.4	V	8.1	0.49	10.10	17.71	33



**LTE Band 26 (814-824MHz):**

Bandwidth (MHz)	Modulation	RB size/RB Offset	Low Channel (dBm)	Middle Channel (dBm)	High Channel (dBm)
1.4	QPSK	RB Size=1, RB Offset=0	23.02	22.98	23.14
		RB Size=1, RB Offset=12	23.13	23.04	23.09
		RB Size=1, RB Offset=24	23.09	23.14	23.12
		RB Size=12, RB Offset=0	22.89	22.96	22.95
		RB Size=12, RB Offset=6	23.07	22.90	22.88
		RB Size=12, RB Offset=11	23.10	22.79	22.85
		RB Size=25, RB Offset=0	21.96	21.85	21.96
	16QAM	RB Size=1, RB Offset=0	22.40	22.14	22.13
		RB Size=1, RB Offset=12	22.36	22.28	22.29
		RB Size=1, RB Offset=24	22.05	22.13	21.87
		RB Size=12, RB Offset=0	22.03	21.99	22.17
		RB Size=12, RB Offset=6	22.32	22.32	22.19
		RB Size=12, RB Offset=11	22.17	22.17	22.27
		RB Size=25, RB Offset=0	20.37	20.35	20.29
3	QPSK	RB Size=1, RB Offset=0	22.81	22.84	22.9
		RB Size=1, RB Offset=24	23.04	22.74	22.71
		RB Size=1, RB Offset=49	22.93	22.78	22.99
		RB Size=25, RB Offset=0	22.15	21.94	21.97
		RB Size=25, RB Offset=12	22.02	21.92	21.97
		RB Size=25, RB Offset=24	21.95	21.8	21.73
		RB Size=50, RB Offset=0	21.93	21.94	21.93
	16QAM	RB Size=1, RB Offset=0	21.65	21.59	21.66
		RB Size=1, RB Offset=24	21.59	21.71	21.59
		RB Size=1, RB Offset=49	21.79	21.54	21.63
		RB Size=25, RB Offset=0	21.33	21.18	21.31
		RB Size=25, RB Offset=12	21.49	21.26	21.22
		RB Size=25, RB Offset=24	21.05	20.86	20.95
		RB Size=50, RB Offset=0	20.8	20.7	20.85

Bandwidth (MHz)	Modulation	RB size/RB Offset	Low Channel (dBm)	Middle Channel (dBm)	High Channel (dBm)
5	QPSK	RB Size=1, RB Offset=0	22.93	23.11	23.08
		RB Size=1, RB Offset=37	22.16	22.04	22.19
		RB Size=1, RB Offset=74	23.20	23.00	23.09
		RB Size=36, RB Offset=0	21.78	21.87	21.65
		RB Size=36, RB Offset=18	21.87	21.93	21.81
		RB Size=36, RB Offset=37	21.85	21.91	21.84
		RB Size=75, RB Offset=0	21.99	21.85	21.97
	16QAM	RB Size=1, RB Offset=0	21.29	21.43	21.47
		RB Size=1, RB Offset=37	21.58	21.42	21.54
		RB Size=1, RB Offset=74	21.54	21.57	21.59
		RB Size=36, RB Offset=0	20.86	20.74	20.78
		RB Size=36, RB Offset=18	21.14	21.01	21.14
		RB Size=36, RB Offset=37	21.03	20.97	21.06
		RB Size=75, RB Offset=0	21.04	20.81	20.95
10	QPSK	RB Size=1, RB Offset=0	/	22.78	/
		RB Size=1, RB Offset=49	/	22.79	/
		RB Size=1, RB Offset=99	/	22.85	/
		RB Size=50, RB Offset=0	/	21.73	/
		RB Size=50, RB Offset=24	/	21.95	/
		RB Size=50, RB Offset=49	/	21.83	/
		RB Size=100, RB Offset=0	/	21.81	/
	16QAM	RB Size=1, RB Offset=0	/	21.75	/
		RB Size=1, RB Offset=49	/	22.46	/
		RB Size=1, RB Offset=99	/	21.47	/
		RB Size=50, RB Offset=0	/	20.77	/
		RB Size=50, RB Offset=24	/	21.04	/
		RB Size=50, RB Offset=49	/	20.86	/
		RB Size=100, RB Offset=0	/	20.82	/

**Peak-to-average ratio (PAR)**

Modulation	Middle Channel (dB)	PAR Limit (dB)	Result
16QAM (1RB Size)	4.69	13	Pass
16QAM (100%RB Size)	4.37	13	Pass

**EIRP:**

**QPSK:**

Frequency (MHz)	Receiver Reading (dBμV)	Turn table Angle Degree	Rx Antenna		Substituted			Absolute Level (dBm)	Limit (dBm)
			Height (m)	Polar (H/V)	Level (dBm)	Cable Loss (dB)	Antenna Gain (dB)		
Middle Channel									
1.4 MHz Bandwidth									
819	80.21	122	1.2	H	10.0	0.26	4.75	14.49	50
819	87.93	87	1.6	V	13.7	0.26	4.75	18.19	50
3 MHz Bandwidth									
819	79.76	11	1.4	H	9.6	0.26	4.75	14.09	50
819	87.58	236	1.3	V	13.4	0.26	4.75	17.89	50
5 MHz Bandwidth									
819	79.56	105	1.2	H	9.4	0.26	4.75	13.89	50
819	87.38	33	1.5	V	13.2	0.26	4.75	17.69	50
10 MHz Bandwidth									
819	79.36	186	1.7	H	9.2	0.26	4.75	13.69	50
819	87.28	76	1.3	V	13.1	0.26	4.75	17.59	50

**16QAM:**

Frequency (MHz)	Receiver Reading (dBμV)	Turn table Angle Degree	Rx Antenna		Substituted			Absolute Level (dBm)	Limit (dBm)
			Height (m)	Polar (H/V)	Level (dBm)	Cable Loss (dB)	Antenna Gain (dB)		
Middle Channel									
1.4 MHz Bandwidth									
819	79.76	341	1.5	H	9.6	0.26	4.75	14.09	50
819	87.78	224	1.4	V	13.6	0.26	4.75	18.09	50
3 MHz Bandwidth									
819	79.56	102	1.7	H	9.4	0.26	4.75	13.89	50
819	87.68	97	1.3	V	13.5	0.26	4.75	17.99	50
5 MHz Bandwidth									
819	79.36	30	1.2	H	9.2	0.26	4.75	13.69	50
819	87.28	55	1.3	V	13.1	0.26	4.75	17.59	50
10 MHz Bandwidth									
819	79.26	145	1.2	H	9.1	0.26	4.75	13.59	50
819	87.18	210	1.3	V	13.0	0.26	4.75	17.49	50

**LTE Band 38**

Bandwidth (MHz)	Modulation	RB size/RB Offset	Low Channel (dBm)	Middle Channel (dBm)	High Channel (dBm)
5.0	QPSK	RB Size=1, RB Offset=0	22.75	22.78	22.91
		RB Size=1, RB Offset=12	22.84	22.76	22.74
		RB Size=1, RB Offset=24	22.66	22.79	22.78
		RB Size=12, RB Offset=0	22.05	22.03	22.04
		RB Size=12, RB Offset=6	21.99	22.12	22.14
		RB Size=12, RB Offset=11	22.07	21.98	22.00
		RB Size=25, RB Offset=0	22.06	22.02	22.05
	16QAM	RB Size=1, RB Offset=0	21.67	21.68	21.64
		RB Size=1, RB Offset=12	21.91	21.91	21.85
		RB Size=1, RB Offset=24	21.36	21.44	21.43
		RB Size=12, RB Offset=0	21.00	20.90	20.92
		RB Size=12, RB Offset=6	21.03	20.89	20.96
		RB Size=12, RB Offset=11	20.86	20.86	21.02
		RB Size=25, RB Offset=0	20.75	20.83	20.87
10.0	QPSK	RB Size=1, RB Offset=0	22.93	22.27	22.84
		RB Size=1, RB Offset=24	22.78	22.23	22.75
		RB Size=1, RB Offset=49	22.68	21.84	22.68
		RB Size=25, RB Offset=0	22.15	21.21	22.03
		RB Size=25, RB Offset=12	21.94	21.34	22.03
		RB Size=25, RB Offset=24	22.01	21.42	22.14
		RB Size=50, RB Offset=0	22.16	21.31	22.11
	16QAM	RB Size=1, RB Offset=0	21.64	23.5	21.65
		RB Size=1, RB Offset=24	21.94	23.56	21.77
		RB Size=1, RB Offset=49	21.51	23.32	21.32
		RB Size=25, RB Offset=0	20.99	22.26	20.97
		RB Size=25, RB Offset=12	20.91	22.17	20.84
		RB Size=25, RB Offset=24	21.04	22.21	20.97
		RB Size=50, RB Offset=0	20.89	22.33	20.94

Bandwidth (MHz)	Modulation	RB size/RB Offset	Low Channel (dBm)	Middle Channel (dBm)	High Channel (dBm)
15.0	QPSK	RB Size=1, RB Offset=0	22.93	23.10	22.94
		RB Size=1, RB Offset=37	22.78	22.86	22.90
		RB Size=1, RB Offset=74	22.68	23.39	23.15
		RB Size=36, RB Offset=0	22.15	21.95	21.96
		RB Size=36, RB Offset=18	21.94	22.01	21.87
		RB Size=36, RB Offset=37	22.01	21.92	22.04
		RB Size=75, RB Offset=0	22.16	21.81	21.9
	16QAM	RB Size=1, RB Offset=0	21.64	21.62	21.56
		RB Size=1, RB Offset=37	21.94	21.76	21.64
		RB Size=1, RB Offset=74	21.51	21.51	21.37
		RB Size=36, RB Offset=0	20.99	20.79	20.74
		RB Size=36, RB Offset=18	20.91	20.85	20.68
		RB Size=36, RB Offset=37	21.04	20.93	20.77
		RB Size=75, RB Offset=0	20.84	20.85	20.78
20.0	QPSK	RB Size=1, RB Offset=0	22.93	21.92	22.84
		RB Size=1, RB Offset=49	22.78	22.86	22.75
		RB Size=1, RB Offset=99	22.68	22.79	22.68
		RB Size=50, RB Offset=0	22.15	21.99	22.03
		RB Size=50, RB Offset=24	21.94	21.82	22.03
		RB Size=50, RB Offset=49	22.01	22.06	22.14
		RB Size=100, RB Offset=0	22.16	21.88	22.11
	16QAM	RB Size=1, RB Offset=0	21.64	21.18	21.65
		RB Size=1, RB Offset=49	21.94	21.38	21.77
		RB Size=1, RB Offset=99	21.51	21.28	21.32
		RB Size=50, RB Offset=0	20.99	21.05	20.97
		RB Size=50, RB Offset=24	20.91	20.97	20.84
		RB Size=50, RB Offset=49	21.04	20.93	20.97
		RB Size=100, RB Offset=0	20.92	20.95	20.90

**Peak-to-average ratio (PAR)**

Modulation	Middle Channel (dB)	PAR Limit (dB)	Result
16QAM (1RB Size)	4.56	13	Pass
16QAM (100%RB Size)	4.66	13	Pass

**EIRP:**

**QPSK:**

Frequency (MHz)	Receiver Reading (dBμV)	Turn table Angle Degree	Rx Antenna		Substituted			Absolute Level (dBm)	Limit (dBm)
			Height (m)	Polar (H/V)	Level (dBm)	Cable Loss (dB)	Antenna Gain (dB)		
Middle Channel									
5 MHz Bandwidth									
2595.00	74.22	98	1.1	H	11.7	0.50	9.96	21.16	33
2595.00	76.25	211	1.7	V	13.0	0.50	9.96	22.46	33
10 MHz Bandwidth									
2595.00	73.32	167	2.1	H	10.8	0.50	9.96	20.26	33
2595.00	75.65	138	2.3	V	12.4	0.50	9.96	21.86	33
15 MHz Bandwidth									
2595.00	73.32	299	1.6	H	10.8	0.50	9.96	20.26	33
2595.00	75.45	151	1.6	V	12.2	0.50	9.96	21.66	33
20 MHz Bandwidth									
2595.00	72.42	261	1.2	H	9.9	0.50	9.96	19.36	33
2595.00	75.65	226	1.8	V	12.4	0.50	9.96	21.86	33

**16QAM:**

Frequency (MHz)	Receiver Reading (dBμV)	Turn table Angle Degree	Rx Antenna		Substituted			Absolute Level (dBm)	Limit (dBm)
			Height (m)	Polar (H/V)	Level (dBm)	Cable Loss (dB)	Antenna Gain (dB)		
Middle Channel									
5 MHz Bandwidth									
2595.00	71.32	239	2.3	H	8.8	0.50	9.96	18.26	33
2595.00	75.65	159	1.4	V	12.4	0.50	9.96	21.86	33
10 MHz Bandwidth									
2595.00	70.02	313	1.8	H	7.5	0.50	9.96	16.96	33
2595.00	74.65	131	2.1	V	11.4	0.50	9.96	20.86	33
15 MHz Bandwidth									
2595.00	70.62	160	2.0	H	8.1	0.50	9.96	17.56	33
2595.00	74.35	259	1.7	V	11.1	0.50	9.96	20.56	33
20 MHz Bandwidth									
2595.00	69.92	162	1.6	H	7.4	0.50	9.96	16.86	33
2595.00	73.15	20	1.8	V	9.9	0.50	9.96	19.36	33



**LTE Band 41**

Bandwidth (MHz)	Modulation	RB size/RB Offset	Low Channel (dBm)	Middle Channel (dBm)	High Channel (dBm)
5.0	QPSK	RB Size=1, RB Offset=0	23.34	23.31	23.20
		RB Size=1, RB Offset=12	23.43	23.55	23.41
		RB Size=1, RB Offset=24	23.46	23.48	23.29
		RB Size=12, RB Offset=0	22.31	22.45	22.37
		RB Size=12, RB Offset=6	22.55	22.51	22.55
		RB Size=12, RB Offset=11	22.38	22.37	22.25
		RB Size=25, RB Offset=0	21.98	22.04	22.03
	16QAM	RB Size=1, RB Offset=0	21.73	21.91	21.75
		RB Size=1, RB Offset=12	22.16	22.23	22.05
		RB Size=1, RB Offset=24	21.60	21.75	21.74
		RB Size=12, RB Offset=0	20.99	21.01	20.85
		RB Size=12, RB Offset=6	20.75	20.93	20.82
		RB Size=12, RB Offset=11	20.94	21.05	20.89
		RB Size=25, RB Offset=0	20.61	20.67	20.61
10.0	QPSK	RB Size=1, RB Offset=0	23.31	23.43	23.42
		RB Size=1, RB Offset=24	23.33	23.31	23.19
		RB Size=1, RB Offset=49	23.38	23.47	23.37
		RB Size=25, RB Offset=0	22.42	22.48	22.42
		RB Size=25, RB Offset=12	22.56	22.63	22.51
		RB Size=25, RB Offset=24	22.48	22.50	22.32
		RB Size=50, RB Offset=0	22.28	22.38	22.39
	16QAM	RB Size=1, RB Offset=0	22.18	22.30	22.34
		RB Size=1, RB Offset=24	23.02	23.04	23.06
		RB Size=1, RB Offset=49	22.28	22.31	22.25
		RB Size=25, RB Offset=0	21.5	21.46	21.28
		RB Size=25, RB Offset=12	21.16	21.25	21.17
		RB Size=25, RB Offset=24	21.31	21.36	21.40
		RB Size=50, RB Offset=0	21.24	21.37	21.18

Bandwidth (MHz)	Modulation	RB size/RB Offset	Low Channel (dBm)	Middle Channel (dBm)	High Channel (dBm)
15.0	QPSK	RB Size=1, RB Offset=0	22.76	22.83	22.78
		RB Size=1, RB Offset=37	23.10	23.26	23.15
		RB Size=1, RB Offset=74	23.34	23.49	23.32
		RB Size=36, RB Offset=0	22.22	22.21	22.09
		RB Size=36, RB Offset=18	22.47	22.46	22.41
		RB Size=36, RB Offset=37	22.32	22.32	22.22
		RB Size=75, RB Offset=0	22.18	22.29	22.17
	16QAM	RB Size=1, RB Offset=0	21.93	22.10	22.14
		RB Size=1, RB Offset=37	22.92	23.03	22.86
		RB Size=1, RB Offset=74	21.99	22.15	22.39
		RB Size=36, RB Offset=0	20.57	20.59	20.64
		RB Size=36, RB Offset=18	20.63	20.70	20.57
		RB Size=36, RB Offset=37	20.72	20.77	20.78
		RB Size=75, RB Offset=0	20.71	20.83	20.66
20.0	QPSK	RB Size=1, RB Offset=0	23.25	23.31	23.25
		RB Size=1, RB Offset=49	23.47	23.57	23.38
		RB Size=1, RB Offset=99	23.04	23.17	23.22
		RB Size=50, RB Offset=0	22.45	22.42	22.40
		RB Size=50, RB Offset=24	22.28	22.33	22.32
		RB Size=50, RB Offset=49	22.37	22.40	22.31
		RB Size=100, RB Offset=0	22.20	22.25	22.34
	16QAM	RB Size=1, RB Offset=0	21.07	21.17	20.99
		RB Size=1, RB Offset=49	21.13	21.15	20.99
		RB Size=1, RB Offset=99	21.51	21.55	21.5
		RB Size=50, RB Offset=0	20.51	20.68	20.6
		RB Size=50, RB Offset=24	20.81	20.97	20.96
		RB Size=50, RB Offset=49	20.62	20.72	20.75
		RB Size=100, RB Offset=0	20.65	20.69	20.73

**Peak-to-average ratio (PAR)**

Modulation	Middle Channel (dB)	PAR Limit (dB)	Result
16QAM (1RB Size)	4.76	13	Pass
16QAM (100%RB Size)	4.99	13	Pass

**EIRP:**

**QPSK:**

Frequency (MHz)	Receiver Reading (dBμV)	Turn table Angle Degree	Rx Antenna		Substituted			Absolute Level (dBm)	Limit (dBm)
			Height (m)	Polar (H/V)	Level (dBm)	Cable Loss (dB)	Antenna Gain (dB)		
Middle Channel									
5 MHz Bandwidth									
2593.00	71.52	195	1.9	H	9.0	0.50	9.96	18.46	33
2593.00	73.65	19	1.9	V	10.4	0.50	9.96	19.86	33
10 MHz Bandwidth									
2593.00	71.12	175	2.3	H	8.6	0.50	9.96	18.06	33
2593.00	72.85	327	1.8	V	9.6	0.50	9.96	19.06	33
15 MHz Bandwidth									
2593.00	70.82	163	2.4	H	8.3	0.50	9.96	17.76	33
2593.00	72.55	203	2.1	V	9.3	0.50	9.96	18.76	33
20 MHz Bandwidth									
2593.00	69.32	315	2.2	H	6.8	0.50	9.96	16.26	33
2593.00	71.95	335	1.7	V	8.7	0.50	9.96	18.16	33

**16QAM:**

Frequency (MHz)	Receiver Reading (dBμV)	Turn table Angle Degree	Rx Antenna		Substituted			Absolute Level (dBm)	Limit (dBm)
			Height (m)	Polar (H/V)	Level (dBm)	Cable Loss (dB)	Antenna Gain (dB)		
Middle Channel									
5 MHz Bandwidth									
2593.00	72.62	117	2.3	H	10.1	0.50	9.96	19.56	33
2593.00	73.85	249	1.2	V	10.6	0.50	9.96	20.06	33
10 MHz Bandwidth									
2593.00	70.12	239	1.1	H	7.6	0.50	9.96	17.06	33
2593.00	73.55	44	1.6	V	10.3	0.50	9.96	19.76	33
15 MHz Bandwidth									
2593.00	70.92	160	2.2	H	8.4	0.50	9.96	17.86	33
2593.00	73.45	224	1.7	V	10.2	0.50	9.96	19.66	33
20 MHz Bandwidth									
2593.00	70.72	354	1.9	H	8.2	0.50	9.96	17.66	33
2593.00	72.05	74	1.3	V	8.8	0.50	9.96	18.26	33

**Note:**

All above data were tested with no amplifier

Absolute Level = SG Level - Cable loss + Antenna Gain

Margin = Limit- Absolute Level

**FCC §2.1049, §22.917, §22.905 & §24.238 & §27.53 & §90.209 - OCCUPIED BANDWIDTH**

**Applicable Standard**

FCC 47 §2.1049, §22.917, §22.905, §24.238 , §27.53 and §90.209.

**Test Procedure**

The RF output of the transmitter was connected to the simulator and the spectrum analyzer through sufficient attenuation.

The resolution bandwidth of the spectrum analyzer was set at 1% -5%of the OBW and the 26 dB & 99% bandwidth was recorded.

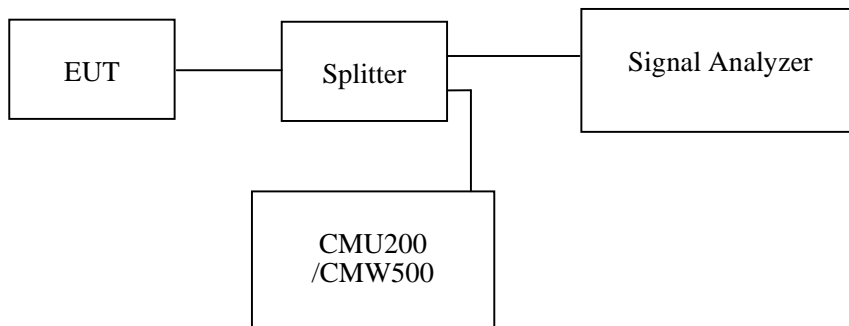

**Test Data**

**Environmental Conditions**

<b>Temperature:</b>	23~25 °C
<b>Relative Humidity:</b>	48~55 %
<b>ATM Pressure:</b>	100.0~101.0 kPa

*The testing was performed by Nefertari Xu from 2017-03-16 to 2017-05-23.*

*EUT operation mode: Transmitting*

Test Result: Compliance. Please refer to the following tables and plots.

**Cellular Band (Part 22H)**

Mode	Frequency (MHz)	99% Occupied Bandwidth (kHz)	26 dB Emission Bandwidth (kHz)
GSM(GMSK)	836.6	242.5	308.6
EGPRS(8PSK)	836.6	244.5	312.6

Mode	Frequency (MHz)	99% Occupied Bandwidth (kHz)	26 dB Emission Bandwidth (kHz)
CDMA RC3 SO55(LOOKBACK)	836.52	1.275	1.431
CDMA (EV-DO,FTAP Rate:307.2Kpbs 2 Slot.QPSK RTAP Rate: 153.6 Kpbs)	836.52	1.275	1.437

**PCS Band (Part 24E)**

Mode	Frequency (MHz)	99% Occupied Bandwidth (kHz)	26 dB Emission Bandwidth (kHz)
GSM(GMSK)	1880.0	242.5	310.6
EGPRS(8PSK)	1880.0	248.5	314.6

**Cellular Band (Part 22H)**

**26 dB Emissions & 99% Occupied Bandwidth for GSM (GMSK) Mode**

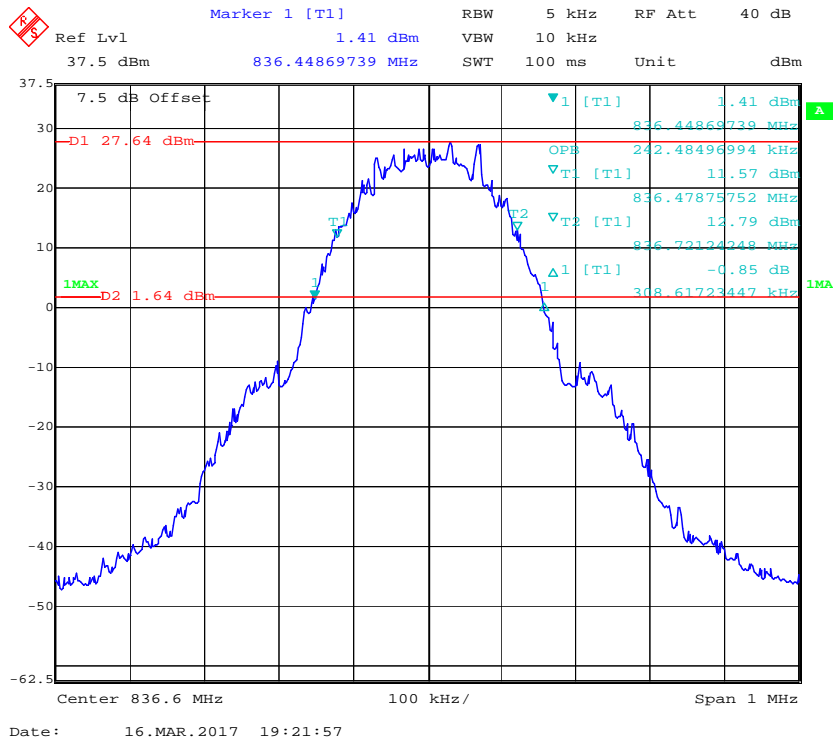

**26 dB Emissions & 99% Occupied Bandwidth for EGPRS (8PSK) Mode**

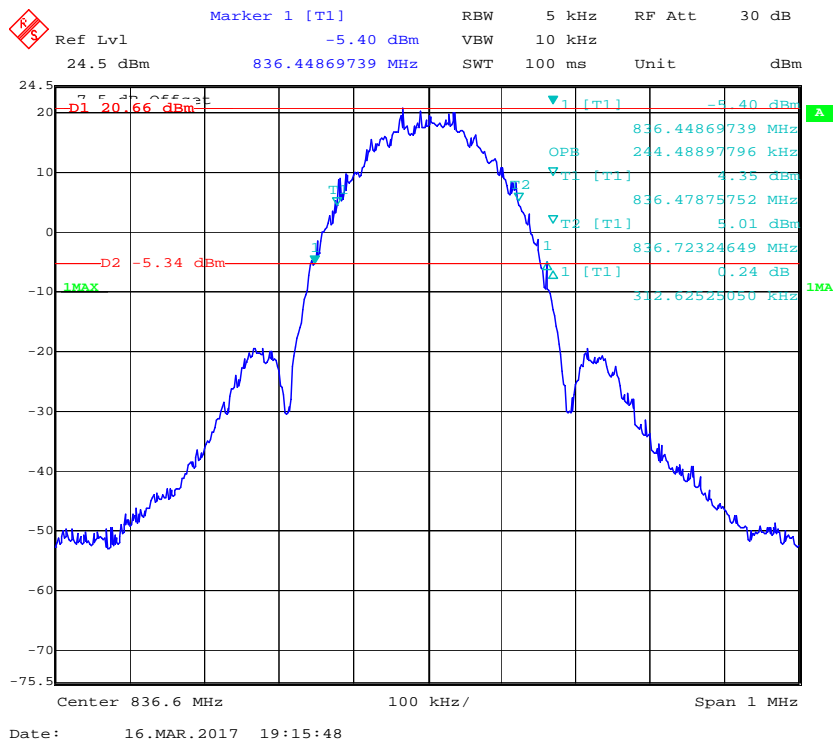

**26 dB Emissions & 99% Occupied Bandwidth for CDMA Mode, Middle channel**

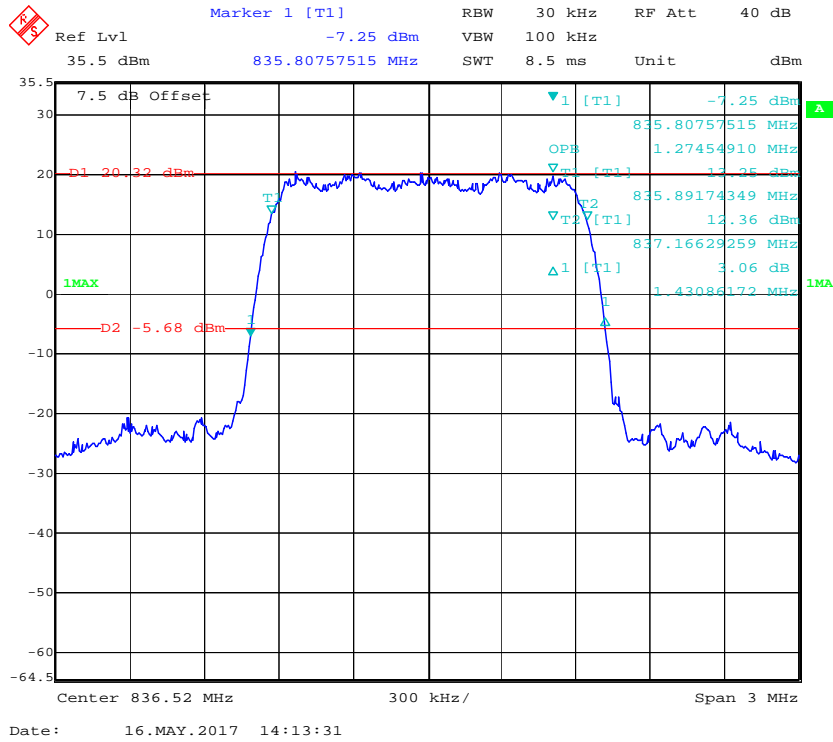

**26 dB Emissions & 99% Occupied Bandwidth for CDMA (EV-DO) Mode, Middle channel**

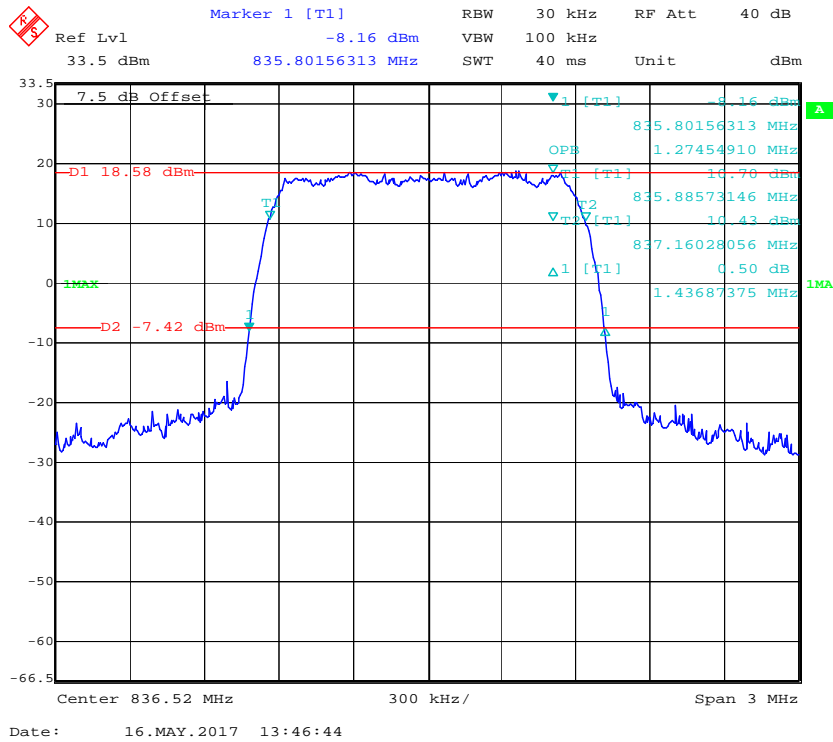



PCS Band (Part 24E)

26 dB Emissions & 99% Occupied Bandwidth for GSM (GMSK) Mode

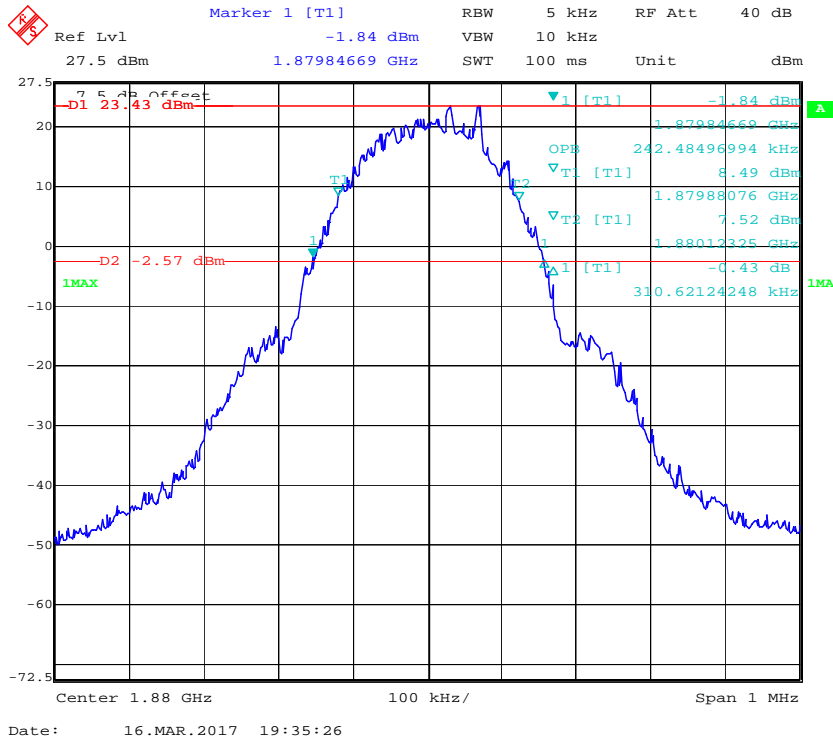

26 dB Emissions & 99% Occupied Bandwidth for EGPRS (8PSK) Mode

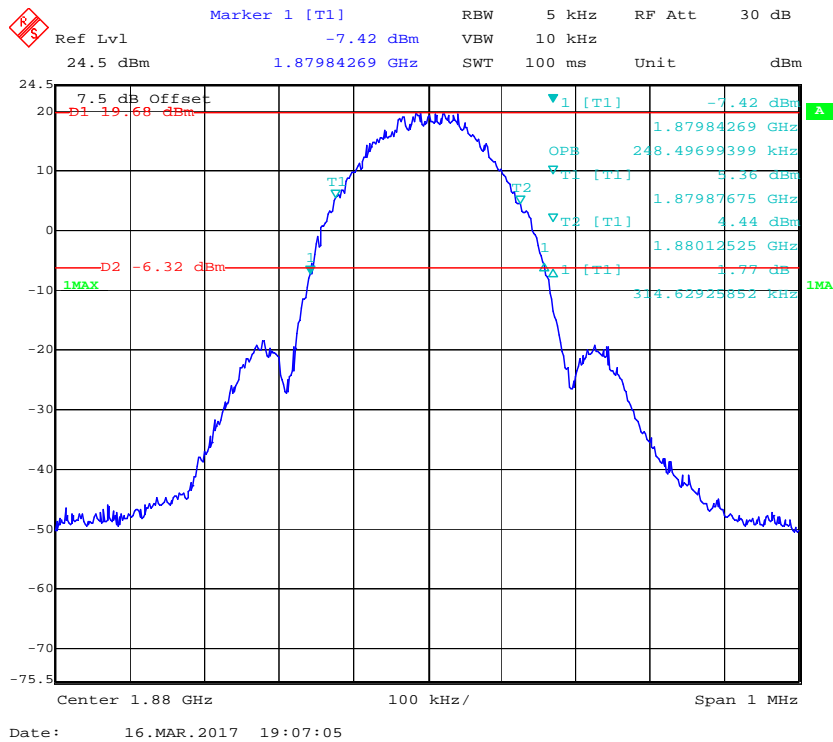

**LTE Band 2: (Middle Channel)**

<b>Bandwidth (MHz)</b>	<b>Modulation</b>	<b>99% Occupied Bandwidth (MHz)</b>	<b>26 dB Emission Bandwidth (MHz)</b>
1.4	QPSK	1.106	1.335
	16QAM	1.106	1.305
3.0	QPSK	2.693	2.934
	16QAM	2.705	2.970
5.0	QPSK	4.509	5.010
	16QAM	4.509	5.070
10.0	QPSK	8.978	9.860
	16QAM	8.978	9.860
15.0	QPSK	13.527	14.910
	16QAM	13.407	14.669
20.0	QPSK	17.916	19.299
	16QAM	17.976	19.178

**QPSK (1.4 MHz) - 99% Occupied Bandwidth, Middle channel**

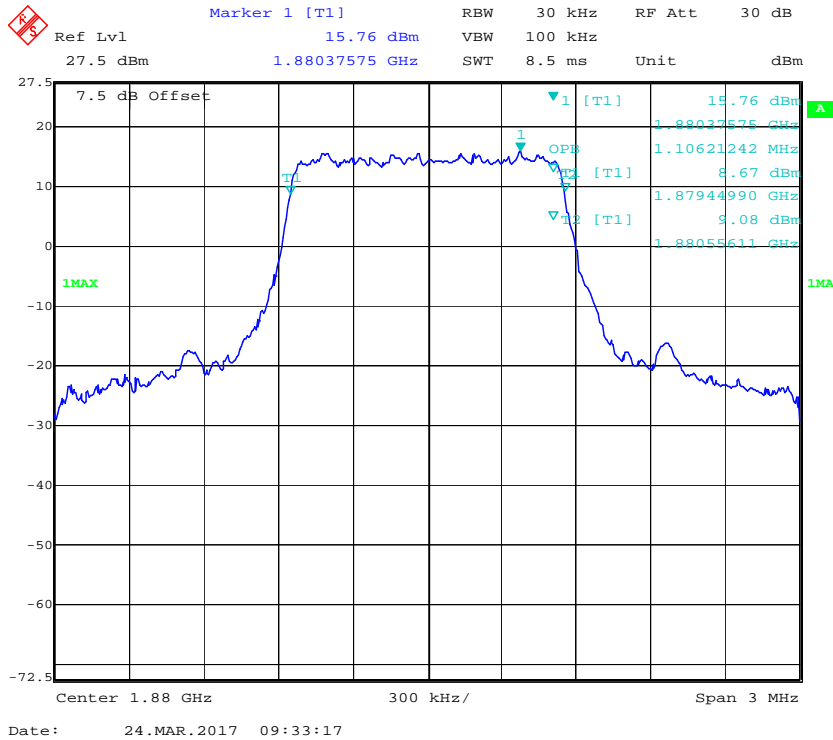

**16-QAM (1.4 MHz) - 99% Occupied Bandwidth, Middle channel**

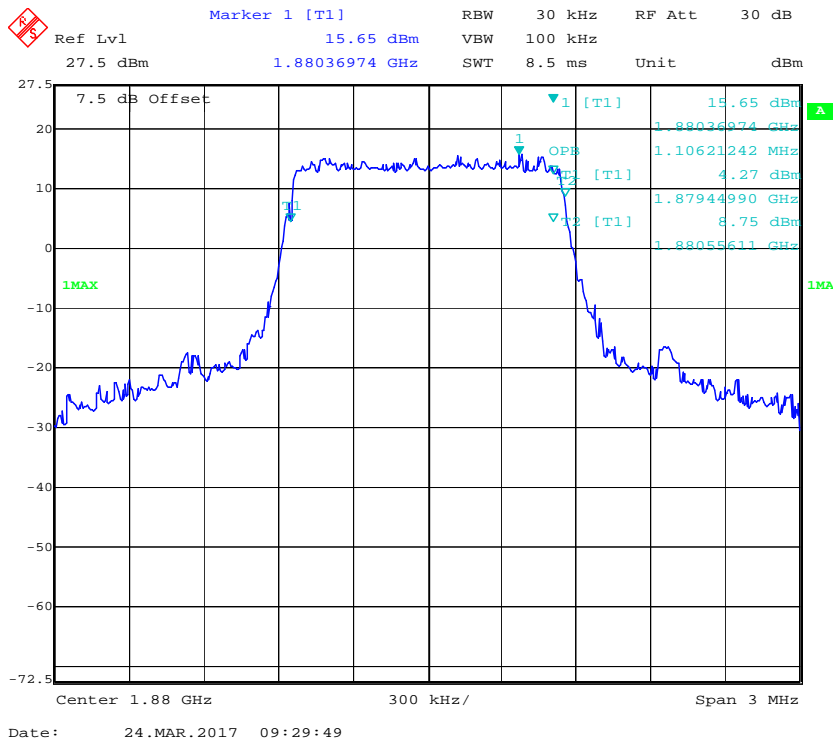



**QPSK (5.0 MHz) - 99% Occupied Bandwidth, Middle channel**

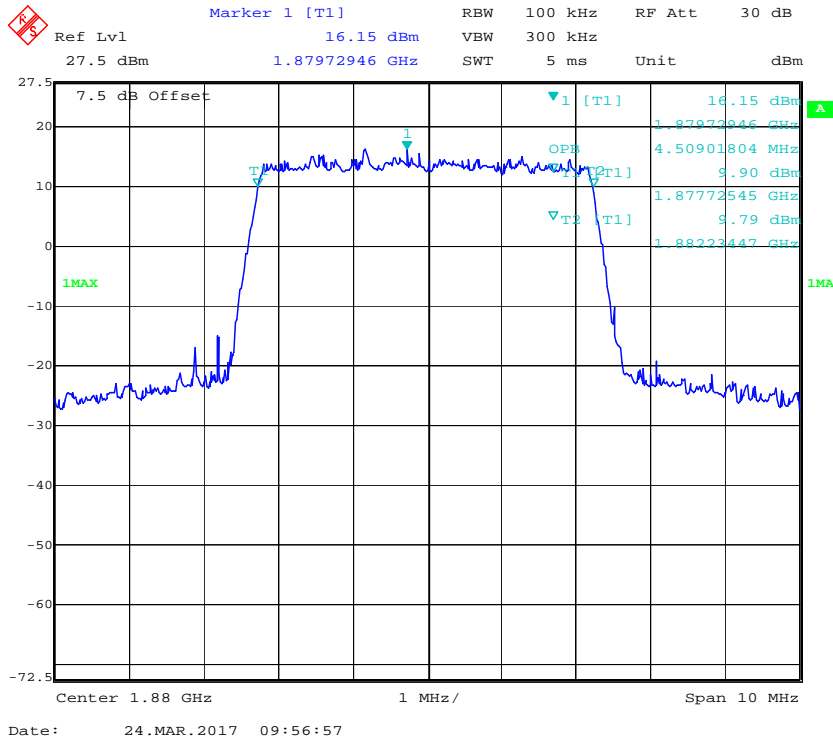

**16-QAM (5.0 MHz) - 99% Occupied Bandwidth, Middle channel**

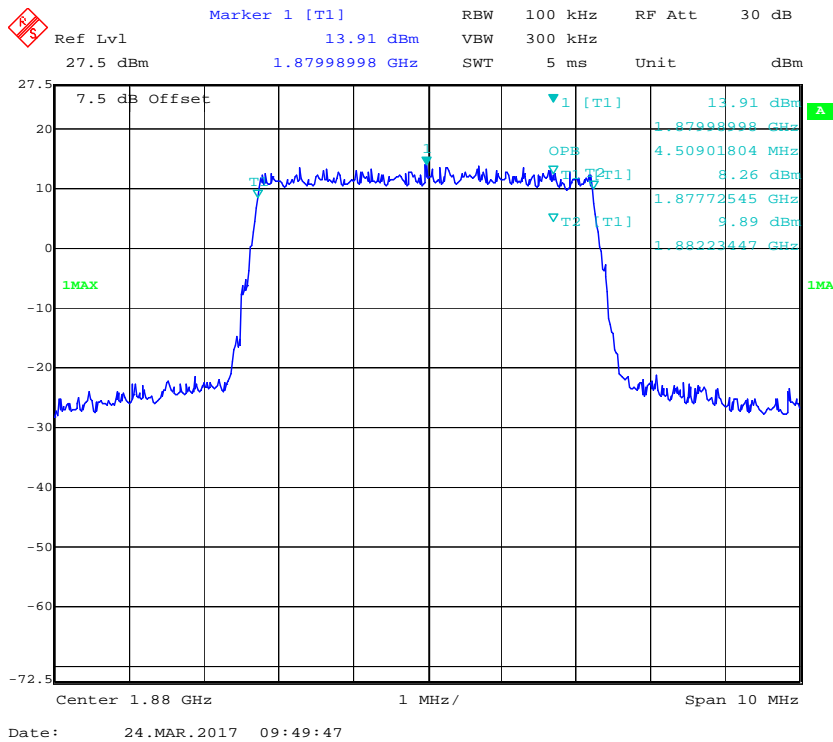

**QPSK (10.0 MHz) - 99% Occupied Bandwidth, Middle channel**

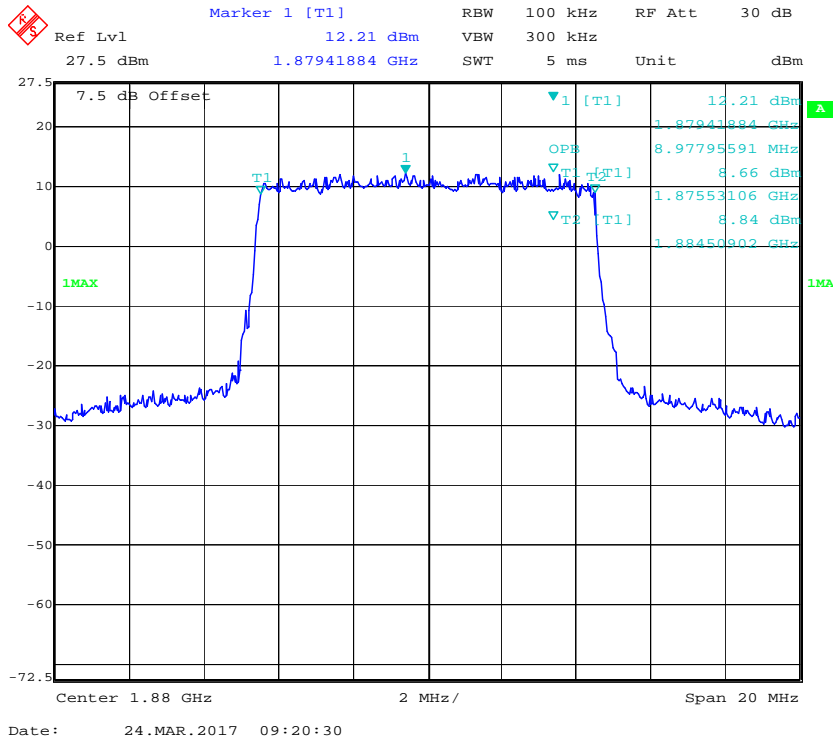

**16-QAM (10.0 MHz) - 99% Occupied Bandwidth, Middle channel**

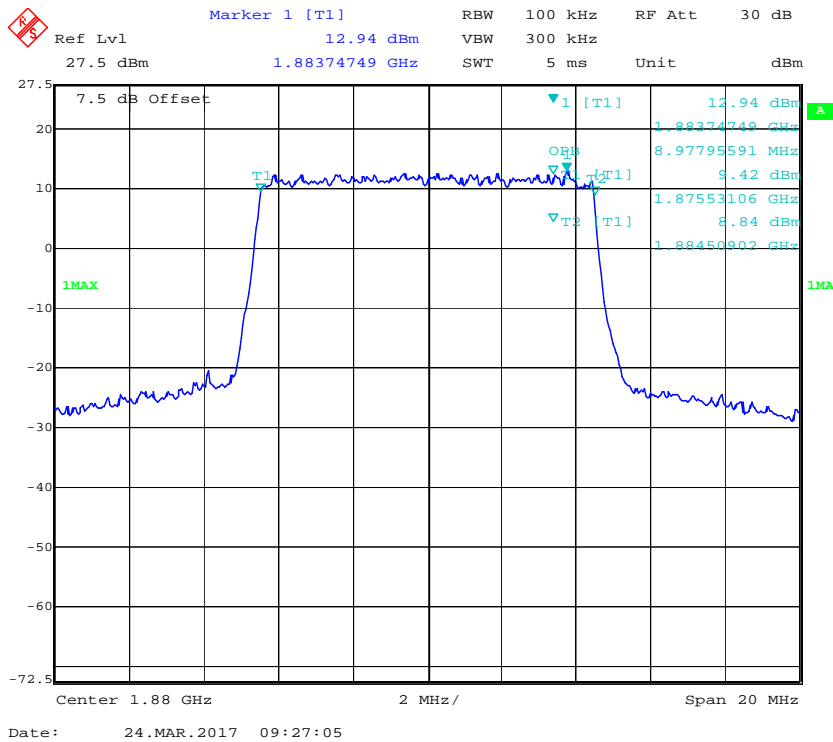

**QPSK (15.0 MHz) - 99% Occupied Bandwidth, Middle channel**

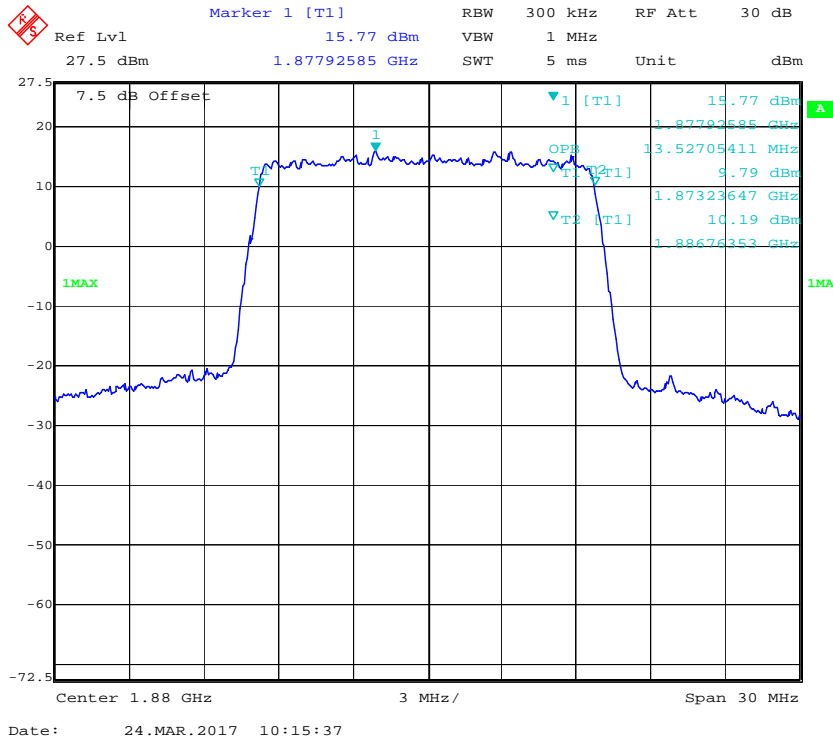

**16-QAM (15.0 MHz) - 99% Occupied Bandwidth, Middle channel**

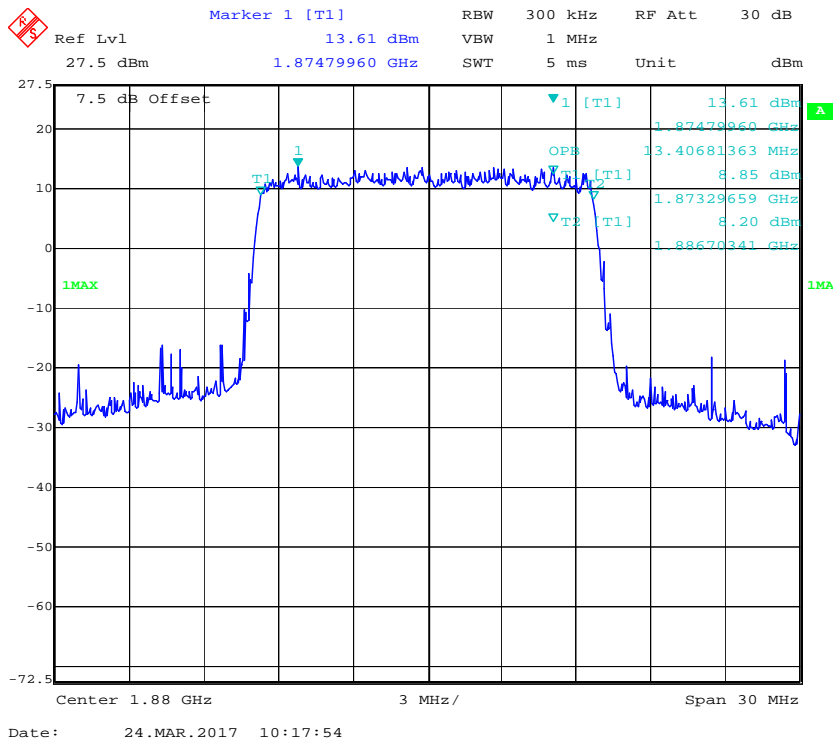

**QPSK (20.0 MHz) - 99% Occupied Bandwidth, Middle channel**

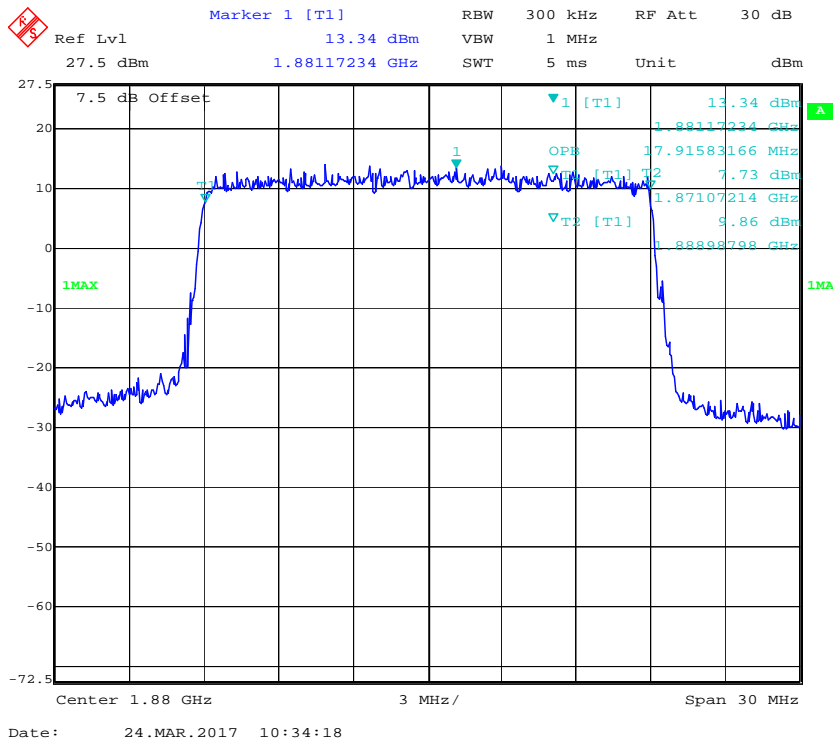

**16-QAM (20.0 MHz) - 99% Occupied Bandwidth, Middle channel**

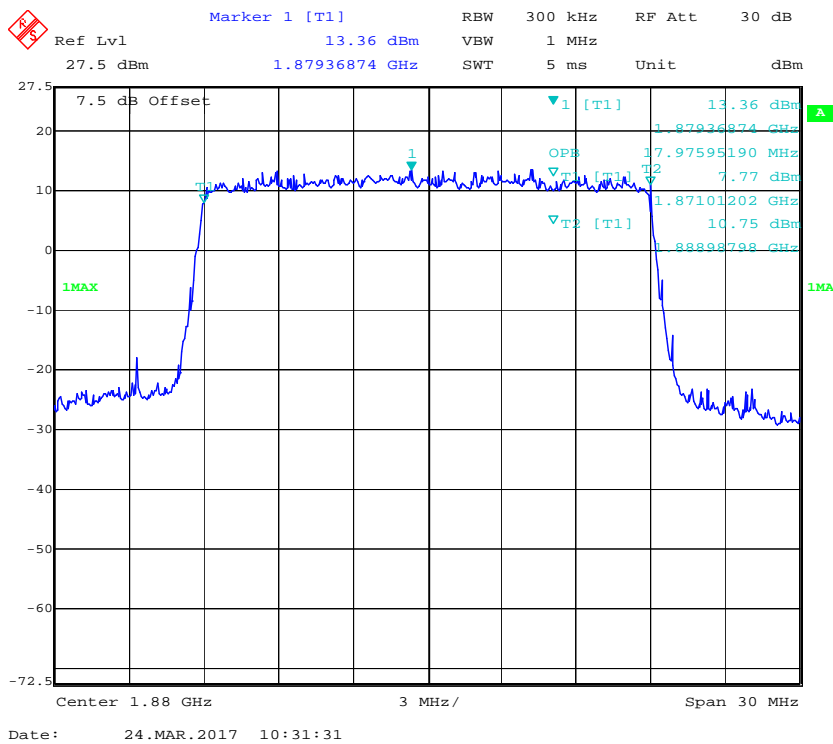



**QPSK (1.4 MHz) - 26 dB Emissions Bandwidth, Middle channel**

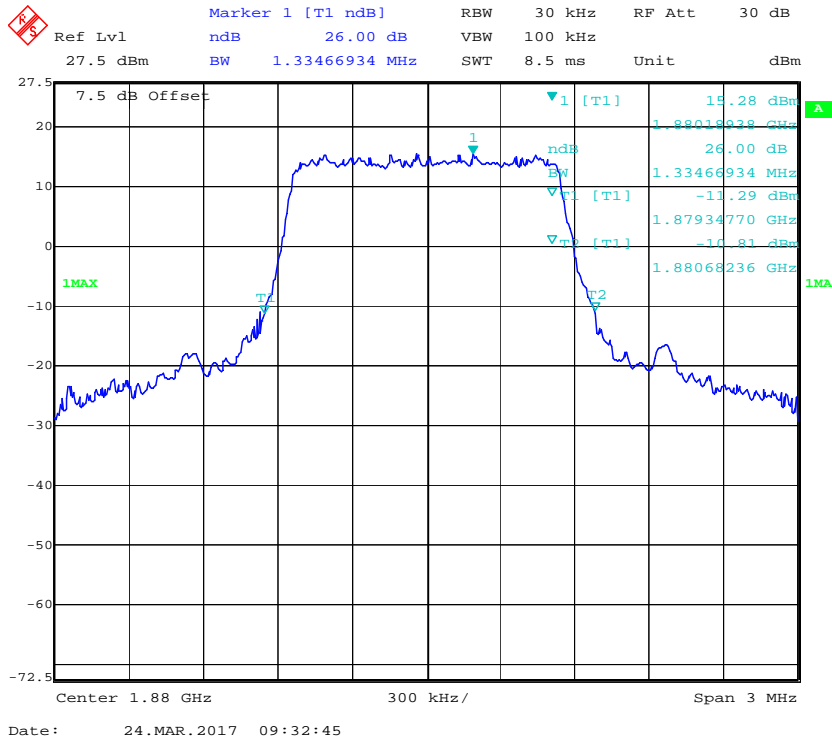

**16-QAM (1.4 MHz) - 26 dB Emissions Bandwidth, Middle channel**

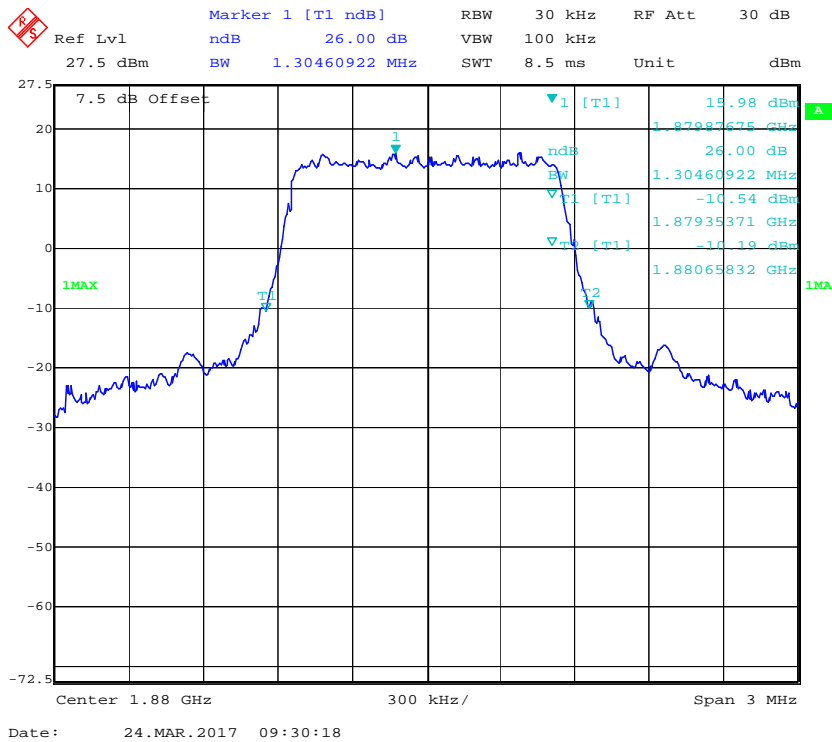

**QPSK (3.0 MHz) - 26 dB Emissions Bandwidth, Middle channel**

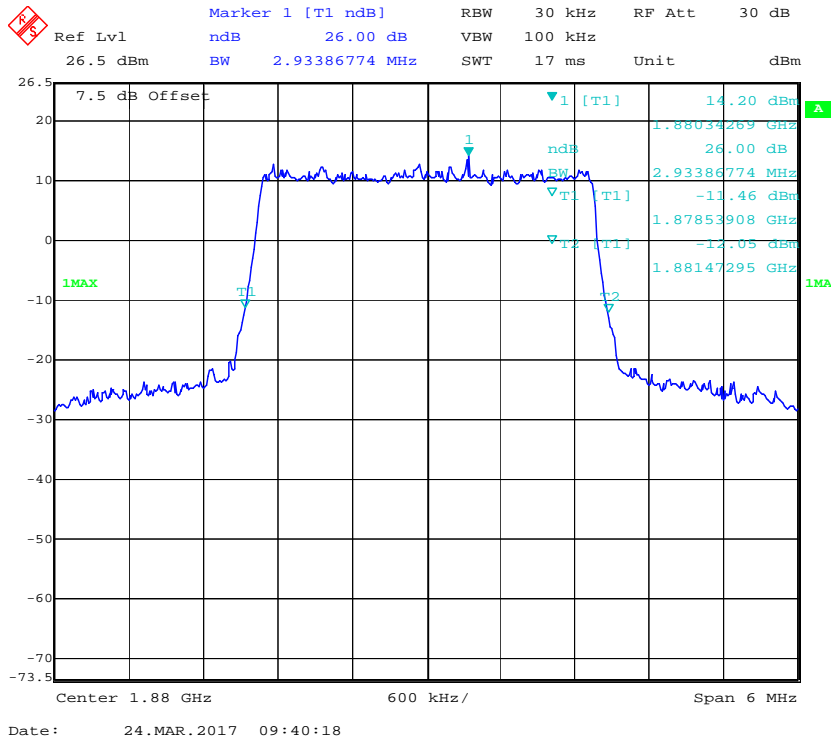

**16-QAM (3.0 MHz) - 26 dB Emissions Bandwidth, Middle channel**

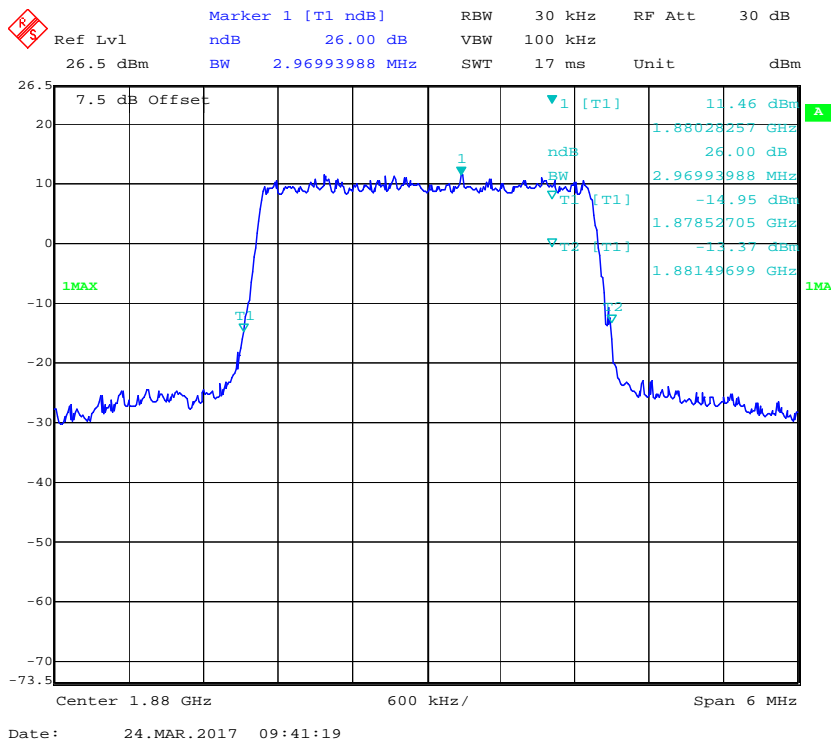

**QPSK (5.0 MHz) - 26 dB Emissions Bandwidth, Middle channel**

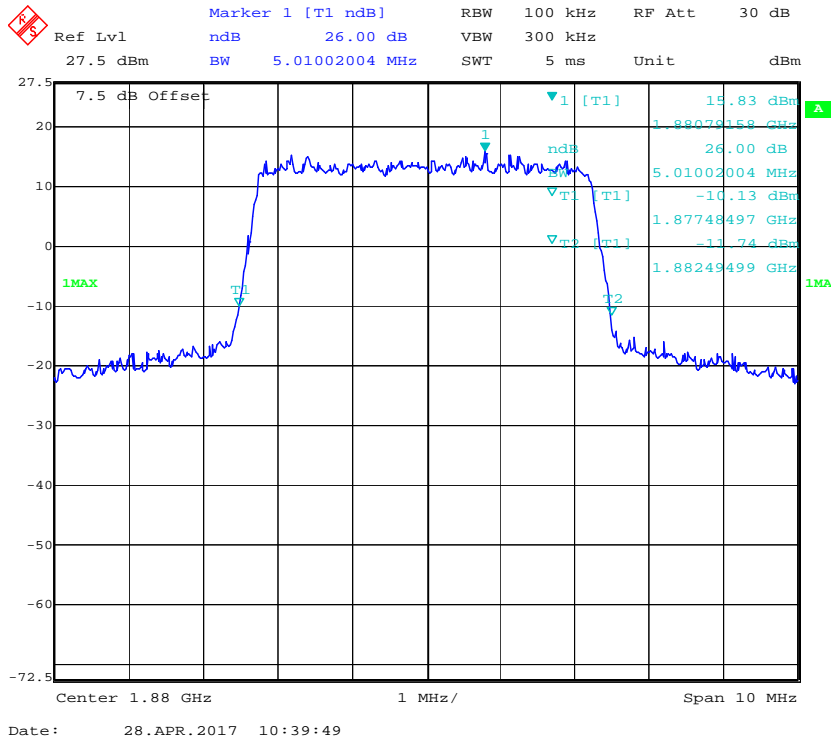

**16-QAM (5.0 MHz) - 26 dB Emissions Bandwidth, Middle channel**

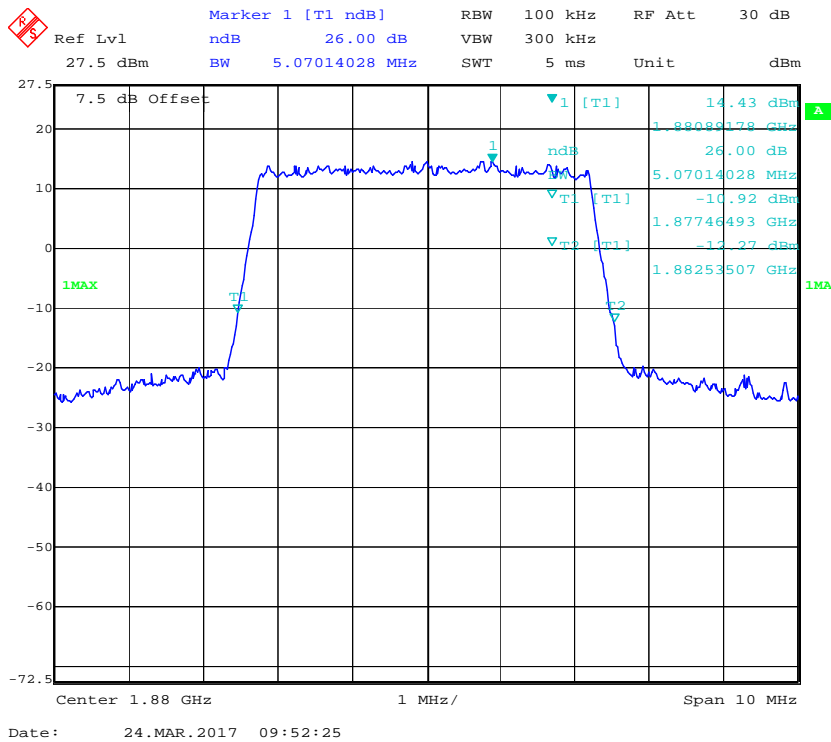

**QPSK (10.0 MHz) - 26 dB Emissions Bandwidth, Middle channel**

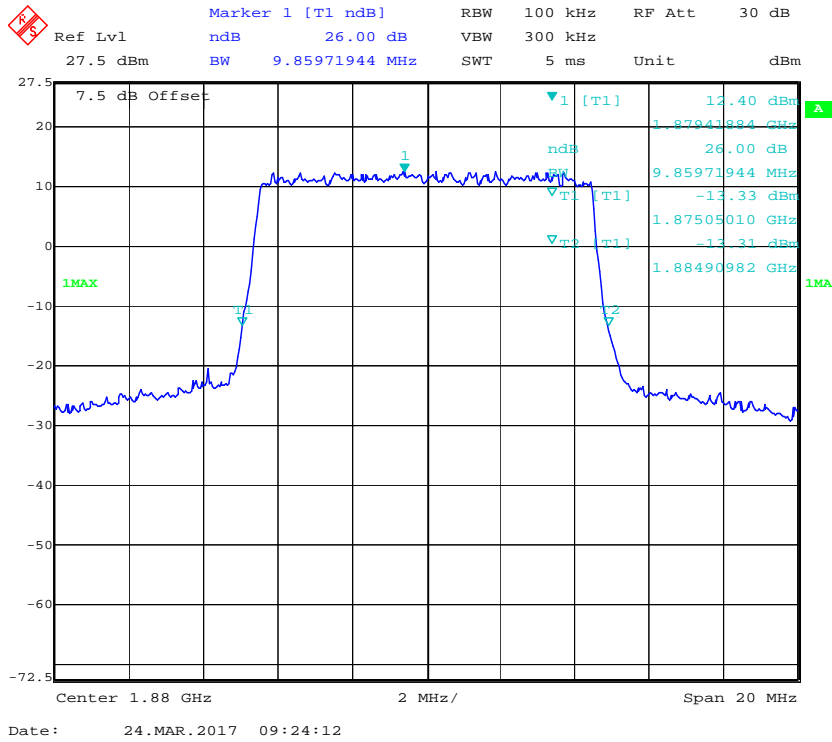

**16-QAM (10.0 MHz) - 26 dB Emissions Bandwidth, Middle channel**

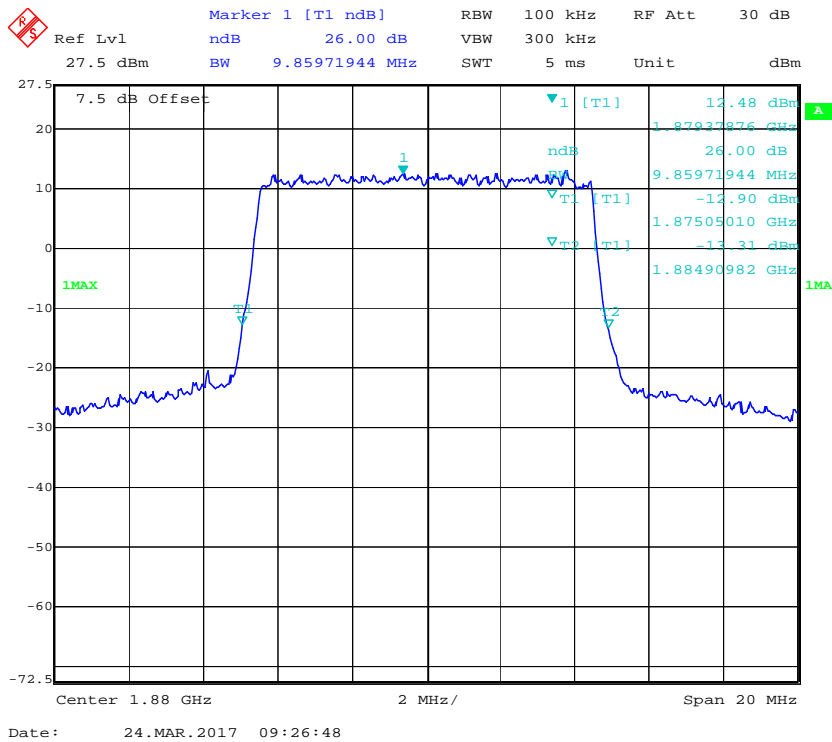

**QPSK (15.0 MHz) - 26 dB Emissions Bandwidth, Middle channel**

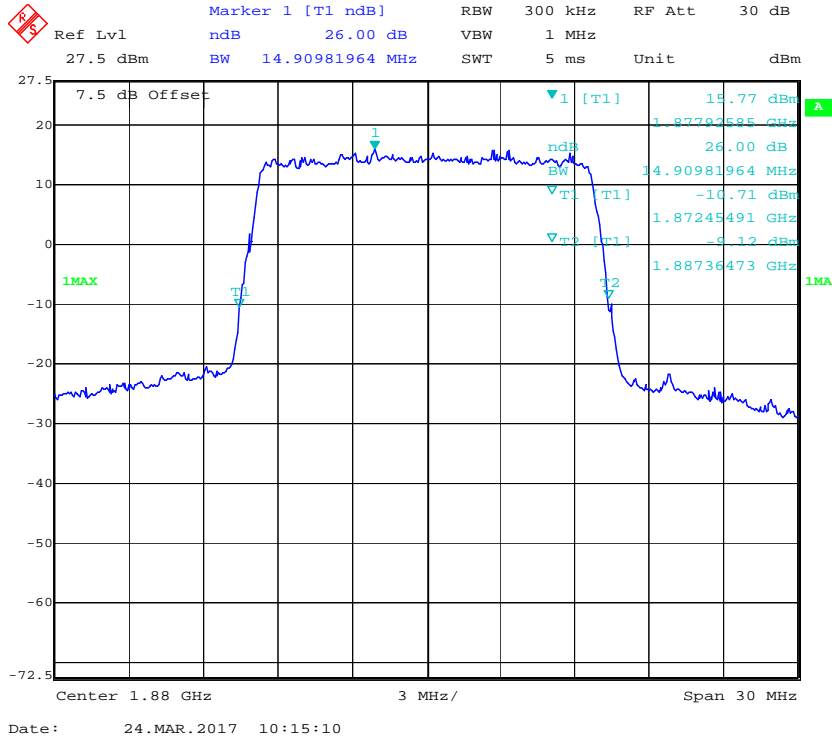

**16-QAM (15.0 MHz) - 26 dB Emissions Bandwidth, Middle channel**

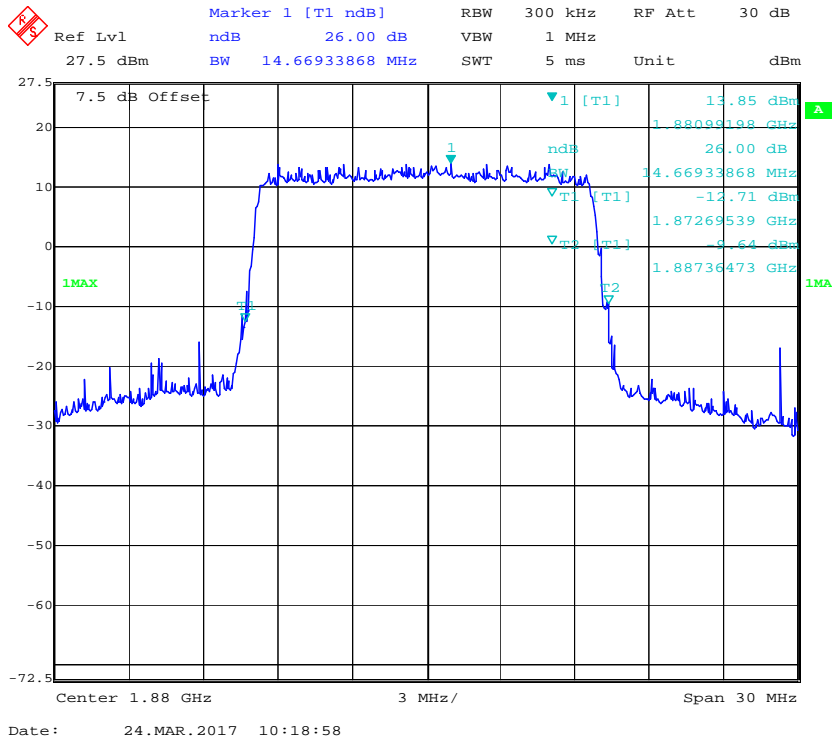

**QPSK (20.0 MHz) - 26 dB Emissions Bandwidth, Middle channel**

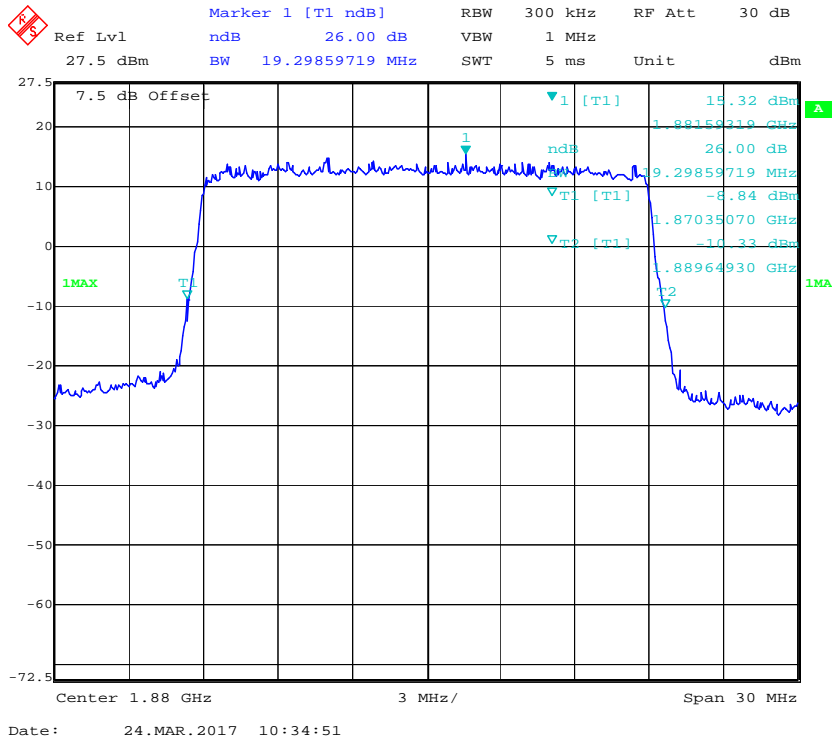

**16-QAM (20.0 MHz) - 26 dB Emissions Bandwidth, Middle channel**

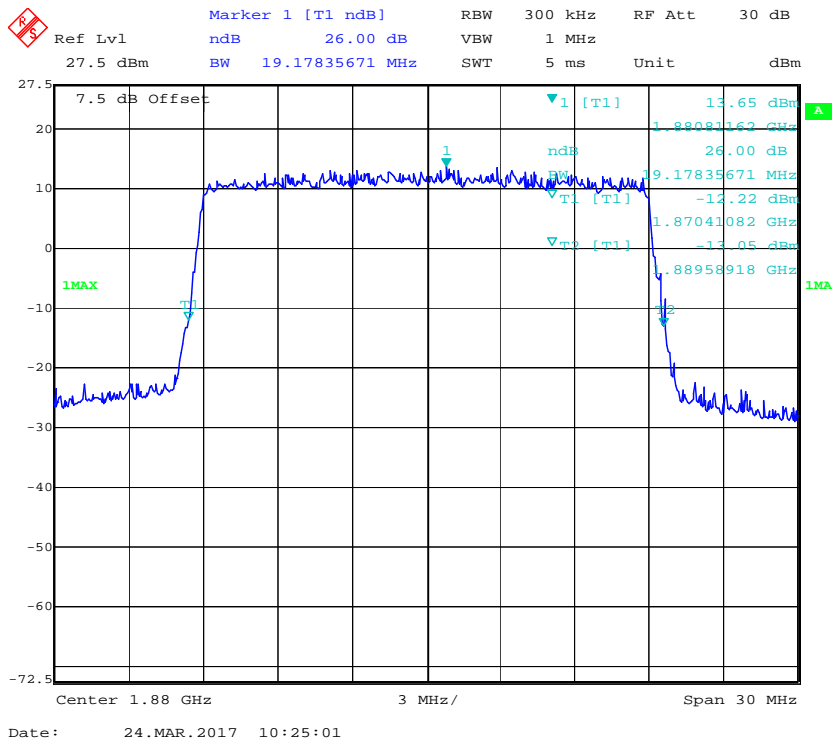

**LTE Band 4: (Middle Channel)**

<b>Bandwidth (MHz)</b>	<b>Modulation</b>	<b>99% Occupied Bandwidth (MHz)</b>	<b>26 dB Emission Bandwidth (MHz)</b>
1.4	QPSK	1.110	1.303
	16QAM	1.106	1.303
3.0	QPSK	2.705	2.958
	16QAM	2.693	2.922
5.0	QPSK	4.529	5.030
	16QAM	4.509	5.010
10.0	QPSK	8.938	9.820
	16QAM	8.938	9.659
15.0	QPSK	13.527	14.790
	16QAM	13.467	14.850
20.0	QPSK	17.876	19.399
	16QAM	17.876	19.399

**QPSK (1.4 MHz) - 99% Occupied Bandwidth, Middle channel**

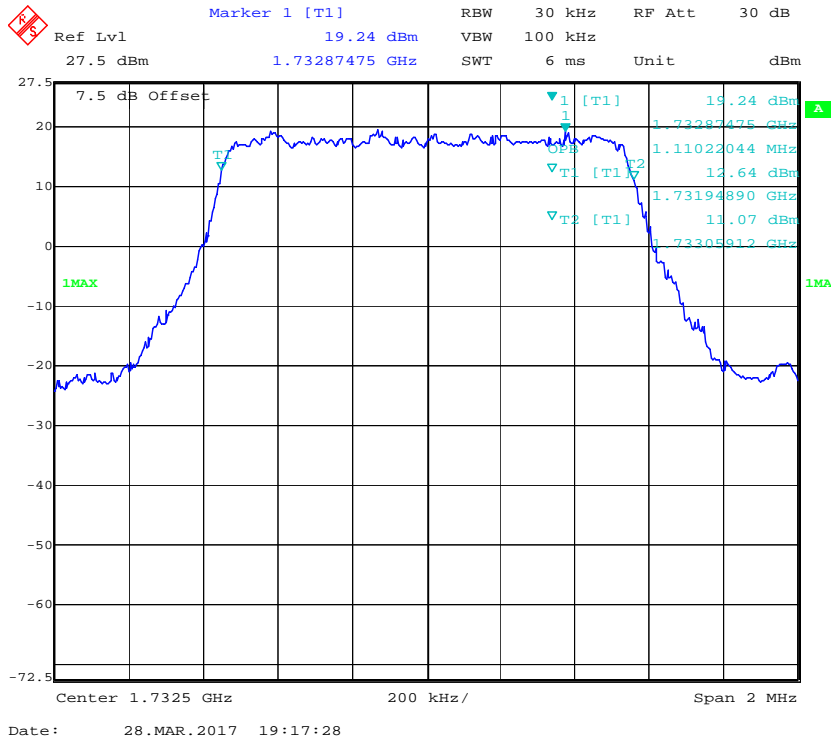

**16-QAM (1.4 MHz) - 99% Occupied Bandwidth, Middle channel**

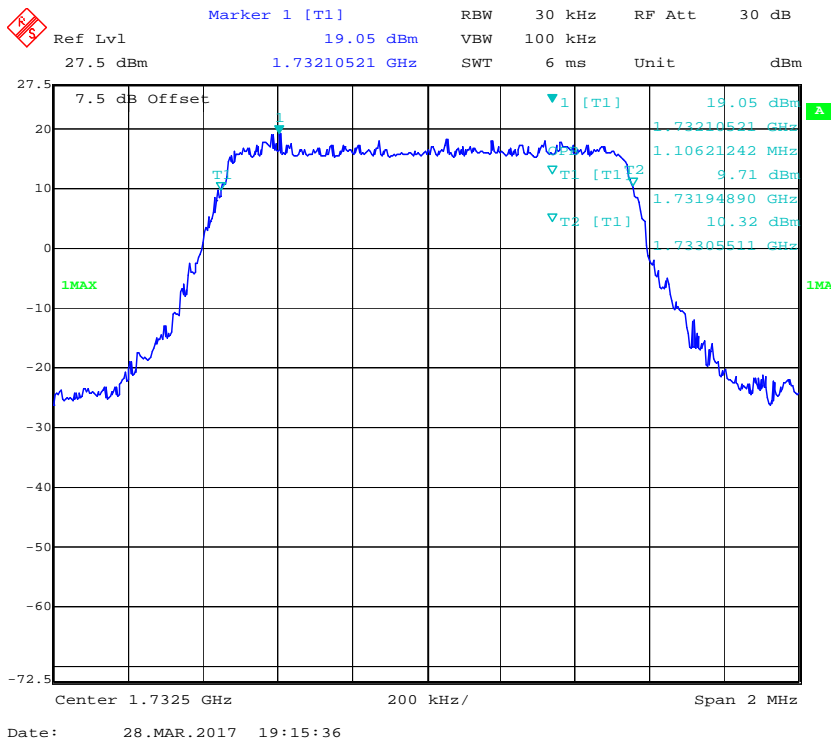



**QPSK (3.0 MHz) - 99% Occupied Bandwidth, Middle channel**

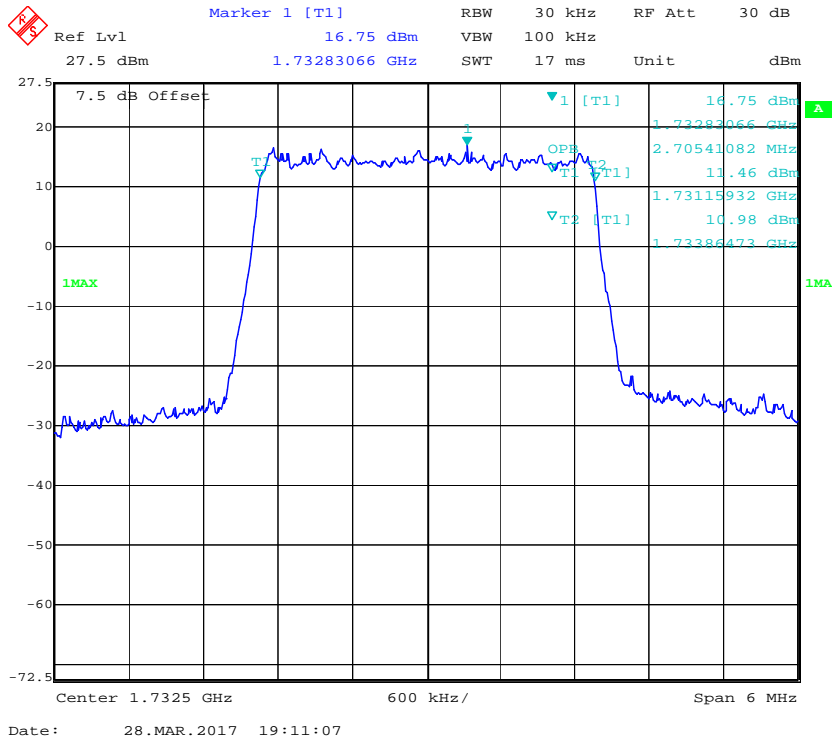

**16-QAM (3.0 MHz) - 99% Occupied Bandwidth, Middle channel**

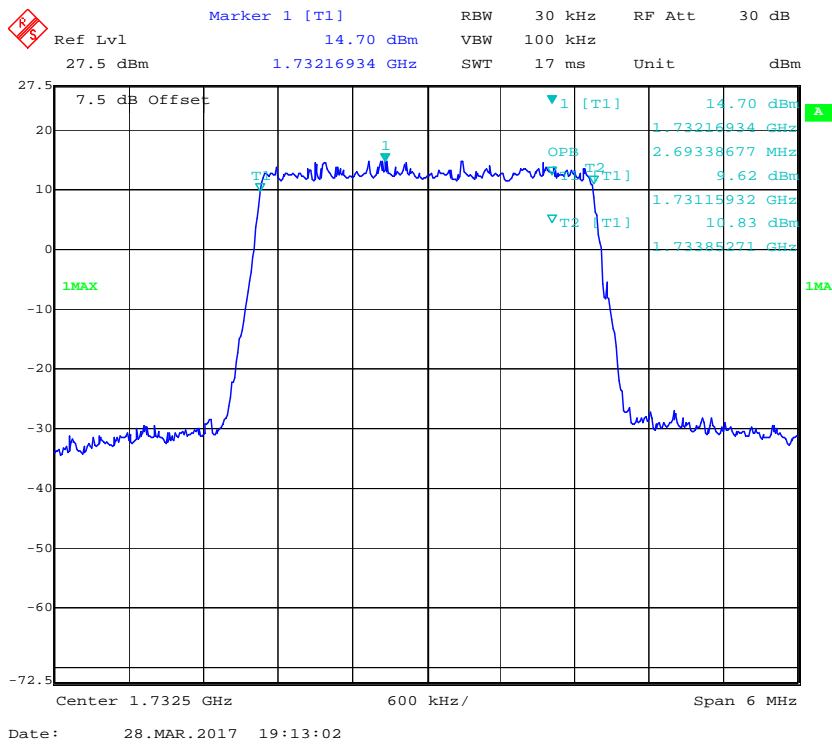

**QPSK (5.0 MHz) - 99% Occupied Bandwidth, Middle channel**

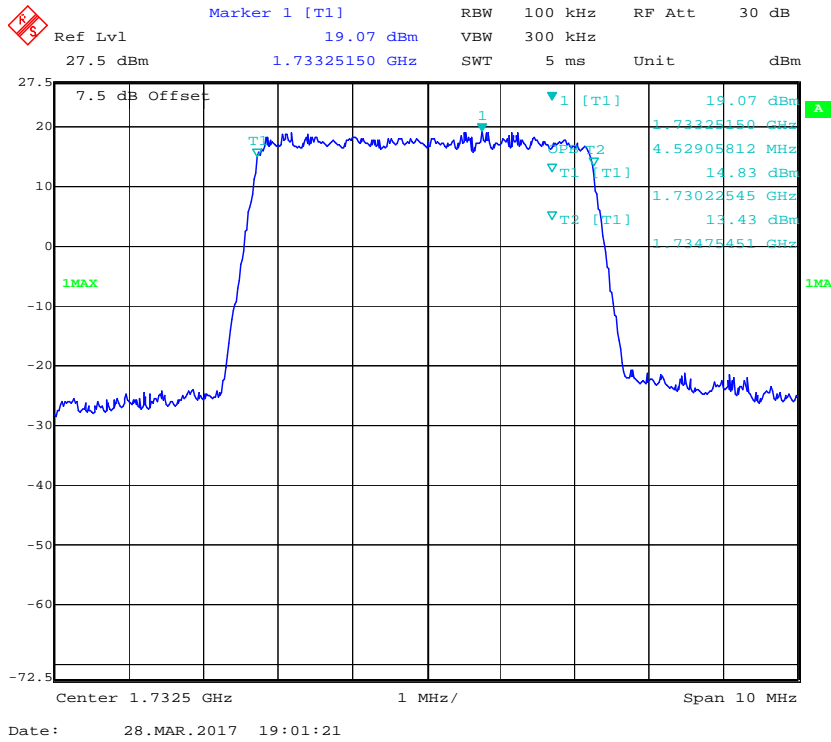

**16-QAM (5.0 MHz) - 99% Occupied Bandwidth, Middle channel**

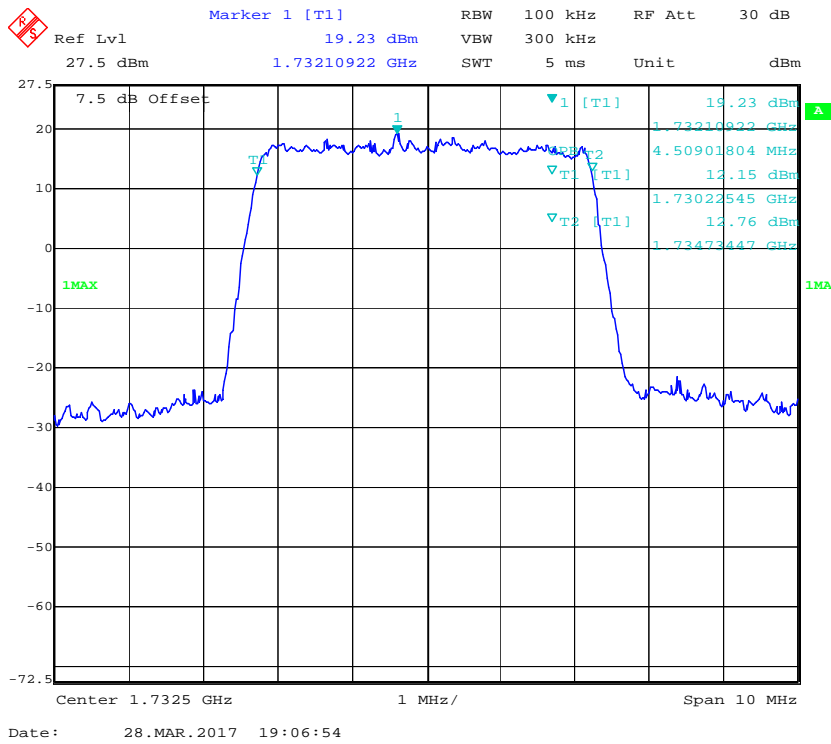

**QPSK (10.0 MHz) - 99% Occupied Bandwidth, Middle channel**

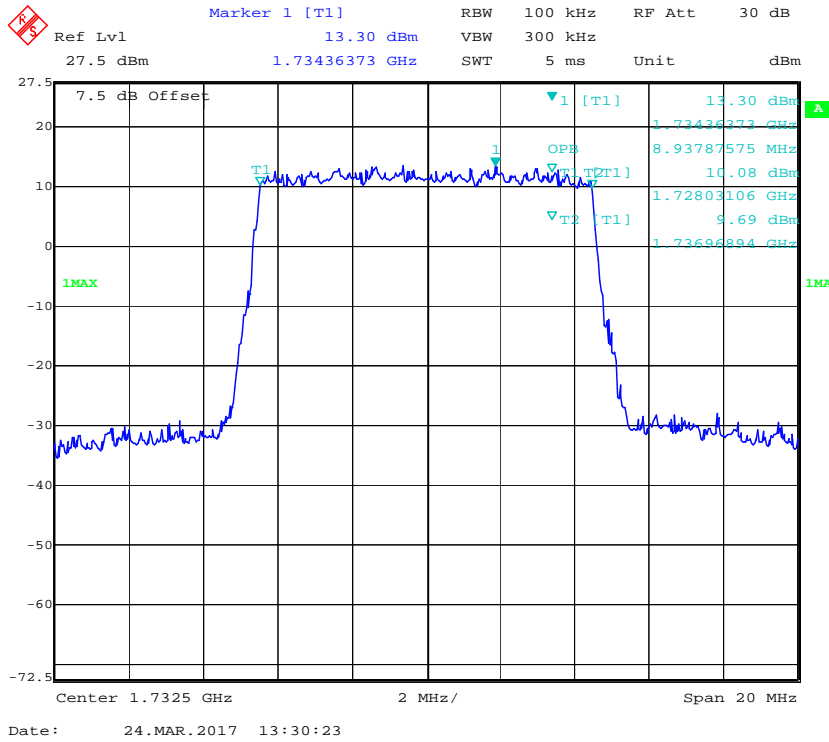

**16-QAM (10.0 MHz) - 99% Occupied Bandwidth, Middle channel**

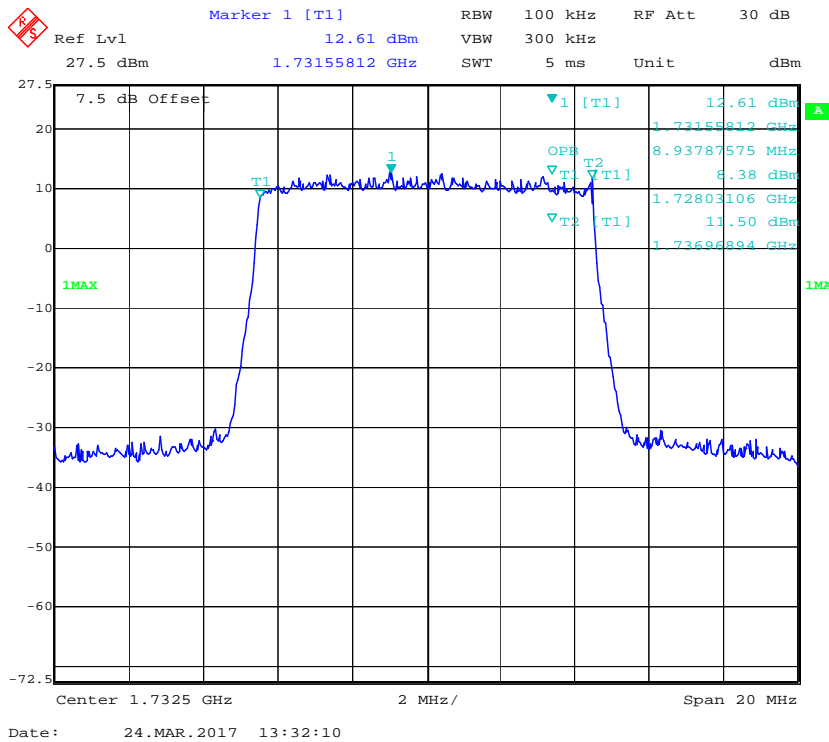

**QPSK (15.0 MHz) - 99% Occupied Bandwidth, Middle channel**

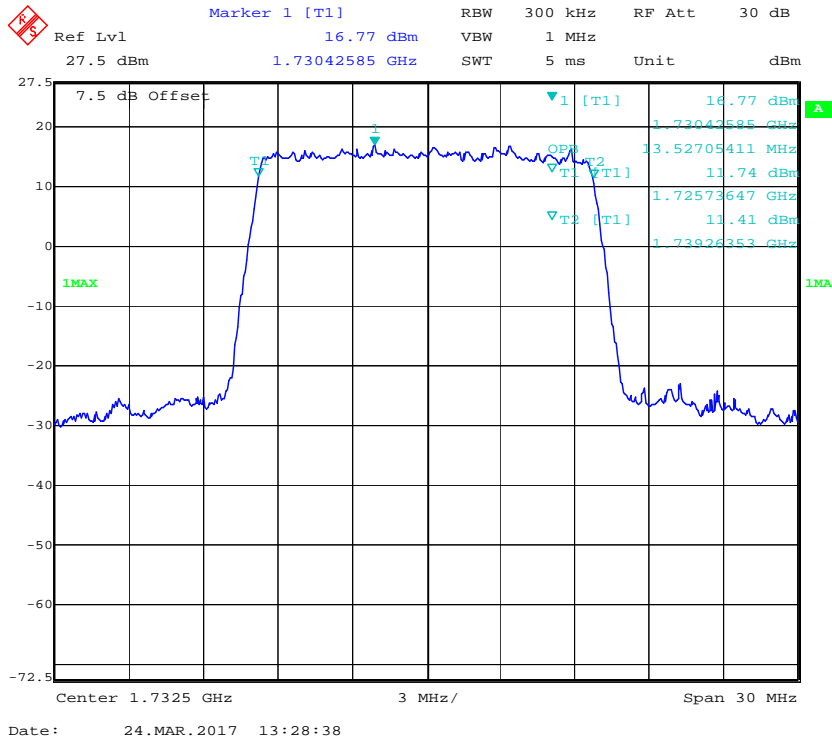

**16-QAM (15.0 MHz) - 99% Occupied Bandwidth, Middle channel**

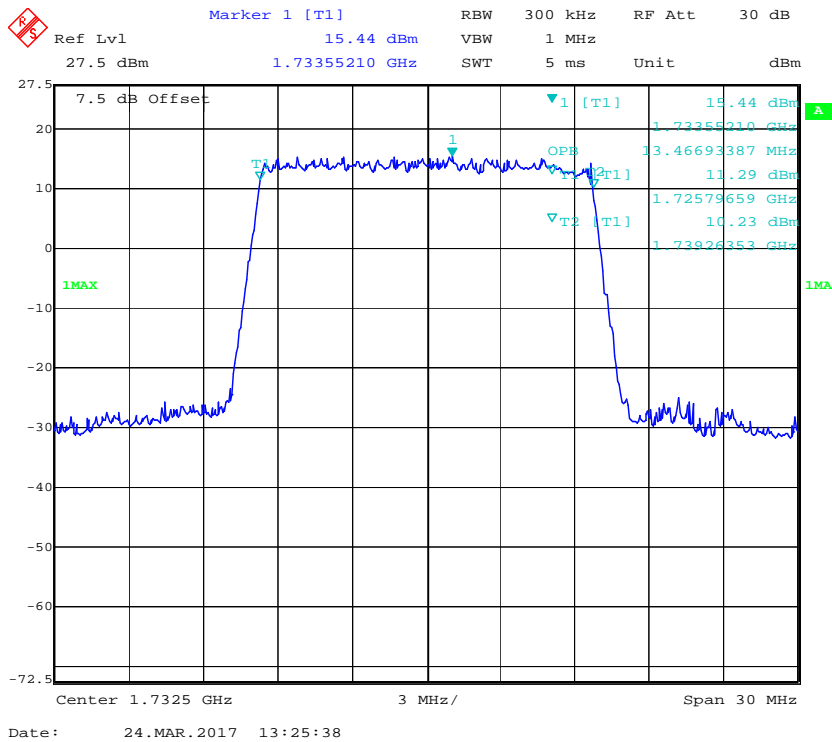

**QPSK (20.0 MHz) - 99% Occupied Bandwidth, Middle channel**

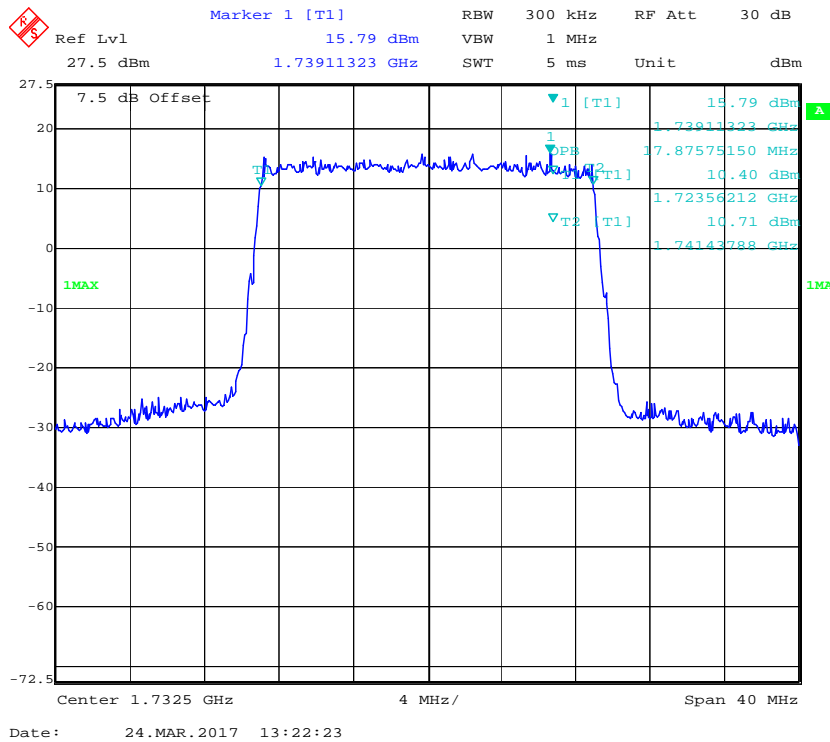

**16-QAM (20.0 MHz) - 99% Occupied Bandwidth, Middle channel**

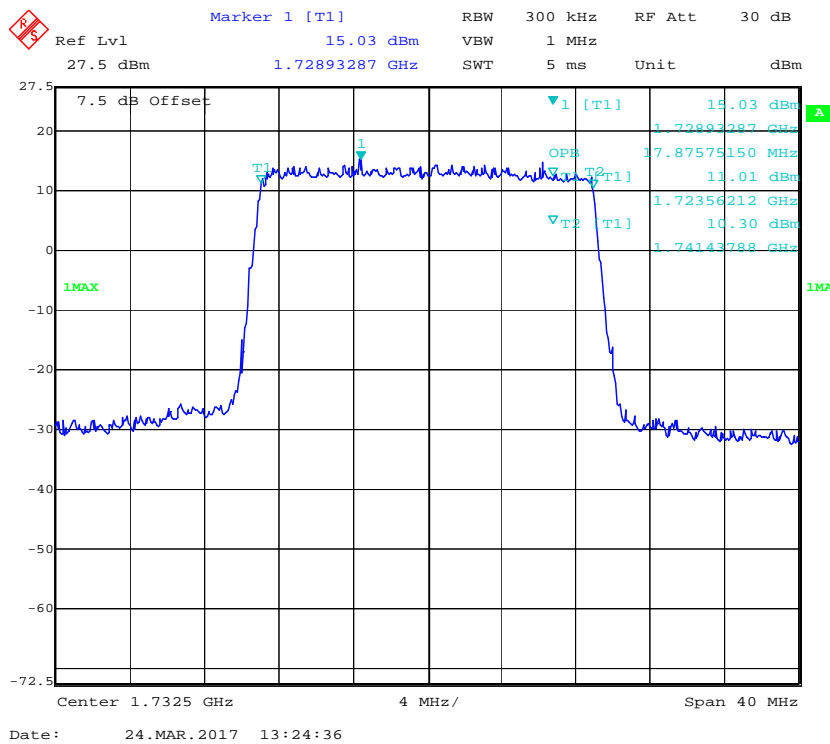

**QPSK (1.4 MHz) - 26 dB Emissions Bandwidth, Middle channel**

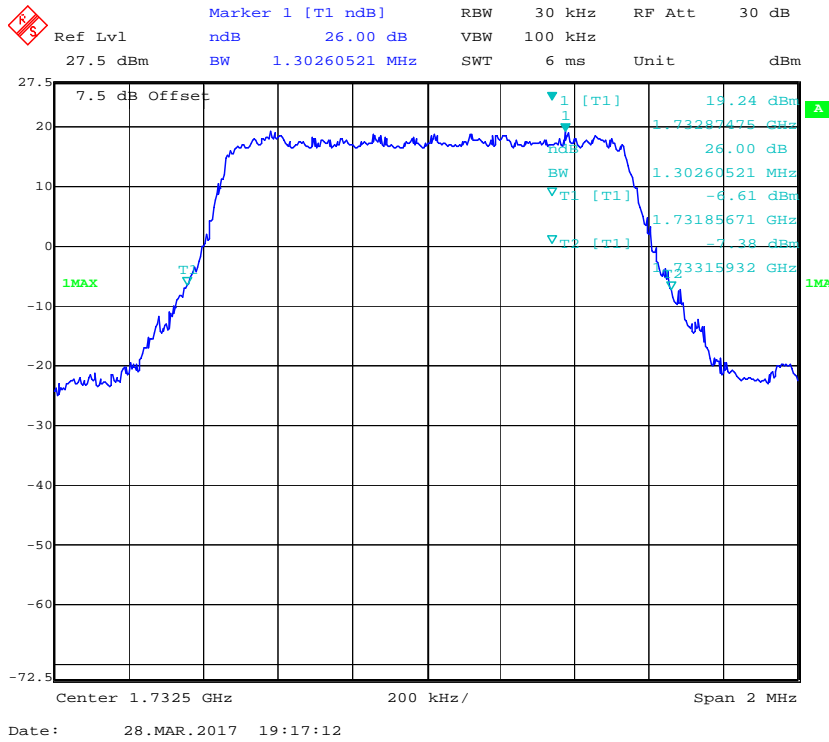

**16-QAM (1.4 MHz) - 26 dB Emissions Bandwidth, Middle channel**

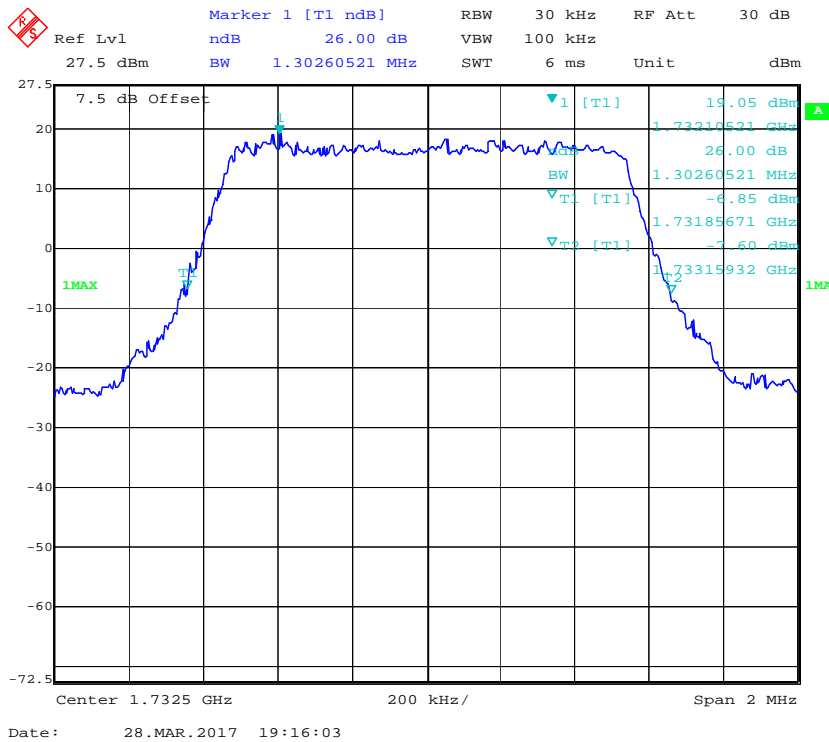

**QPSK (3.0 MHz) - 26 dB Emissions Bandwidth, Middle channel**

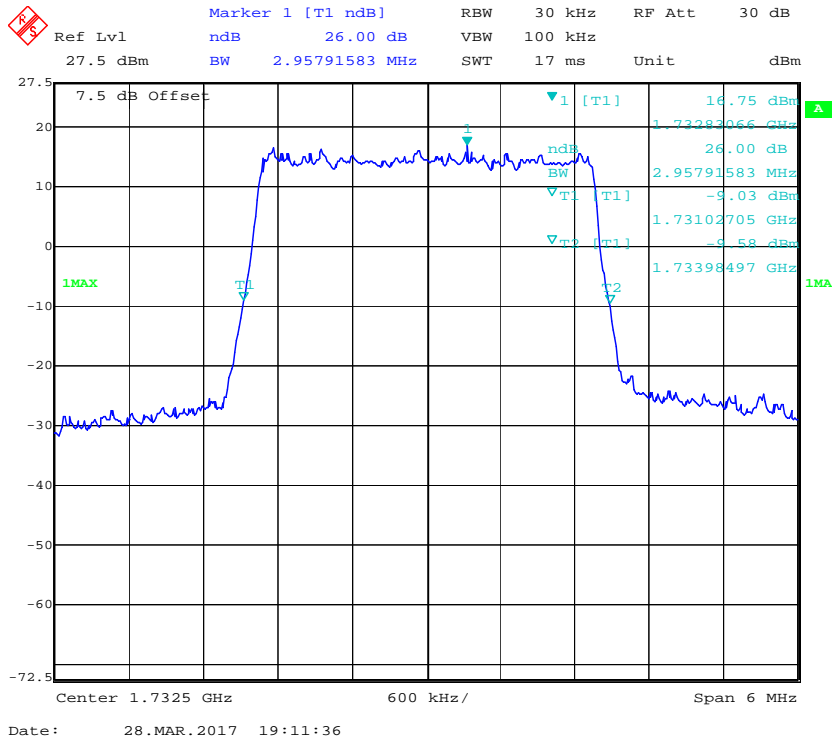

**16-QAM (3.0 MHz) - 26 dB Emissions Bandwidth, Middle channel**

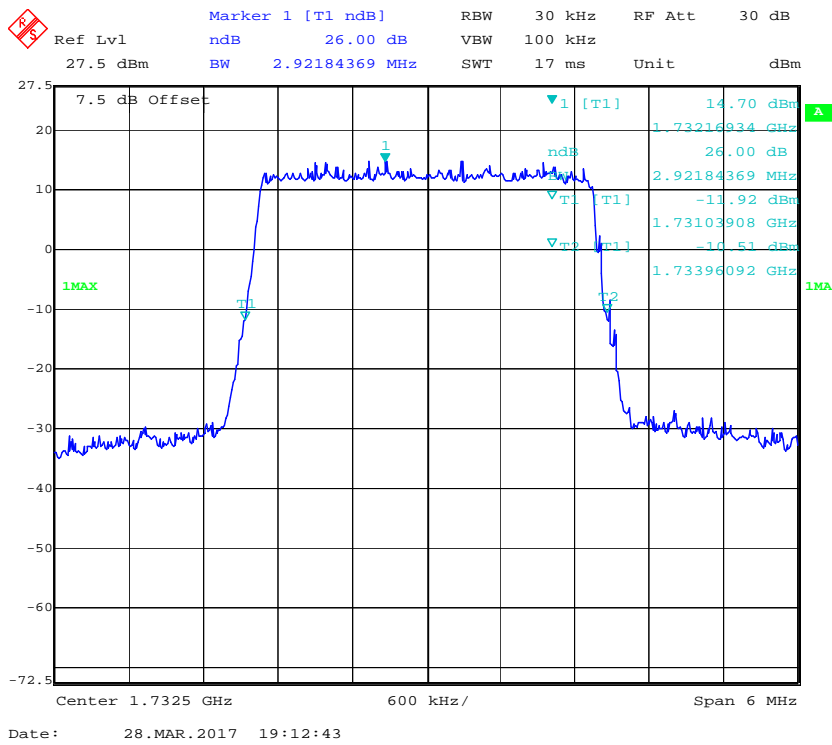

**QPSK (5.0 MHz) - 26 dB Emissions Bandwidth, Middle channel**

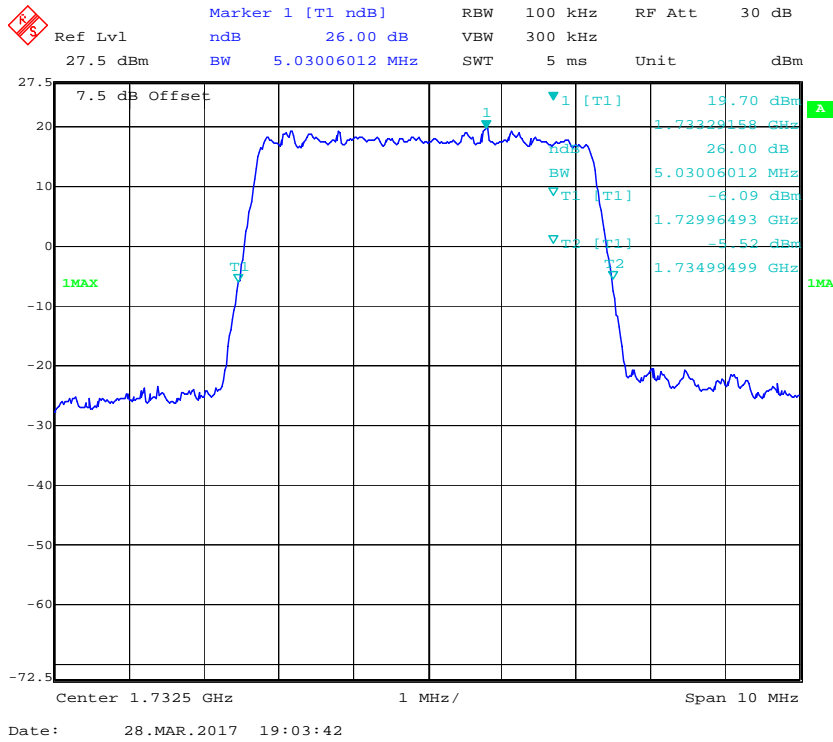

**16-QAM (5.0 MHz) - 26 dB Emissions Bandwidth, Middle channel**

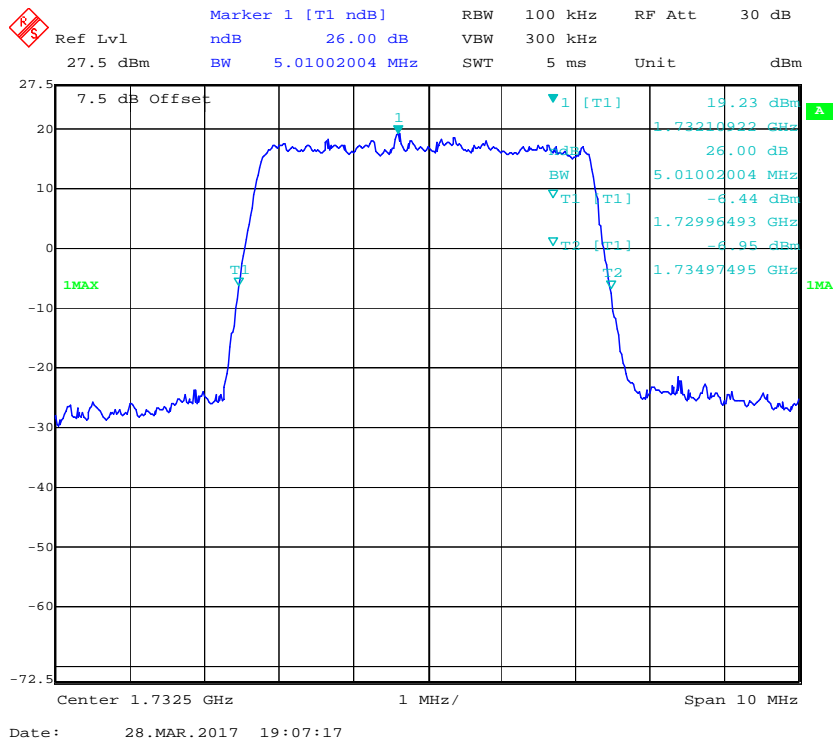



**QPSK (10.0 MHz) - 26 dB Emissions Bandwidth, Middle channel**

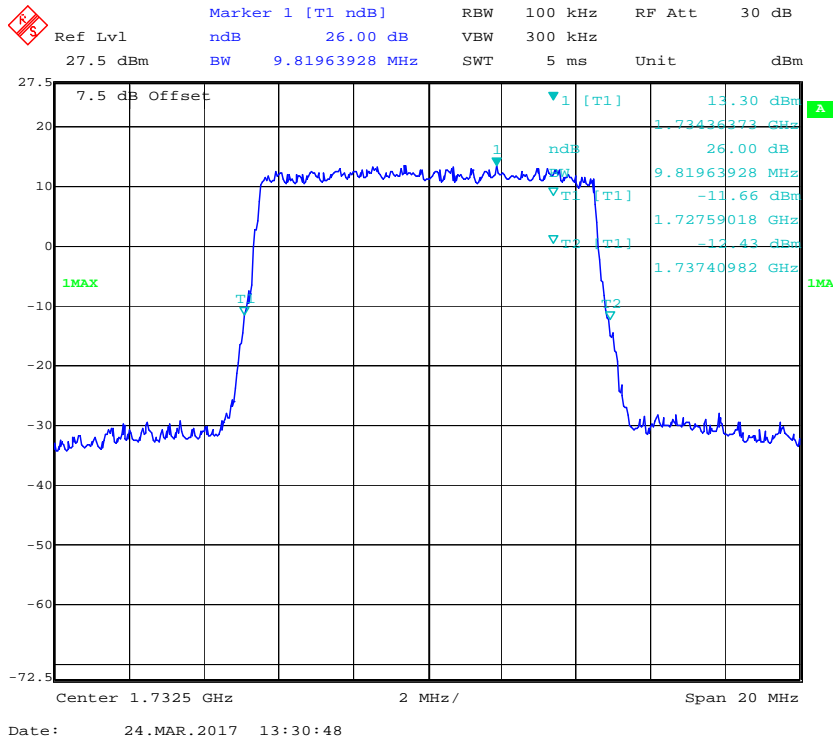

**16-QAM (10.0 MHz) - 26 dB Emissions Bandwidth, Middle channel**

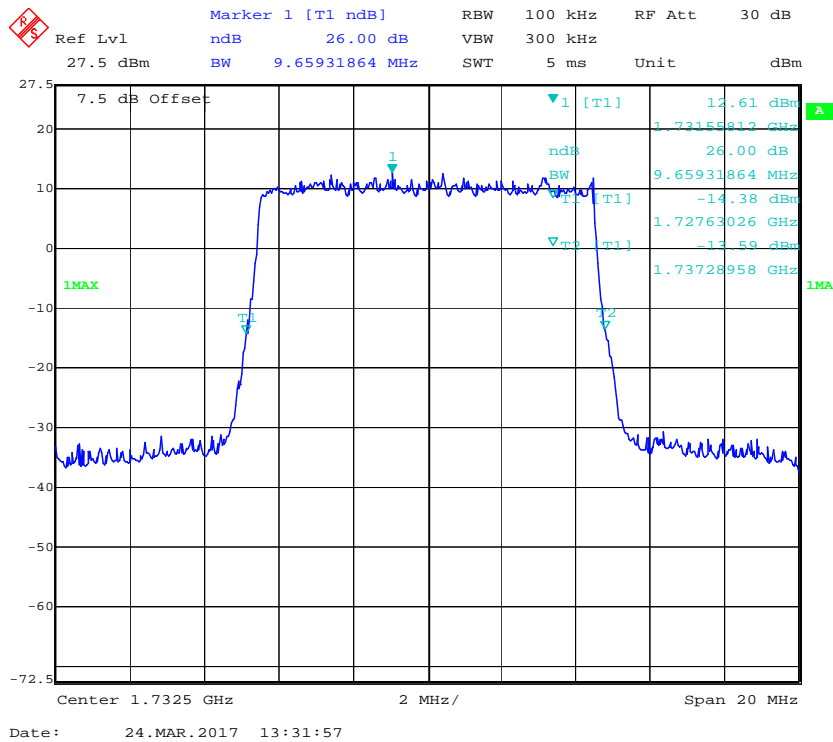

**QPSK (15.0 MHz) - 26 dB Emissions Bandwidth, Middle channel**

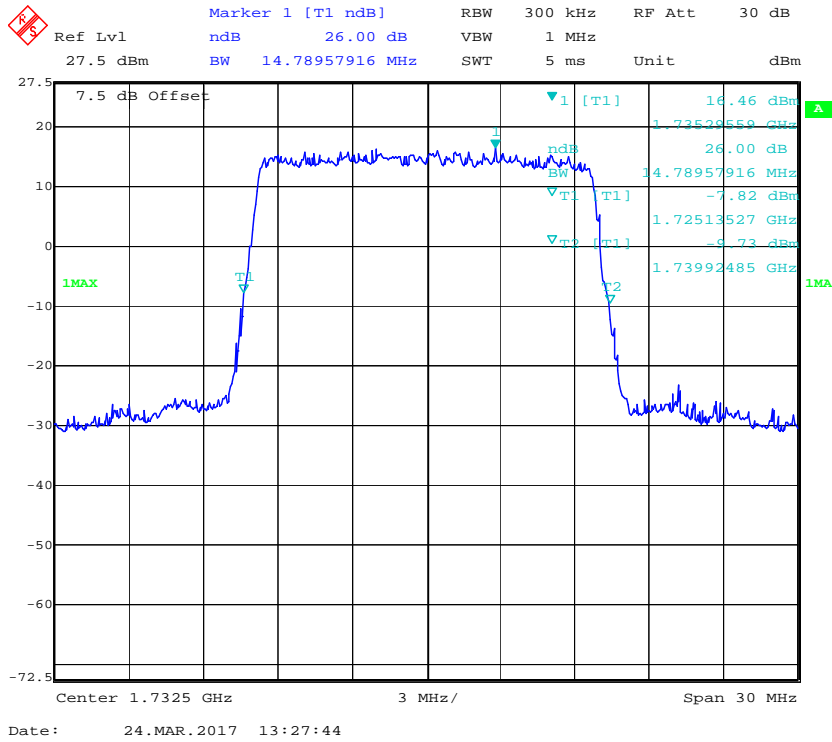

**16-QAM (15.0 MHz) - 26 dB Emissions Bandwidth, Middle channel**

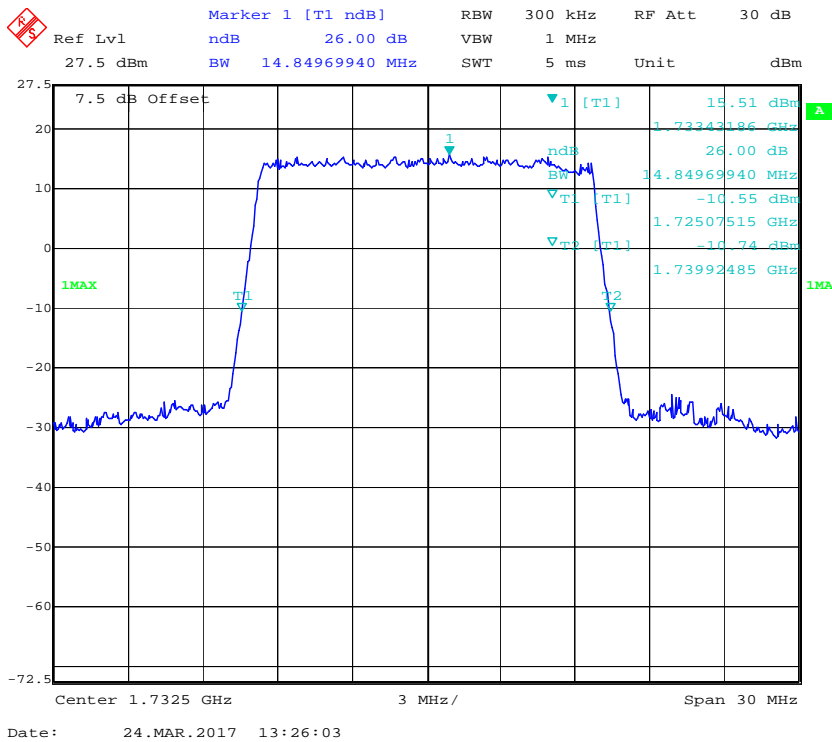

**QPSK (20.0 MHz) - 26 dB Emissions Bandwidth, Middle channel**

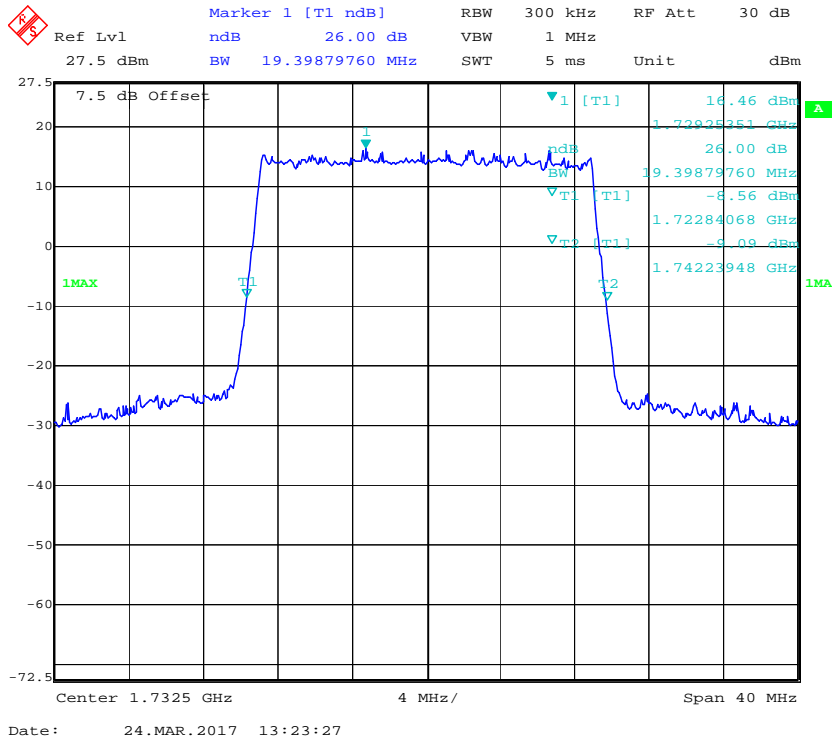

**16-QAM (20.0 MHz) - 26 dB Emissions Bandwidth, Middle channel**

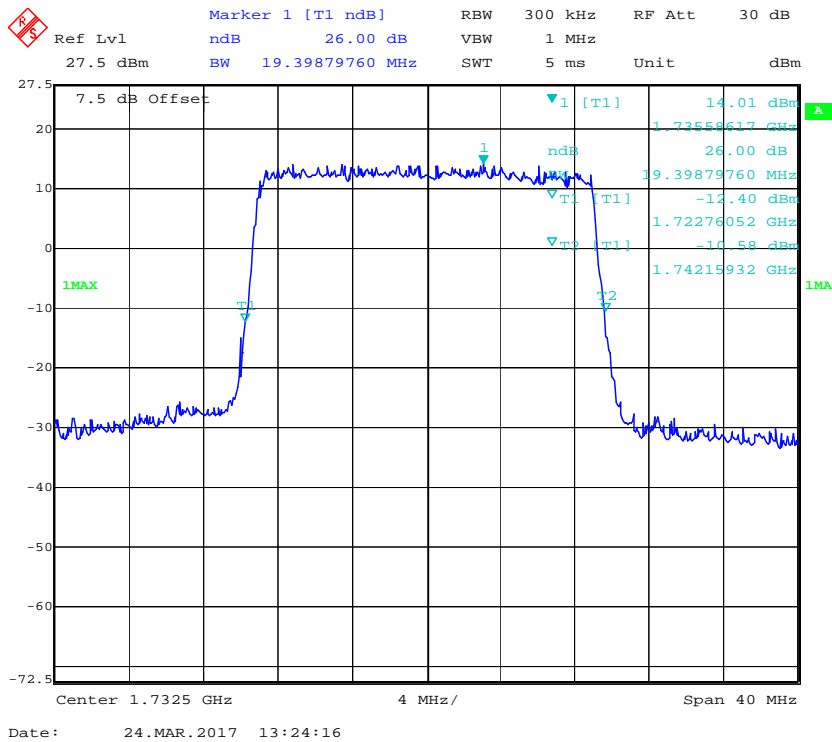

**LTE Band 5: (Middle Channel)**

<b>Bandwidth (MHz)</b>	<b>Modulation</b>	<b>99% Occupied Bandwidth (MHz)</b>	<b>26 dB Emission Bandwidth (MHz)</b>
1.4	QPSK	1.100	1.311
	16QAM	1.112	1.293
3.0	QPSK	2.693	2.934
	16QAM	2.693	2.958
5.0	QPSK	4.509	5.010
	16QAM	4.509	5.010
10.0	QPSK	8.978	9.820
	16QAM	8.938	9.699

**QPSK (1.4 MHz) - 99% Occupied Bandwidth, Middle channel**

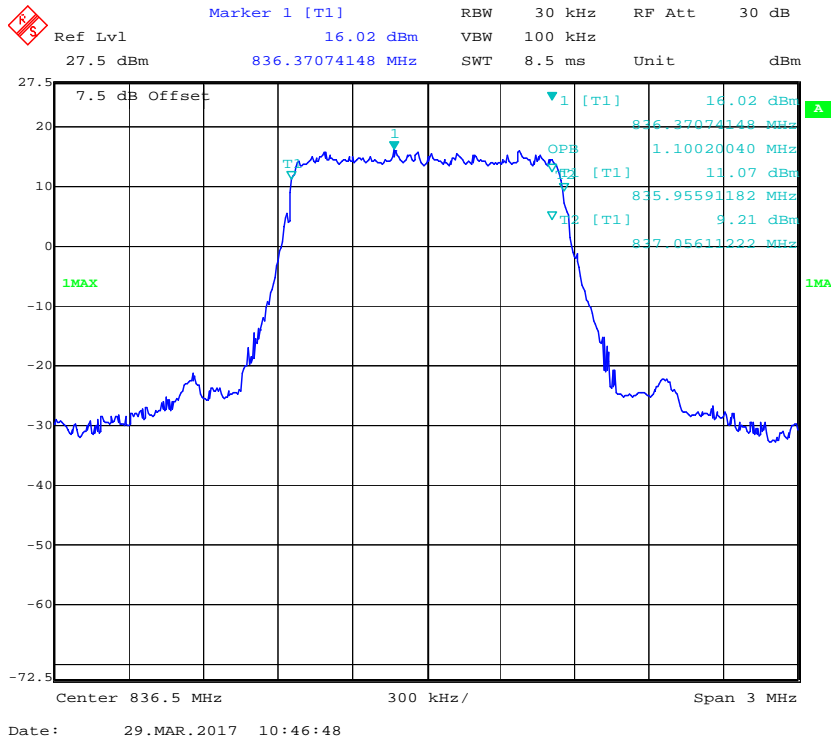

**16-QAM (1.4 MHz) - 99% Occupied Bandwidth, Middle channel**

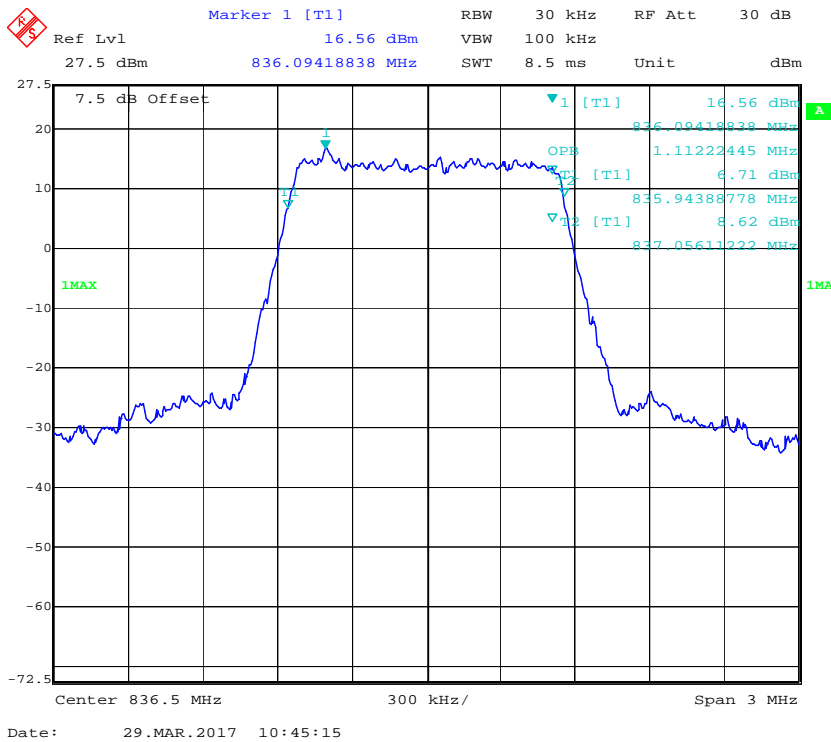

**QPSK (3.0 MHz) - 99% Occupied Bandwidth, Middle channel**

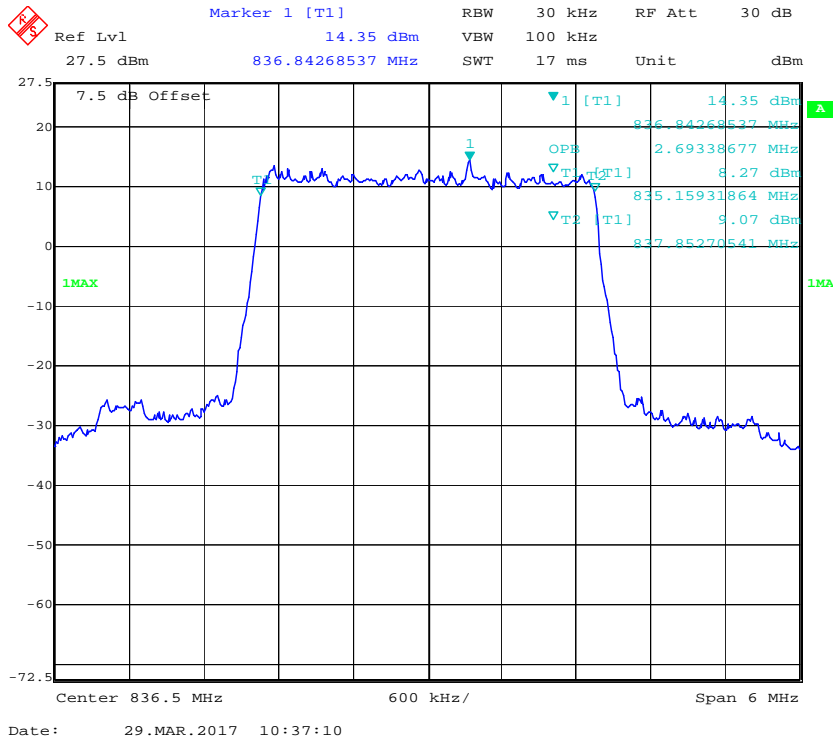

**16-QAM (3.0 MHz) - 99% Occupied Bandwidth, Middle channel**

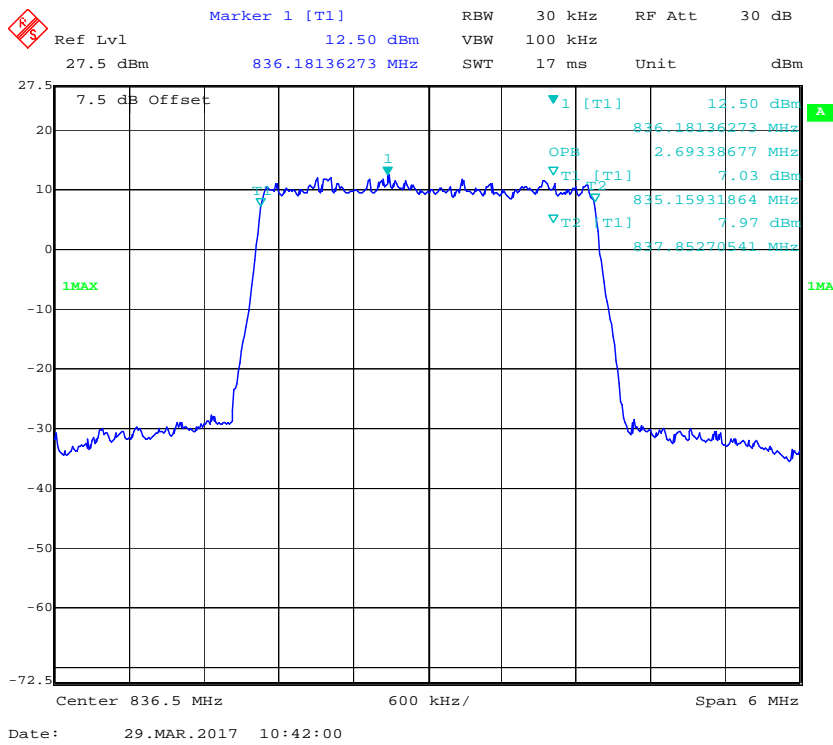

**QPSK (5.0 MHz) - 99% Occupied Bandwidth, Middle channel**

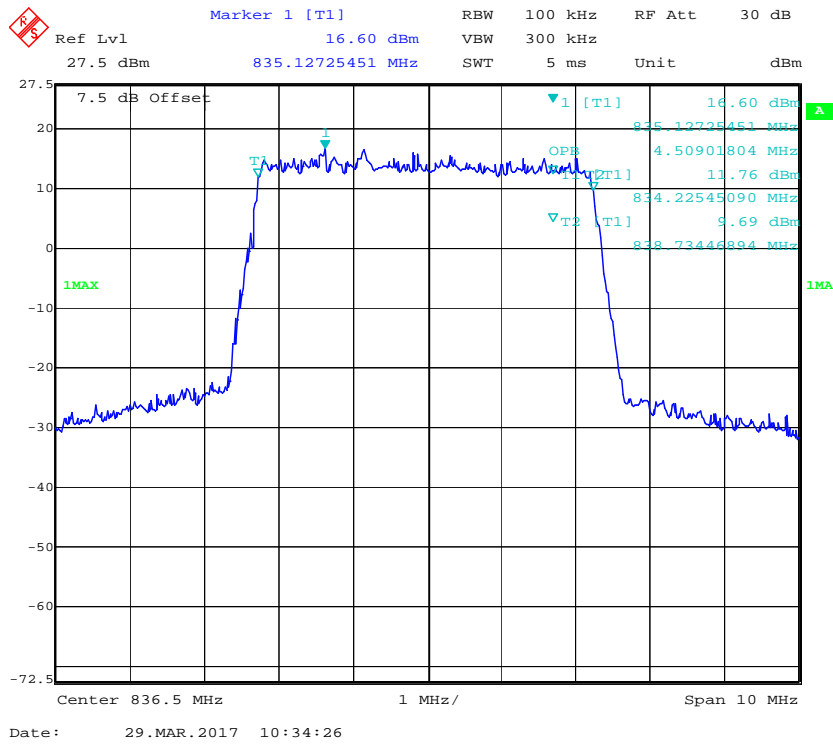

**16-QAM (5.0 MHz) - 99% Occupied Bandwidth, Middle channel**

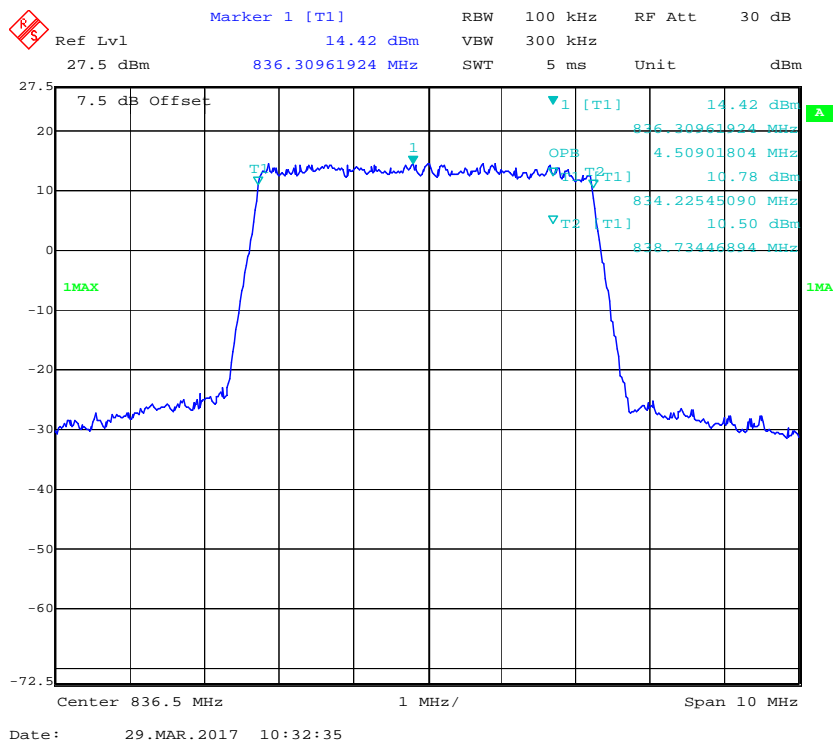

**QPSK (10.0 MHz) - 99% Occupied Bandwidth, Middle channel**

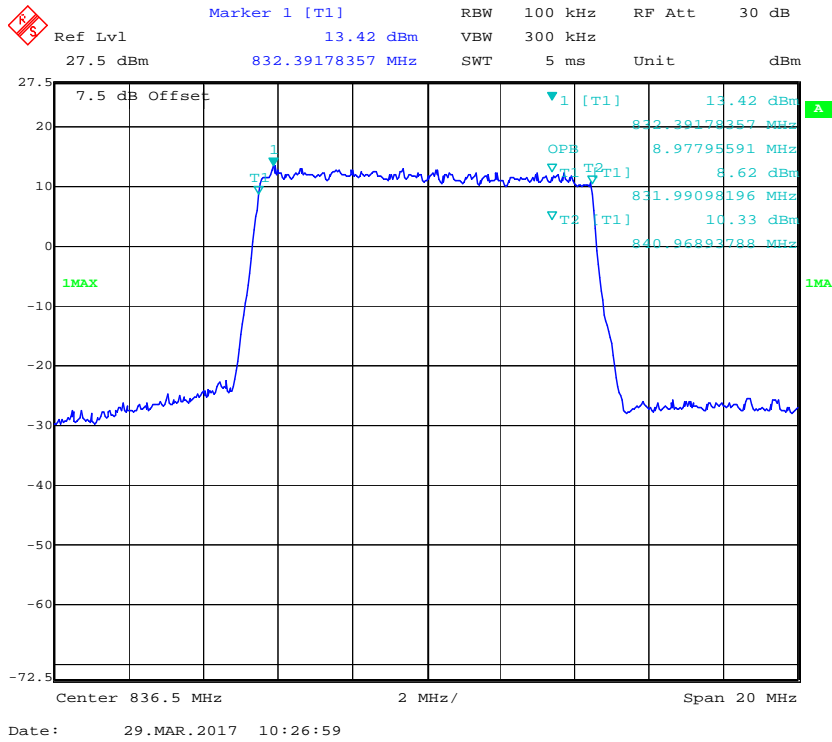

**16-QAM (10.0 MHz) - 99% Occupied Bandwidth, Middle channel**

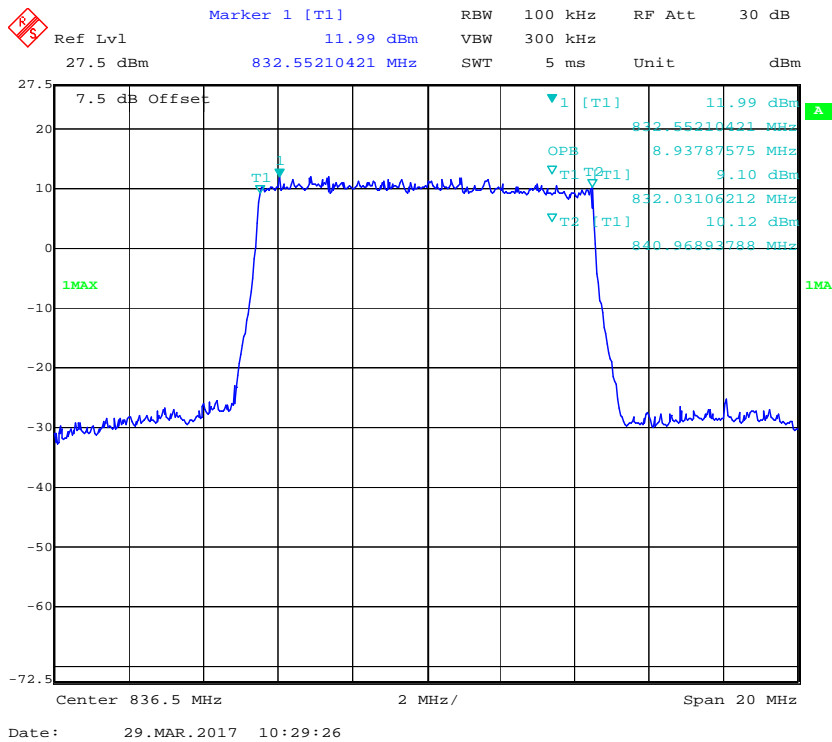



**QPSK (1.4 MHz) - 26 dB Emissions Bandwidth, Middle channel**



**16-QAM (1.4 MHz) - 26 dB Emissions Bandwidth, Middle channel**

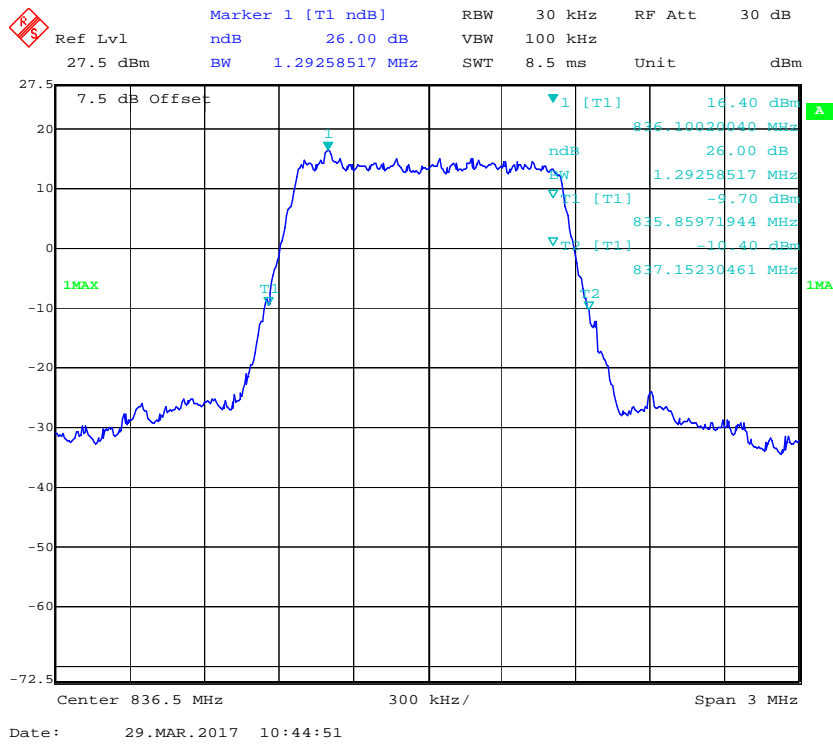

**QPSK (3.0 MHz) - 26 dB Emissions Bandwidth, Middle channel**

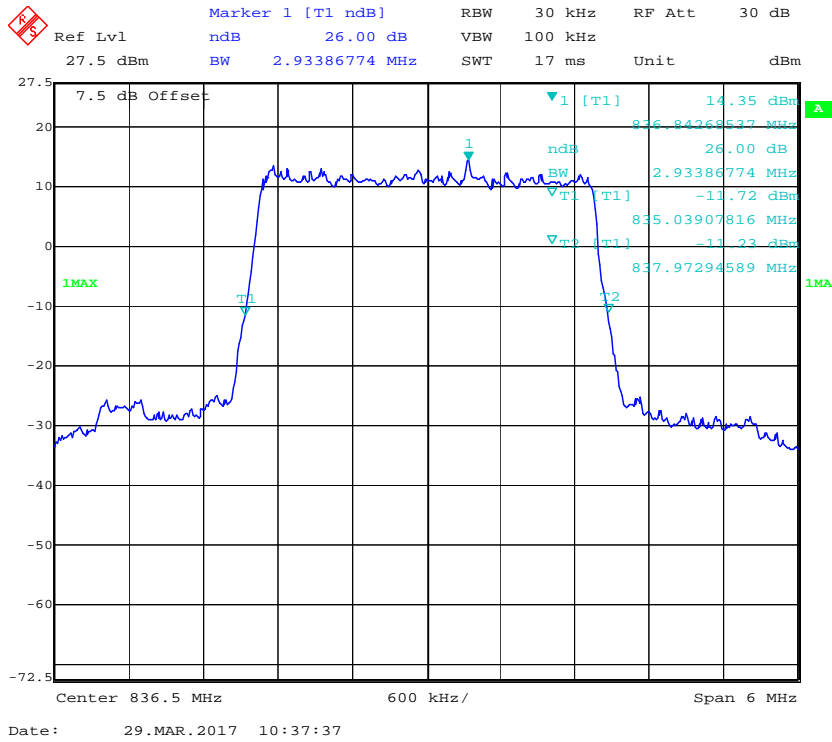

**16-QAM (3.0 MHz) - 26 dB Emissions Bandwidth, Middle channel**

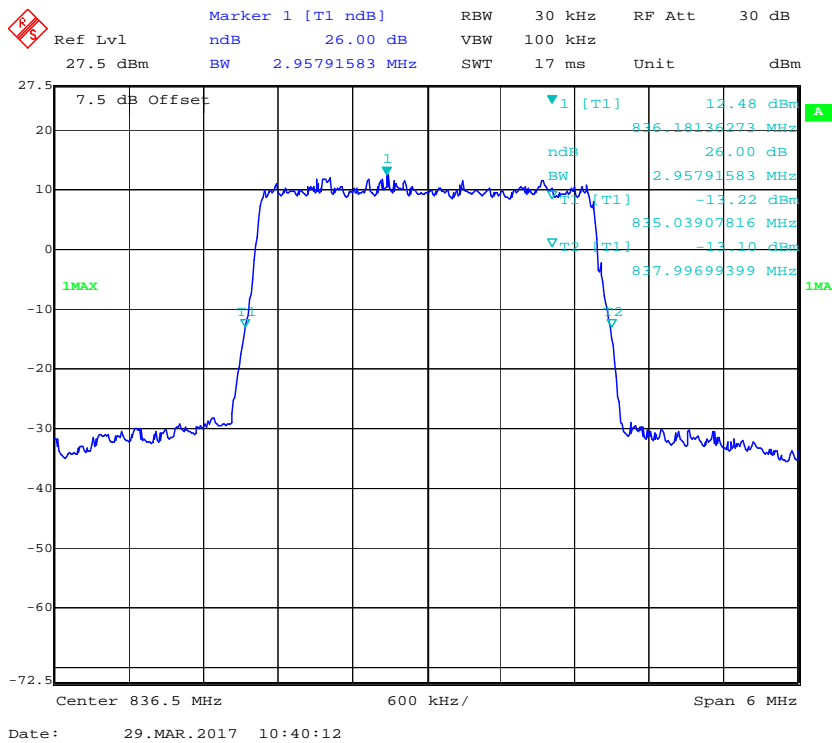

**QPSK (5.0 MHz) - 26 dB Emissions Bandwidth, Middle channel**

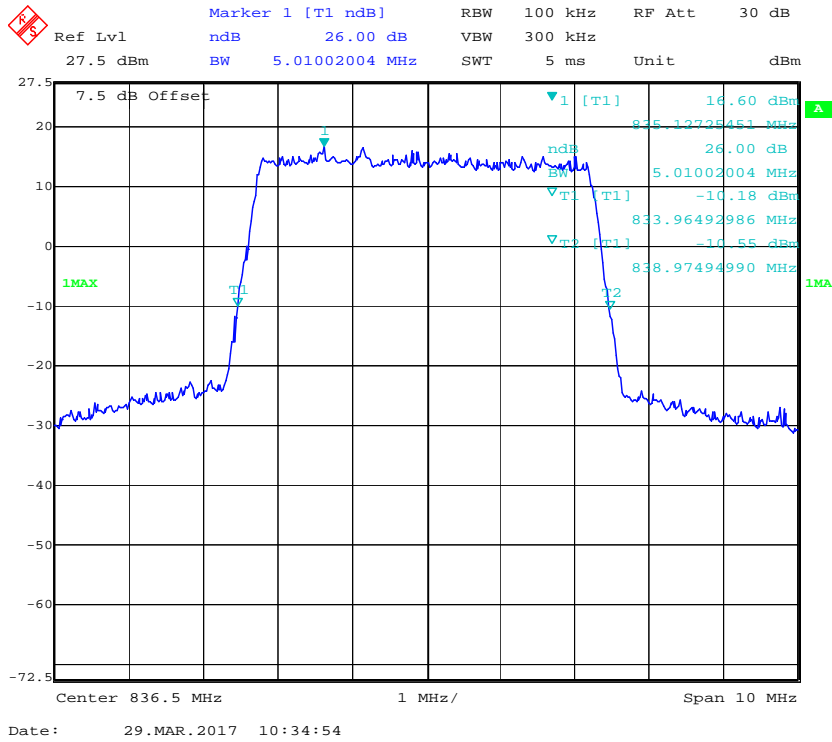

**16-QAM (5.0 MHz) - 26 dB Emissions Bandwidth, Middle channel**

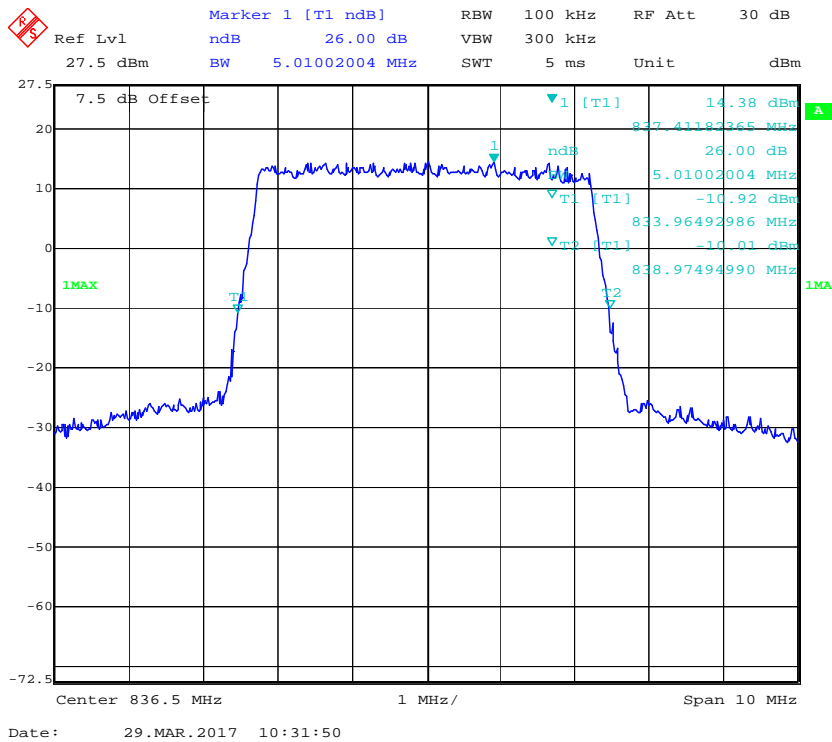

**QPSK (10.0 MHz) - 26 dB Emissions Bandwidth, Middle channel**

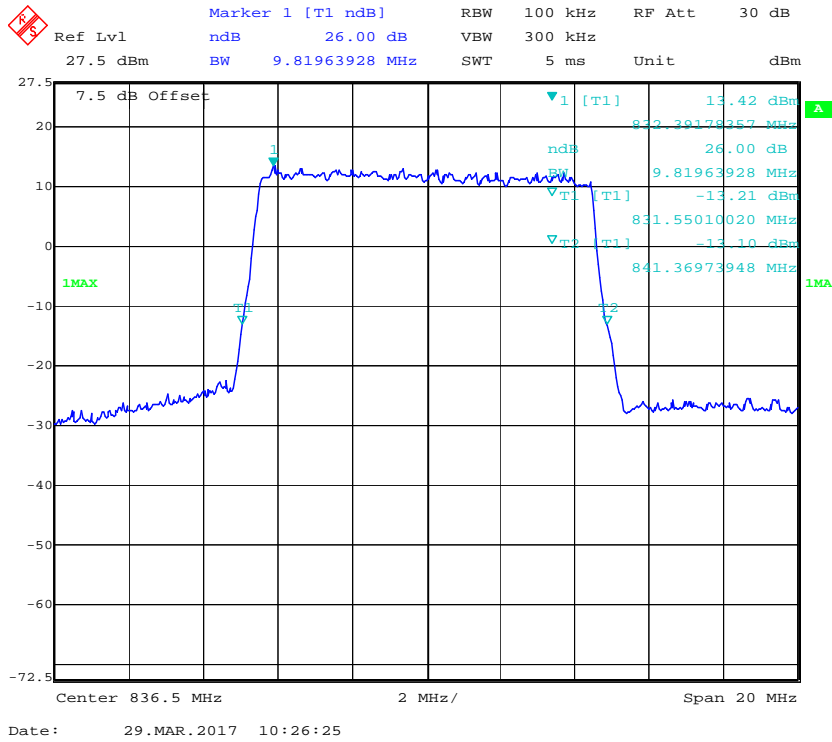

**16-QAM (10.0 MHz) - 26 dB Emissions Bandwidth, Middle channel**

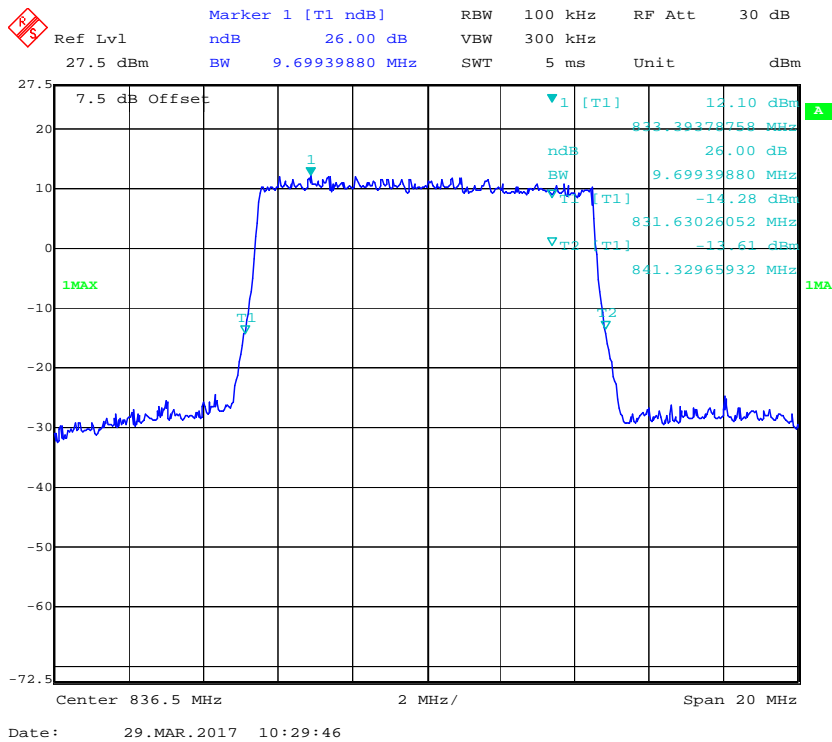

**LTE BAND 7:**

<b>Bandwidth (MHz)</b>	<b>Modulation</b>	<b>99% Occupied Bandwidth (MHz)</b>	<b>26 dB Emission Bandwidth (MHz)</b>
5.0	QPSK	4.509	5.010
	16QAM	4.509	5.050
10.0	QPSK	8.978	9.699
	16QAM	8.938	9.619
15.0	QPSK	14.850	14.790
	16QAM	13.467	14.790
20.0	QPSK	17.876	19.319
	16QAM	17.876	19.479

**QPSK (5.0 MHz) - 99% Occupied Bandwidth, Middle channel**

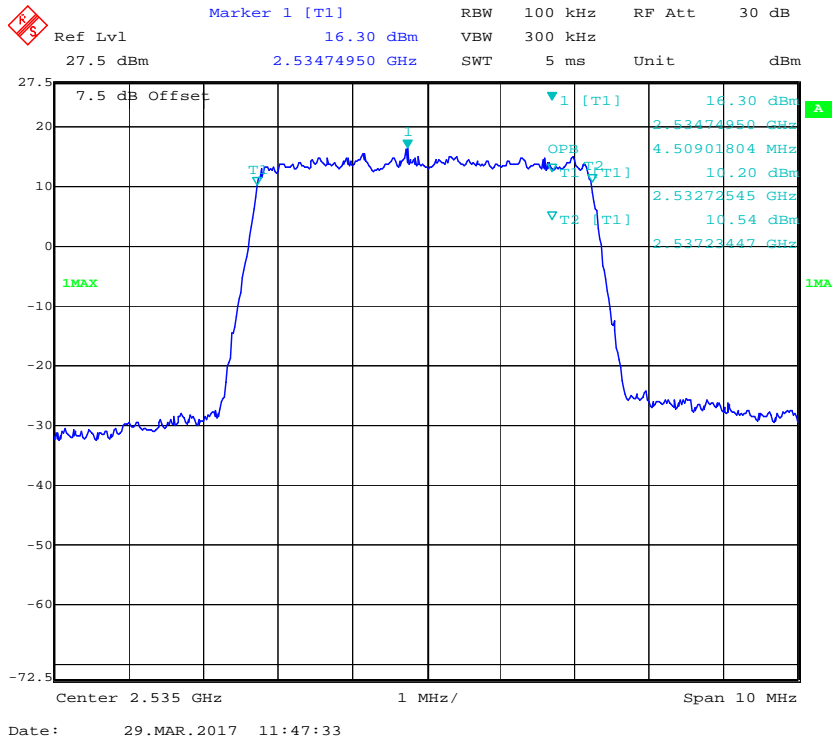

**16-QAM (5.0 MHz) - 99% Occupied Bandwidth, Middle channel**

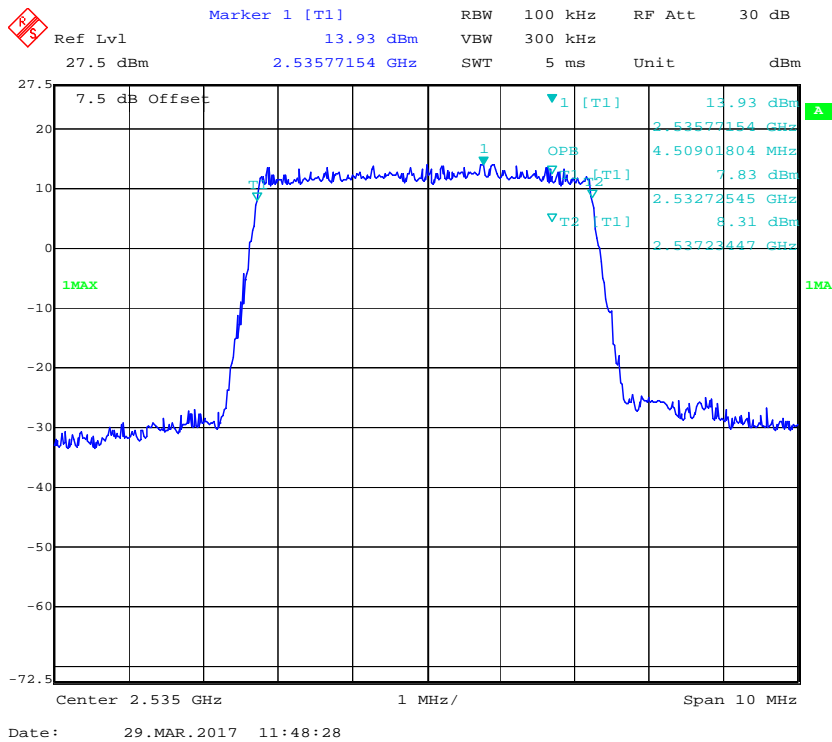

**QPSK (10.0 MHz) - 99% Occupied Bandwidth, Middle channel**

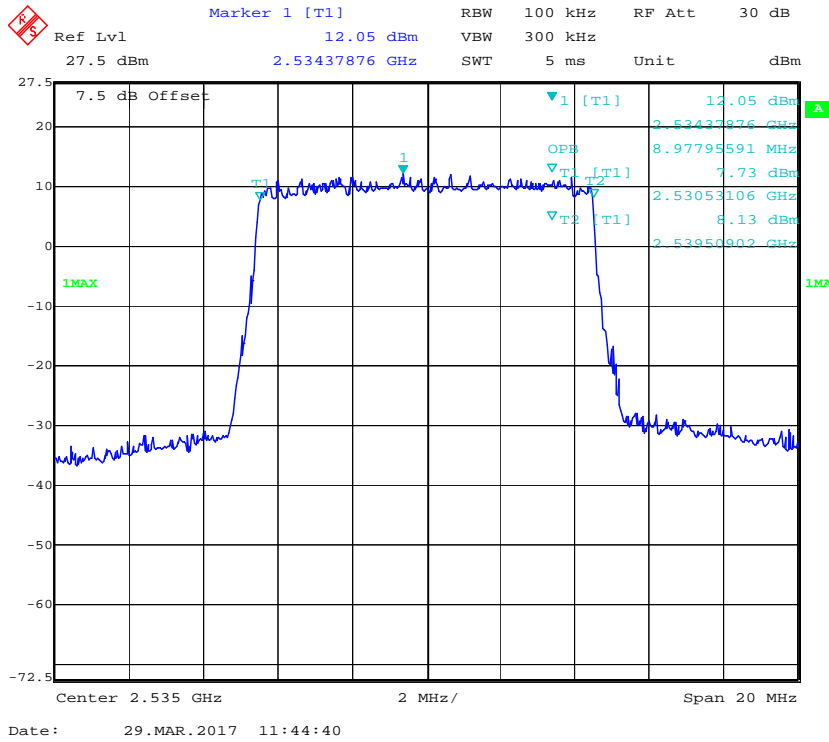

**16-QAM (10.0 MHz) - 99% Occupied Bandwidth, Middle channel**

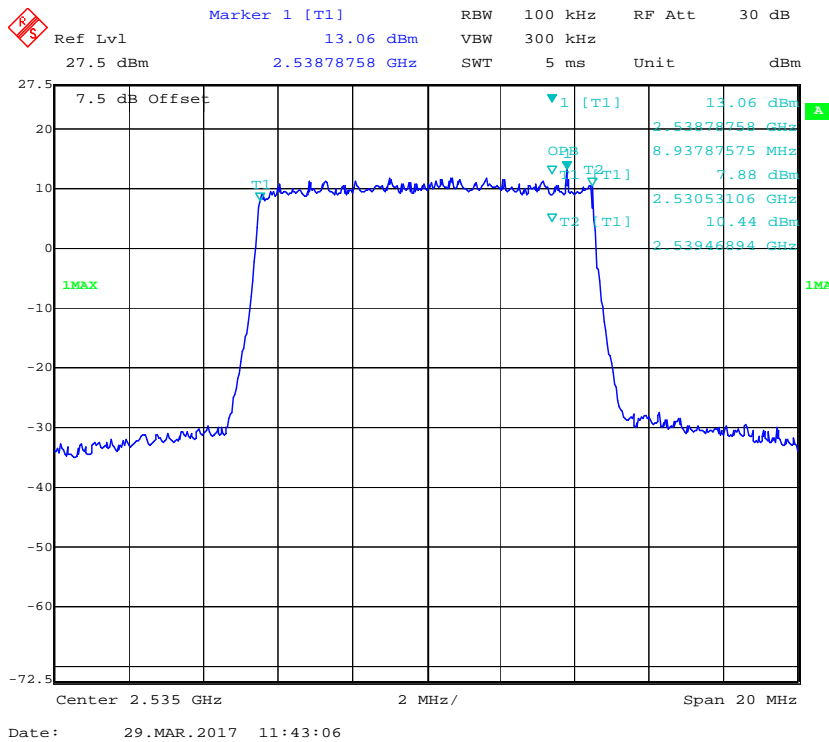

**QPSK (15.0 MHz) - 99% Occupied Bandwidth, Middle channel**

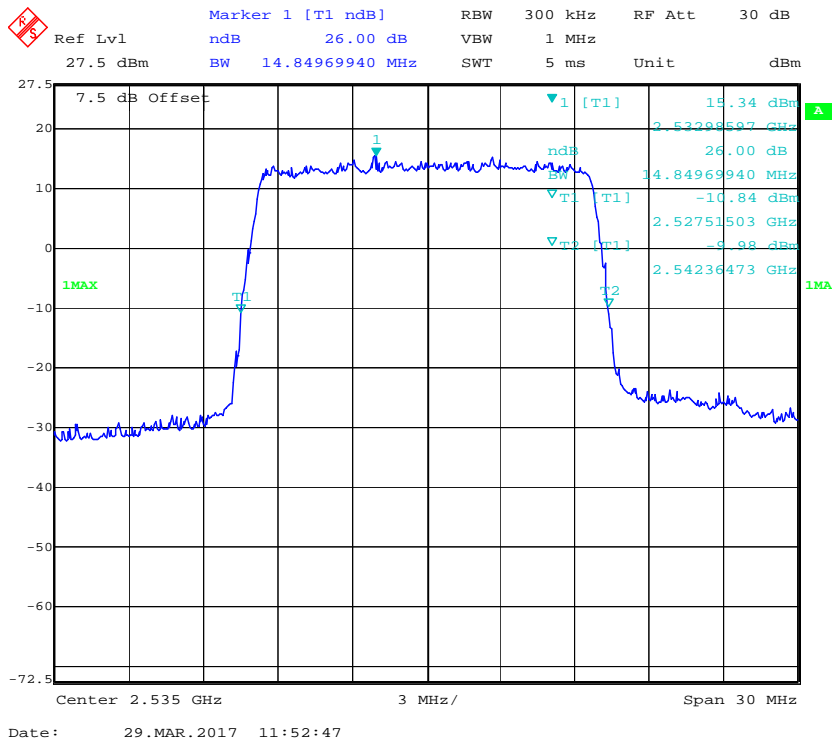

**16-QAM (15.0 MHz) - 99% Occupied Bandwidth, Middle channel**

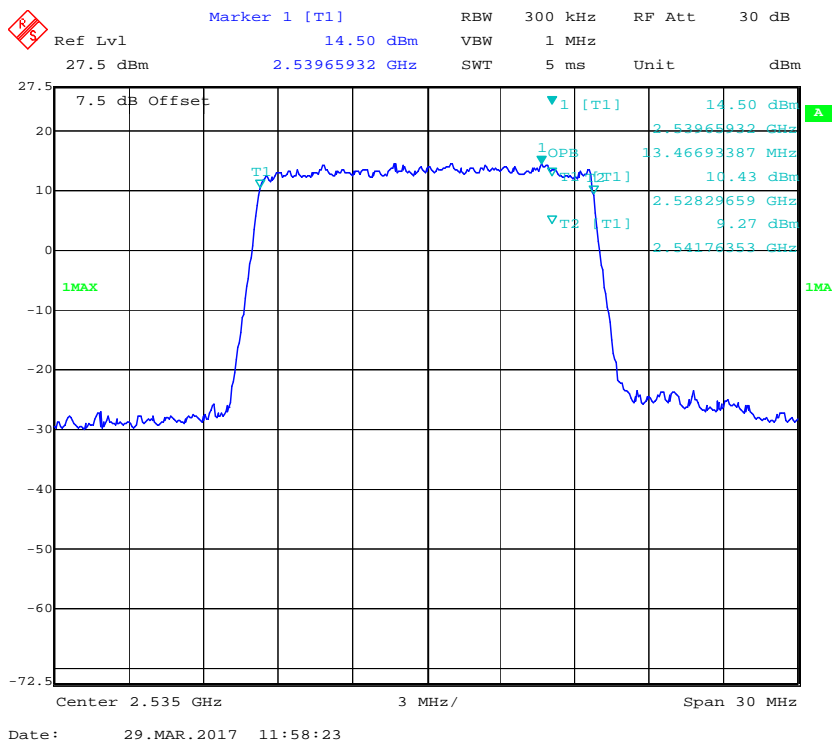



**QPSK (20.0 MHz) - 99% Occupied Bandwidth, Middle channel**

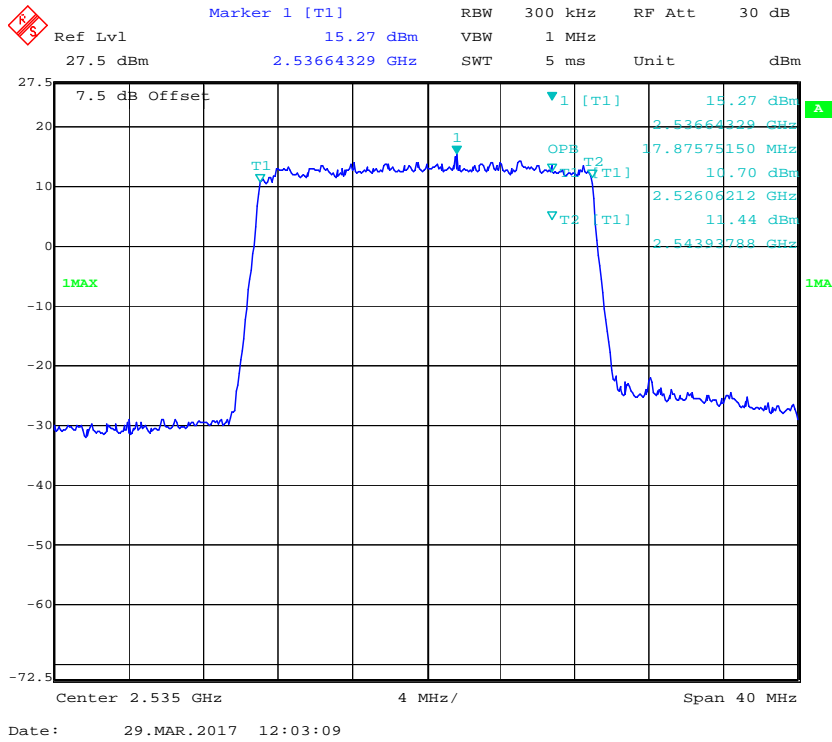

**16-QAM (20.0 MHz) - 99% Occupied Bandwidth, Middle channel**

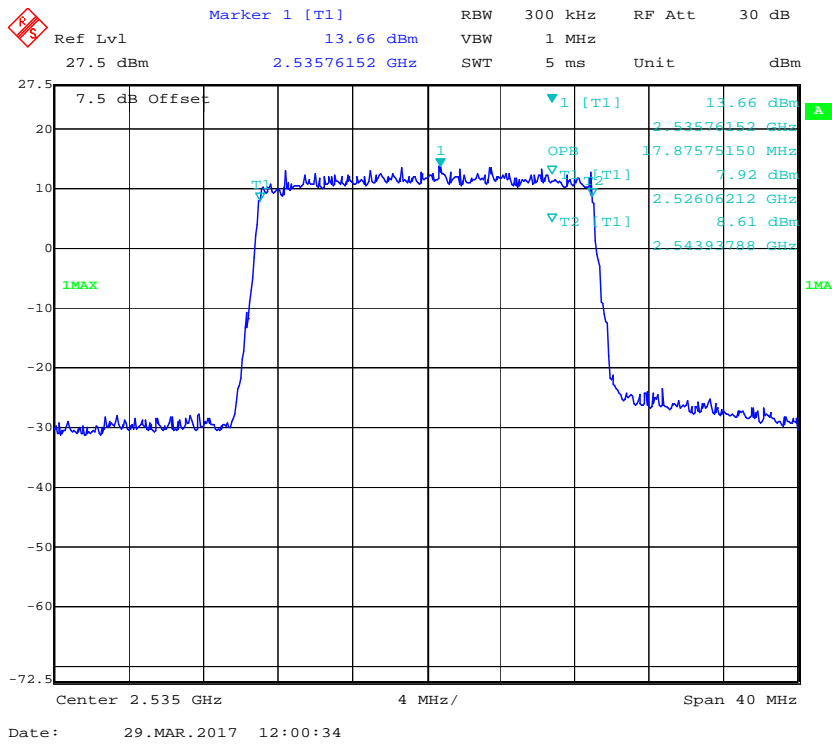

**QPSK (5.0 MHz) - 26 dB Emissions Bandwidth, Middle channel**

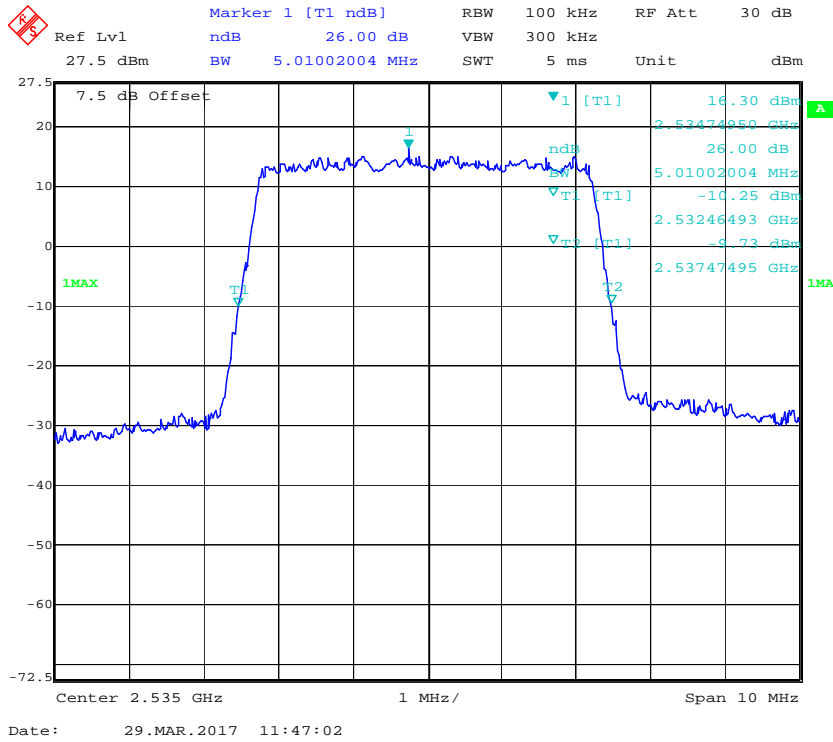

**16-QAM (5.0 MHz) - 26 dB Emissions Bandwidth, Middle channel**

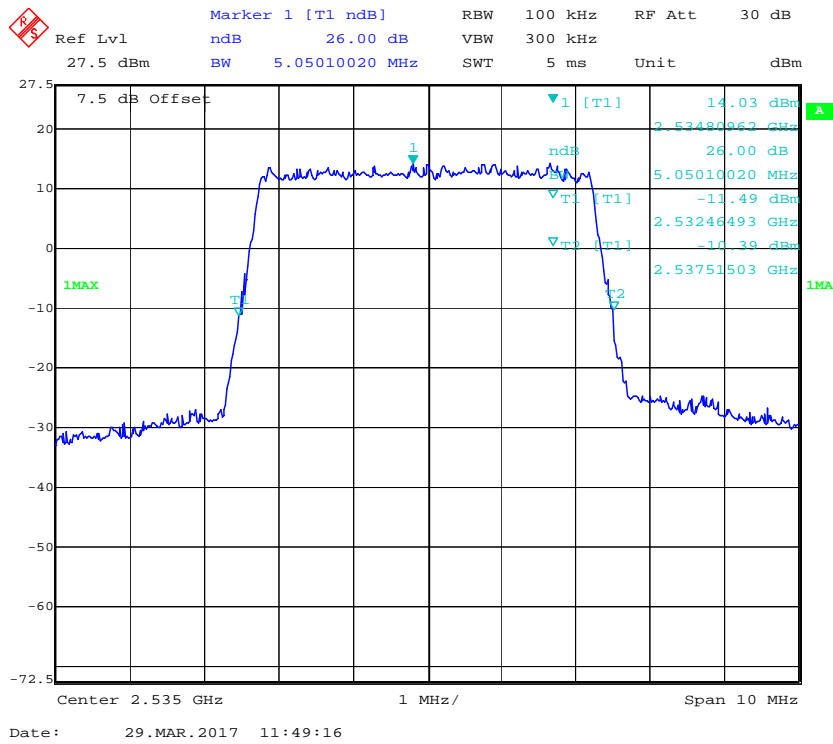

**QPSK (10.0 MHz) - 26 dB Emissions Bandwidth, Middle channel**

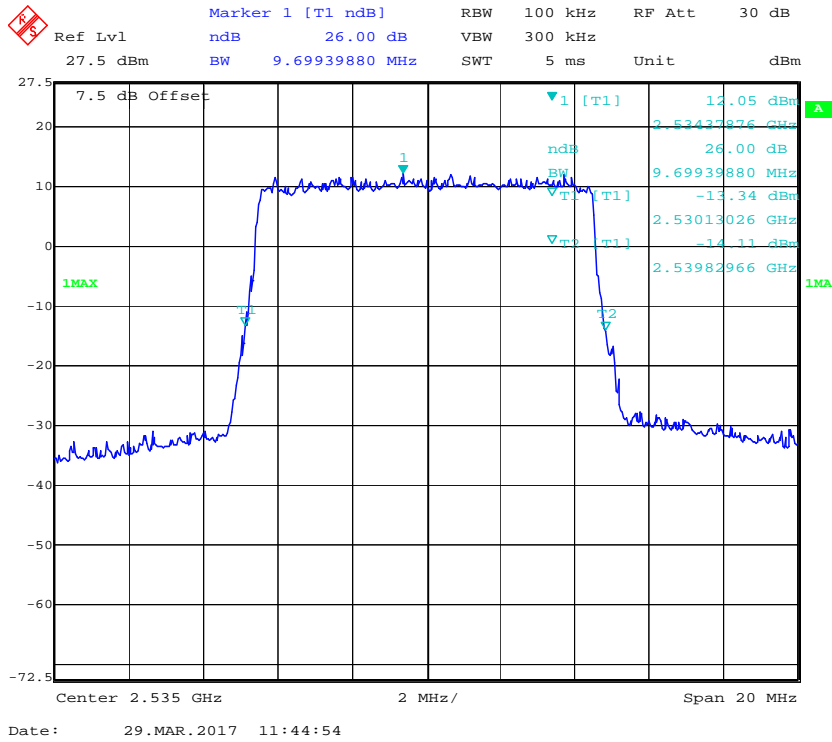

**16-QAM (10.0 MHz) - 26 dB Emissions Bandwidth, Middle channel**

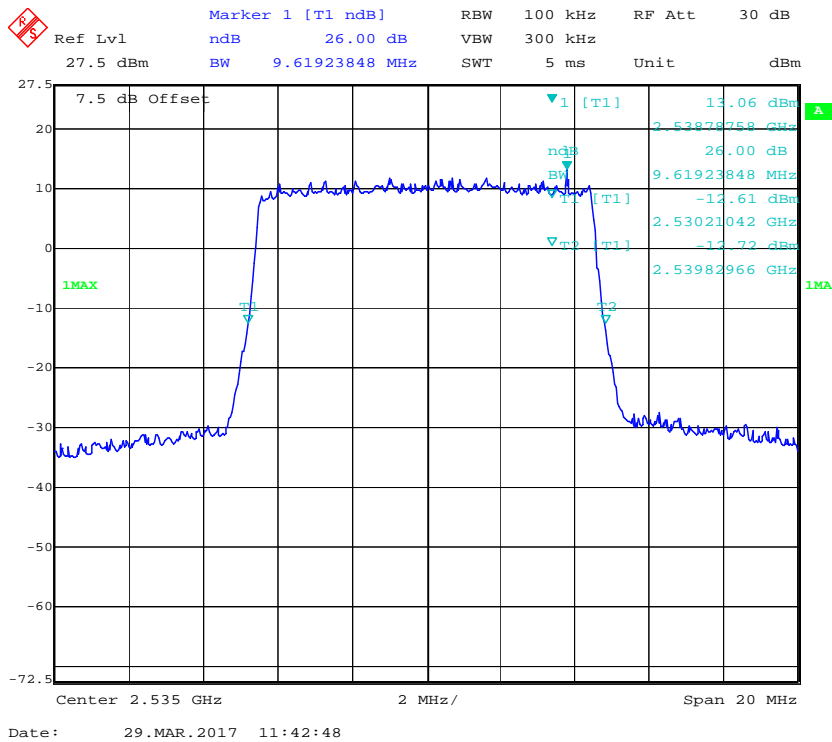

**QPSK (15.0 MHz) - 26 dB Emissions Bandwidth, Middle channel**

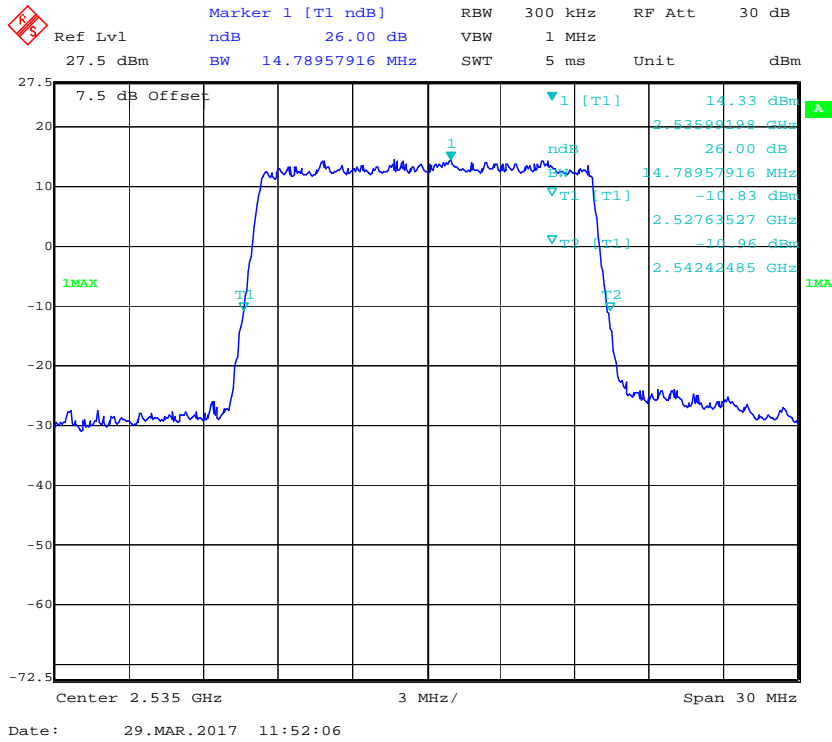

**16-QAM (15.0 MHz) - 26 dB Emissions Bandwidth, Middle channel**

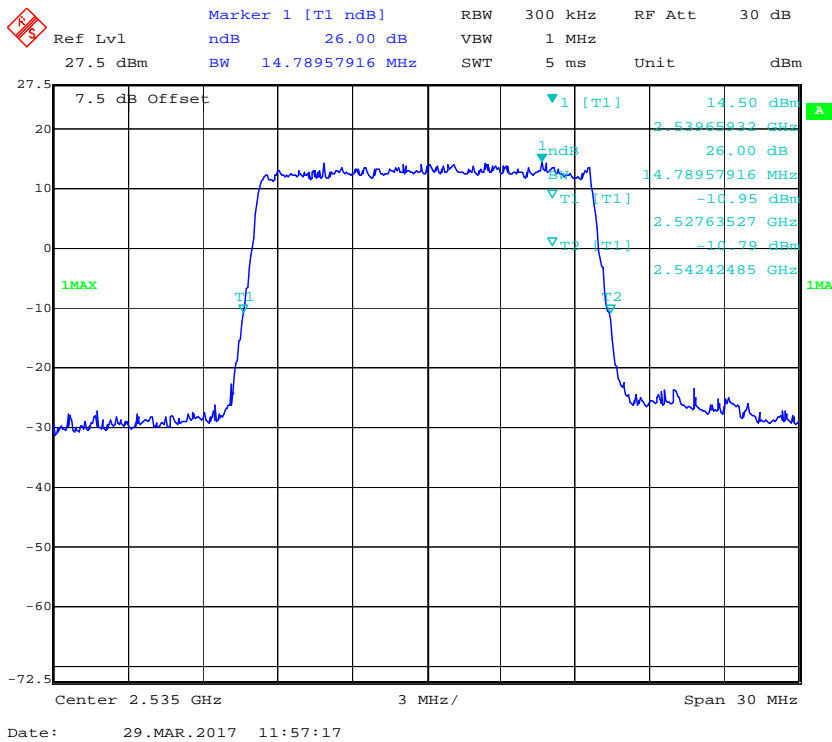

**QPSK (20.0 MHz) - 26 dB Emissions Bandwidth, Middle channel**

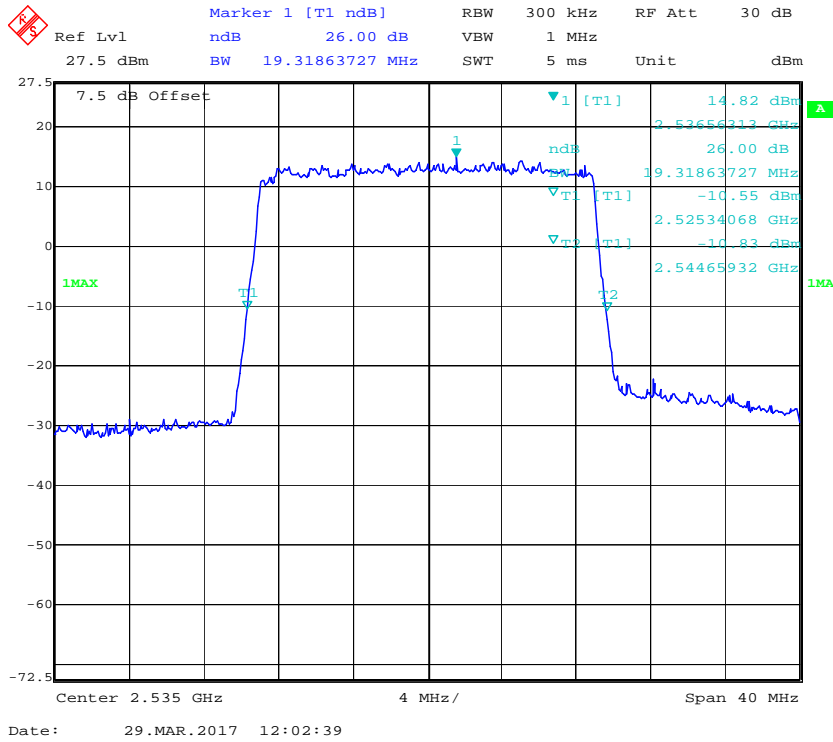

**16-QAM (20.0 MHz) - 26 dB Emissions Bandwidth, Middle channel**

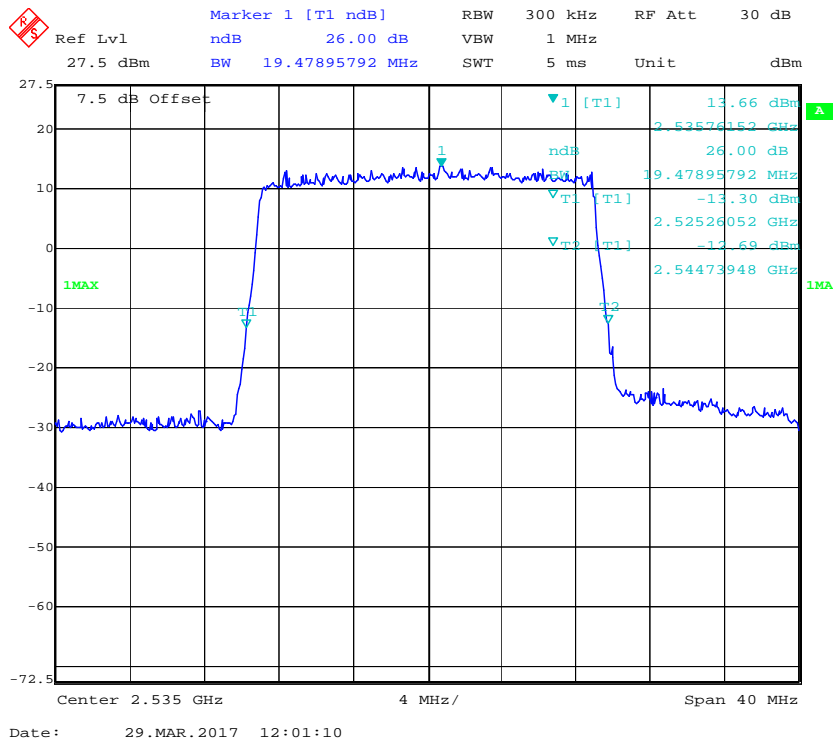

**LTE Band 26: (Middle Channel)**

<b>Bandwidth (MHz)</b>	<b>Modulation</b>	<b>99% Occupied Bandwidth (MHz)</b>	<b>26 dB Emission Bandwidth (MHz)</b>
1.4	QPSK	1.106	1.311
	16QAM	1.112	1.299
3.0	QPSK	2.705	2.934
	16QAM	2.693	2.910
5.0	QPSK	4.549	5.030
	16QAM	4.529	5.010
10.0	QPSK	8.938	9.659
	16QAM	8.938	9.659

**QPSK (1.4 MHz) - 99% Occupied Bandwidth, Middle channel**

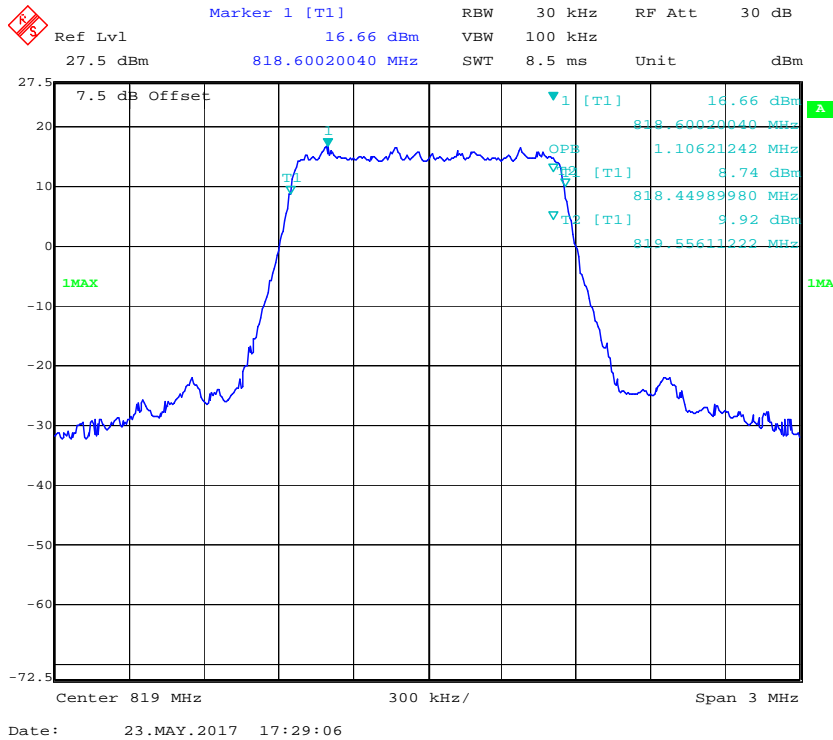

**16-QAM (1.4 MHz) - 99% Occupied Bandwidth, Middle channel**

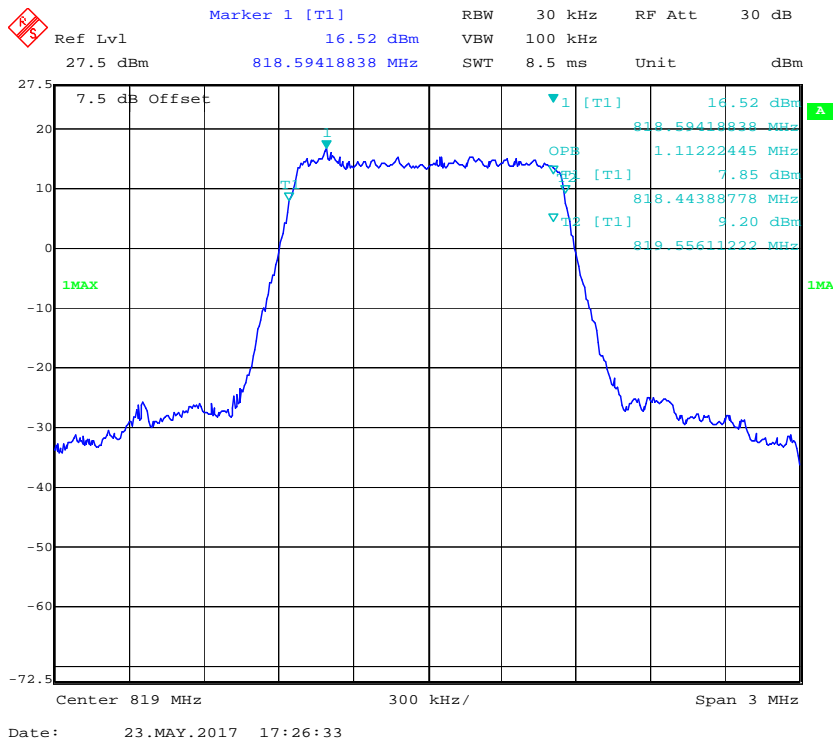

**QPSK (3.0 MHz) - 99% Occupied Bandwidth, Middle channel**

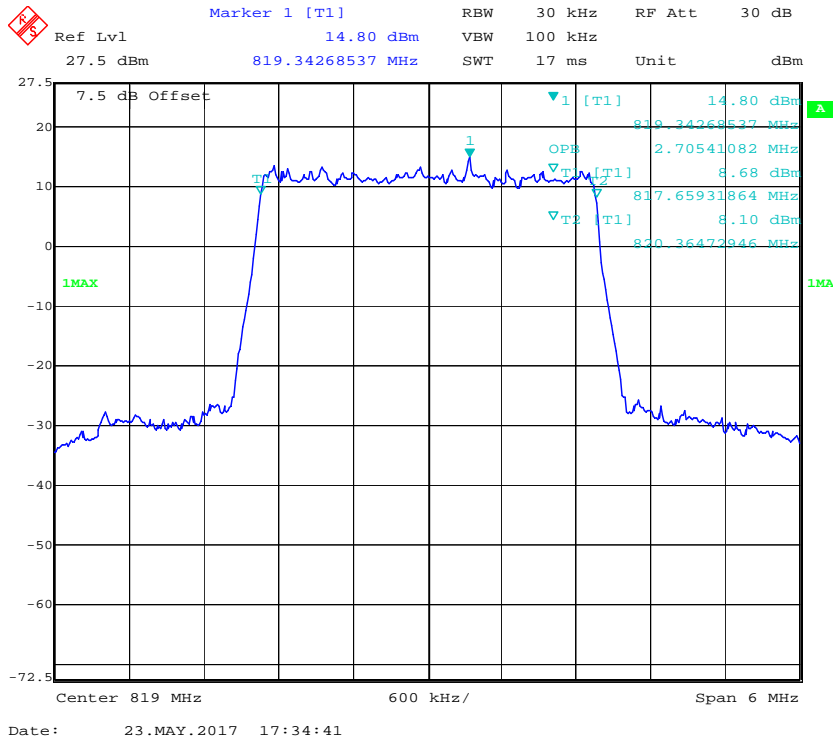

**16-QAM (3.0 MHz) - 99% Occupied Bandwidth, Middle channel**

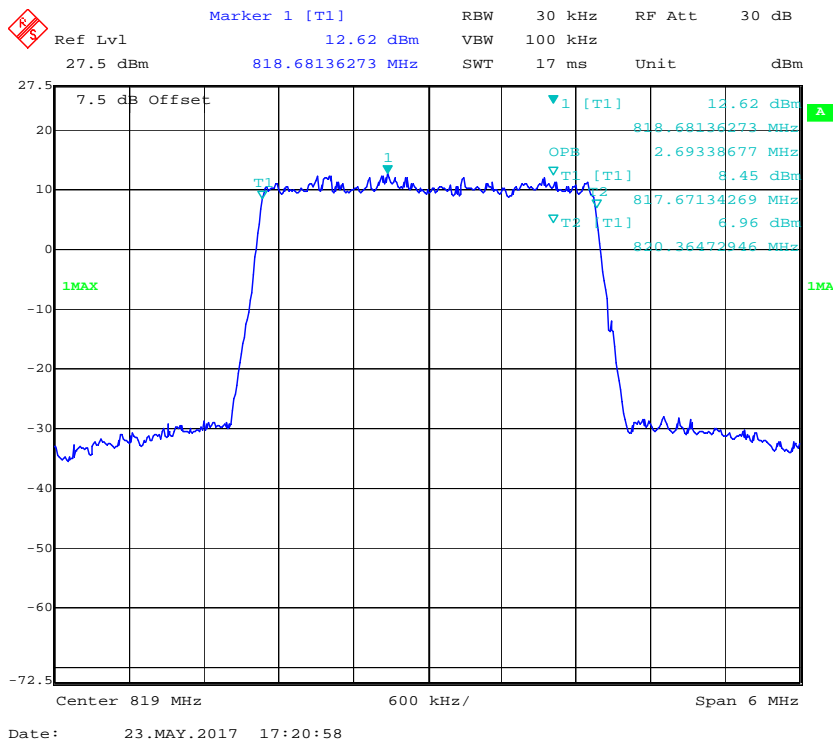



**QPSK (5.0 MHz) - 99% Occupied Bandwidth, Middle channel**

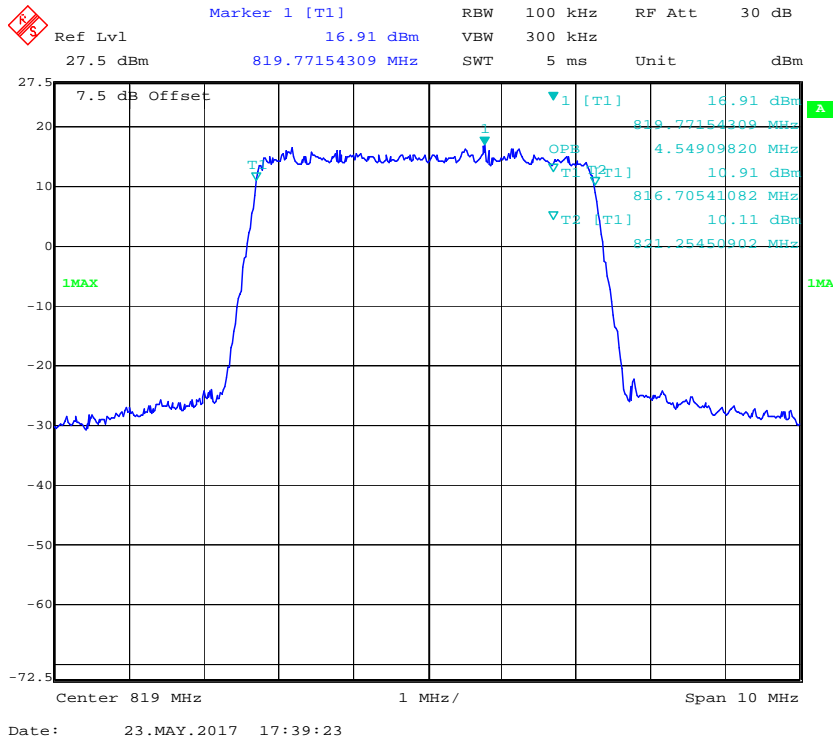

**16-QAM (5.0 MHz) - 99% Occupied Bandwidth, Middle channel**

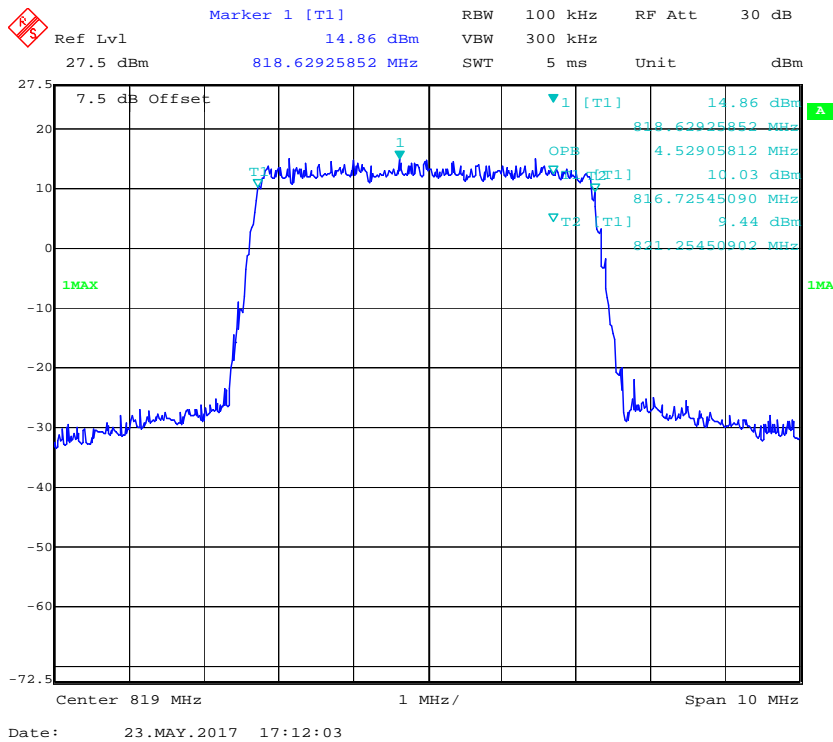

**QPSK (10.0 MHz) - 99% Occupied Bandwidth, Middle channel**

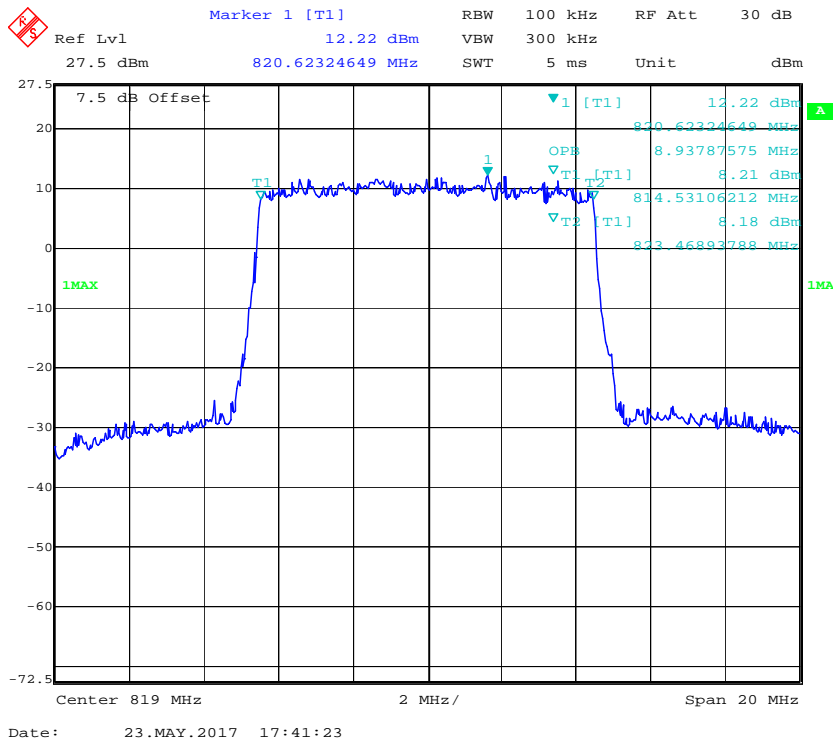

**16-QAM (10.0 MHz) - 99% Occupied Bandwidth, Middle channel**

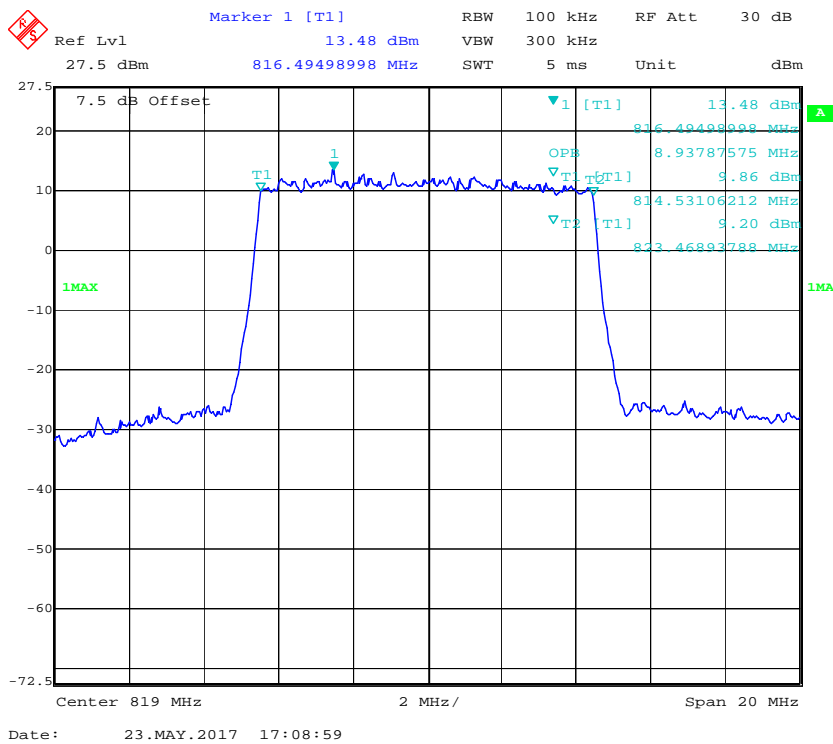

**QPSK (1.4 MHz) - 26 dB Emissions Bandwidth, Middle channel**



**16-QAM (1.4 MHz) - 26 dB Emissions Bandwidth, Middle channel**

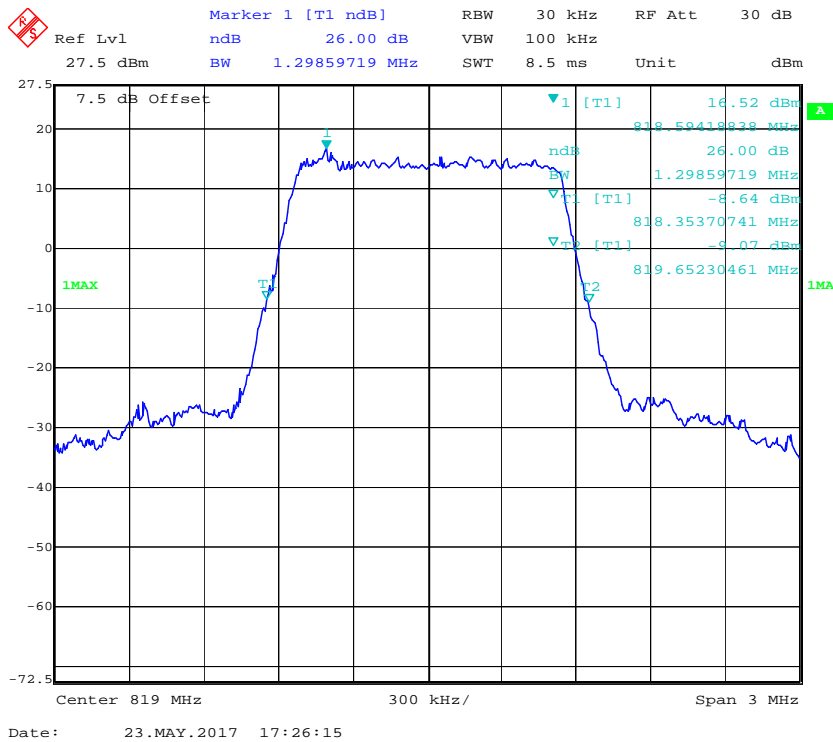

**QPSK (3.0 MHz) - 26 dB Emissions Bandwidth, Middle channel**

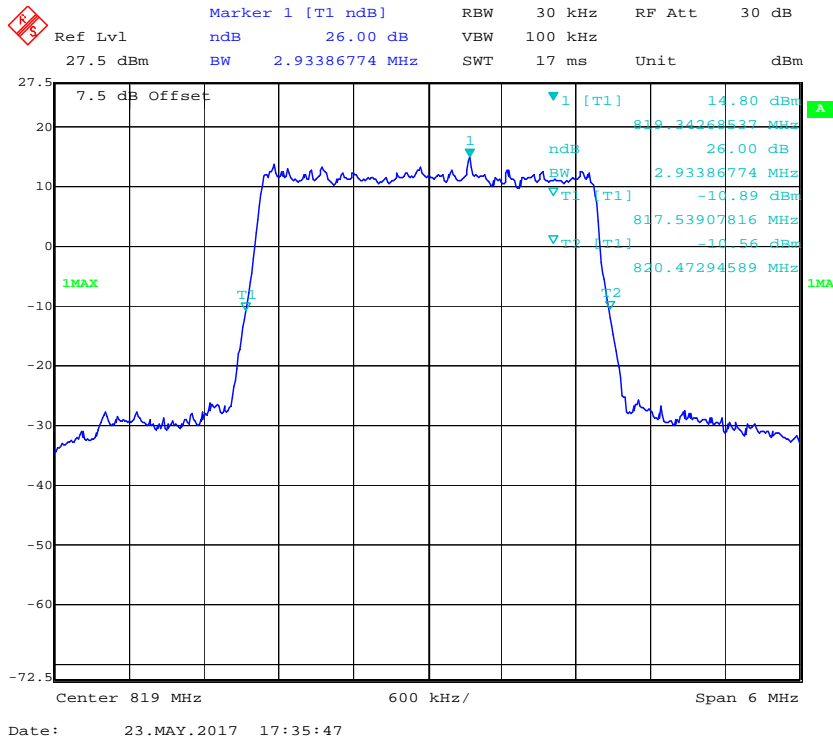

**16-QAM (3.0 MHz) - 26 dB Emissions Bandwidth, Middle channel**

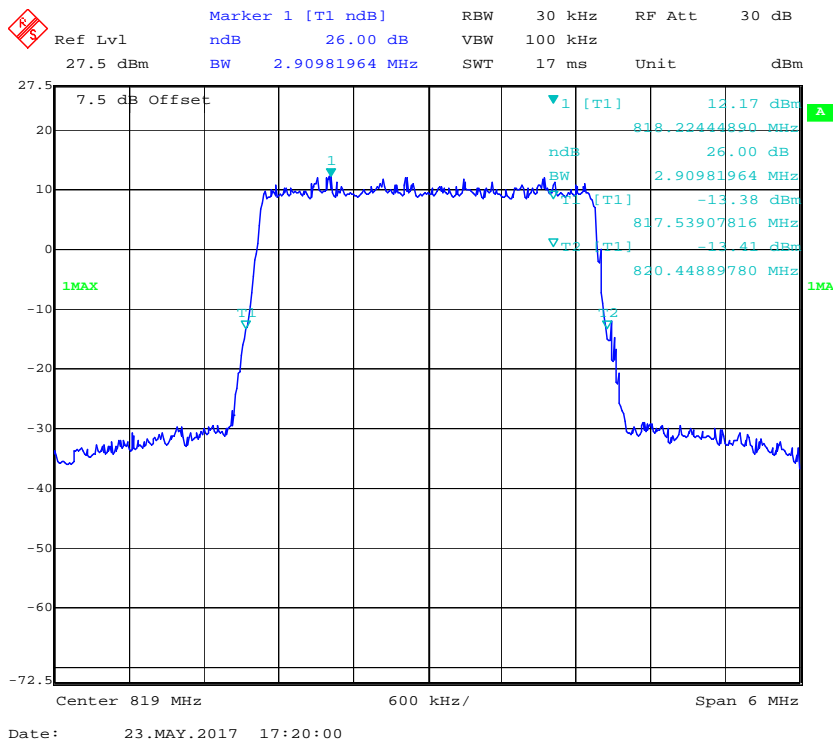

**QPSK (5.0 MHz) - 26 dB Emissions Bandwidth, Middle channel**

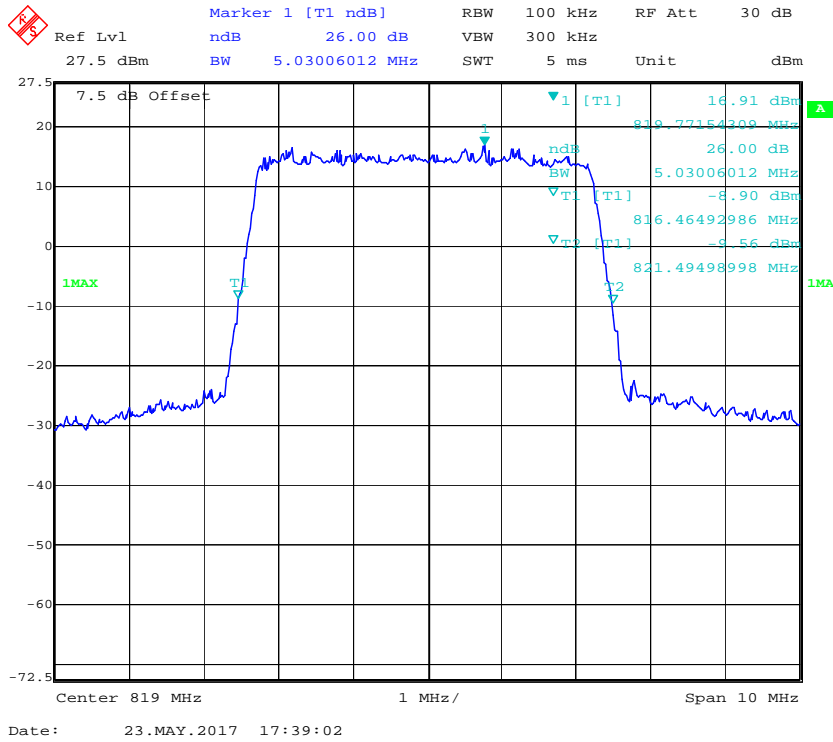

**16-QAM (5.0 MHz) - 26 dB Emissions Bandwidth, Middle channel**

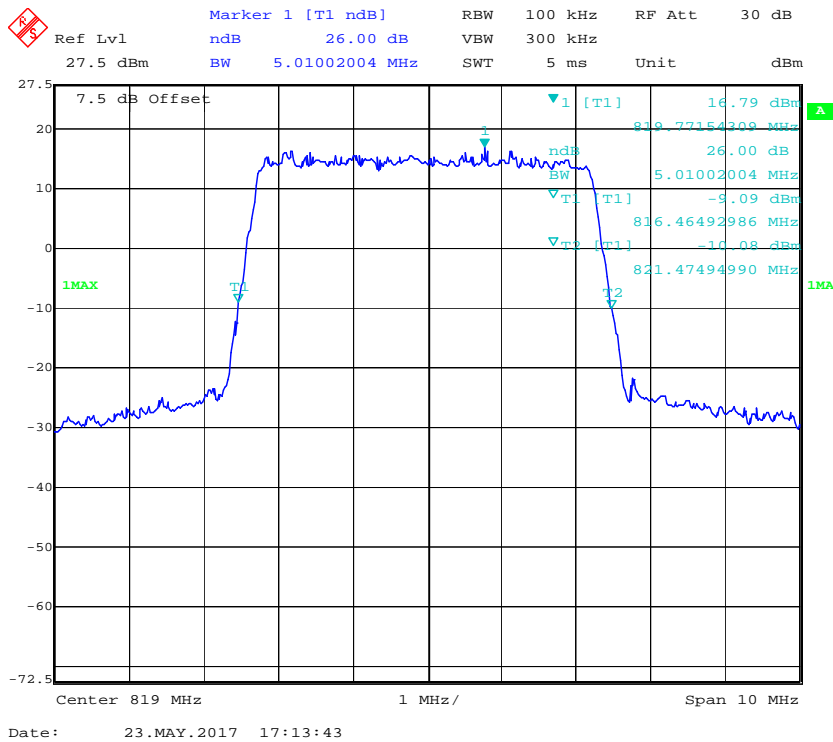

**QPSK (10.0 MHz) - 26 dB Emissions Bandwidth, Middle channel**

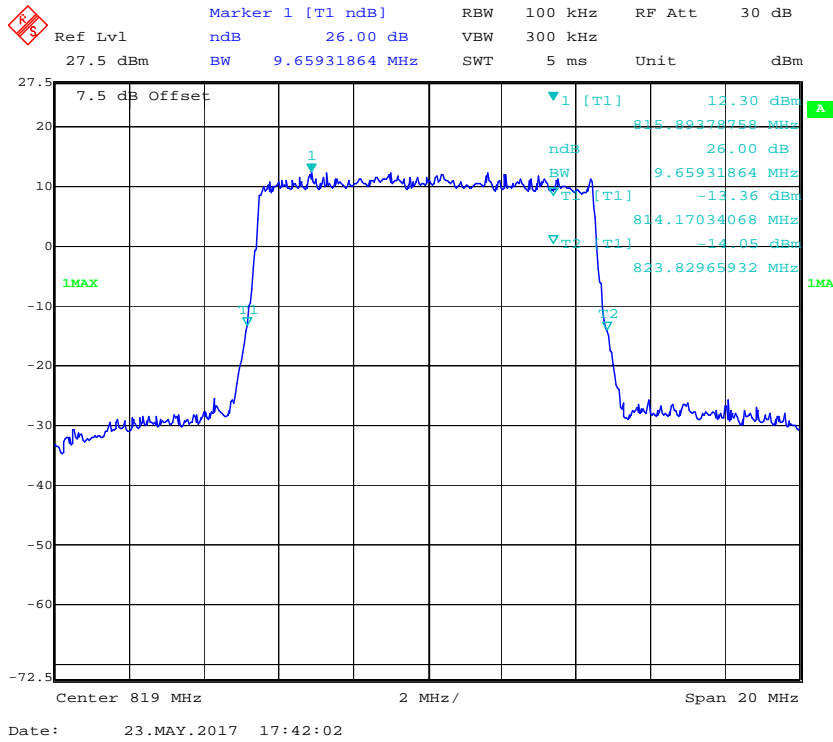

**16-QAM (10.0 MHz) - 26 dB Emissions Bandwidth, Middle channel**

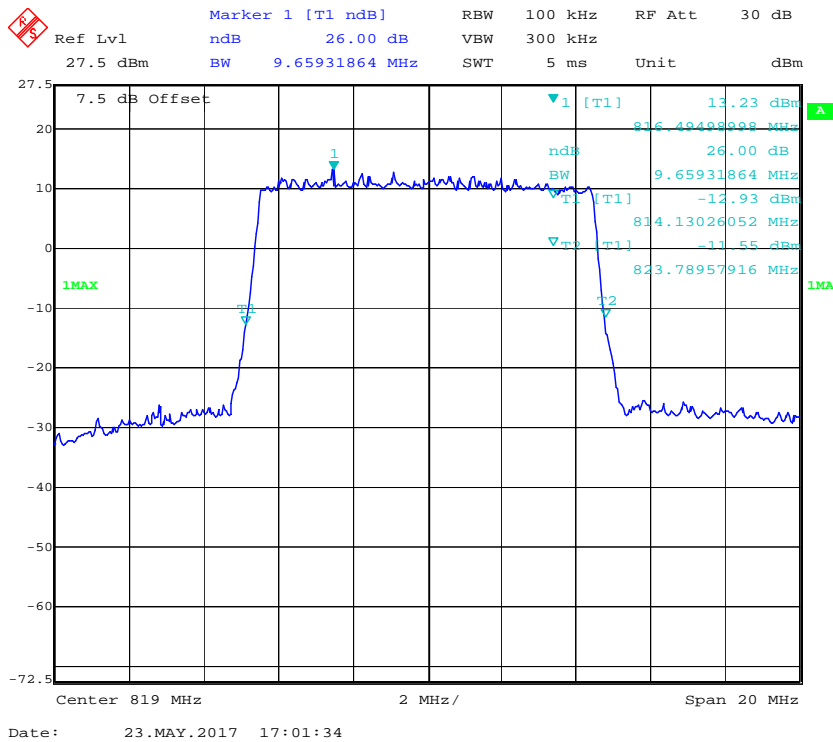

**LTE BAND 38:**

<b>Bandwidth (MHz)</b>	<b>Modulation</b>	<b>99% Occupied Bandwidth (MHz)</b>	<b>26 dB Emission Bandwidth (MHz)</b>
5.0	QPSK	4.509	5.030
	16QAM	4.529	5.090
10.0	QPSK	8.978	10.180
	16QAM	8.978	9.659
15.0	QPSK	13.527	15.391
	16QAM	13.587	15.691
20.0	QPSK	17.976	19.419
	16QAM	17.976	19.359

**QPSK (5.0 MHz) - 99% Occupied Bandwidth, Middle channel**

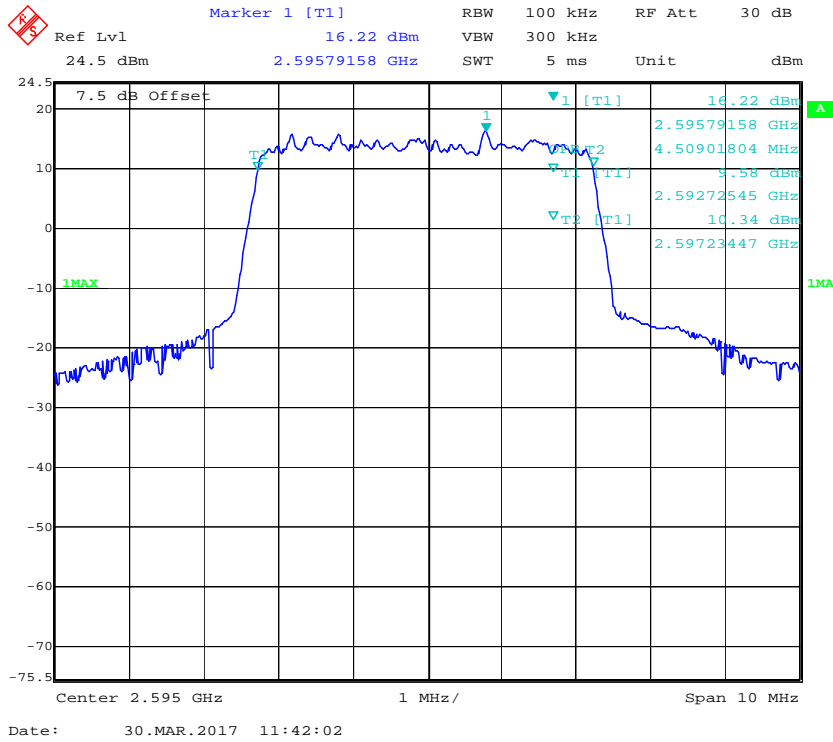

**16-QAM (5.0 MHz) - 99% Occupied Bandwidth, Middle channel**

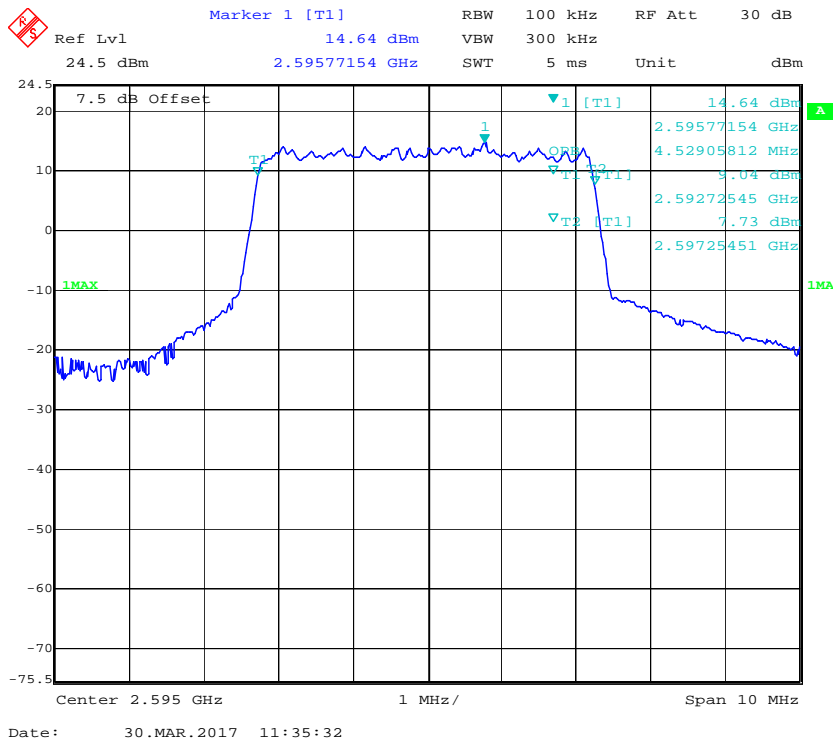



**QPSK (10.0 MHz) - 99% Occupied Bandwidth, Middle channel**

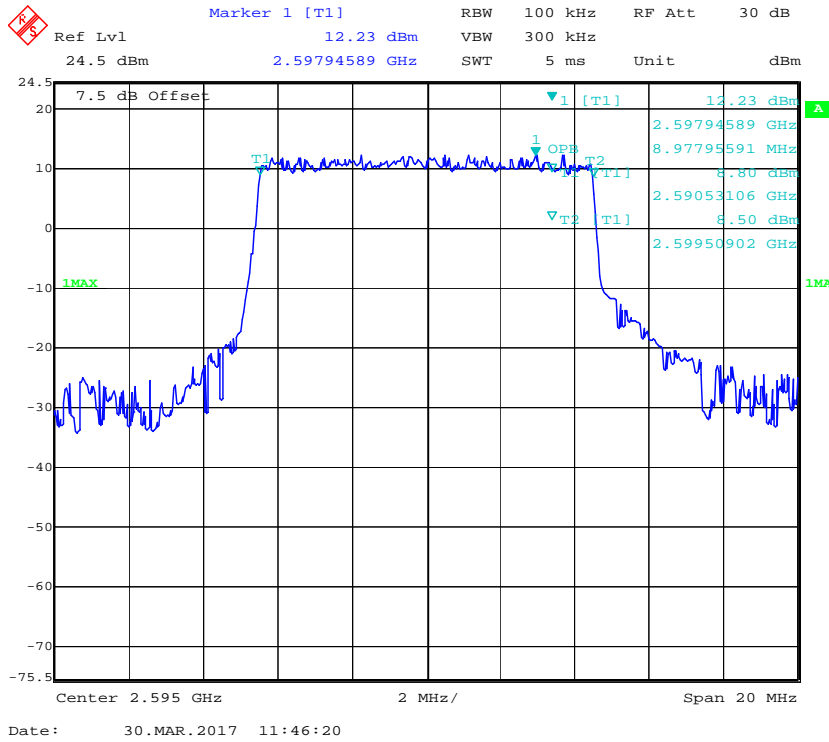

**16-QAM (10.0 MHz) - 99% Occupied Bandwidth, Middle channel**

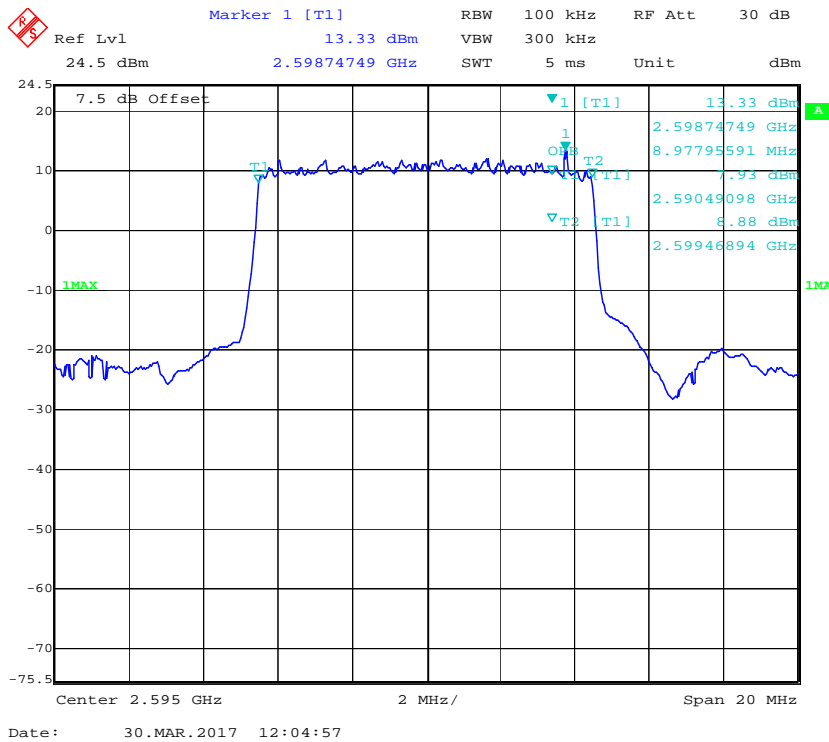

**QPSK (15.0 MHz) - 99% Occupied Bandwidth, Middle channel**

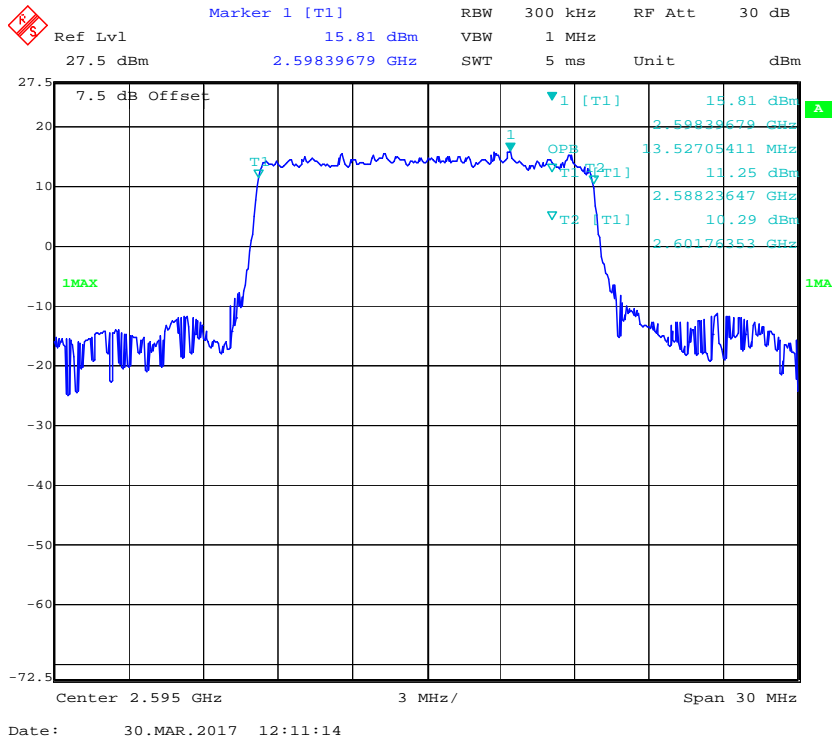

**16-QAM (15.0 MHz) - 99% Occupied Bandwidth, Middle channel**

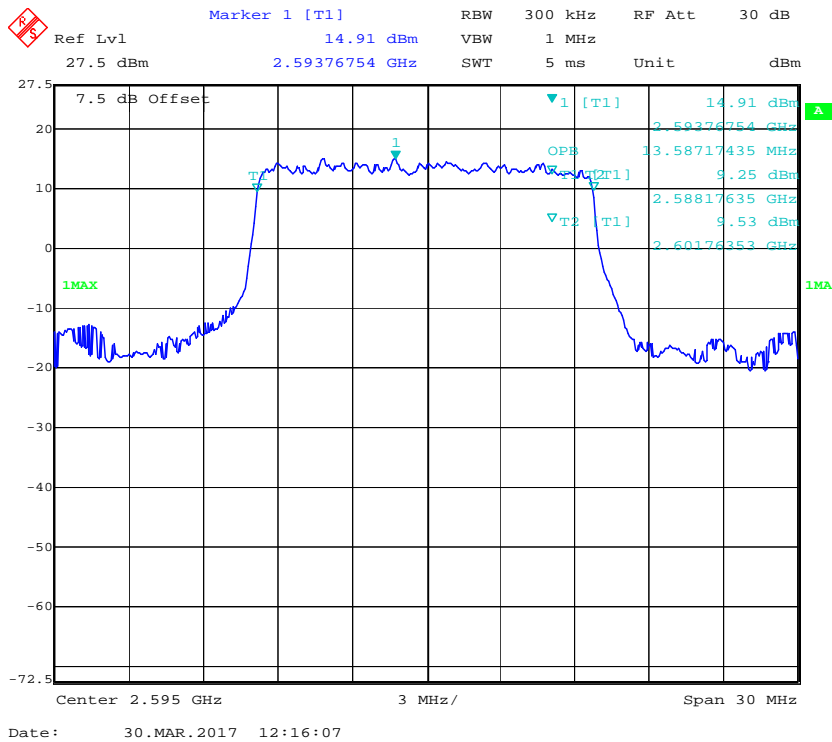

**QPSK (20.0 MHz) - 99% Occupied Bandwidth, Middle channel**

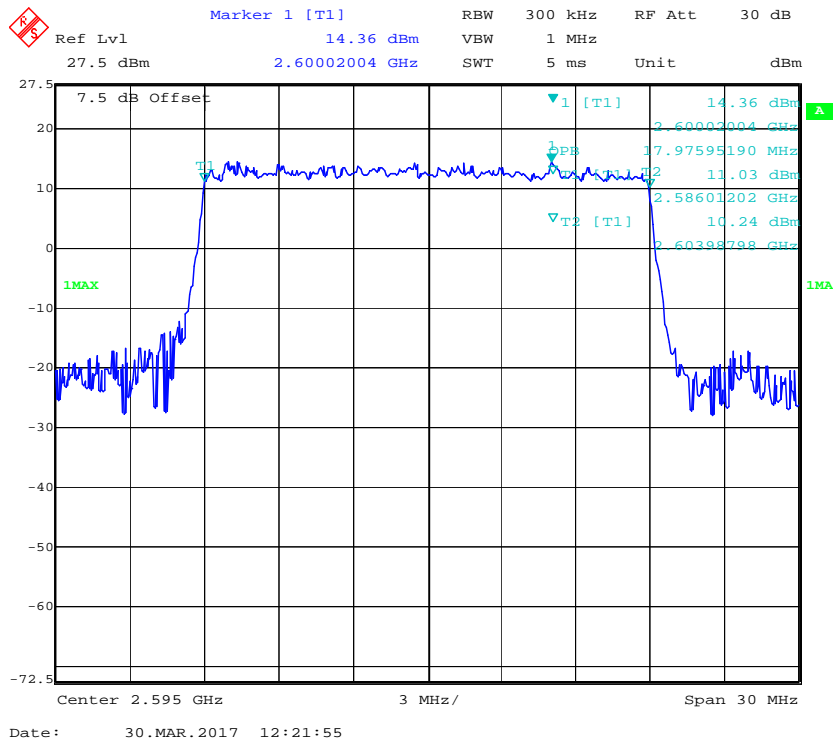

**16-QAM (20.0 MHz) - 99% Occupied Bandwidth, Middle channel**

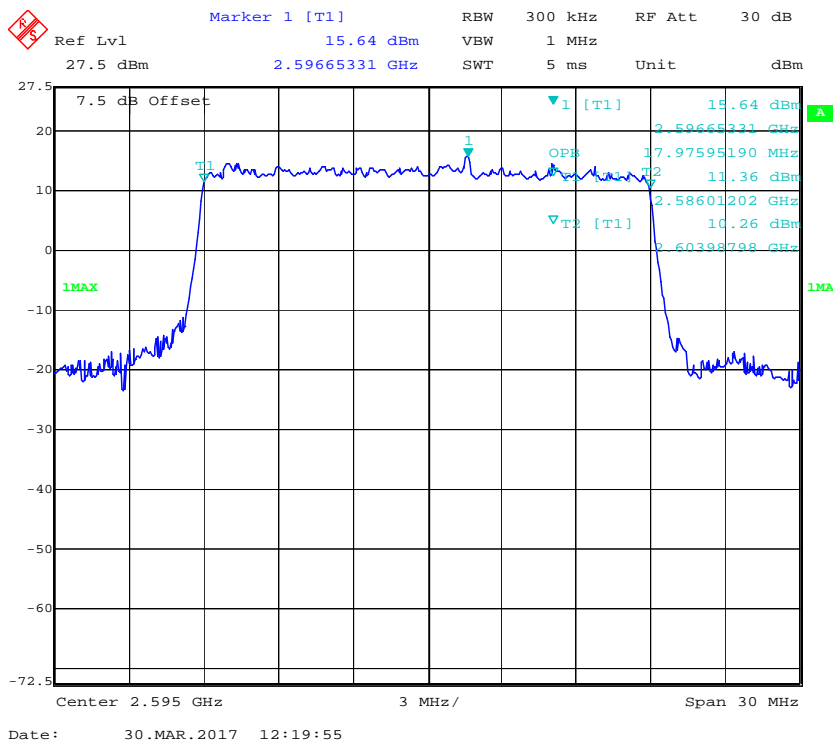

**QPSK (5.0 MHz) - 26 dB Emissions Bandwidth, Middle channel**

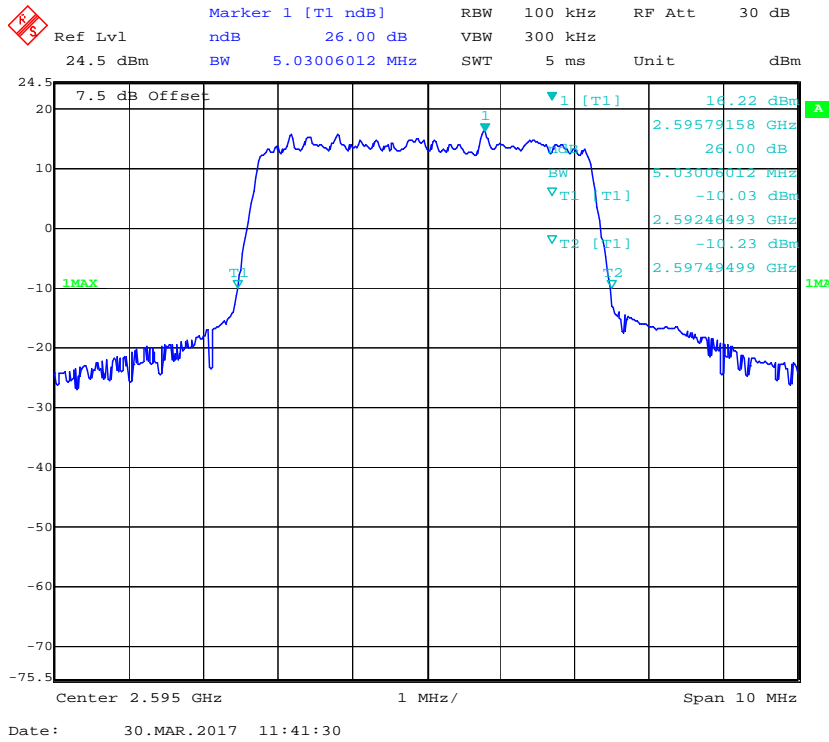

**16-QAM (5.0 MHz) - 26 dB Emissions Bandwidth, Middle channel**

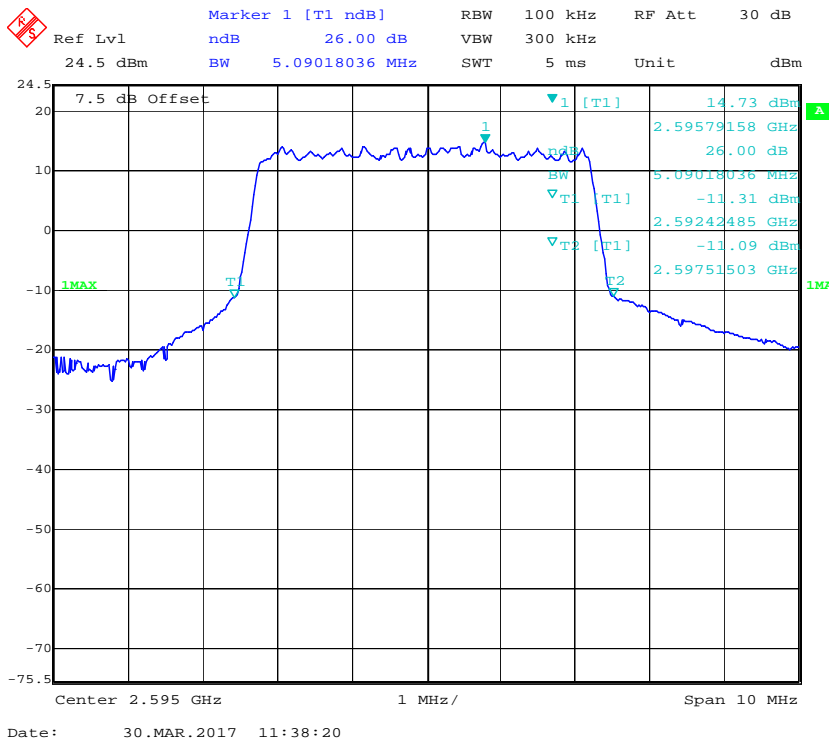

**QPSK (10.0 MHz) - 26 dB Emissions Bandwidth, Middle channel**

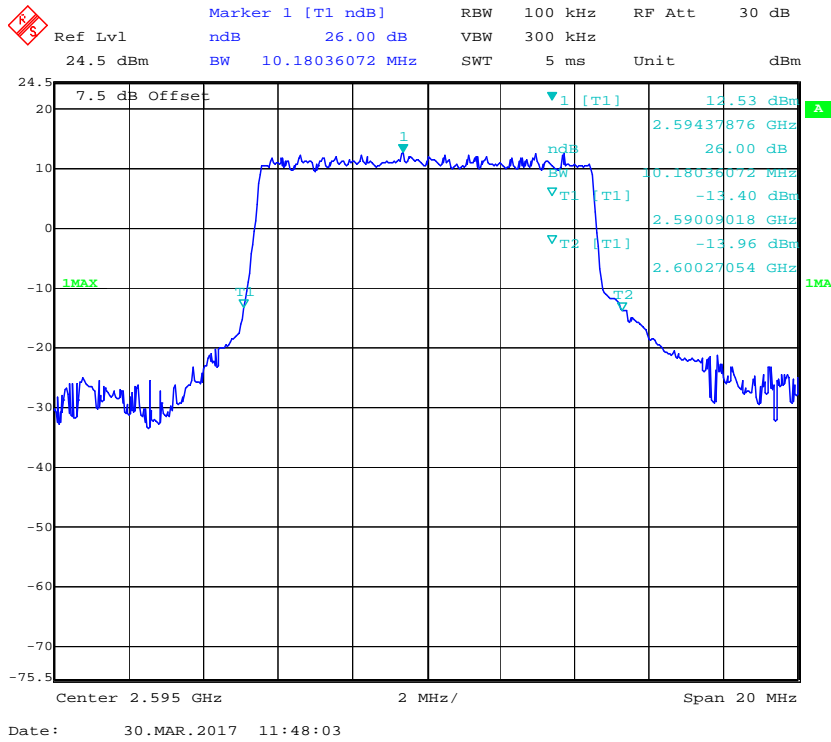

**16-QAM (10.0 MHz) - 26 dB Emissions Bandwidth, Middle channel**

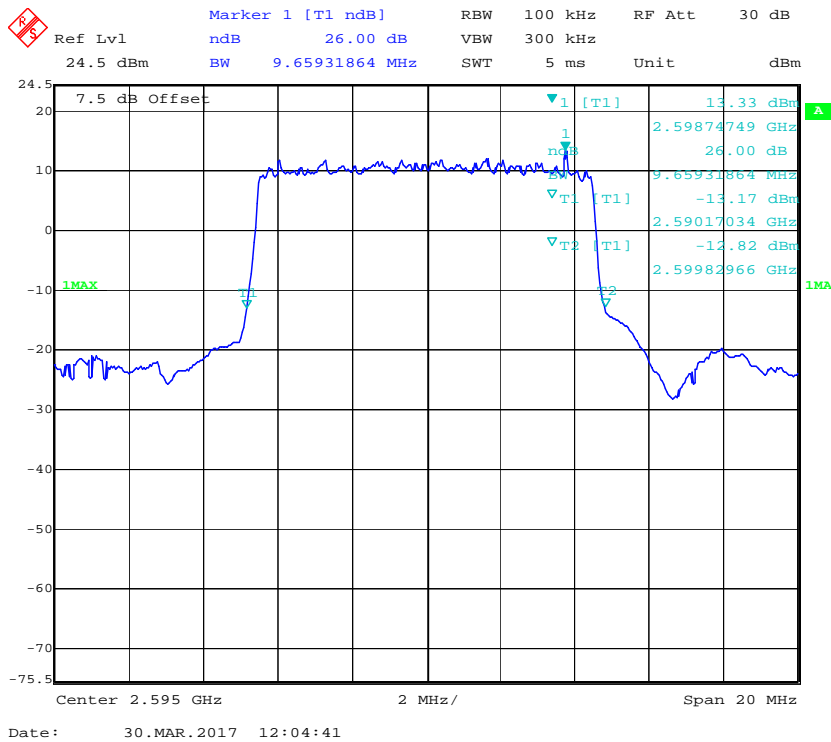

**QPSK (15.0 MHz) - 26 dB Emissions Bandwidth, Middle channel**

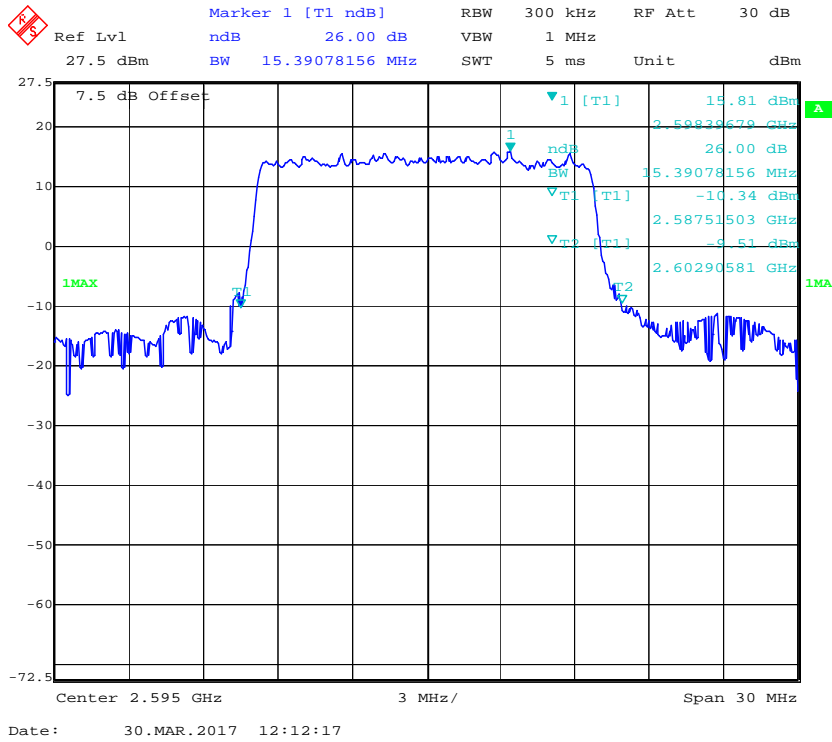

**16-QAM (15.0 MHz) - 26 dB Emissions Bandwidth, Middle channel**

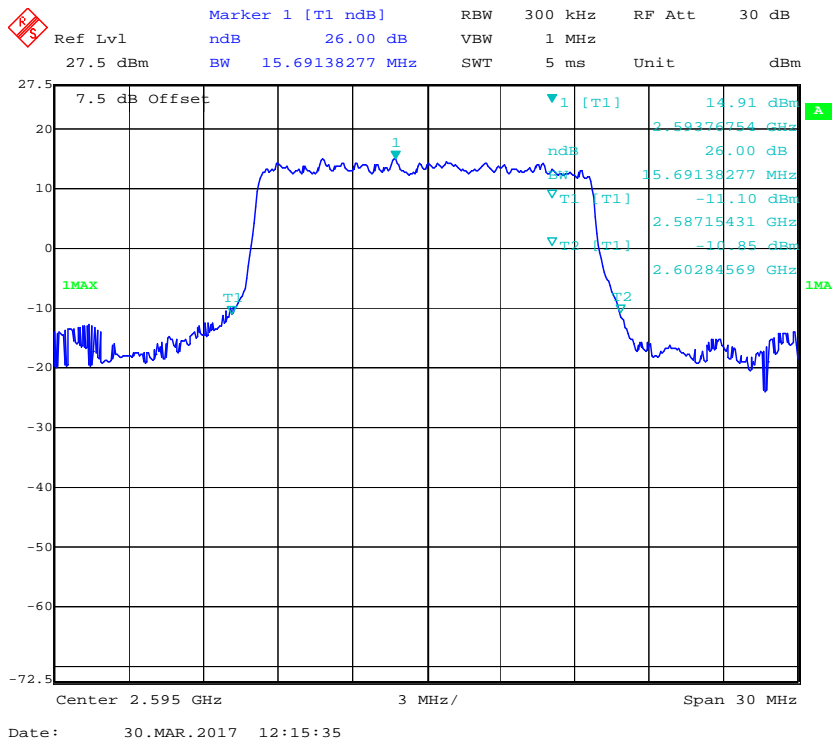

**QPSK (20.0 MHz) - 26 dB Emissions Bandwidth, Middle channel**

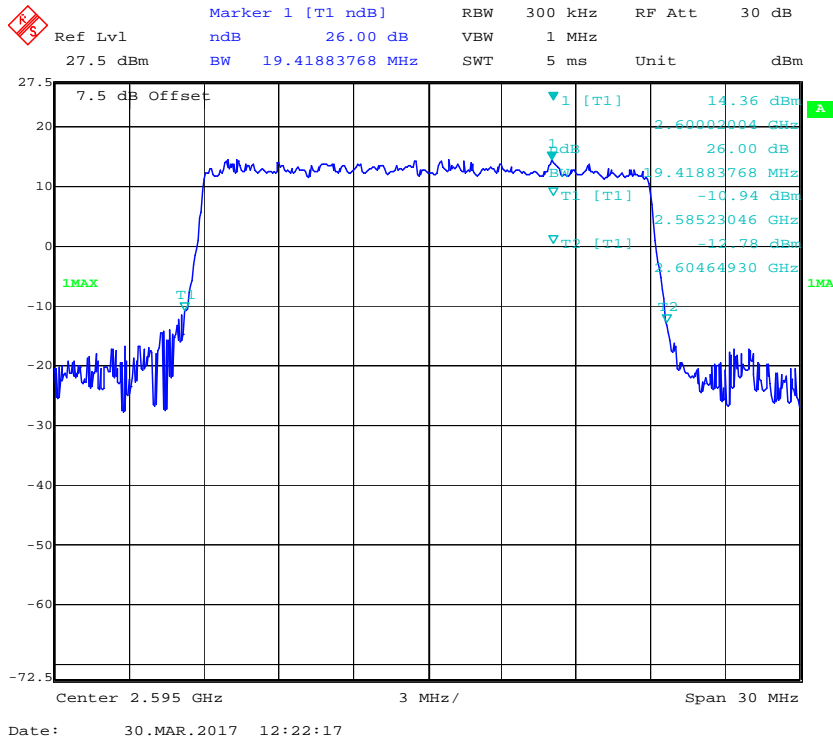

**16-QAM (20.0 MHz) - 26 dB Emissions Bandwidth, Middle channel**

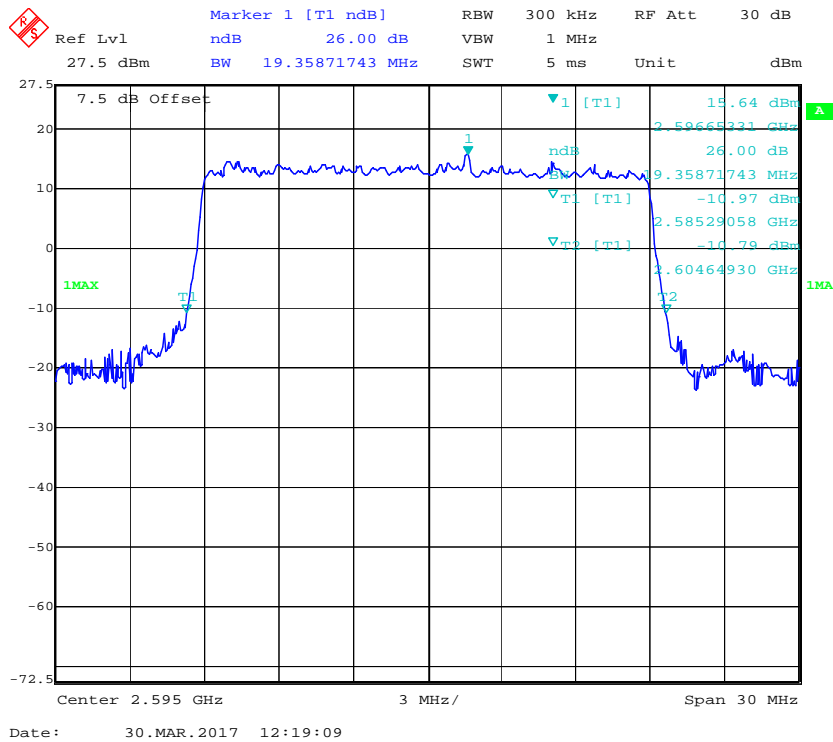

**LTE BAND 41:**

<b>Bandwidth (MHz)</b>	<b>Modulation</b>	<b>99% Occupied Bandwidth (MHz)</b>	<b>26 dB Emission Bandwidth (MHz)</b>
5.0	QPSK	4.509	5.030
	16QAM	4.509	4.950
10.0	QPSK	8.978	9.860
	16QAM	8.938	9.619
15.0	QPSK	13.527	15.391
	16QAM	13.527	15.030
20.0	QPSK	17.956	19.158
	16QAM	17.956	19.639



**QPSK (5.0 MHz) - 99% Occupied Bandwidth, Middle channel**

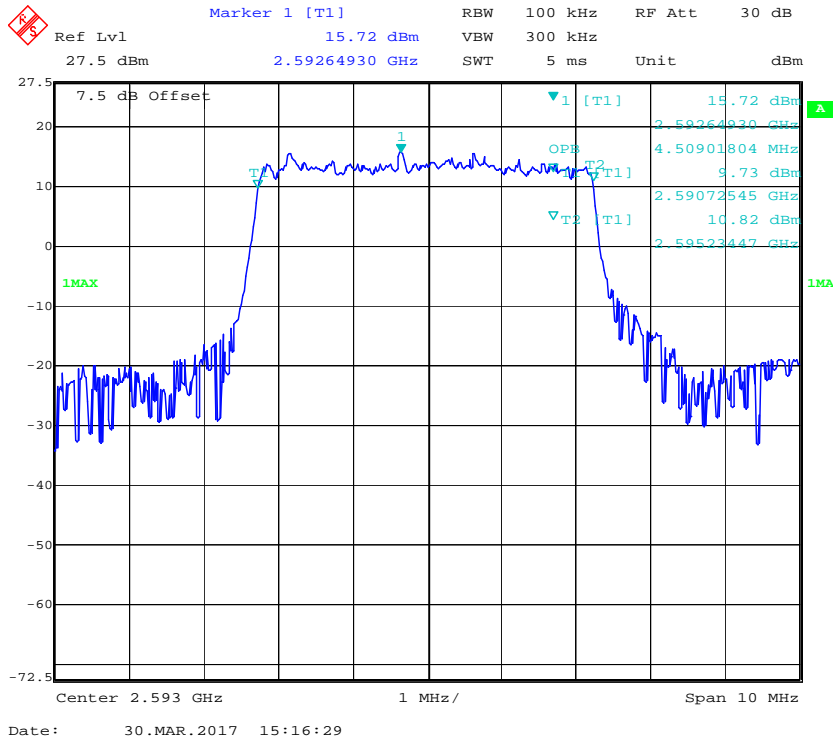

**16-QAM (5.0 MHz) - 99% Occupied Bandwidth, Middle channel**

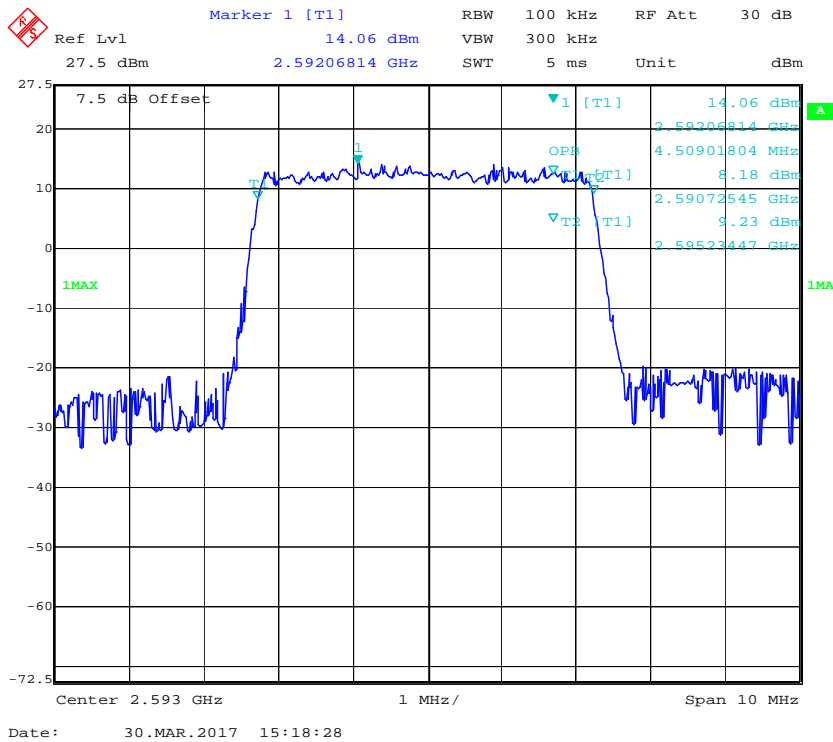

**QPSK (10.0 MHz) - 99% Occupied Bandwidth, Middle channel**

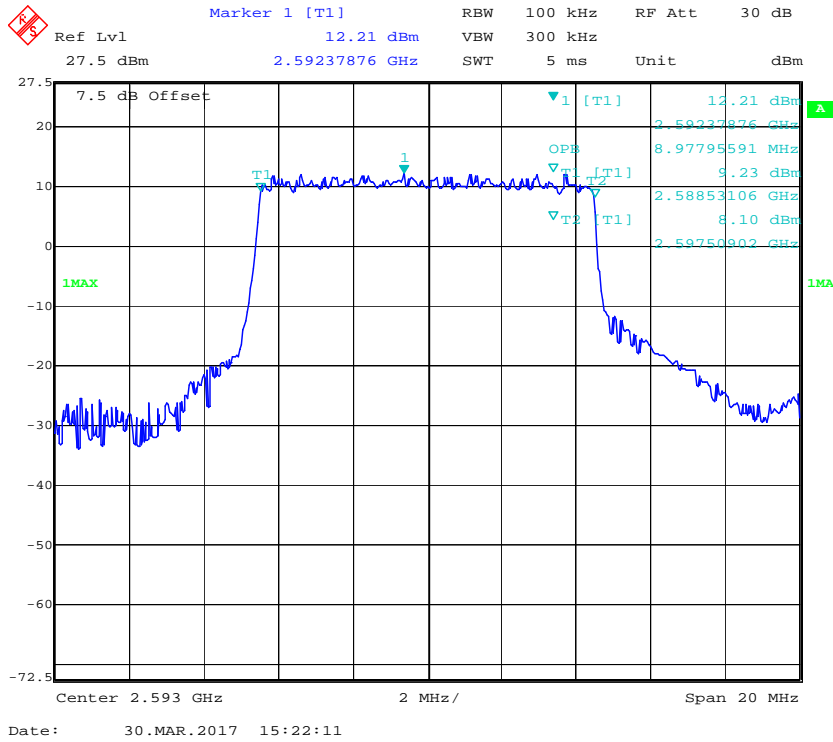

**16-QAM (10.0 MHz) - 99% Occupied Bandwidth, Middle channel**

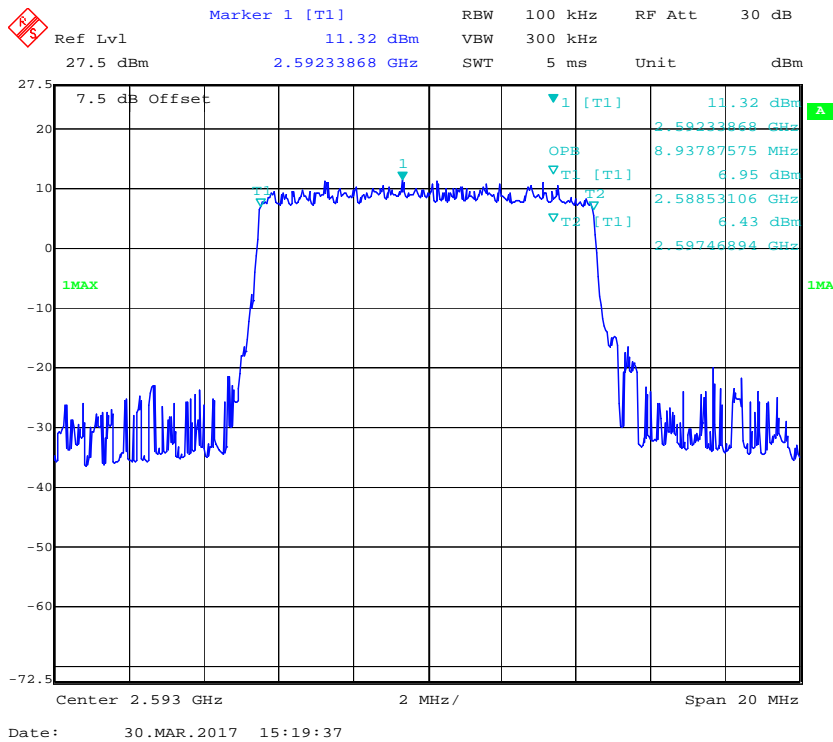

**QPSK (15.0 MHz) - 99% Occupied Bandwidth, Middle channel**

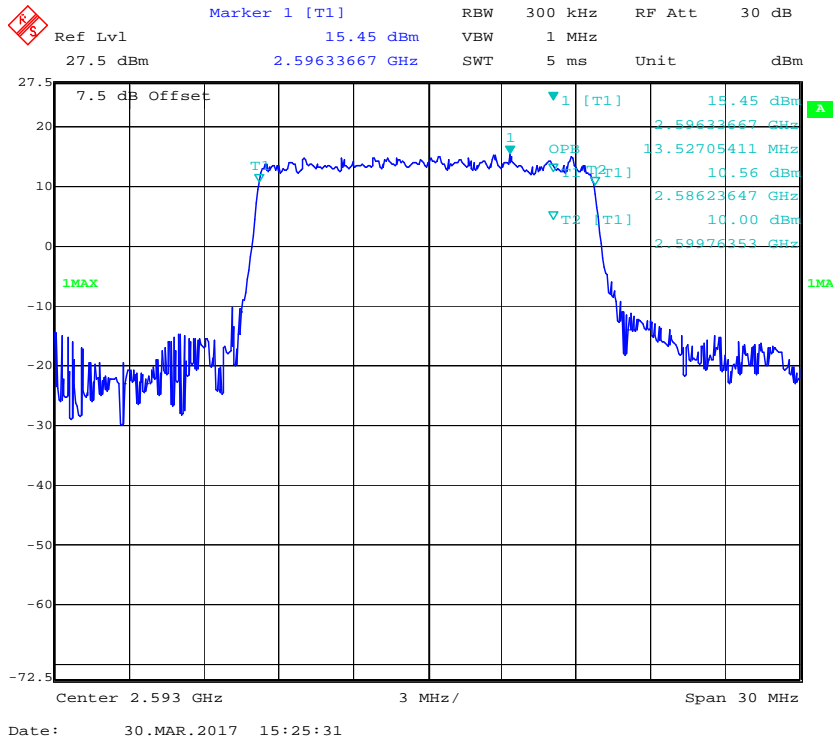

**16-QAM (15.0 MHz) - 99% Occupied Bandwidth, Middle channel**

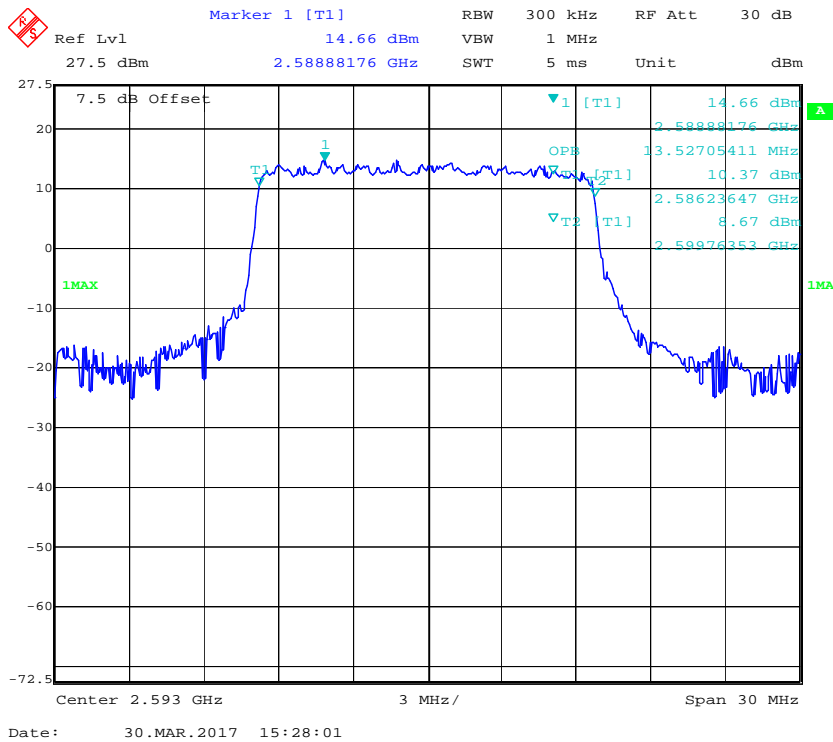

**QPSK (20.0 MHz) - 99% Occupied Bandwidth, Middle channel**

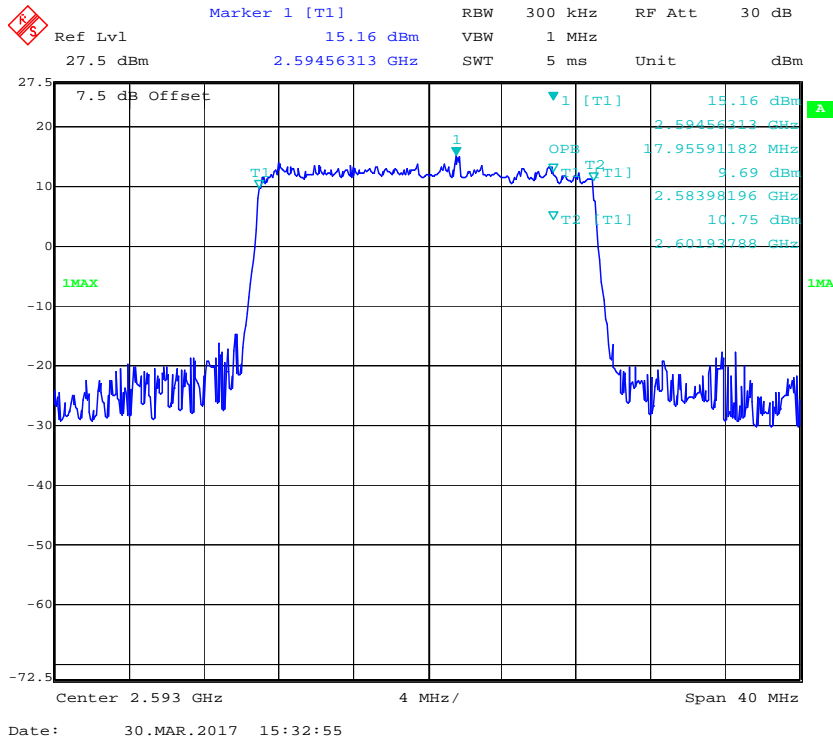

**16-QAM (20.0 MHz) - 99% Occupied Bandwidth, Middle channel**

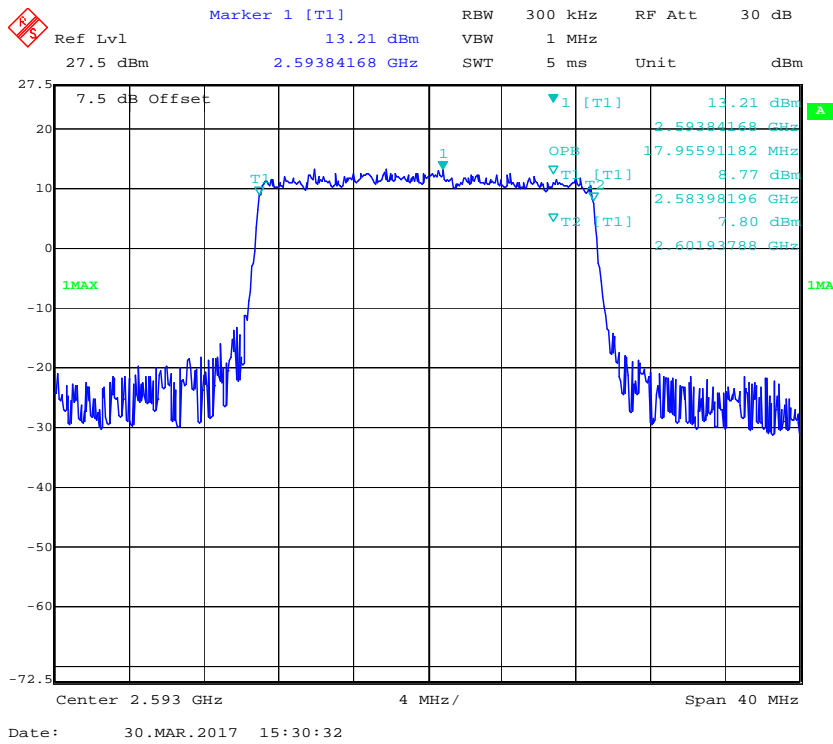

**QPSK (5.0 MHz) - 26 dB Emissions Bandwidth, Middle channel**

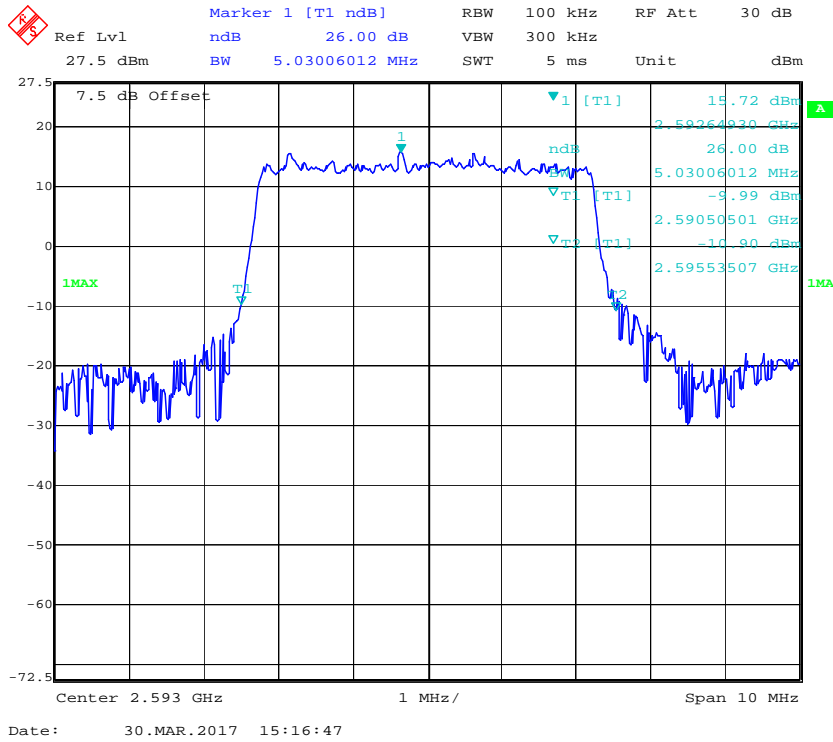

**16-QAM (5.0 MHz) - 26 dB Emissions Bandwidth, Middle channel**

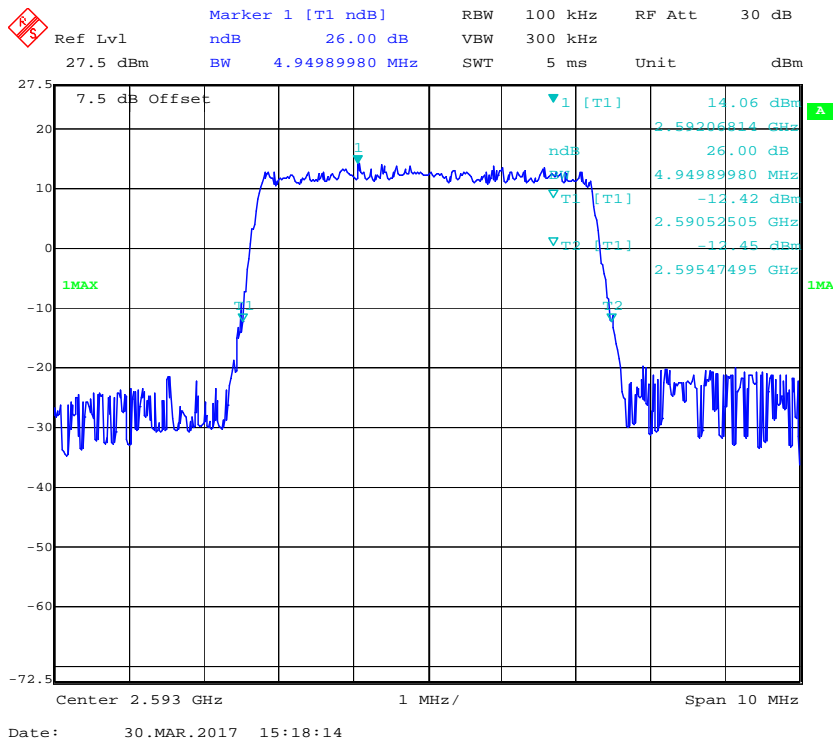

**QPSK (10.0 MHz) - 26 dB Emissions Bandwidth, Middle channel**

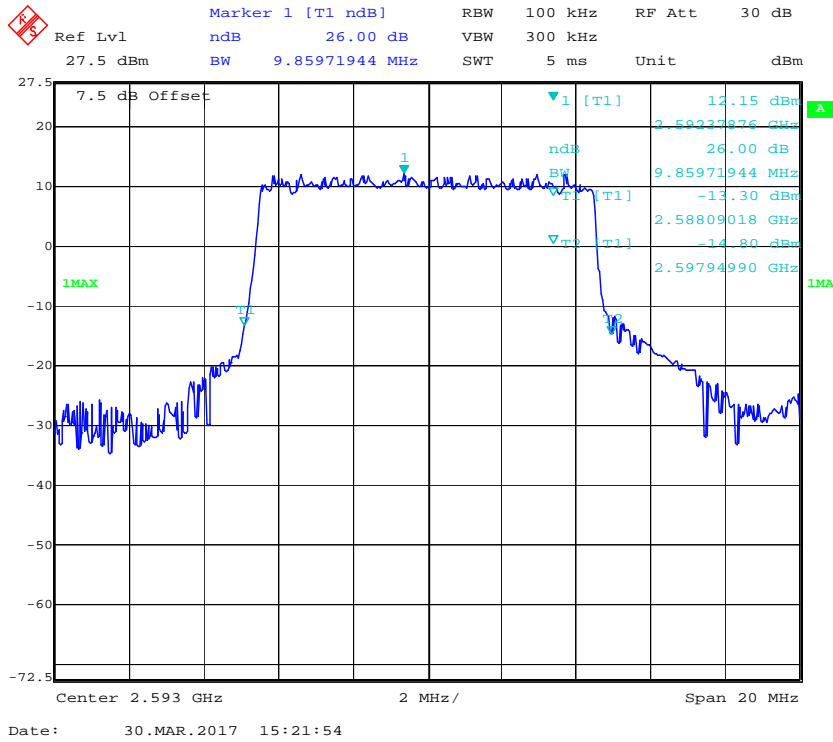

**16-QAM (10.0 MHz) - 26 dB Emissions Bandwidth, Middle channel**

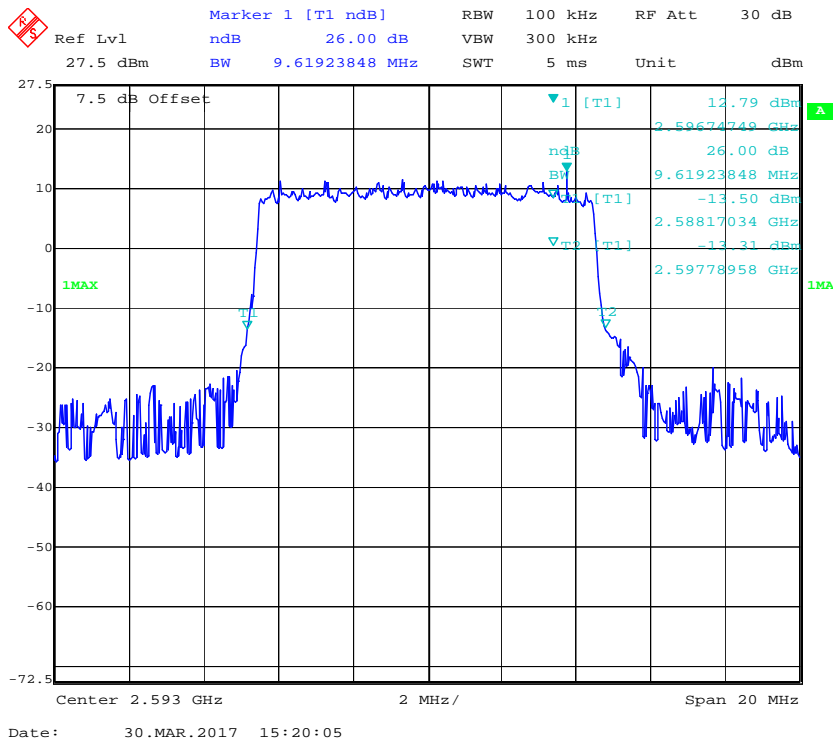

**QPSK (15.0 MHz) - 26 dB Emissions Bandwidth, Middle channel**

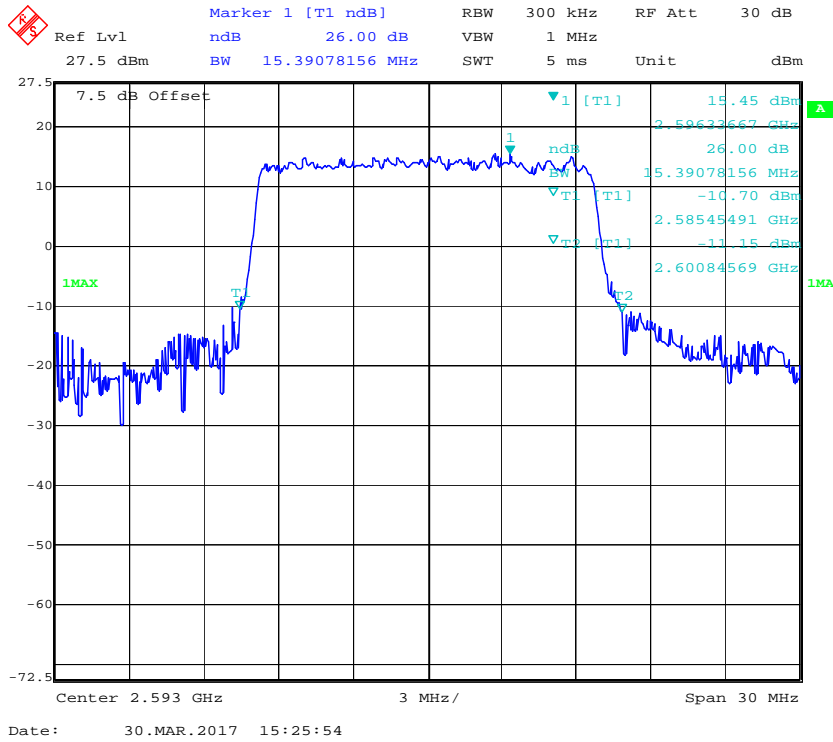

**16-QAM (15.0 MHz) - 26 dB Emissions Bandwidth, Middle channel**

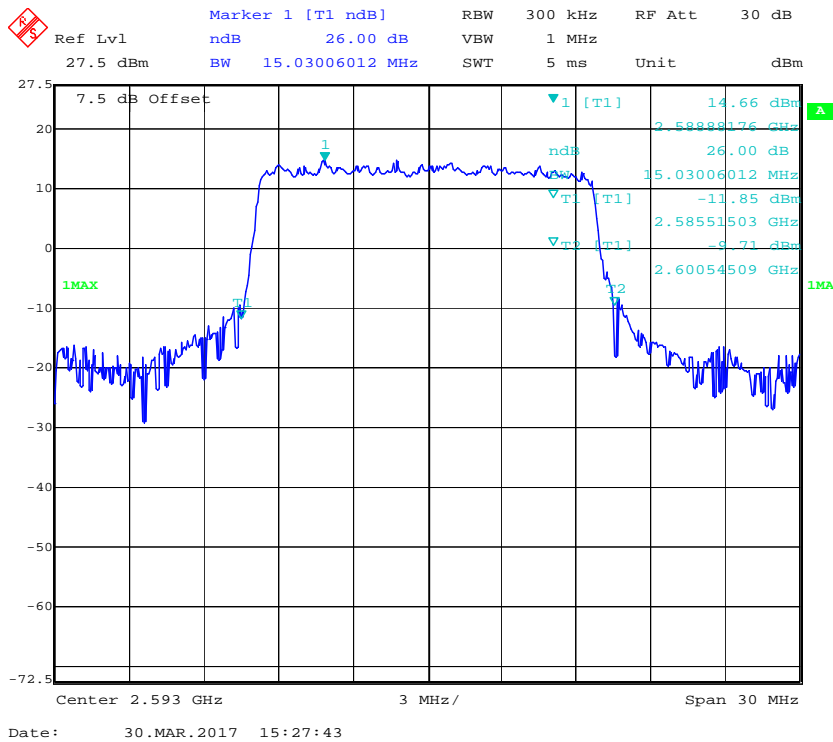

**QPSK (20.0 MHz) - 26 dB Emissions Bandwidth, Middle channel**

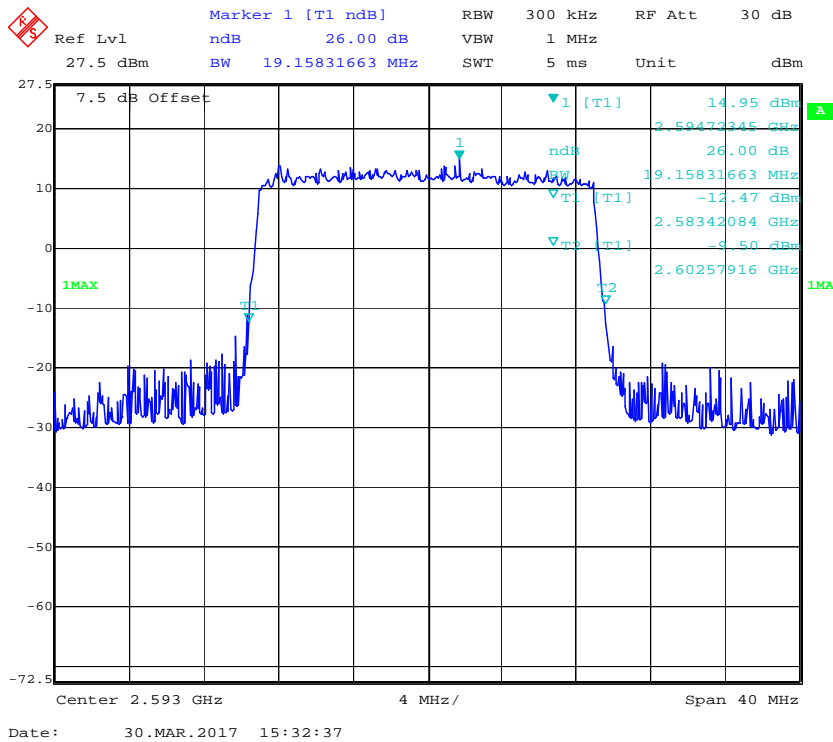

**16-QAM (20.0 MHz) - 26 dB Emissions Bandwidth, Middle channel**

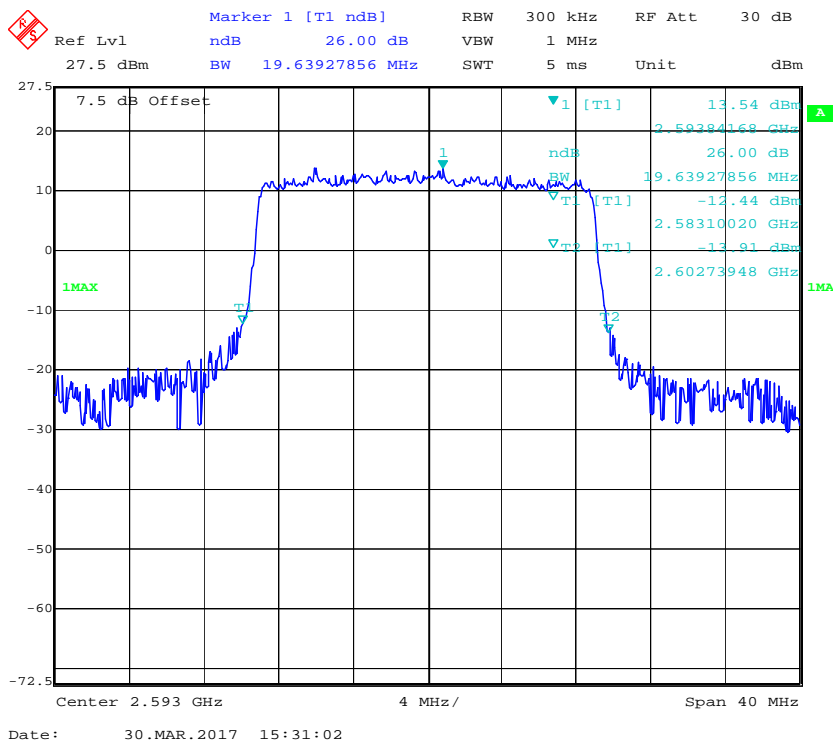



**FCC §2.1051, §22.917(a) & §24.238(a); §27.53(a) (h) (m); §90.691 - SPURIOUS EMISSIONS AT ANTENNA TERMINALS**

**Applicable Standard**

FCC §2.1051, §22.917(a) and §24.238(a) and §27.53(a) (h) (m) and §90.691.

The spectrum was to be investigated to the tenth harmonics of the highest fundamental frequency as specified in § 2.1051.

**Test Procedure**

The RF output of the transceiver was connected to a spectrum analyzer and simulator through appropriate attenuation. The resolution bandwidth of the spectrum analyzer was set at 1MHz. Sufficient scans were taken to show any out of band emissions up to 10<sup>th</sup> harmonic.

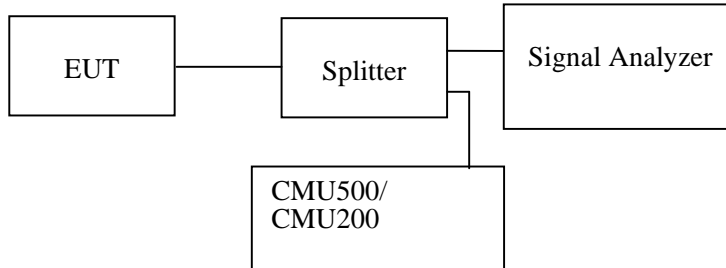

**Test Data**

**Environmental Conditions**

<b>Temperature:</b>	23~25 °C
<b>Relative Humidity:</b>	48~54 %
<b>ATM Pressure:</b>	100.0~101.0 kPa

The testing was performed by Nefertari Xu from 2017-03-16 to 2017-05-24.

*EUT operation mode: Transmitting*

*Test result: Compliance, please refer to the following plots.*

Cellular Band (Part 22H)

30 MHz – 1 GHz (GSM Mode)

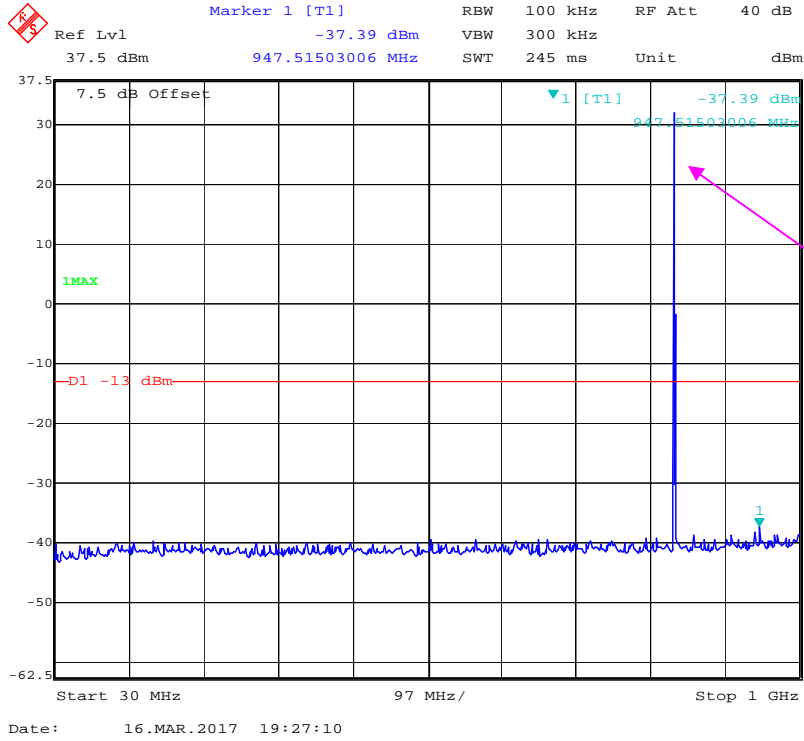

1 GHz – 10 GHz (GSM Mode)

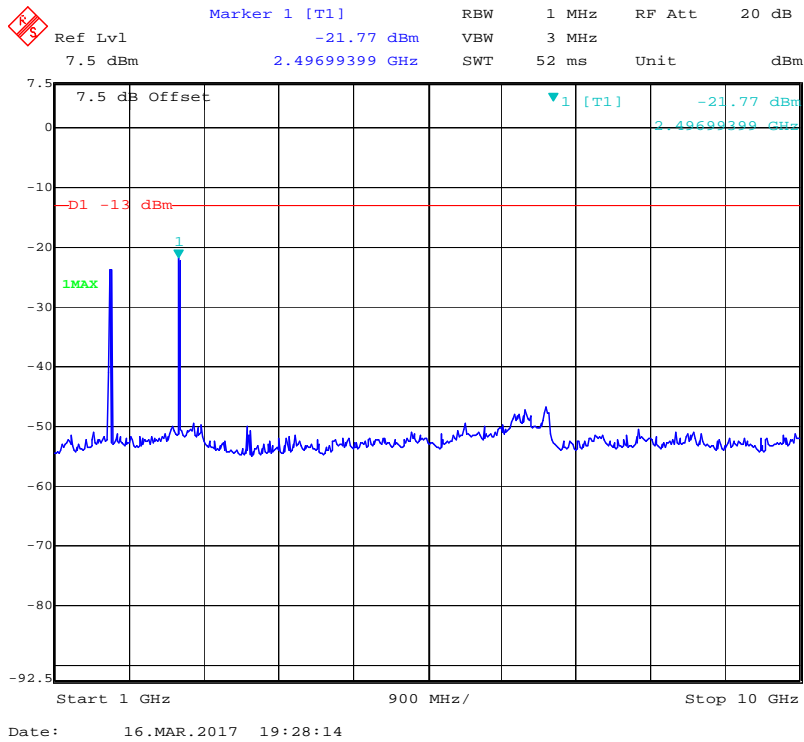

### 30 MHz – 1 GHz CDMA Mode

**Marker 1 [T1]**  
Ref Lvl 35.5 dBm      -39.19 dBm      RBW 100 kHz      RF Att 40 dB  
966.95390782 MHz      VBW 300 kHz  
SWT 245 ms      Unit dBm

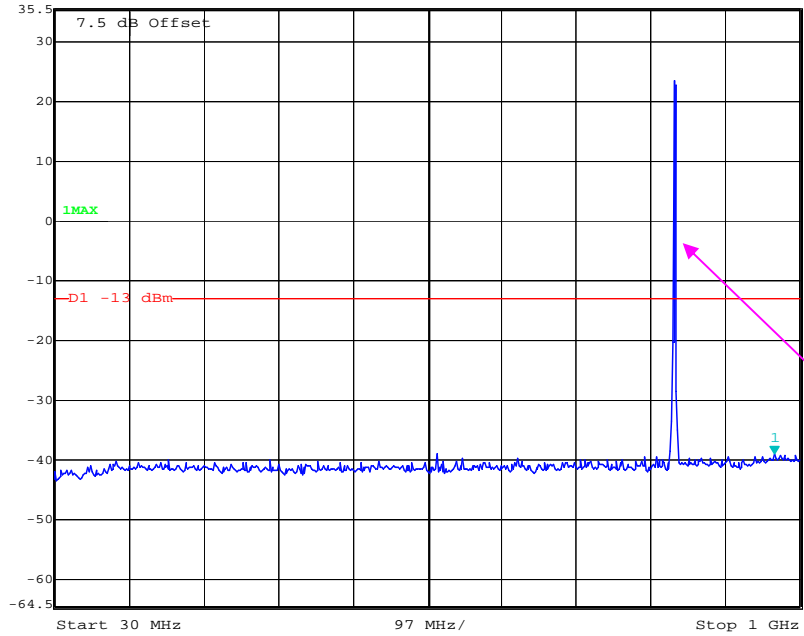

Date: 16.MAY.2017 14:28:09

### 1 GHz – 10 GHz CDMA Mode

**Marker 1 [T1]**  
Ref Lvl 17.5 dBm      -33.68 dBm      RBW 1 MHz      RF Att 20 dB  
1.66733467 GHz      VBW 3 MHz  
SWT 52 ms      Unit dBm

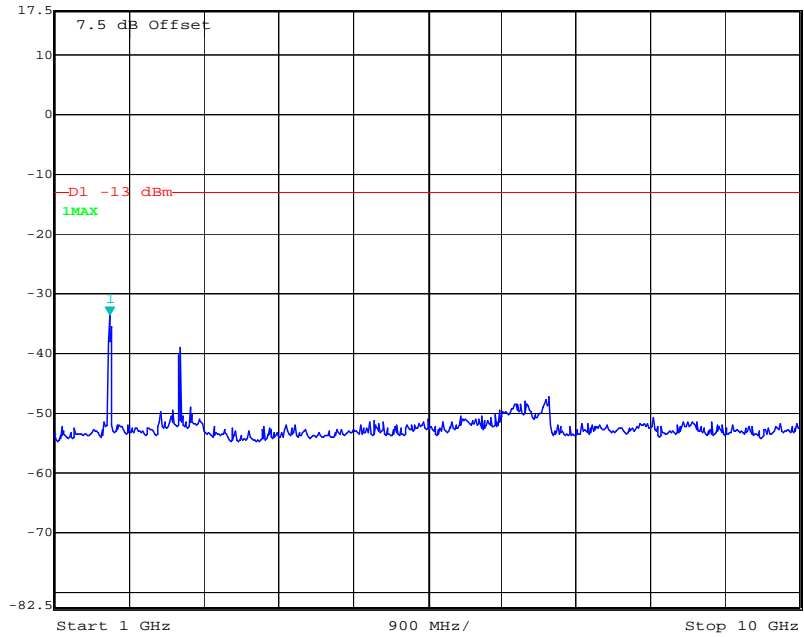

Date: 16.MAY.2017 14:29:27



PCS Band (Part 24E)

30 MHz – 1 GHz (GSM Mode)

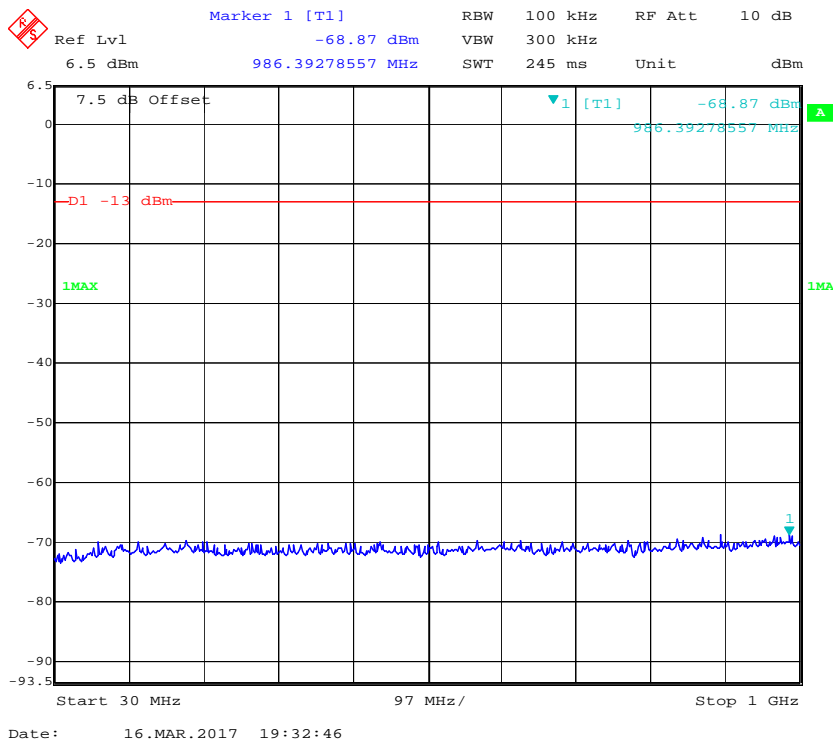

1 GHz – 20 GHz (GSM Mode)

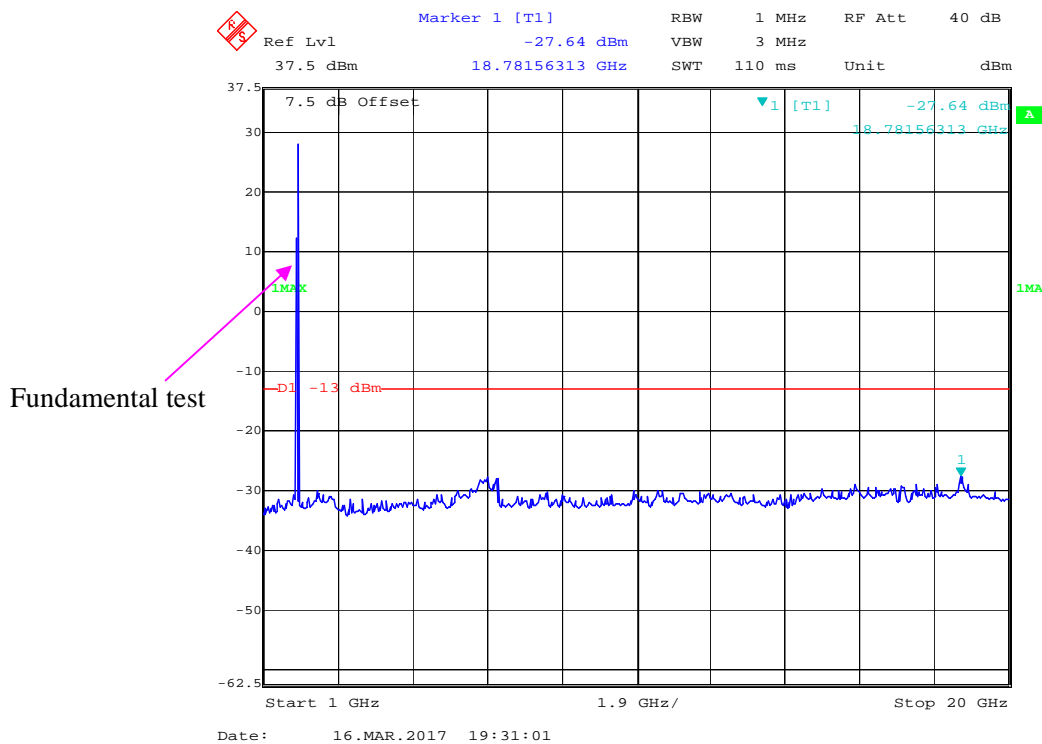

LTE Band 2:

30 MHz - 1 GHz (1.4 MHz, Middle Channel)

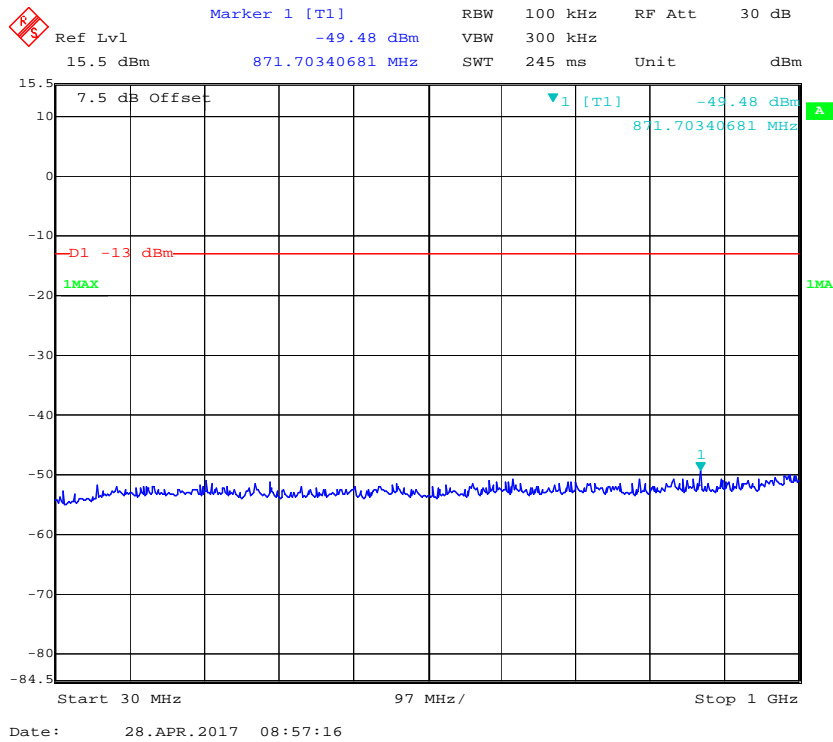

1 GHz - 20 GHz (1.4 MHz, Middle Channel)

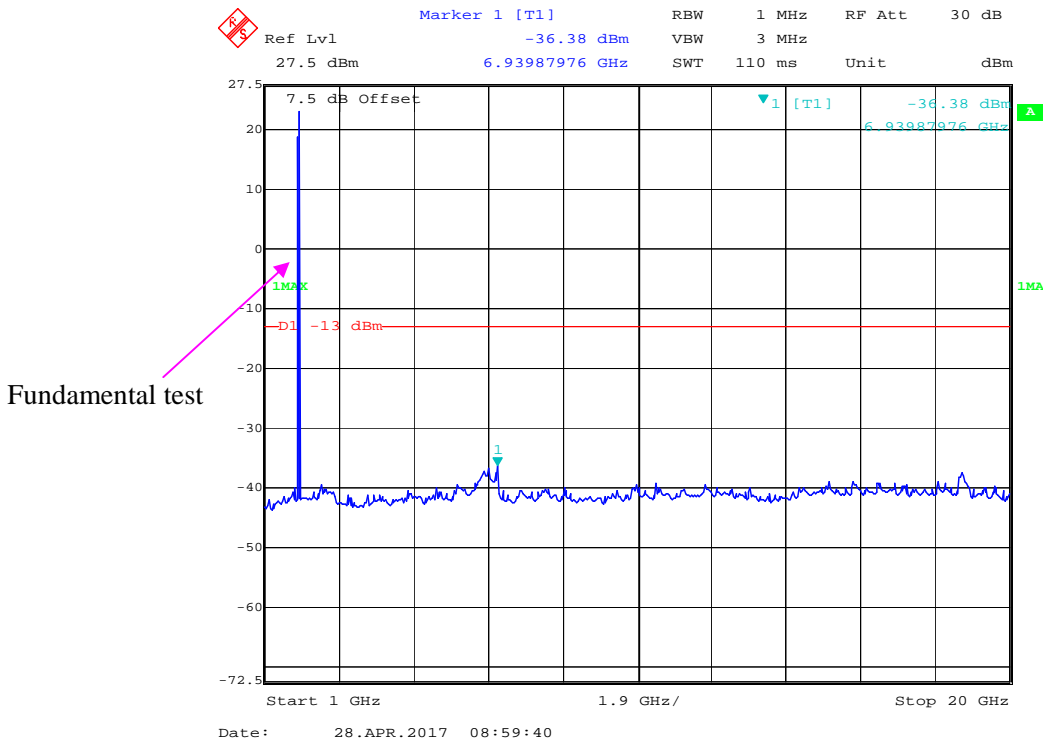

### 30 MHz - 1 GHz (3.0 MHz, Middle Channel)

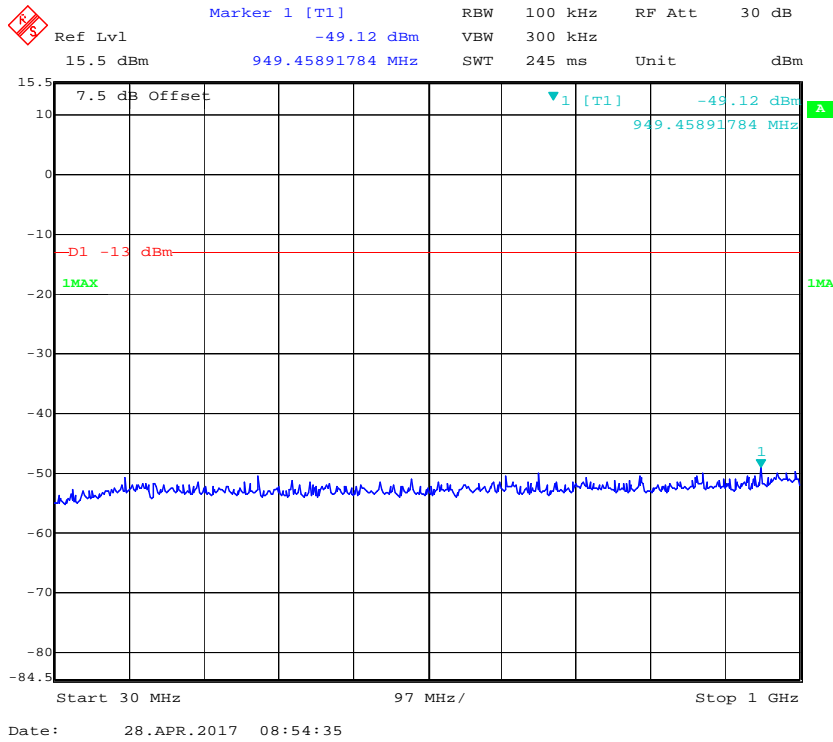

### 1 GHz - 20 GHz (3.0 MHz, Middle Channel)

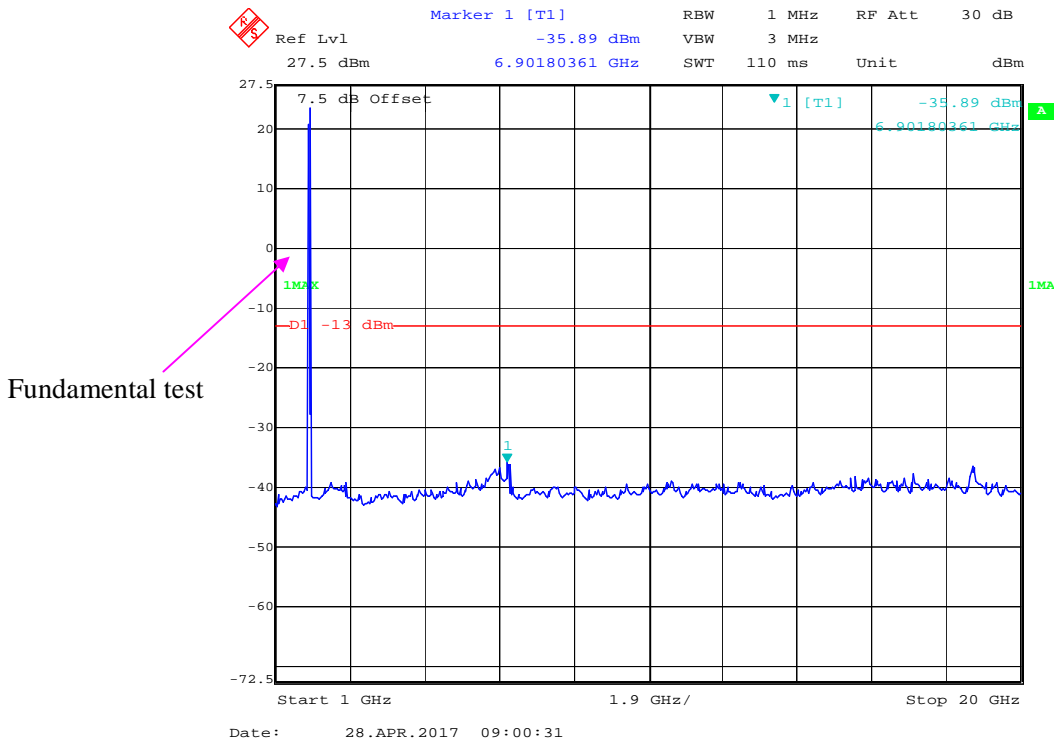

### 30 MHz - 1 GHz (5.0 MHz, Middle Channel)

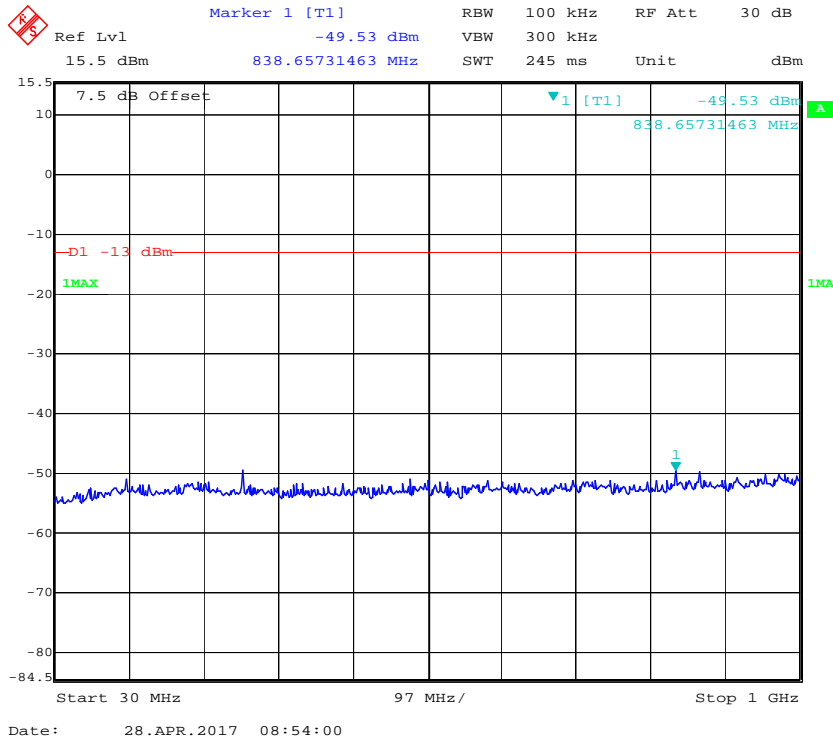

### 1 GHz - 20 GHz (5.0 MHz, Middle Channel)

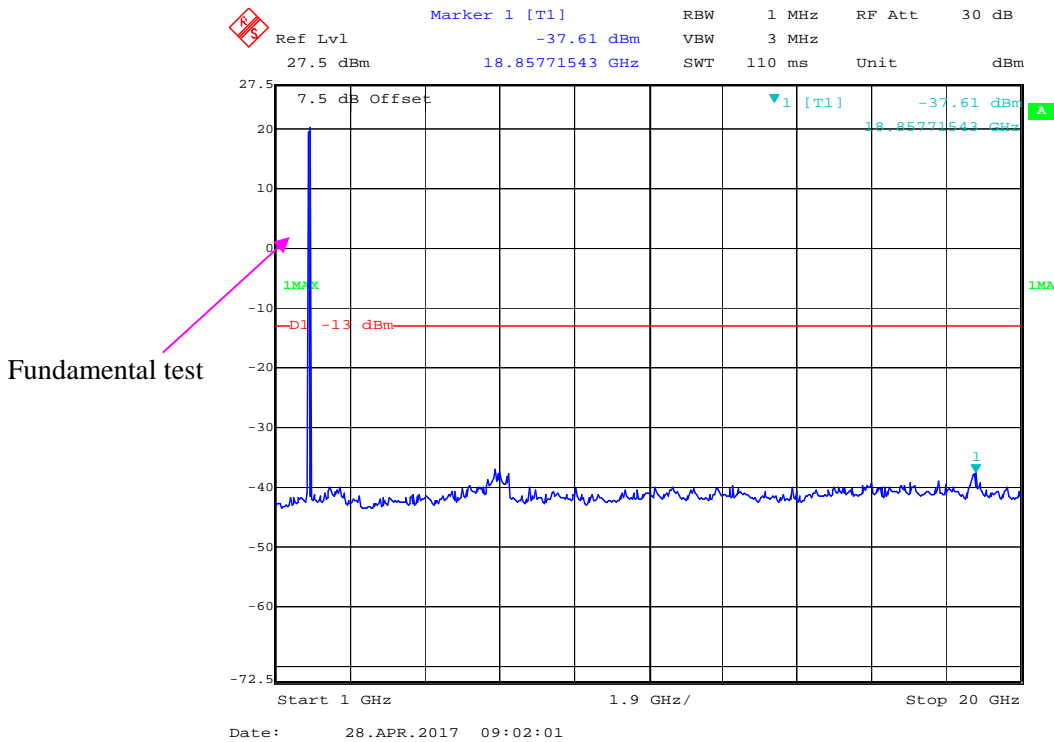



30 MHz - 1 GHz (10.0 MHz, Middle Channel)

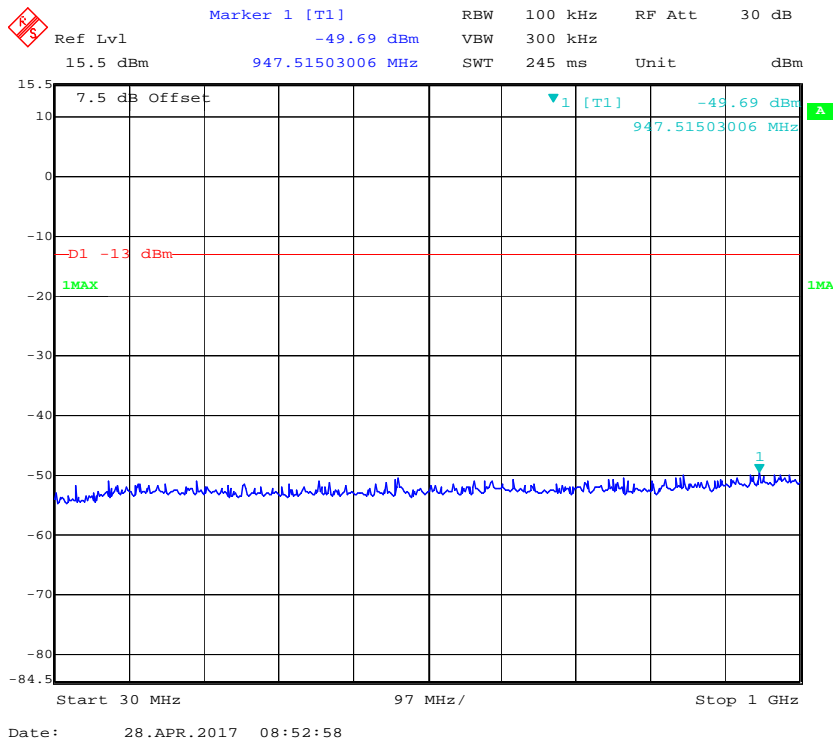

1 GHz - 20 GHz (10.0 MHz, Middle Channel)

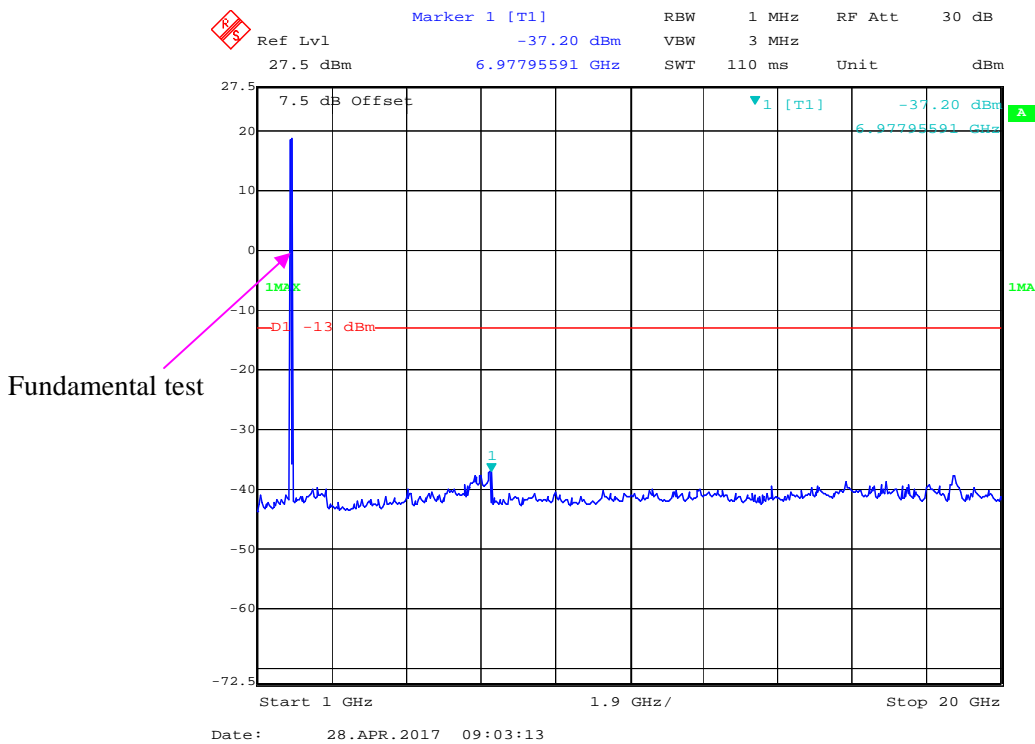

### 30 MHz - 1 GHz (15.0 MHz, Middle Channel)

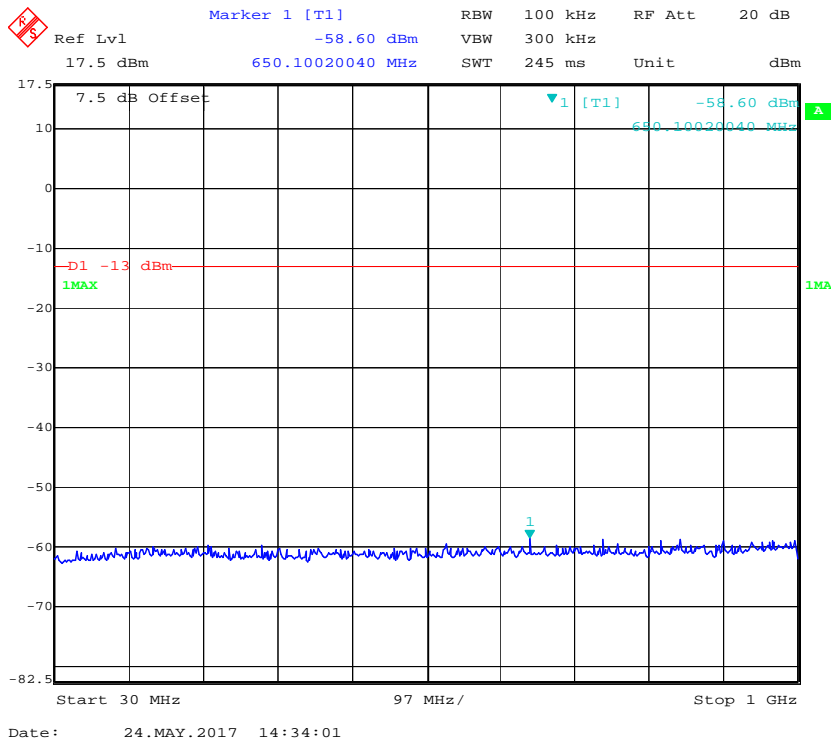

### 1 GHz - 20 GHz (15.0 MHz, Middle Channel)

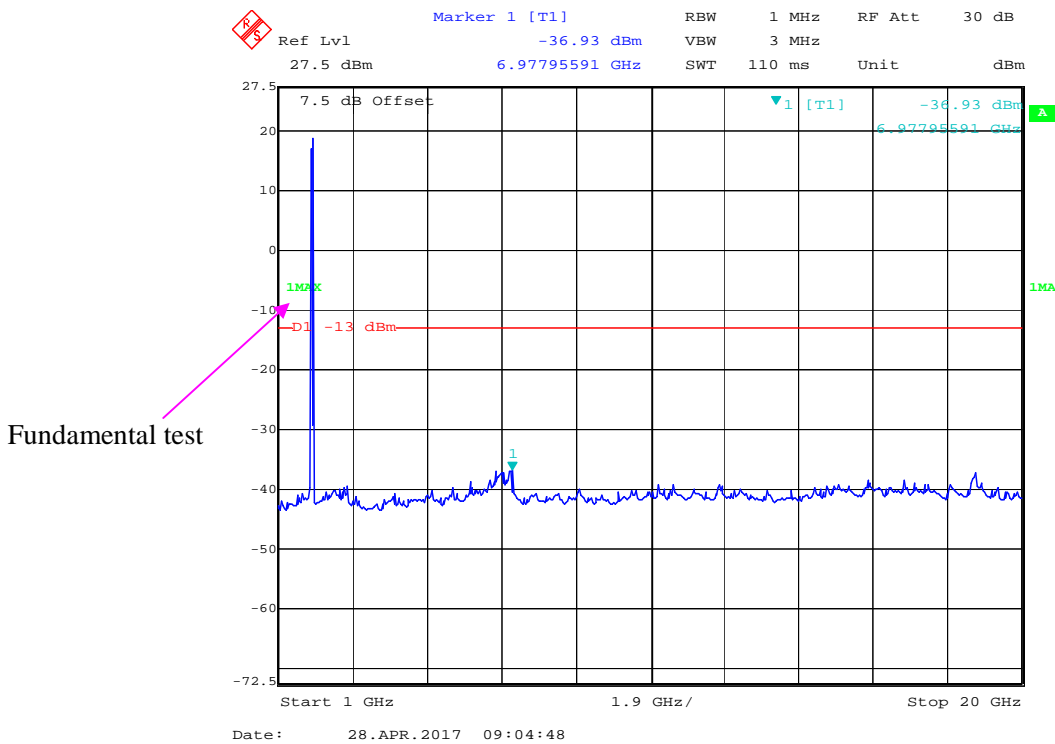

**30 MHz - 1 GHz (20.0 MHz, Middle Channel)**

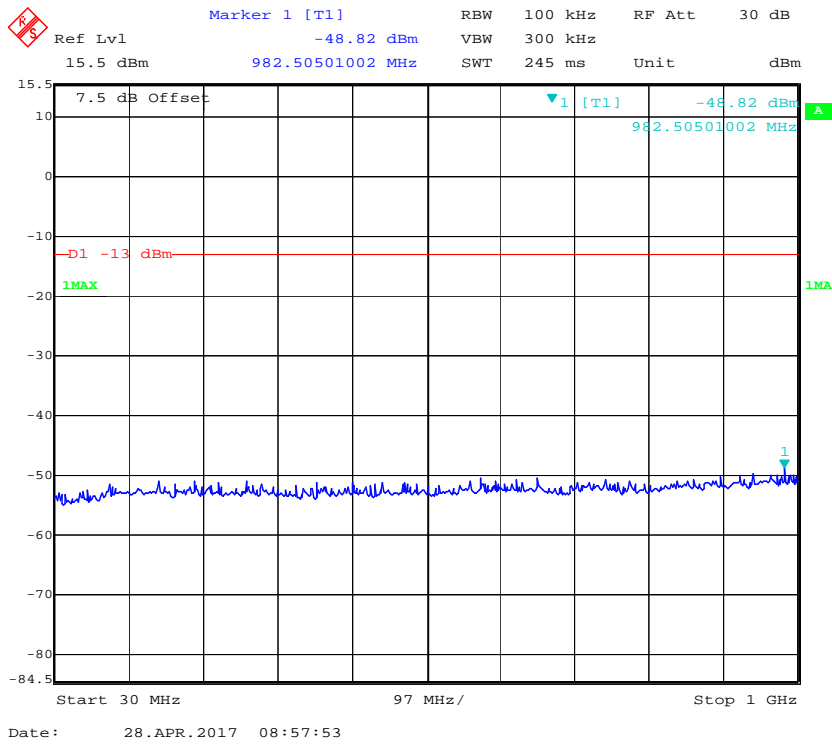

**1 GHz - 2 GHz (20.0 MHz, Middle Channel)**

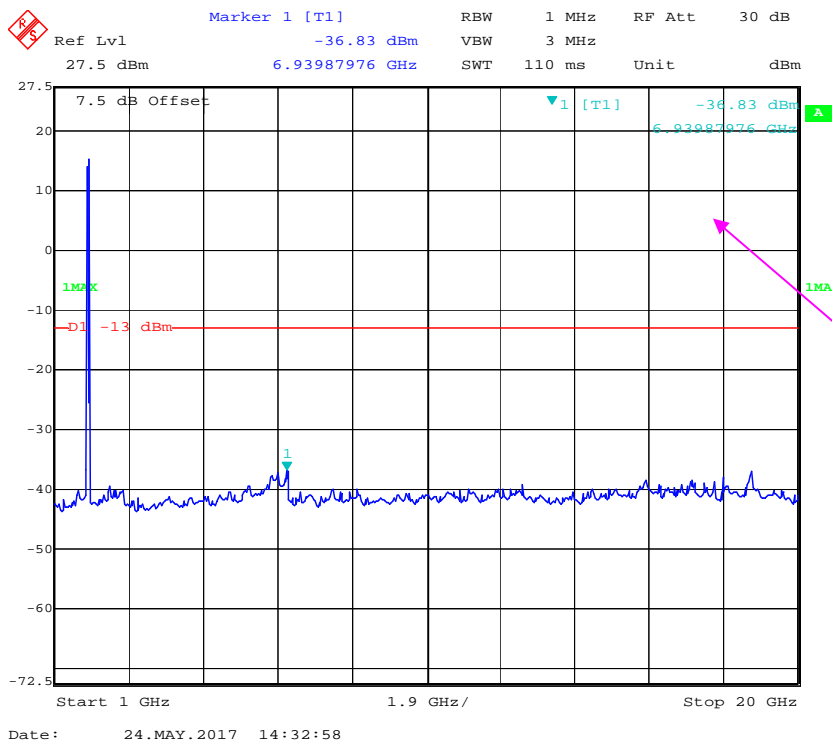

LTE Band 4:

30 MHz - 1 GHz (1.4 MHz, Middle Channel)

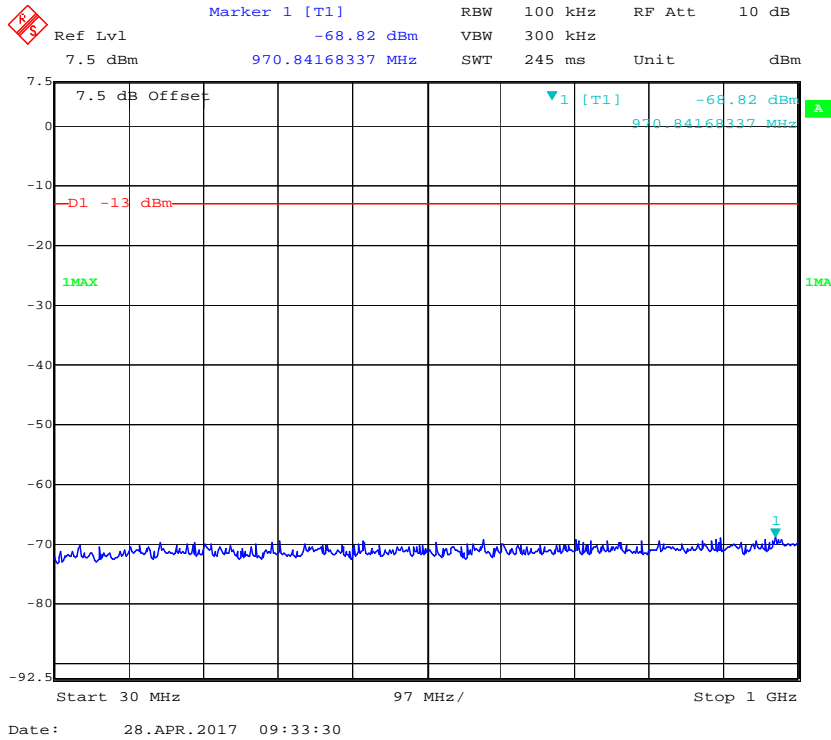

1 GHz - 20 GHz (1.4 MHz, Middle Channel)

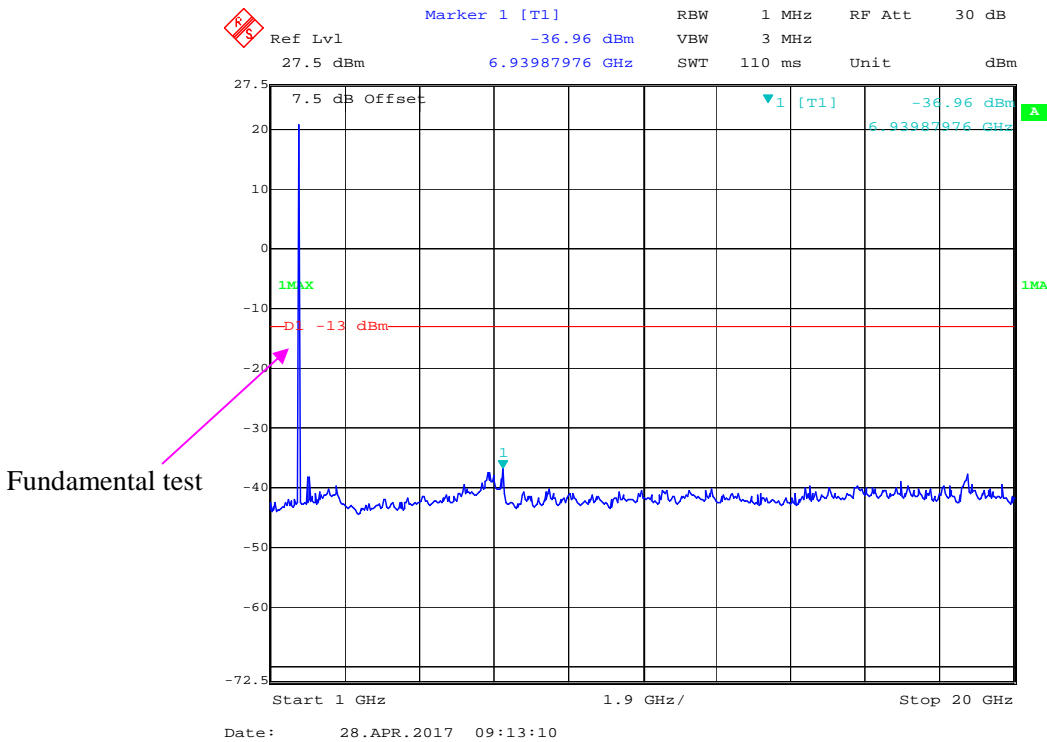

### 30 MHz - 1 GHz (3.0 MHz, Middle Channel)

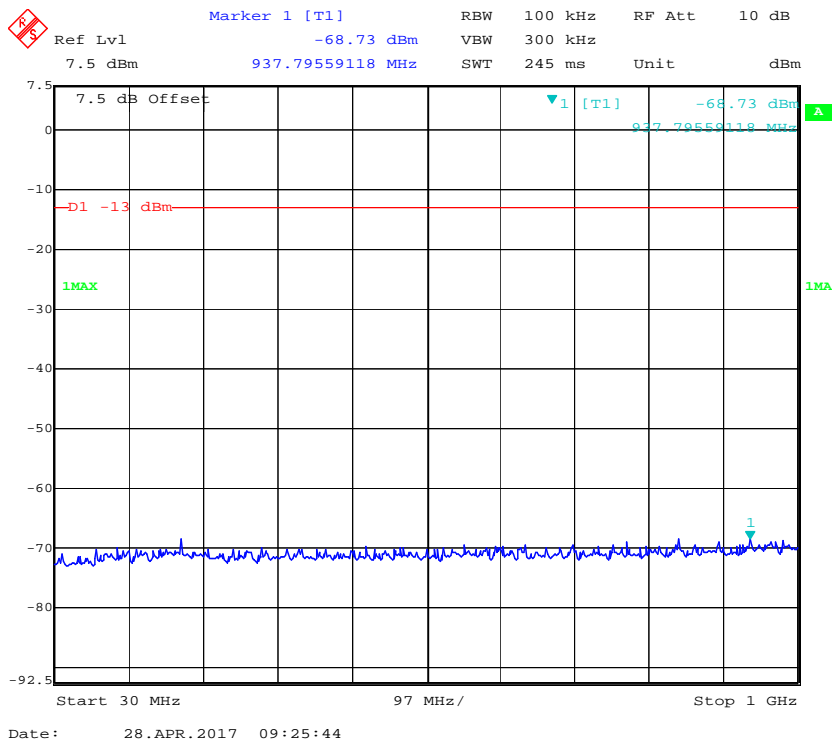

### 1 GHz - 20 GHz (3.0 MHz, Middle Channel)

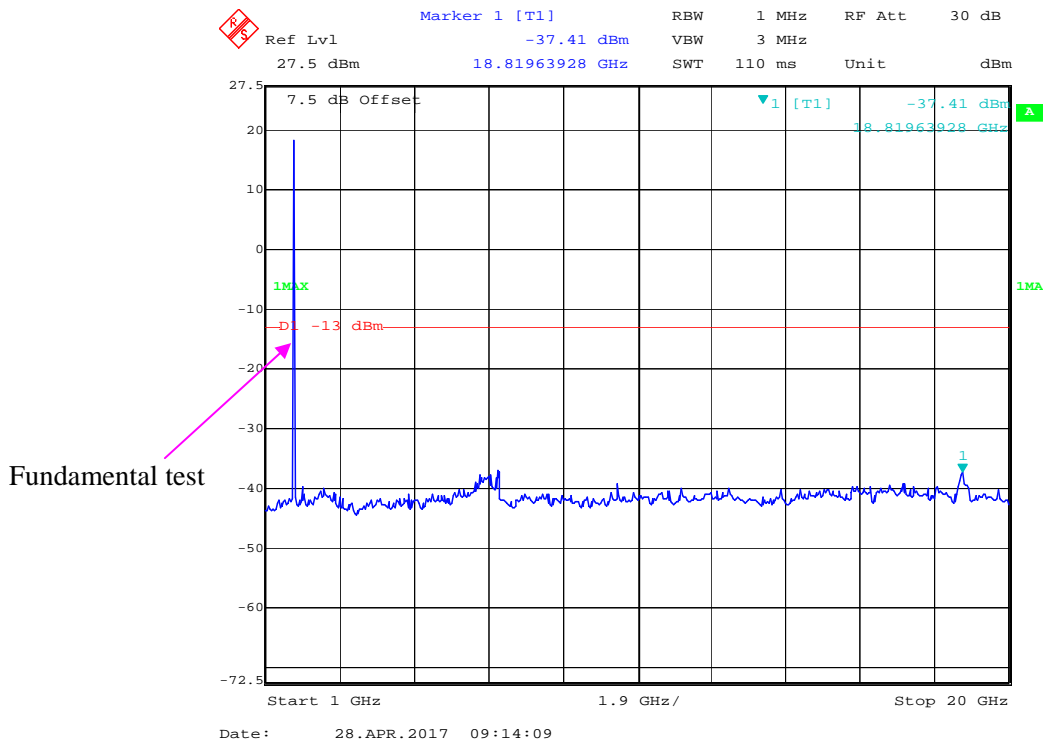



### 30 MHz - 1 GHz (10.0 MHz, Middle Channel)

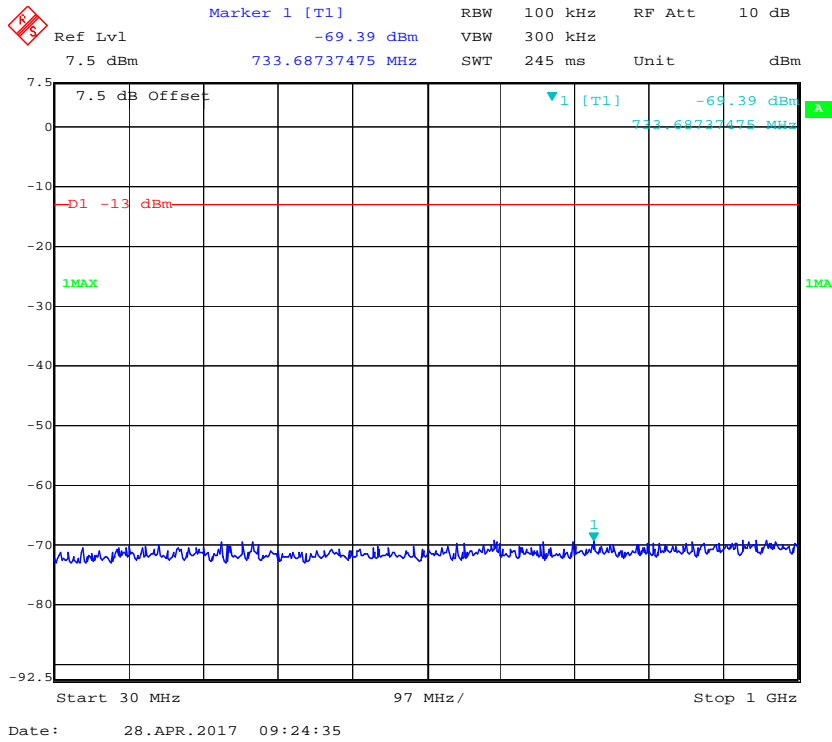

### 1 GHz - 20 GHz (10.0 MHz, Middle Channel)

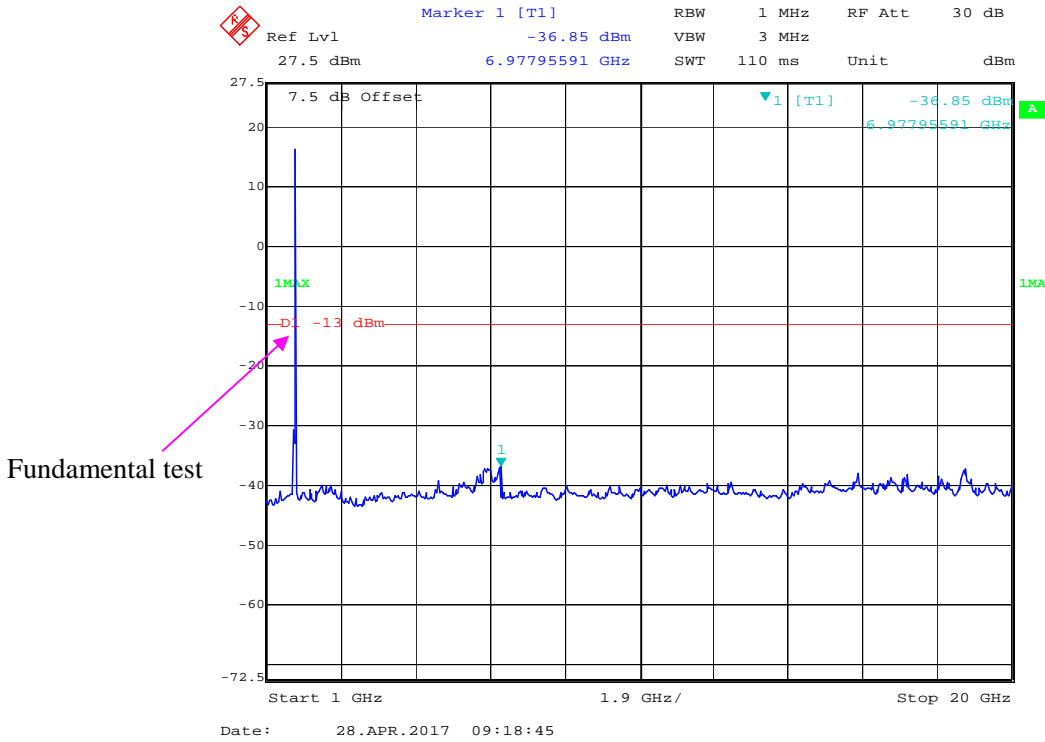





### 30 MHz - 1 GHz (20.0 MHz, Middle Channel)

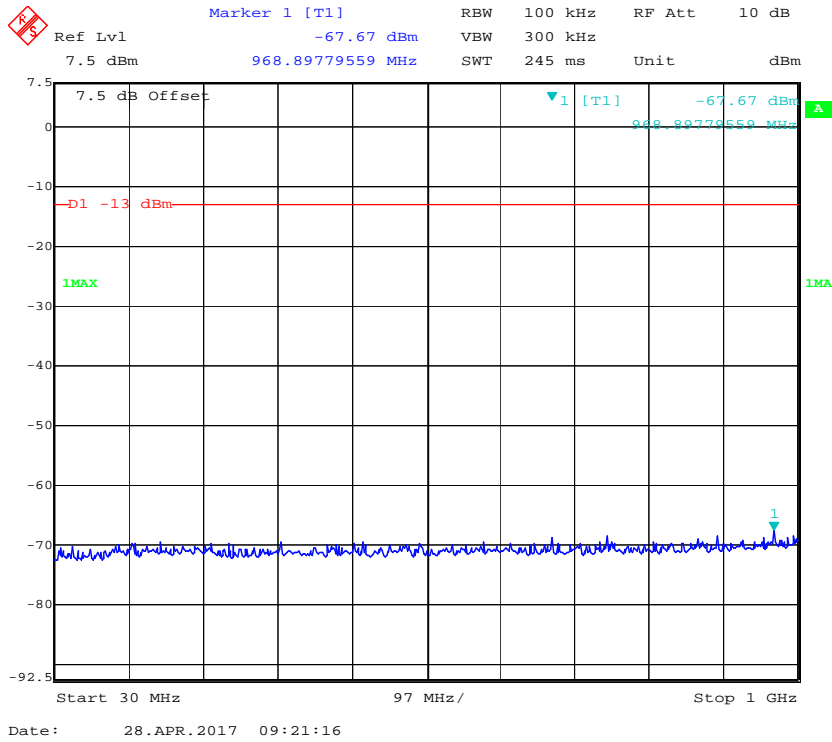

### 1 GHz - 20 GHz (20.0 MHz, Middle Channel)

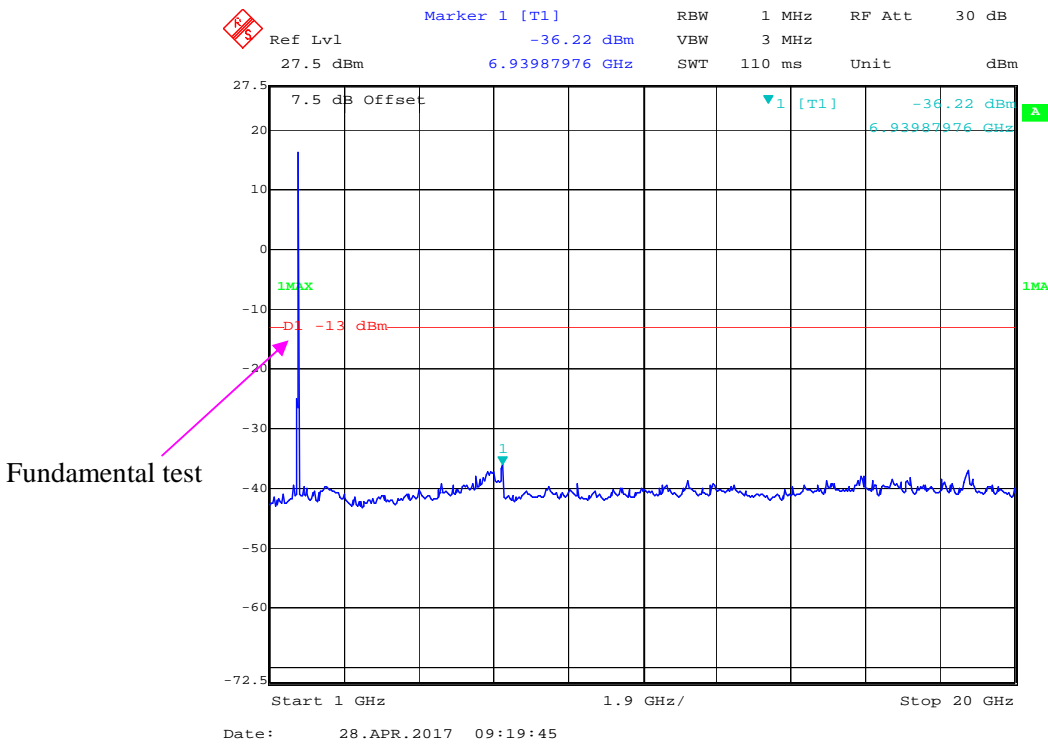

**LTE Band 5:**

**30 MHz - 1 GHz (1.4 MHz, Middle Channel)**

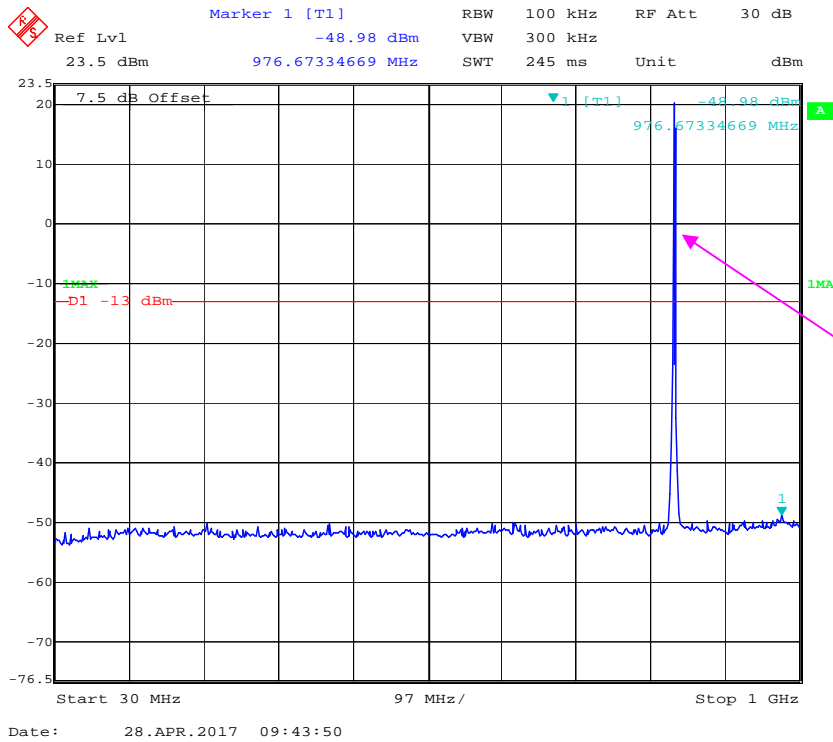

**1 GHz - 10 GHz (1.4 MHz, Middle Channel)**

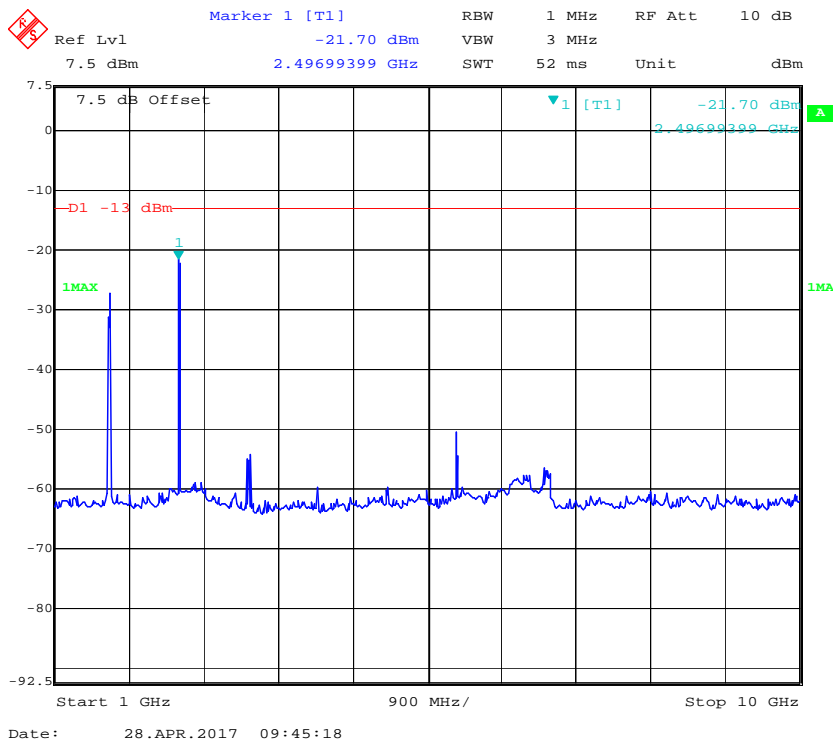

### 30 MHz - 1 GHz (3.0 MHz, Middle Channel)

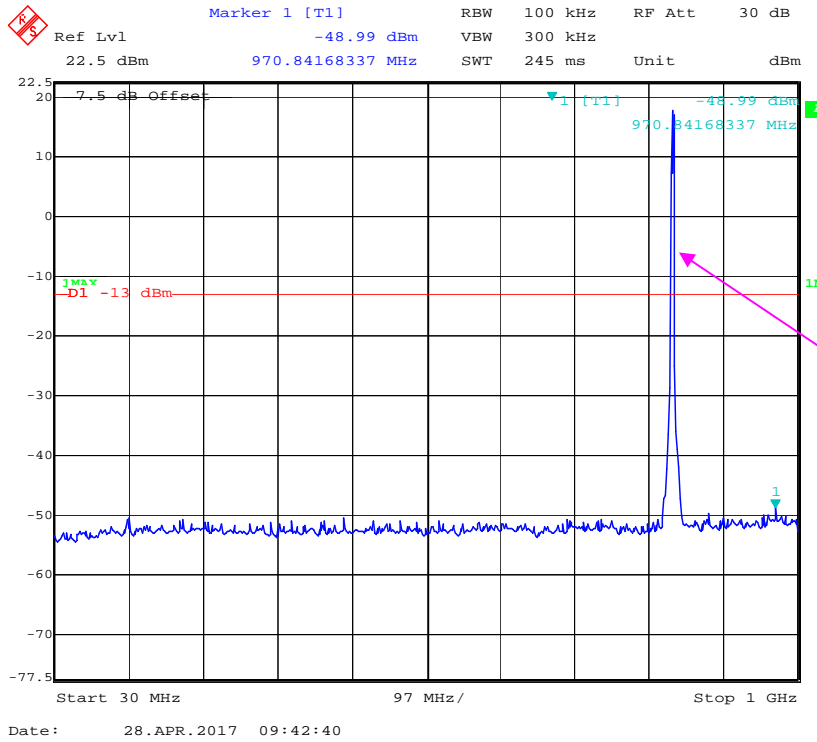

### 1 GHz - 10 GHz (3.0 MHz, Middle Channel)

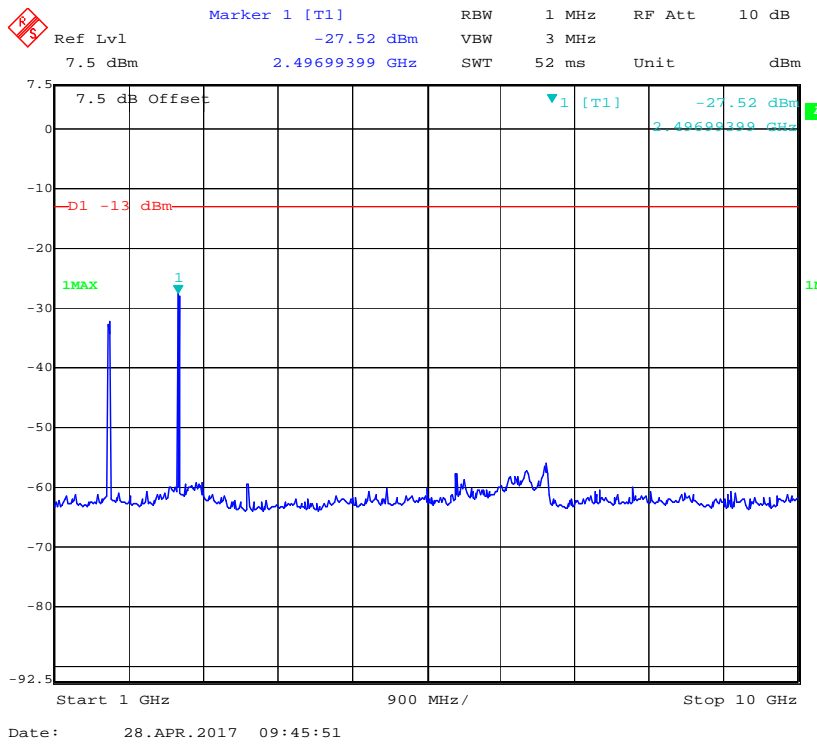

### 30 MHz - 1 GHz (5.0 MHz, Middle Channel)

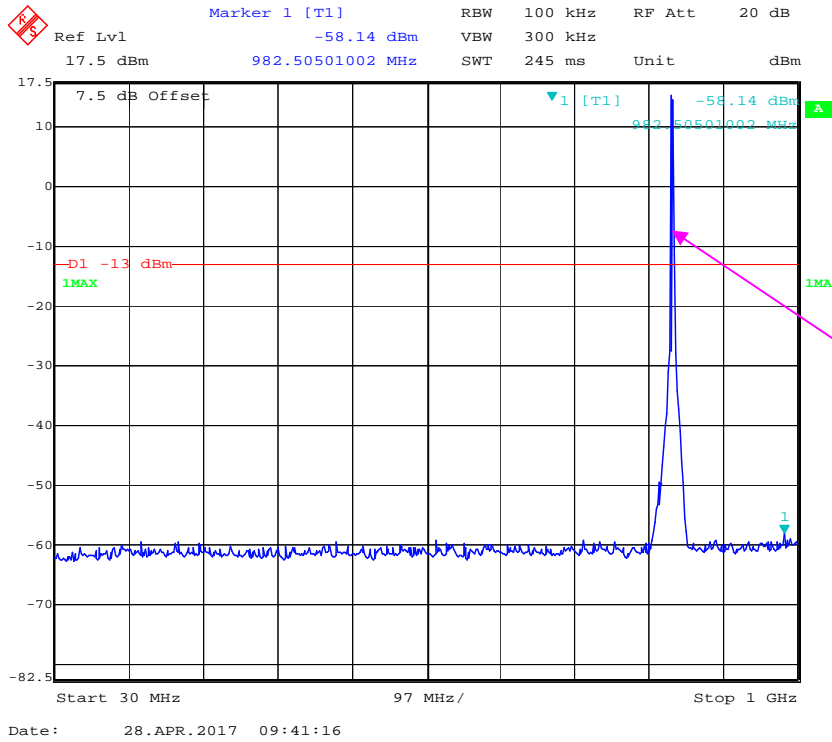

### 1 GHz - 10 GHz (5.0 MHz, Middle Channel)

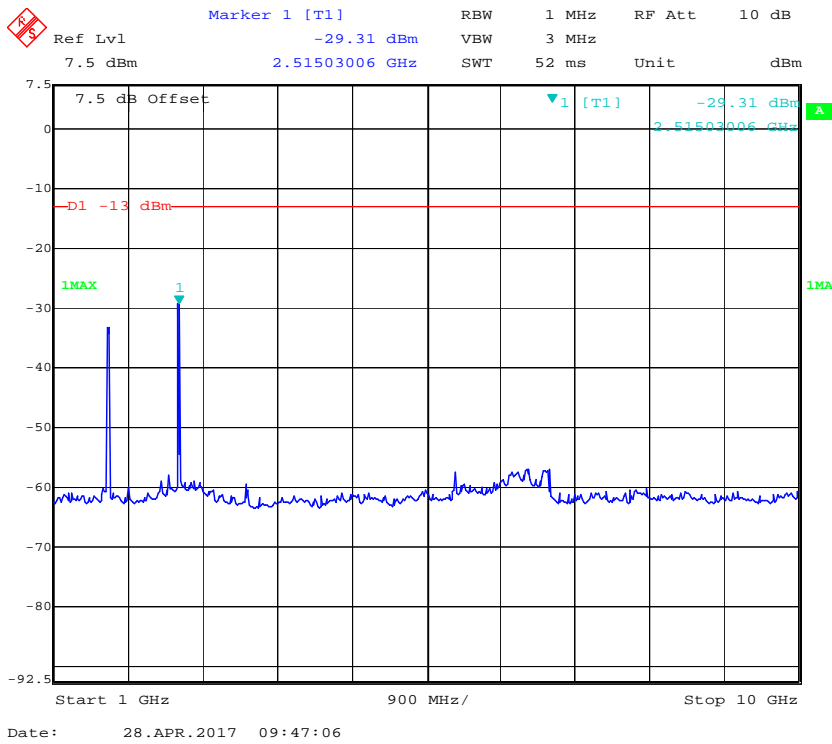

### 30 MHz - 1 GHz (10.0 MHz, Middle Channel)

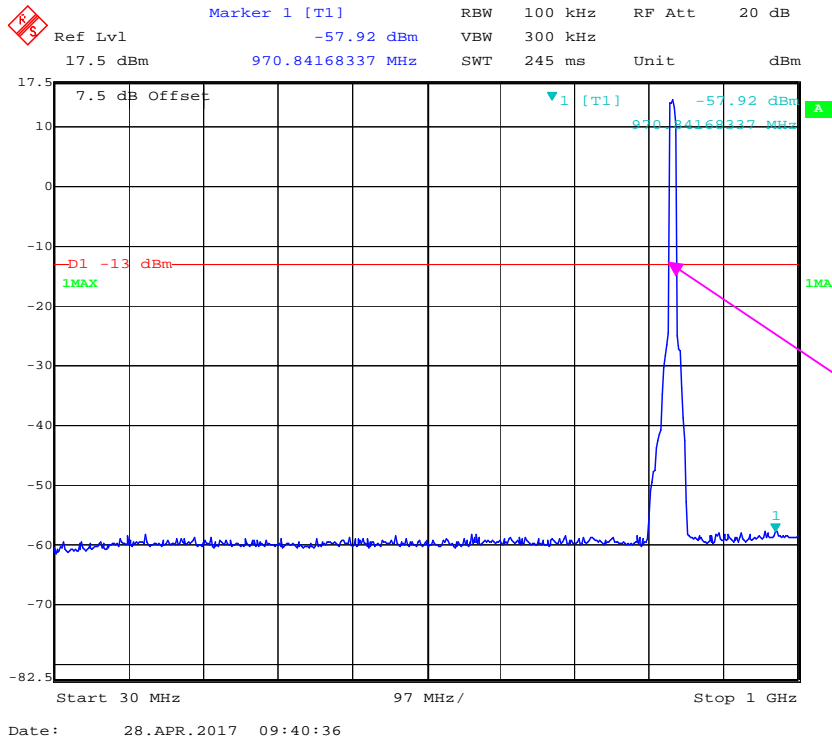

### 1 GHz - 10 GHz (10.0 MHz, Middle Channel)

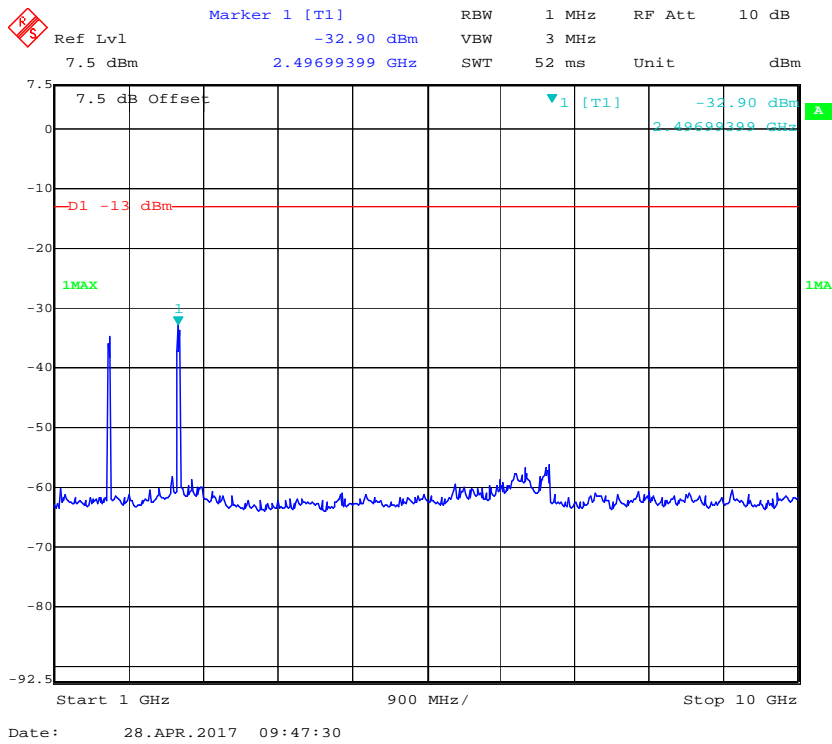

LTE Band 7:

30 MHz – 1 GHz (5.0 MHz, Middle Channel)

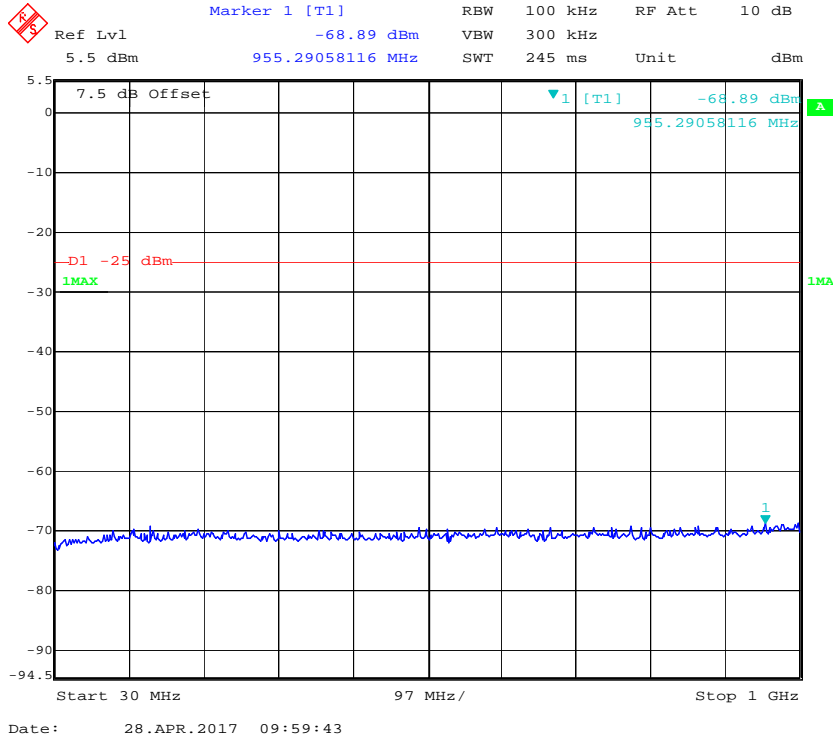

1 GHz – 26 GHz (5.0 MHz, Middle Channel)

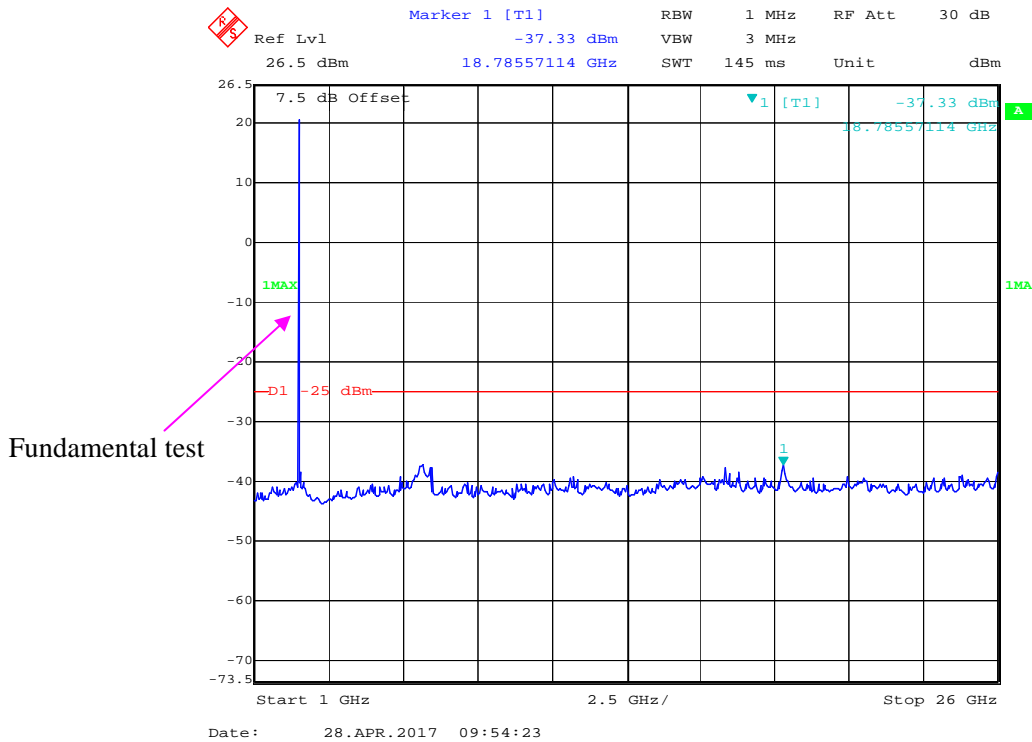

**30 MHz – 1.0 GHz (10.0 MHz, Middle Channel)**

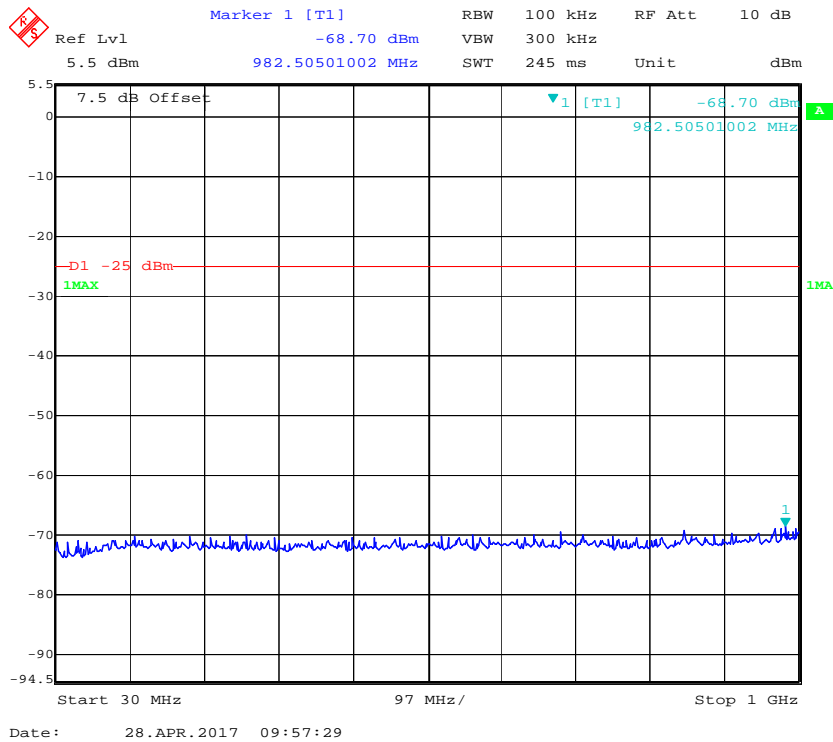

**1 GHz – 26 GHz (10.0 MHz, Middle Channel)**

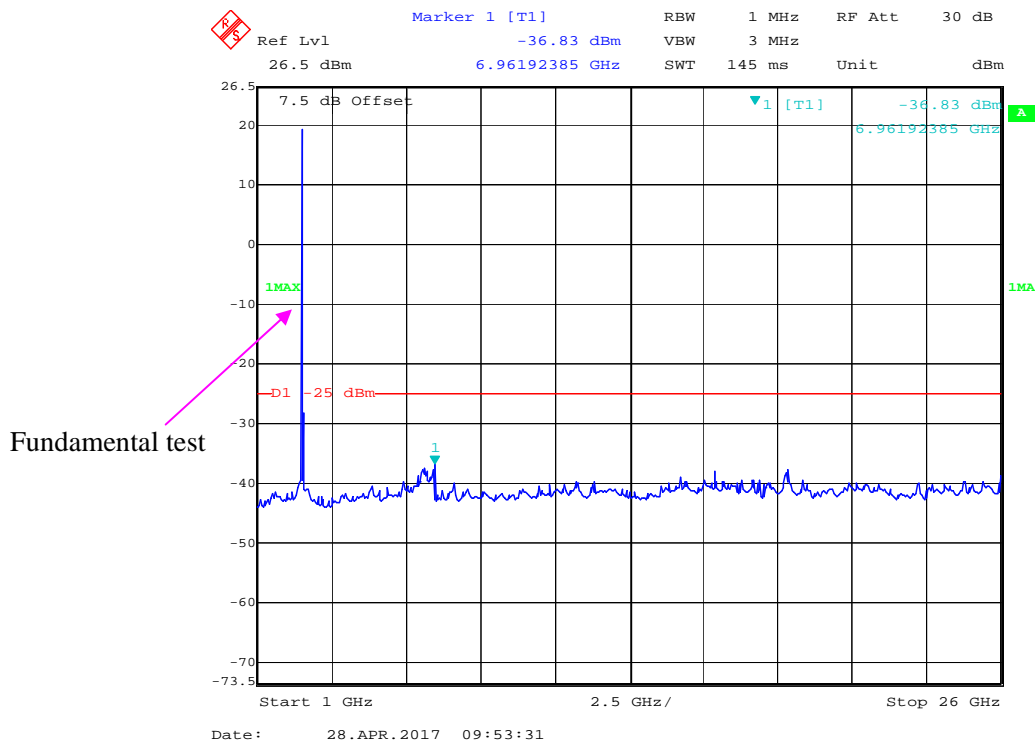

### 30 MHz – 1 GHz (15.0 MHz, Middle Channel)

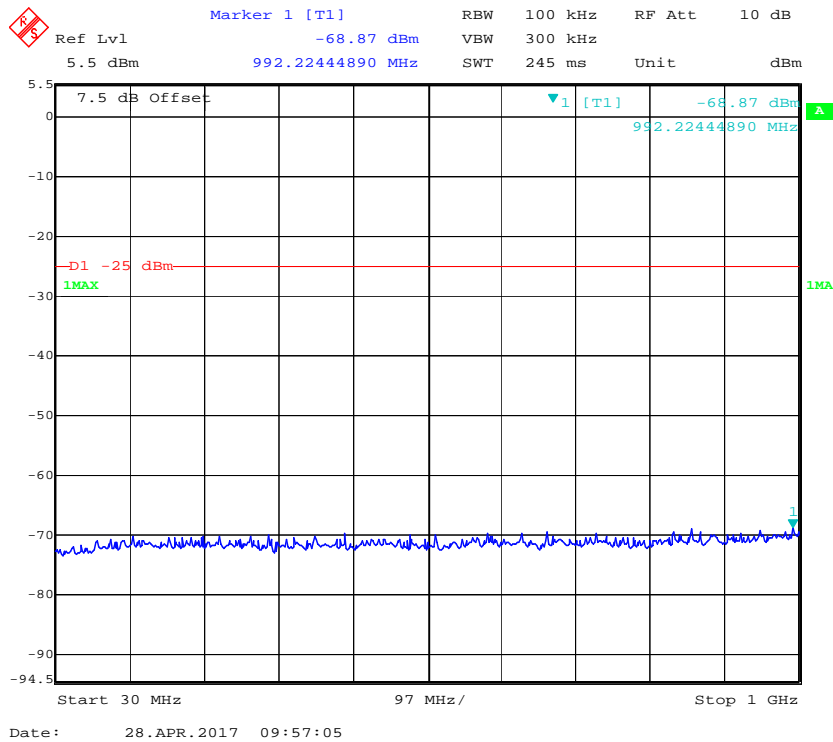

### 1 GHz – 26 GHz (15.0 MHz, Middle Channel)

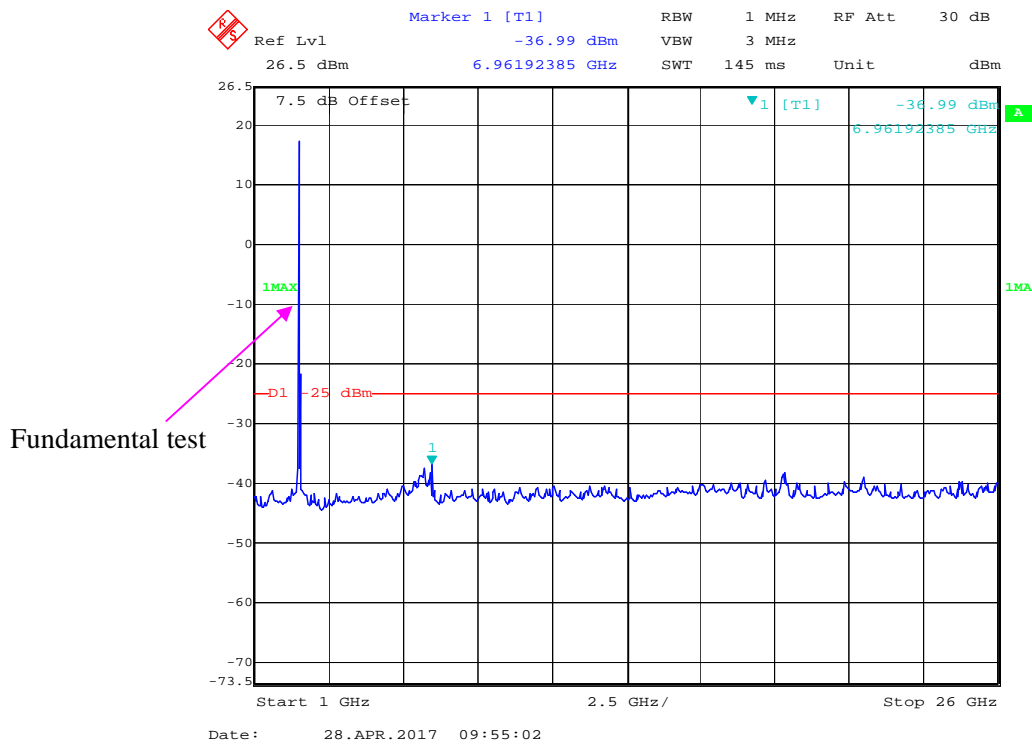



### 30 MHz – 1 GHz (20.0 MHz, Middle Channel)

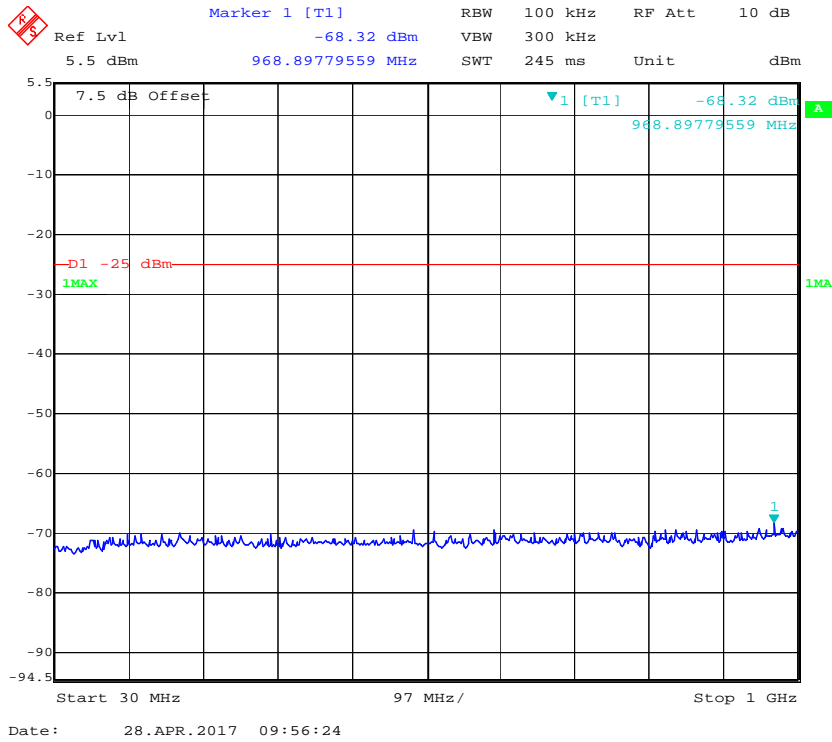

### 1 GHz – 26 GHz (20.0 MHz, Middle Channel)

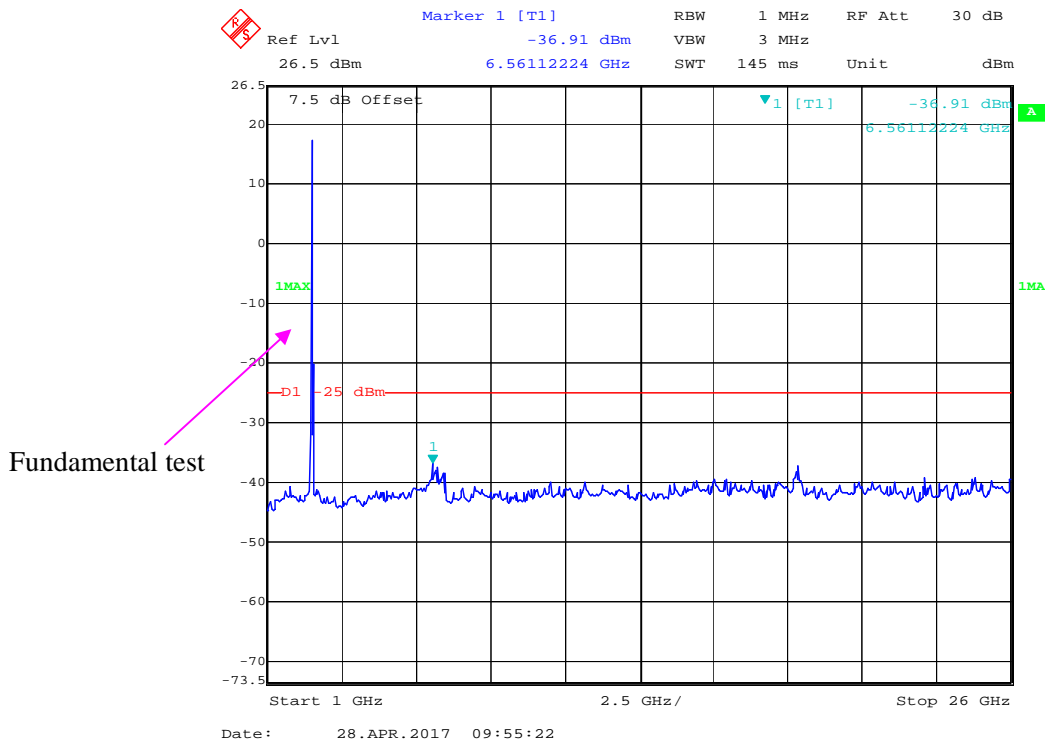

LTE Band 26:

30 MHz - 1 GHz (1.4 MHz, Middle Channel)

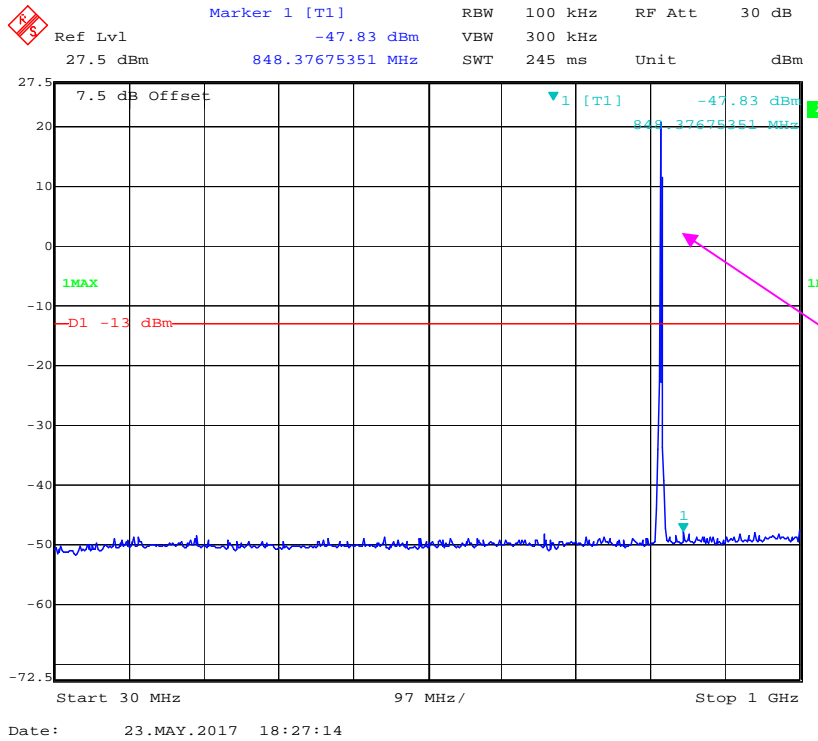

1 GHz - 10 GHz (1.4 MHz, Middle Channel)

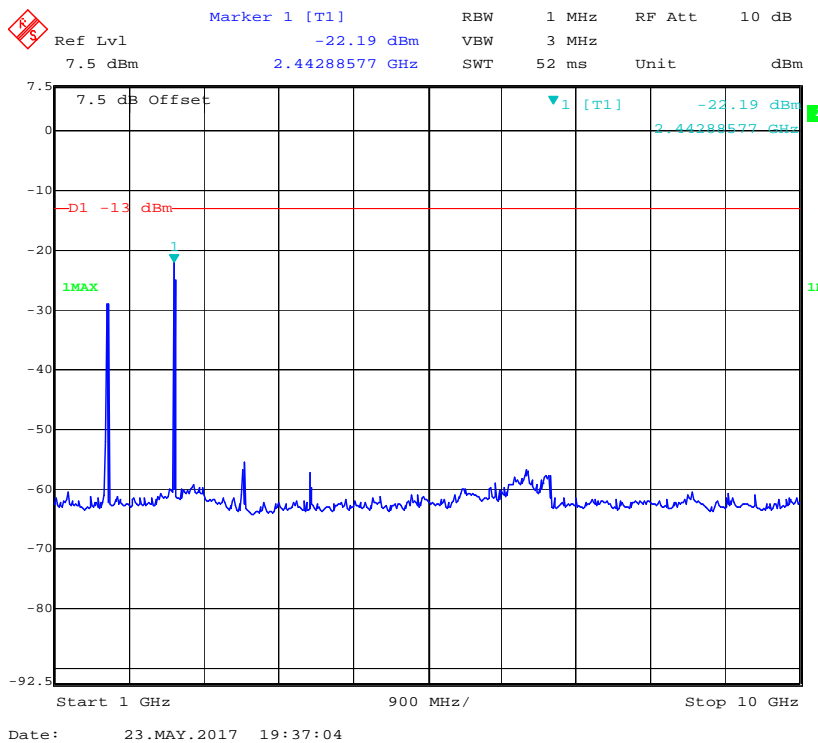

### 30 MHz – 1 GHz (3.0 MHz, Middle Channel)

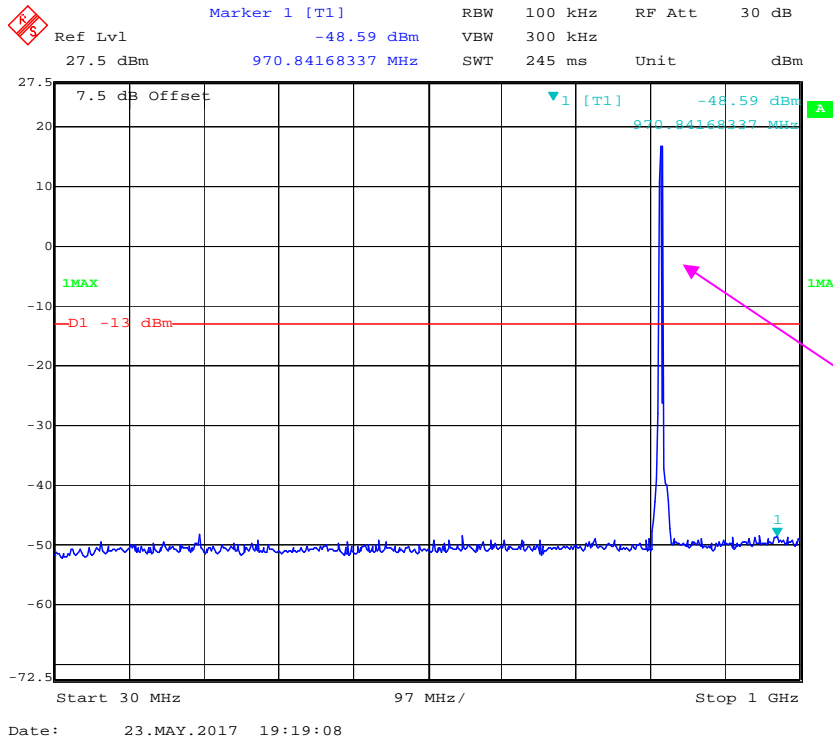

### 1 GHz – 10 GHz (3.0 MHz, Middle Channel)

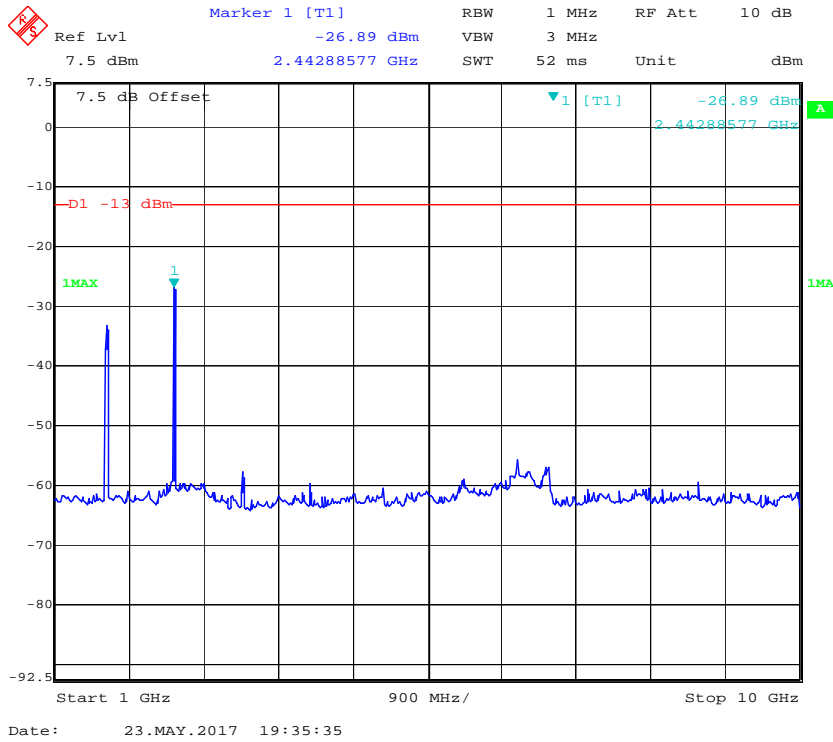

### 30 MHz – 1.0 GHz (5.0 MHz, Middle Channel)

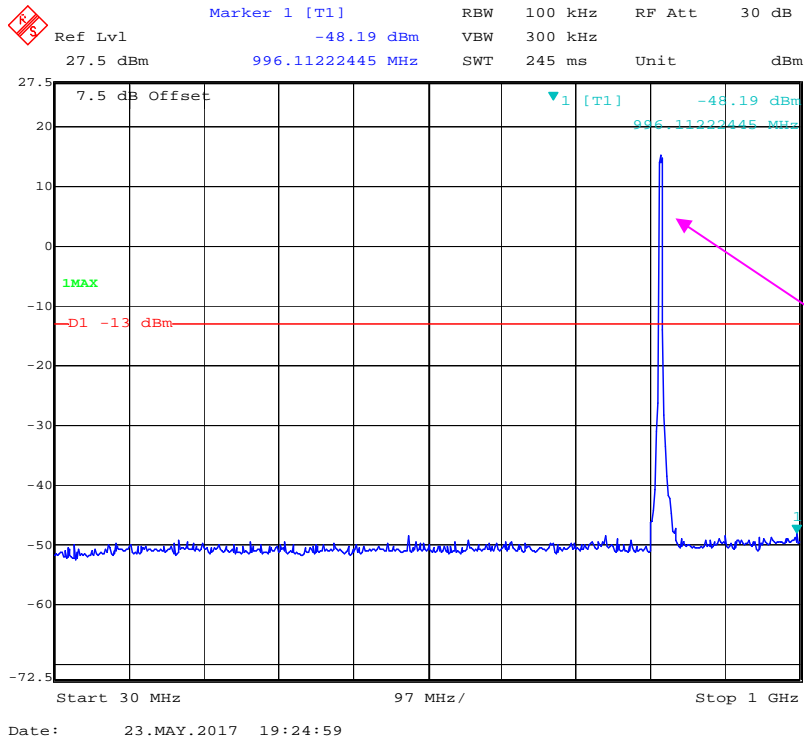

### 1 GHz – 10 GHz (5.0 MHz, Middle Channel)

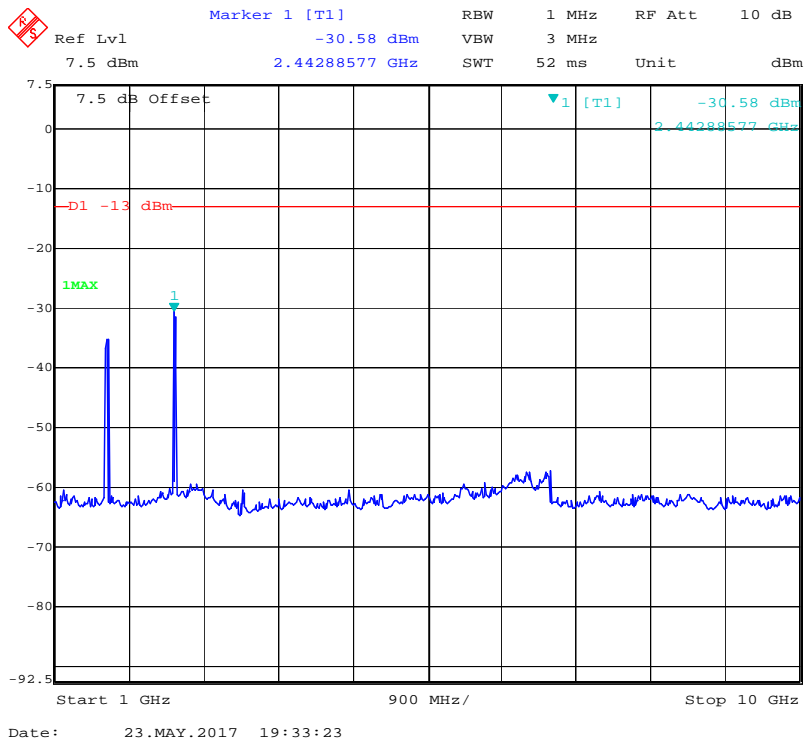



**LTE Band 38:**

**30 MHz – 1 GHz (5.0 MHz, Middle Channel)**

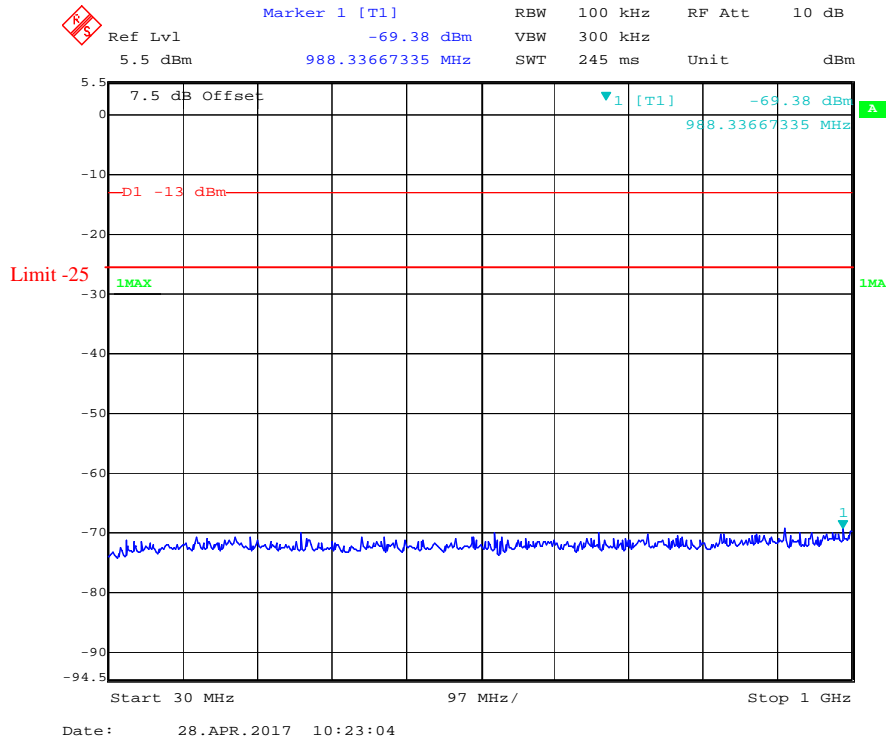

**1 GHz – 26.5GHz (5.0 MHz, Middle Channel)**

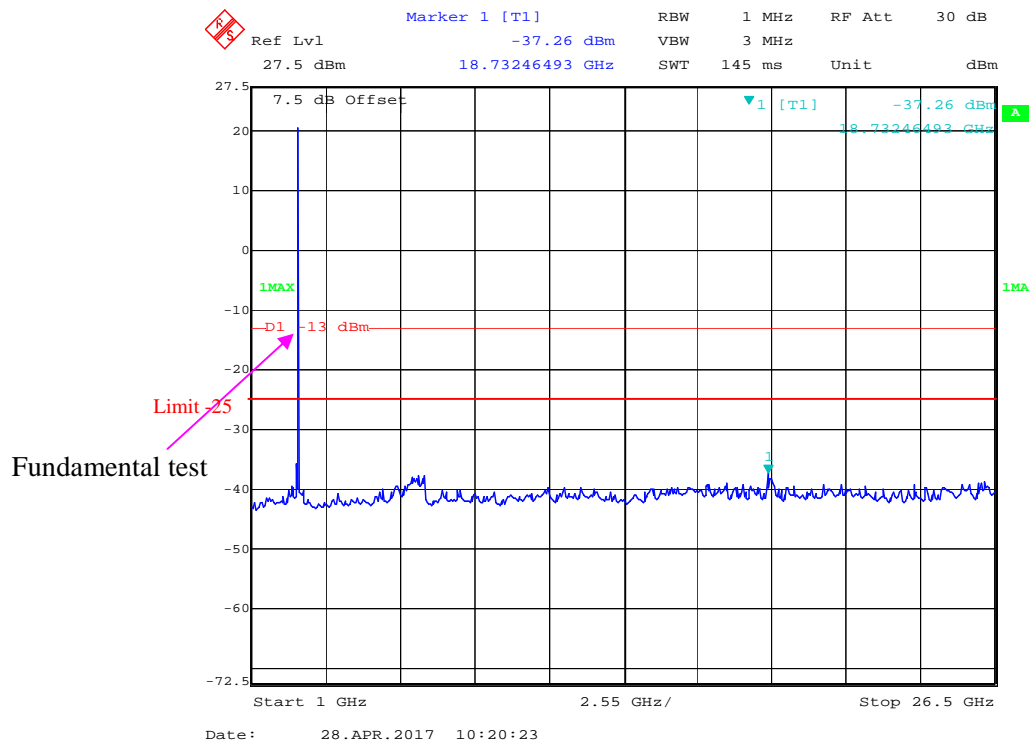

30 MHz – 1.0 GHz (10.0 MHz, Middle Channel)

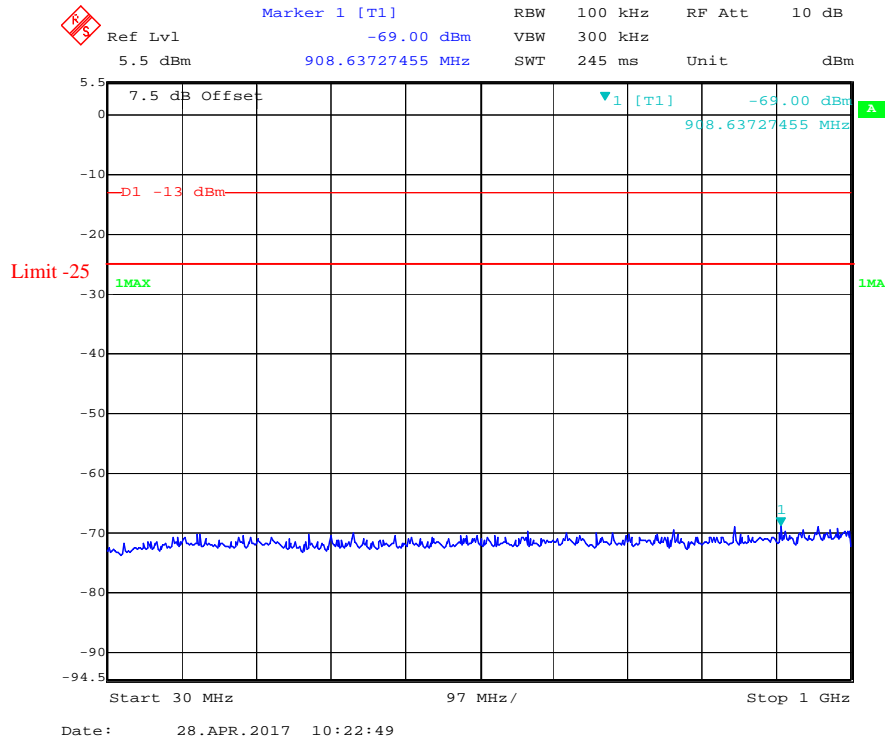

1 GHz – 26.5 GHz (10.0 MHz, Middle Channel)

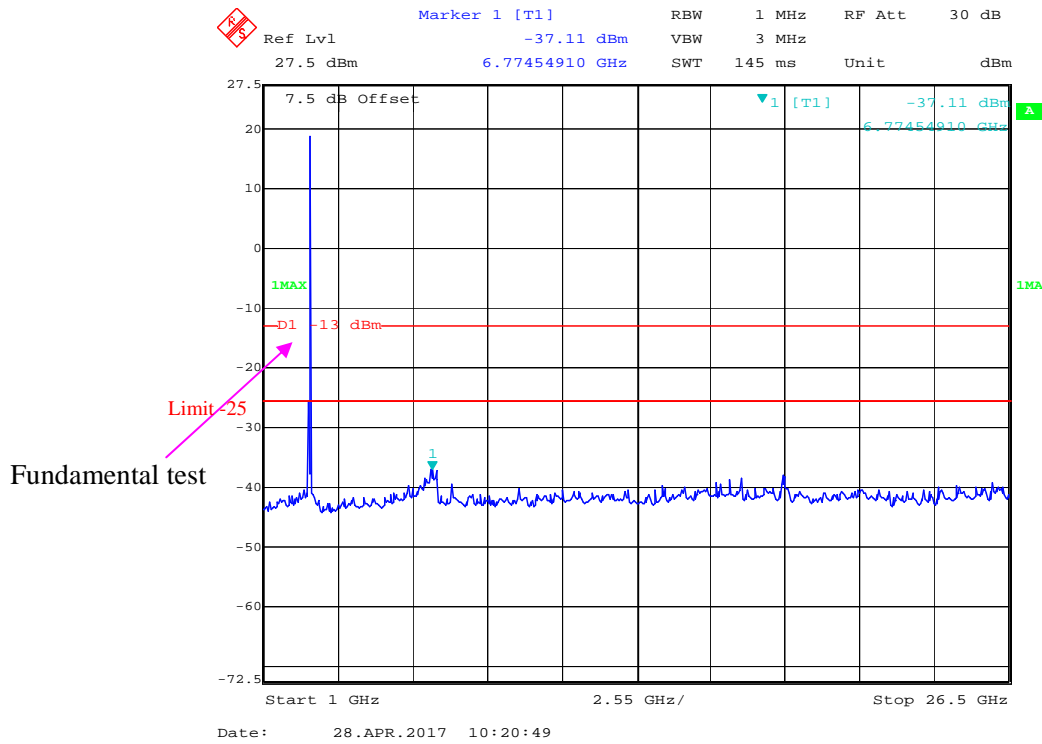

### 30 MHz – 1 GHz (15.0 MHz, Middle Channel)

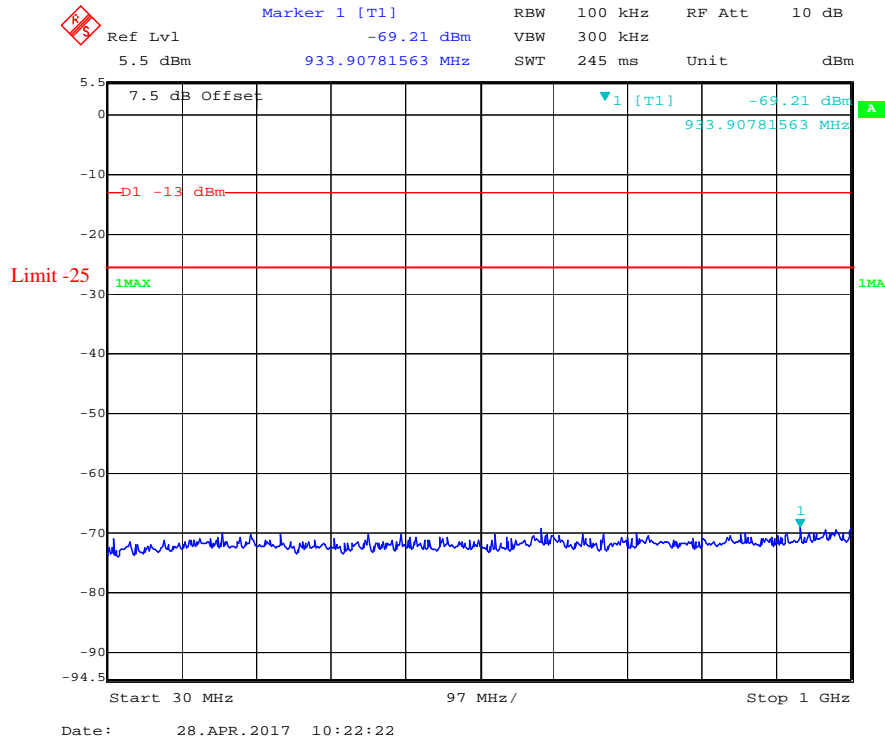

### 1 GHz – 26.5 GHz (15.0 MHz, Middle Channel)

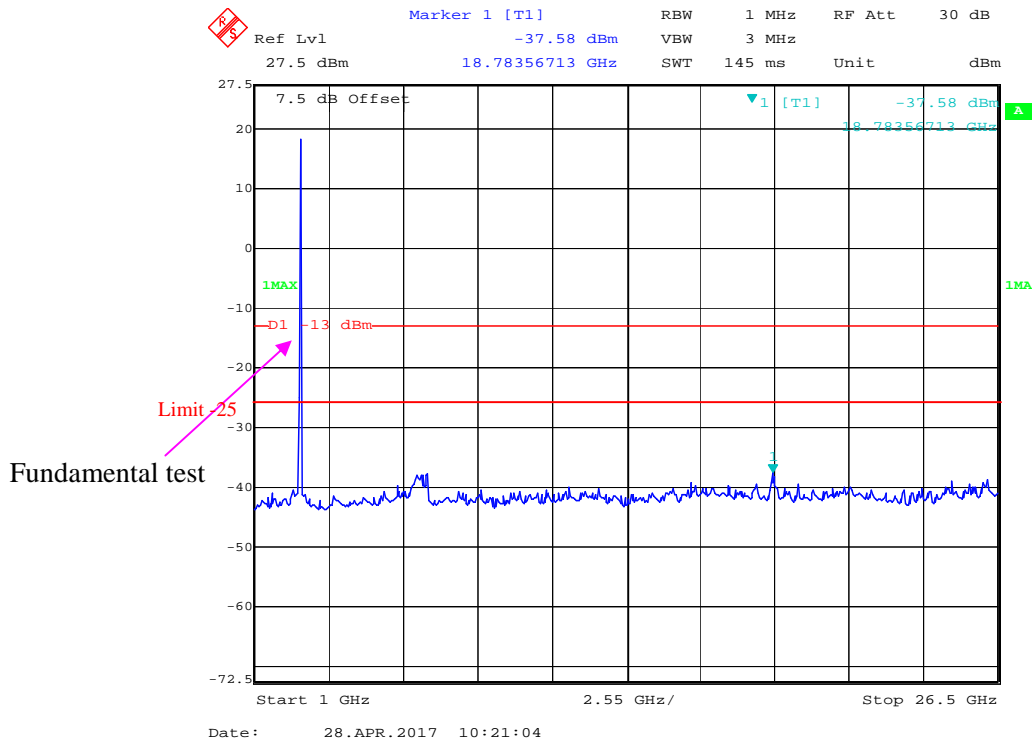



### 30 MHz – 1 GHz (20.0 MHz, Middle Channel)

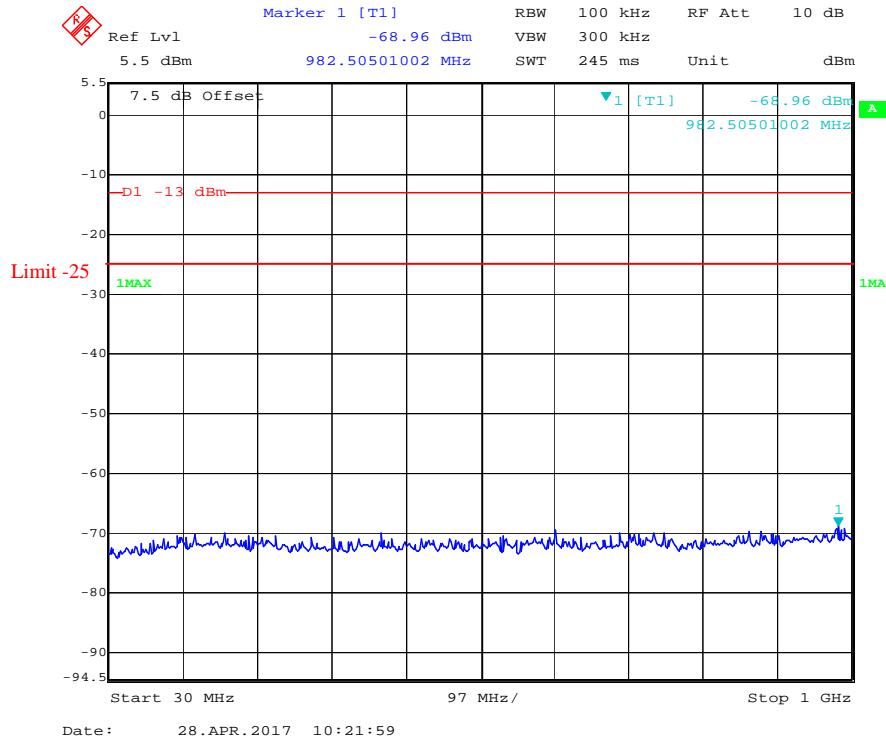

### 1 GHz – 26.5 GHz (20.0 MHz, Middle Channel)

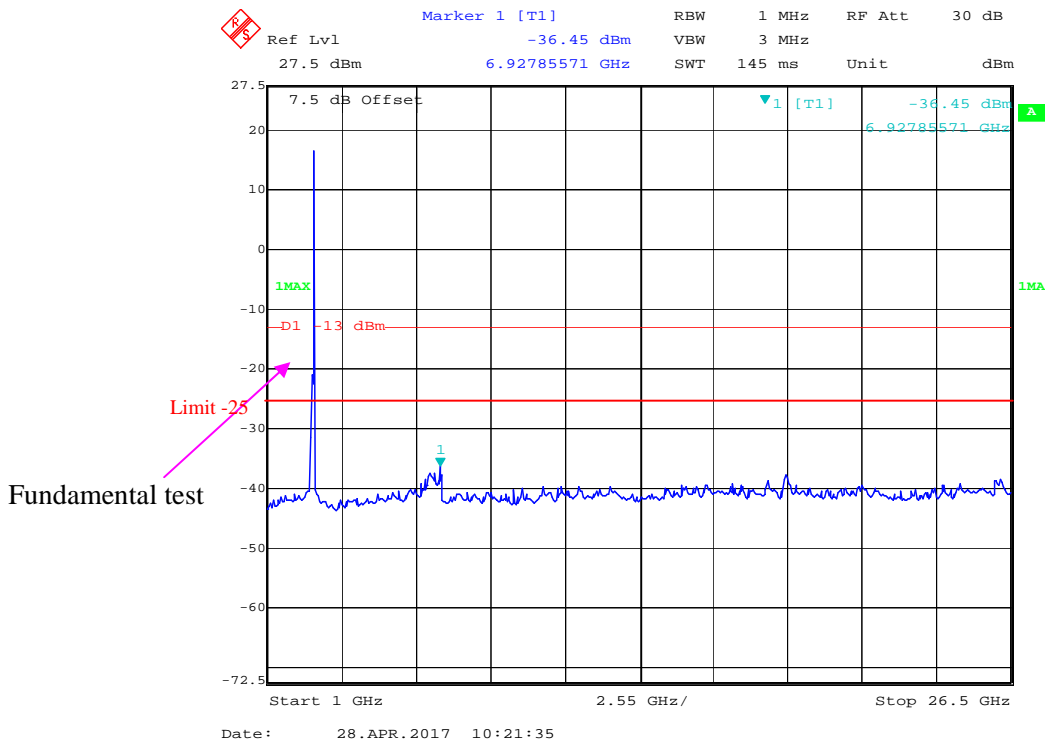

LTE Band 41:

30 MHz – 1 GHz (5.0 MHz, Middle Channel)

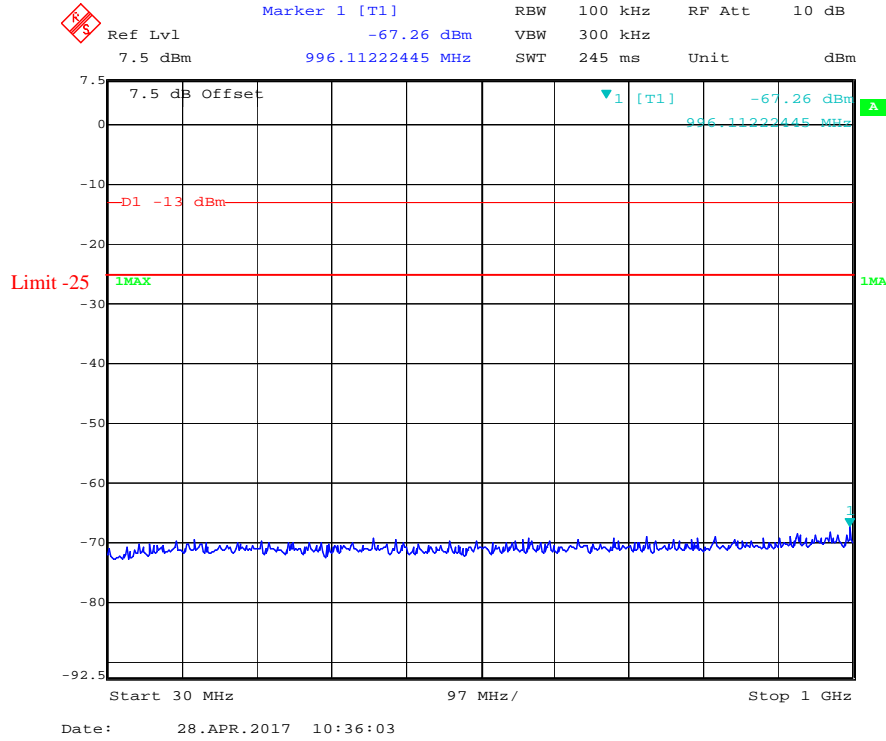

1 GHz – 26.5 GHz (5.0 MHz, Middle Channel)

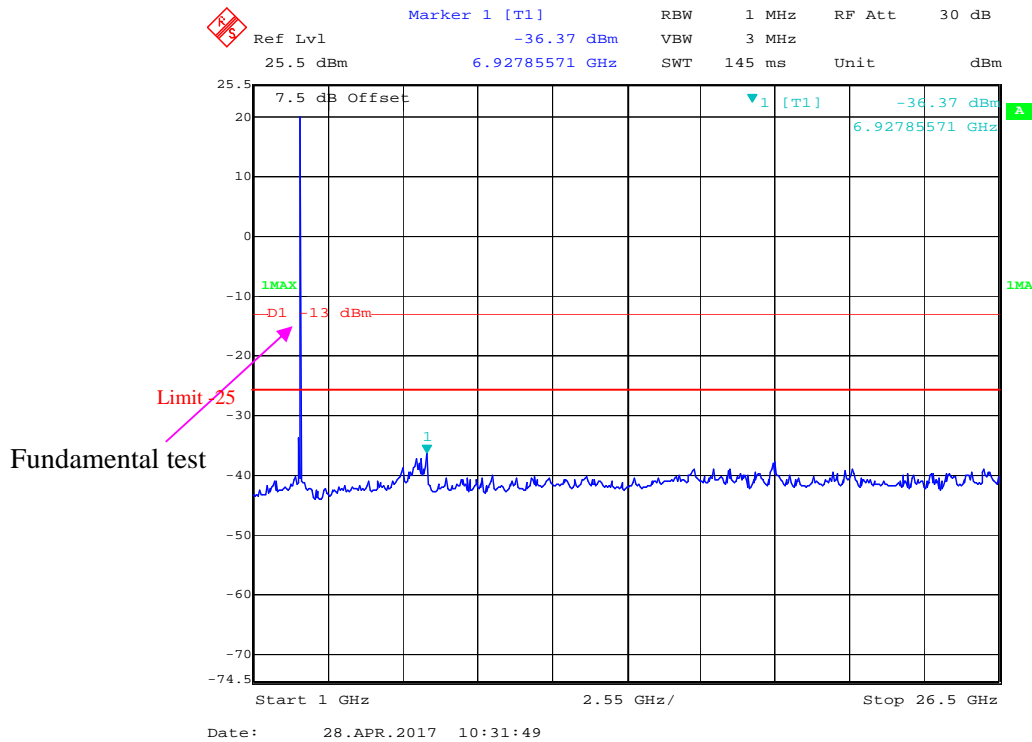

**26.5 GHz – 40 GHz (5.0 MHz, Middle Channel)**

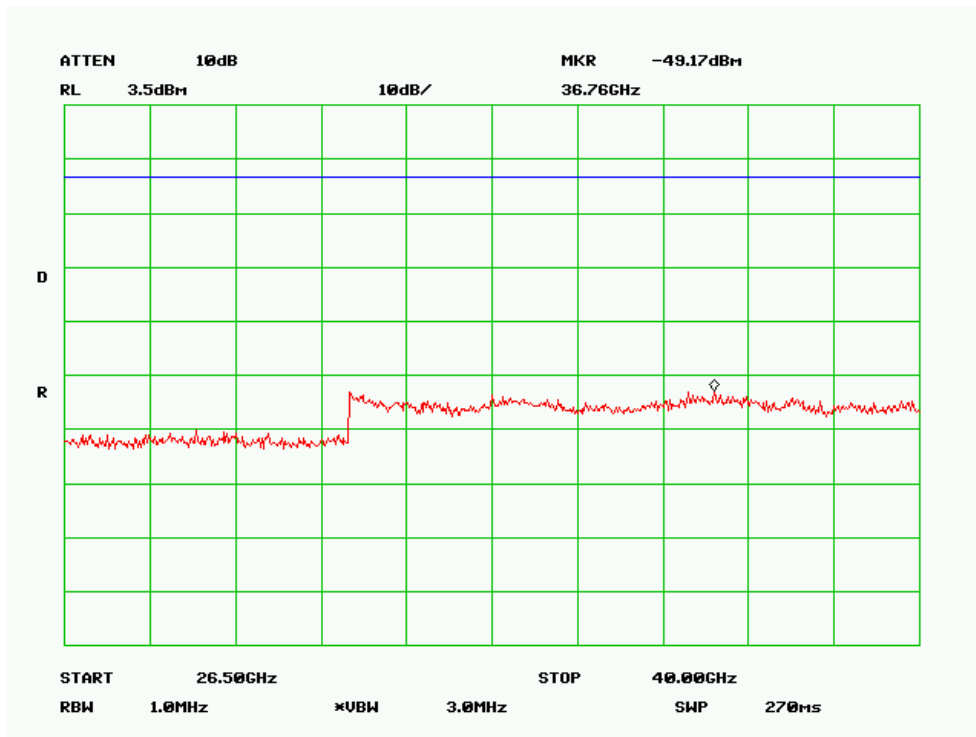

**30 MHz – 1.0 GHz (10.0 MHz, Middle Channel)**

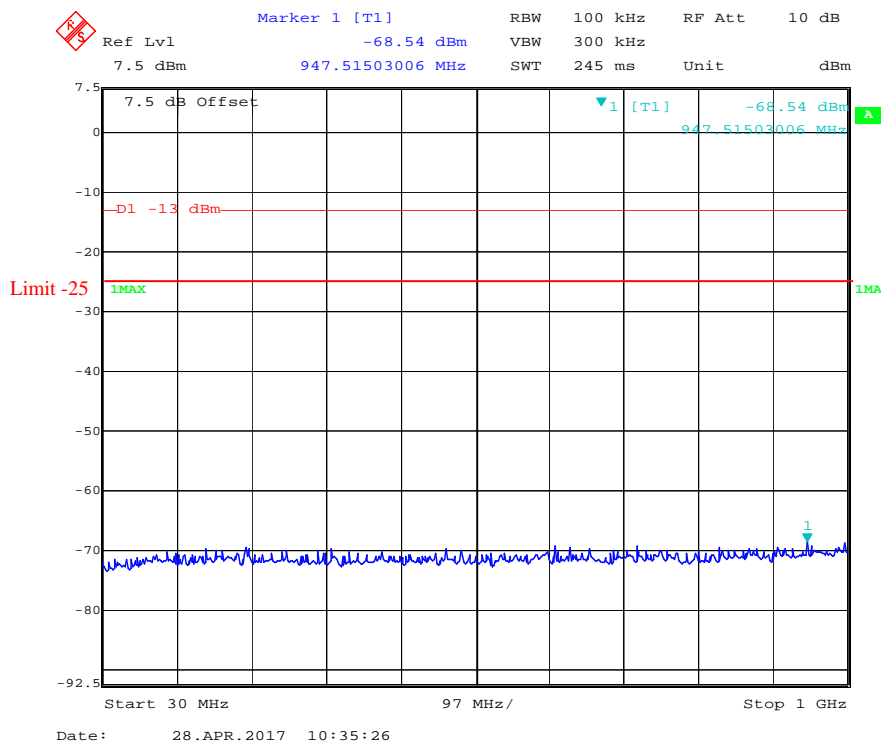

**1 GHz – 26.5 GHz (10.0 MHz, Middle Channel)**

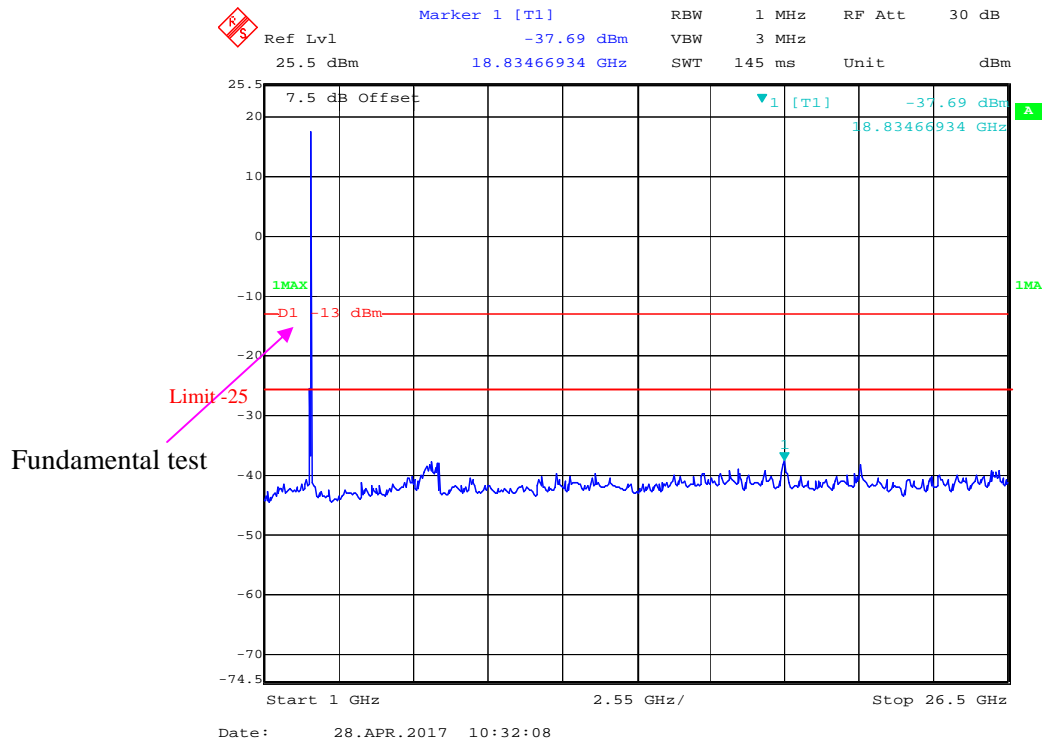

**26.5 GHz – 40 GHz (10.0 MHz, Middle Channel)**

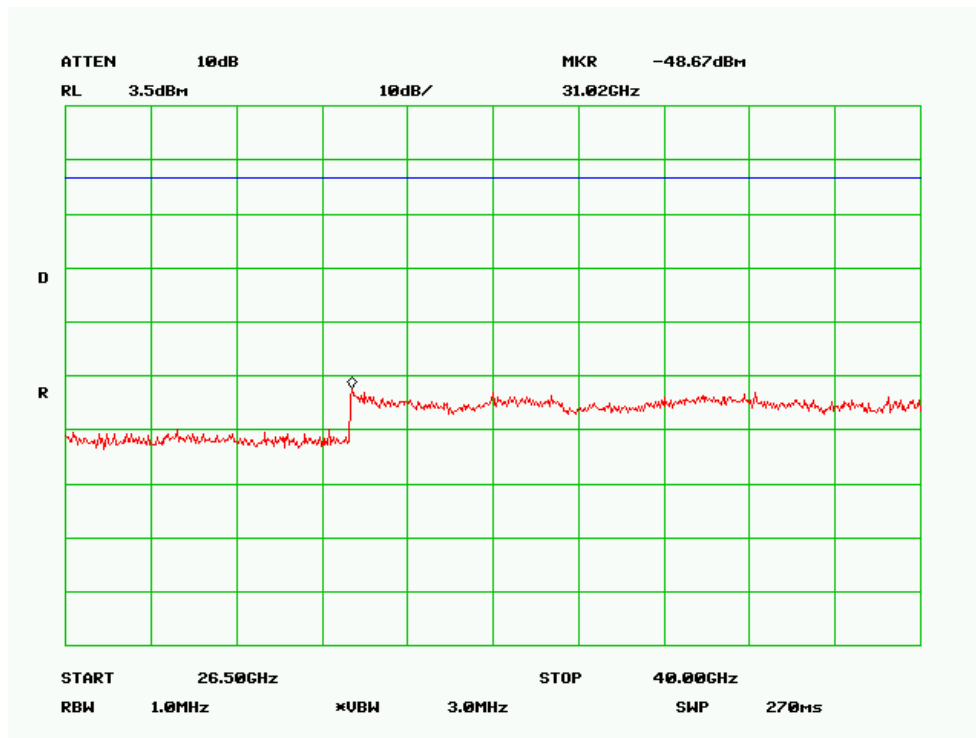



**26.5 GHz – 40 GHz (15.0 MHz, Middle Channel)**

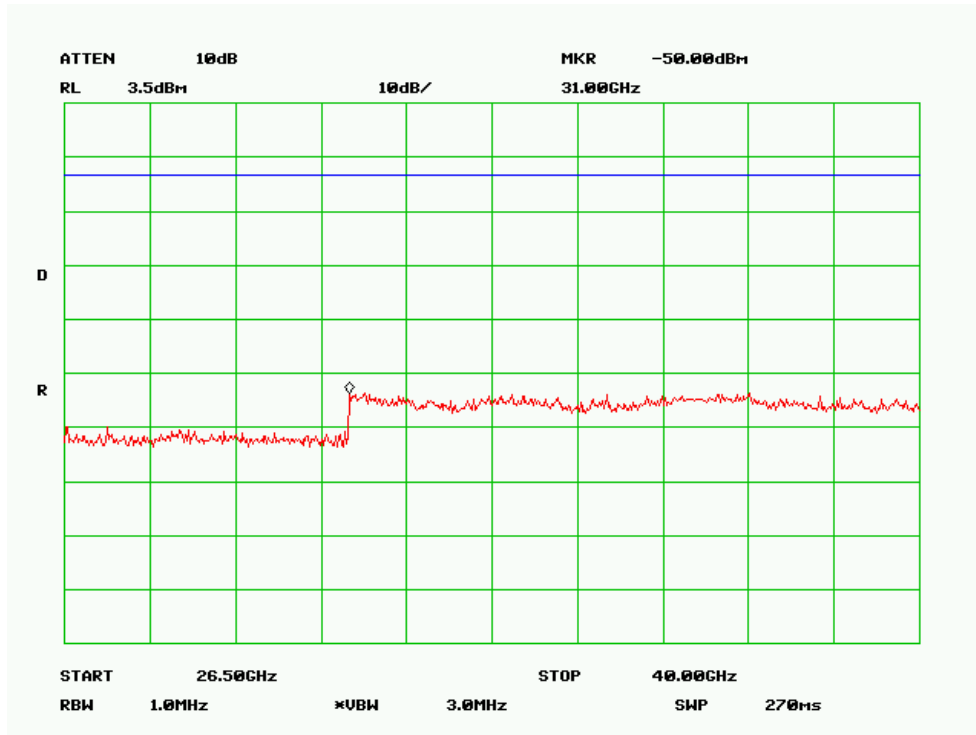

**30 MHz – 1 GHz (20.0 MHz, Middle Channel)**

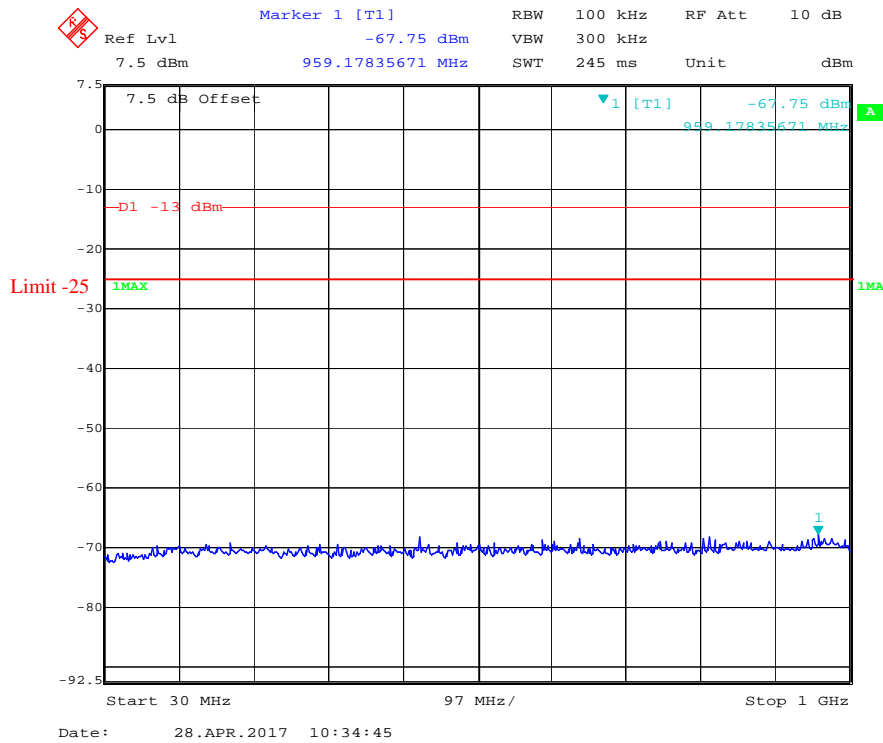

**1 GHz – 26.5 GHz (20.0 MHz, Middle Channel)**

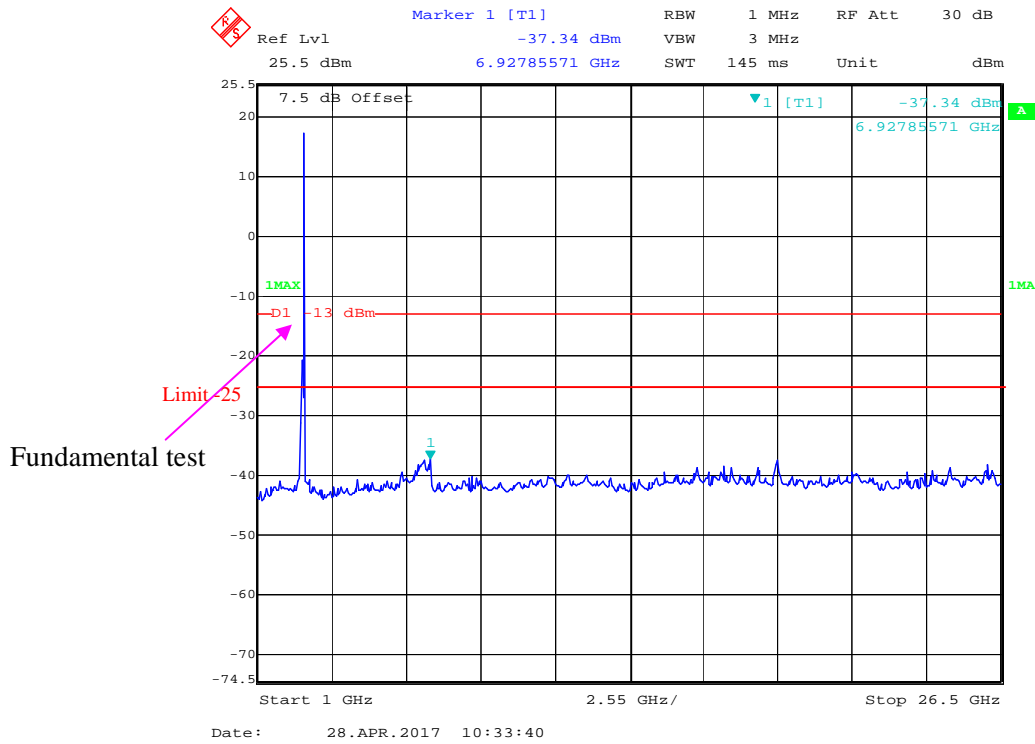

**26.5 GHz – 40 GHz (20.0 MHz, Middle Channel)**

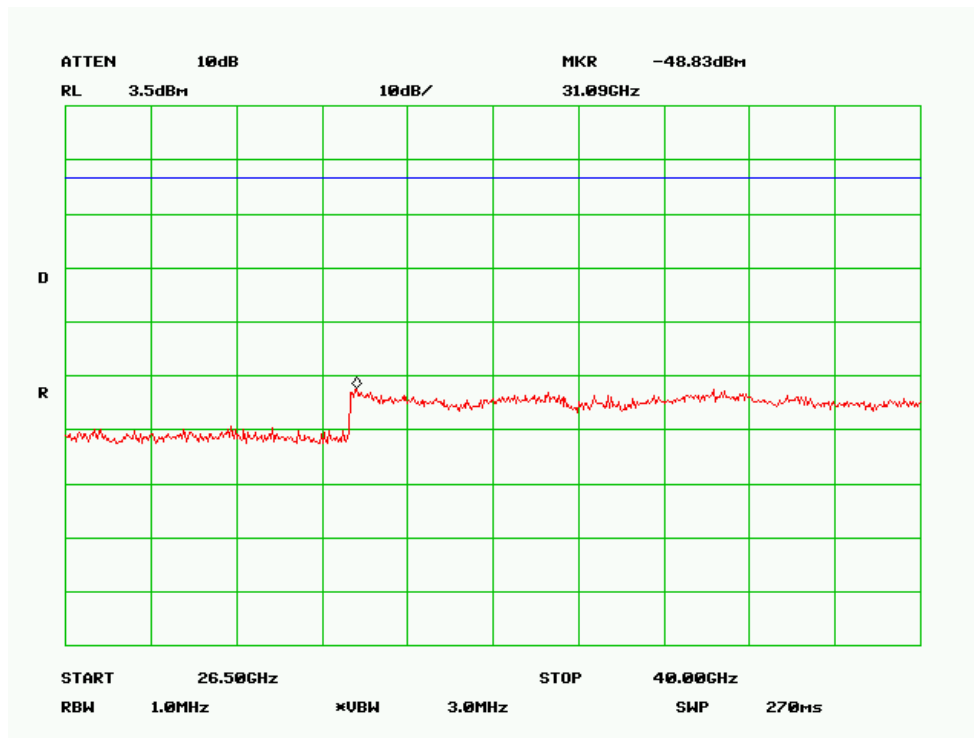

## **FCC § 2.1053; § 22.917 (a); § 24.238 (a); § 27.53(a)(h)(m) ; § 90.691 SPURIOUS RADIATED EMISSIONS**

### **Applicable Standard**

FCC § 2.1053, § 22.917(a) and § 24.238(a) and § 27.53(a)(h)(m) and § 90.691.

For mobile digital stations, the attenuation factor shall be not less than  $40 + 10 \log (P)$  dB on all frequencies between the channel edge and 5 megahertz from the channel edge,  $43 + 10 \log (P)$  dB on all frequencies between 5 megahertz and X megahertz from the channel edge, and  $55 + 10 \log (P)$  dB on all frequencies more than X megahertz from the channel edge, where X is the greater of 6 megahertz or the actual emission bandwidth as defined in paragraph (m)(6) of this section. In addition, the attenuation factor shall not be less than  $43 + 10 \log (P)$  dB on all frequencies between 2490.5 MHz and 2496 MHz and  $55 + 10 \log (P)$  dB at or below 2490.5 MHz. Mobile Satellite Service licensees operating on frequencies below 2495 MHz may also submit a documented interference complaint against BRS licensees operating on channel BRS Channel 1 on the same terms and conditions as adjacent channel BRS or EBS licensees.

### **Test Procedure**

The transmitter was placed on a wooden turntable, and it was transmitting into a non-radiating load which was also placed on the turntable.

The measurement antenna was placed at a distance of 3 meters from the EUT. During the tests, the receiving antenna height and polarization as well as EUT azimuth were varied in order to identify the maximum level of emissions from the EUT. The test was performed by placing the EUT on 3-orthogonal axis.

The frequency range up to tenth harmonic of the fundamental frequency was investigated.

Remove the EUT and replace it with substitution antenna. A signal generator was connected to the substitution antenna by a non-radiating cable. The absolute levels of the spurious emissions were measured by the substitution.

Spurious emissions in dB =  $10 \lg (\text{TX pwr in Watts}/0.001)$  – the absolute level

Spurious attenuation limit in dB =  $43 + 10 \text{Log}_{10} (\text{power out in Watts})$

Spurious attenuation limit in dB =  $55 + 10 \text{Log}_{10} (\text{power out in Watts})$

### **Test Data**

#### **Environmental Conditions**

<b>Temperature:</b>	24 °C
<b>Relative Humidity:</b>	54 %
<b>ATM Pressure:</b>	101.0 kPa

*The testing was performed by Layne Li on 2017-05-02*

*EUT operation mode: Transmitting*



Pre-scan with Low, Middle and High channel, the worst case as below:

30 MHz ~ 10 GHz:

**Cellular Band (Part 22H)**

Frequency (MHz)	Receiver Reading (dBµV)	Turntable Angle Degree	Rx Antenna		Substituted			Absolute Level (dBm)	Limit (dBm)	Margin (dB)
			Height (m)	Polar (H/V)	Level (dBm)	Cable Loss (dB)	Antenna Gain (dB)			
<b>GSM Mode, Middle channel</b>										
350.9	43.55	78	1.1	H	-59.1	0.23	4.65	-54.68	-13	41.68
350.9	46.49	123	1.2	V	-59.3	0.23	4.65	-54.88	-13	41.88
1673.20	57.12	90	1.9	H	-44.7	0.40	8.52	-36.58	-13	23.58
1673.20	63.19	202	1.1	V	-40.6	0.40	8.52	-32.48	-13	19.48
<b>CDMA, Middle channel</b>										
350.9	42.95	78	1.4	H	-59.7	0.23	4.65	-55.28	-13	42.28
350.9	46.39	123	1.2	V	-59.4	0.23	4.65	-54.98	-13	41.98
1673.04	56.52	343	1.6	H	-45.3	0.40	8.52	-37.18	-13	24.18
1673.04	60.19	123	2.0	V	-43.6	0.40	8.52	-35.48	-13	22.48
<b>CDMA(EV-DO), Middle channel</b>										
350.9	43.45	136	1.5	H	-59.2	0.23	4.65	-54.78	-13	41.78
350.9	46.49	142	1.2	V	-59.3	0.23	4.65	-54.88	-13	41.88
1673.04	54.42	181	2.3	H	-47.4	0.40	8.52	-39.28	-13	26.28
1673.04	56.89	270	2.0	V	-46.9	0.40	8.52	-38.78	-13	25.78

30 MHz ~ 20 GHz:

**PCS Band (Part 24E)**

Frequency (MHz)	Receiver Reading (dBµV)	Turntable Angle Degree	Rx Antenna		Substituted			Absolute Level (dBm)	Limit (dBm)	Margin (dB)
			Height (m)	Polar (H/V)	Level (dBm)	Cable Loss (dB)	Antenna Gain (dB)			
<b>GSM Mode, Middle channel</b>										
350.9	43.85	78	1.1	H	-58.8	0.23	4.65	-54.38	-13	41.38
350.9	46.59	123	1.2	V	-59.2	0.23	4.65	-54.78	-13	41.78
3760.00	41.15	171	1.8	H	-54.9	0.59	9.72	-45.77	-13	32.77
3760.00	44.34	144	2.1	V	-52.8	0.59	9.72	-43.67	-13	30.67

**LTE Band:**

*Test mode: Transmitting (Pre-scan with all the bandwidth, and worse case as below)*

Frequency (MHz)	Receiver Reading (dBμV)	Turntable Angle Degree	Rx Antenna		Substituted			Absolute Level (dBm)	Limit (dBm)	Margin (dB)
			Height (m)	Polar (H/V)	Level (dBm)	Cable Loss (dB)	Antenna Gain (dB)			
<b>Band 2</b>										
<b>Test frequency range:30 MHz ~ 20 GHz</b>										
347.62	52.22	42	1.3	H	-57.5	0.2	3.85	-53.85	-13	40.85
347.62	49.23	55	1.7	V	-57.9	0.2	3.85	-54.25	-13	41.25
3760.00	46.15	337	1.1	H	-49.9	0.59	9.72	-40.77	-13	27.77
3760.00	47.64	263	1.4	V	-49.5	0.59	9.72	-40.37	-13	27.37
<b>Band 4</b>										
<b>Test frequency range:30 MHz ~ 20 GHz</b>										
347.62	52.42	54	1.2	H	-57.3	0.2	3.85	-53.65	-13	40.65
347.62	49.53	39	1.0	V	-57.6	0.2	3.85	-53.95	-13	40.95
3465.00	42.19	207	1.1	H	-54.8	0.54	9.90	-45.44	-13	32.44
3465.00	45.69	268	1.4	V	-52.6	0.54	9.90	-43.24	-13	30.24
<b>Band 5</b>										
<b>Test frequency range:30 MHz ~ 10 GHz</b>										
347.62	51.62	98	1.3	H	-58.1	0.2	3.85	-54.45	-13	41.45
347.62	49.33	105	1.2	V	-57.8	0.2	3.85	-54.15	-13	41.15
1673.00	44.52	186	1.9	H	-57.3	0.40	8.52	-49.18	-13	36.18
1673.00	50.89	299	2.1	V	-52.9	0.40	8.52	-44.78	-13	31.78
<b>Band 7</b>										
<b>Test frequency range: 30 MHz ~ 26 GHz</b>										
347.62	51.52	47	1.3	H	-58.2	0.2	3.85	-54.55	-25	29.55
347.62	49.13	220	1.5	V	-58.0	0.2	3.85	-54.35	-25	29.35
5070.00	45.80	68	1.5	H	-47.3	0.64	10.30	-37.64	-25	12.64
5070.00	49.83	87	1.2	V	-44.8	0.64	10.30	-35.14	-25	10.14
<b>Band 26</b>										
<b>Test frequency range: 30 MHz ~ 10 GHz</b>										
347.62	51.42	94	1.2	H	-58.3	0.2	3.85	-54.65	-13	41.65
347.62	49.03	101	1.3	V	-58.1	0.2	3.85	-54.45	-13	41.45
1638.00	43.98	342	2.3	H	-58.8	0.37	8.36	-50.81	-13	37.81
1638.00	48.02	203	1.0	V	-56.6	0.37	8.36	-48.61	-13	35.61
<b>Band 38</b>										
<b>Test frequency range: 30 MHz ~ 26.5 GHz</b>										
347.62	50.92	85	1.7	H	-58.8	0.2	3.85	-55.15	-25	30.15
347.62	48.83	140	1.3	V	-58.3	0.2	3.85	-54.65	-25	29.65
5190.00	45.40	104	2.2	H	-47.7	0.64	10.30	-38.04	-25	13.04
5190.00	52.73	265	2.2	V	-41.9	0.64	10.30	-32.24	-25	7.24

Frequency (MHz)	Receiver Reading (dBµV)	Turntable Angle Degree	Rx Antenna		Substituted			Absolute Level (dBm)	Limit (dBm)	Margin (dB)
			Height (m)	Polar (H/V)	Level (dBm)	Cable Loss (dB)	Antenna Gain (dB)			
<b>Band 41</b>										
<b>Test frequency range:30 MHz ~ 40 GHz</b>										
347.62	53.02	120	1.6	H	-56.7	0.2	3.85	-53.05	-25	28.05
347.62	48.23	28	1.5	V	-58.9	0.2	3.85	-55.25	-25	30.25
5186.00	43.60	34	1.4	H	-49.5	0.64	10.30	-39.84	-25	14.84
5186.00	48.33	189	2.2	V	-46.3	0.64	10.30	-36.64	-25	11.64

**Note:**

- 1) Absolute Level = Substituted Level - Cable loss + Antenna Gain
- 2) Margin = Limit- Absolute Level

## **FCC § 22.917 (a); § 24.238 (a); §27.53 (a)(h)(m) §90.691 - BAND EDGES**

### **Applicable Standard**

According to § 22.917(a), the power of any emissions outside of the authorized operating frequency ranges must be attenuated below the transmitting power (P) by a factor of at least  $43 + 10 \log(P)$  dB.

According to §24.238(a), the power of any emissions outside of the authorized operating frequency ranges must be attenuated below the transmitting power (P) by a factor of at least  $43 + 10 \log(P)$  dB.

According to FCC §27.53 (a)(h)(m), the power of any emission outside of the authorized operating frequency ranges must be attenuated below the transmitting power (P) by a factor of at least  $43 + 10 \log(P)$  dB.

For mobile digital stations, the attenuation factor shall be not less than  $40 + 10 \log (P)$  dB on all frequencies between the channel edge and 5 megahertz from the channel edge,  $43 + 10 \log (P)$  dB on all frequencies between 5 megahertz and X megahertz from the channel edge, and  $55 + 10 \log (P)$  dB on all frequencies more than X megahertz from the channel edge, where X is the greater of 6 megahertz or the actual emission bandwidth as defined in paragraph (m)(6) of this section. In addition, the attenuation factor shall not be less that  $43 + 10 \log (P)$  dB on all frequencies between 2490.5 MHz and 2496 MHz and  $55 + 10 \log (P)$  dB at or below 2490.5 MHz. Mobile Satellite Service licensees operating on frequencies below 2495 MHz may also submit a documented interference complaint against BRS licensees operating on channel BRS Channel 1 on the same terms and conditions as adjacent channel BRS or EBS licensees.

According to FCC §90.691,:

1) For any frequency removed from the EA licensee's frequency block by up to and including 37.5 kHz, the power of any emission shall be attenuated below the transmitter power (P) in watts by at least  $116 \text{Log}_{10}(f/6.1)$  decibels or  $50 + 10 \text{Log}_{10}(P)$  decibels or 80 decibels, whichever is the lesser attenuation, where f is the frequency removed from the center of the outer channel in the block in kilohertz and where f is greater than 12.5 kHz.

2) For any frequency removed from the EA licensee's frequency block greater than 37.5 kHz, the power of any emission shall be attenuated below the transmitter power (P) in watts by at least  $43 + 10\text{Log}_{10}(P)$  decibels or 80 decibels, whichever is the lesser attenuation, where f is the frequency removed from the center of the outer channel in the block in kilohertz and where f is greater than 37.5 kHz

### **Test Procedure**

The RF output of the transmitter was connected to the input of the spectrum analyzer through sufficient attenuation.

The center of the spectrum analyzer was set to block edge frequency

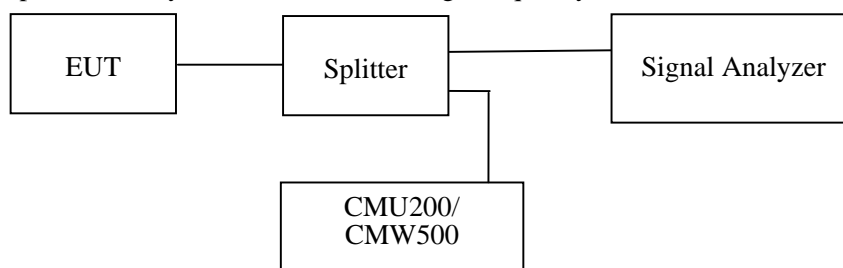

**Test Data**

**Environmental Conditions**

<b>Temperature:</b>	23~25 °C
<b>Relative Humidity:</b>	48~54 %
<b>ATM Pressure:</b>	100.0~101.0 kPa

*The testing was performed by Nefertari Xu from 2017-03-16 to 2017-05-24.*

*EUT operation mode: Transmitting*

*Test Result: Compliance. Please refer to the following plots.*

**Cellular Band, Left Band Edge for GSM (GMSK) Mode**

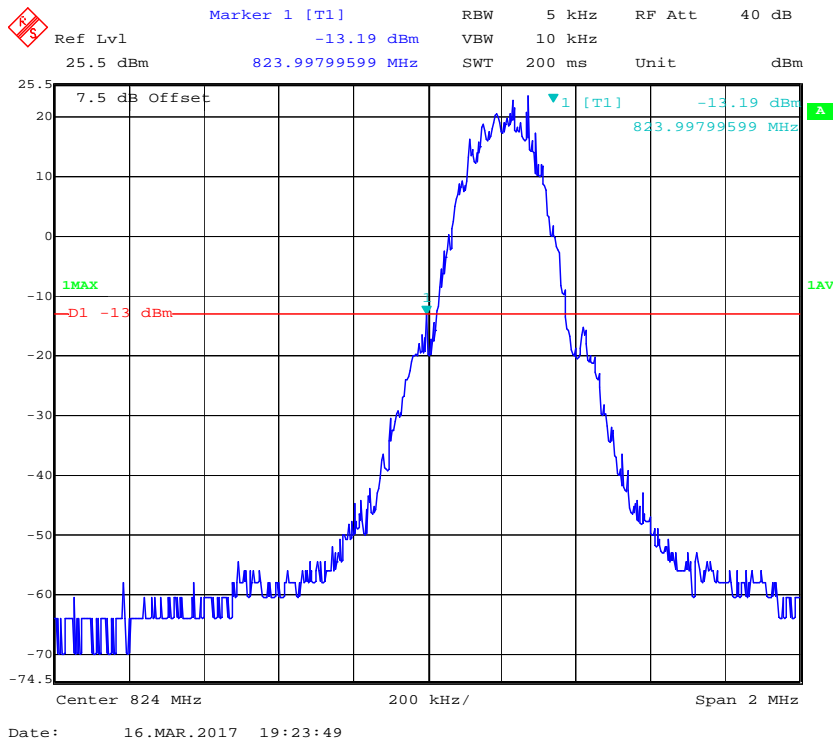

**Cellular Band, Right Band Edge for GSM (GMSK) Mode**

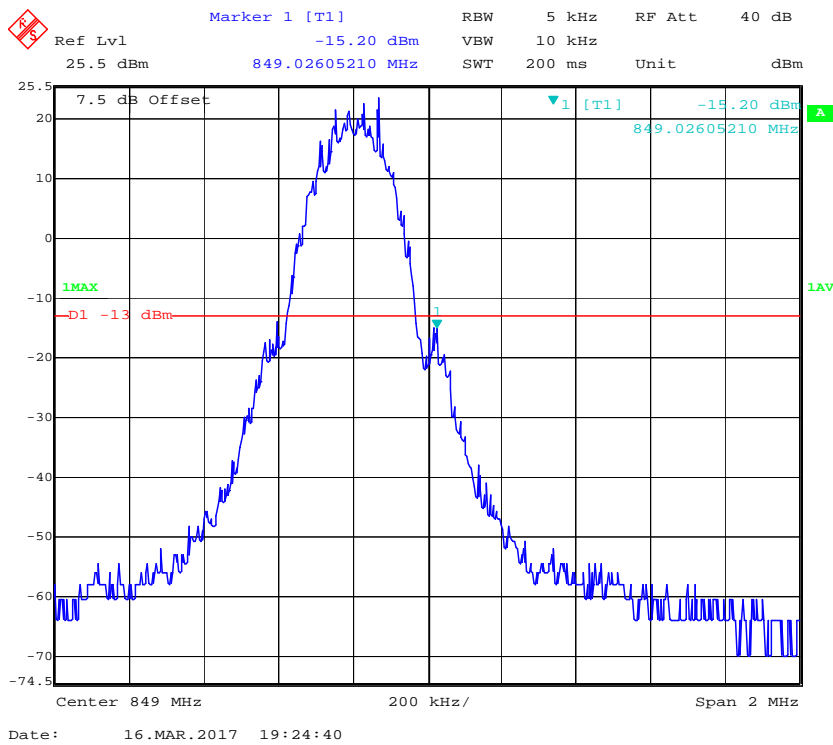

### Cellular Band, Left Band Edge for EGPRS (8PSK) Mode

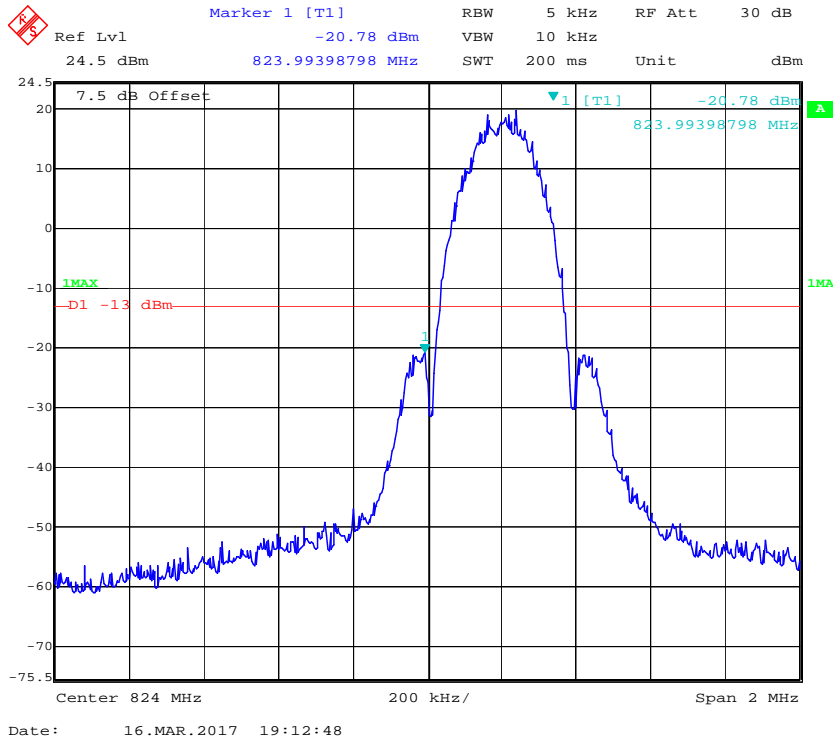

### Cellular Band, Right Band Edge for EGPRS (8PSK) Mode

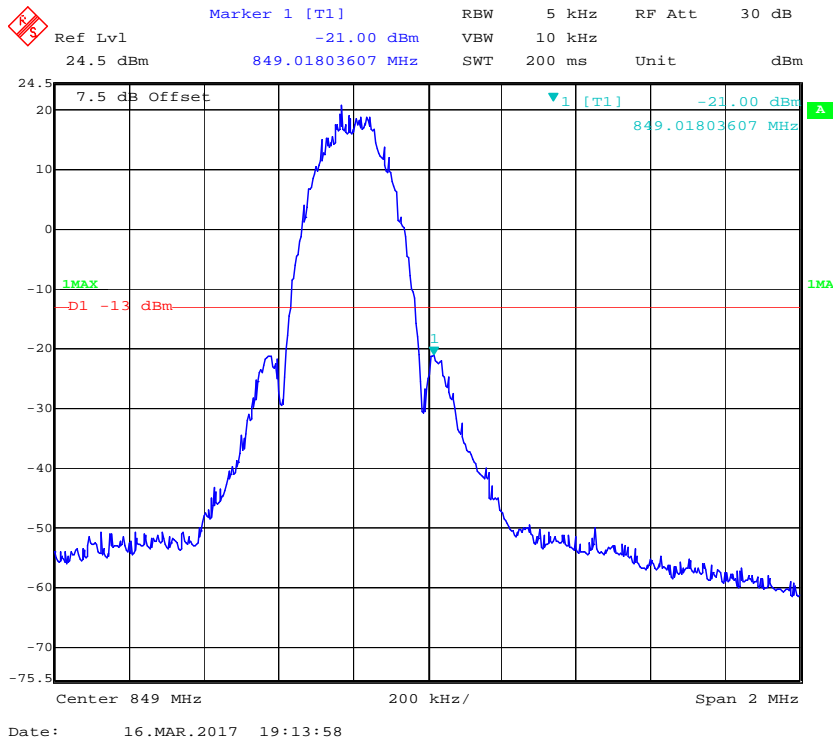

**Cellular Band, Left Band Edge for CDMA Mode**

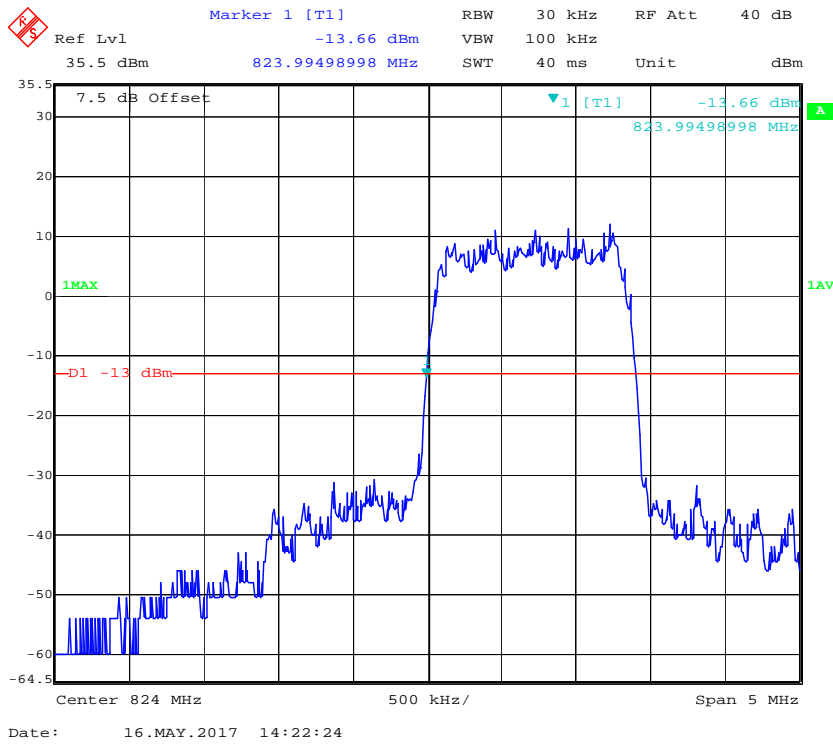

**Cellular Band, Right Band Edge for CDMA Mode**

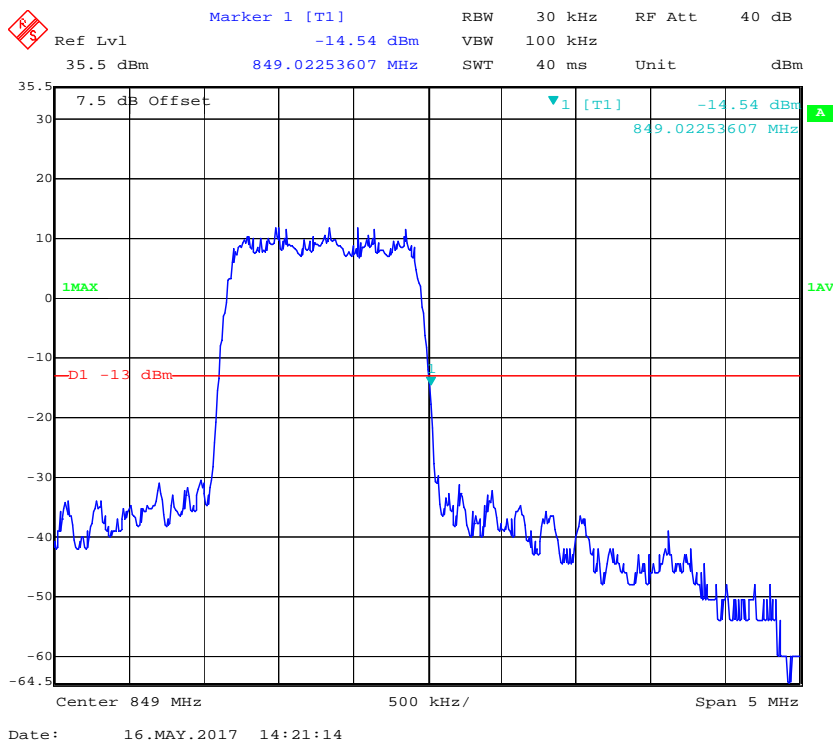



**Cellular Band, Left Band Edge for CDMA (EV-DO) Mode**

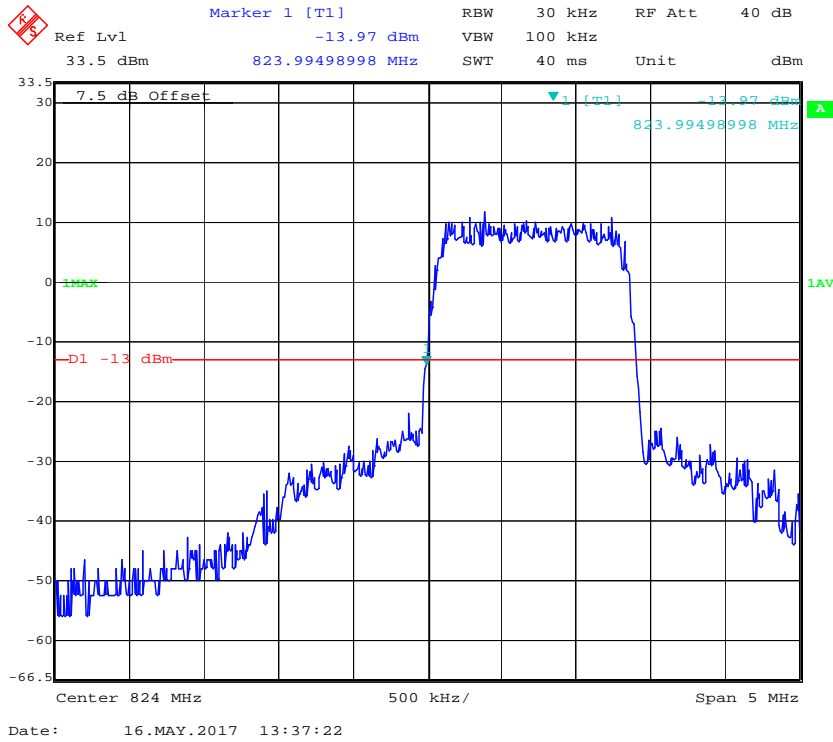

**Cellular Band, Right Band Edge for CDMA (EV-DO) Mode**

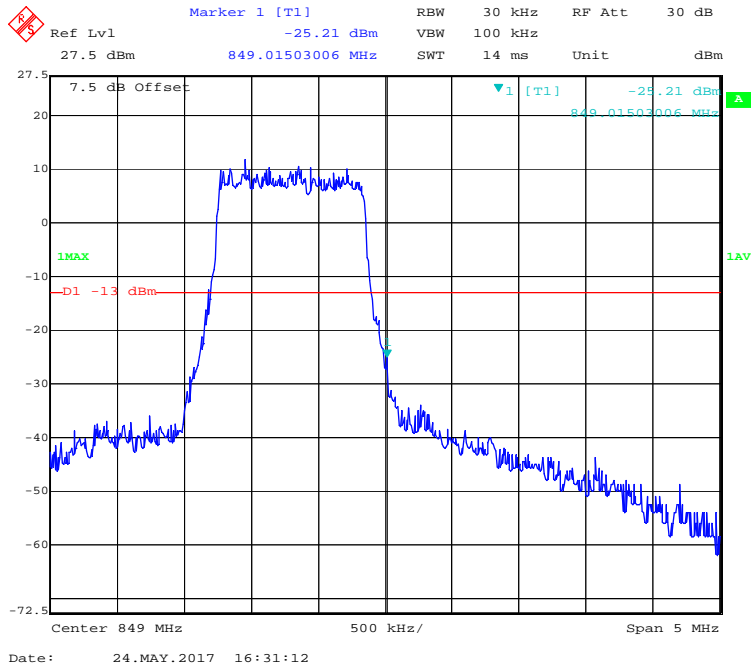

**PCS Band, Left Band Edge for GSM (GMSK) Mode**

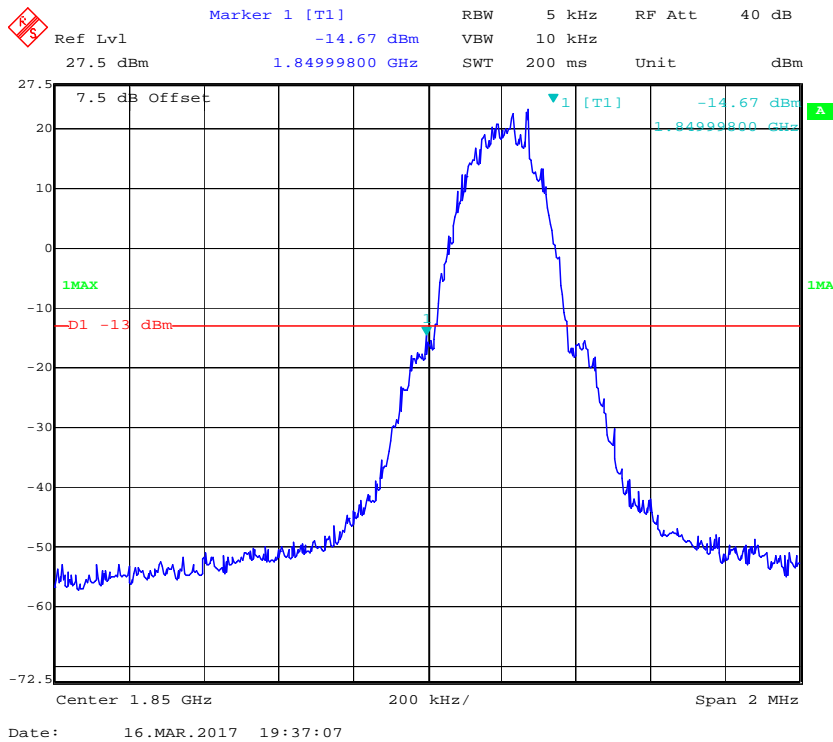

**PCS Band, Right Band Edge for GSM (GMSK) Mode**

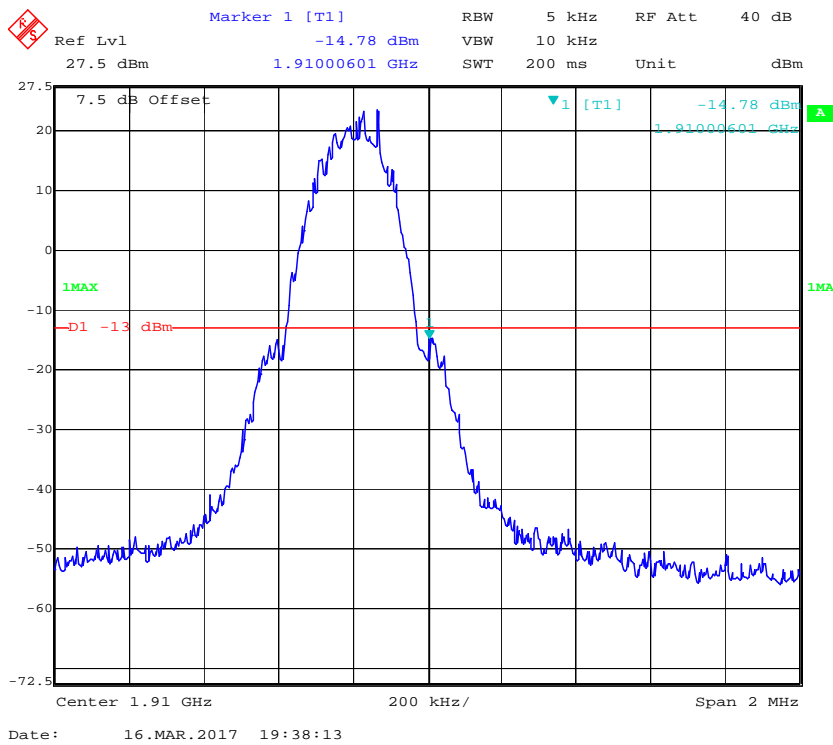

**PCS Band, Left Band Edge for EGPRS (8PSK) Mode**

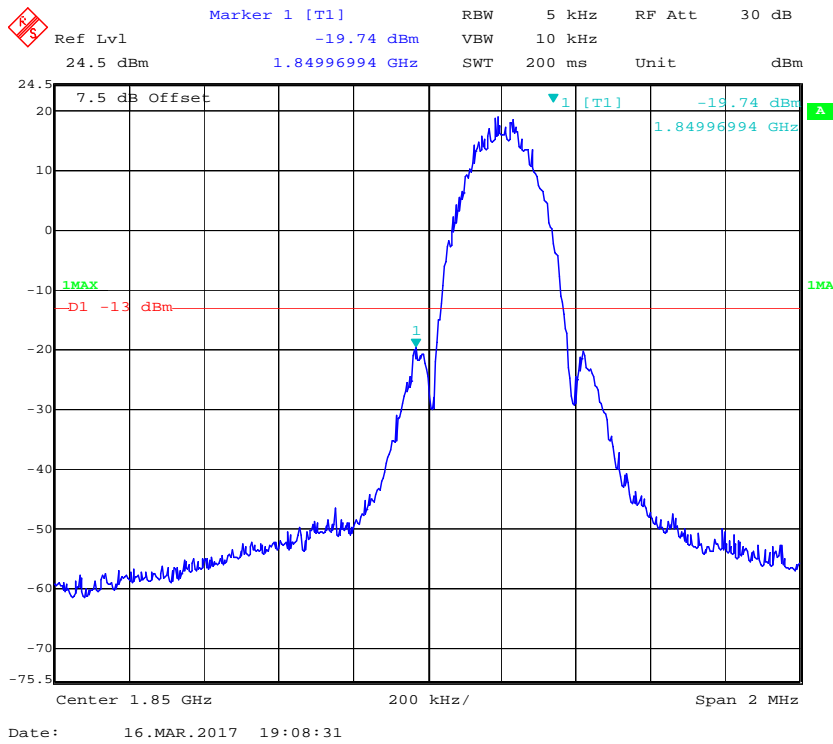

**PCS Band, Right Band Edge for EGPRS (8PSK) Mode**

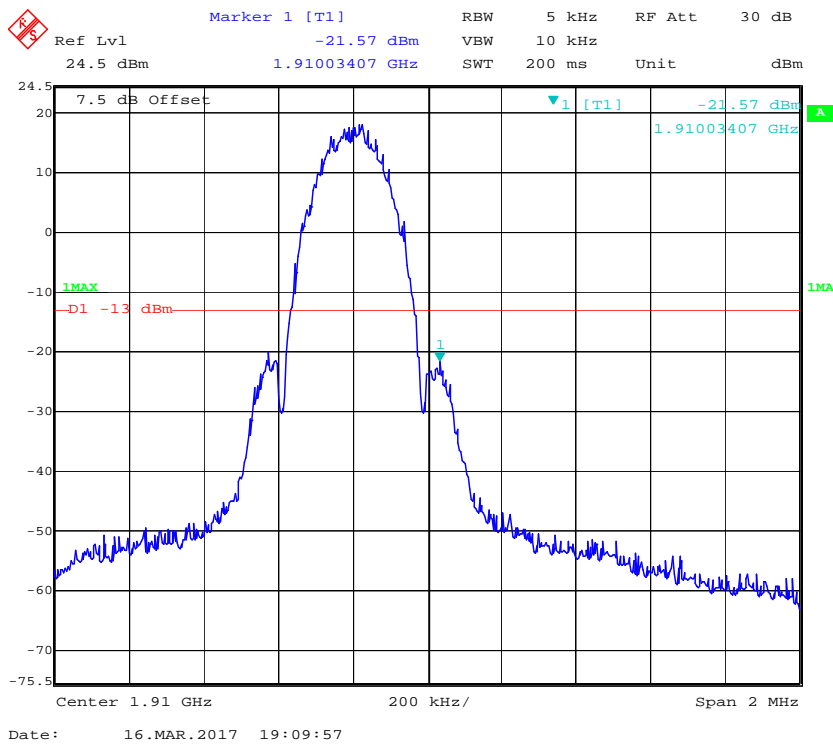

LTE Band 2:

QPSK (1.4 MHz, FULL RB) - Left Band Edge

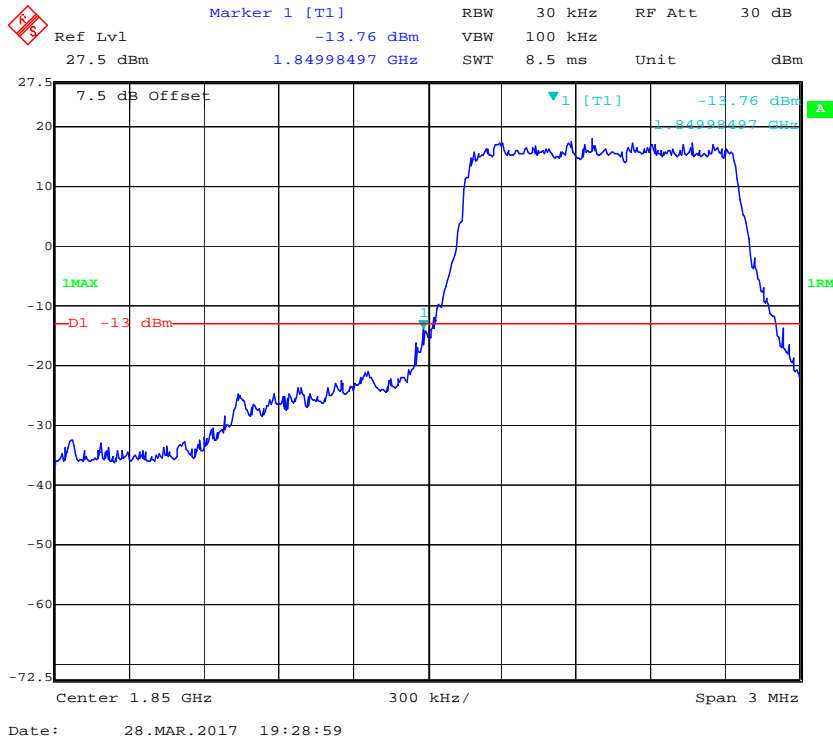

QPSK (1.4 MHz, FULL RB) - Right Band Edge

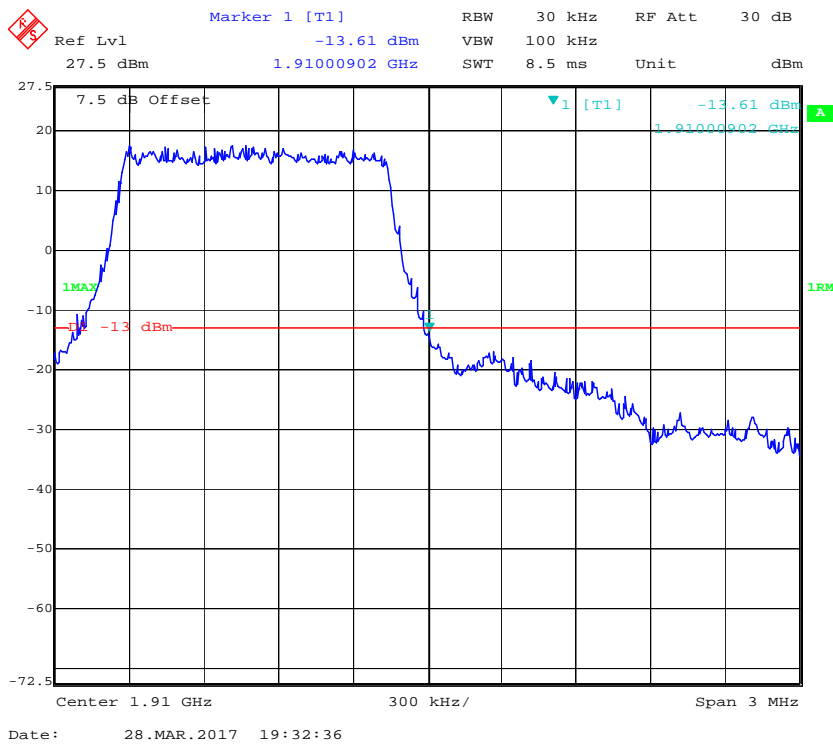

### 16-QAM (1.4 MHz, FULL RB) - Left Band Edge

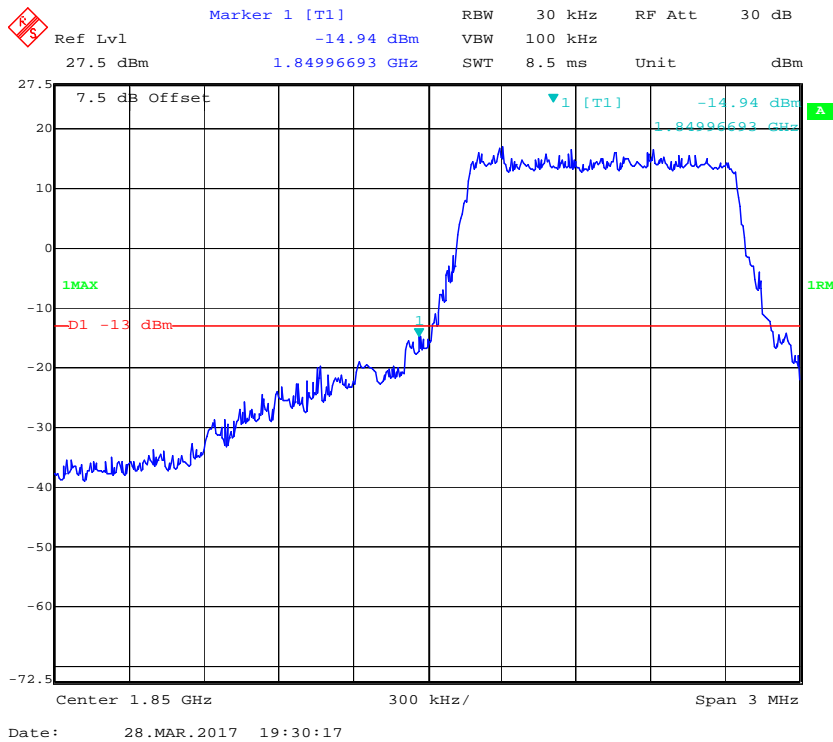

### 16-QAM (1.4 MHz, FULL RB) - Right Band Edge

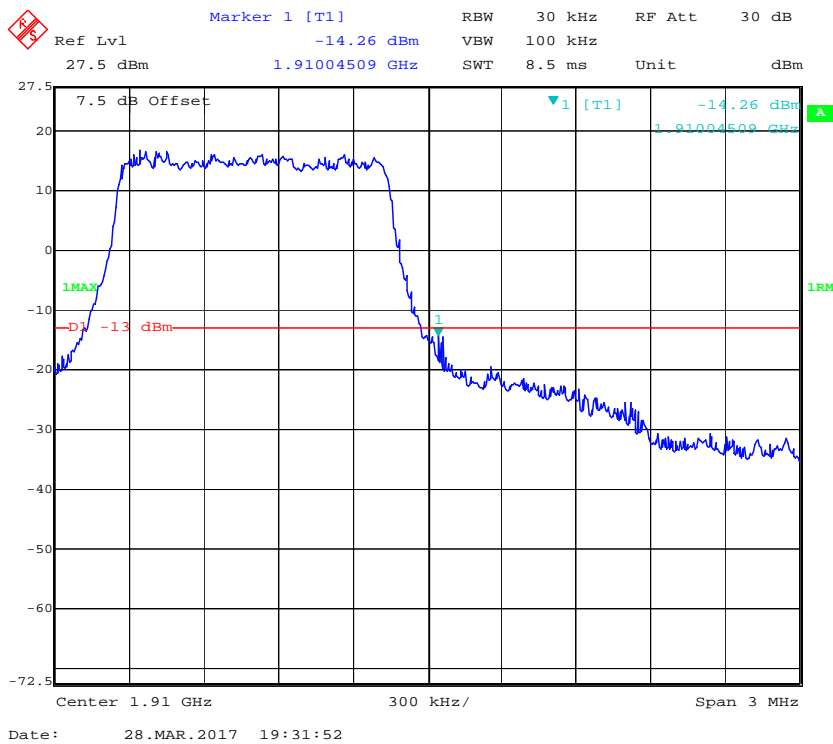

### QPSK (3.0 MHz, FULL RB) - Left Band Edge

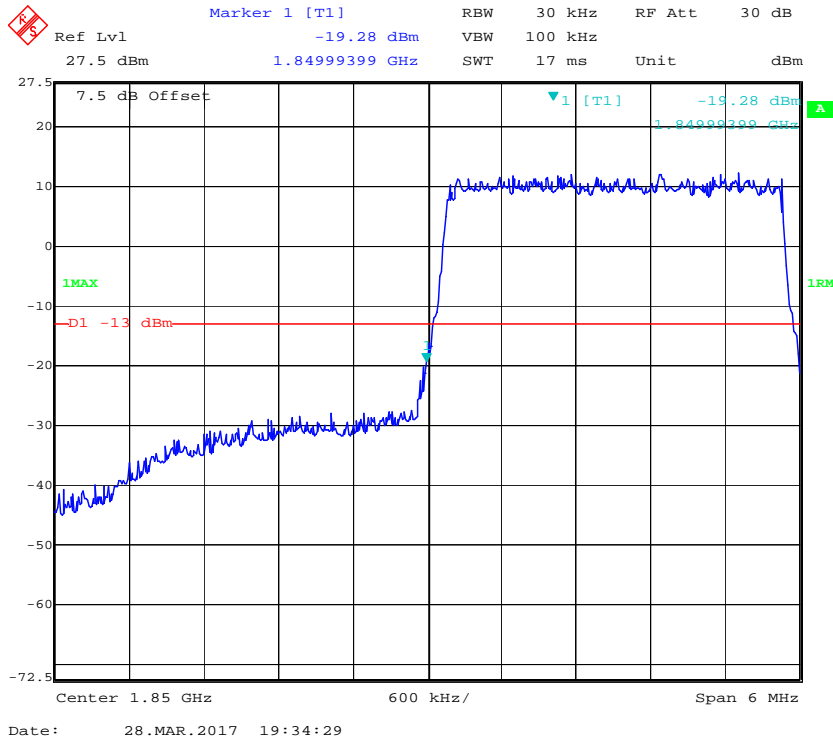

### QPSK (3.0 MHz, FULL RB) - Right Band Edge

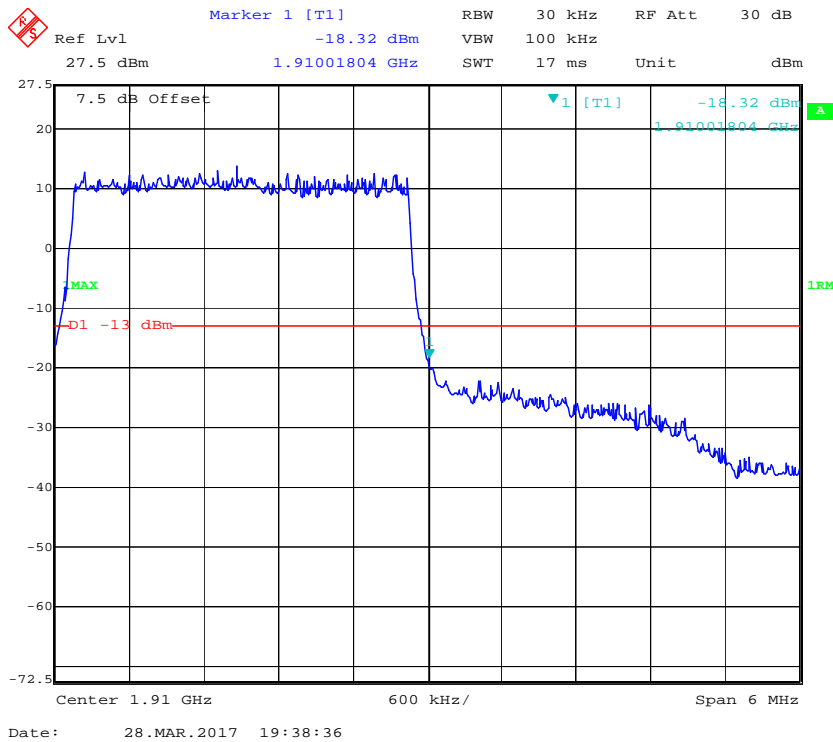

### 16-QAM (3.0 MHz, FULL RB) - Left Band Edge

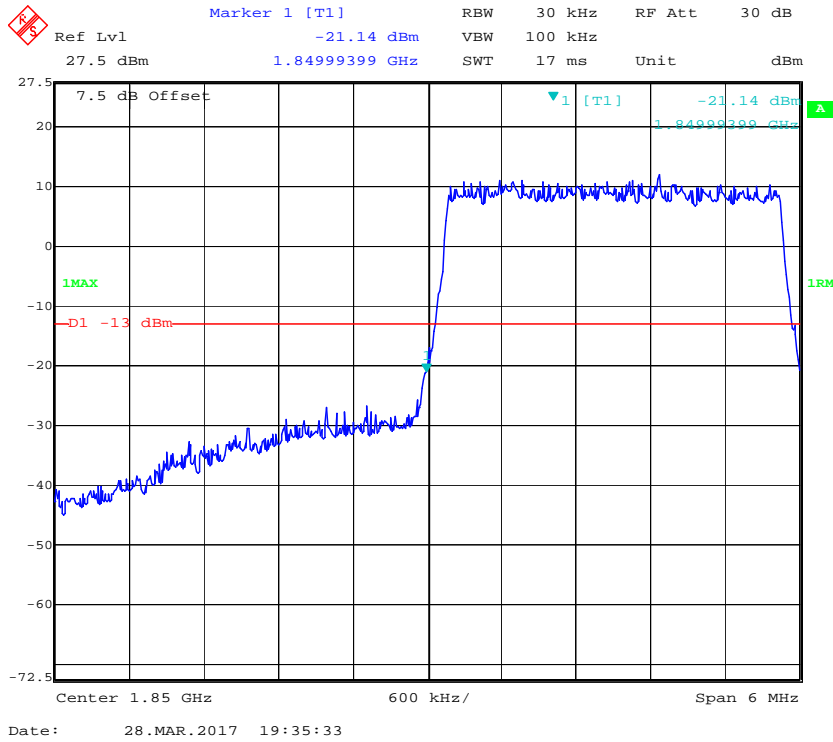

### 16-QAM (3.0 MHz, FULL RB) - Right Band Edge

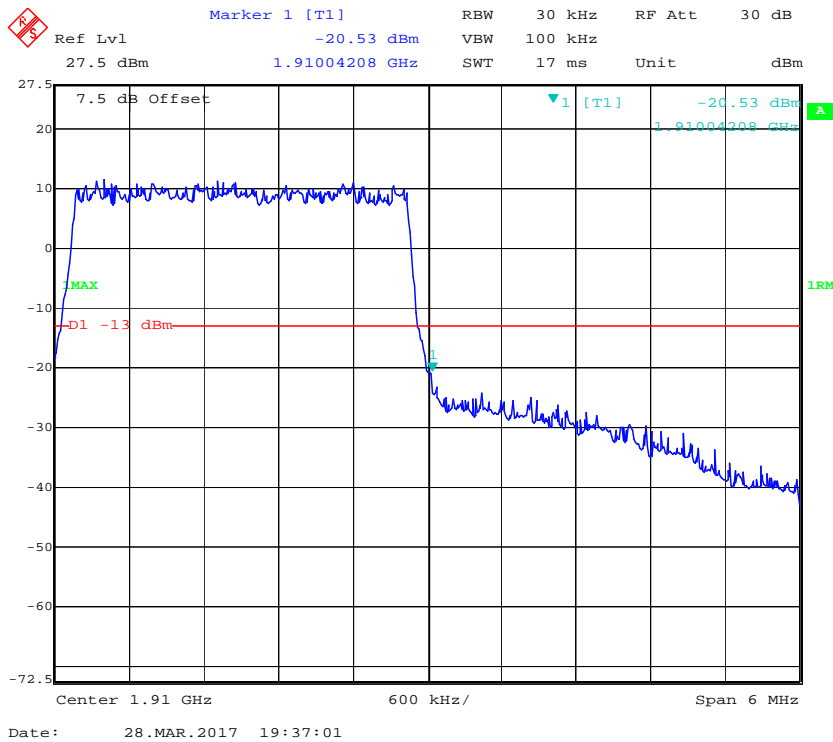

### QPSK (5.0 MHz, FULL RB) - Left Band Edge

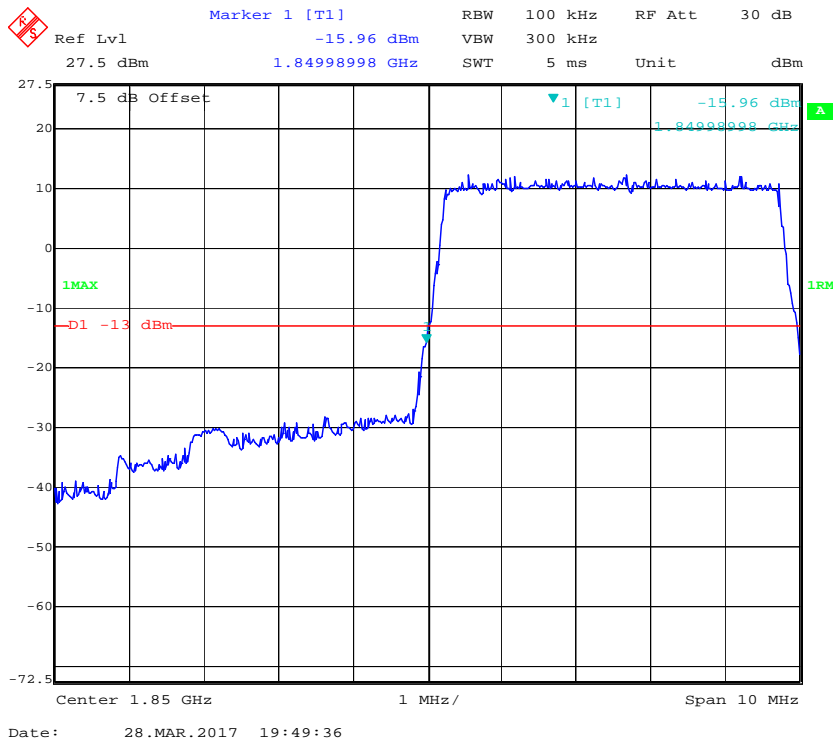

### QPSK (5.0 MHz, FULL RB) - Right Band Edge

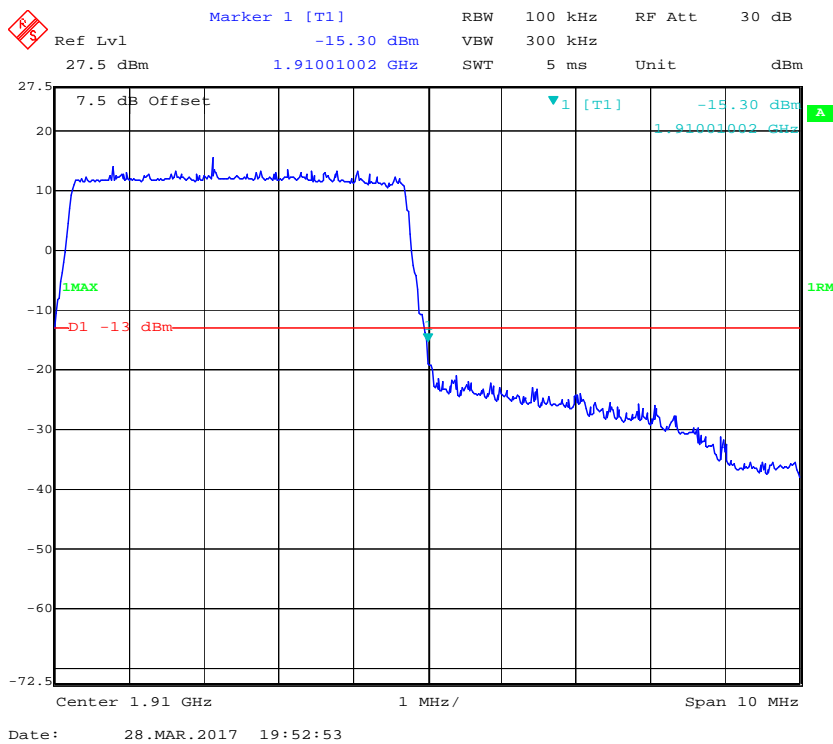



### 16-QAM (5.0 MHz, FULL RB) - Left Band Edge

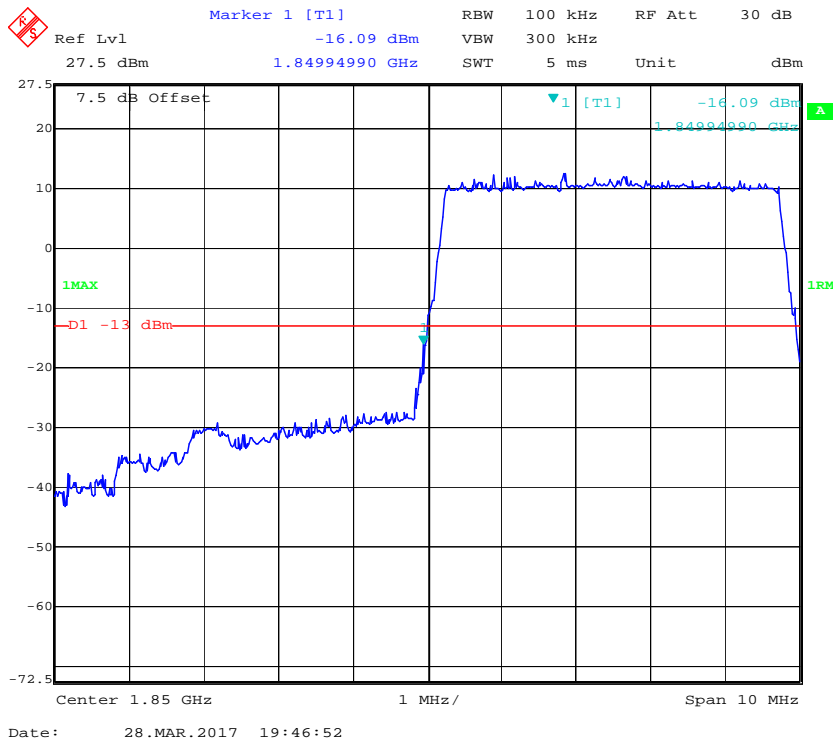

### 16-QAM (5.0 MHz, FULL RB) - Right Band Edge

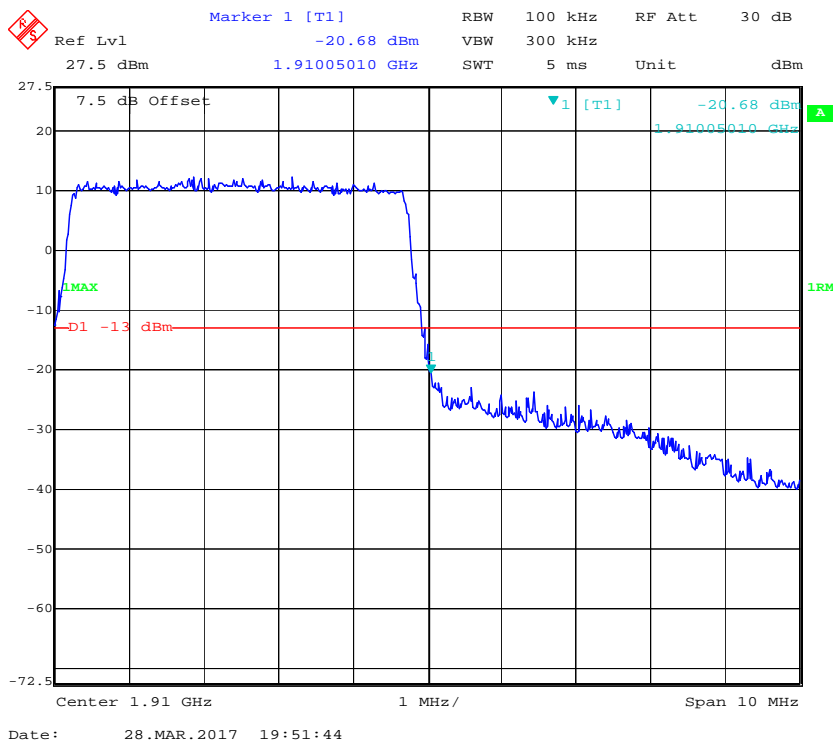

### QPSK (10.0 MHz, FULL RB) - Left Band Edge

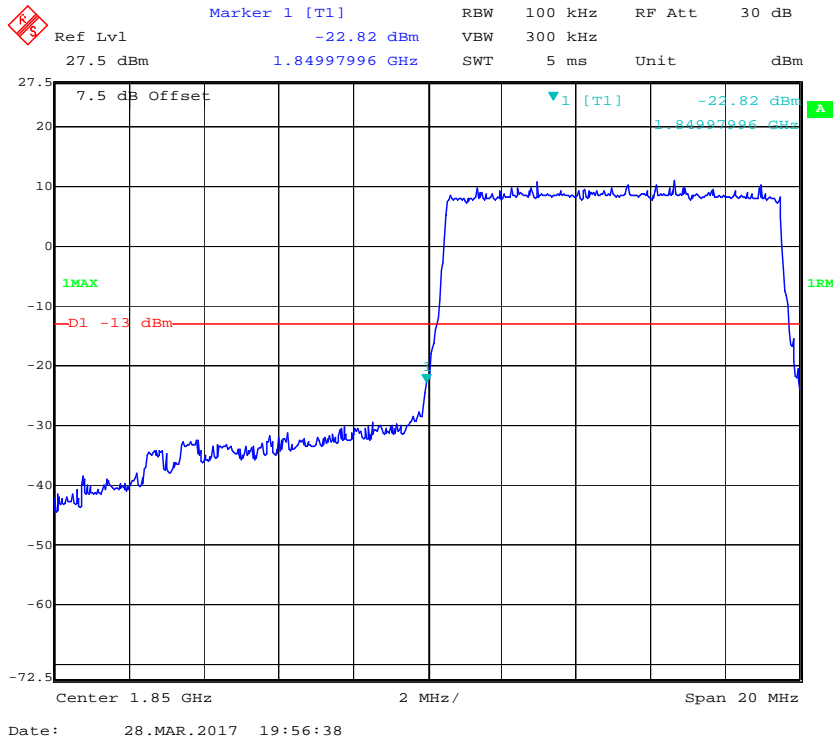

### QPSK (10.0 MHz, FULL RB) - Right Band Edge

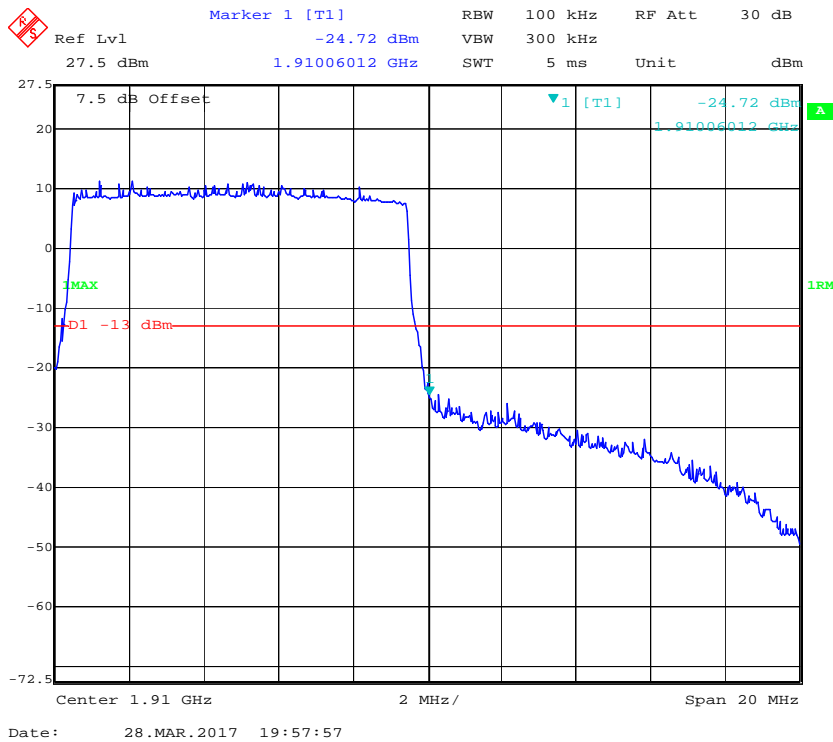

**16-QAM (10.0 MHz, FULL RB) - Left Band Edge**

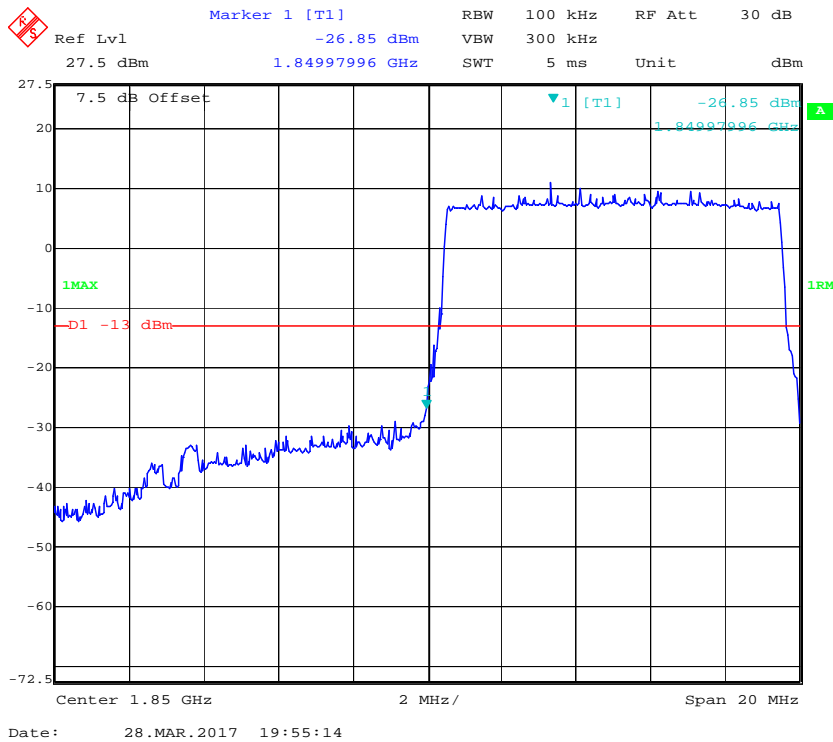

**16-QAM (10.0 MHz, FULL RB) - Right Band Edge**

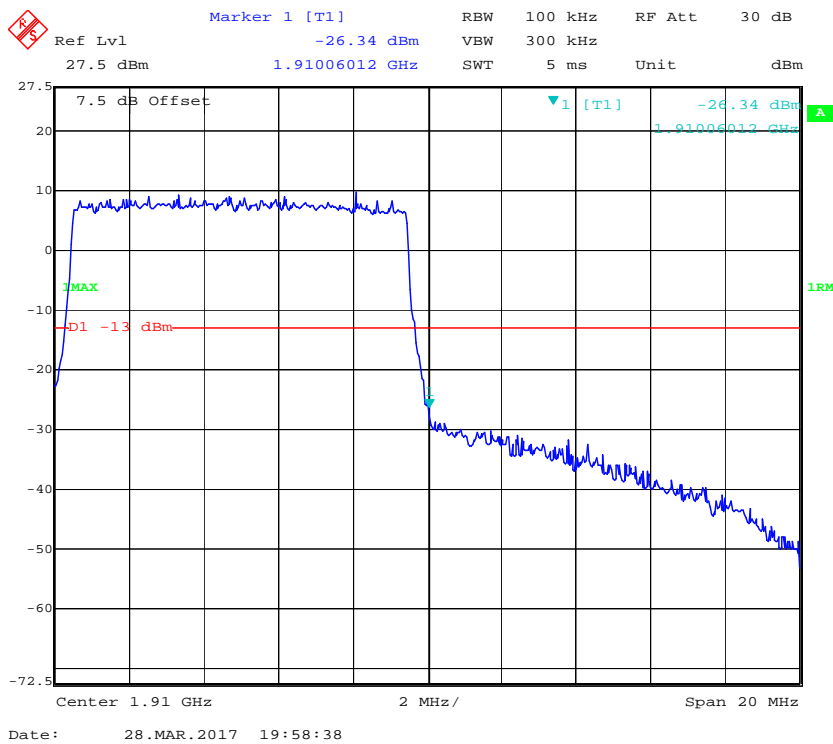

**QPSK (15.0 MHz, FULL RB) - Left Band Edge**

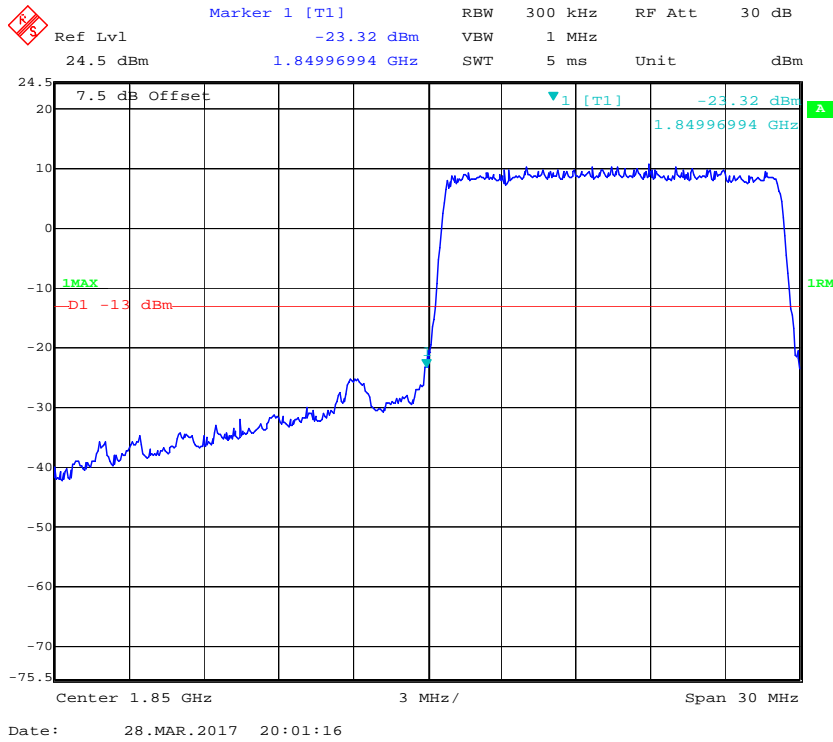

**QPSK (15.0 MHz, FULL RB) - Right Band Edge**

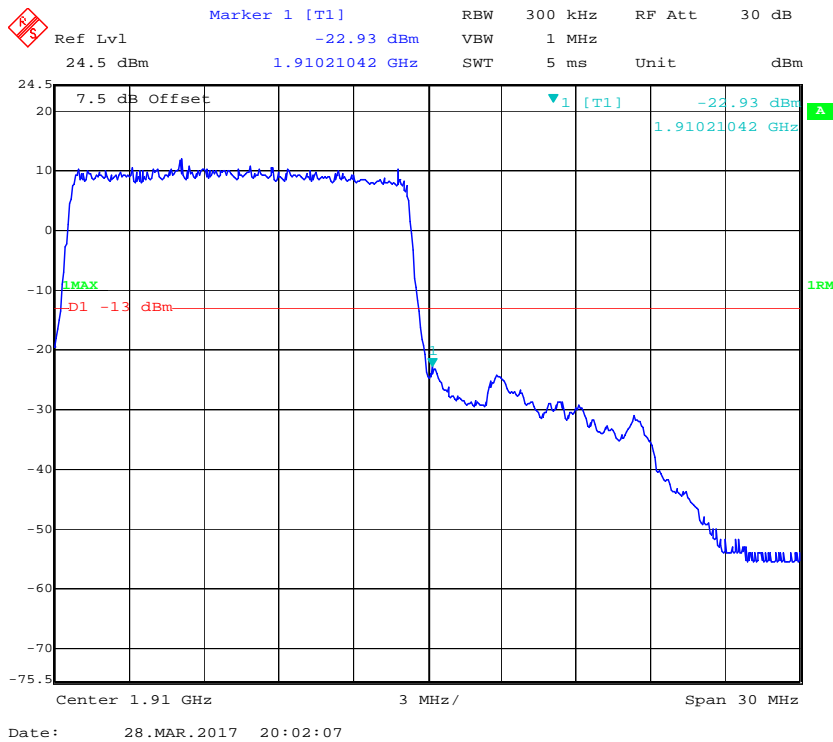

### 16-QAM (15.0 MHz, FULL RB) - Left Band Edge

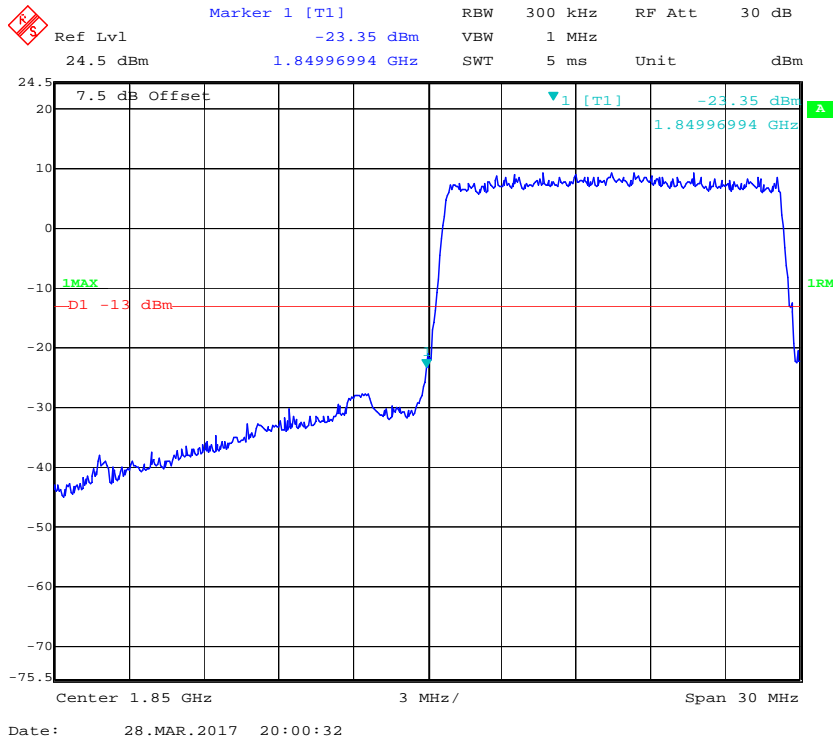

### 16-QAM (15.0 MHz, FULL RB) - Right Band Edge

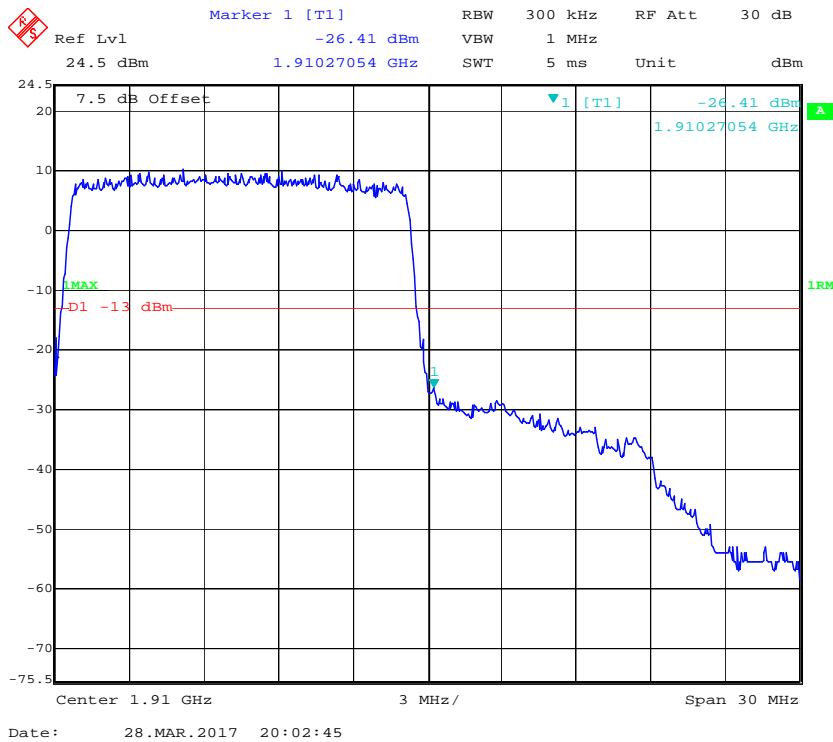

### QPSK (20.0 MHz, FULL RB) - Left Band Edge

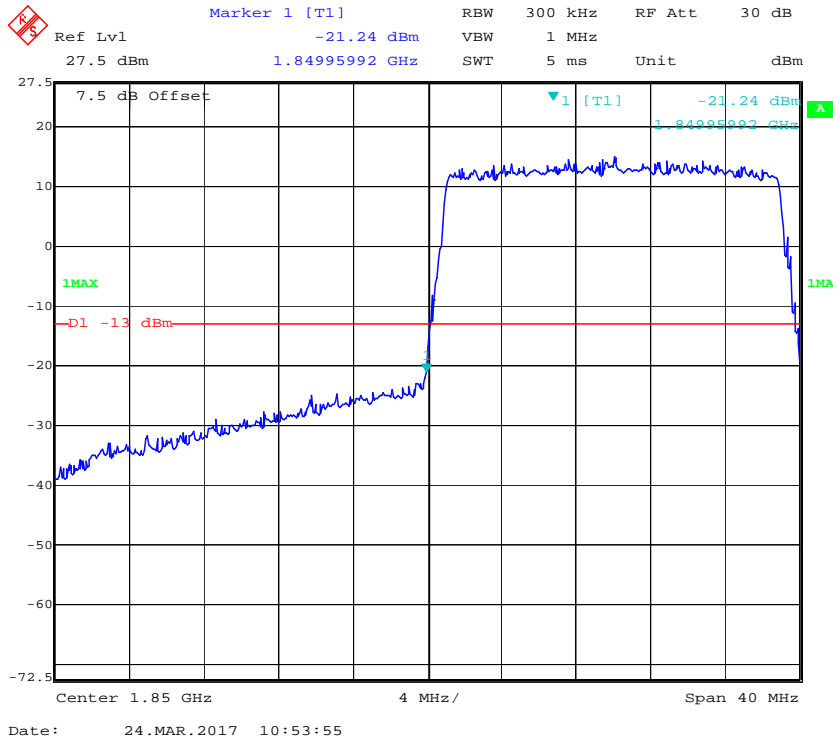

### QPSK (20.0 MHz, FULL RB) - Right Band Edge

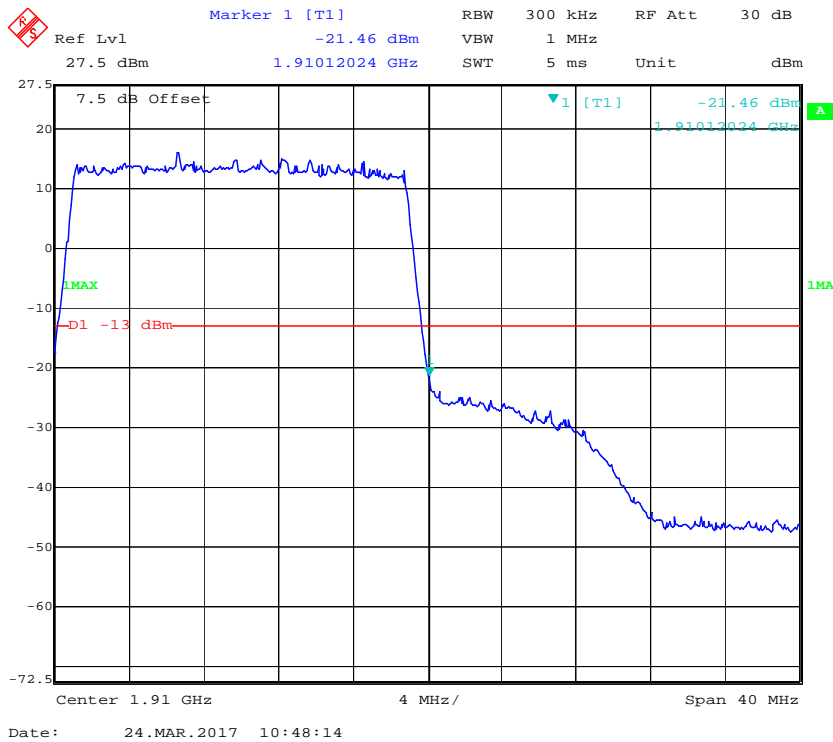

### 16-QAM (20.0 MHz, FULL RB) - Left Band Edge

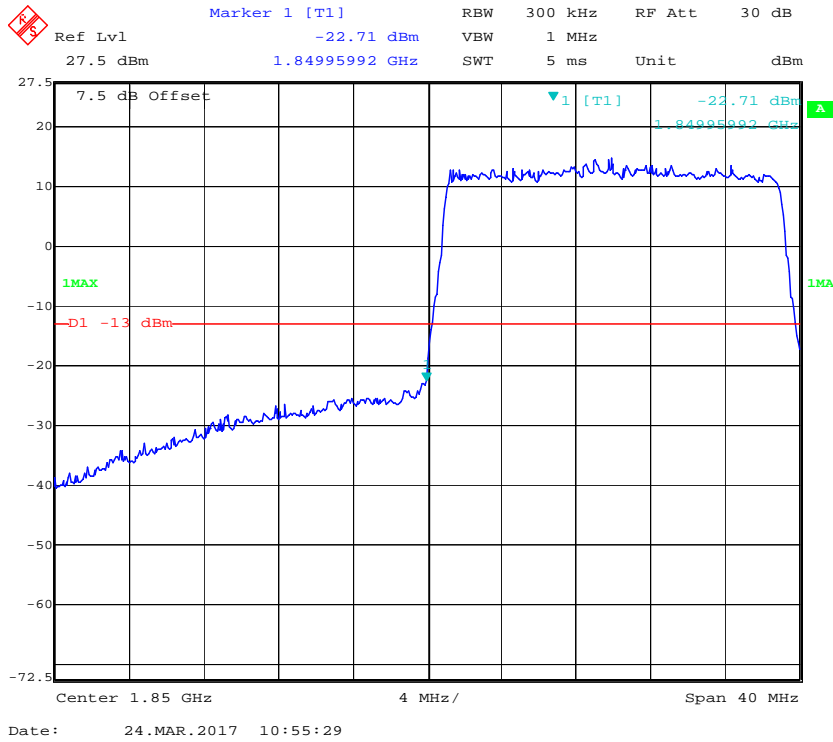

### 16-QAM (20.0 MHz, FULL RB) - Right Band Edge

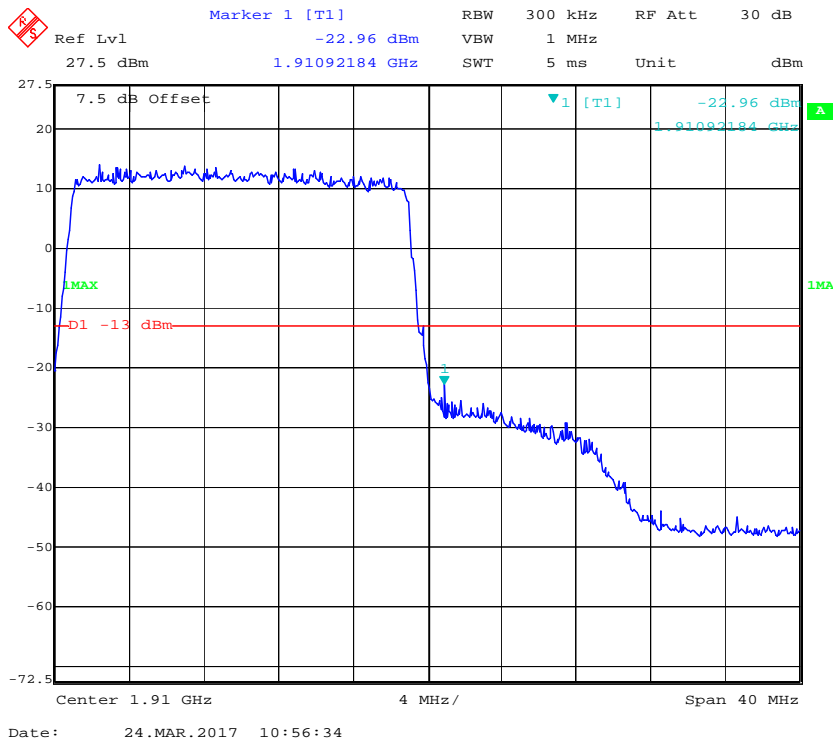

LTE Band 4:

QPSK (1.4 MHz, FULL RB) - Left Band Edge

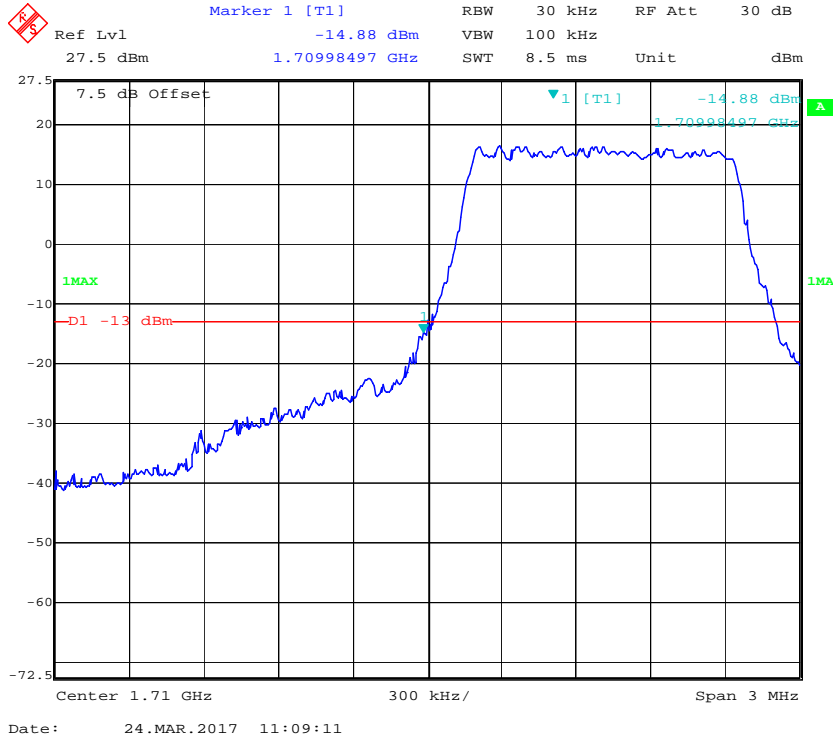

QPSK (1.4 MHz, FULL RB) - Right Band Edge

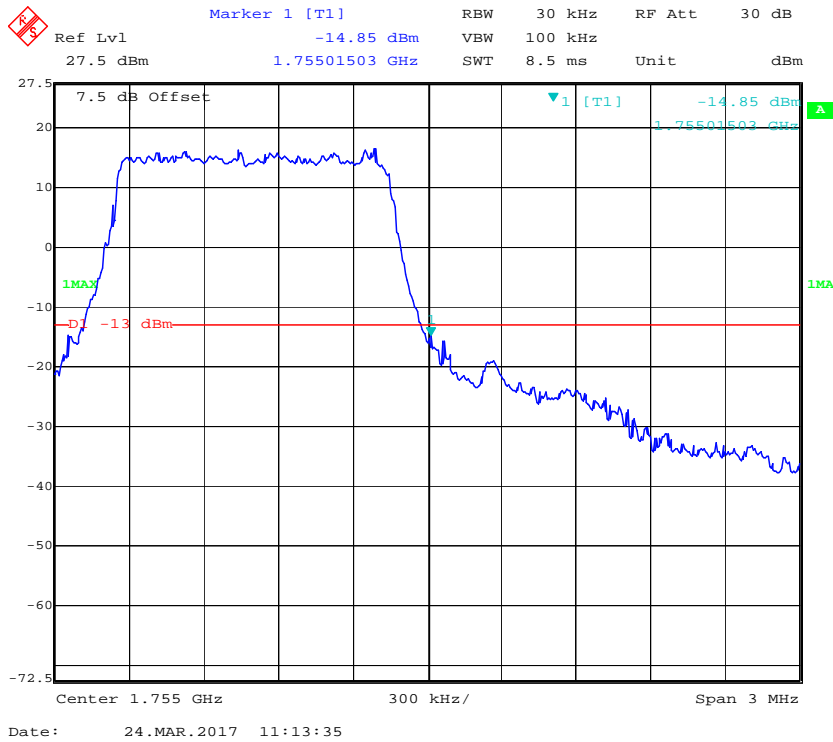



### 16-QAM (1.4 MHz, FULL RB) - Left Band Edge

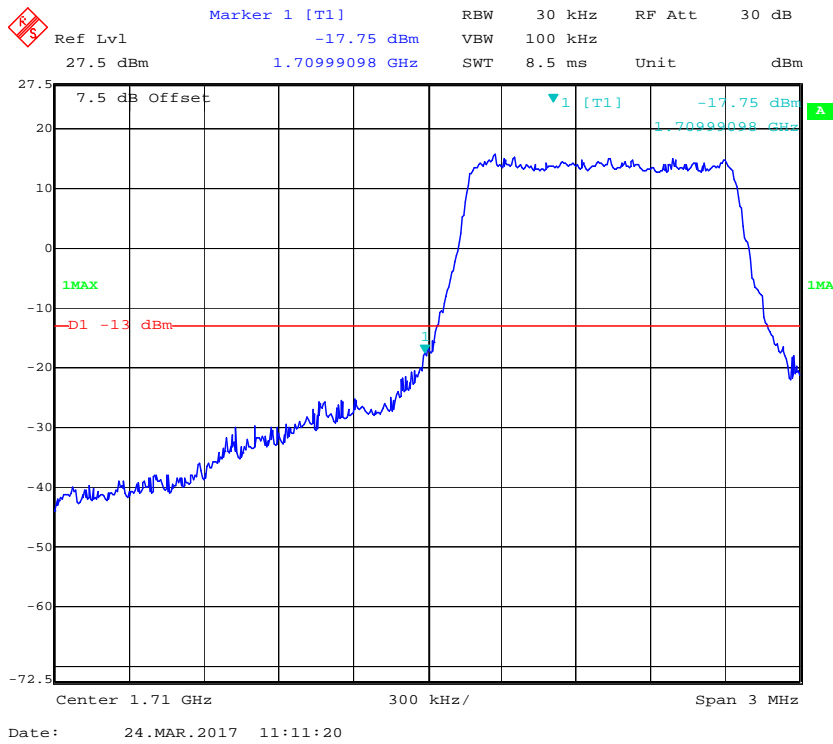

### 16-QAM (1.4 MHz, FULL RB) - Right Band Edge

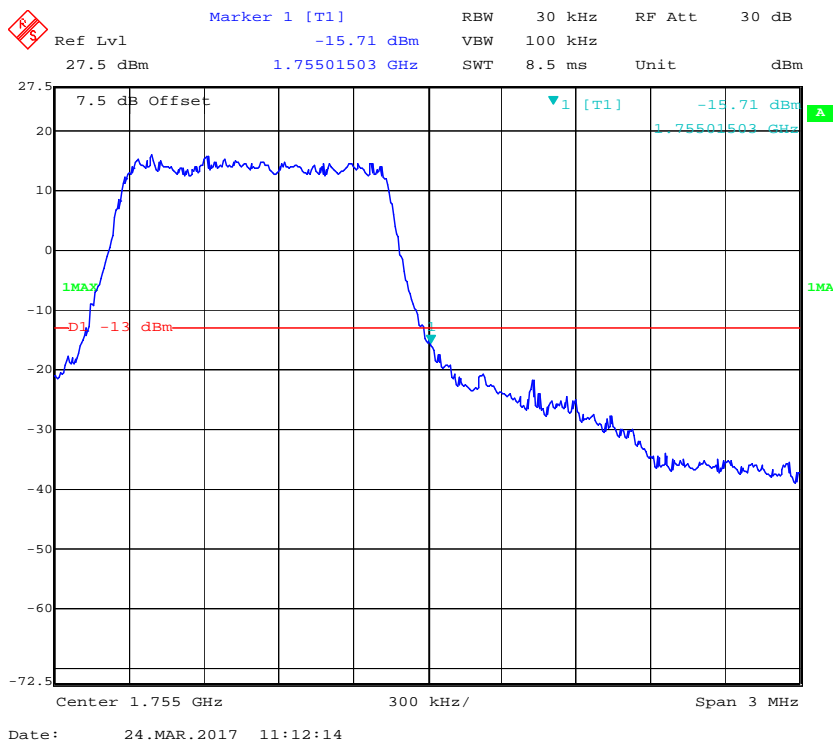

### QPSK (3.0 MHz, FULL RB) - Left Band Edge

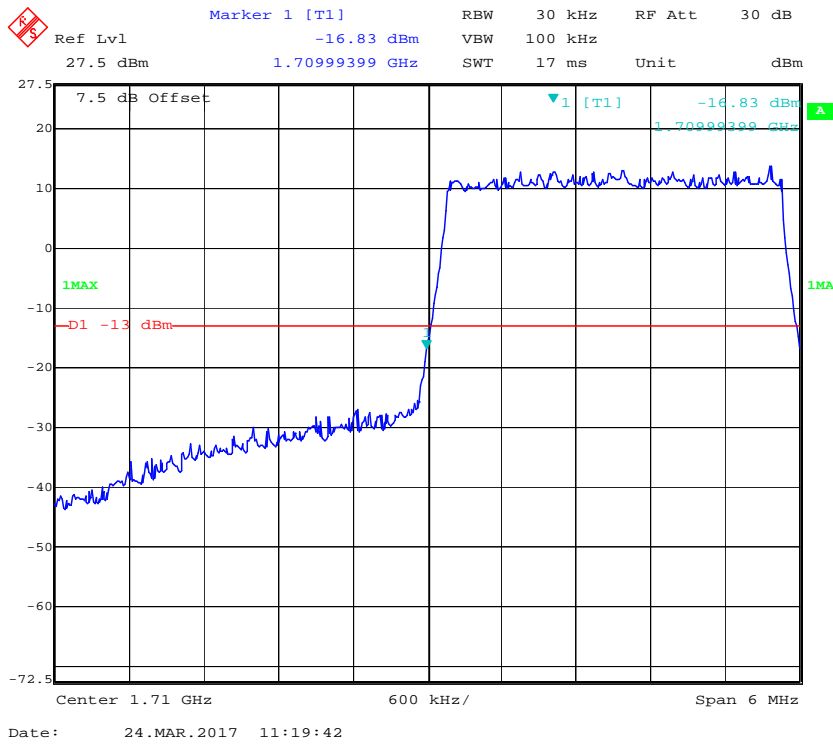

### QPSK (3.0 MHz, FULL RB) - Right Band Edge

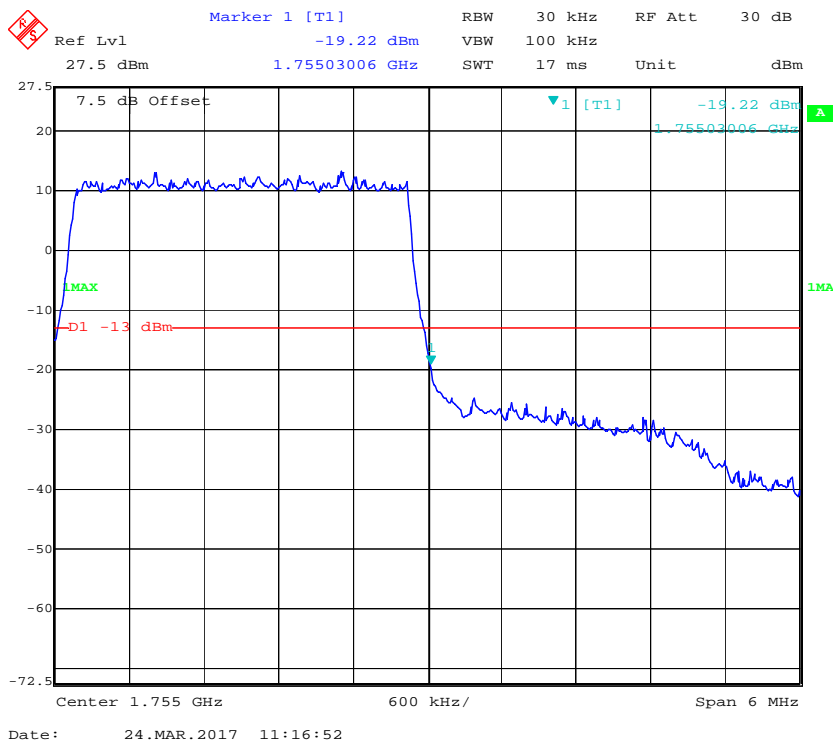

### 16-QAM (3.0 MHz, FULL RB) - Left Band Edge

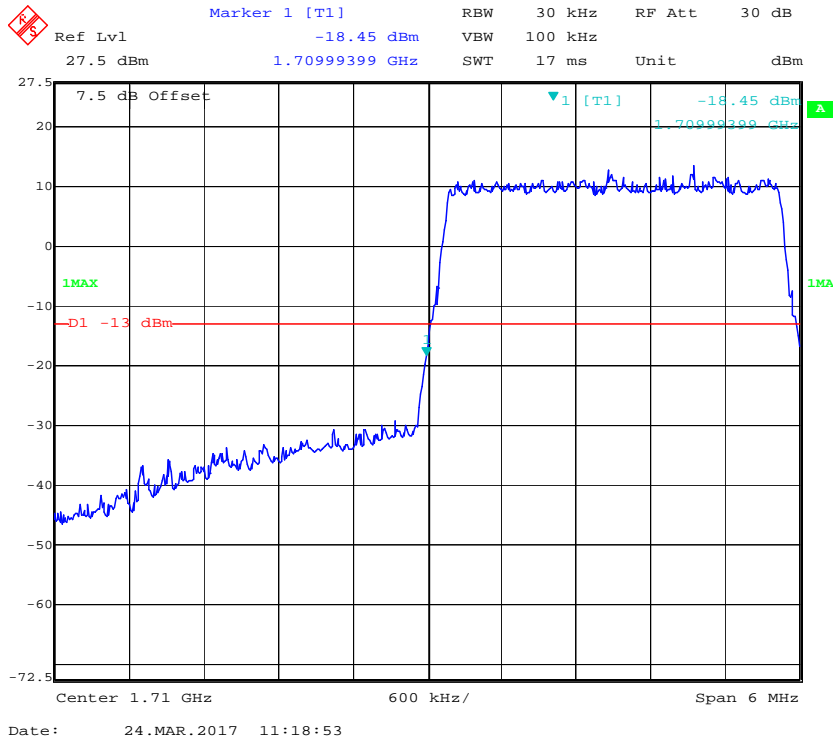

### 16-QAM (3.0 MHz, FULL RB) - Right Band Edge

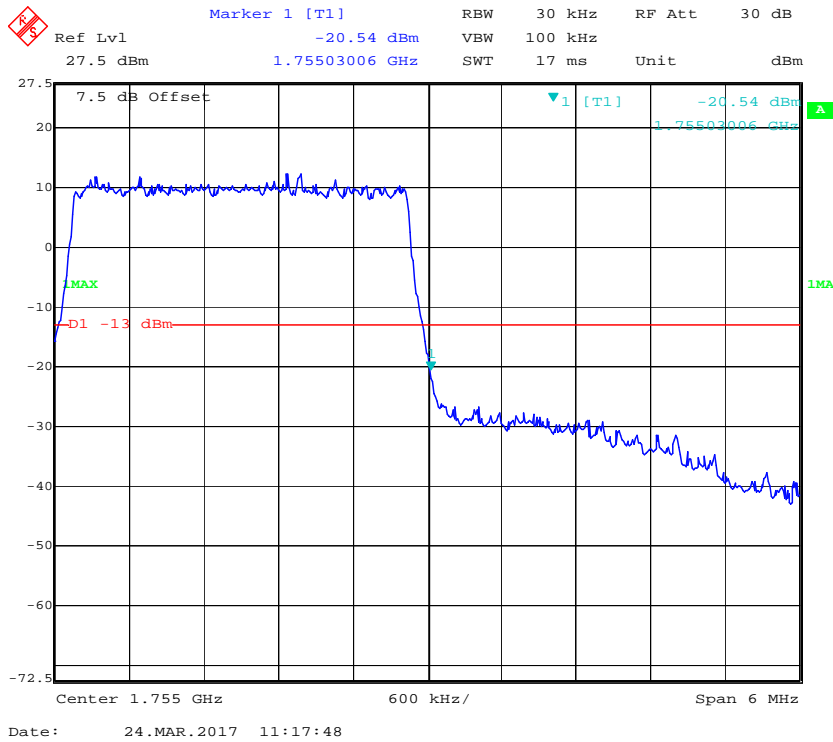

### QPSK (5.0 MHz, FULL RB) - Left Band Edge

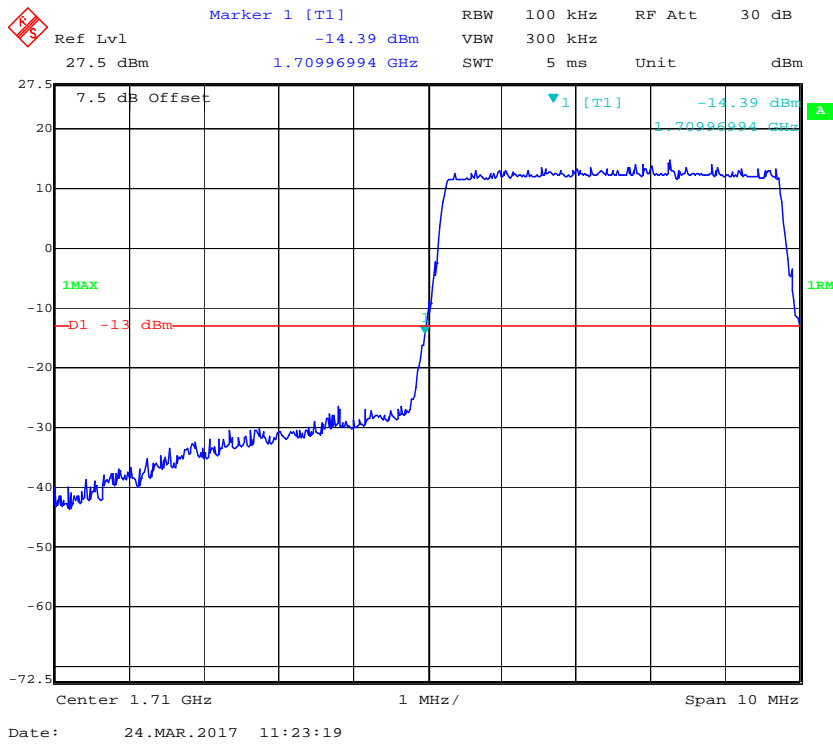

### QPSK (5.0 MHz, FULL RB) - Right Band Edge

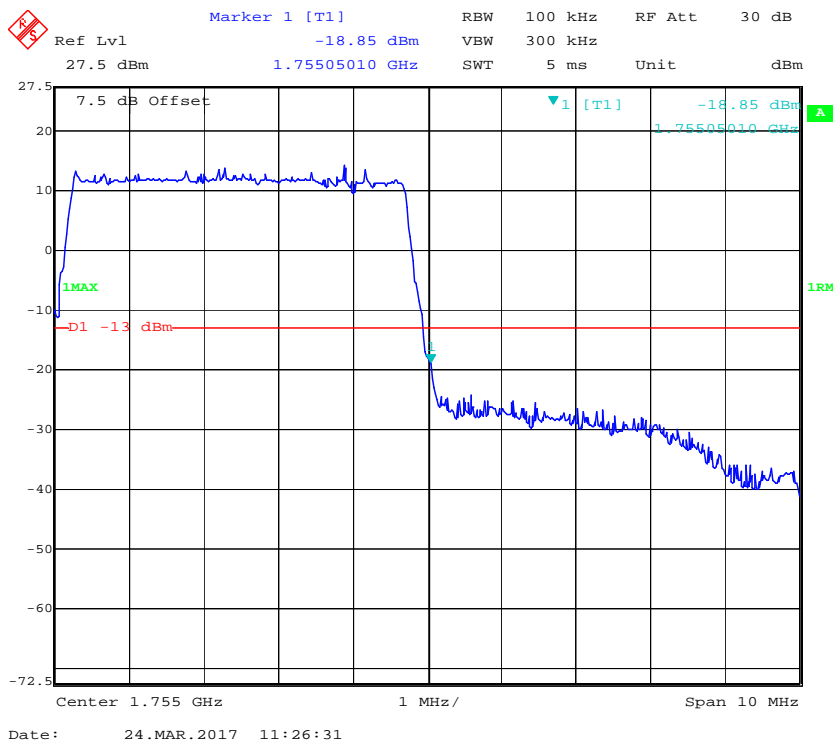

**16-QAM (5.0 MHz, FULL RB) - Left Band Edge**

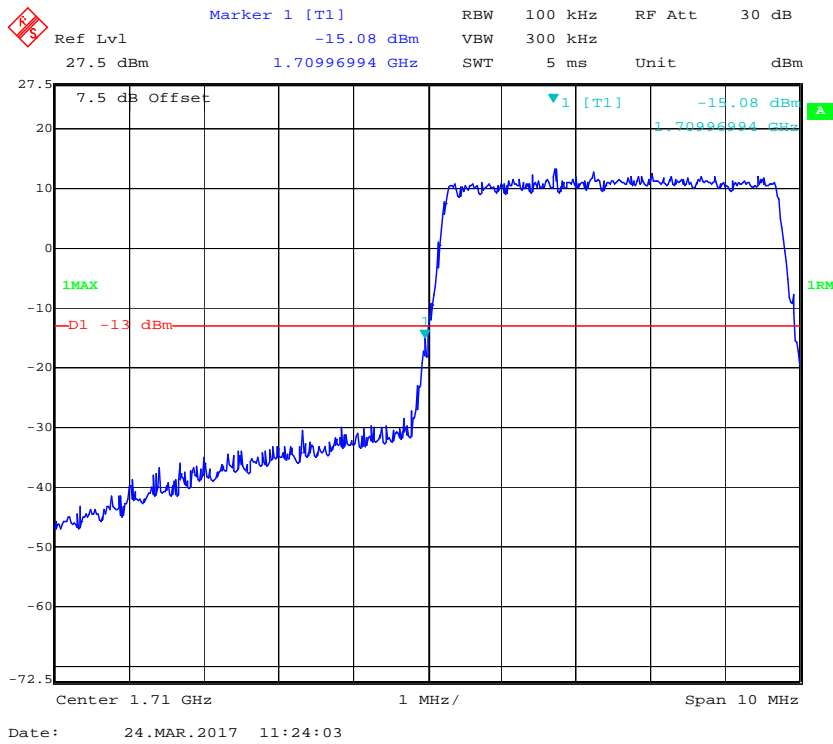

**16-QAM (5.0 MHz, FULL RB) - Right Band Edge**

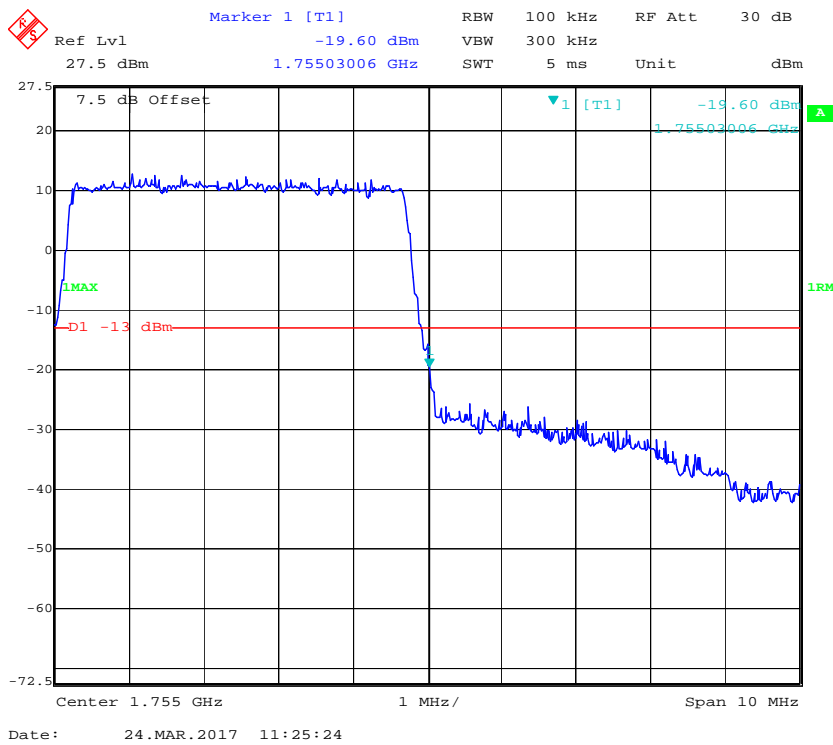

**QPSK (10.0 MHz, FULL RB) - Left Band Edge**

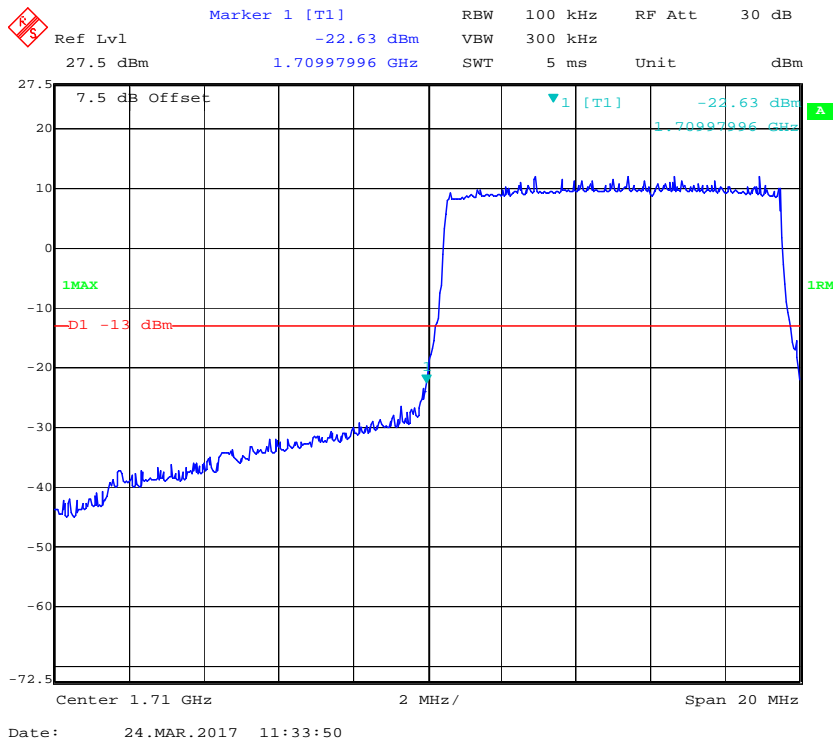

**QPSK (10.0 MHz, FULL RB) - Right Band Edge**

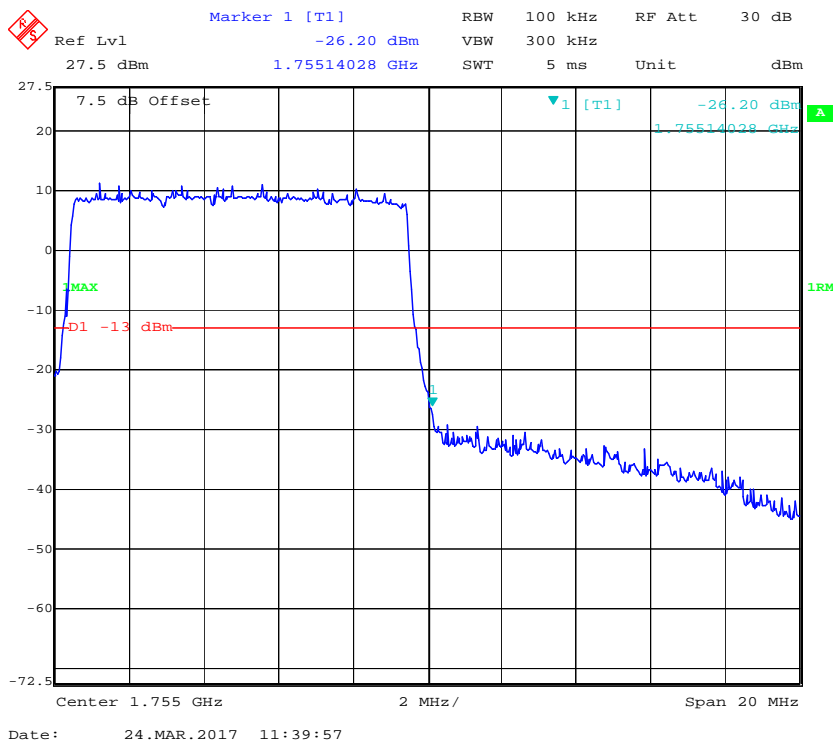

### 16-QAM (10.0 MHz, FULL RB) - Left Band Edge

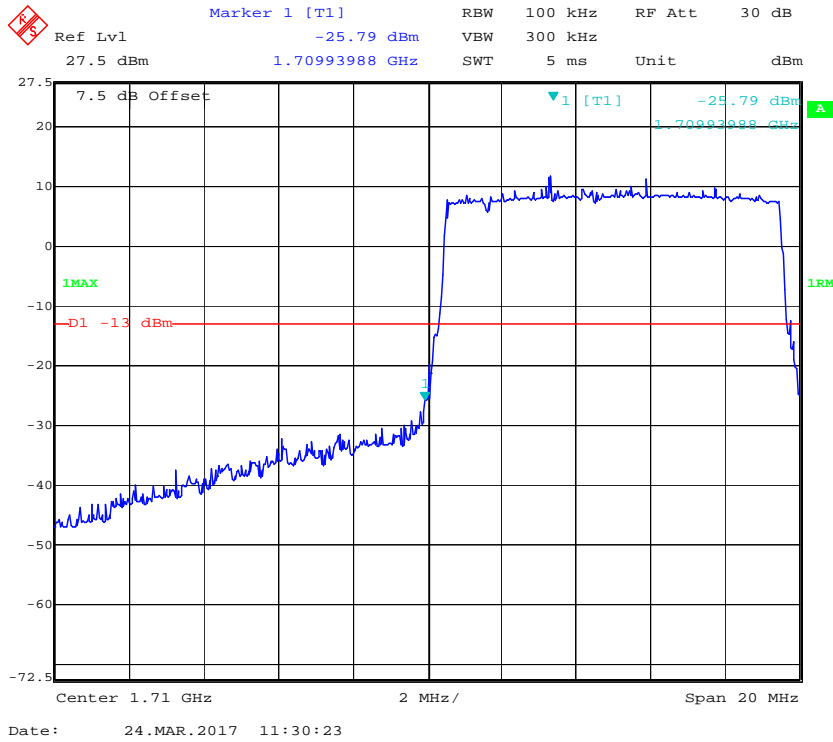

### 16-QAM (10.0 MHz, FULL RB) - Right Band Edge

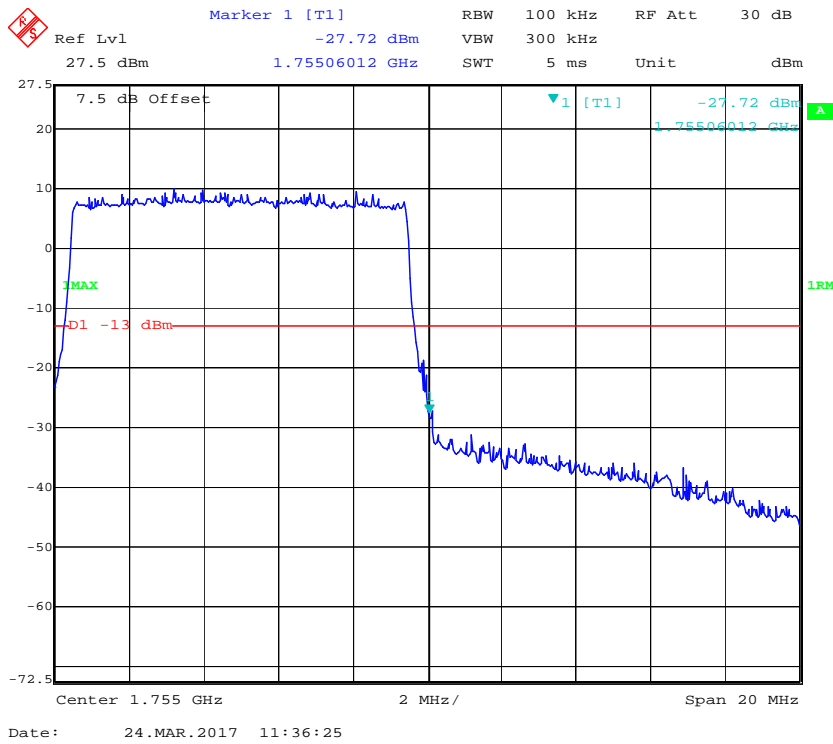

**QPSK (15.0 MHz, FULL RB) - Left Band Edge**

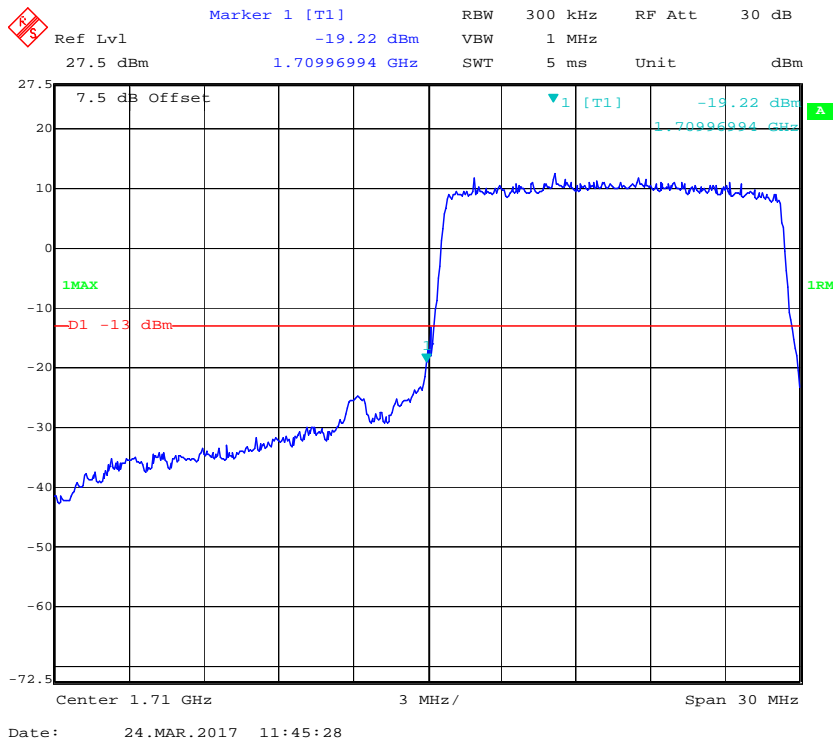

**QPSK (15.0 MHz, FULL RB) - Right Band Edge**

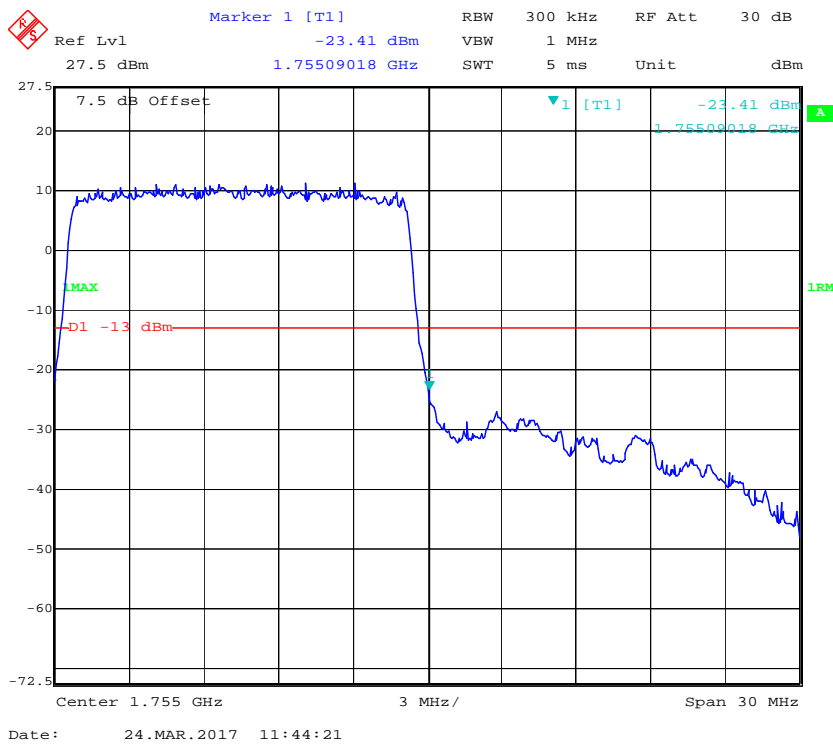



### 16-QAM (15.0 MHz, FULL RB) - Left Band Edge

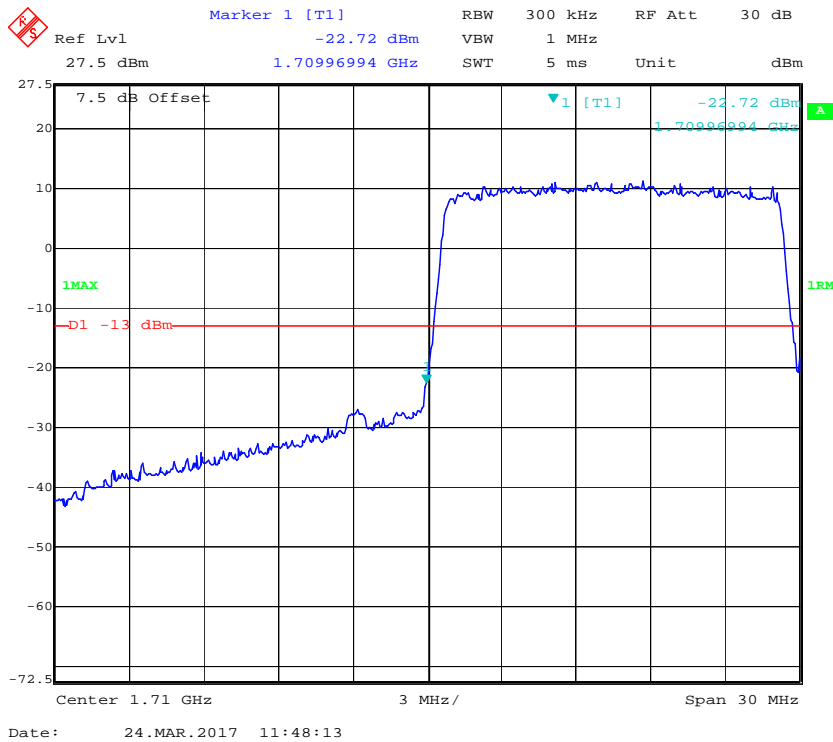

### 16-QAM (15.0 MHz, FULL RB) - Right Band Edge

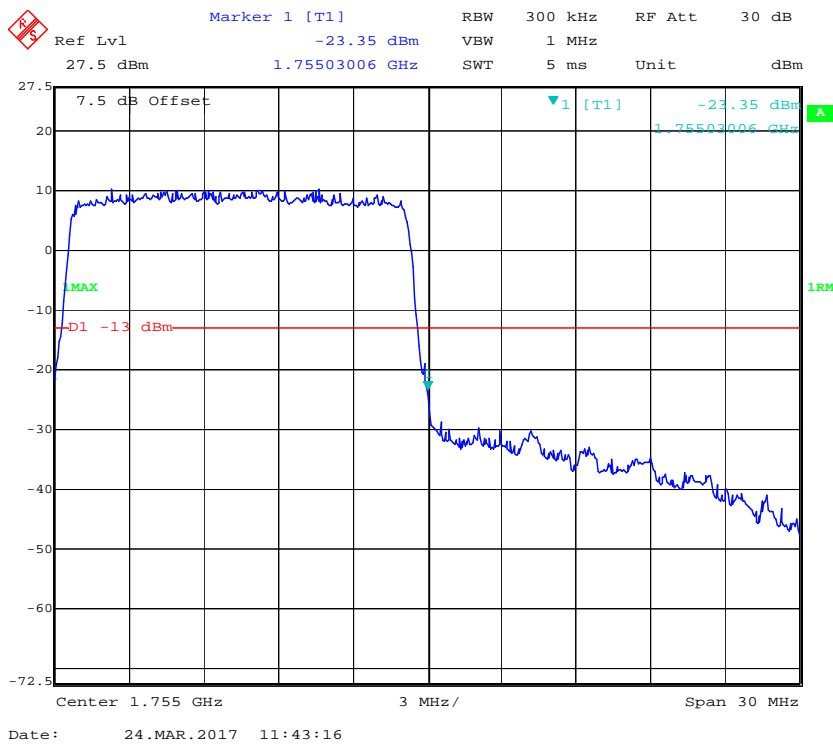

**QPSK (20.0 MHz, FULL RB) - Left Band Edge**

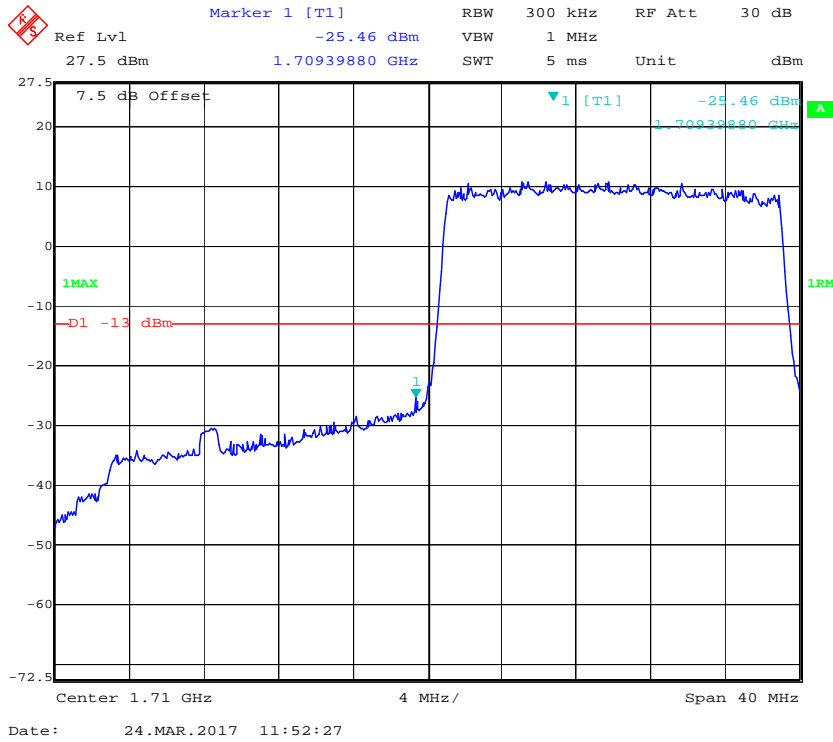

**QPSK (20.0 MHz, FULL RB) - Right Band Edge**

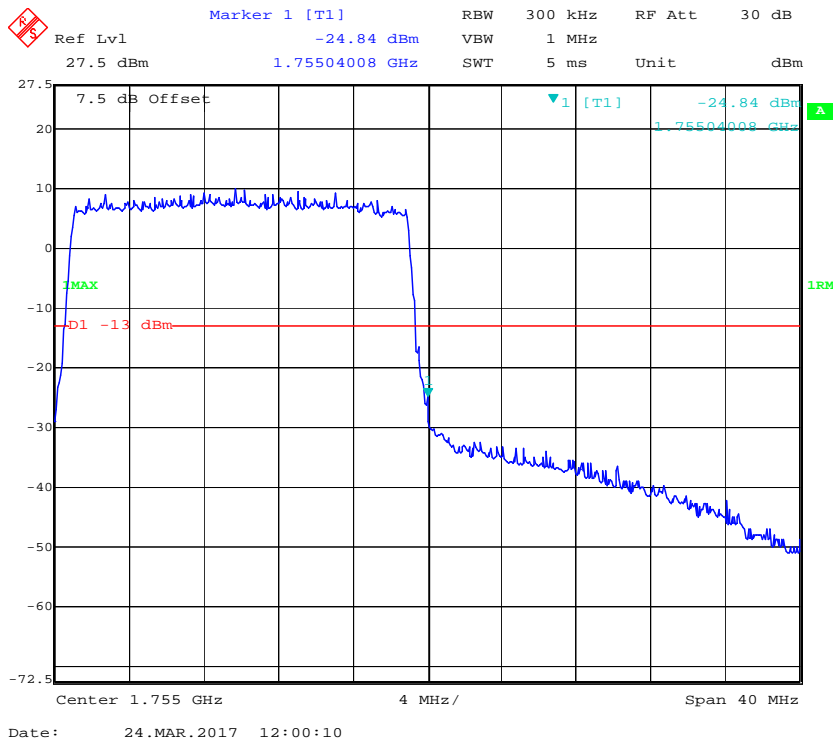

### 16-QAM (20.0 MHz, FULL RB) - Left Band Edge

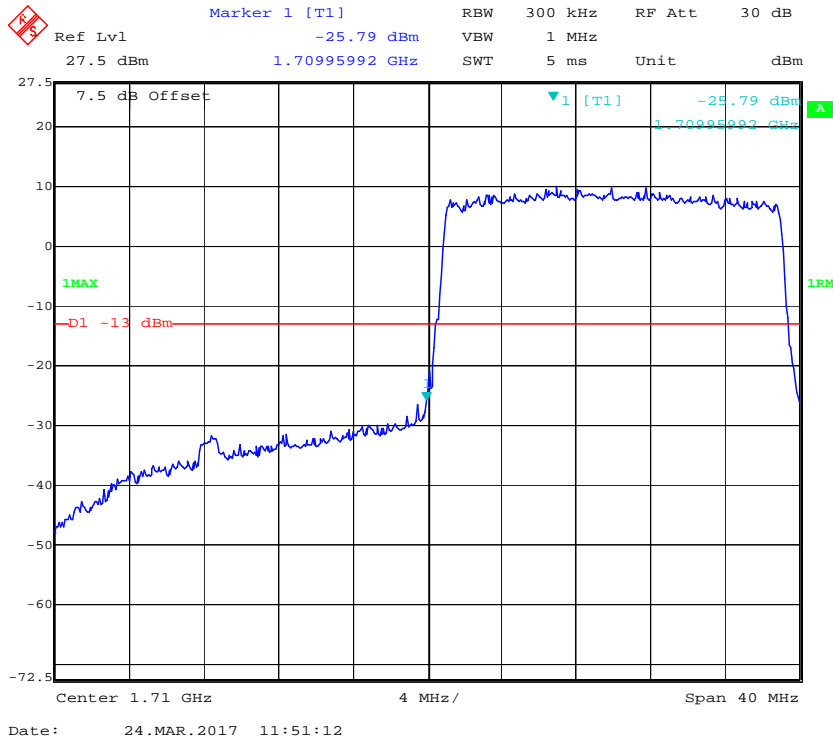

### 16-QAM (20.0 MHz, FULL RB) - Right Band Edge

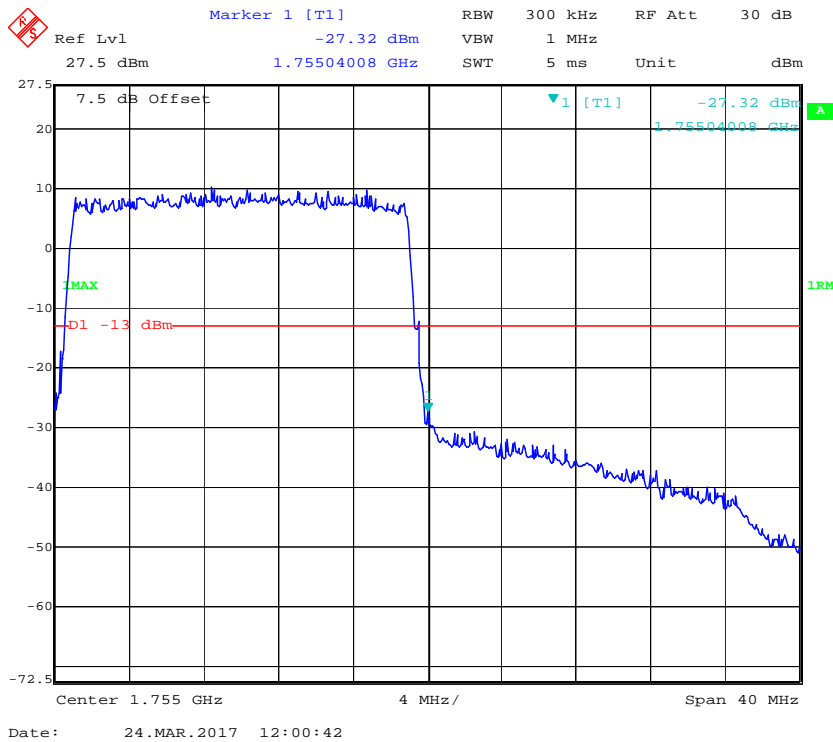

LTE Band 5:

QPSK (1.4 MHz, FULL RB) - Left Band Edge

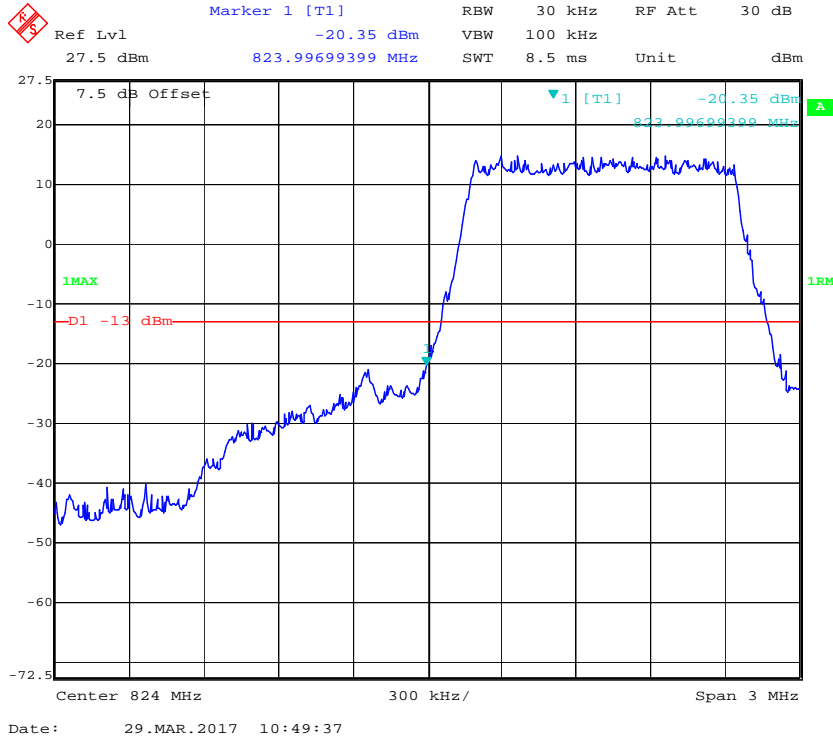

QPSK (1.4 MHz, FULL RB) - Right Band Edge

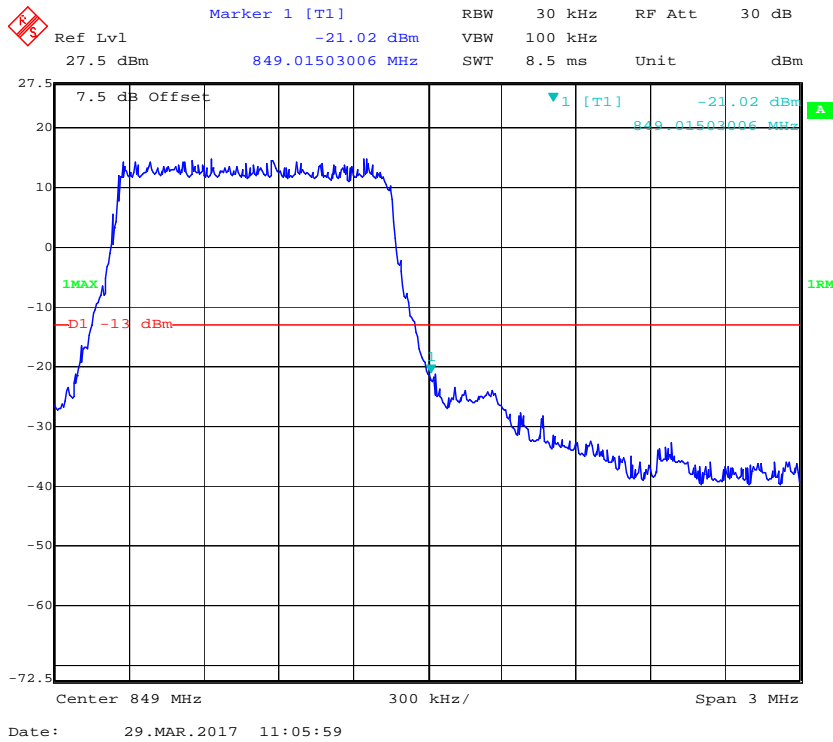

### 16-QAM (1.4 MHz, FULL RB) - Left Band Edge

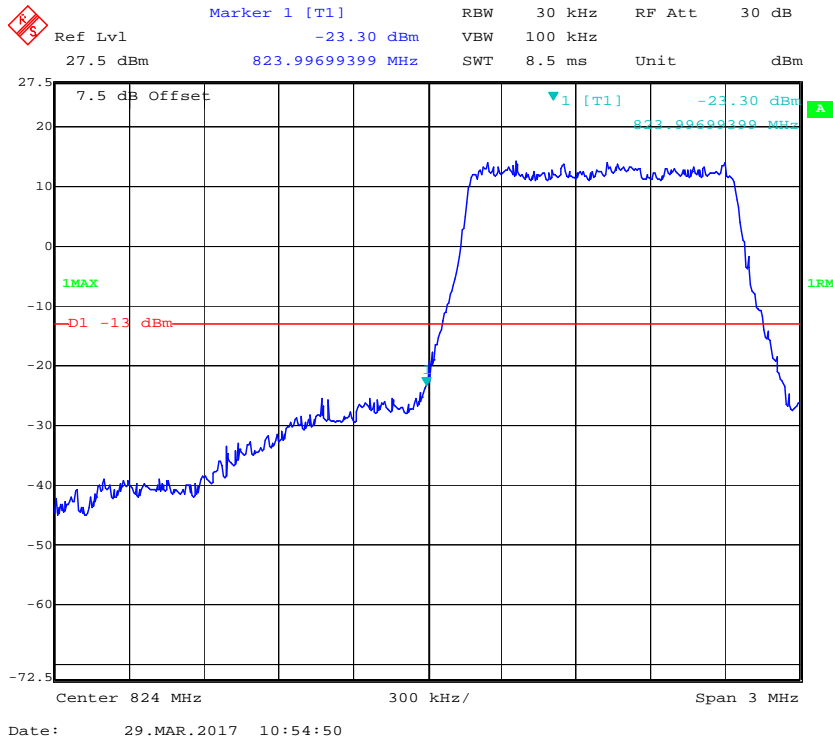

### 16-QAM (1.4 MHz, FULL RB) - Right Band Edge

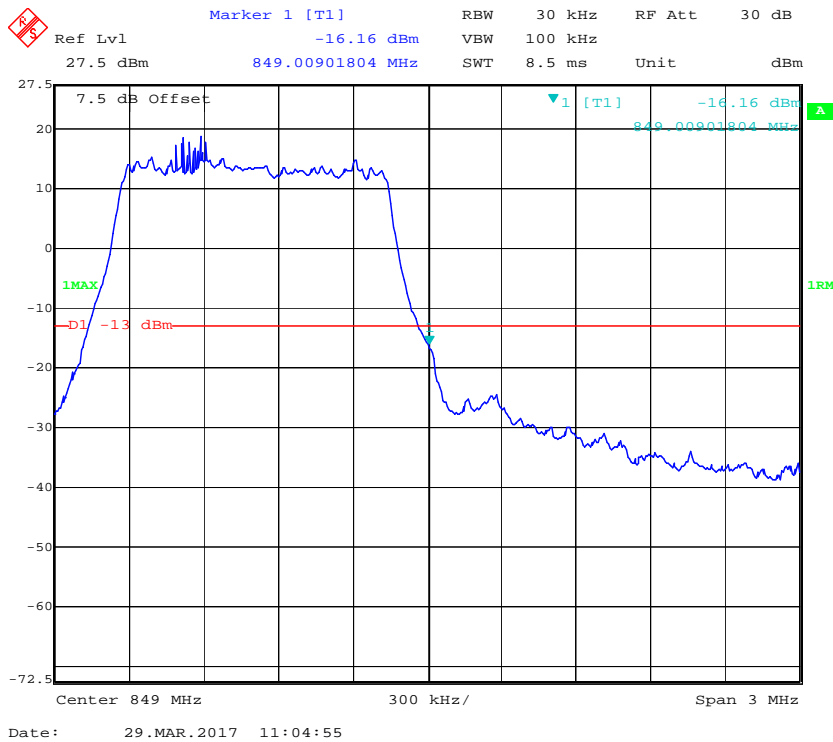

### QPSK (3.0 MHz, FULL RB) - Left Band Edge

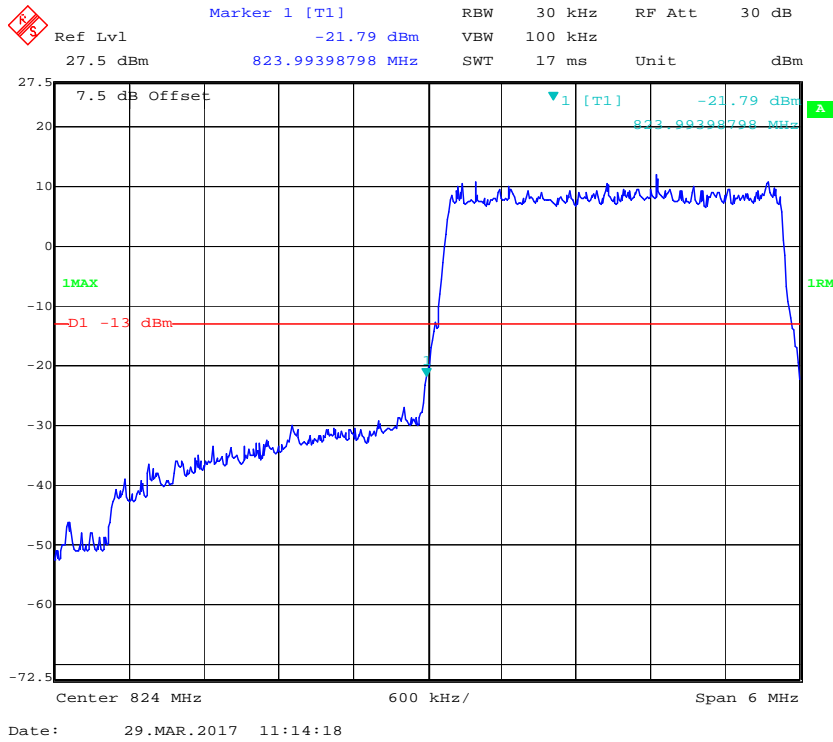

### QPSK (3.0 MHz, FULL RB) - Right Band Edge

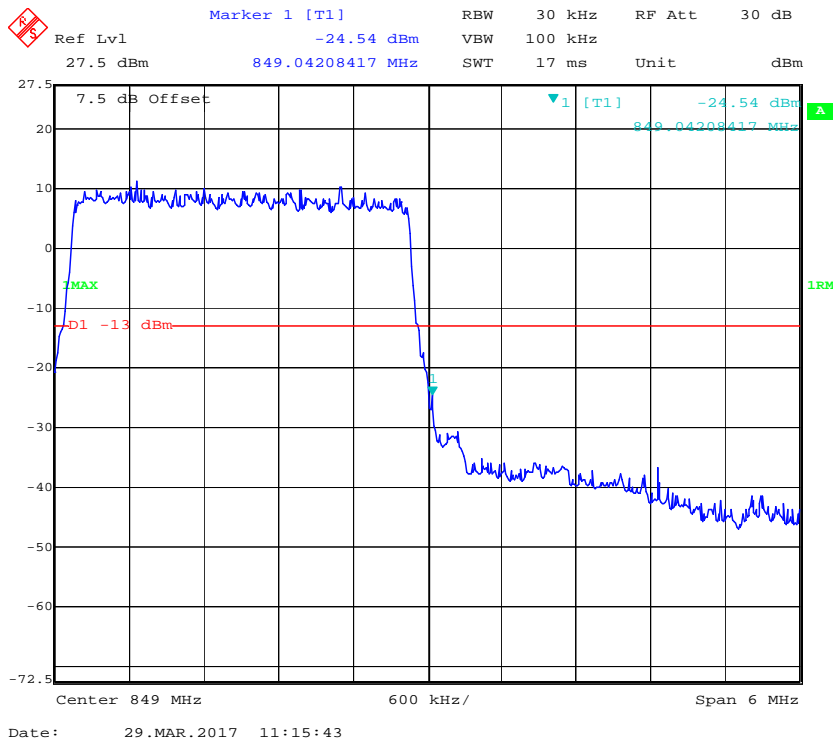

### 16-QAM (3.0 MHz, FULL RB) - Left Band Edge

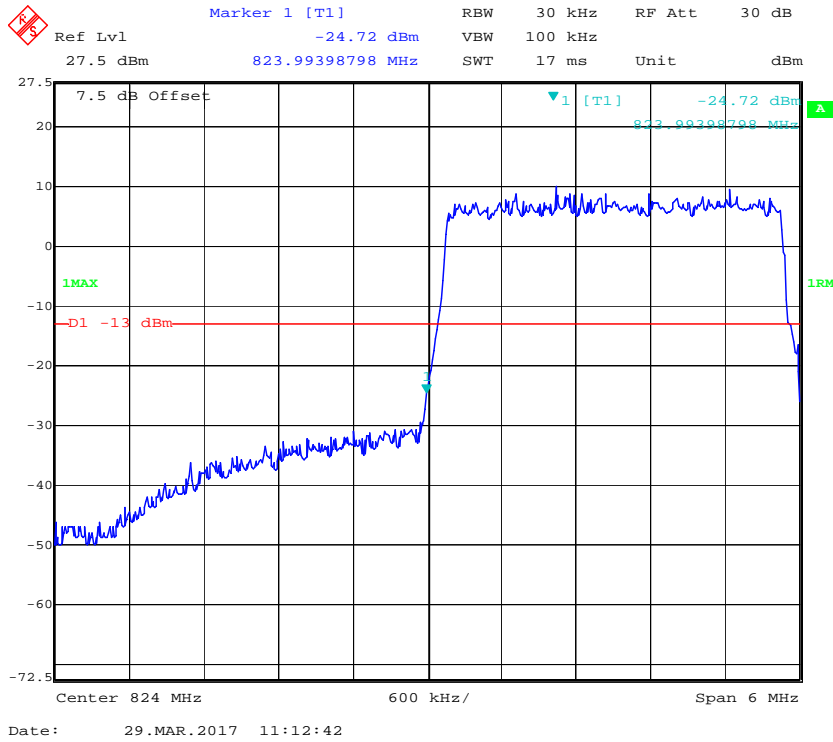

### 16-QAM (3.0 MHz, FULL RB) - Right Band Edge

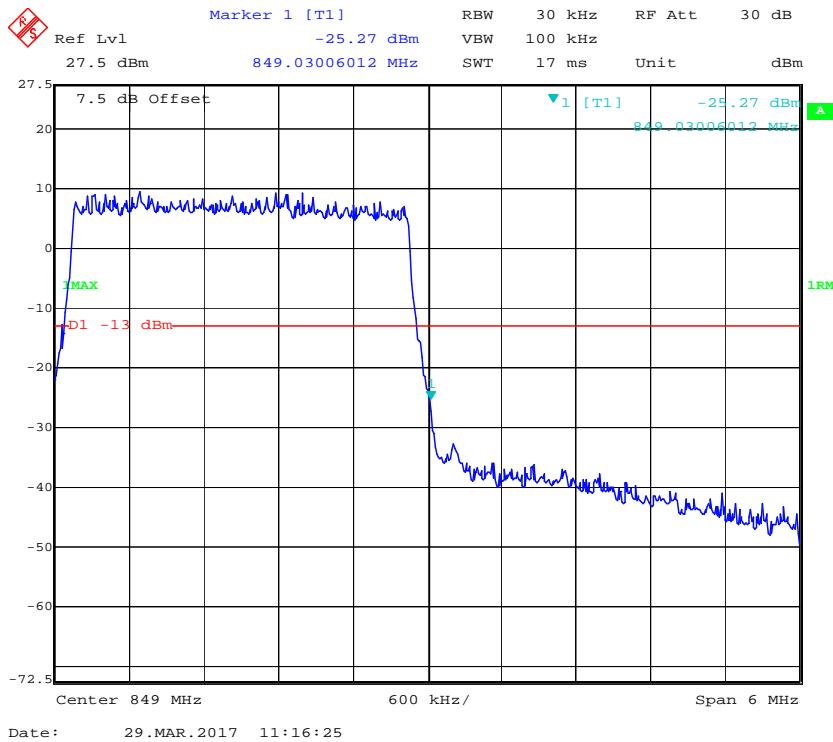

### QPSK (5.0 MHz, FULL RB) - Left Band Edge

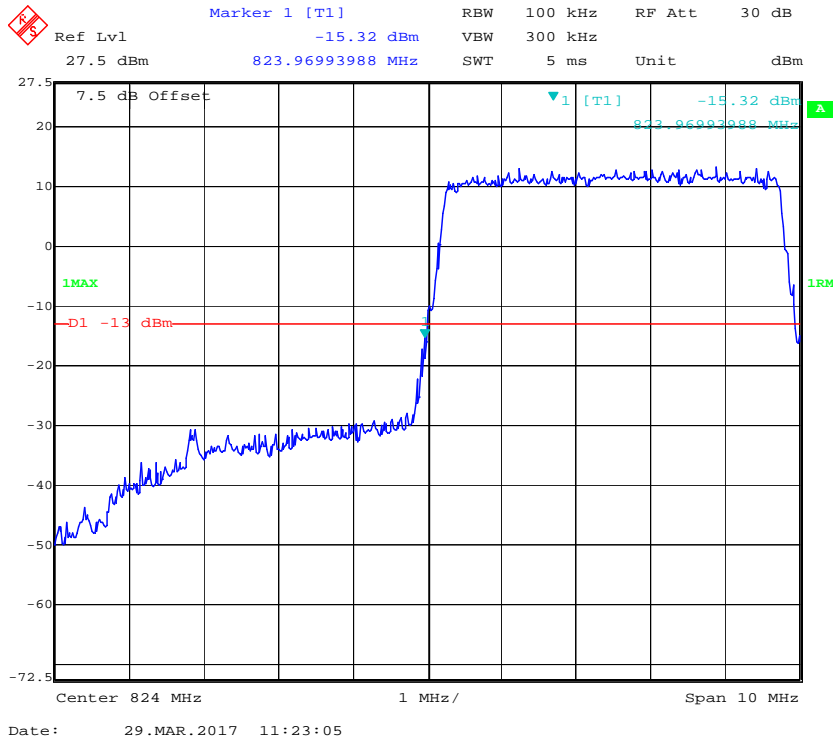

### QPSK (5.0 MHz, FULL RB) - Right Band Edge

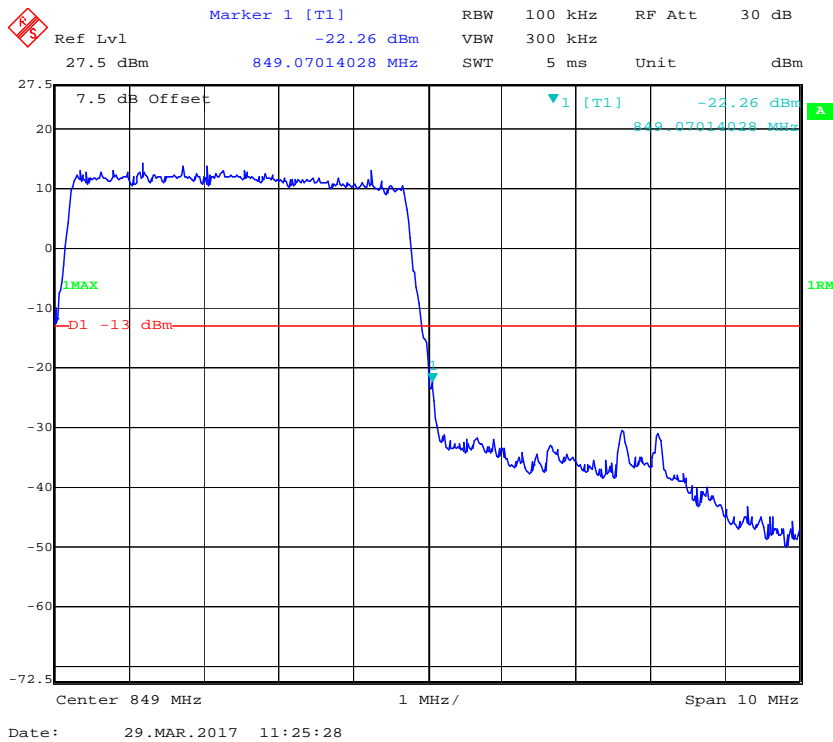



### 16-QAM (5.0 MHz, FULL RB) - Left Band Edge

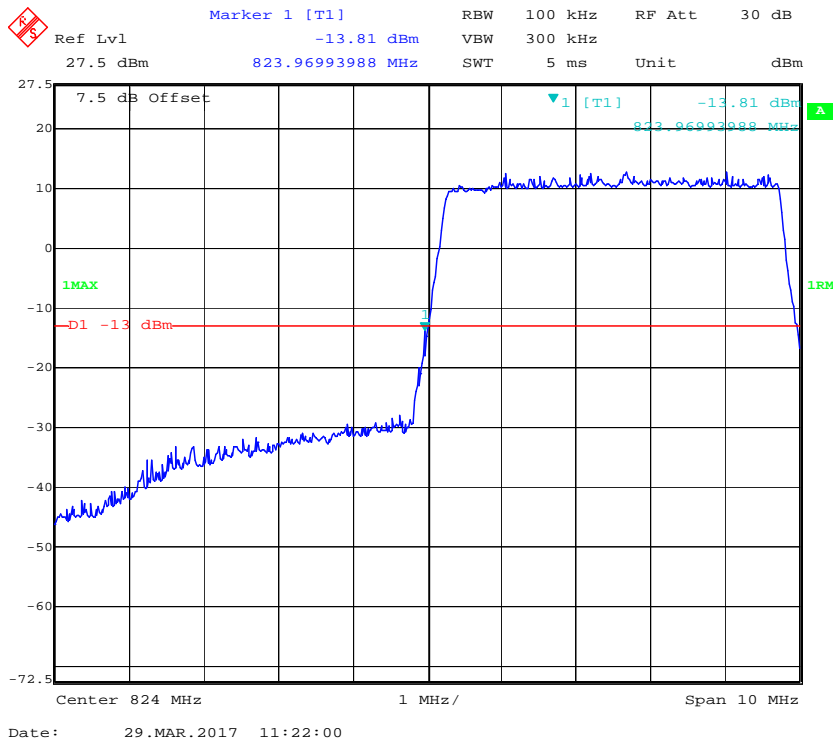

### 16-QAM (5.0 MHz, FULL RB) - Right Band Edge

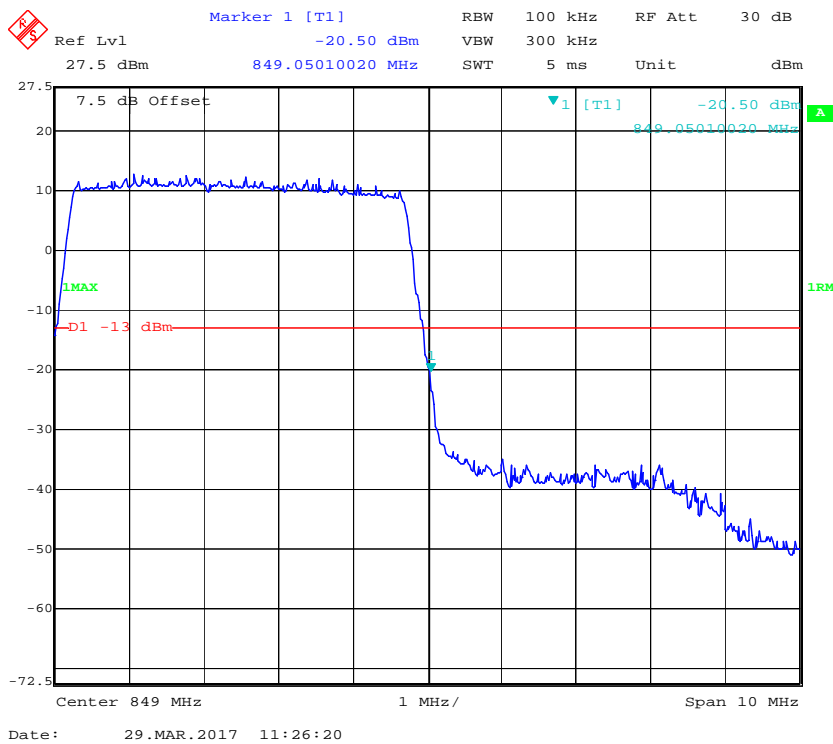

**QPSK (10.0 MHz, FULL RB) - Left Band Edge**

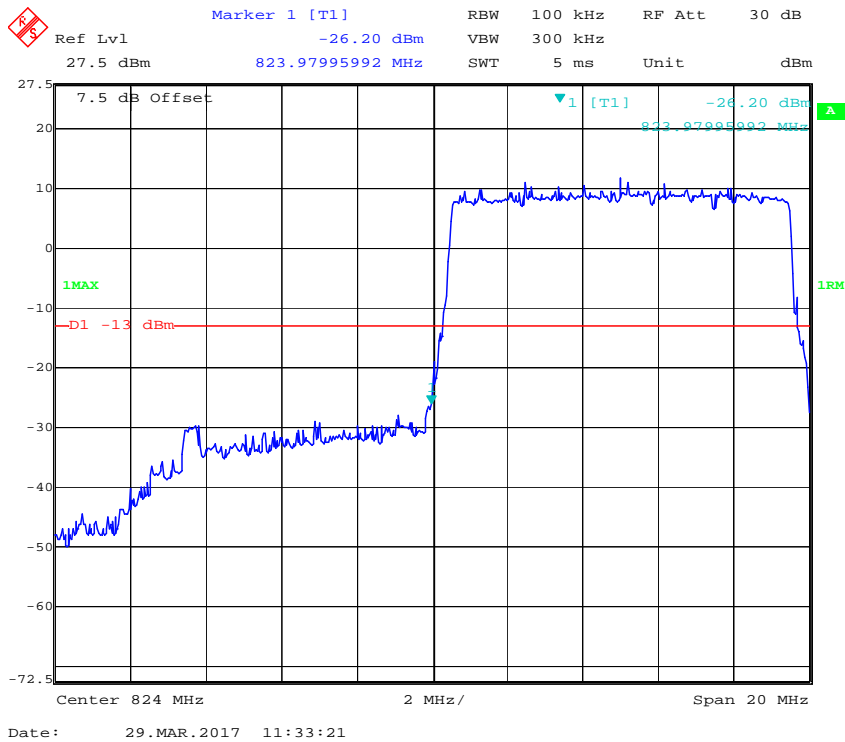

**QPSK (10.0 MHz, FULL RB) - Right Band Edge**

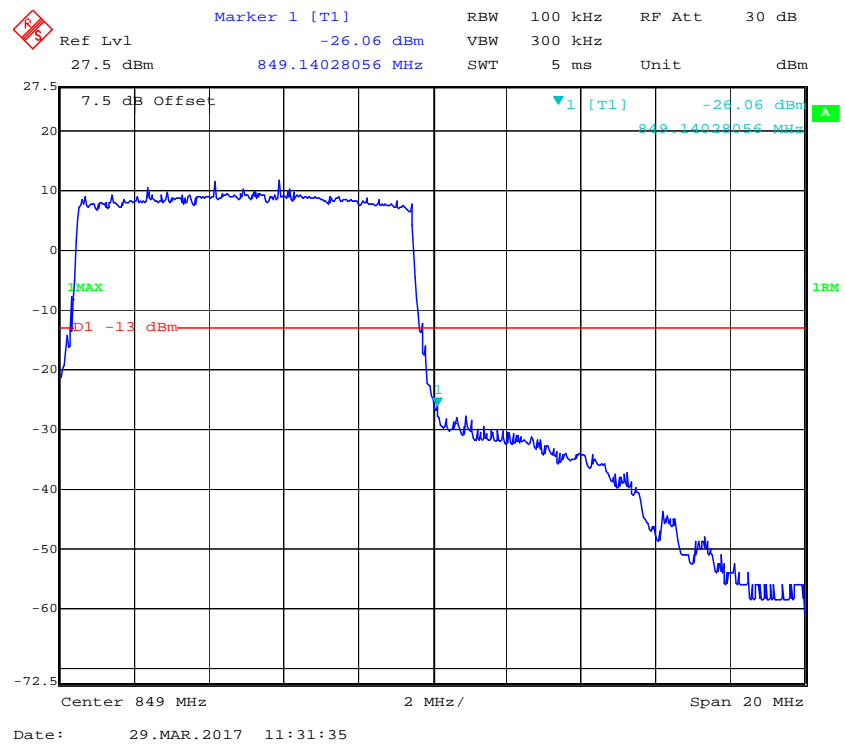

**16-QAM (10.0 MHz, FULL RB) - Left Band Edge**

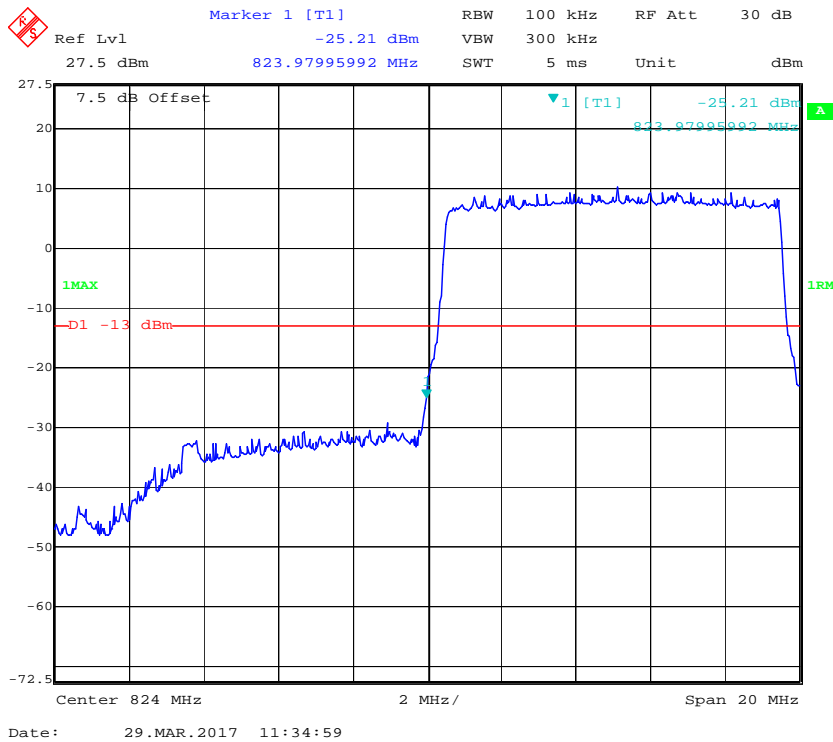

**16-QAM (10.0 MHz, FULL RB) - Right Band Edge**

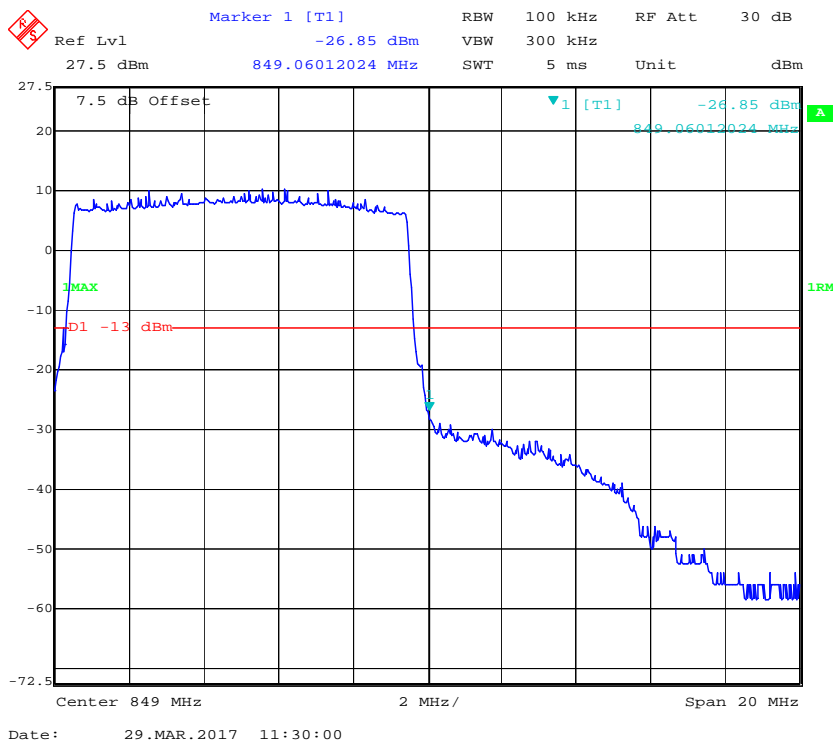

LTE Band 7:

QPSK (5.0 MHz, FULL RB) - Left Band Edge

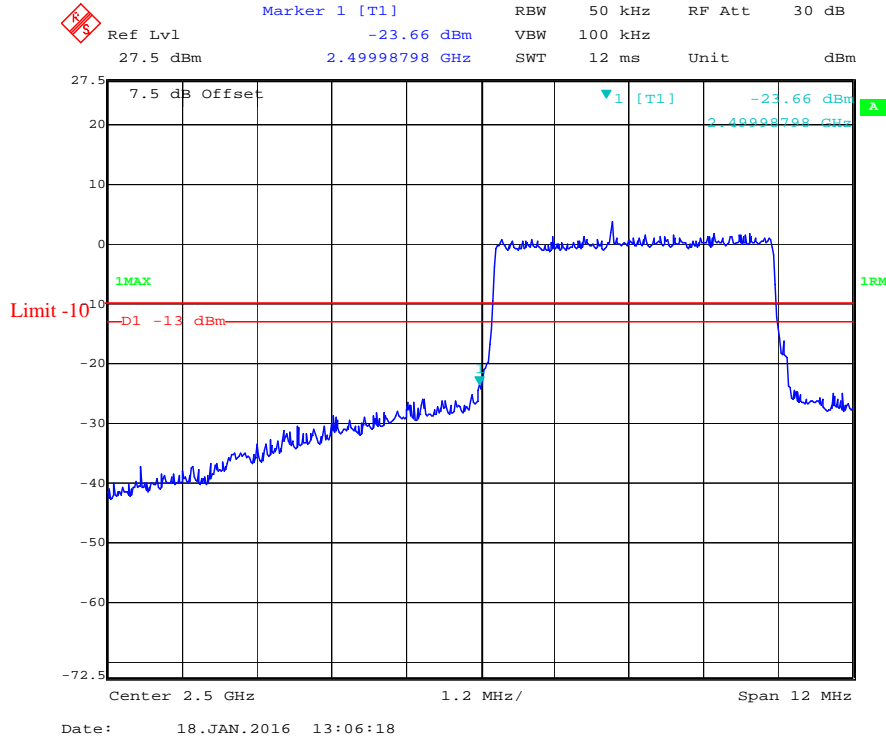

QPSK (5.0 MHz, FULL RB) - Right Band Edge

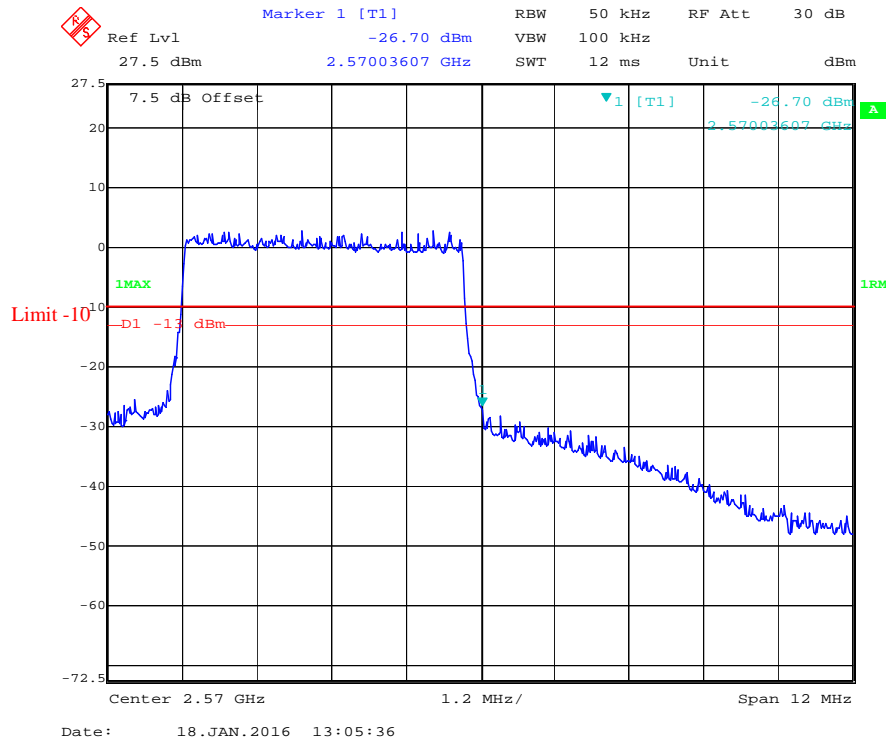

### 16-QAM (5.0 MHz, FULL RB) - Left Band Edge

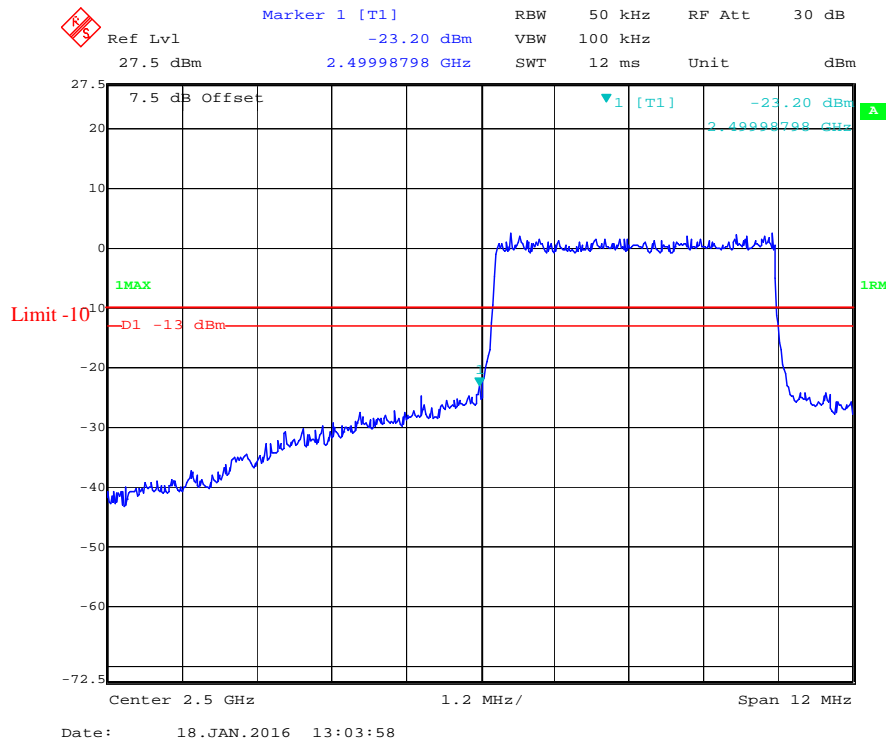

### 16-QAM (5.0 MHz, FULL RB) - Right Band Edge

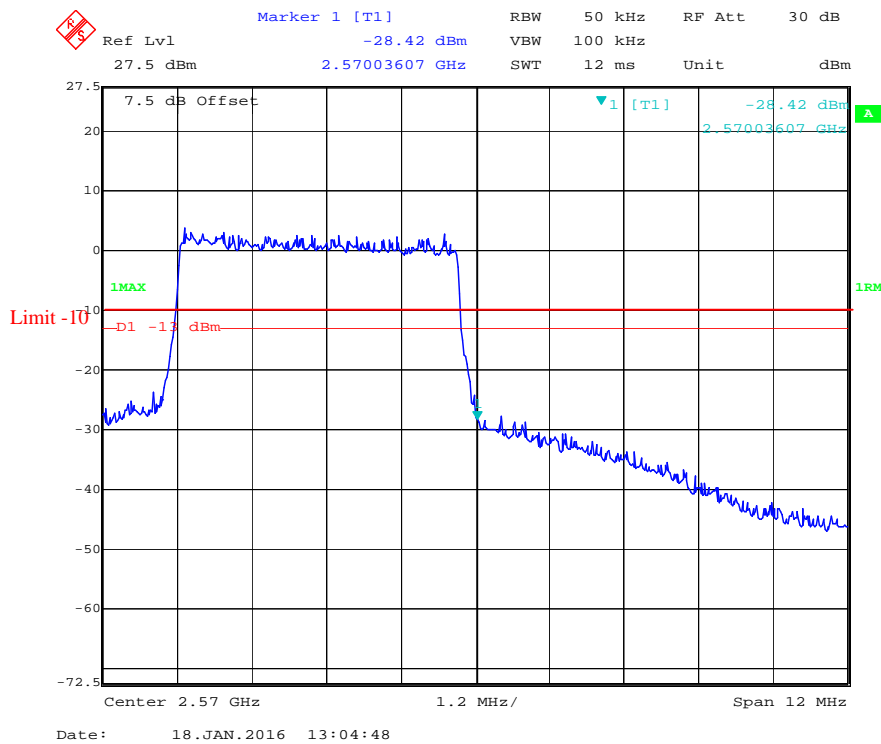

**QPSK (10.0 MHz, FULL RB) - Left Band Edge**

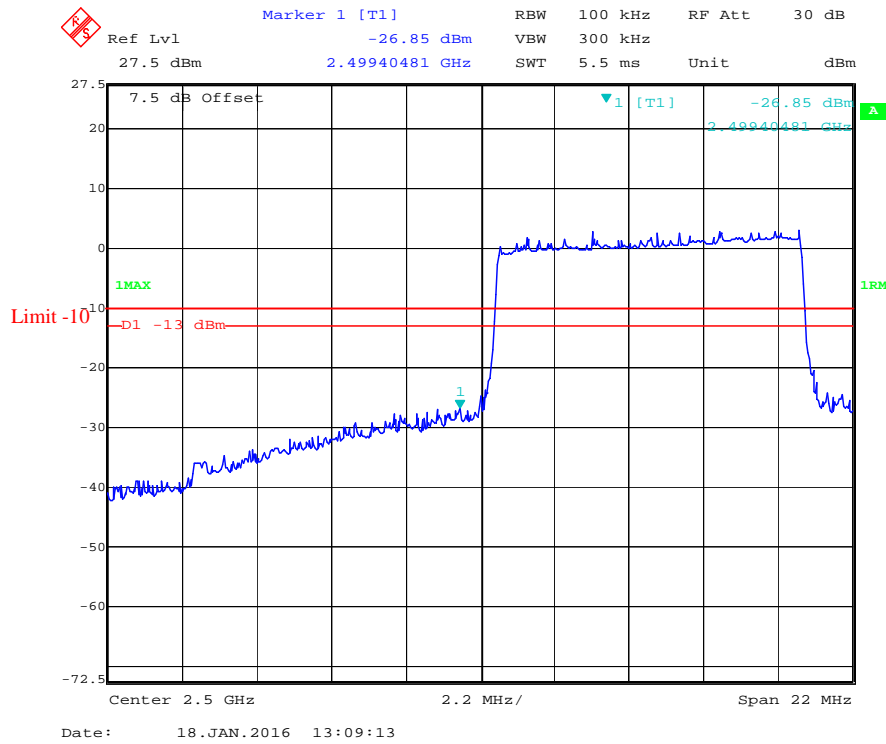

**QPSK (10.0 MHz, FULL RB) - Right Band Edge**

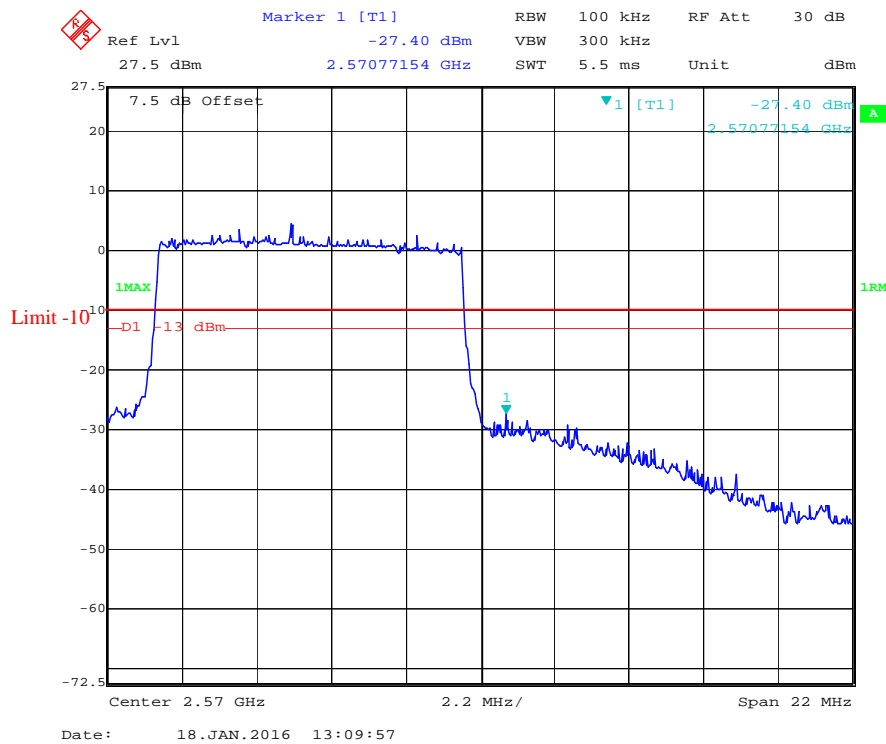

### 16-QAM (10.0 MHz, FULL RB) - Left Band Edge

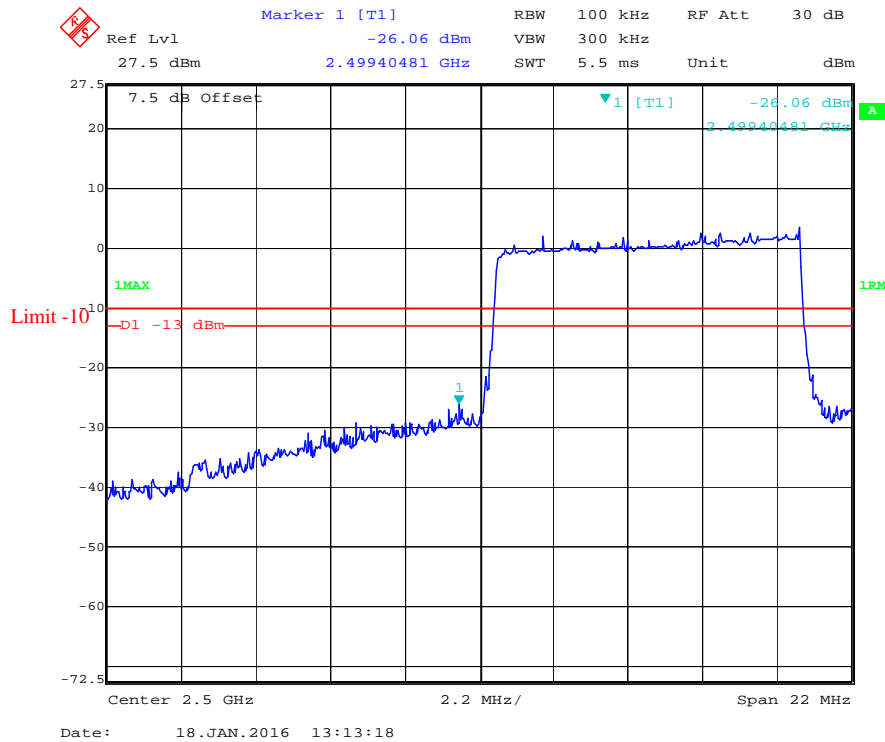

### 16-QAM (10.0 MHz, FULL RB) - Right Band Edge

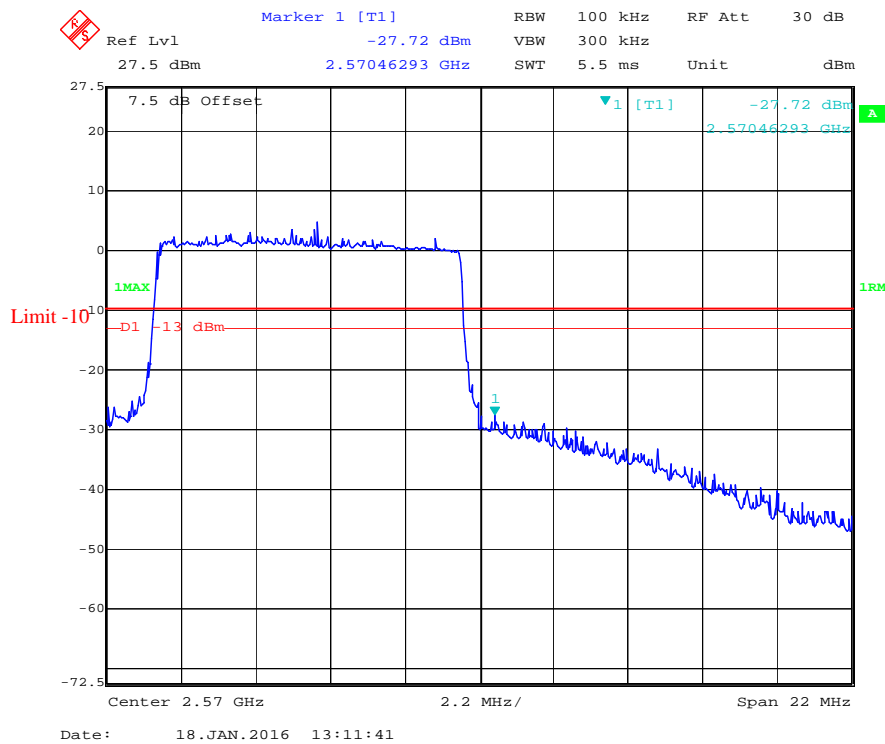

### QPSK (15 MHz, FULL RB) - Left Band Edge

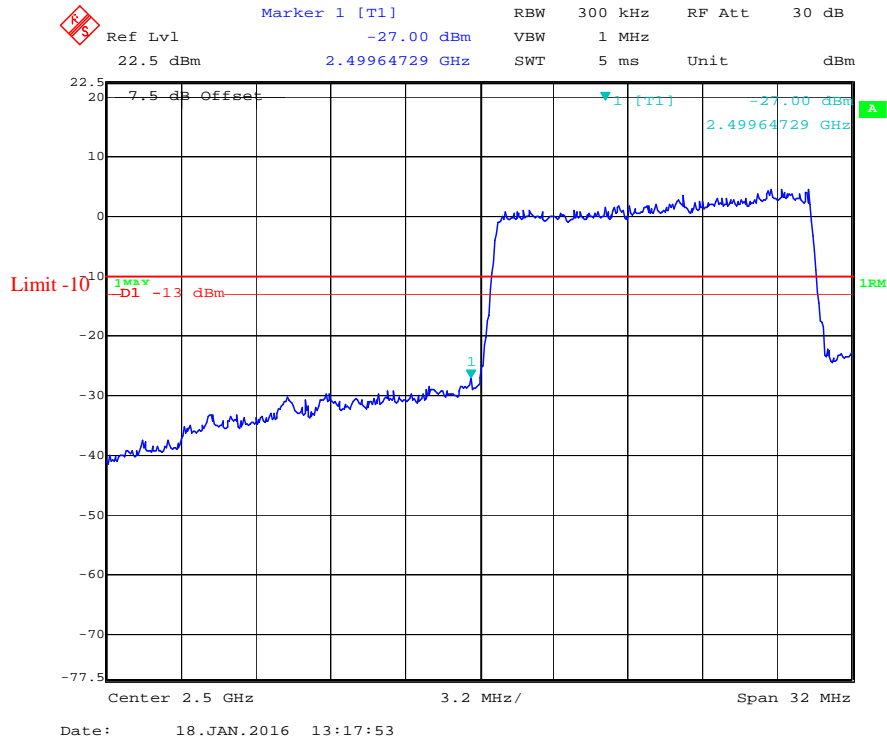

### QPSK (15 MHz, FULL RB) - Right Band Edge

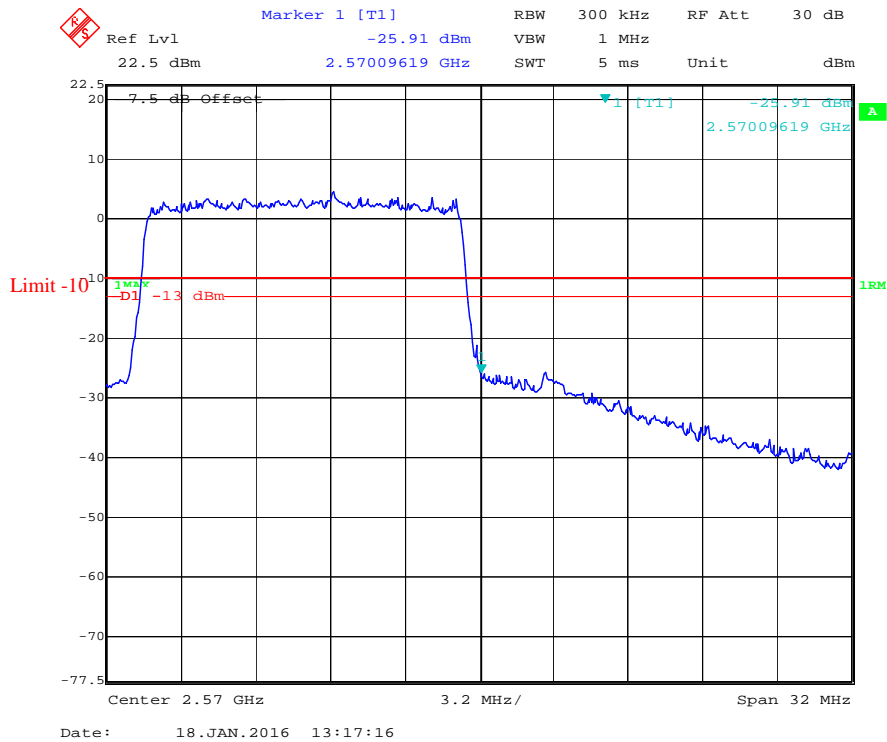



### 16-QAM (15 MHz, FULL RB) - Left Band Edge

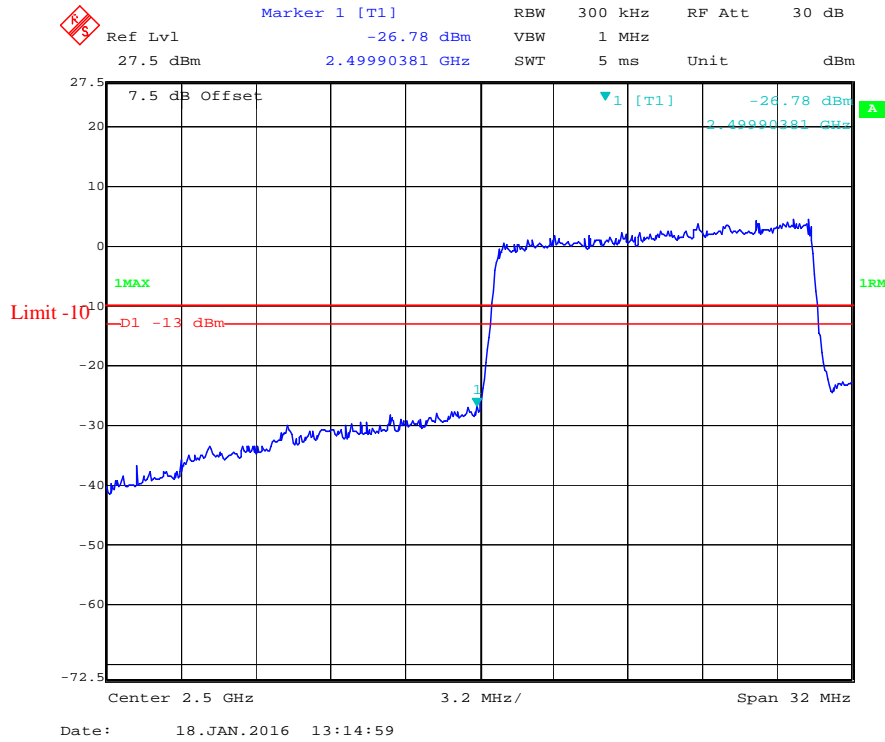

### 16-QAM (15 MHz, FULL RB) - Right Band Edge

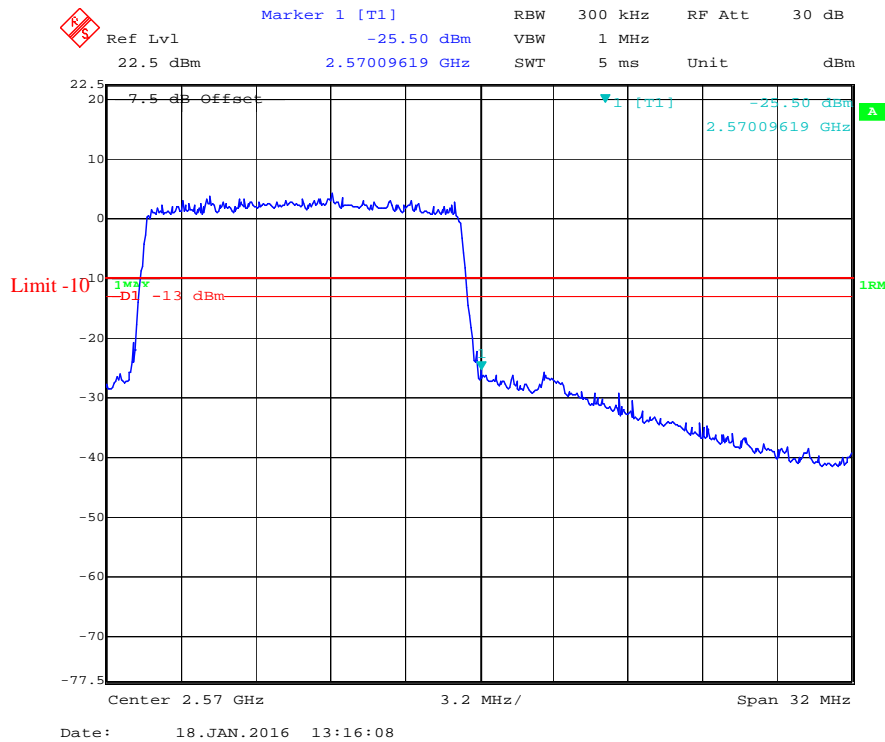

### QPSK (20 MHz, FULL RB) - Left Band Edge

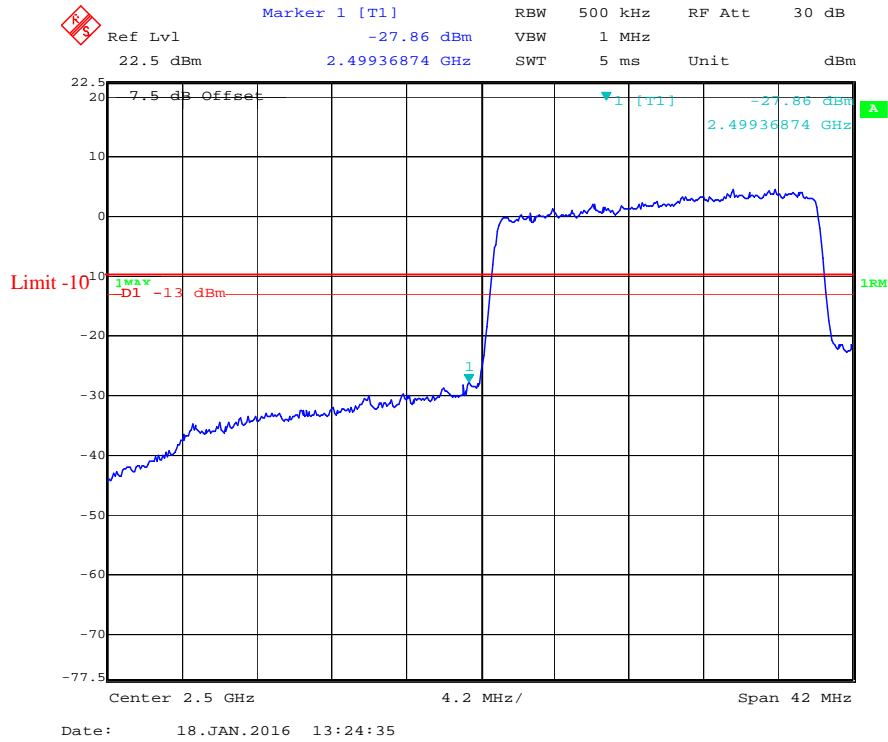

### QPSK (20 MHz, FULL RB) - Right Band Edge

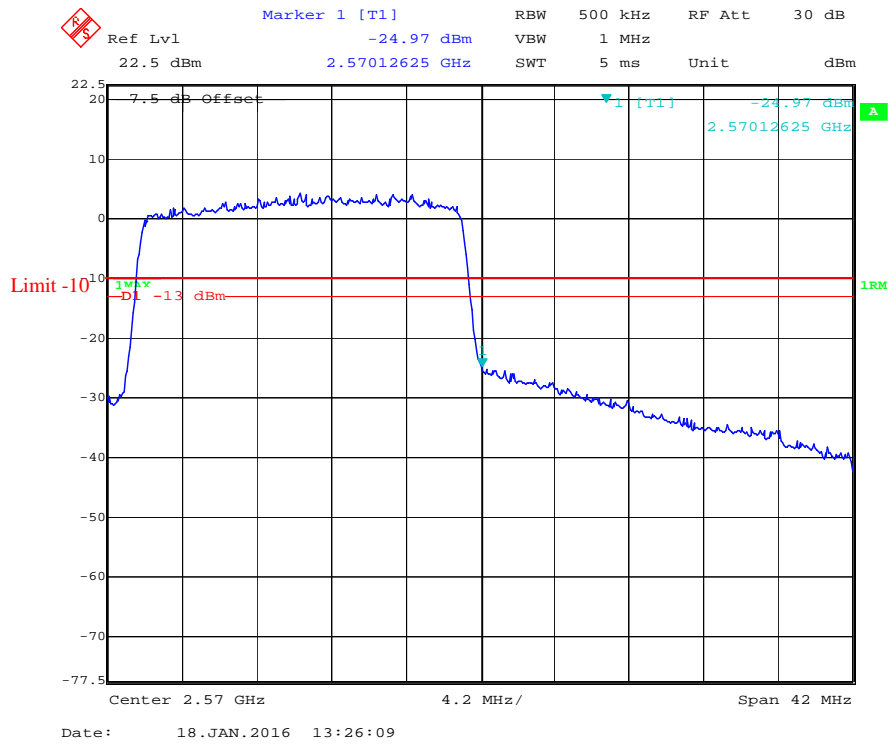

### 16-QAM (20 MHz, FULL RB) - Left Band Edge

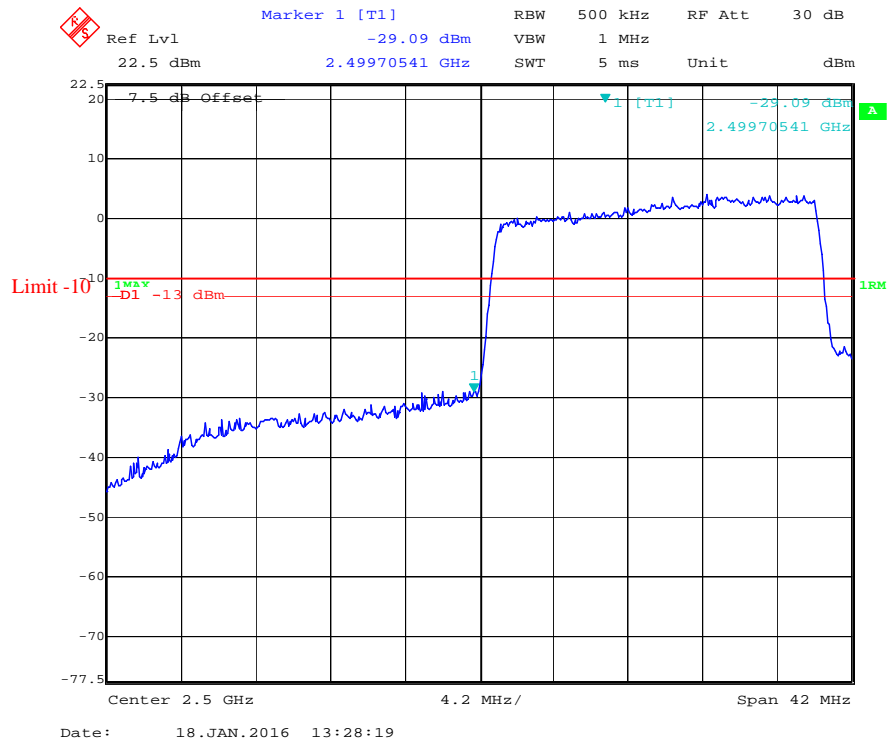

### 16-QAM (20 MHz, FULL RB) - Right Band Edge

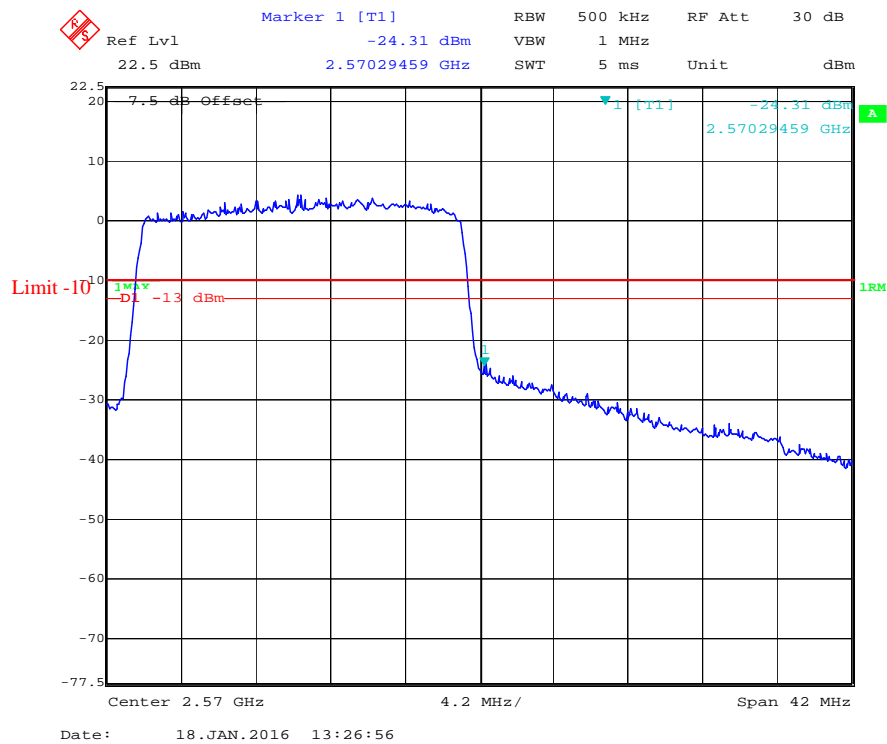

LTE Band 26:

QPSK (1.4 MHz, FULL RB) - Left Band Edge

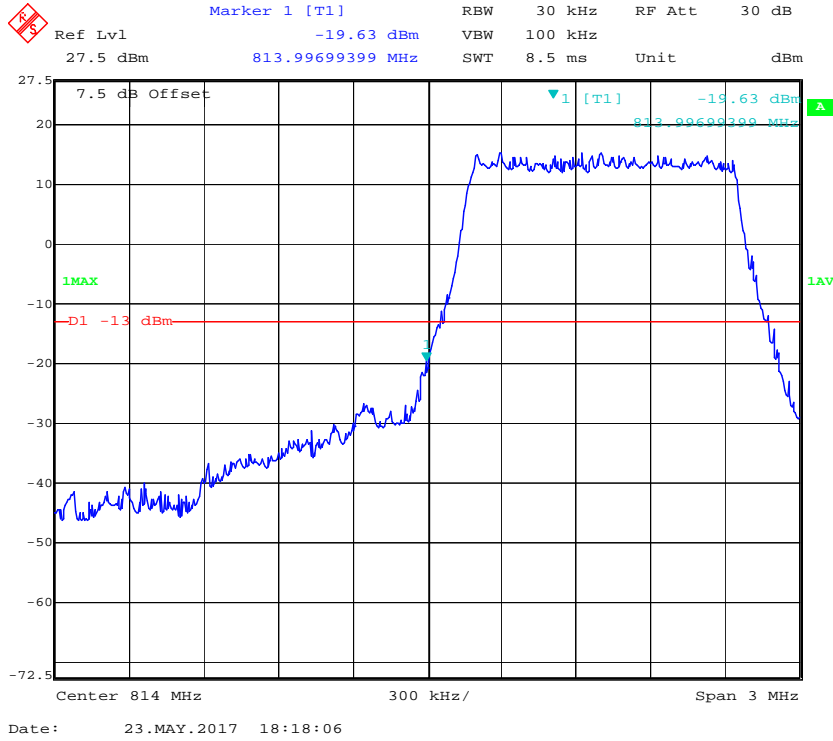

QPSK (1.4 MHz, FULL RB) - Right Band Edge



### 16-QAM (1.4 MHz, FULL RB) - Left Band Edge

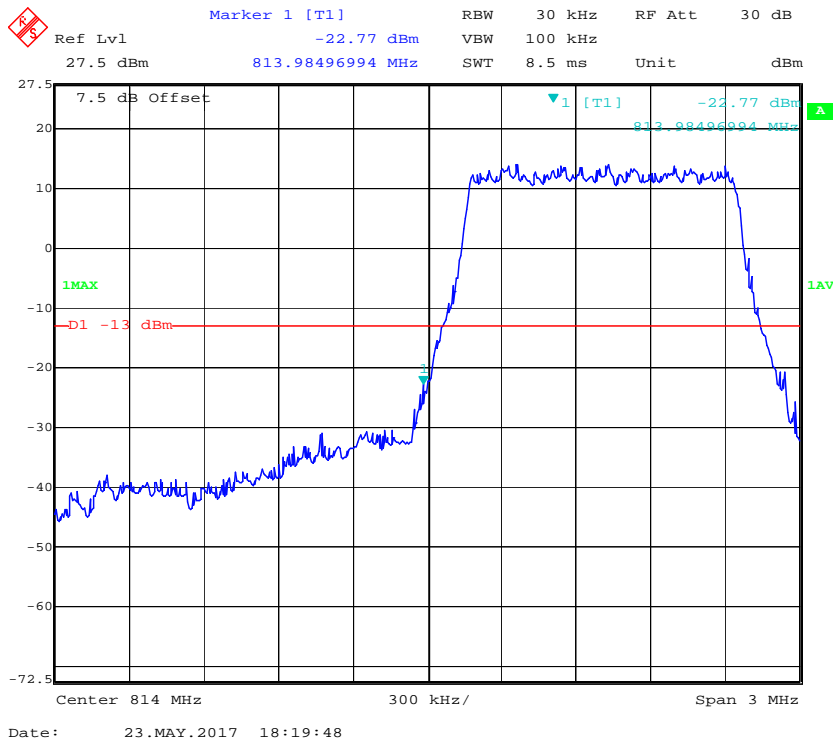

### 16-QAM (1.4 MHz, FULL RB) - Right Band Edge



### QPSK (3.0 MHz, FULL RB) - Left Band Edge

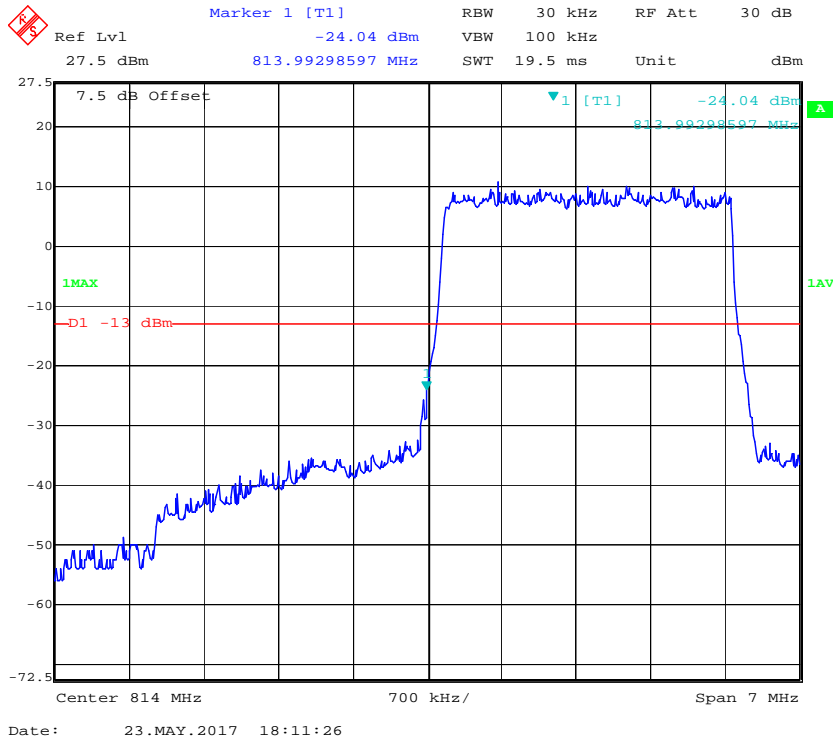

### QPSK (3.0 MHz, FULL RB) - Right Band Edge

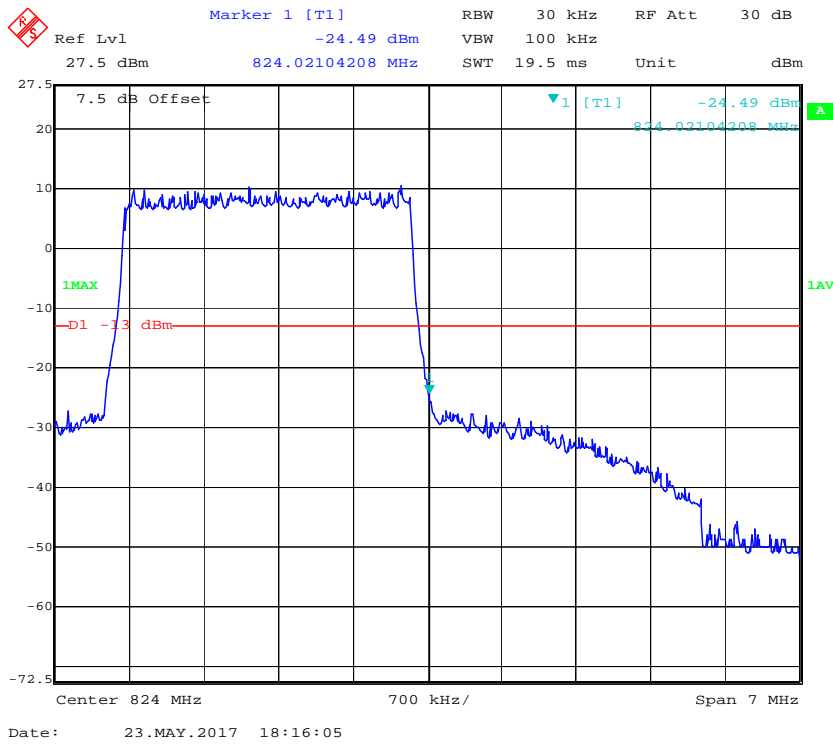

### 16-QAM (3.0 MHz, FULL RB) - Left Band Edge

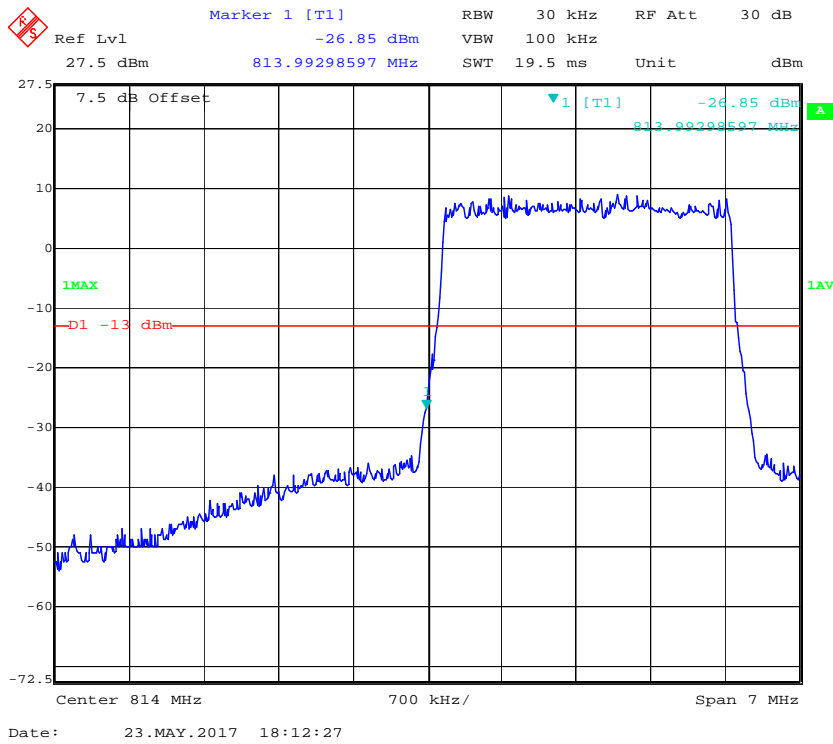

### 16-QAM (3.0 MHz, FULL RB) - Right Band Edge

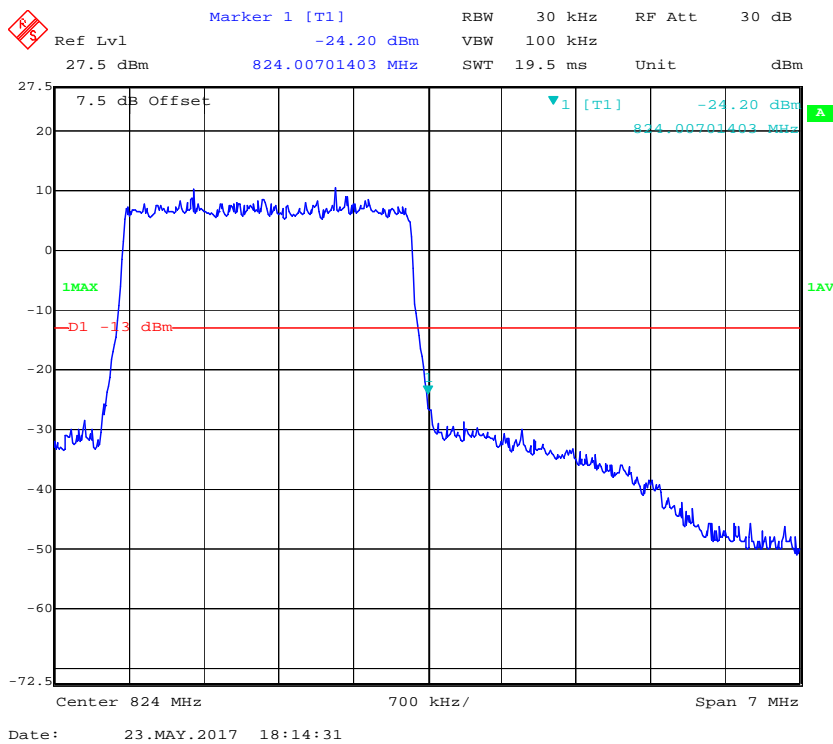

### QPSK (5.0 MHz, FULL RB) - Left Band Edge

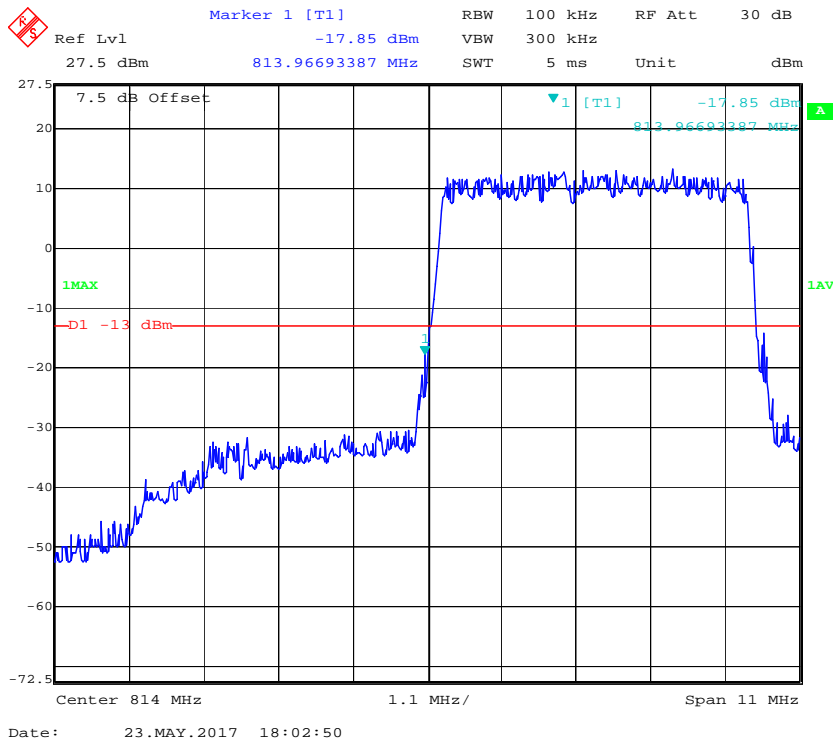

### QPSK (5.0 MHz, FULL RB) - Right Band Edge

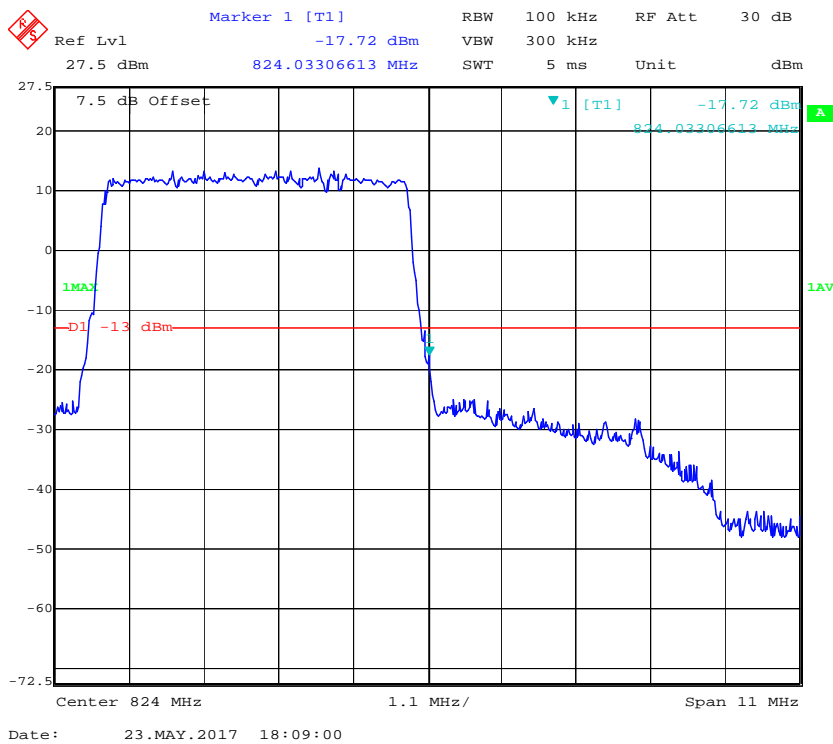



### 16-QAM (5.0 MHz, FULL RB) - Left Band Edge

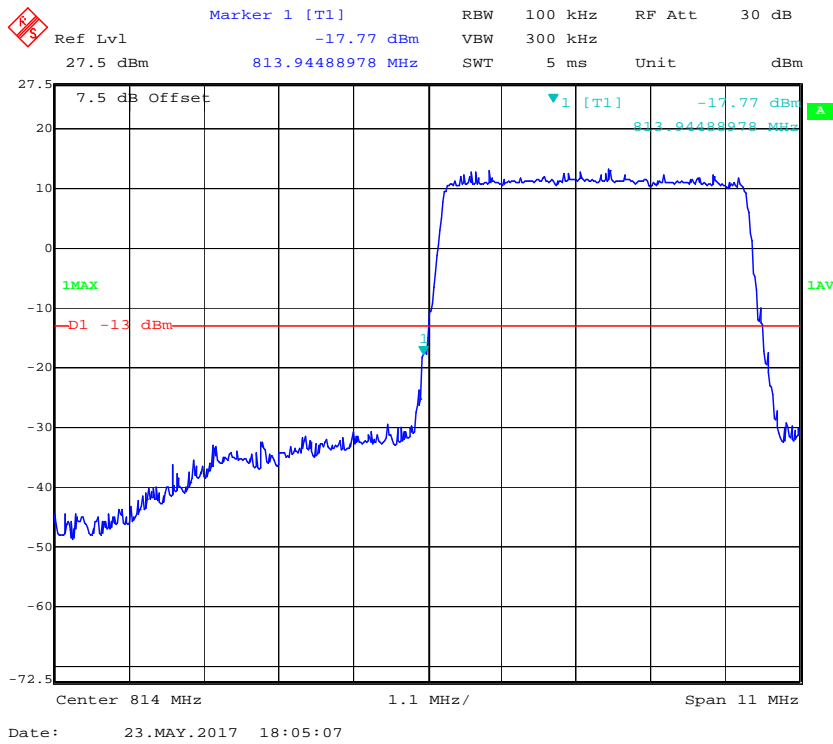

### 16-QAM (5.0 MHz, FULL RB) - Right Band Edge

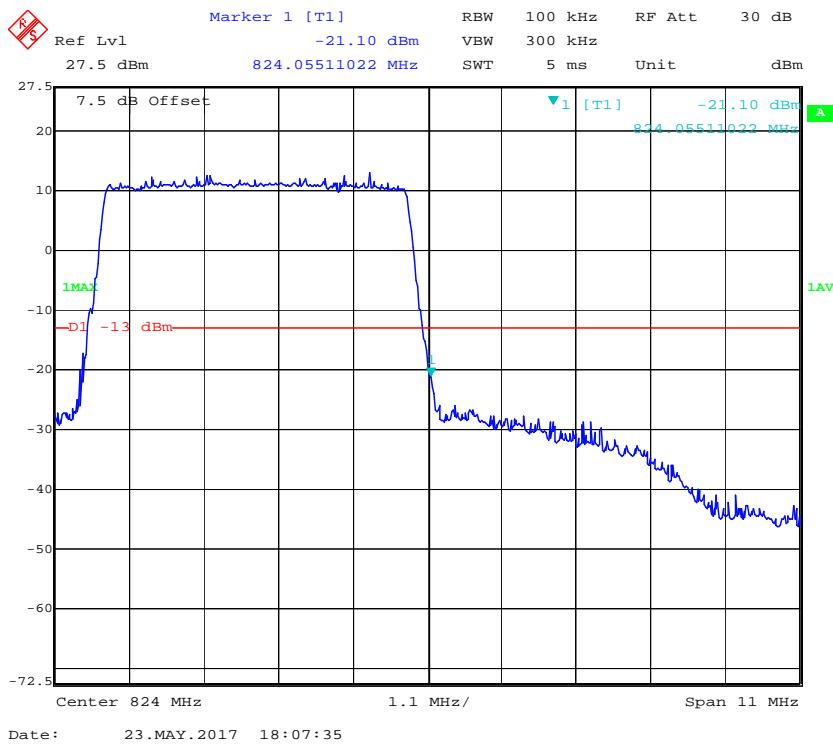

### QPSK (10.0 MHz, FULL RB) - Left Band Edge

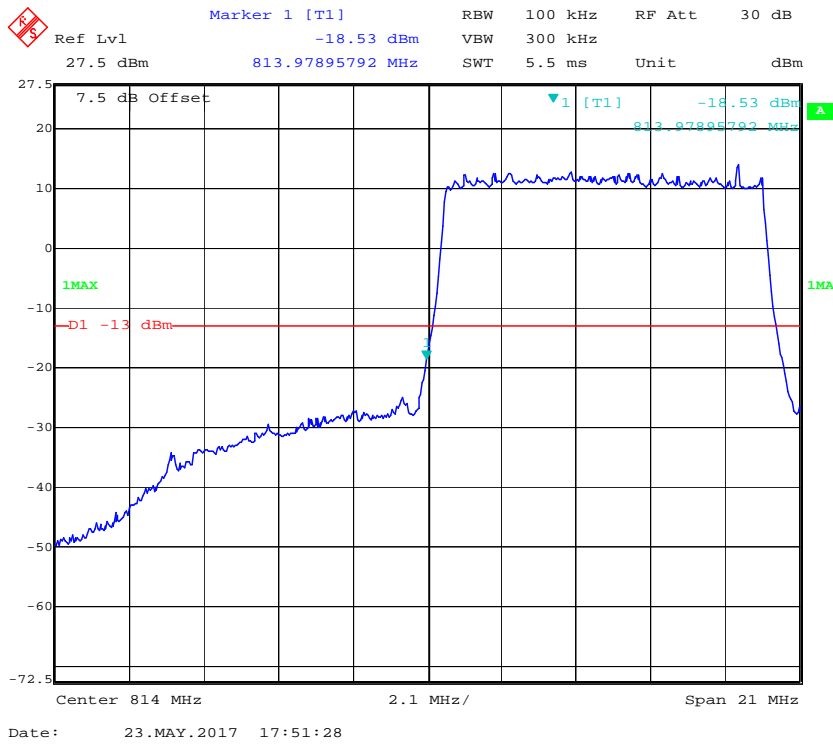

### QPSK (10.0 MHz, FULL RB) - Right Band Edge

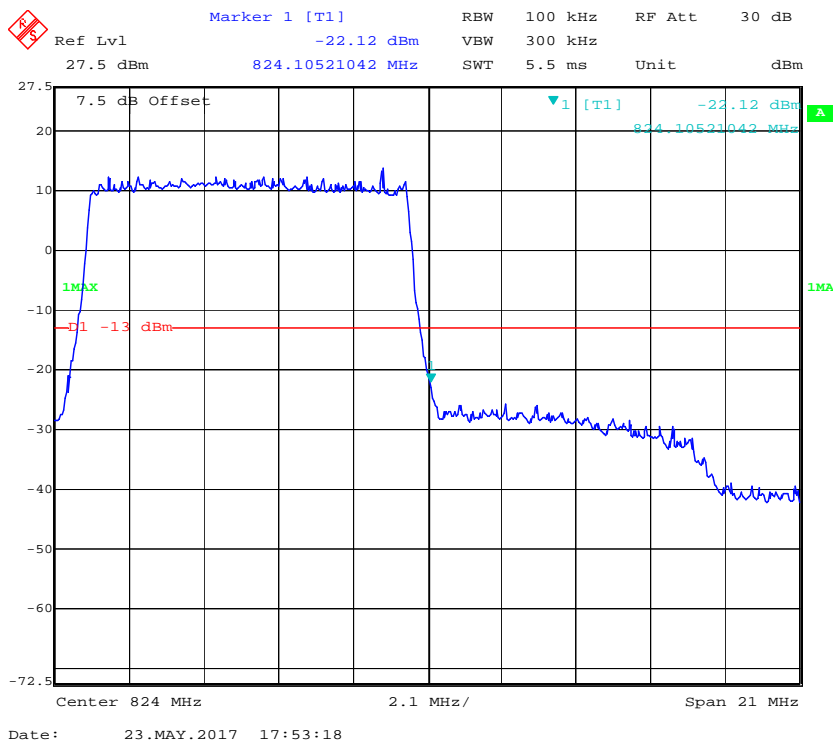

**16-QAM (10.0 MHz, FULL RB) - Left Band Edge**

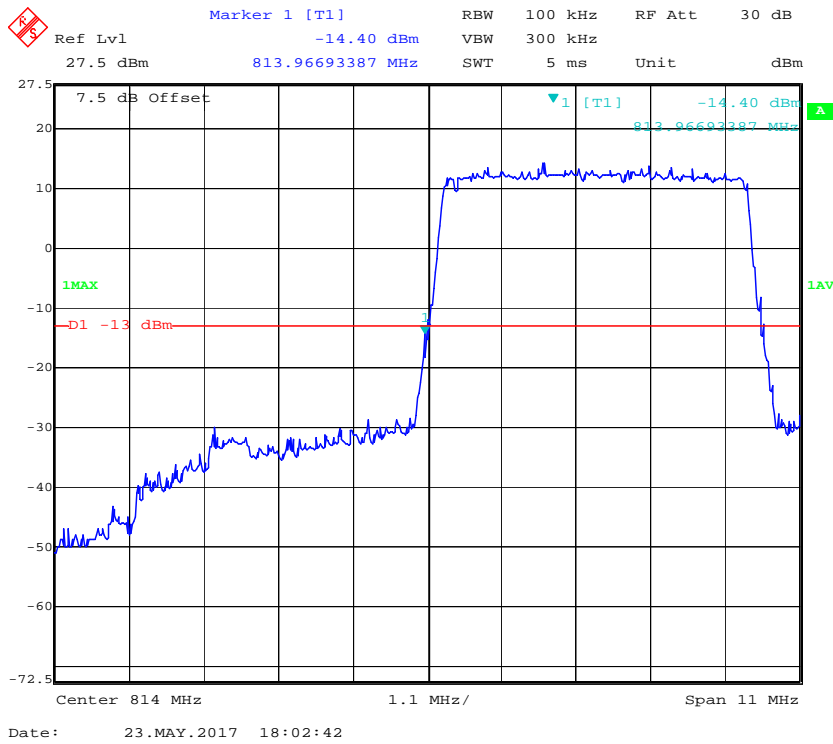

**16-QAM (10.0 MHz, FULL RB) - Right Band Edge**

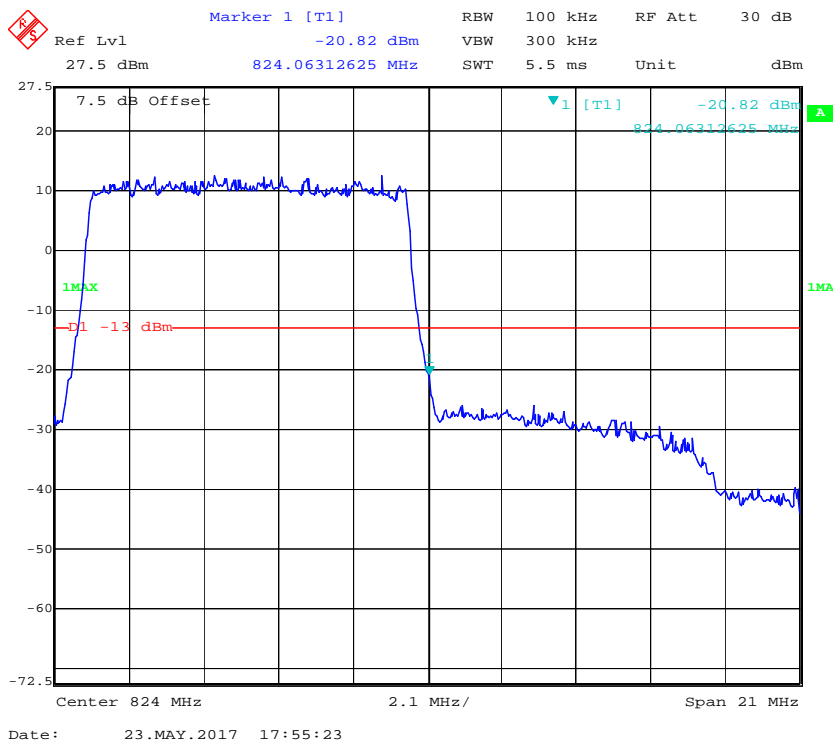

LTE Band 38:

QPSK (5.0 MHz, FULL RB) - Left Band Edge

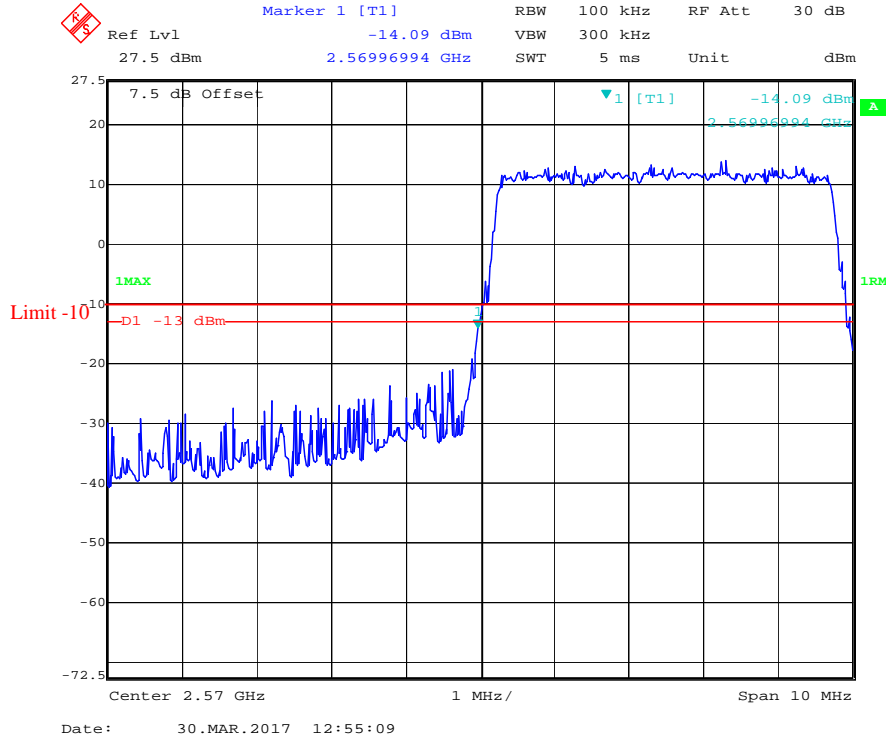

QPSK (5.0 MHz, FULL RB) - Right Band Edge

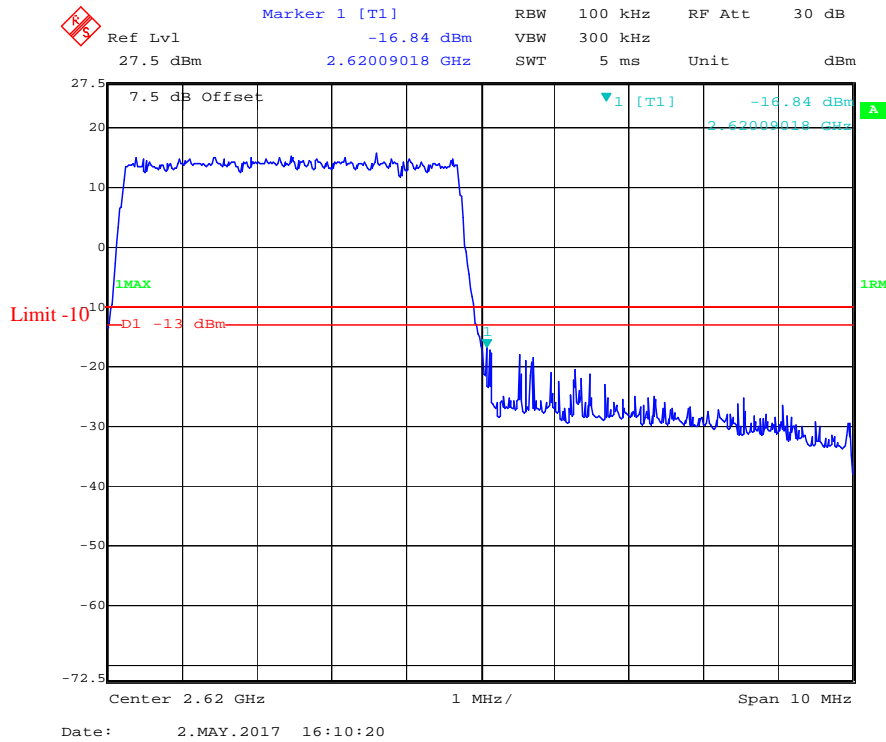

### 16-QAM (5.0 MHz, FULL RB) - Left Band Edge

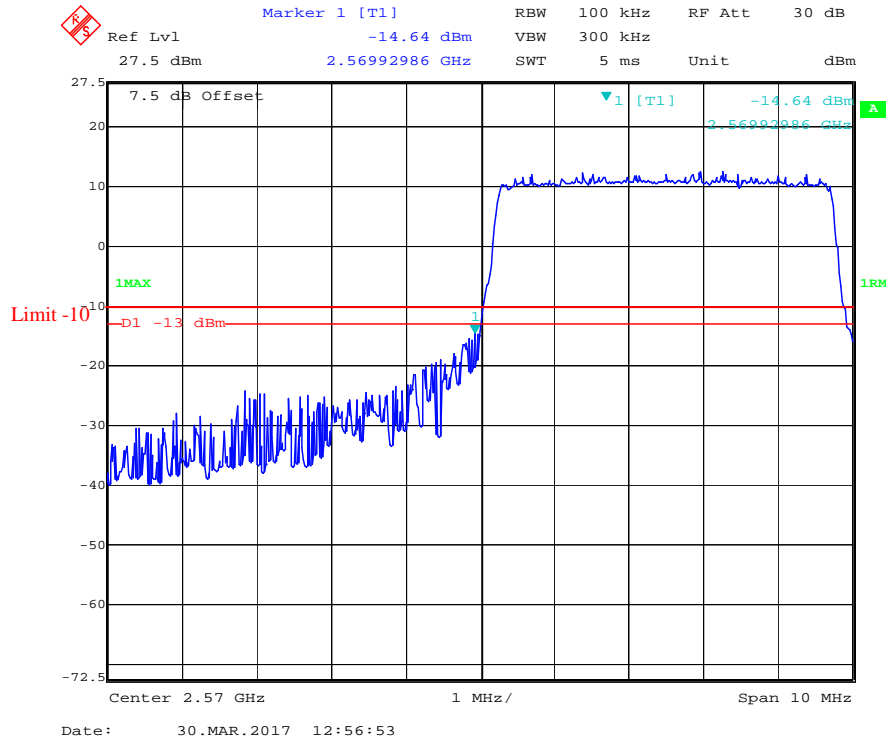

### 16-QAM (5.0 MHz, FULL RB) - Right Band Edge

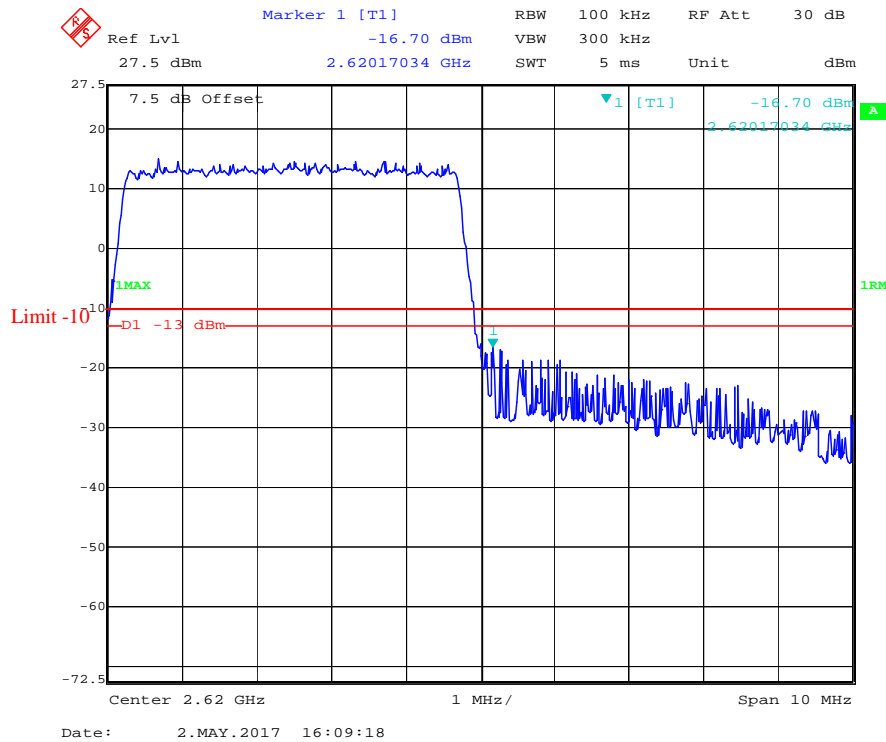

**QPSK (10.0 MHz, FULL RB) - Left Band Edge**

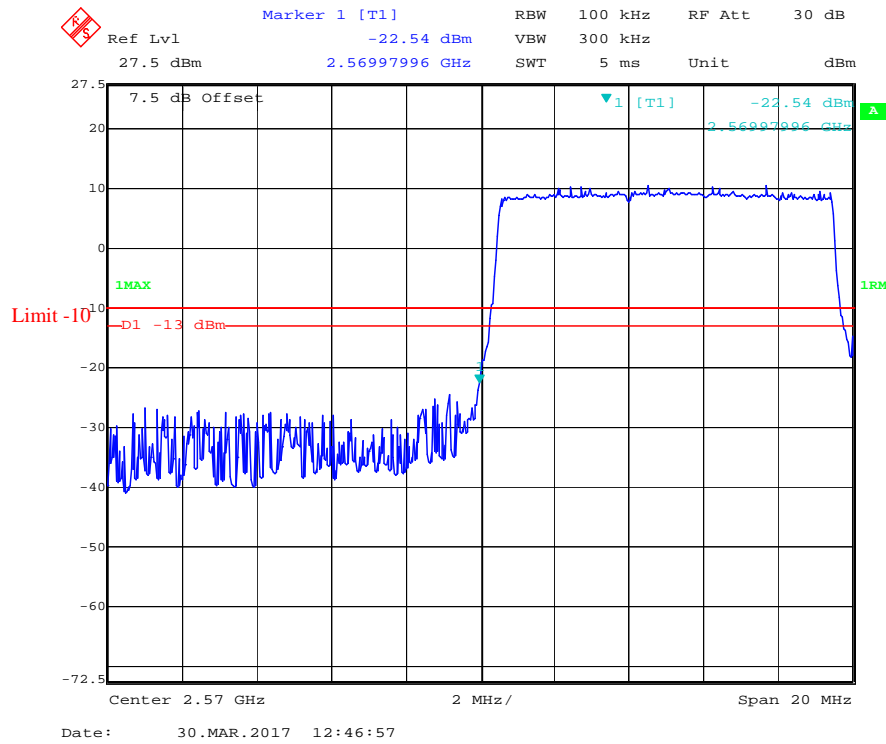

**QPSK (10.0 MHz, FULL RB) - Right Band Edge**

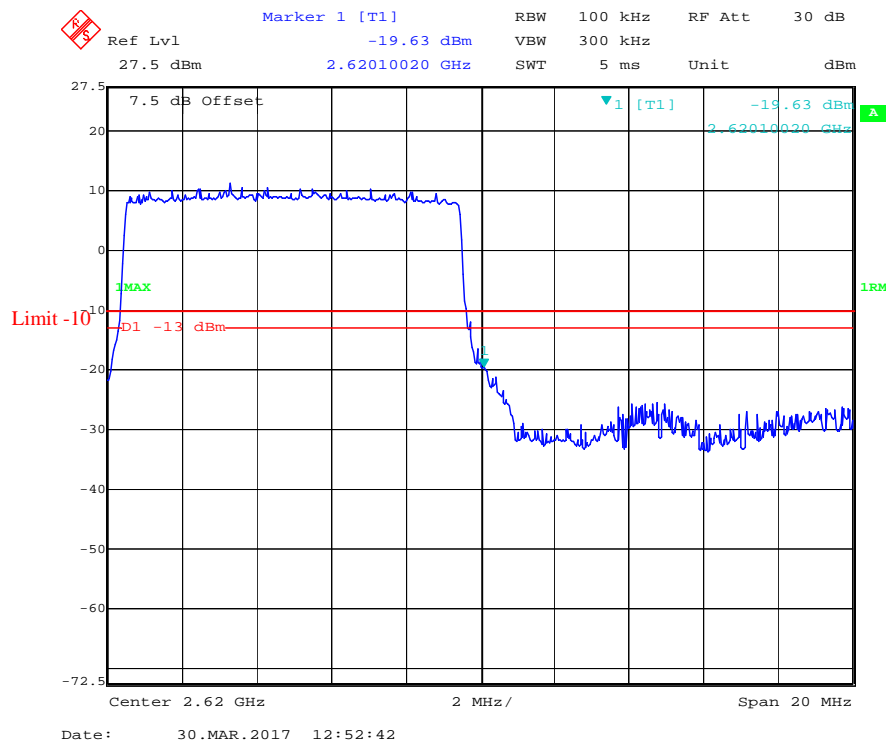

### 16-QAM (10.0 MHz, FULL RB) - Left Band Edge

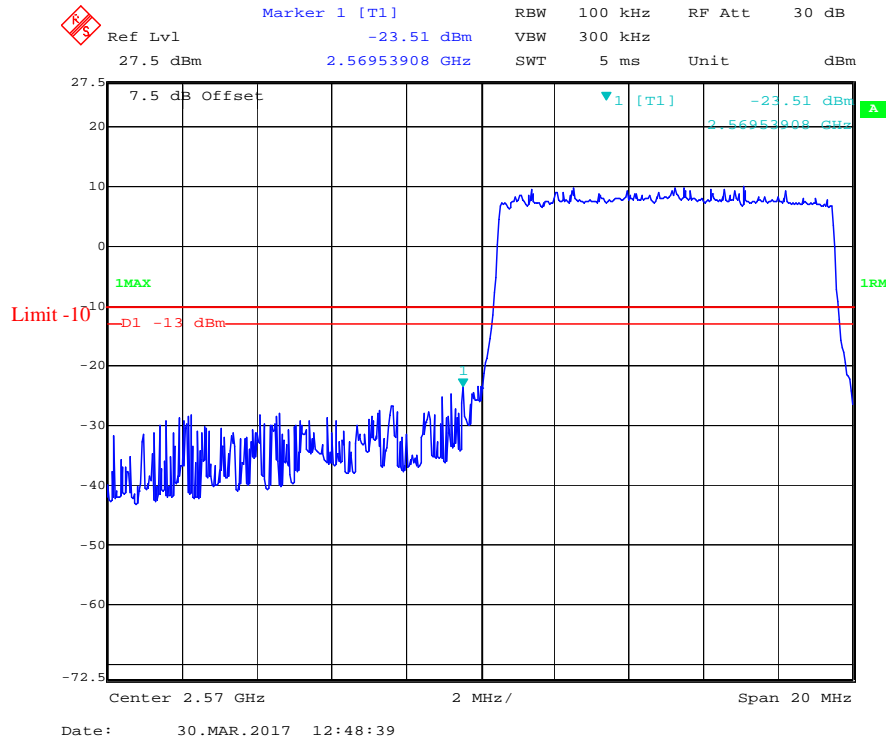

### 16-QAM (10.0 MHz, FULL RB) - Right Band Edge

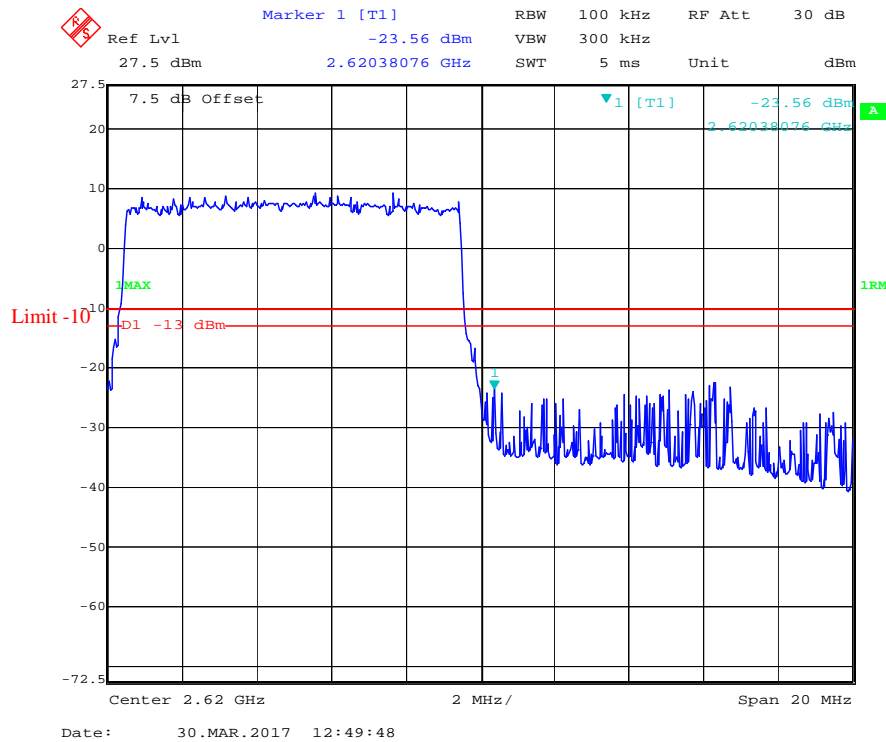

### QPSK (15 MHz, FULL RB) - Left Band Edge

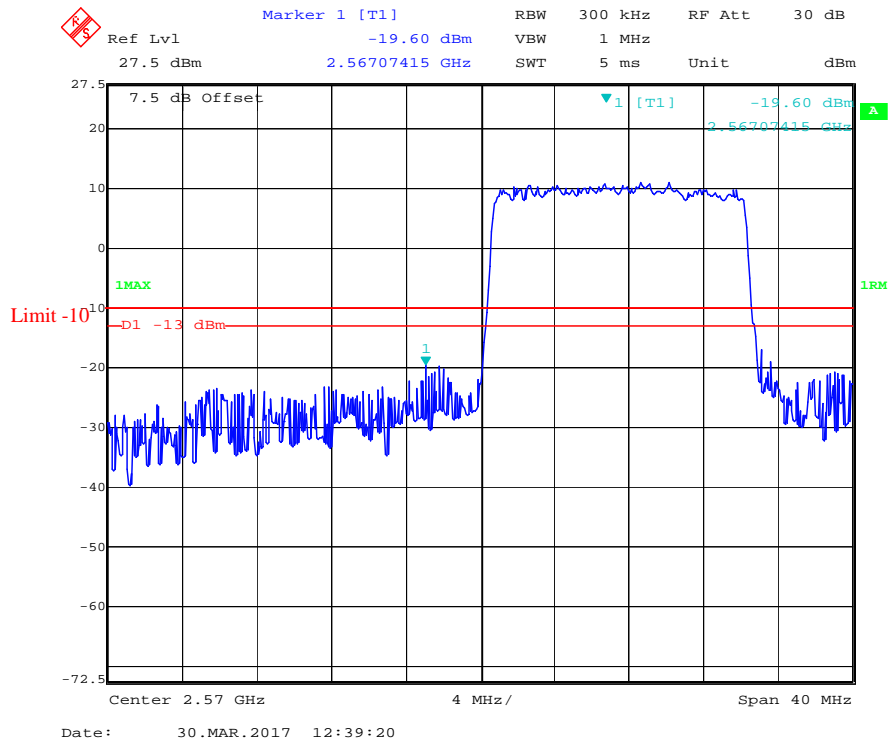

### QPSK (15 MHz, FULL RB) - Right Band Edge

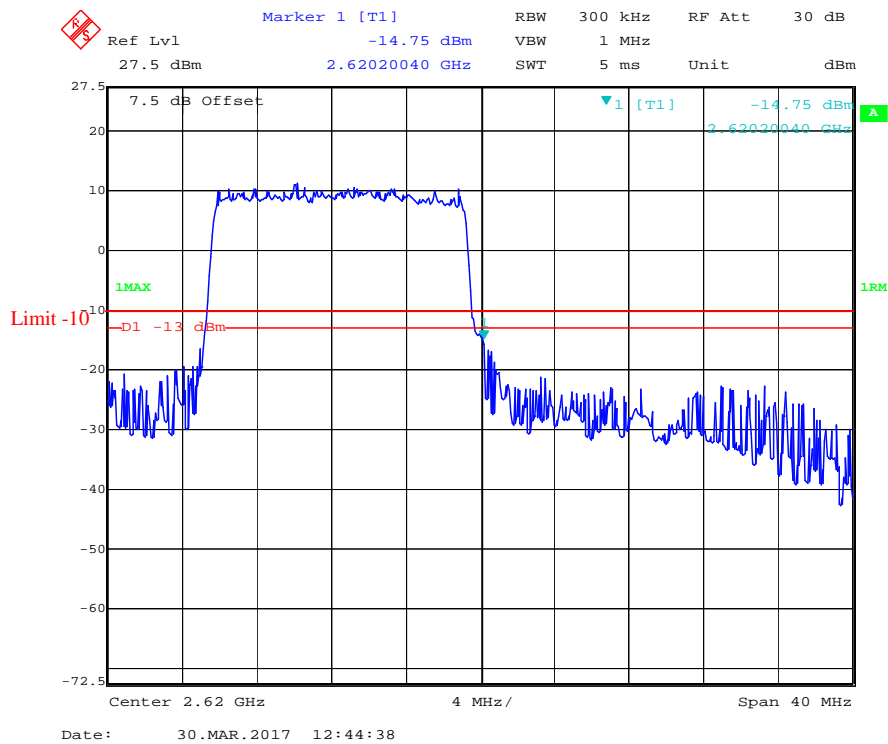



### 16-QAM (15 MHz, FULL RB) - Left Band Edge

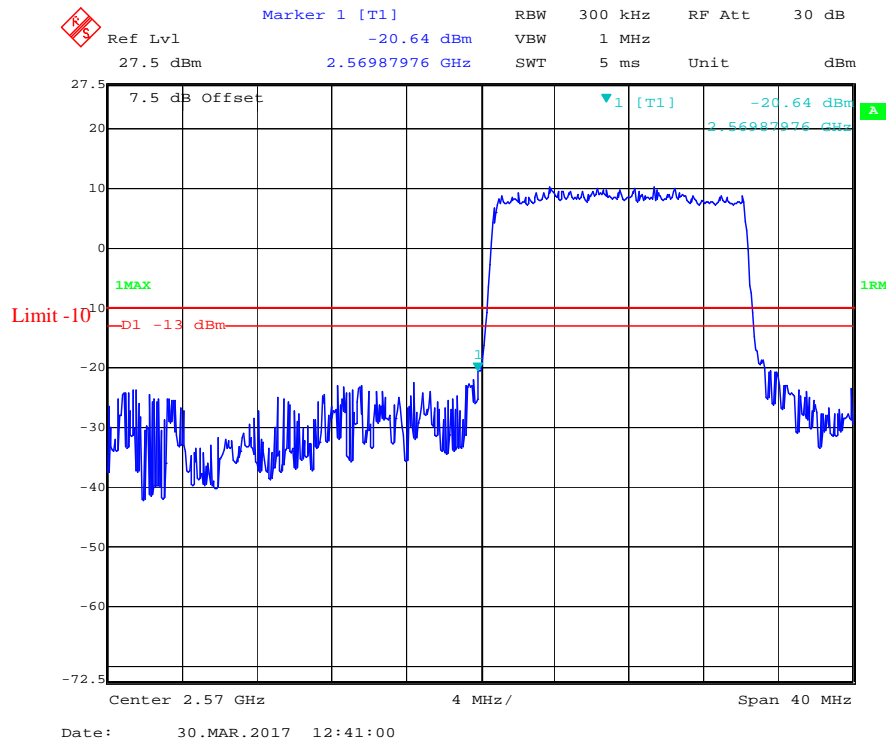

### 16-QAM (15 MHz, FULL RB) - Right Band Edge

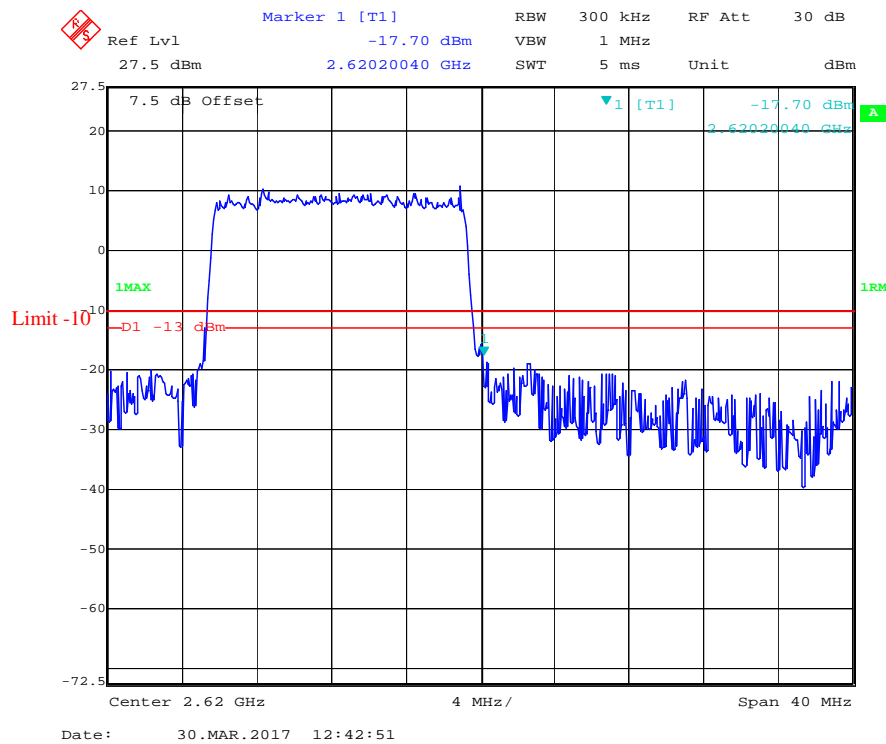

**QPSK (20 MHz, FULL RB) - Left Band Edge**

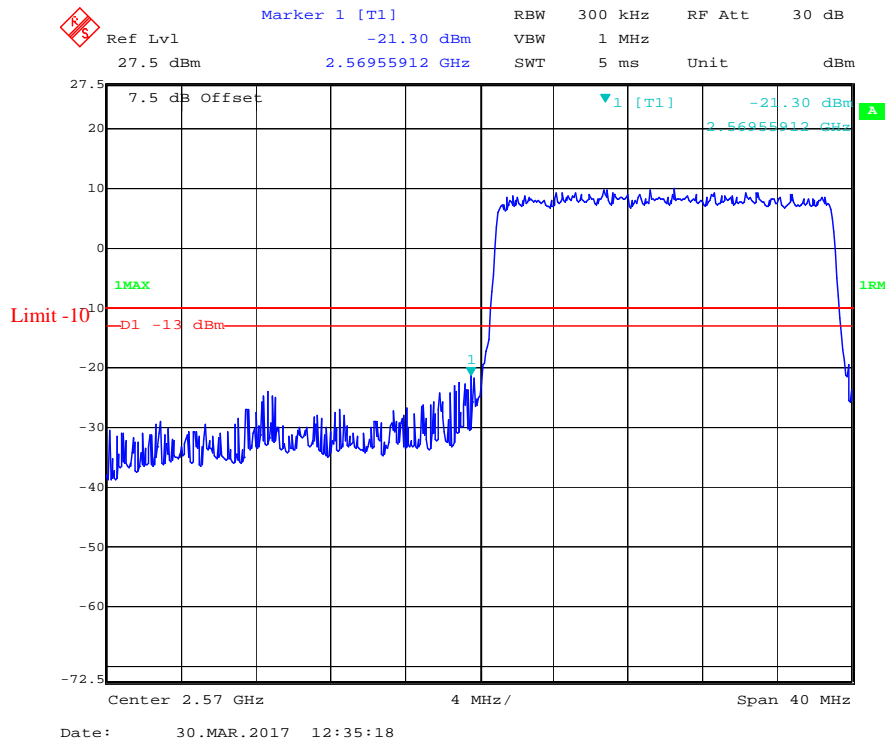

**QPSK (20 MHz, FULL RB) - Right Band Edge**

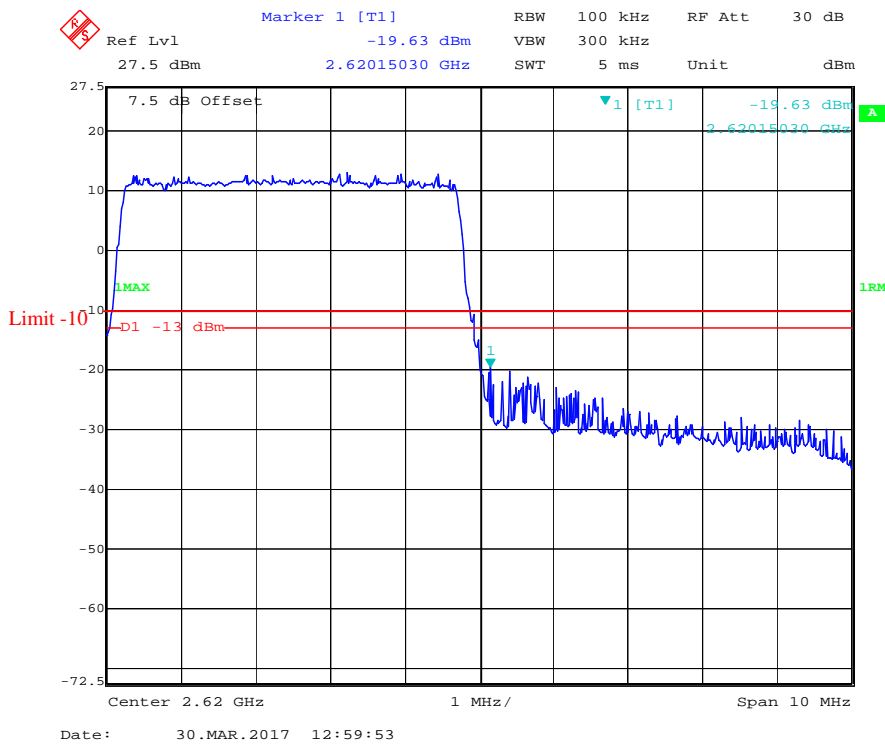

### 16-QAM (20 MHz, FULL RB) - Left Band Edge

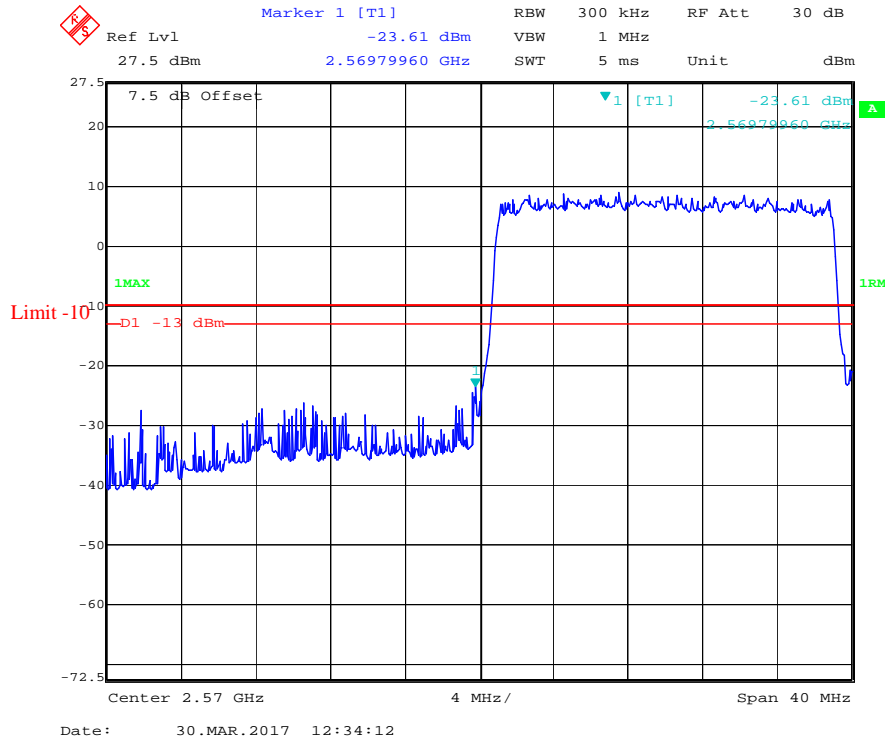

### 16-QAM (20 MHz, FULL RB) - Right Band Edge

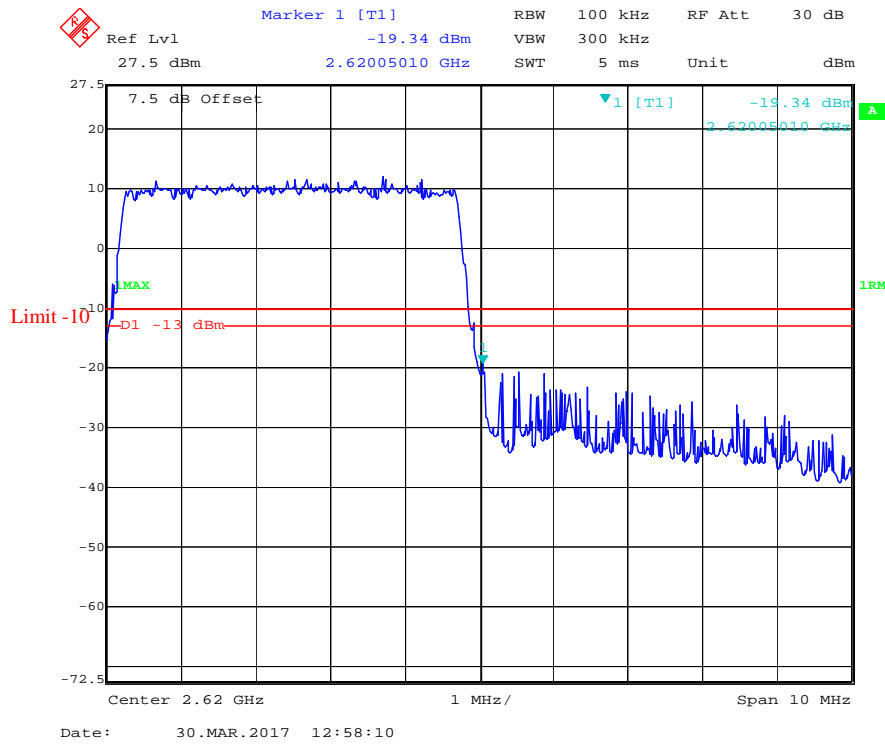

LTE Band 41:

QPSK (5.0 MHz, FULL RB) - Left Band Edge

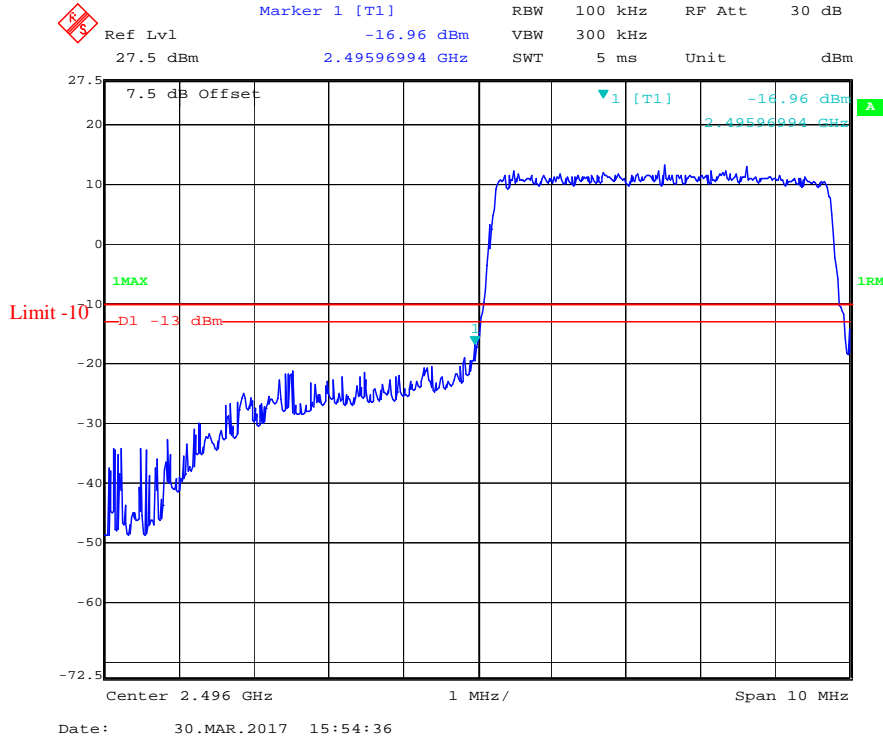

QPSK (5.0 MHz, FULL RB) - Right Band Edge

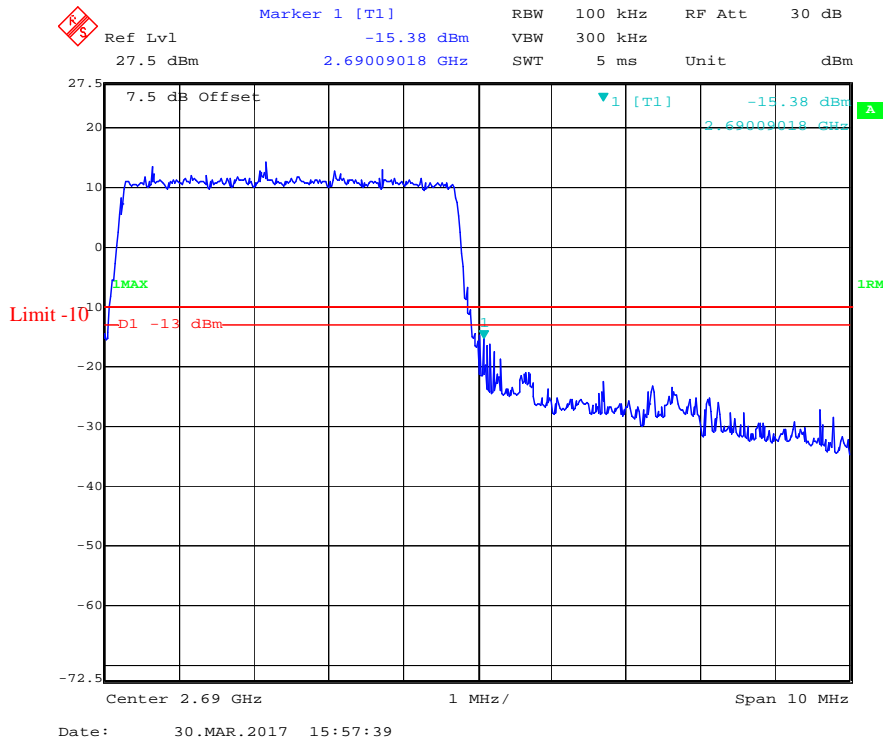

**16-QAM (5.0 MHz, FULL RB) - Left Band Edge**

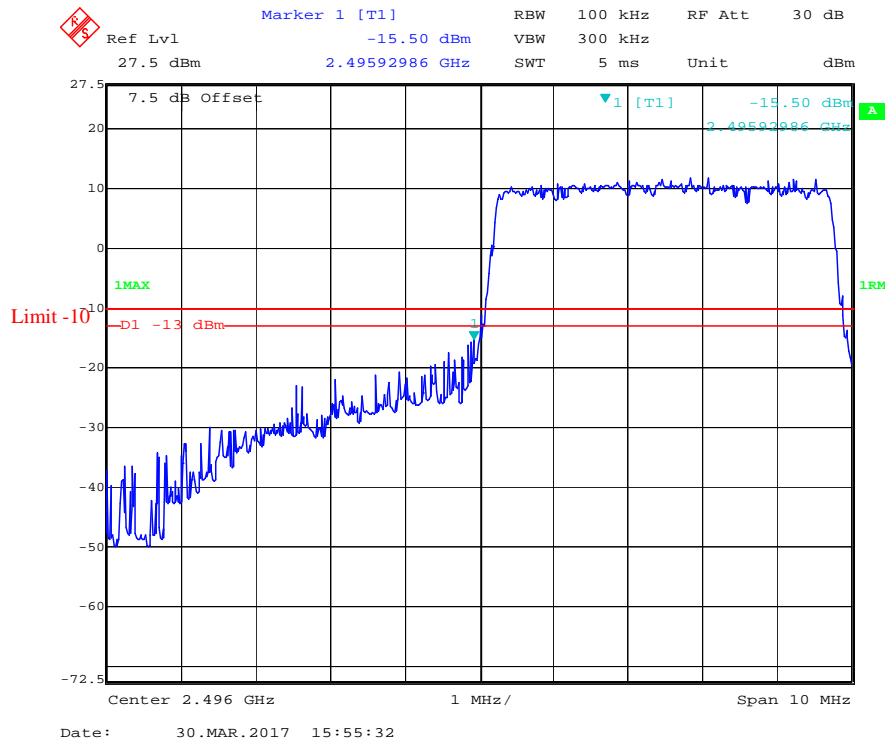

**16-QAM (5.0 MHz, FULL RB) - Right Band Edge**

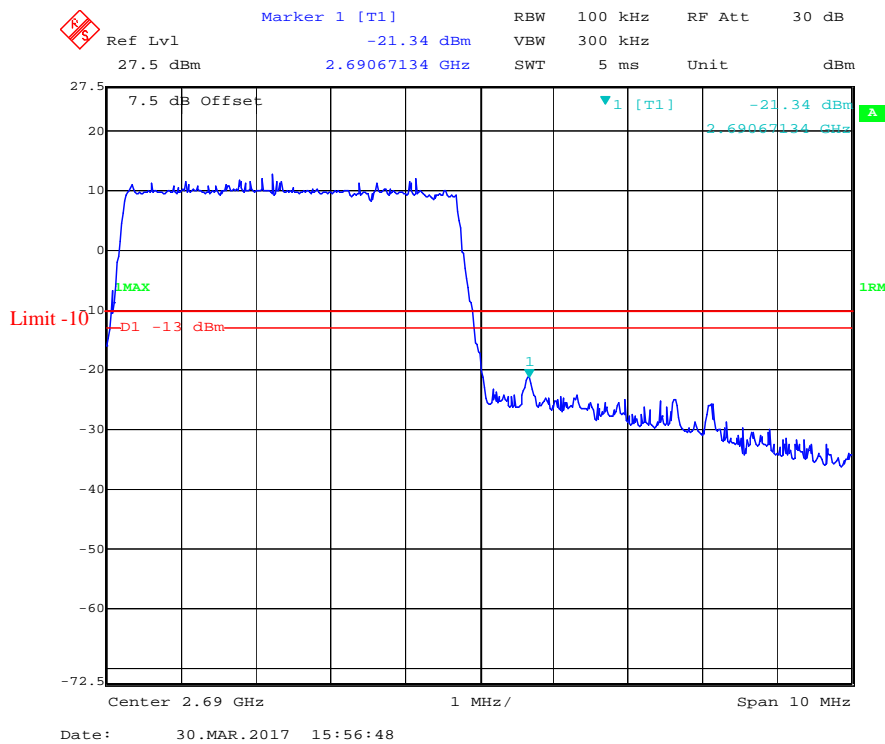

**QPSK (10.0 MHz, FULL RB) - Left Band Edge**

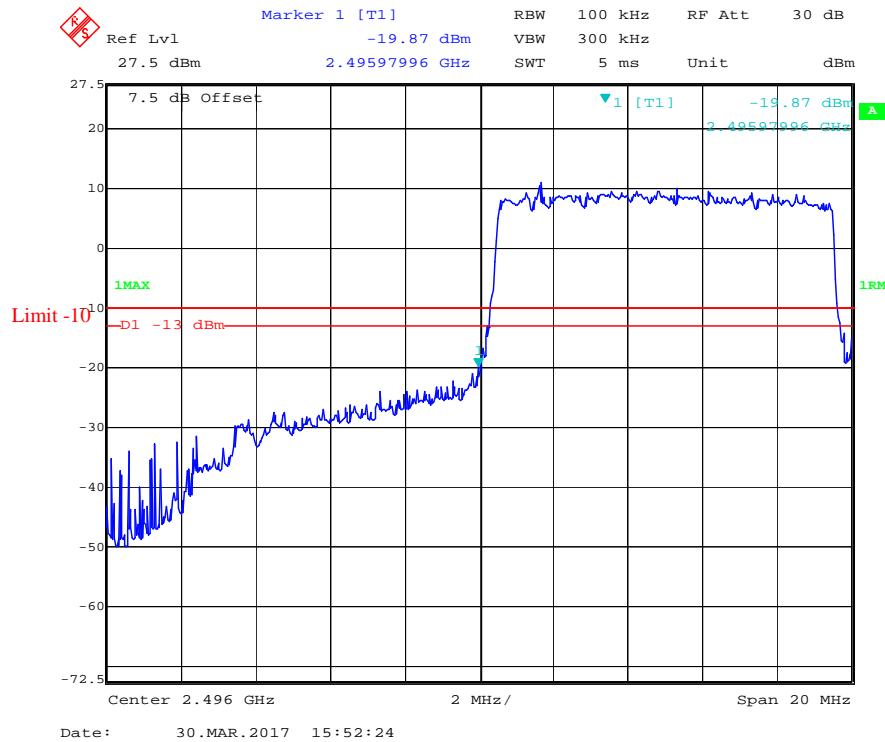

**QPSK (10.0 MHz, FULL RB) - Right Band Edge**

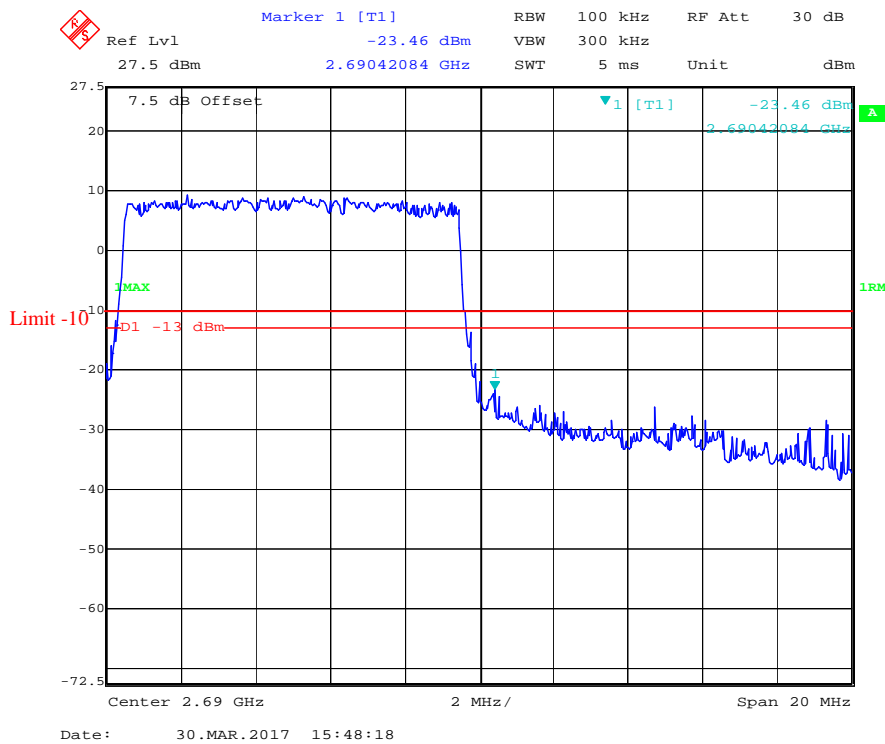

**16-QAM (10.0 MHz, FULL RB) - Left Band Edge**

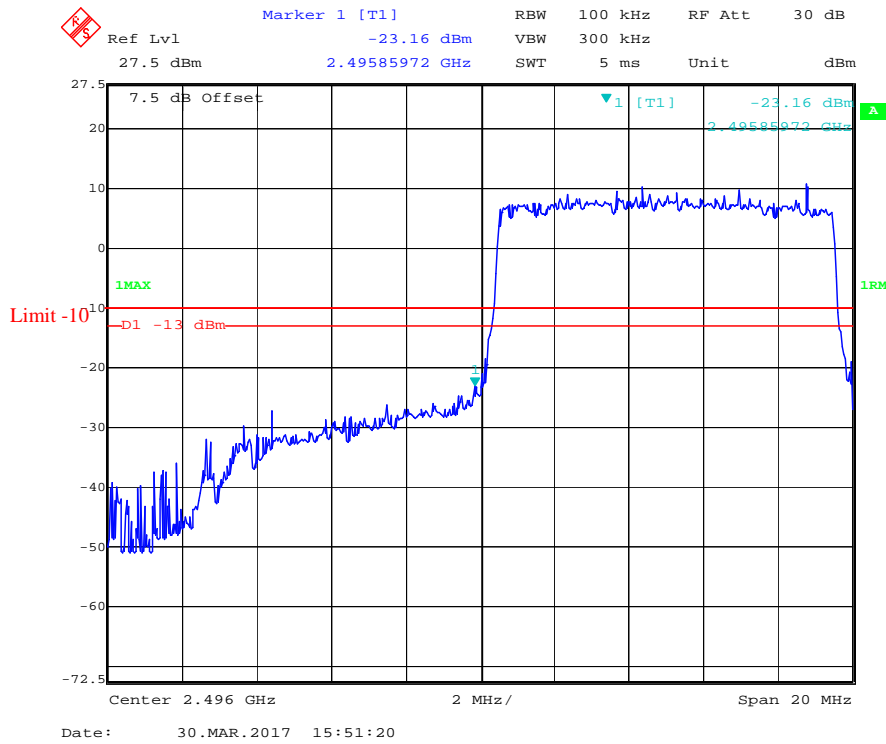

**16-QAM (10.0 MHz, FULL RB) - Right Band Edge**

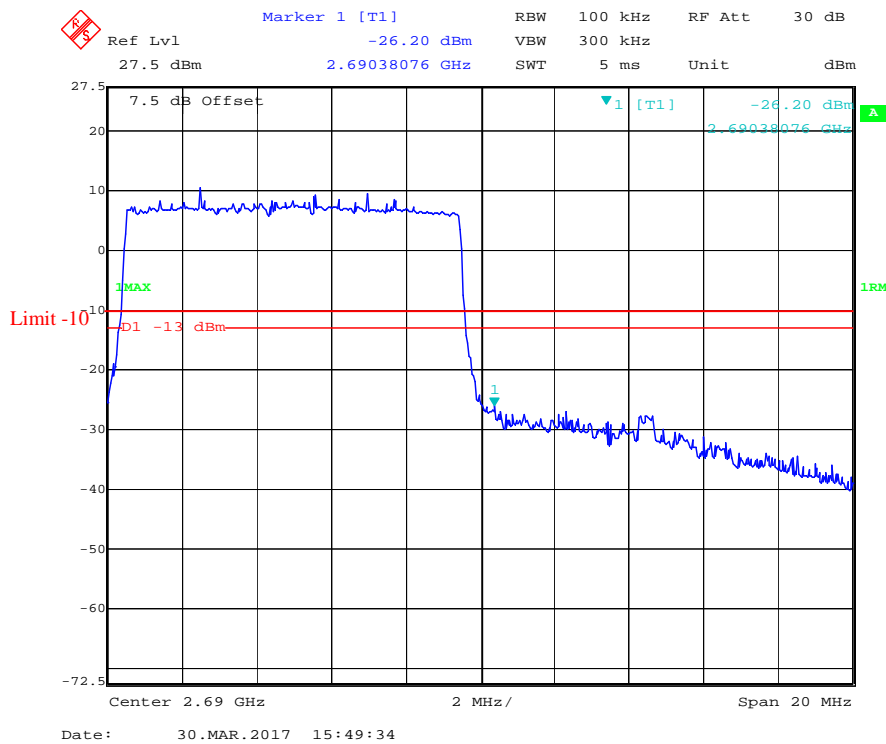

### QPSK (15 MHz, FULL RB) - Left Band Edge

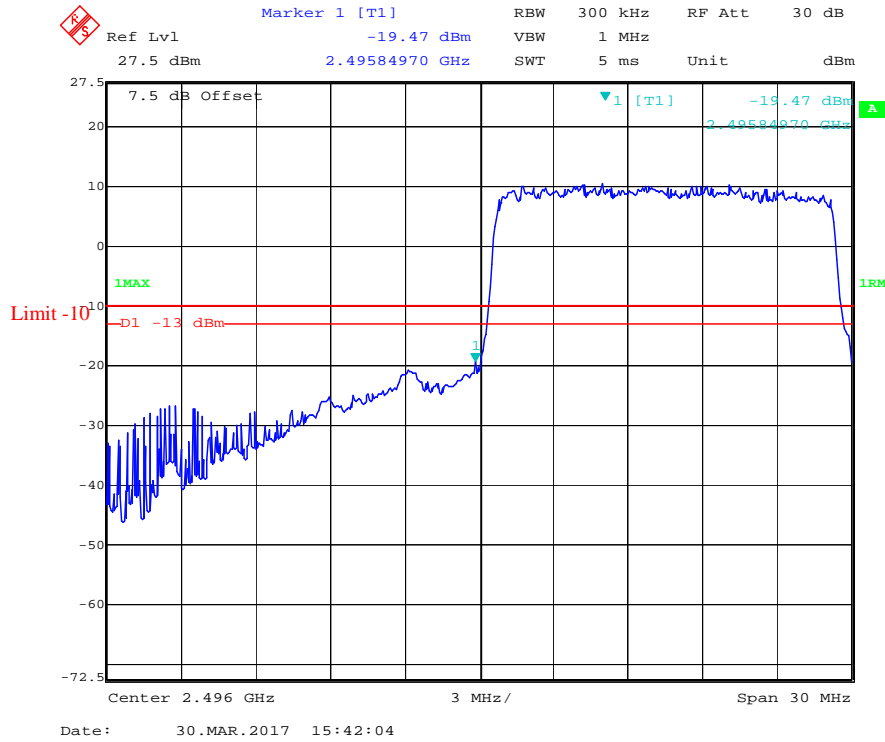

### QPSK (15 MHz, FULL RB) - Right Band Edge

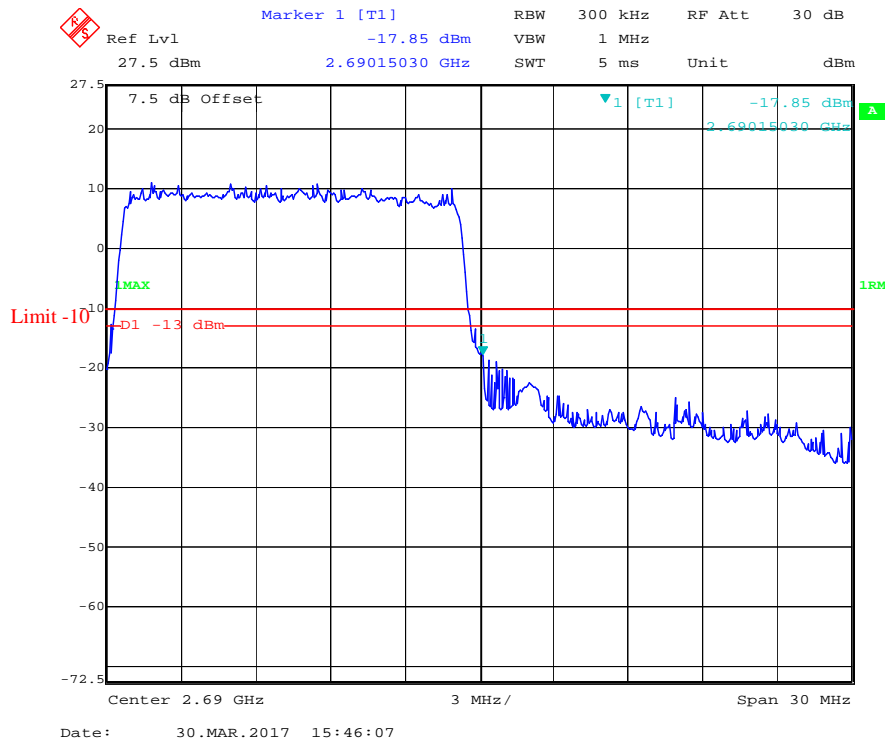



### 16-QAM (15 MHz, FULL RB) - Left Band Edge

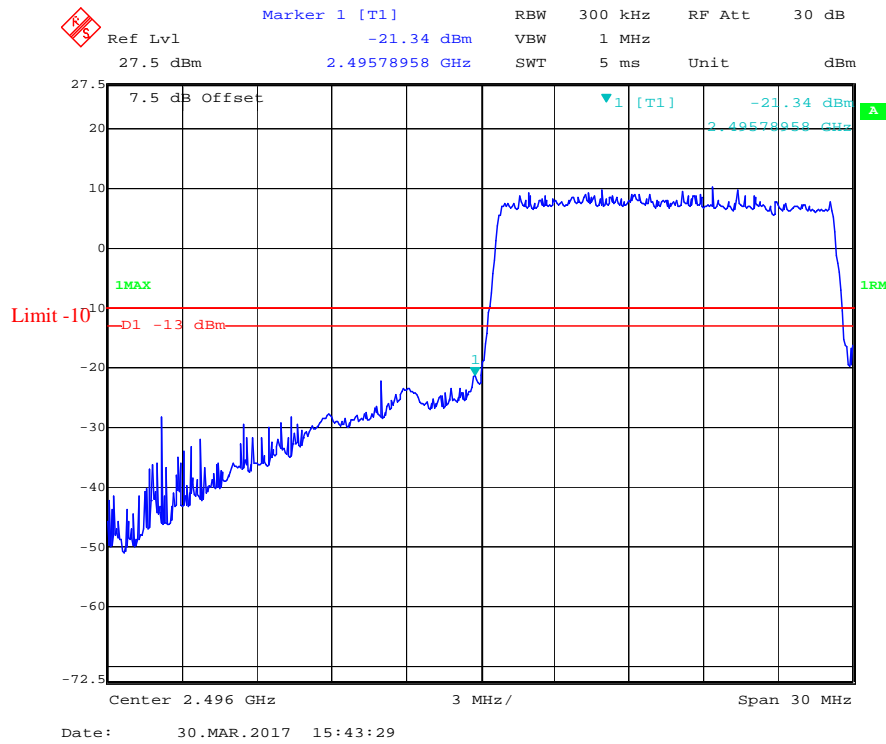

### 16-QAM (15 MHz, FULL RB) - Right Band Edge

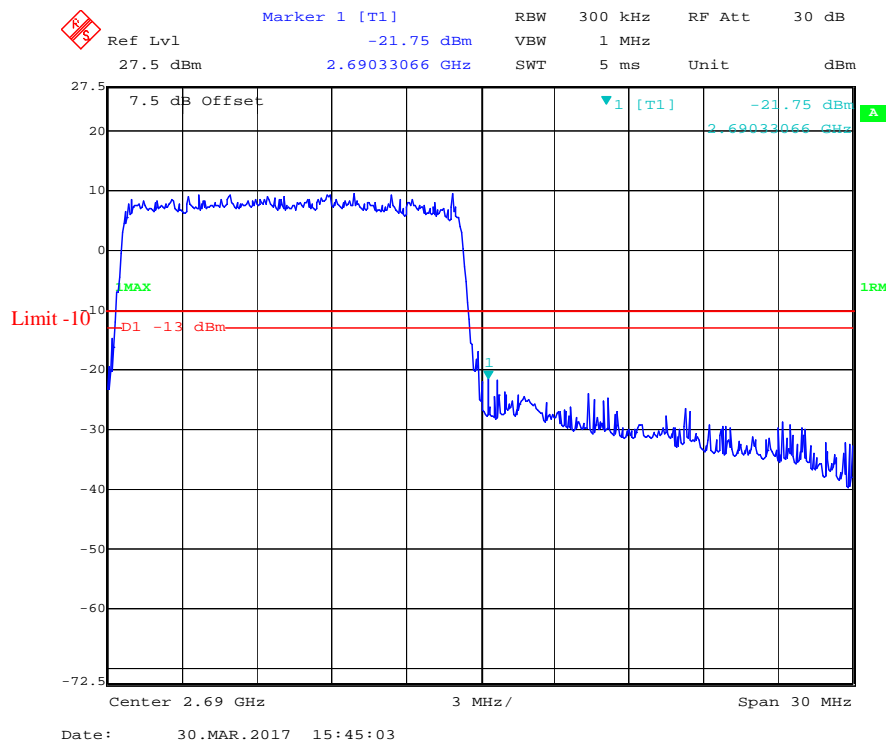

### QPSK (20 MHz, FULL RB) - Left Band Edge

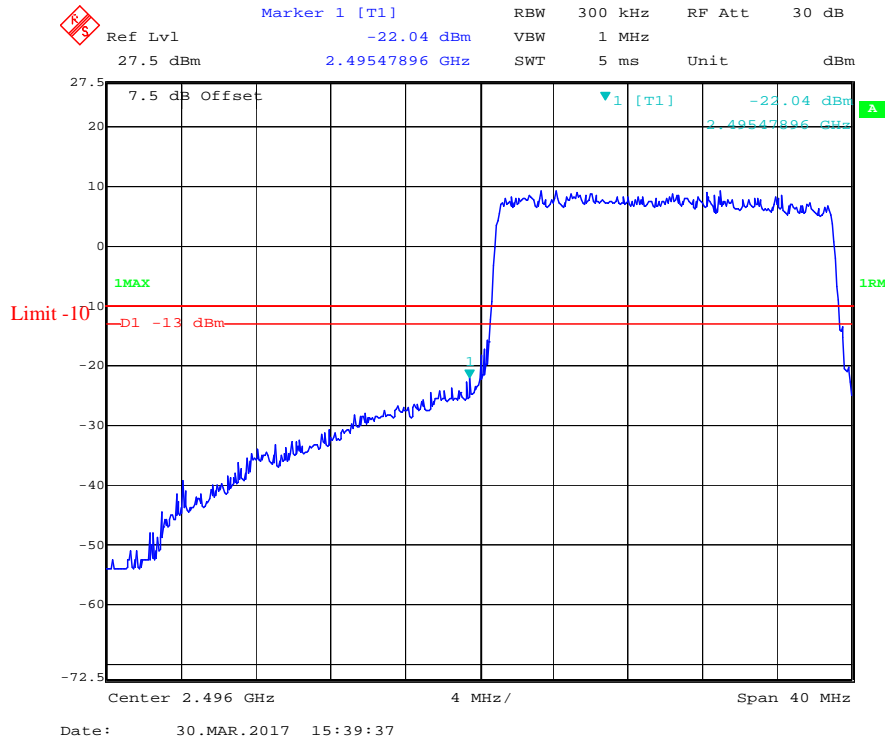

### QPSK (20 MHz, FULL RB) - Right Band Edge

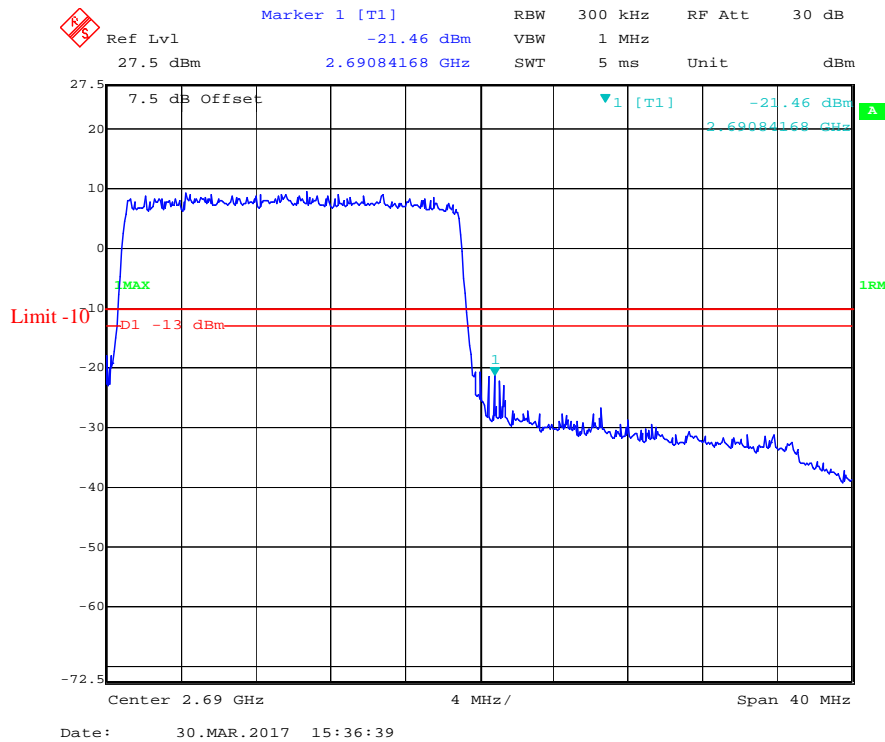

### 16-QAM (20 MHz, FULL RB) - Left Band Edge

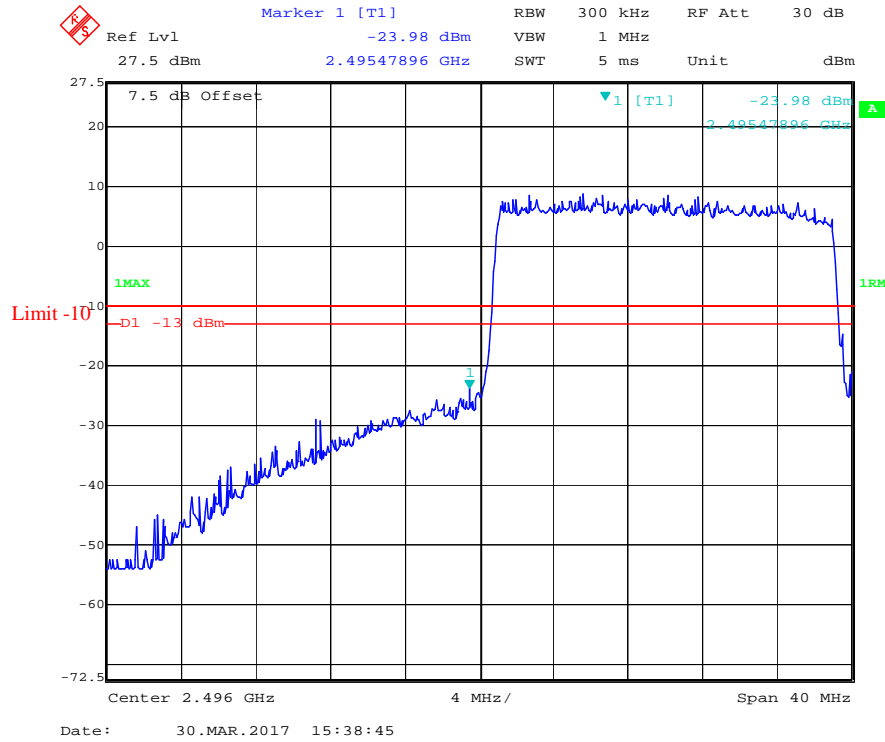

### 16-QAM (20 MHz, FULL RB) - Right Band Edge

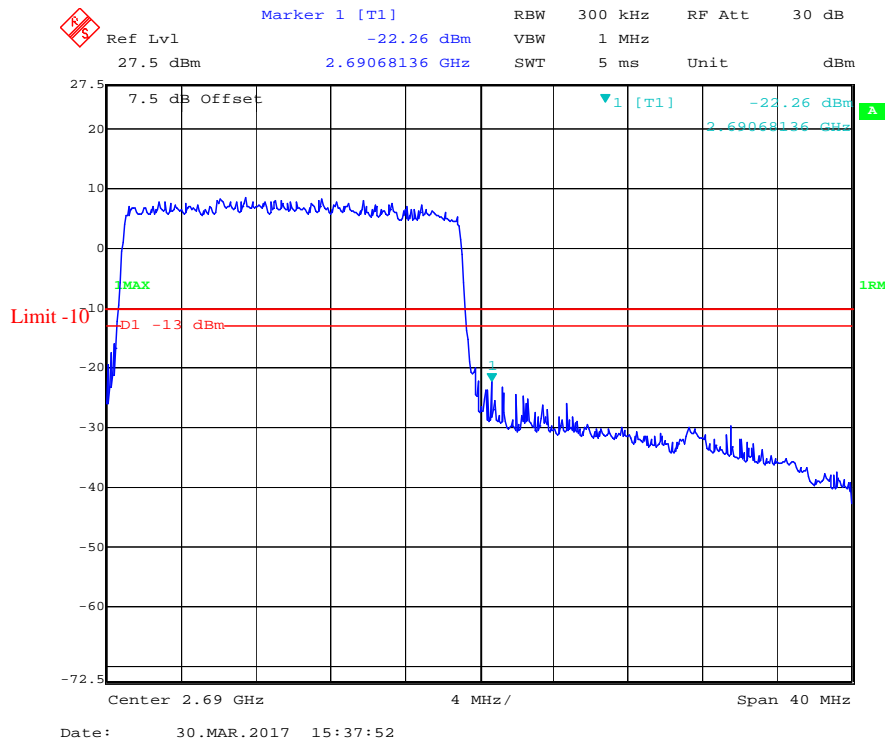

**FCC § 2.1055; § 22.355; § 24.235; §27.54; §90.213- FREQUENCY STABILITY**

**Applicable Standard**

FCC § 2.1055, §22.355, §24.235, §27.54 and §90.213.

According to FCC §2.1055, the frequency stability shall be sufficient to ensure that the fundamental emissions stay within the authorized bands of operation.

According to §22.355, the carrier frequency of each transmitter in the Public Mobile Services must be maintained within the tolerances given in Table below:

Frequency Tolerance for Transmitters in the Public Mobile Services

Frequency Range (MHz)	Base, fixed (ppm)	Mobile ≤ 3 watts (ppm)	Mobile > 3 watts (ppm)
25 to 50	20.0	20.0	50.0
50 to 450	5.0	5.0	50.0
450 to 512	2.5	5.0	5.0
821 to 896	1.5	2.5	2.5
928 to 929.	5.0	N/A	N/A
929 to 960.	1.5	N/A	N/A
2110 to 2220	10.0	N/A	N/A

According to §24.235, the frequency stability shall be sufficient to ensure that the fundamental emissions stays within the authorized frequency block.

According to §90.213:

Frequency range (MHz)	Fixed and base stations	Mobile stations	
		Over 2 watts output power	2 watts or less output power
Below 25	1 2 3 100	100	200
25-50	20	20	50
72-76	5		50
150-174	5 11 5	6 5	4 6 50
216-220	1.0		1.0
220-222 <sup>12</sup>	0.1	1.5	1.5
421-512	7 11 14 2.5	8 5	8 5
806-809	14 1.0	1.5	1.5
809-824	14 1.5	2.5	2.5
851-854	1.0	1.5	1.5
854-869	1.5	2.5	2.5
896-901	14 0.1	1.5	1.5
902-928	2.5	2.5	2.5
902-928 <sup>13</sup>	2.5	2.5	2.5
929-930	1.5		
935-940	0.1	1.5	1.5
1427-1435	9 300	300	300
Above 2450 <sup>10</sup>			

**Test Procedure**

Frequency Stability vs. Temperature: The equipment under test was connected to an external DC power supply and the RF output was connected to communication test set via feed-through attenuators. The EUT was placed inside the temperature chamber. The DC leads and RF output cable exited the chamber through an opening made for the purpose.

After the temperature stabilized for approximately 20 minutes, the frequency output was recorded from the communication test set.

Frequency Stability vs. Voltage: For hand carried, battery powered equipment; reduce primary supply voltage to the battery operating end point which shall be specified by the manufacturer.

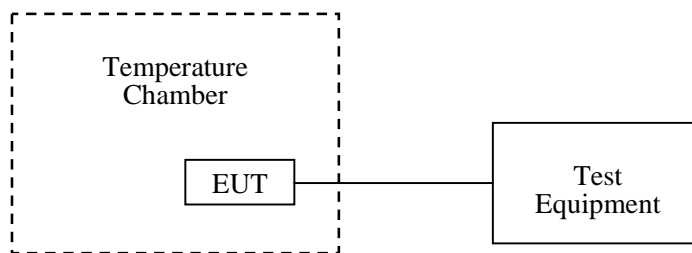

**Test Data**

**Environmental Conditions**

<b>Temperature:</b>	24 °C
<b>Relative Humidity:</b>	52 %
<b>ATM Pressure:</b>	101.0 kPa

*The testing was performed by Nefertari Xu on 2017-03-16.*

*EUT operation mode: Transmitting*

*Test Result: Compliance. Please refer to the following tables.*

**Cellular Band (Part 22H)**

**GSM Mode**

Middle Channel, $f_0 = 836.6\text{MHz}$				
Temperature (°C)	Power Supplied (V <sub>DC</sub> )	Frequency Error (Hz)	Frequency Error (ppm)	Limit (ppm)
-30	7.4	-9	-0.011	2.5
-20		-12	-0.014	2.5
-10		-3	-0.004	2.5
0		-8	-0.010	2.5
10		-10	-0.012	2.5
20		-5	-0.006	2.5
30		-9	-0.011	2.5
40		-4	-0.005	2.5
50		-7	-0.008	2.5
20	V <sub>min.</sub> = 6.4	3	0.004	2.5

**EDGE Mode**

Middle Channel, $f_0 = 836.6\text{MHz}$				
Temperature (°C)	Power Supplied (V <sub>DC</sub> )	Frequency Error (Hz)	Frequency Error (ppm)	Limit (ppm)
-30	7.4	6	0.007	2.5
-20		18	0.022	2.5
-10		13	0.016	2.5
0		14	0.017	2.5
10		7	0.008	2.5
20		9	0.011	2.5
30		6	0.007	2.5
40		10	0.012	2.5
50		12	0.014	2.5
20	V <sub>min.</sub> = 6.4	17	0.020	2.5

**CDMA Mode**

Middle Channel, $f_o = 836.52\text{MHz}$				
Temperature (°C)	Power Supplied ( $V_{DC}$ )	Frequency Error (Hz)	Frequency Error (ppm)	Limit (ppm)
-30	7.4	-2	-0.0024	2.5
-20		-4	-0.0048	2.5
-10		-2	-0.0024	2.5
0		-5	-0.0060	2.5
10		-7	-0.0084	2.5
20		-3	-0.0036	2.5
30		-2	-0.0024	2.5
40		-3	-0.0036	2.5
50		-1	-0.0012	2.5
20	$V_{min.} = 6.4$	0	0.0000	2.5

**CDMA (EV-DO) Mode**

Middle Channel, $f_o = 836.52\text{MHz}$				
Temperature (°C)	Power Supplied ( $V_{DC}$ )	Frequency Error (Hz)	Frequency Error (ppm)	Limit (ppm)
-30	7.4	-3	-0.0036	2.5
-20		-1	-0.0012	2.5
-10		-3	-0.0036	2.5
0		-2	-0.0024	2.5
10		-3	-0.0036	2.5
20		-4	-0.0048	2.5
30		-1	-0.0012	2.5
40		-2	-0.0024	2.5
50		-4	-0.0048	2.5
20	$V_{min.} = 6.4$	0	0.0000	2.5

**PCS Band (Part 24E)****GSM Mode**

Middle Channel, $f_o = 1880.0$ MHz				
Temperature (°C)	Power Supplied (V <sub>DC</sub> )	Frequency Error (Hz)	Frequency Error (ppm)	Result
-30	7.4	8	0.0043	pass
-20		13	0.0069	pass
-10		5	0.0027	pass
0		10	0.0053	pass
10		11	0.0059	pass
20		8	0.0043	pass
30		4	0.0021	pass
40		9	0.0048	pass
50		6	0.0032	pass
20	V <sub>min.</sub> = 6.4	7	0.0037	pass

**EDGE Mode**

Middle Channel, $f_o = 1880.0$ MHz				
Temperature (°C)	Power Supplied (V <sub>DC</sub> )	Frequency Error (Hz)	Frequency Error (ppm)	Result
-30	7.4	15	0.0080	pass
-20		10	0.0053	pass
-10		11	0.0059	pass
0		13	0.0069	pass
10		15	0.0080	pass
20		9	0.0048	pass
30		4	0.0021	pass
40		7	0.0037	pass
50		6	0.0032	pass
20	V <sub>min.</sub> = 6.4	4	0.0021	pass



**LTE Band 2: QPSK**

10.0 MHz Middle Channel, $f_0 = 1880\text{MHz}$				
Temperature (°C)	Power Supplied (V <sub>DC</sub> )	Frequency Error (Hz)	Frequency Error (ppm)	Result
-30	7.4	-4.86	-0.00259	pass
-20		-4.75	-0.00253	pass
-10		-4.24	-0.00226	pass
0		-4.19	-0.00223	pass
10		-4.14	-0.00220	pass
20		-4.21	-0.00224	pass
30		-4.18	-0.00222	pass
40		-4.06	-0.00216	pass
50		-4.45	-0.00237	pass
20	V <sub>min</sub> = 6.4	-4.38	-0.00233	pass

**LTE Band 4: QPSK**

10.0 MHz Middle Channel, $f_0 = 1732.5\text{ MHz}$				
Temperature (°C)	Power Supplied (V <sub>DC</sub> )	Frequency Error (Hz)	Frequency Error (ppm)	Result
-30	7.4	0.29	0.00017	pass
-20		0.41	0.00024	pass
-10		0.36	0.00021	pass
0		0.52	0.00030	pass
10		0.50	0.00029	pass
20		0.56	0.00032	pass
30		0.45	0.00026	pass
40		0.56	0.00032	pass
50		0.65	0.00038	pass
20	V <sub>min</sub> = 6.4	0.42	0.00024	pass

**LTE Band 5: QPSK**

10.0 MHz Middle Channel, $f_o = 836.5$ MHz				
Temperature (°C)	Power Supplied (V <sub>DC</sub> )	Frequency Error (Hz)	Frequency Error (ppm)	Limit (ppm)
-30	7.4	-2.02	-0.00241	2.5
-20		-1.90	-0.00227	2.5
-10		-1.82	-0.00218	2.5
0		-1.99	-0.00238	2.5
10		-1.65	-0.00197	2.5
20		-1.78	-0.00213	2.5
30		-1.95	-0.00233	2.5
40		-1.87	-0.00224	2.5
50		-1.58	-0.00189	2.5
20	V <sub>min.</sub> = 6.4	-1.34	-0.00160	2.5

**LTE Band 7: QPSK**

10.0 MHz Middle Channel, $f_o = 2535$ MHz				
Temperature (°C)	Power Supplied (V <sub>DC</sub> )	Frequency Error (Hz)	Frequency Error (ppm)	Result
-30	7.4	-4.03	-0.00159	pass
-20		-4.18	-0.00165	pass
-10		-3.16	-0.00125	pass
0		-3.40	-0.00134	pass
10		-3.96	-0.00156	pass
20		-3.79	-0.00150	pass
30		-3.15	-0.00124	pass
40		-3.69	-0.00146	pass
50		-3.70	-0.00151	pass
20	V <sub>min.</sub> = 6.4	-3.98	-0.00157	pass

**LTE Band 26: QPSK**

10.0 MHz Middle Channel, $f_0 = 819$ MHz				
Temperature (°C)	Power Supplied (V <sub>DC</sub> )	Frequency Error (Hz)	Frequency Error (ppm)	Limit (ppm)
-30	7.4	-2.07	-0.0025	2.5
-20		-1.95	-0.0024	2.5
-10		-1.87	-0.0023	2.5
0		-1.91	-0.0023	2.5
10		-1.84	-0.0022	2.5
20		-1.79	-0.0022	2.5
30		-1.76	-0.0021	2.5
40		-1.55	-0.0019	2.5
50		-1.31	-0.0016	2.5
20	V <sub>min.</sub> = 6.4	-1.38	-0.0017	2.5

**LTE Band 38: QPSK**

10.0 MHz Middle Channel, $f_0 = 2595$ MHz				
Temperature (°C)	Power Supplied (V <sub>DC</sub> )	Frequency Error (Hz)	Frequency Error (ppm)	Result
-30	7.4	4.30	0.0017	pass
-20		4.78	0.0018	pass
-10		5.08	0.0020	pass
0		4.03	0.0016	pass
10		4.18	0.0016	pass
20		4.67	0.0018	pass
30		4.35	0.0017	pass
40		4.87	0.0019	pass
50		4.55	0.0018	pass
20	V <sub>min.</sub> = 6.4	4.51	0.0017	pass

**LTE Band 41: QPSK**

<b>10.0 MHz Middle Channel, <math>f_o = 2593</math> MHz</b>				
<b>Temperature (°C)</b>	<b>Power Supplied (V<sub>DC</sub>)</b>	<b>Frequency Error (Hz)</b>	<b>Frequency Error (ppm)</b>	<b>Result</b>
-30	7.4	6.65	0.0026	pass
-20		7.38	0.0028	pass
-10		7.24	0.0028	pass
0		6.98	0.0027	pass
10		6.18	0.0024	pass
20		6.91	0.0027	pass
30		7.19	0.0028	pass
40		7.10	0.0027	pass
50		6.08	0.0023	pass
20		V <sub>min.</sub> = 6.4	6.32	0.0024

**\*\*\*\*\* END OF REPORT \*\*\*\*\***