

**Test Plot 1#: PTT\_FM 12.5KHz\_Face Up\_136.0125 MHz****DUT: Digital Portable Radio; Type: PD782G VHF; Serial: 17090701320**

Communication System: FM; Frequency: 136.012 MHz; Duty Cycle: 1:1

Medium parameters used:  $f = 136.012$  MHz;  $\sigma = 0.771$  S/m;  $\epsilon_r = 53.208$ ;  $\rho = 1000$  kg/m<sup>3</sup>

Phantom section: Flat Section

DASY5 Configuration:

- Probe: EX3DV4 - SN7441; ConvF(13.25, 13.25, 13.25); Calibrated: 2016/11/15;
- Sensor-Surface: 1.4mm (Mechanical Surface Detection)
- Electronics: DAE4 Sn772; Calibrated: 2016/10/25
- Phantom: ELI v8.0; Type: QDOVA004AA; Serial: 2051
- Measurement SW: DASY52, Version 52.8 (8);

**Area Scan (71x141x1):** Interpolated grid: dx=1.500 mm, dy=1.500 mm

Maximum value of SAR (interpolated) = 3.53 W/kg

**Zoom Scan (5x5x7)/Cube 0:** Measurement grid: dx=8mm, dy=8mm, dz=5mm

Reference Value = 53.55 V/m; Power Drift = -0.11 dB

Peak SAR (extrapolated) = 4.10 W/kg

**SAR(1 g) = 2.67 W/kg; SAR(10 g) = 2.03 W/kg**

Maximum value of SAR (measured) = 3.47 W/kg

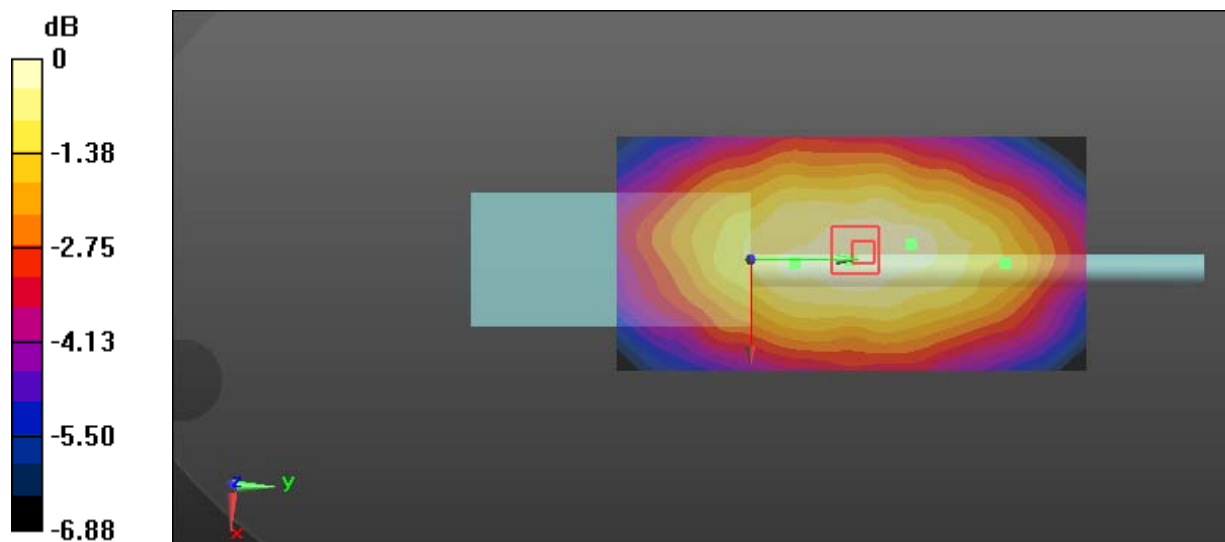

0 dB = 3.47 W/kg = 5.40 dBW/kg

**Test Plot 2#: PTT\_FM 12.5KHz\_Face Up\_147.0125 MHz****DUT: Digital Portable Radio; Type: PD782G VHF; Serial: 17090701320**

Communication System: FM; Frequency: 147.012 MHz; Duty Cycle: 1:1

Medium parameters used:  $f = 147.012$  MHz;  $\sigma = 0.782$  S/m;  $\epsilon_r = 53.179$ ;  $\rho = 1000$  kg/m<sup>3</sup>

Phantom section: Flat Section

DASY5 Configuration:

- Probe: EX3DV4 - SN7441; ConvF(13.25, 13.25, 13.25); Calibrated: 2016/11/15;
- Sensor-Surface: 1.4mm (Mechanical Surface Detection)
- Electronics: DAE4 Sn772; Calibrated: 2016/10/25
- Phantom: ELI v8.0; Type: QDOVA004AA; Serial: 2051
- Measurement SW: DASY52, Version 52.8 (8);

**Area Scan (71x141x1):** Interpolated grid: dx=1.500 mm, dy=1.500 mm

Maximum value of SAR (interpolated) = 4.01 W/kg

**Zoom Scan (5x5x7)/Cube 0:** Measurement grid: dx=8mm, dy=8mm, dz=5mm

Reference Value = 59.04 V/m; Power Drift = -0.20 dB

Peak SAR (extrapolated) = 4.78 W/kg

**SAR(1 g) = 3.01 W/kg; SAR(10 g) = 2.31 W/kg**

Maximum value of SAR (measured) = 4.03 W/kg

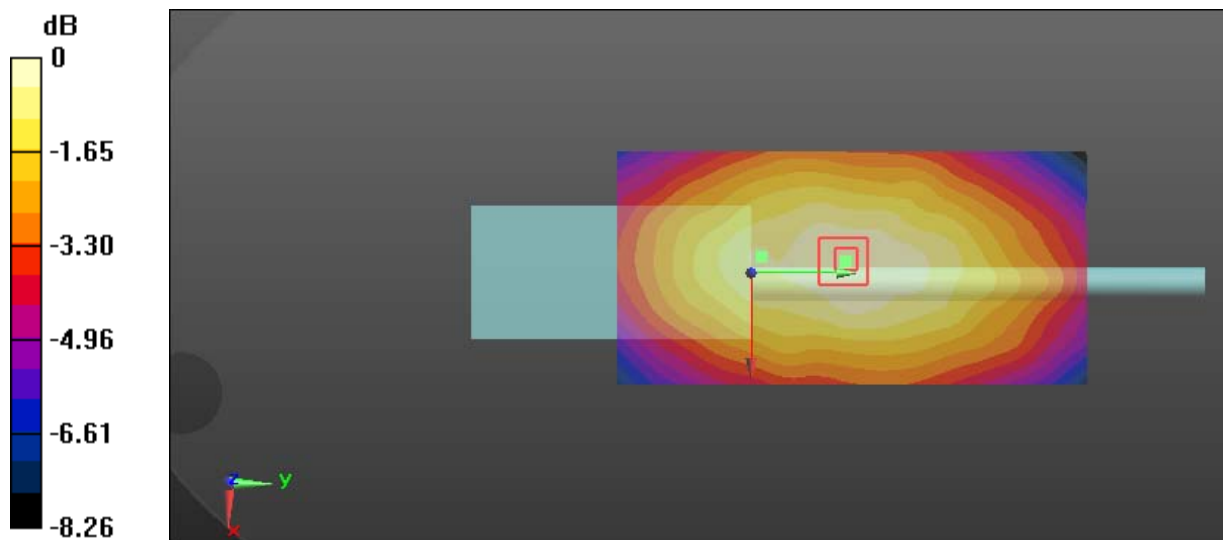

0 dB = 4.03 W/kg = 6.05 dBW/kg

**Test Plot 3#: PTT\_FM 12.5KHz\_Face Up\_160.0125 MHz****DUT: Digital Portable Radio; Type: PD782G VHF; Serial: 17090701320**

Communication System: FM; Frequency: 160.012 MHz; Duty Cycle: 1:1

Medium parameters used:  $f = 160.012$  MHz;  $\sigma = 0.792$  S/m;  $\epsilon_r = 52.977$ ;  $\rho = 1000$  kg/m<sup>3</sup>

Phantom section: Flat Section

DASY5 Configuration:

- Probe: EX3DV4 - SN7441; ConvF(13.25, 13.25, 13.25); Calibrated: 2016/11/15;
- Sensor-Surface: 1.4mm (Mechanical Surface Detection)
- Electronics: DAE4 Sn772; Calibrated: 2016/10/25
- Phantom: ELI v8.0; Type: QDOVA004AA; Serial: 2051
- Measurement SW: DASY52, Version 52.8 (8);

**Area Scan (71x141x1):** Interpolated grid: dx=1.500 mm, dy=1.500 mm

Maximum value of SAR (interpolated) = 4.24 W/kg

**Zoom Scan (5x5x7)/Cube 0:** Measurement grid: dx=8mm, dy=8mm, dz=5mm

Reference Value = 58.94 V/m; Power Drift = -0.05 dB

Peak SAR (extrapolated) = 4.96 W/kg

**SAR(1 g) = 3.12 W/kg; SAR(10 g) = 2.42 W/kg**

Maximum value of SAR (measured) = 4.10 W/kg

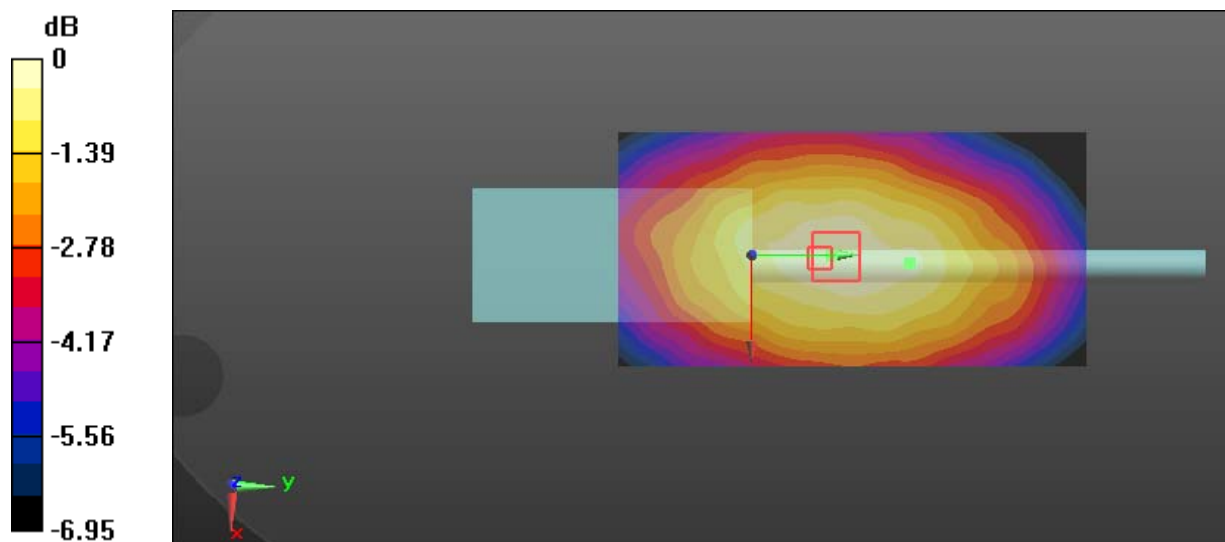

0 dB = 4.10 W/kg = 6.13 dBW/kg

**Test Plot 4#: PTT\_FM 12.5KHz\_Body Back\_136.0125 MHz****DUT: Digital Portable Radio; Type: PD782G VHF; Serial: 17090701320**

Communication System: FM; Frequency: 136.012 MHz; Duty Cycle: 1:1

Medium parameters used:  $f = 136.012$  MHz;  $\sigma = 0.817$  S/m;  $\epsilon_r = 60.796$ ;  $\rho = 1000$  kg/m<sup>3</sup>

Phantom section: Flat Section

DASY5 Configuration:

- Probe: EX3DV4 - SN7441; ConvF(12.58, 12.58, 12.58); Calibrated: 2016/11/15;
- Sensor-Surface: 1.4mm (Mechanical Surface Detection)
- Electronics: DAE4 Sn772; Calibrated: 2016/10/25
- Phantom: ELI v8.0; Type: QDOVA004AA; Serial: 2051
- Measurement SW: DASY52, Version 52.8 (8);

**Area Scan (71x141x1):** Interpolated grid: dx=1.500 mm, dy=1.500 mm

Maximum value of SAR (interpolated) = 16.2 W/kg

**Zoom Scan (5x5x7)/Cube 0:** Measurement grid: dx=8mm, dy=8mm, dz=5mm

Reference Value = 87.02 V/m; Power Drift = -0.02 dB

Peak SAR (extrapolated) = 23.6 W/kg

**SAR(1 g) = 8.39 W/kg; SAR(10 g) = 4.73 W/kg**

Maximum value of SAR (measured) = 15.9 W/kg

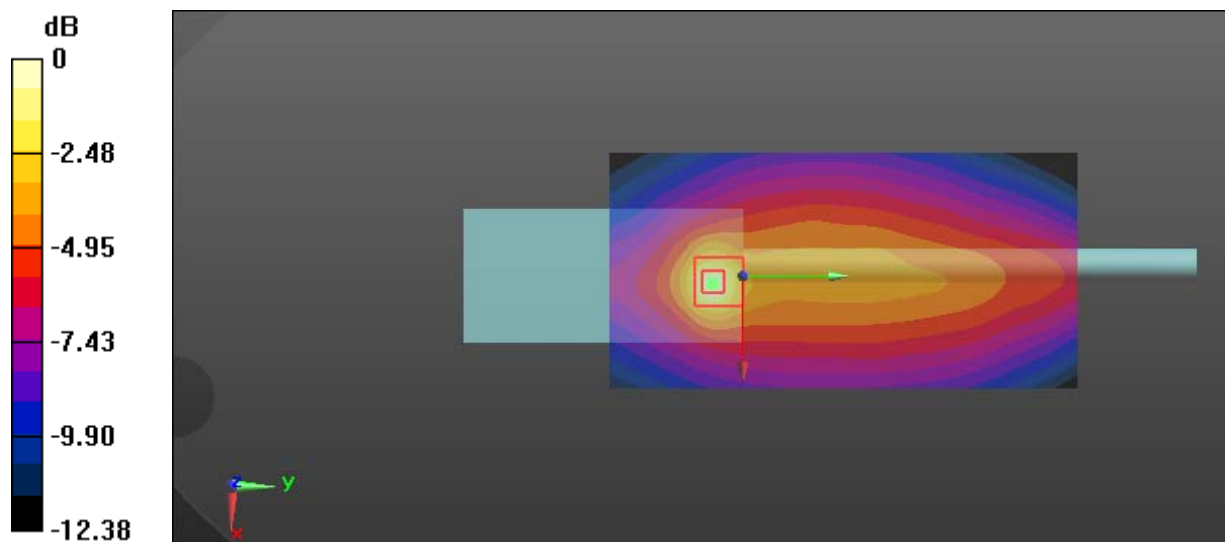

0 dB = 15.9 W/kg = 12.01 dBW/kg

**Test Plot 5#: PTT\_FM 12.5KHz\_Body Back\_141 MHz****DUT: Digital Portable Radio; Type: PD782G VHF; Serial: 17090701320**

Communication System: FM; Frequency: 141 MHz; Duty Cycle: 1:1

Medium parameters used:  $f = 141$  MHz;  $\sigma = 0.819$  S/m;  $\epsilon_r = 60.781$ ;  $\rho = 1000$  kg/m<sup>3</sup>

Phantom section: Flat Section

DASY5 Configuration:

- Probe: EX3DV4 - SN7441; ConvF(12.58, 12.58, 12.58); Calibrated: 2016/11/15;
- Sensor-Surface: 1.4mm (Mechanical Surface Detection)
- Electronics: DAE4 Sn772; Calibrated: 2016/10/25
- Phantom: ELI v8.0; Type: QDOVA004AA; Serial: 2051
- Measurement SW: DASY52, Version 52.8 (8);

**Area Scan (71x141x1):** Interpolated grid: dx=1.500 mm, dy=1.500 mm

Maximum value of SAR (interpolated) = 13.1 W/kg

**Zoom Scan (5x5x7)/Cube 0:** Measurement grid: dx=8mm, dy=8mm, dz=5mm

Reference Value = 83.01 V/m; Power Drift = -0.10 dB

Peak SAR (extrapolated) = 19.0 W/kg

**SAR(1 g) = 6.86 W/kg; SAR(10 g) = 3.93 W/kg**

Maximum value of SAR (measured) = 12.7 W/kg

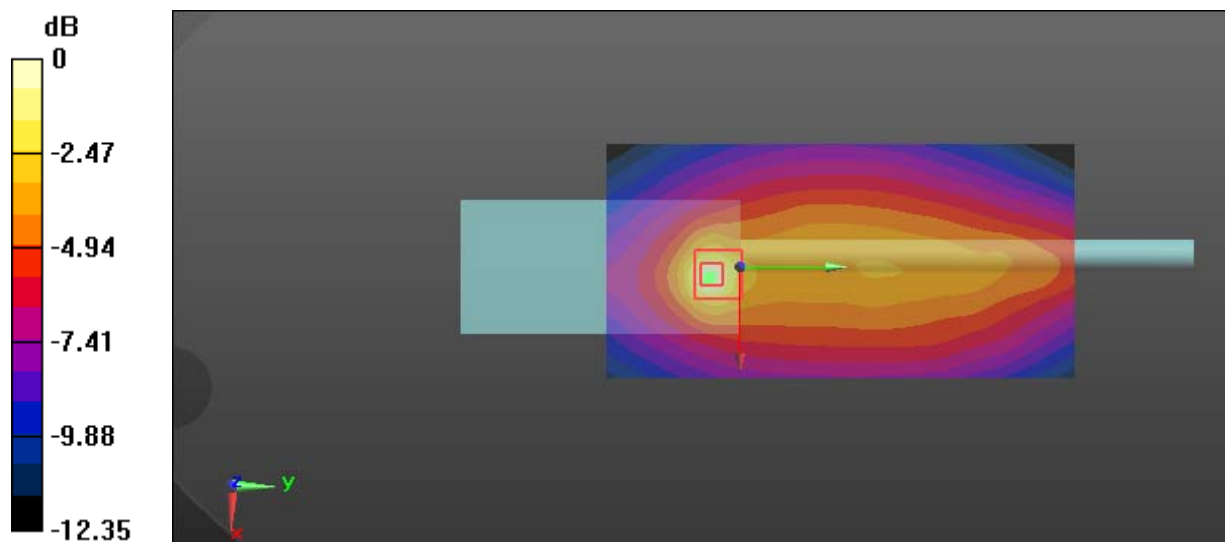

0 dB = 12.7 W/kg = 11.04 dBW/kg

**Test Plot 6#: PTT\_FM 12.5KHz\_Body Back\_146.9875 MHz****DUT: Digital Portable Radio; Type: PD782G VHF; Serial: 17090701320**

Communication System: FM; Frequency: 146.988 MHz; Duty Cycle: 1:1

Medium parameters used:  $f = 146.988$  MHz;  $\sigma = 0.823$  S/m;  $\epsilon_r = 60.776$ ;  $\rho = 1000$  kg/m<sup>3</sup>

Phantom section: Flat Section

DASY5 Configuration:

- Probe: EX3DV4 - SN7441; ConvF(12.58, 12.58, 12.58); Calibrated: 2016/11/15;
- Sensor-Surface: 1.4mm (Mechanical Surface Detection)
- Electronics: DAE4 Sn772; Calibrated: 2016/10/25
- Phantom: ELI v8.0; Type: QDOVA004AA; Serial: 2051
- Measurement SW: DASY52, Version 52.8 (8);

**Area Scan (71x141x1):** Interpolated grid: dx=1.500 mm, dy=1.500 mm

Maximum value of SAR (interpolated) = 10.4 W/kg

**Zoom Scan (5x5x7)/Cube 0:** Measurement grid: dx=8mm, dy=8mm, dz=5mm

Reference Value = 76.32 V/m; Power Drift = -0.20 dB

Peak SAR (extrapolated) = 16.8 W/kg

**SAR(1 g) = 6.15 W/kg; SAR(10 g) = 3.66 W/kg**

Maximum value of SAR (measured) = 11.4 W/kg

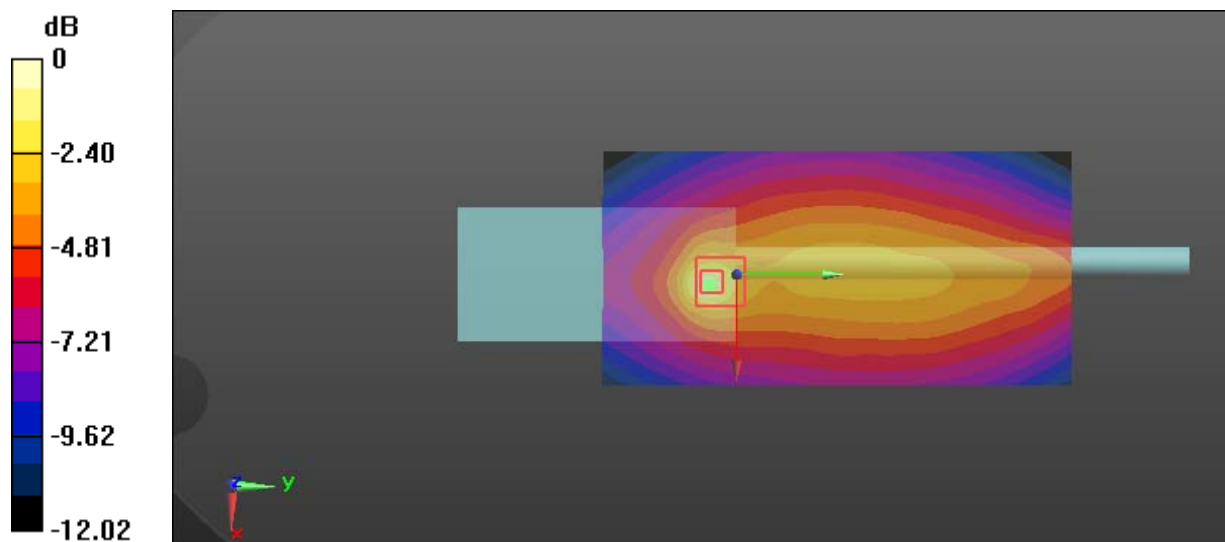

0 dB = 11.4 W/kg = 10.57 dBW/kg

**Test Plot 7#: PTT\_FM 12.5KHz\_Body Back\_147.0125 MHz****DUT: Digital Portable Radio; Type: PD782G VHF; Serial: 17090701320**

Communication System: FM; Frequency: 147.012 MHz; Duty Cycle: 1:1

Medium parameters used:  $f = 147.012$  MHz;  $\sigma = 0.824$  S/m;  $\epsilon_r = 60.772$ ;  $\rho = 1000$  kg/m<sup>3</sup>

Phantom section: Flat Section

DASY5 Configuration:

- Probe: EX3DV4 - SN7441; ConvF(12.58, 12.58, 12.58); Calibrated: 2016/11/15;
- Sensor-Surface: 1.4mm (Mechanical Surface Detection)
- Electronics: DAE4 Sn772; Calibrated: 2016/10/25
- Phantom: ELI v8.0; Type: QDOVA004AA; Serial: 2051
- Measurement SW: DASY52, Version 52.8 (8);

**Area Scan (71x141x1):** Interpolated grid: dx=1.500 mm, dy=1.500 mm

Maximum value of SAR (interpolated) = 16.6 W/kg

**Zoom Scan (5x5x7)/Cube 0:** Measurement grid: dx=8mm, dy=8mm, dz=5mm

Reference Value = 94.06 V/m; Power Drift = -0.13 dB

Peak SAR (extrapolated) = 27.5 W/kg

**SAR(1 g) = 9.42 W/kg; SAR(10 g) = 5.38 W/kg**

Maximum value of SAR (measured) = 17.7 W/kg

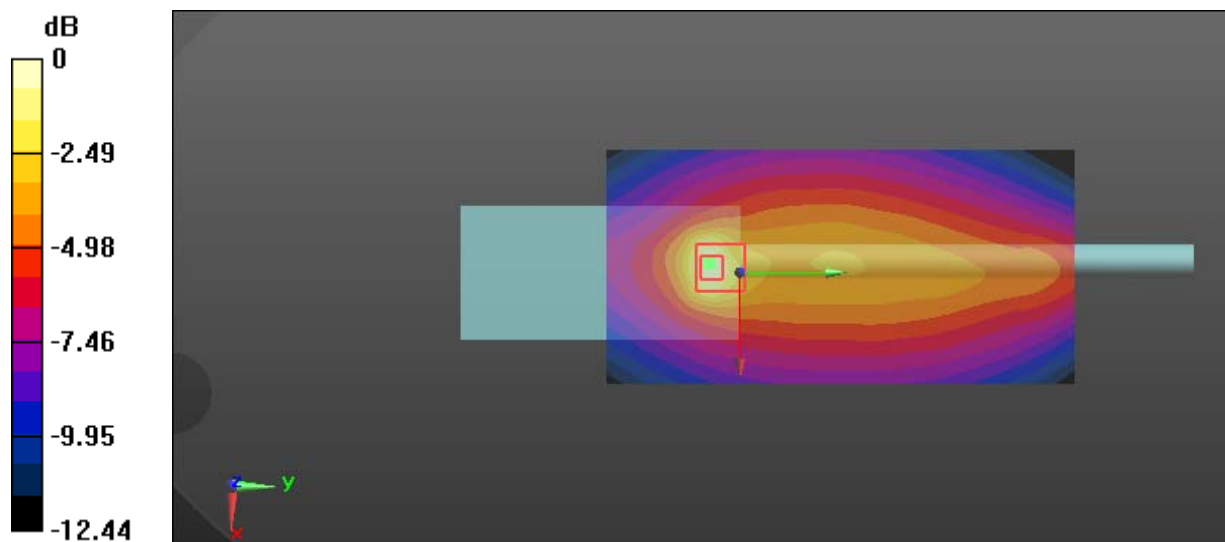

0 dB = 17.7 W/kg = 12.48 dBW/kg

**Test Plot 8#: PTT\_FM 12.5KHz\_Body Back\_153 MHz****DUT: Digital Portable Radio; Type: PD782G VHF; Serial: 17090701320**

Communication System: FM; Frequency: 153 MHz; Duty Cycle: 1:1

Medium parameters used:  $f = 153$  MHz;  $\sigma = 0.831$  S/m;  $\epsilon_r = 60.76$ ;  $\rho = 1000$  kg/m<sup>3</sup>

Phantom section: Flat Section

DASY5 Configuration:

- Probe: EX3DV4 - SN7441; ConvF(12.58, 12.58, 12.58); Calibrated: 2016/11/15;
- Sensor-Surface: 1.4mm (Mechanical Surface Detection)
- Electronics: DAE4 Sn772; Calibrated: 2016/10/25
- Phantom: ELI v8.0; Type: QDOVA004AA; Serial: 2051
- Measurement SW: DASY52, Version 52.8 (8);

**Area Scan (71x141x1):** Interpolated grid: dx=1.500 mm, dy=1.500 mm

Maximum value of SAR (interpolated) = 12.9 W/kg

**Zoom Scan (5x5x7)/Cube 0:** Measurement grid: dx=8mm, dy=8mm, dz=5mm

Reference Value = 80.47 V/m; Power Drift = 0.07 dB

Peak SAR (extrapolated) = 18.9 W/kg

**SAR(1 g) = 7.23 W/kg; SAR(10 g) = 4.32 W/kg**

Maximum value of SAR (measured) = 13.1 W/kg

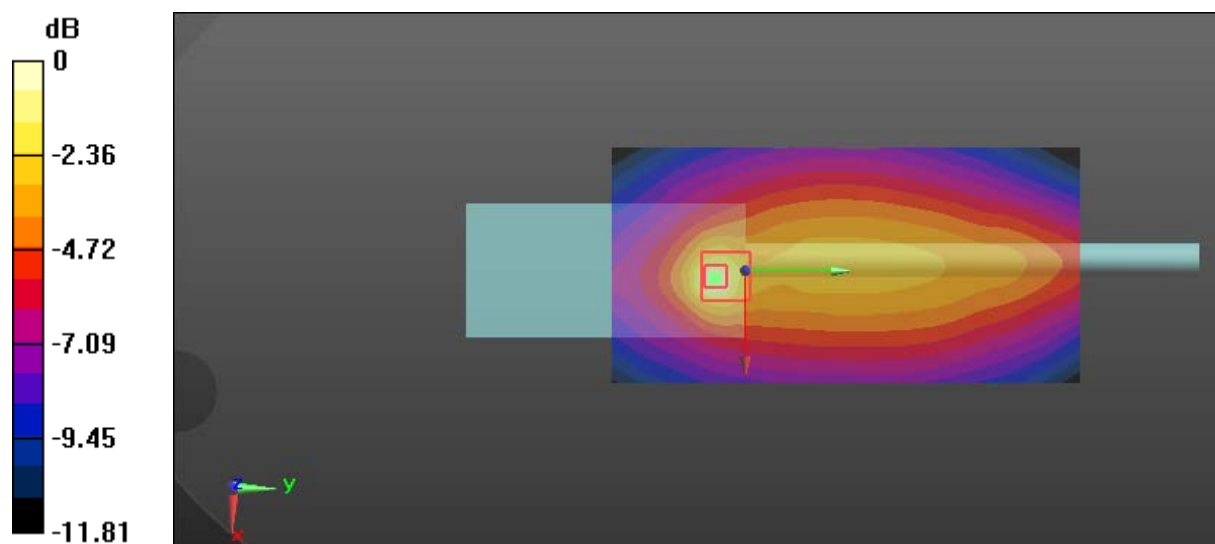

0 dB = 13.1 W/kg = 11.17 dBW/kg



**Test Plot 9#: PTT\_FM 12.5KHz\_Body Back\_159.9875 MHz****DUT: Digital Portable Radio; Type: PD782G VHF; Serial: 17090701320**

Communication System: FM; Frequency: 159.988 MHz; Duty Cycle: 1:1

Medium parameters used:  $f = 159.988$  MHz;  $\sigma = 0.834$  S/m;  $\epsilon_r = 60.752$ ;  $\rho = 1000$  kg/m<sup>3</sup>

Phantom section: Flat Section

DASY5 Configuration:

- Probe: EX3DV4 - SN7441; ConvF(12.58, 12.58, 12.58); Calibrated: 2016/11/15;
- Sensor-Surface: 1.4mm (Mechanical Surface Detection)
- Electronics: DAE4 Sn772; Calibrated: 2016/10/25
- Phantom: ELI v8.0; Type: QDOVA004AA; Serial: 2051
- Measurement SW: DASY52, Version 52.8 (8);

**Area Scan (71x141x1):** Interpolated grid: dx=1.500 mm, dy=1.500 mm

Maximum value of SAR (interpolated) = 9.07 W/kg

**Zoom Scan (5x5x7)/Cube 0:** Measurement grid: dx=8mm, dy=8mm, dz=5mm

Reference Value = 78.98 V/m; Power Drift = 0.03 dB

Peak SAR (extrapolated) = 15.9 W/kg

**SAR(1 g) = 6.32 W/kg; SAR(10 g) = 3.91 W/kg**

Maximum value of SAR (measured) = 11.2 W/kg

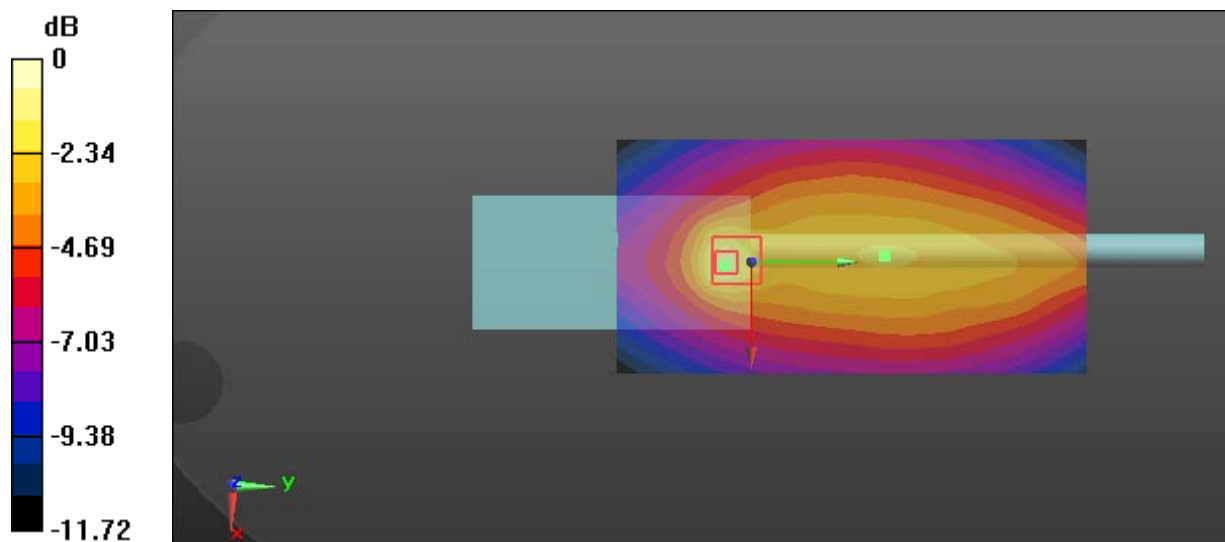

0 dB = 11.2 W/kg = 10.49 dBW/kg

**Test Plot 10#: PTT\_FM 12.5KHz\_Body Back\_160.0125 MHz****DUT: Digital Portable Radio; Type: PD782G VHF; Serial: 17090701320**

Communication System: FM; Frequency: 160.012 MHz; Duty Cycle: 1:1

Medium parameters used:  $f = 160.012$  MHz;  $\sigma = 0.835$  S/m;  $\epsilon_r = 60.747$ ;  $\rho = 1000$  kg/m<sup>3</sup>

Phantom section: Flat Section

DASY5 Configuration:

- Probe: EX3DV4 - SN7441; ConvF(12.58, 12.58, 12.58); Calibrated: 2016/11/15;
- Sensor-Surface: 1.4mm (Mechanical Surface Detection)
- Electronics: DAE4 Sn772; Calibrated: 2016/10/25
- Phantom: ELI v8.0; Type: QDOVA004AA; Serial: 2051
- Measurement SW: DASY52, Version 52.8 (8);

**Area Scan (71x141x1):** Interpolated grid: dx=1.500 mm, dy=1.500 mm

Maximum value of SAR (interpolated) = 17.2 W/kg

**Zoom Scan (5x5x7)/Cube 0:** Measurement grid: dx=8mm, dy=8mm, dz=5mm

Reference Value = 98.91 V/m; Power Drift = -0.18 dB

Peak SAR (extrapolated) = 24.3 W/kg

**SAR(1 g) = 9.76 W/kg; SAR(10 g) = 5.93 W/kg**

Maximum value of SAR (measured) = 16.9 W/kg

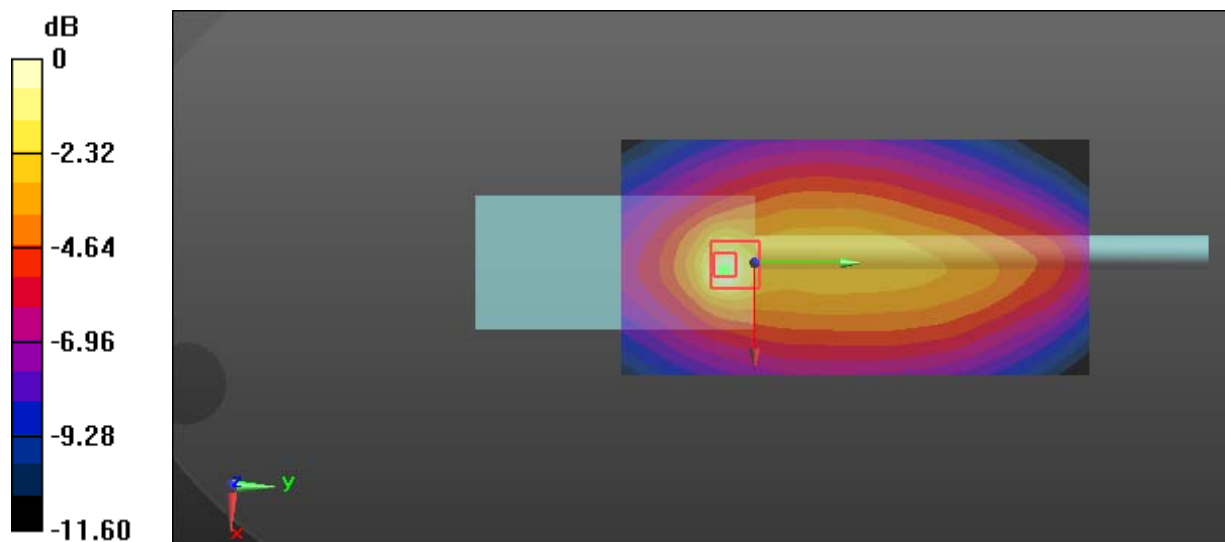

0 dB = 16.9 W/kg = 12.28 dBW/kg

**Test Plot 11#: PTT\_FM 12.5KHz\_Body Back\_167 MHz****DUT: Digital Portable Radio; Type: PD782G VHF; Serial: 17090701320**

Communication System: FM; Frequency: 167 MHz; Duty Cycle: 1:1

Medium parameters used:  $f = 167$  MHz;  $\sigma = 0.837$  S/m;  $\epsilon_r = 60.729$ ;  $\rho = 1000$  kg/m<sup>3</sup>

Phantom section: Flat Section

DASY5 Configuration:

- Probe: EX3DV4 - SN7441; ConvF(12.58, 12.58, 12.58); Calibrated: 2016/11/15;
- Sensor-Surface: 1.4mm (Mechanical Surface Detection)
- Electronics: DAE4 Sn772; Calibrated: 2016/10/25
- Phantom: ELI v8.0; Type: QDOVA004AA; Serial: 2051
- Measurement SW: DASY52, Version 52.8 (8);

**Area Scan (71x141x1):** Interpolated grid: dx=1.500 mm, dy=1.500 mm

Maximum value of SAR (interpolated) = 12.6 W/kg

**Zoom Scan (5x5x7)/Cube 0:** Measurement grid: dx=8mm, dy=8mm, dz=5mm

Reference Value = 86.94 V/m; Power Drift = -0.06 dB

Peak SAR (extrapolated) = 18.3 W/kg

**SAR(1 g) = 7.78 W/kg; SAR(10 g) = 4.93 W/kg**

Maximum value of SAR (measured) = 13.1 W/kg

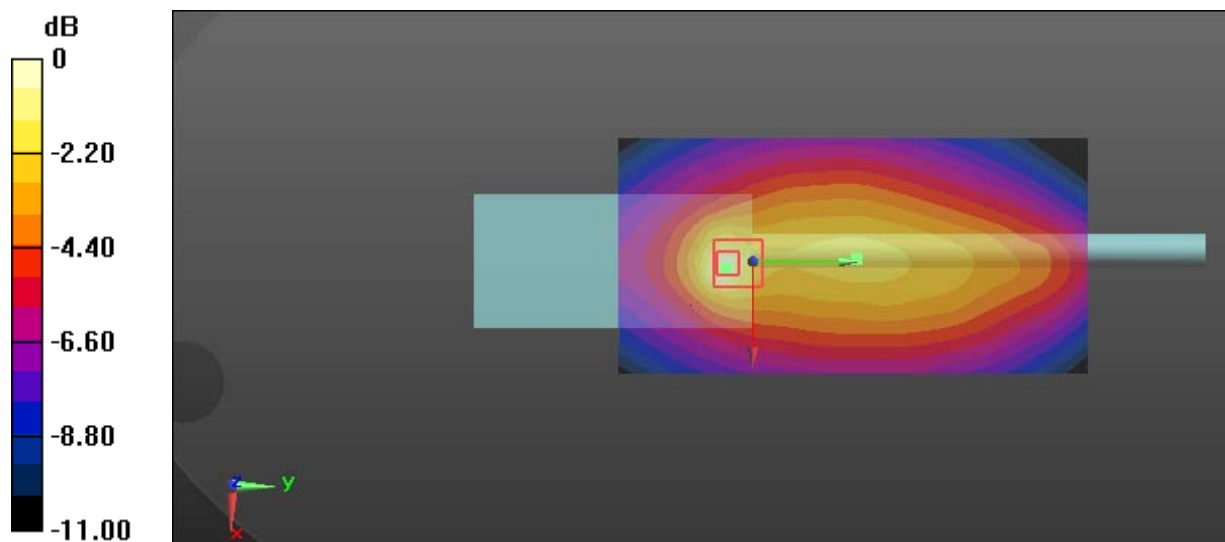

0 dB = 13.1 W/kg = 11.17 dBW/kg

**Test Plot 12#: PTT\_FM 12.5KHz\_Body Back\_173.9875 MHz****DUT: Digital Portable Radio; Type: PD782G VHF; Serial: 17090701320**

Communication System: FM; Frequency: 173.988 MHz; Duty Cycle: 1:1

Medium parameters used:  $f = 173.988$  MHz;  $\sigma = 0.838$  S/m;  $\epsilon_r = 60.713$ ;  $\rho = 1000$  kg/m<sup>3</sup>

Phantom section: Flat Section

DASY5 Configuration:

- Probe: EX3DV4 - SN7441; ConvF(12.58, 12.58, 12.58); Calibrated: 2016/11/15;
- Sensor-Surface: 1.4mm (Mechanical Surface Detection)
- Electronics: DAE4 Sn772; Calibrated: 2016/10/25
- Phantom: ELI v8.0; Type: QDOVA004AA; Serial: 2051
- Measurement SW: DASY52, Version 52.8 (8);

**Area Scan (71x141x1):** Interpolated grid: dx=1.500 mm, dy=1.500 mm

Maximum value of SAR (interpolated) = 10 W/kg

**Zoom Scan (5x5x7)/Cube 0:** Measurement grid: dx=8mm, dy=8mm, dz=5mm

Reference Value = 82.48 V/m; Power Drift = -0.13 dB

Peak SAR (extrapolated) = 13.7 W/kg

**SAR(1 g) = 6.17 W/kg; SAR(10 g) = 4.11 W/kg**

Maximum value of SAR (measured) = 10.1 W/kg

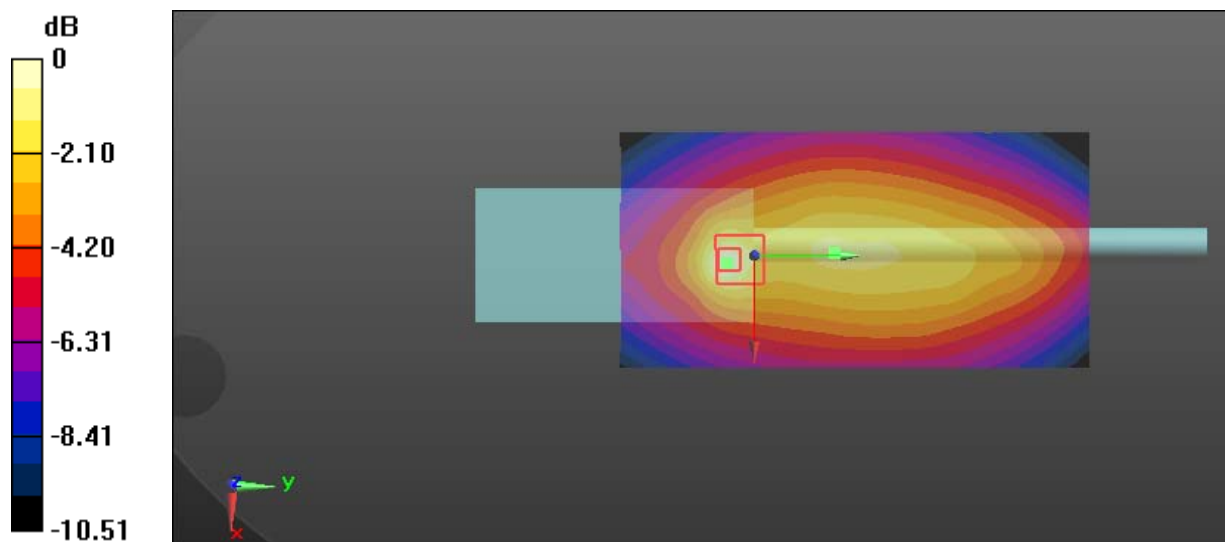

0 dB = 10.1 W/kg = 10.04 dBW/kg

**Test Plot 13#: PTT\_FM 25KHz\_Face Up\_136.0125 MHz****DUT: Digital Portable Radio; Type: PD782G VHF; Serial: 17090701320**

Communication System: FM; Frequency: 136.012 MHz; Duty Cycle: 1:1

Medium parameters used:  $f = 136.012$  MHz;  $\sigma = 0.771$  S/m;  $\epsilon_r = 53.208$ ;  $\rho = 1000$  kg/m<sup>3</sup>

Phantom section: Flat Section

DASY5 Configuration:

- Probe: EX3DV4 - SN7441; ConvF(13.25, 13.25, 13.25); Calibrated: 2016/11/15;
- Sensor-Surface: 1.4mm (Mechanical Surface Detection)
- Electronics: DAE4 Sn772; Calibrated: 2016/10/25
- Phantom: ELI v8.0; Type: QDOVA004AA; Serial: 2051
- Measurement SW: DASY52, Version 52.8 (8);

**Area Scan (71x141x1):** Interpolated grid: dx=1.500 mm, dy=1.500 mm

Maximum value of SAR (interpolated) = 4.55 W/kg

**Zoom Scan (5x5x7)/Cube 0:** Measurement grid: dx=8mm, dy=8mm, dz=5mm

Reference Value = 63.38 V/m; Power Drift = -0.01 dB

Peak SAR (extrapolated) = 5.47 W/kg

**SAR(1 g) = 3.34 W/kg; SAR(10 g) = 2.51 W/kg**

Maximum value of SAR (measured) = 4.48 W/kg

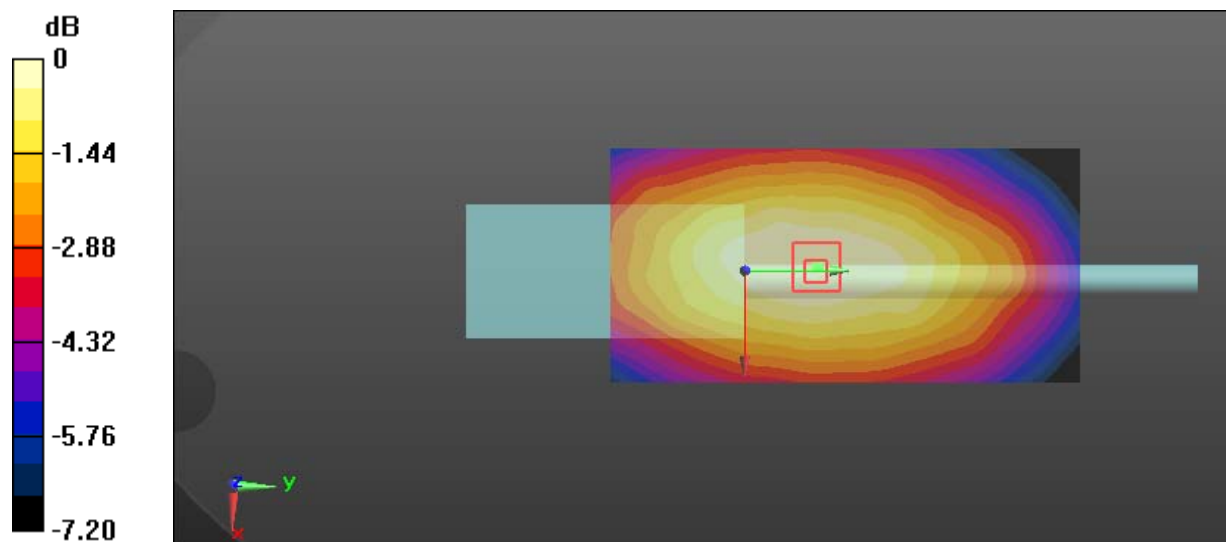

0 dB = 4.48 W/kg = 6.51 dBW/kg

**Test Plot 14#: PTT\_FM 25KHz\_Face Up\_147.0125 MHz****DUT: Digital Portable Radio; Type: PD782G VHF; Serial: 17090701320**

Communication System: FM; Frequency: 147.012 MHz; Duty Cycle: 1:1

Medium parameters used:  $f = 147.012$  MHz;  $\sigma = 0.782$  S/m;  $\epsilon_r = 53.179$ ;  $\rho = 1000$  kg/m<sup>3</sup>

Phantom section: Flat Section

DASY5 Configuration:

- Probe: EX3DV4 - SN7441; ConvF(13.25, 13.25, 13.25); Calibrated: 2016/11/15;
- Sensor-Surface: 1.4mm (Mechanical Surface Detection)
- Electronics: DAE4 Sn772; Calibrated: 2016/10/25
- Phantom: ELI v8.0; Type: QDOVA004AA; Serial: 2051
- Measurement SW: DASY52, Version 52.8 (8);

**Area Scan (71x141x1):** Interpolated grid: dx=1.500 mm, dy=1.500 mm

Maximum value of SAR (interpolated) = 4.32 W/kg

**Zoom Scan (5x5x7)/Cube 0:** Measurement grid: dx=8mm, dy=8mm, dz=5mm

Reference Value = 58.87 V/m; Power Drift = 0.07 dB

Peak SAR (extrapolated) = 5.30 W/kg

**SAR(1 g) = 3.21 W/kg; SAR(10 g) = 2.42 W/kg**

Maximum value of SAR (measured) = 4.36 W/kg

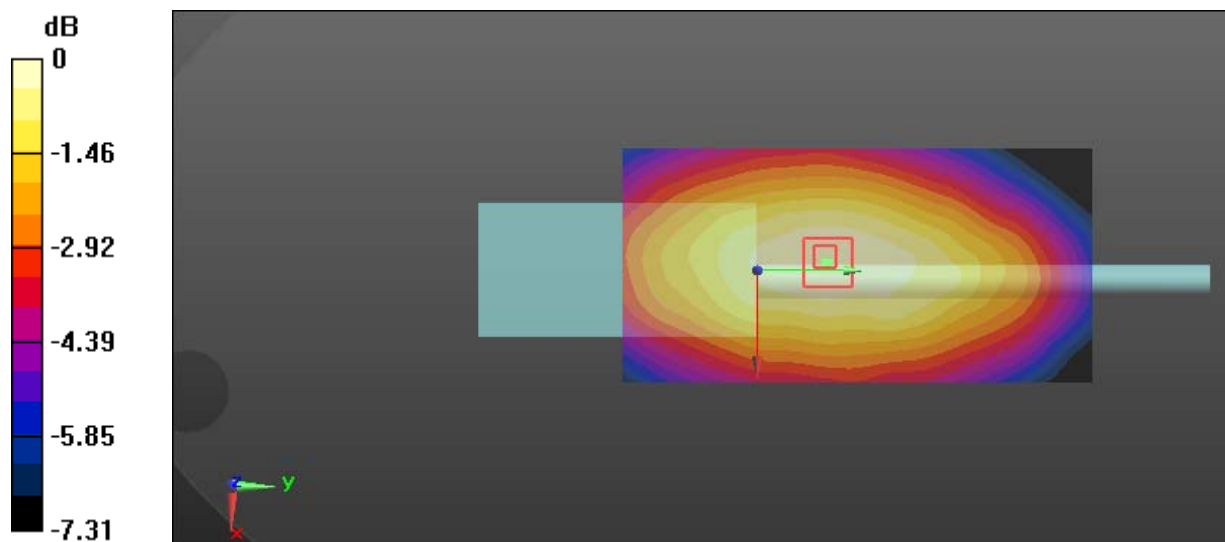

0 dB = 4.36 W/kg = 6.39 dBW/kg

**Test Plot 15#: PTT\_FM 12.5KHz\_Face Up\_160.0125 MHz****DUT: Digital Portable Radio; Type: PD782G VHF; Serial: 17090701320**

Communication System: FM; Frequency: 160.012 MHz; Duty Cycle: 1:1

Medium parameters used:  $f = 160.012$  MHz;  $\sigma = 0.792$  S/m;  $\epsilon_r = 52.977$ ;  $\rho = 1000$  kg/m<sup>3</sup>

Phantom section: Flat Section

DASY5 Configuration:

- Probe: EX3DV4 - SN7441; ConvF(13.25, 13.25, 13.25); Calibrated: 2016/11/15;
- Sensor-Surface: 1.4mm (Mechanical Surface Detection)
- Electronics: DAE4 Sn772; Calibrated: 2016/10/25
- Phantom: ELI v8.0; Type: QDOVA004AA; Serial: 2051
- Measurement SW: DASY52, Version 52.8 (8);

**Area Scan (71x141x1):** Interpolated grid: dx=1.500 mm, dy=1.500 mm

Maximum value of SAR (interpolated) = 4.31 W/kg

**Zoom Scan (5x5x7)/Cube 0:** Measurement grid: dx=8mm, dy=8mm, dz=5mm

Reference Value = 61.55 V/m; Power Drift = 0.05 dB

Peak SAR (extrapolated) = 4.99 W/kg

**SAR(1 g) = 3.15 W/kg; SAR(10 g) = 2.39 W/kg**

Maximum value of SAR (measured) = 4.18 W/kg

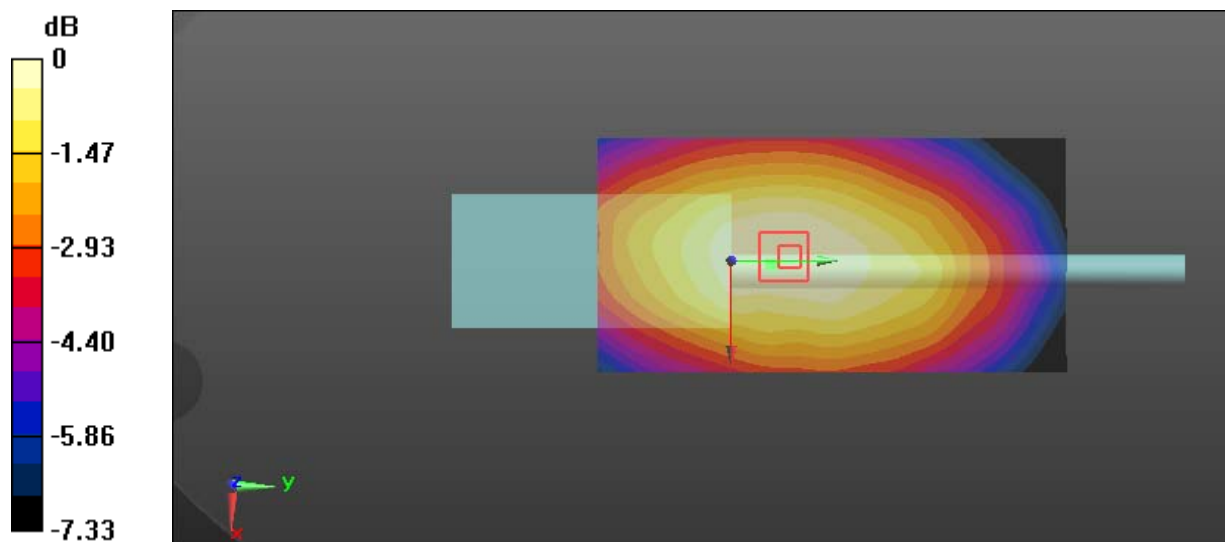

0 dB = 4.18 W/kg = 6.21 dBW/kg

**Test Plot 16#: PTT\_FM 25KHz\_Body Back\_136.0125 MHz****DUT: Digital Portable Radio; Type: PD782G VHF; Serial: 17090701320**

Communication System: FM; Frequency: 136.012 MHz; Duty Cycle: 1:1

Medium parameters used:  $f = 136.012$  MHz;  $\sigma = 0.817$  S/m;  $\epsilon_r = 60.796$ ;  $\rho = 1000$  kg/m<sup>3</sup>

Phantom section: Flat Section

DASY5 Configuration:

- Probe: EX3DV4 - SN7441; ConvF(12.58, 12.58, 12.58); Calibrated: 2016/11/15;
- Sensor-Surface: 1.4mm (Mechanical Surface Detection)
- Electronics: DAE4 Sn772; Calibrated: 2016/10/25
- Phantom: ELI v8.0; Type: QDOVA004AA; Serial: 2051
- Measurement SW: DASY52, Version 52.8 (8);

**Area Scan (71x141x1):** Interpolated grid: dx=1.500 mm, dy=1.500 mm

Maximum value of SAR (interpolated) = 17.0 W/kg

**Zoom Scan (5x5x7)/Cube 0:** Measurement grid: dx=8mm, dy=8mm, dz=5mm

Reference Value = 96.71 V/m; Power Drift = -0.15 dB

Peak SAR (extrapolated) = 26.5 W/kg

**SAR(1 g) = 9.51 W/kg; SAR(10 g) = 5.42 W/kg**

Maximum value of SAR (measured) = 17.5 W/kg

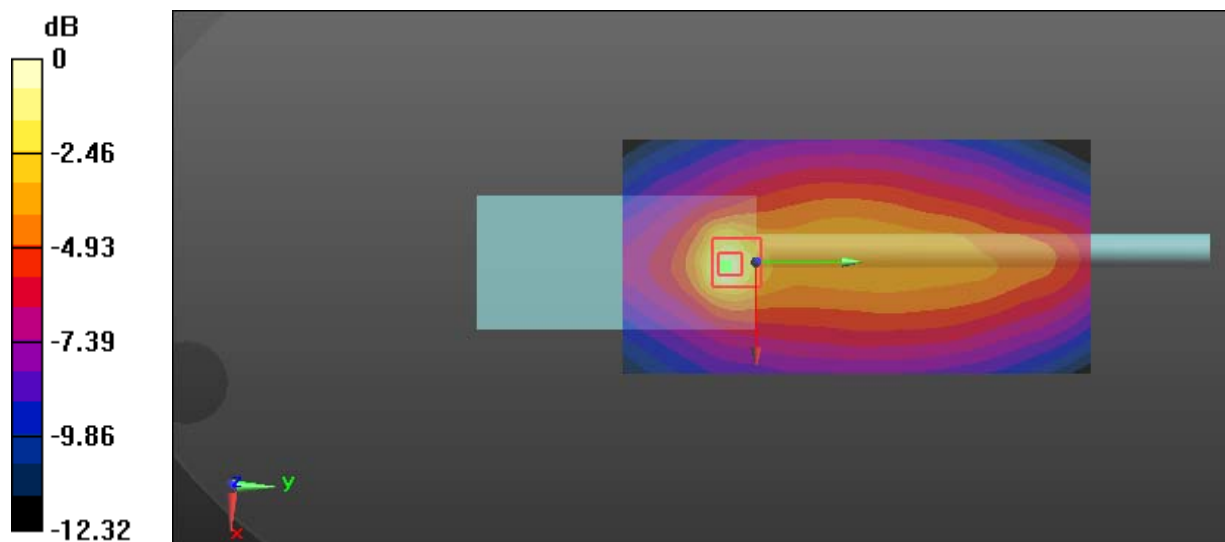

0 dB = 17.5 W/kg = 12.43 dBW/kg



**Test Plot 17#: PTT\_FM 25KHz\_Body Back\_141 MHz****DUT: Digital Portable Radio; Type: PD782G VHF; Serial: 17090701320**

Communication System: FM; Frequency: 141 MHz; Duty Cycle: 1:1

Medium parameters used:  $f = 141$  MHz;  $\sigma = 0.819$  S/m;  $\epsilon_r = 60.781$ ;  $\rho = 1000$  kg/m<sup>3</sup>

Phantom section: Flat Section

DASY5 Configuration:

- Probe: EX3DV4 - SN7441; ConvF(12.58, 12.58, 12.58); Calibrated: 2016/11/15;
- Sensor-Surface: 1.4mm (Mechanical Surface Detection)
- Electronics: DAE4 Sn772; Calibrated: 2016/10/25
- Phantom: ELI v8.0; Type: QDOVA004AA; Serial: 2051
- Measurement SW: DASY52, Version 52.8 (8);

**Area Scan (71x141x1):** Interpolated grid: dx=1.500 mm, dy=1.500 mm

Maximum value of SAR (interpolated) = 14.8 W/kg

**Zoom Scan (5x5x7)/Cube 0:** Measurement grid: dx=8mm, dy=8mm, dz=5mm

Reference Value = 76.16 V/m; Power Drift = -0.14 dB

Peak SAR (extrapolated) = 23.2 W/kg

**SAR(1 g) = 7.66 W/kg; SAR(10 g) = 4.15 W/kg**

Maximum value of SAR (measured) = 15.1 W/kg

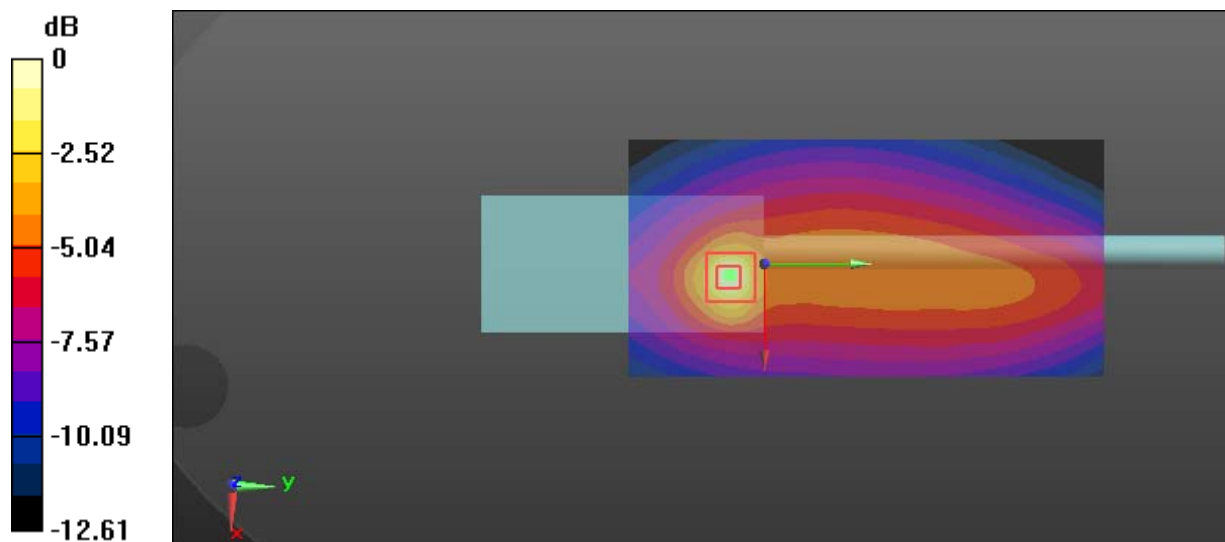

0 dB = 15.1 W/kg = 11.79 dBW/kg

**Test Plot 18#: PTT\_FM 25KHz\_Body Back\_146.9875 MHz****DUT: Digital Portable Radio; Type: PD782G VHF; Serial: 17090701320**

Communication System: FM; Frequency: 146.988 MHz; Duty Cycle: 1:1

Medium parameters used:  $f = 146.988$  MHz;  $\sigma = 0.823$  S/m;  $\epsilon_r = 60.776$ ;  $\rho = 1000$  kg/m<sup>3</sup>

Phantom section: Flat Section

DASY5 Configuration:

- Probe: EX3DV4 - SN7441; ConvF(12.58, 12.58, 12.58); Calibrated: 2016/11/15;
- Sensor-Surface: 1.4mm (Mechanical Surface Detection)
- Electronics: DAE4 Sn772; Calibrated: 2016/10/25
- Phantom: ELI v8.0; Type: QDOVA004AA; Serial: 2051
- Measurement SW: DASY52, Version 52.8 (8);

**Area Scan (71x141x1):** Interpolated grid: dx=1.500 mm, dy=1.500 mm

Maximum value of SAR (interpolated) = 11.1 W/kg

**Zoom Scan (5x5x7)/Cube 0:** Measurement grid: dx=8mm, dy=8mm, dz=5mm

Reference Value = 74.83 V/m; Power Drift = -0.17 dB

Peak SAR (extrapolated) = 18.5 W/kg

**SAR(1 g) = 6.57 W/kg; SAR(10 g) = 3.81 W/kg**

Maximum value of SAR (measured) = 12.0 W/kg

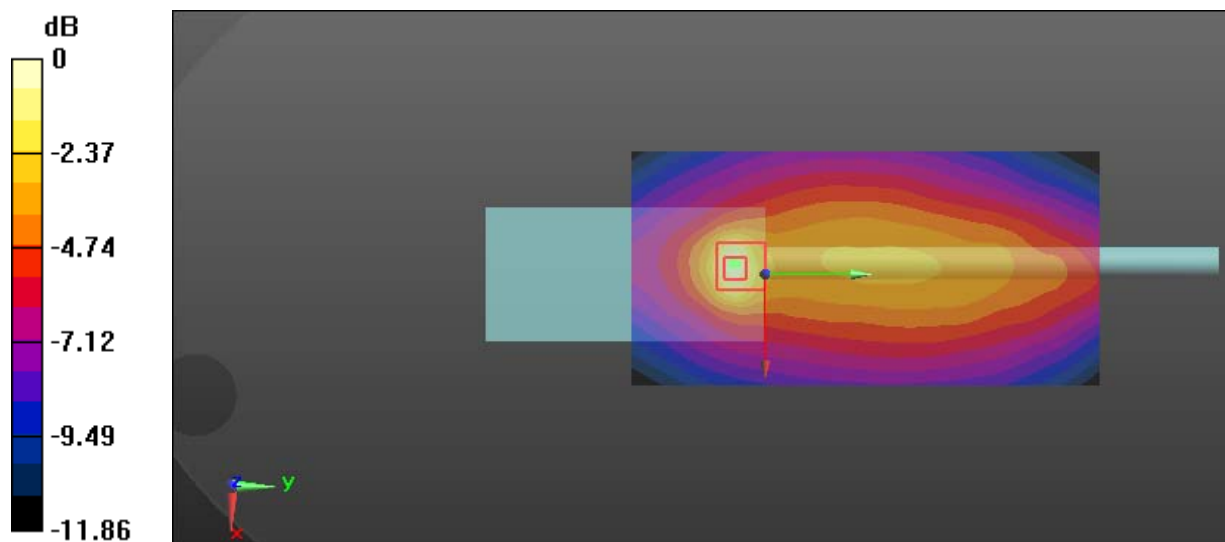

0 dB = 12.0 W/kg = 10.79 dBW/kg

**Test Plot 19#: PTT\_FM 25KHz\_Body Back\_147.0125 MHz****DUT: Digital Portable Radio; Type: PD782G VHF; Serial: 17090701320**

Communication System: FM; Frequency: 147.012 MHz; Duty Cycle: 1:1

Medium parameters used:  $f = 147.012$  MHz;  $\sigma = 0.824$  S/m;  $\epsilon_r = 60.772$ ;  $\rho = 1000$  kg/m<sup>3</sup>

Phantom section: Flat Section

DASY5 Configuration:

- Probe: EX3DV4 - SN7441; ConvF(12.58, 12.58, 12.58); Calibrated: 2016/11/15;
- Sensor-Surface: 1.4mm (Mechanical Surface Detection)
- Electronics: DAE4 Sn772; Calibrated: 2016/10/25
- Phantom: ELI v8.0; Type: QDOVA004AA; Serial: 2051
- Measurement SW: DASY52, Version 52.8 (8);

**Area Scan (71x141x1):** Interpolated grid: dx=1.500 mm, dy=1.500 mm

Maximum value of SAR (interpolated) = 16.0 W/kg

**Zoom Scan (5x5x7)/Cube 0:** Measurement grid: dx=8mm, dy=8mm, dz=5mm

Reference Value = 94.47 V/m; Power Drift = -0.02 dB

Peak SAR (extrapolated) = 25.4 W/kg

**SAR(1 g) = 9.16 W/kg; SAR(10 g) = 5.28 W/kg**

Maximum value of SAR (measured) = 16.7 W/kg

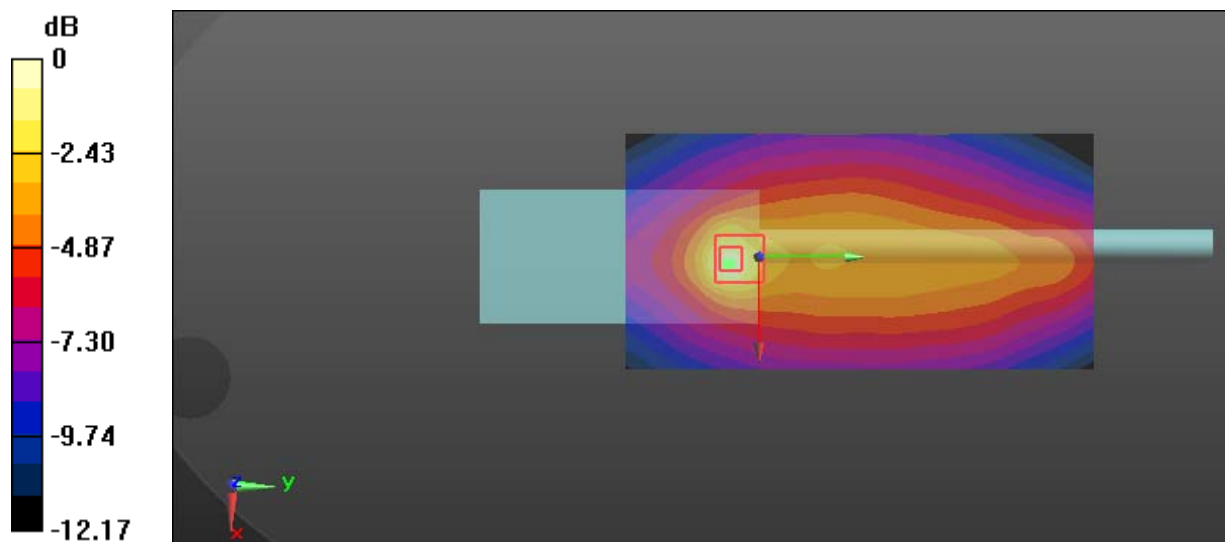

0 dB = 16.7 W/kg = 12.23 dBW/kg

**Test Plot 20#: PTT\_FM 25KHz\_Body Back\_153 MHz****DUT: Digital Portable Radio; Type: PD782G VHF; Serial: 17090701320**

Communication System: FM; Frequency: 153 MHz; Duty Cycle: 1:1

Medium parameters used:  $f = 153$  MHz;  $\sigma = 0.831$  S/m;  $\epsilon_r = 60.76$ ;  $\rho = 1000$  kg/m<sup>3</sup>

Phantom section: Flat Section

DASY5 Configuration:

- Probe: EX3DV4 - SN7441; ConvF(12.58, 12.58, 12.58); Calibrated: 2016/11/15;
- Sensor-Surface: 1.4mm (Mechanical Surface Detection)
- Electronics: DAE4 Sn772; Calibrated: 2016/10/25
- Phantom: ELI v8.0; Type: QDOVA004AA; Serial: 2051
- Measurement SW: DASY52, Version 52.8 (8);

**Area Scan (71x141x1):** Interpolated grid: dx=1.500 mm, dy=1.500 mm

Maximum value of SAR (interpolated) = 13.1 W/kg

**Zoom Scan (5x5x7)/Cube 0:** Measurement grid: dx=8mm, dy=8mm, dz=5mm

Reference Value = 80.59 V/m; Power Drift = -0.04 dB

Peak SAR (extrapolated) = 20.1 W/kg

**SAR(1 g) = 7.46 W/kg; SAR(10 g) = 4.36 W/kg**

Maximum value of SAR (measured) = 13.4 W/kg

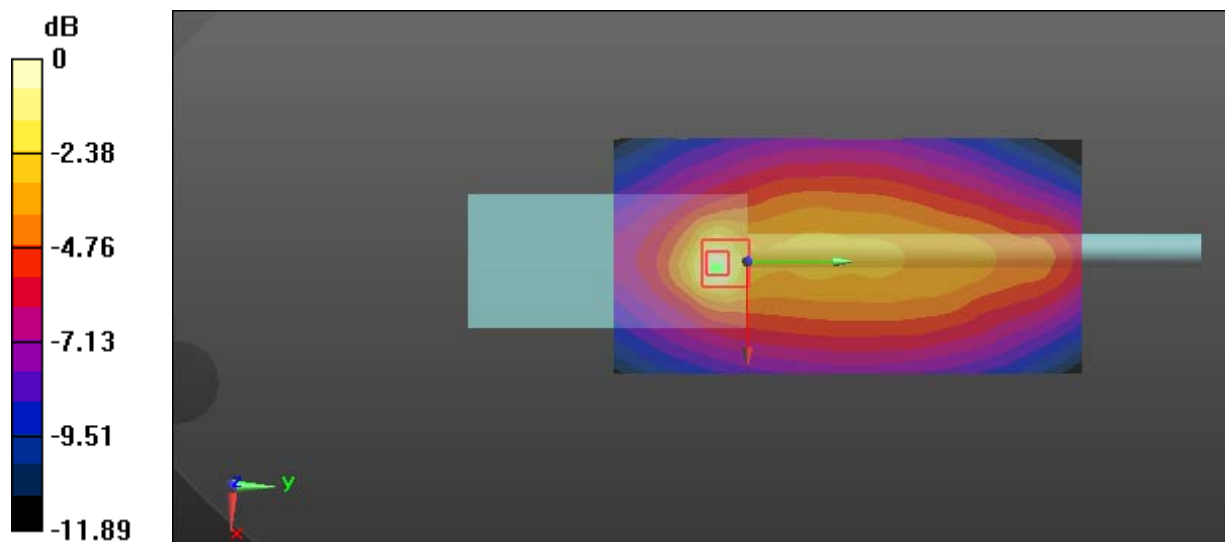

0 dB = 13.4 W/kg = 11.27 dBW/kg

**Test Plot 21#: PTT\_FM 25KHz\_Body Back\_159.9875 MHz****DUT: Digital Portable Radio; Type: PD782G VHF; Serial: 17090701320**

Communication System: FM; Frequency: 159.988 MHz; Duty Cycle: 1:1

Medium parameters used:  $f = 159.988$  MHz;  $\sigma = 0.834$  S/m;  $\epsilon_r = 60.752$ ;  $\rho = 1000$  kg/m<sup>3</sup>

Phantom section: Flat Section

DASY5 Configuration:

- Probe: EX3DV4 - SN7441; ConvF(12.58, 12.58, 12.58); Calibrated: 2016/11/15;
- Sensor-Surface: 1.4mm (Mechanical Surface Detection)
- Electronics: DAE4 Sn772; Calibrated: 2016/10/25
- Phantom: ELI v8.0; Type: QDOVA004AA; Serial: 2051
- Measurement SW: DASY52, Version 52.8 (8);

**Area Scan (71x141x1):** Interpolated grid: dx=1.500 mm, dy=1.500 mm

Maximum value of SAR (interpolated) = 9.28 W/kg

**Zoom Scan (5x5x7)/Cube 0:** Measurement grid: dx=8mm, dy=8mm, dz=5mm

Reference Value = 74.03 V/m; Power Drift = -0.00 dB

Peak SAR (extrapolated) = 18.1 W/kg

**SAR(1 g) = 6.12 W/kg; SAR(10 g) = 3.62 W/kg**

Maximum value of SAR (measured) = 11.8 W/kg

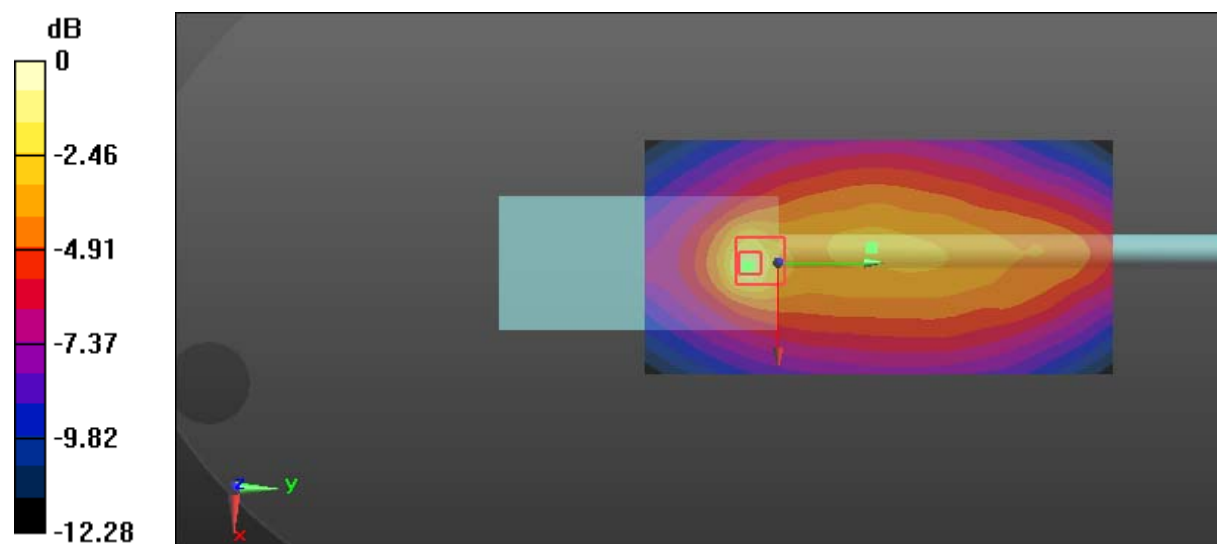

0 dB = 11.8 W/kg = 10.72 dBW/kg

**Test Plot 22#: PTT\_FM 25KHz\_Body Back\_160.0125 MHz****DUT: Digital Portable Radio; Type: PD782G VHF; Serial: 17090701320**

Communication System: FM; Frequency: 160.012 MHz; Duty Cycle: 1:1

Medium parameters used:  $f = 160.012$  MHz;  $\sigma = 0.835$  S/m;  $\epsilon_r = 60.747$ ;  $\rho = 1000$  kg/m<sup>3</sup>

Phantom section: Flat Section

DASY5 Configuration:

- Probe: EX3DV4 - SN7441; ConvF(12.58, 12.58, 12.58); Calibrated: 2016/11/15;
- Sensor-Surface: 1.4mm (Mechanical Surface Detection)
- Electronics: DAE4 Sn772; Calibrated: 2016/10/25
- Phantom: ELI v8.0; Type: QDOVA004AA; Serial: 2051
- Measurement SW: DASY52, Version 52.8 (8);

**Area Scan (71x141x1):** Interpolated grid: dx=1.500 mm, dy=1.500 mm

Maximum value of SAR (interpolated) = 17.0 W/kg

**Zoom Scan (5x5x7)/Cube 0:** Measurement grid: dx=8mm, dy=8mm, dz=5mm

Reference Value = 104.2 V/m; Power Drift = -0.14 dB

Peak SAR (extrapolated) = 28.0 W/kg

**SAR(1 g) = 10.4 W/kg; SAR(10 g) = 6.2 W/kg**

Maximum value of SAR (measured) = 18.9 W/kg

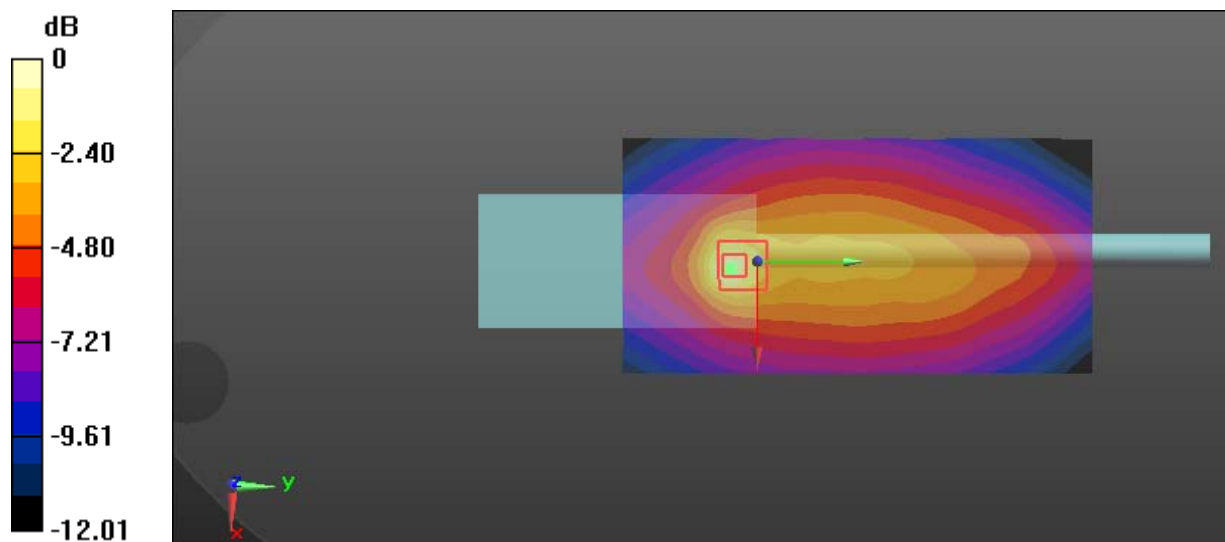

0 dB = 18.9 W/kg = 12.76 dBW/kg

**Test Plot 23#: PTT\_FM 25KHz\_Body Back\_167 MHz****DUT: Digital Portable Radio; Type: PD782G VHF; Serial: 17090701320**

Communication System: FM; Frequency: 167 MHz; Duty Cycle: 1:1

Medium parameters used:  $f = 167$  MHz;  $\sigma = 0.837$  S/m;  $\epsilon_r = 60.729$ ;  $\rho = 1000$  kg/m<sup>3</sup>

Phantom section: Flat Section

DASY5 Configuration:

- Probe: EX3DV4 - SN7441; ConvF(12.58, 12.58, 12.58); Calibrated: 2016/11/15;
- Sensor-Surface: 1.4mm (Mechanical Surface Detection)
- Electronics: DAE4 Sn772; Calibrated: 2016/10/25
- Phantom: ELI v8.0; Type: QDOVA004AA; Serial: 2051
- Measurement SW: DASY52, Version 52.8 (8);

**Area Scan (71x141x1):** Interpolated grid: dx=1.500 mm, dy=1.500 mm

Maximum value of SAR (interpolated) = 15.2 W/kg

**Zoom Scan (5x5x7)/Cube 0:** Measurement grid: dx=8mm, dy=8mm, dz=5mm

Reference Value = 87.70 V/m; Power Drift = -0.04 dB

Peak SAR (extrapolated) = 22.1 W/kg

**SAR(1 g) = 8.32 W/kg; SAR(10 g) = 5.06 W/kg**

Maximum value of SAR (measured) = 15.0 W/kg

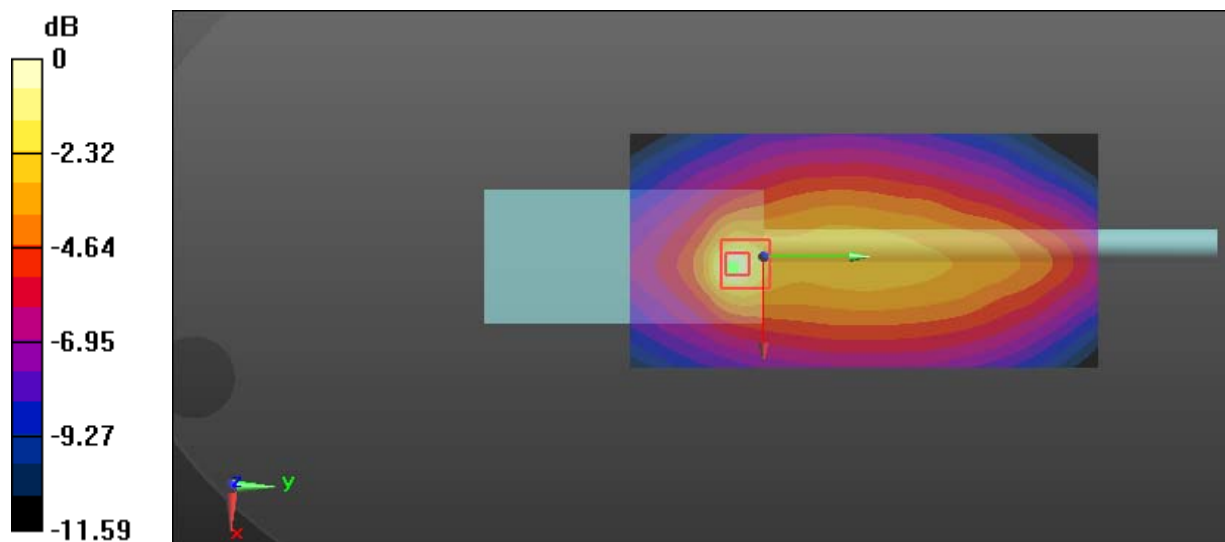

**Test Plot 24#: PTT\_FM 25KHz\_Body Back\_173.9875 MHz****DUT: Digital Portable Radio; Type: PD782G VHF; Serial: 17090701320**

Communication System: FM; Frequency: 173.988 MHz; Duty Cycle: 1:1

Medium parameters used:  $f = 173.988$  MHz;  $\sigma = 0.838$  S/m;  $\epsilon_r = 60.713$ ;  $\rho = 1000$  kg/m<sup>3</sup>

Phantom section: Flat Section

DASY5 Configuration:

- Probe: EX3DV4 - SN7441; ConvF(12.58, 12.58, 12.58); Calibrated: 2016/11/15;
- Sensor-Surface: 1.4mm (Mechanical Surface Detection)
- Electronics: DAE4 Sn772; Calibrated: 2016/10/25
- Phantom: ELI v8.0; Type: QDOVA004AA; Serial: 2051
- Measurement SW: DASY52, Version 52.8 (8);

**Area Scan (71x141x1):** Interpolated grid: dx=1.500 mm, dy=1.500 mm

Maximum value of SAR (interpolated) = 10.3 W/kg

**Zoom Scan (5x5x7)/Cube 0:** Measurement grid: dx=8mm, dy=8mm, dz=5mm

Reference Value = 83.88 V/m; Power Drift = -0.17 dB

Peak SAR (extrapolated) = 16.2 W/kg

**SAR(1 g) = 6.52 W/kg; SAR(10 g) = 4.15 W/kg**

Maximum value of SAR (measured) = 11.3 W/kg

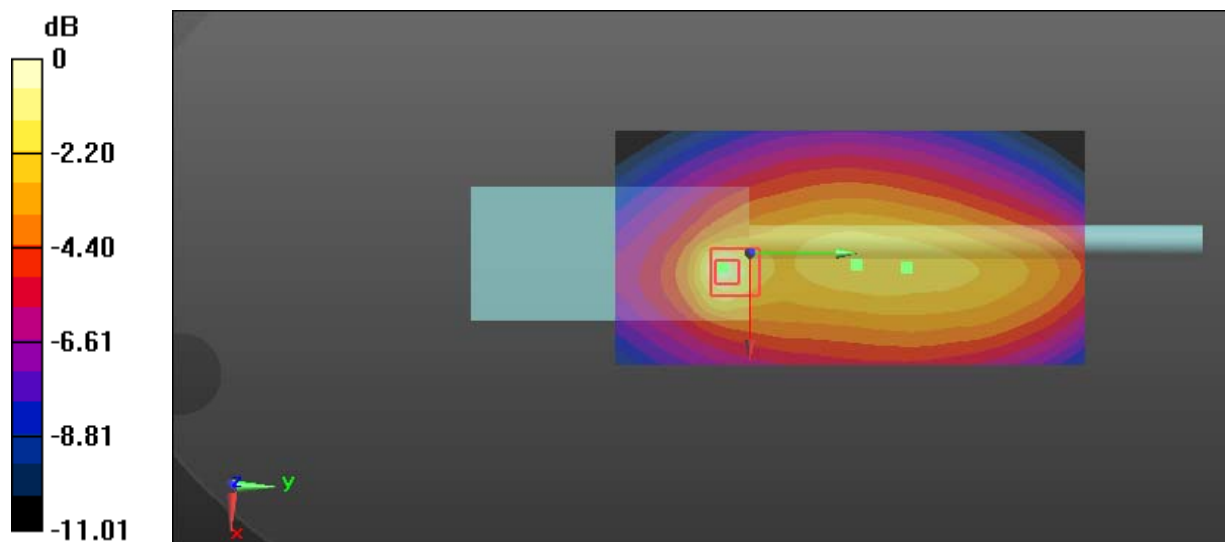

0 dB = 11.3 W/kg = 10.53 dBW/kg



**Test Plot 25#: PTT\_4FSK 12.5KHz\_Face Up\_136.0125 MHz****DUT: Digital Portable Radio; Type: PD782G VHF; Serial: 17090701320**

Communication System: 4FSK; Frequency: 136.012 MHz; Duty Cycle: 1:2

Medium parameters used:  $f = 136.012$  MHz;  $\sigma = 0.771$  S/m;  $\epsilon_r = 53.208$ ;  $\rho = 1000$  kg/m<sup>3</sup>

Phantom section: Flat Section

DASY5 Configuration:

- Probe: EX3DV4 - SN7441; ConvF(13.25, 13.25, 13.25); Calibrated: 2016/11/15;
- Sensor-Surface: 1.4mm (Mechanical Surface Detection)
- Electronics: DAE4 Sn772; Calibrated: 2016/10/25
- Phantom: ELI v8.0; Type: QDOVA004AA; Serial: 2051
- Measurement SW: DASY52, Version 52.8 (8);

**Area Scan (71x141x1):** Interpolated grid: dx=1.500 mm, dy=1.500 mm

Maximum value of SAR (interpolated) = 1.94 W/kg

**Zoom Scan (5x5x7)/Cube 0:** Measurement grid: dx=8mm, dy=8mm, dz=5mm

Reference Value = 38.28 V/m; Power Drift = 0.02 dB

Peak SAR (extrapolated) = 2.28 W/kg

**SAR(1 g) = 1.48 W/kg; SAR(10 g) = 1.13 W/kg**

Maximum value of SAR (measured) = 1.94 W/kg

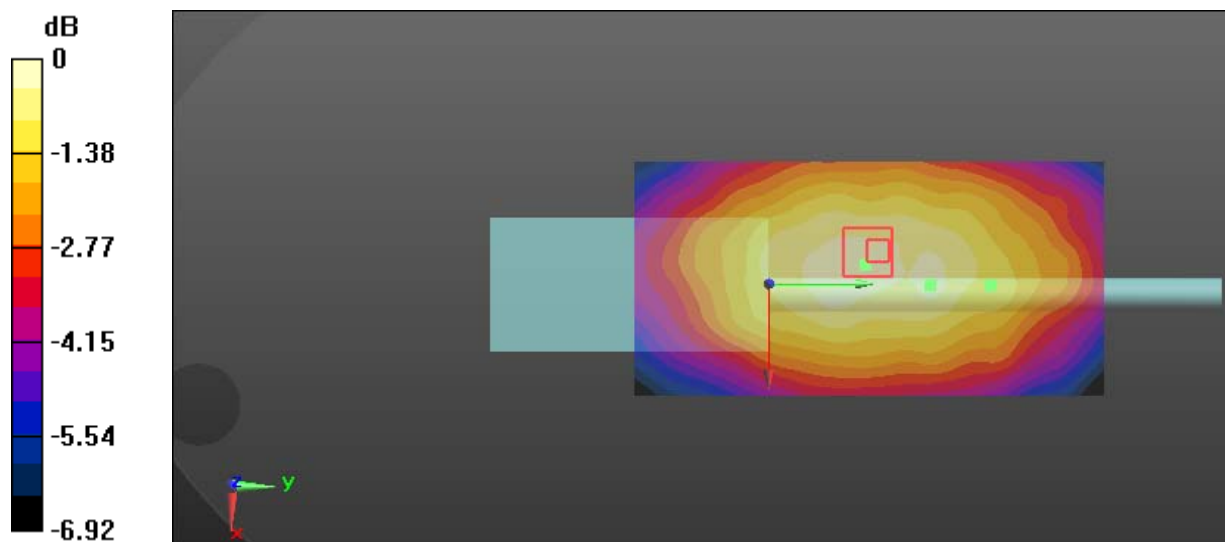

0 dB = 1.94 W/kg = 2.88 dBW/kg

**Test Plot 26#: PTT\_4FSK 12.5KHz\_Face Up\_147.0125 MHz****DUT: Digital Portable Radio; Type: PD782G VHF; Serial: 17090701320**

Communication System: 4FSK; Frequency: 147.012 MHz; Duty Cycle: 1:2

Medium parameters used:  $f = 147.012$  MHz;  $\sigma = 0.782$  S/m;  $\epsilon_r = 53.179$ ;  $\rho = 1000$  kg/m<sup>3</sup>

Phantom section: Flat Section

DASY5 Configuration:

- Probe: EX3DV4 - SN7441; ConvF(13.25, 13.25, 13.25); Calibrated: 2016/11/15;
- Sensor-Surface: 1.4mm (Mechanical Surface Detection)
- Electronics: DAE4 Sn772; Calibrated: 2016/10/25
- Phantom: ELI v8.0; Type: QDOVA004AA; Serial: 2051
- Measurement SW: DASY52, Version 52.8 (8);

**Area Scan (71x141x1):** Interpolated grid: dx=1.500 mm, dy=1.500 mm

Maximum value of SAR (interpolated) = 2.29 W/kg

**Zoom Scan (5x5x7)/Cube 0:** Measurement grid: dx=8mm, dy=8mm, dz=5mm

Reference Value = 42.47 V/m; Power Drift = -0.14 dB

Peak SAR (extrapolated) = 2.64 W/kg

**SAR(1 g) = 1.7 W/kg; SAR(10 g) = 1.27 W/kg**

Maximum value of SAR (measured) = 2.24 W/kg

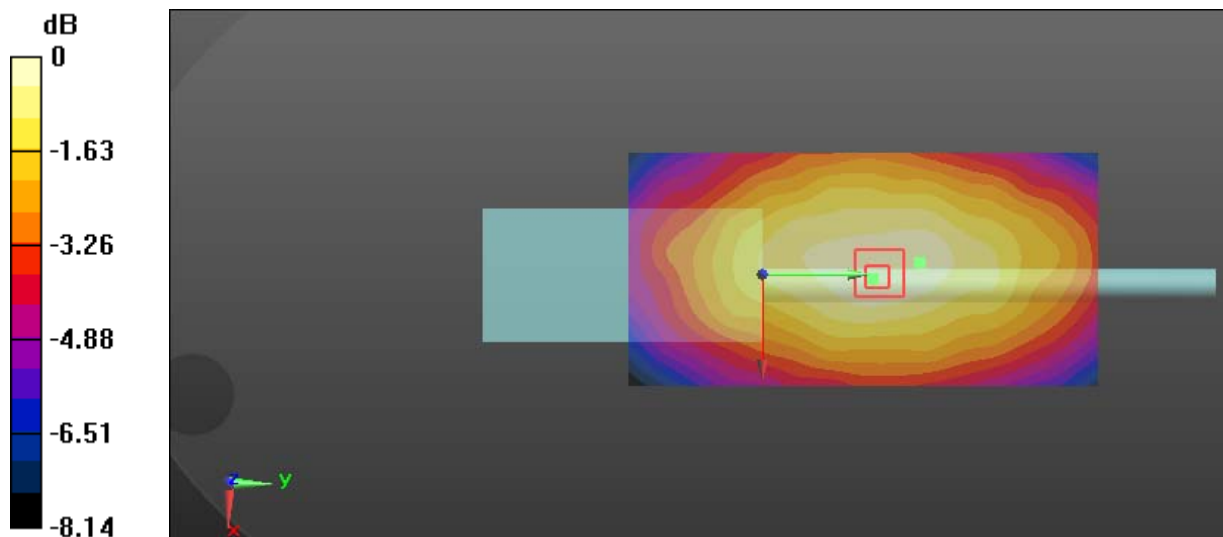

0 dB = 2.24 W/kg = 3.50 dBW/kg

**Test Plot 27#: PTT\_4FSK 12.5KHz\_Face Up\_160.0125 MHz****DUT: Digital Portable Radio; Type: PD782G VHF; Serial: 17090701320**

Communication System: 4FSK; Frequency: 160.012 MHz; Duty Cycle: 1:2

Medium parameters used:  $f = 160.012$  MHz;  $\sigma = 0.792$  S/m;  $\epsilon_r = 52.977$ ;  $\rho = 1000$  kg/m<sup>3</sup>

Phantom section: Flat Section

DASY5 Configuration:

- Probe: EX3DV4 - SN7441; ConvF(13.25, 13.25, 13.25); Calibrated: 2016/11/15;
- Sensor-Surface: 1.4mm (Mechanical Surface Detection)
- Electronics: DAE4 Sn772; Calibrated: 2016/10/25
- Phantom: ELI v8.0; Type: QDOVA004AA; Serial: 2051
- Measurement SW: DASY52, Version 52.8 (8);

**Area Scan (71x141x1):** Interpolated grid: dx=1.500 mm, dy=1.500 mm

Maximum value of SAR (interpolated) = 2.21 W/kg

**Zoom Scan (5x5x7)/Cube 0:** Measurement grid: dx=8mm, dy=8mm, dz=5mm

Reference Value = 40.82 V/m; Power Drift = 0.09 dB

Peak SAR (extrapolated) = 2.50 W/kg

**SAR(1 g) = 1.65 W/kg; SAR(10 g) = 1.26 W/kg**

Maximum value of SAR (measured) = 2.14 W/kg

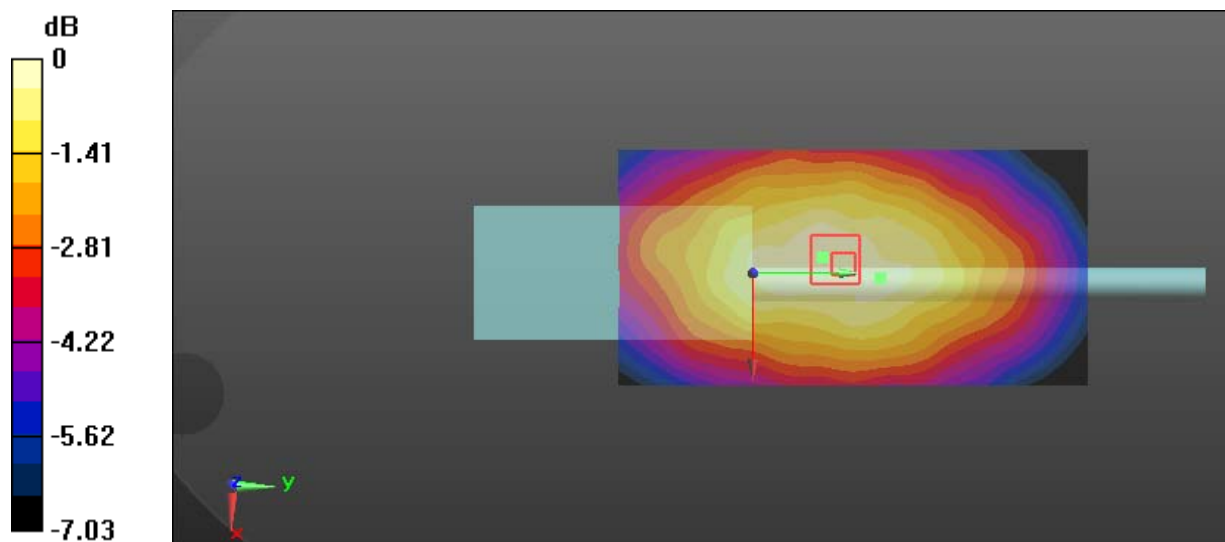

0 dB = 2.14 W/kg = 3.30 dBW/kg

**Test Plot 28#: PTT\_4FSK 12.5KHz\_Body Back\_136.0125 MHz****DUT: Digital Portable Radio; Type: PD782G VHF; Serial: 17090701320**

Communication System: 4FSK; Frequency: 136.012 MHz; Duty Cycle: 1:2

Medium parameters used:  $f = 136.012$  MHz;  $\sigma = 0.817$  S/m;  $\epsilon_r = 60.796$ ;  $\rho = 1000$  kg/m<sup>3</sup>

Phantom section: Flat Section

DASY5 Configuration:

- Probe: EX3DV4 - SN7441; ConvF(12.58, 12.58, 12.58); Calibrated: 2016/11/15;
- Sensor-Surface: 1.4mm (Mechanical Surface Detection)
- Electronics: DAE4 Sn772; Calibrated: 2016/10/25
- Phantom: ELI v8.0; Type: QDOVA004AA; Serial: 2051
- Measurement SW: DASY52, Version 52.8 (8);

**Area Scan (71x141x1):** Interpolated grid: dx=1.500 mm, dy=1.500 mm

Maximum value of SAR (interpolated) = 6.55 W/kg

**Zoom Scan (5x5x7)/Cube 0:** Measurement grid: dx=8mm, dy=8mm, dz=5mm

Reference Value = 57.22 V/m; Power Drift = -0.10 dB

Peak SAR (extrapolated) = 9.94 W/kg

**SAR(1 g) = 3.85 W/kg; SAR(10 g) = 2.17 W/kg**

Maximum value of SAR (measured) = 6.85 W/kg

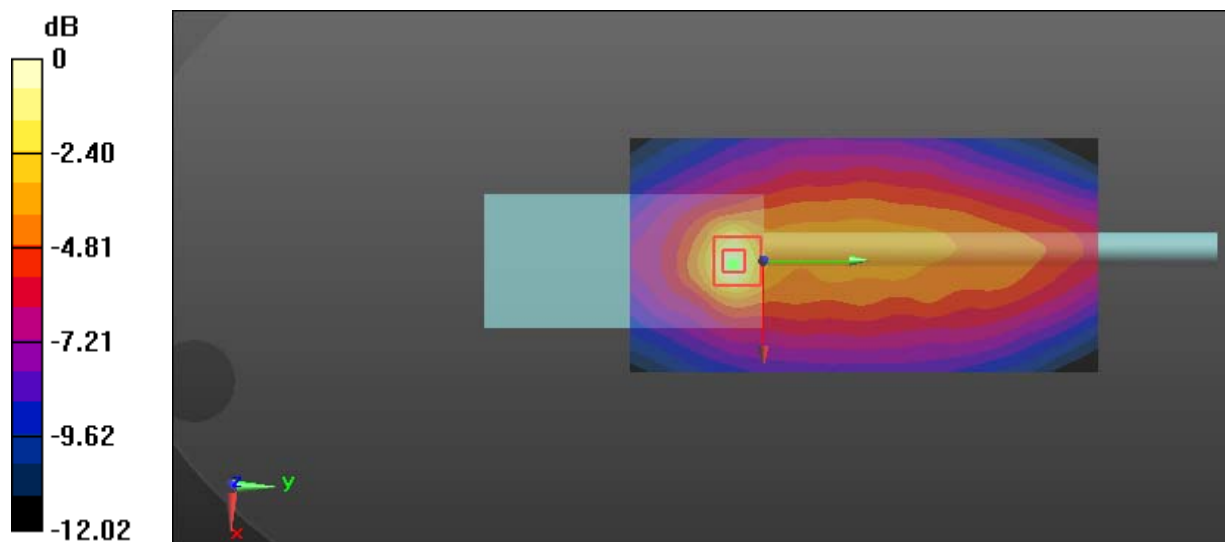

0 dB = 6.85 W/kg = 8.36 dBW/kg

**Test Plot 29#: PTT\_4FSK 12.5KHz\_Body Back\_147.0125 MHz****DUT: Digital Portable Radio; Type: PD782G VHF; Serial: 17090701320**

Communication System: 4FSK; Frequency: 147.012 MHz; Duty Cycle: 1:2

Medium parameters used:  $f = 147.012$  MHz;  $\sigma = 0.824$  S/m;  $\epsilon_r = 60.772$ ;  $\rho = 1000$  kg/m<sup>3</sup>

Phantom section: Flat Section

DASY5 Configuration:

- Probe: EX3DV4 - SN7441; ConvF(12.58, 12.58, 12.58); Calibrated: 2016/11/15;
- Sensor-Surface: 1.4mm (Mechanical Surface Detection)
- Electronics: DAE4 Sn772; Calibrated: 2016/10/25
- Phantom: ELI v8.0; Type: QDOVA004AA; Serial: 2051
- Measurement SW: DASY52, Version 52.8 (8);

**Area Scan (71x141x1):** Interpolated grid: dx=1.500 mm, dy=1.500 mm

Maximum value of SAR (interpolated) = 7.77 W/kg

**Zoom Scan (5x5x7)/Cube 0:** Measurement grid: dx=8mm, dy=8mm, dz=5mm

Reference Value = 63.26 V/m; Power Drift = -0.13 dB

Peak SAR (extrapolated) = 10.6 W/kg

**SAR(1 g) = 4.23 W/kg; SAR(10 g) = 2.46 W/kg**

Maximum value of SAR (measured) = 7.51 W/kg

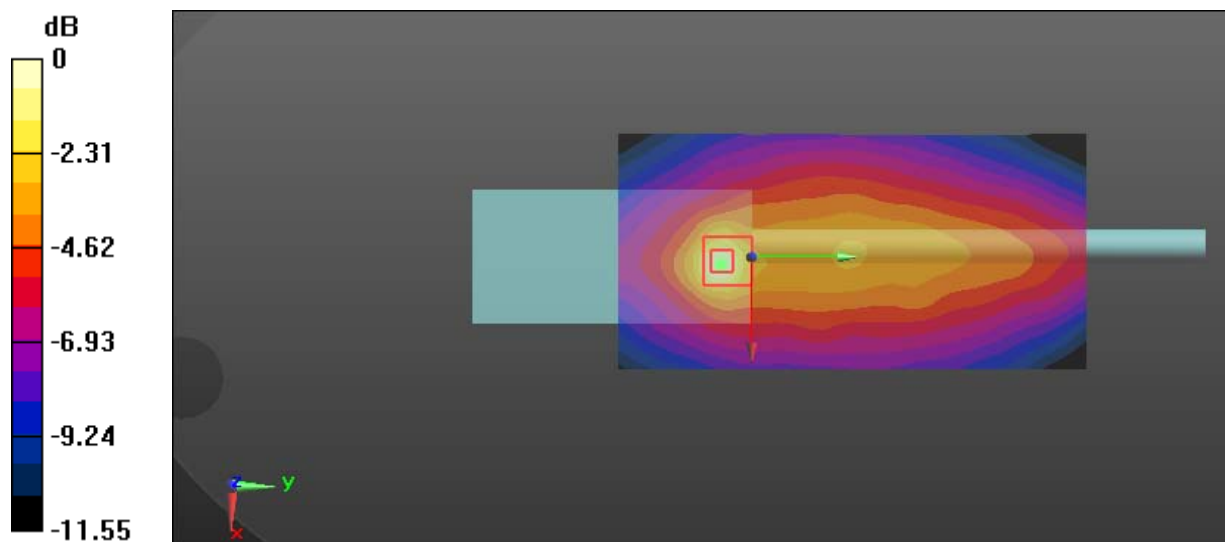

0 dB = 7.51 W/kg = 8.76 dBW/kg

**Test Plot 30#: PTT\_4FSK 12.5KHz\_Body Back\_160.0125 MHz****DUT: Digital Portable Radio; Type: PD782G VHF; Serial: 17090701320**

Communication System: 4FSK; Frequency: 160.012 MHz; Duty Cycle: 1:2

Medium parameters used:  $f = 160.012$  MHz;  $\sigma = 0.835$  S/m;  $\epsilon_r = 60.747$ ;  $\rho = 1000$  kg/m<sup>3</sup>

Phantom section: Flat Section

DASY5 Configuration:

- Probe: EX3DV4 - SN7441; ConvF(12.58, 12.58, 12.58); Calibrated: 2016/11/15;
- Sensor-Surface: 1.4mm (Mechanical Surface Detection)
- Electronics: DAE4 Sn772; Calibrated: 2016/10/25
- Phantom: ELI v8.0; Type: QDOVA004AA; Serial: 2051
- Measurement SW: DASY52, Version 52.8 (8);

**Area Scan (71x141x1):** Interpolated grid: dx=1.500 mm, dy=1.500 mm

Maximum value of SAR (interpolated) = 8.50 W/kg

**Zoom Scan (5x5x7)/Cube 0:** Measurement grid: dx=8mm, dy=8mm, dz=5mm

Reference Value = 72.07 V/m; Power Drift = -0.11 dB

Peak SAR (extrapolated) = 12.9 W/kg

**SAR(1 g) = 5.05 W/kg; SAR(10 g) = 3.05 W/kg**

Maximum value of SAR (measured) = 9.07 W/kg

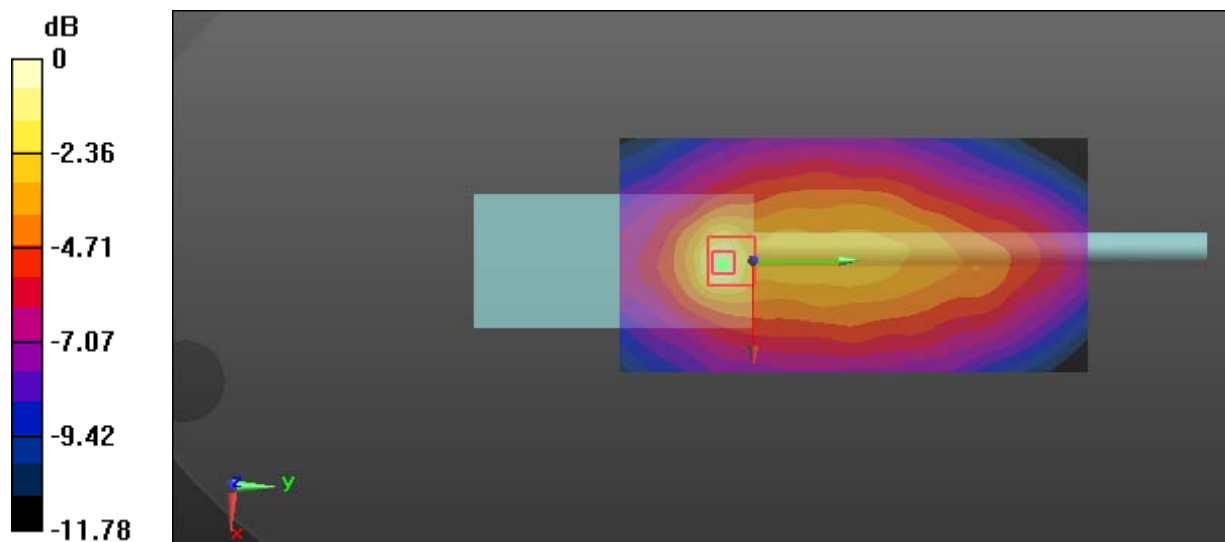

0 dB = 9.07 W/kg = 9.58 dBW/kg