



FCC PART 90 & RSS-119 TEST REPORT

FCC Part 90 and RSS-119

Report Reference No......: **TRE13030165 R/C:76612**

FCC ID.....: **YAMPD78XGU5H**

IC.....: **8913A-PD782GU5H**

Compiled by
 (position+printed name+signature)...: File administrators Tim Zhang

Tim Zhang

Supervised by
 (position+printed name+signature)...: Test Engineer Eric Zhang

Eric Zhang

Approved by
 (position+printed name+signature)...: Manager Wenliang Li

Wenliang Li

Date of issue.....: Apr 20, 2013

Testing Laboratory Name.....: **Shenzhen Huatongwei International Inspection Co., Ltd**

Address.....: Keji Nan No.12 Road, Hi-tech Park, Shenzhen, China

Applicant's name.....: **Hytera Communications Corporation Ltd.**

Address.....: HYT Tower, Hi-Tech Industrial Park North, Nanshan District, Shenzhen China. 518057

Test specification:

Standard.....: **FCC Part 90/FCC Part 2/ FCC Part 15B**
RSS-119/RSS-Gen

TRF Originator.....: Shenzhen Huatongwei International Inspection CO., Ltd

Master TRF.....: Dated 2006-06

Shenzhen Huatongwei International Inspection Co., Ltd. All rights reserved.

This publication may be reproduced in whole or in part for non-commercial purposes as long as the Shenzhen Huatongwei International Inspection Co., Ltd is acknowledged as copyright owner and source of the material. Shenzhen Huatongwei International Inspection Co., Ltd takes no responsibility for and will not assume liability for damages resulting from the reader's interpretation of the reproduced material due to its placement and context.

Test item description.....: Digital Portable Radio

Trade Mark.....: 

Manufacturer.....: **Hytera Communications Corporation Ltd.**

Model/Type reference.....: PD782G U5/PD785G U5/PD786G U5/PD788G U5/
 HD785G U5

Listed Models.....: /

Ratings.....: DC 7.4 V

Modulation.....: FM&4FSK

Channel Separation.....: 25KHz&12.5KHz

Rated Power.....: 3 Watts(34.77dBm)/1 Watts(30.00dBm)

Operation Frequency Range.....: 806-825MHz/851-870MHz/896-902MHz/935-941MHz

Result.....: **Positive**

TEST REPORT

Test Report No. :	TRE13030165	Apr 20, 2013
		Date of issue

Equipment under Test : Digital Portable Radio

Model /Type : PD782G U5/PD785G U5/PD786G U5/PD788G U5/
HD785G U5

Listed Models : /

Applicant : **Hytera Communications Corporation Ltd.**

Address : HYT Tower,Hi-Tech Industrial Park North,Nanshan District,Shenzhen China.518057

Manufacturer : **Hytera Communications Corporation Ltd.**

Address : HYT Tower,Hi-Tech Industrial Park North,Nanshan District,Shenzhen China.518057

Test Result according to the standards on page 4:	Positive
--	-----------------

The test report merely corresponds to the test sample.
It is not permitted to copy extracts of these test result without the written permission of the test laboratory.

Contents

1.	<u>TEST STANDARDS</u>	4
2.	<u>SUMMARY</u>	5
2.1.	General Remarks	5
2.2.	Product Description	5
2.3.	Equipment under Test	5
2.4.	Short description of the Equipment under Test (EUT)	6
2.5.	EUT Configuration	6
2.6.	EUT operation mode	6
2.7.	EUT configuration	6
2.8.	Related Submittal(s) / Grant (s)	7
2.9.	Modifications	7
2.10.	Note	7
3.	<u>TEST ENVIRONMENT</u>	8
3.1.	Address of the test laboratory	8
3.2.	Test Facility	8
3.3.	Environmental conditions	9
3.4.	Configuration of Tested System	9
3.5.	Discription of Tested Modes	9
3.6.	Statement of the measurement uncertainty	9
3.7.	Test Description	10
3.8.	Equipments Used during the Test	10
4.	<u>TEST CONDITIONS AND RESULTS</u>	12
4.1.	Conducted Emissions Test	12
4.2.	Occupied Bandwidth and Emission Mask Test	19
4.3.	Transmitter Radiated Spurious Emssion	73
4.4.	Spurious Emssion on Antenna Port	85
4.5.	Modulation Charcateristics	140
4.6.	Frequency Stability Test	145
4.7.	Maximum Transmitter Power	151
4.8.	Receiver Radiated Spurious Emssion	178
4.9.	Receiver Conducted Spurious Emssion	196
5.	<u>TEST SETUP PHOTOS OF THE EUT</u>	210
6.	<u>EXTERNAL AND INTERNAL PHOTOS OF THE EUT</u>	214

1. TEST STANDARDS

The tests were performed according to following standards:

FCC Rules Part 90: PRIVATE LAND MOBILE RADIO SERVICES.

TIA/EIA 603 D: Land Mobile FM or PM Communications Equipment Measurement and Performance Standards.

47 CFR FCC Part 15 Subpart B - Unintentional Radiators

FCC Part 2: FREQUENCY ALLOCATIONS AND RADIO TREATY MATTERS; GENERAL RULES AND REGULATIONS

RSS-119 Issue 11 June 2011: Radio Transmitters and Receivers Operating in the Land Mobile and Fixed Services in the Frequency Range 27.41-960 MHz

RSS-Gen Issue 3 December 2010: General Requirements and Information for the Certification of Radio Apparatus

2. SUMMARY

2.1. General Remarks

Date of receipt of test sample	:	Apr 01, 2013
Testing commenced on	:	Apr 01, 2013
Testing concluded on	:	Apr 20, 2013

2.2. Product Description

The Hytera Communications Corporation Ltd.'s Model: PD782G U5/PD785G U5/PD786G U5/PD788G U5/HD785G U5 or the "EUT" as referred to in this report; more general information as follows, for more details, refer to the user's manual of the EUT.

Name of EUT	Digital Portable Radio	
Model Number	PD782G U5/PD785G U5/PD786G U5/PD788G U5/ HD785G U5	
FCC ID	YAMPD78XGU5H	
IC	8913A-PD782GU5H	
Rated Output Power	3 Watts(34.77dBm)/1 Watts(30.00dBm) for 806-825MHz/851-870MHz	
	2.5 Watts(33.98dBm)/1 Watts(30.00dBm) for 896-902MHz/935-941MHz	
Support data rate	9.6kbps	
Modulation Type	FM for Analog Voice	
	4FSK for Digital Voice/Digital Data	
	4FSK for Digital Data	
	Analog	16K0F3E for 25KHz Channel Separation 11K0F3E for 12.5KHz Channel Separation
Digital	7K60FXD for Digital Data only	
	7K60FXW for Digital Data & Digital Voice	
Channel Separation	Analog Voice	12.5KHz&25KHz
	Digital Voice/Data	12.5KHz
	Digital Data	12.5KHz
Antenna Type	External	
Frequency Range	806-825MHz/851-870MHz/896-902MHz/935-941MHz	
Maximum Output Power	Analog	3.288 W for 25 KHz Channel Separation
		3.319 W for 12.5 KHz Channel Separation
	Digital	3.334 W for 12.5 KHz Channel Separation

Note: The product has the same digital working characters when operating in both two digitized voice/data mode (7K60FXD and 7K60FXW). So only one set of test results for digital modulation modes are provided in this test report.

2.3. Equipment under Test

Power supply system utilised

Power supply voltage	:	<input type="radio"/> 120V / 60 Hz	<input type="radio"/> 115V / 60Hz
		<input type="radio"/> 12 V DC	<input type="radio"/> 24 V DC
		<input checked="" type="radio"/> Other (specified in blank below)	

DC 7.4V from battery

Test frequency list

Frequency Range (MHz)	Modulation Type	Channel Separation (KHz)	Test Channel	Test Frequency (MHz)	
				TX	RX
806-825	Analog/FM	25	Low Channel	806.5000	851.5000
			Middle Channel	817.0000	860.0000
			High Channel	823.5000	868.5000
		12.5	Low Channel	806.5000	851.5000
			Middle Channel	817.0000	860.0000
			High Channel	823.5000	868.5000
	Digital/4FSK	12.5	Low Channel	806.5000	851.5000
			Middle Channel	817.0000	860.0000
			High Channel	823.5000	868.5000
851-870	Analog/FM	25	Low Channel	851.5000	851.5000
			Middle Channel	860.0000	860.0000
			High Channel	868.5000	868.5000
		12.5	Low Channel	851.5000	851.5000
			Middle Channel	860.0000	860.0000
			High Channel	868.5000	868.5000
	Digital/4FSK	12.5	Low Channel	851.5000	851.5000
			Middle Channel	860.0000	860.0000
			High Channel	868.5000	868.5000
896-902	Analog/FM	12.5	Low Channel	896.5000	935.5000
	Digital/4FSK		High Channel	900.5000	939.5000
			Low Channel	896.5000	935.5000
	High Channel		900.5000	939.5000	
935-941	Analog/FM	12.5	Low Channel	935.5000	935.5000
	Digital/4FSK		High Channel	939.5000	939.5000
			Low Channel	935.5000	935.5000
	High Channel		939.5000	939.5000	

2.4. Short description of the Equipment under Test (EUT)

806-825MHz/851-870MHz/896-902MHz/935-941MHz U frequency band Digital Portable Radio with GPS function (PD782G U5/PD785G U5/PD786G U5/PD788G U5/HD785G U5).

For more details, refer to the user's manual of the EUT.

Serial number: Prototype

2.5. EUT Configuration

The EUT configuration for testing is installed on RF field strength measurement to meet the Commission's requirement and operating in a manner which intends to maximize its emission characteristics in a continuous normal application.

2.6. EUT operation mode

The EUT has been tested under typical operating condition and The Transmitter was operated in the normal operating mode. The TX frequency was fixed which was for the purpose of the measurements.

2.7. EUT configuration

The following peripheral devices and interface cables were connected during the measurement:

● - supplied by the manufacturer

○ - supplied by the lab

<input type="radio"/>	Power Cable	Length (m) :	/
		Shield :	/
		Detachable :	/
<input type="radio"/>	Multimeter	Manufacturer :	/
		Model No. :	/

2.8. Related Submittal(s) / Grant (s)

This submittal(s) (test report) is intended for **FCC ID: YAMPD78XGU5H** and **IC: 8913A-PD782GU5H** filing to comply with FCC Part 90&FCC Part 2&FCC Part 15B Rules and RSS-119&RSS-Gen.

2.9. Modifications

No modifications were implemented to meet testing criteria.

2.10. Note

The EUT is a U frequency band (806-825MHz/851-870MHz/896-902MHz/935-941MHz) Digital Portable Radio with GPS function, The functions of the EUT listed as below:

	Test Standards	Reference Report
Radio	FCC Part 90&RSS-119	TRE13030165
Health	Oet 65&RSS-102	TRE13030164

3. TEST ENVIRONMENT

3.1. Address of the test laboratory

Shenzhen Huatongwei International Inspection Co., Ltd
Keji Nan No.12 Road, Hi-tech Park, Shenzhen, China
Phone: 86-755-26715686 Fax: 86-755-26748089

The sites are constructed in conformance with the requirements of ANSI C63.7, ANSI C63.4 (2009) and CISPR Publication 22.

3.2. Test Facility

The test facility is recognized, certified, or accredited by the following organizations:

CNAS-Lab Code: L1225

Shenzhen Huatongwei International Inspection Co., Ltd. has been assessed and proved to be in compliance with CNAS-CL01 Accreditation Criteria for Testing and Calibration Laboratories (identical to ISO/IEC 17025: 2005 General Requirements) for the Competence of Testing and Calibration Laboratories, Date of Registration: Mar. 01, 2012. Valid time is until Feb. 28, 2015.

A2LA-Lab Cert. No. 2243.01

Shenzhen Huatongwei International Inspection Co., Ltd. EMC Laboratory has been accredited by A2LA for technical competence in the field of electrical testing, and proved to be in compliance with ISO/IEC 17025: 2005 General Requirements for the Competence of Testing and Calibration Laboratories and any additional program requirements in the identified field of testing. Valid time is until Sept. 30, 2013.

FCC-Registration No.: 662850

Shenzhen Huatongwei International Inspection Co., Ltd. EMC Laboratory has been registered and fully described in a report filed with the FCC (Federal Communications Commission). The acceptance letter from the FCC is maintained in our files. Registration 662850, Renewal date June. 01, 2012, valid time is until Jun. 01, 2015.

IC-Registration No.: 5377A

The 3m Alternate Test Site of Shenzhen Huatongwei International Inspection Co., Ltd. has been registered by Certification and Engineering Bureau of Industry Canada for the performance of radiated measurements with Registration No. 5377A on Jan. 25, 2011, valid time is until Jan. 24, 2014.

ACA

Shenzhen Huatongwei International Inspection Co., Ltd. EMC Laboratory can also perform testing for the Australian C-Tick mark as a result of our A2LA accreditation.

NEMKO-Aut. No.: ELA125

Shenzhen Huatongwei International Inspection Co., Ltd has been assessed the quality assurance system, the testing facilities, qualifications and testing practices of the relevant parts of the organization. The quality assurance system of the Laboratory has been validated against ISO/IEC 17025 or equivalent. The laboratory also fulfils the conditions described in Nemko Document NLA-10, the authorization is valid through July 07, 2013

VCCI

The 3m Semi-anechoic chamber (12.2m×7.95m×6.7m) and Shielded Room (8m×4m×3m) of Shenzhen Huatongwei International Inspection Co., Ltd. has been registered in accordance with the Regulations for Voluntary Control Measures with Registration No.: G-292. Date of Registration: Dec. 24, 2010. Valid time is until Dec. 23, 2013.

Main Ports Conducted Interference Measurement of Shenzhen Huatongwei International Inspection Co., Ltd. has been registered in accordance with the Regulations for Voluntary Control Measures with Registration No.: C-2726. Date of Registration: Dec. 20, 2012. Valid time is until Dec. 19, 2015.

Telecommunication Ports Conducted Interference Measurement of Shenzhen Huatongwei International Inspection Co., Ltd. has been registered in accordance with the Regulations for Voluntary Control Measures with Registration No.: T-1837. Date of Registration: May 07, 2010. Valid time is until May 06, 2013.

DNV

Shenzhen Huatongwei International Inspection Co., Ltd. has been found to comply with the requirements of DNV towards subcontractor of EMC and safety testing services in conjunction with the EMC and Low voltage Directives and in the voluntary field. The acceptance is based on a formal quality Audit and follow-ups according to relevant parts of ISO/IEC Guide 17025 (2005), in accordance with the requirements of the DNV Laboratory Quality Manual towards subcontractors. Valid time is until Aug. 24, 2013.

3.3. Environmental conditions

During the measurement the environmental conditions were within the listed ranges:

Temperature:	15-35 ° C
Humidity:	30-60 %
Atmospheric pressure:	950-1050mbar

3.4. Configuration of Tested System

Fig. 2-1 Configuration of Tested System

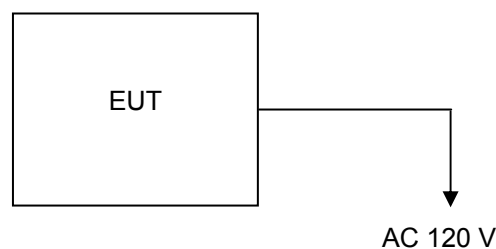

Table 2-1 Equipment Used in Tested System

Adapter: P/N: PS1014
 Model: HKA01212010-2F
 Input: 100-240V~, 0.5A.50/60Hz
 Output: 12V DC 1A
 Power Cable: 180cm
 ◇ Shielded ◆ Unshielded

3.5. Discription of Tested Modes

The EUT (Digital Portable Radio) has been tested under normal operating condition. Three channels (the high, the middle and the low) are chosen for testing at each channel separation (12.5 KHz&25KHz).

3.6. Statement of the measurement uncertainty

The data and results referenced in this document are true and accurate. The reader is cautioned that there may be errors within the calibration limits of the equipment and facilities. The measurement uncertainty was calculated for all measurements listed in this test report acc. to CISPR 16 - 4 „Specification for radio disturbance and immunity measuring apparatus and methods – Part 4: Uncertainty in EMC Measurements“ and is documented in the Shenzhen Huatongwei International Inspection Co., Ltd quality system acc. to DIN EN ISO/IEC 17025. Furthermore, component and process variability of devices similar to that tested may result in additional deviation. The manufacturer has the sole responsibility of continued compliance of the device.

Hereafter the best measurement capability for Shenzhen Huatongwei laboratory is reported:

Test Items	Measurement Uncertainty	Notes
Frequency stability	25 Hz	(1)
Transmitter power conducted	0.57 dB	(1)
Transmitter power Radiated	2.20 dB	(1)
Conducted spurious emission 9KHz-12.75 GHz	1.60 dB	(1)
Radiated spurious emission 9KHz-12.75 GHz	2.20 dB	(1)
Conducted Emission 9KHz-30MHz	3.39 dB	(1)
Radiated Emission 30~1000MHz	4.24 dB	(1)
Radiated Emissio 1~18GHz	5.16 dB	(1)
Radiated Emissio 18-40GHz	5.54 dB	(1)
Occupied Bandwidth	-----	(1)
Emission Mask	-----	(1)
Modulation Characteristic	-----	(1)
Transmitter Frequency Behavior	-----	(1)

(1) This uncertainty represents an expanded uncertainty expressed at approximately the 95% confidence level using a coverage factor of k=1.96.

3.7. Test Description

FCC Rules	Description of Test	Test Result
§ 15.107	Conducted Emission	Complies
§ 15.109	Receiver Radiated Spurious Emssion	Complies
§ 15.109	Receiver Conducted Spurious Emssion	Complies
§ 90.205	Maximum Transmitter Power	Complies
§ 90.207	Modulation Characteristic	Complies
§ 90.209	Occupied Bandwidth	Complies
§ 90.210	Emission Mask	Complies
§ 90.213	Frequency Stability	Complies
§ 90.214	Transmitter Frequency Behavior	N/A
§ 90.210	Transmitter Radiated Spurious Emssion	Complies
§ 90.210	Spurious Emssion On Antenna Port	Complies

3.8. Equipments Used during the Test

AC Power Conducted Emission				
Name of Equipment	Manufacturer	Model	Serial Number	Calibration Due
EMI Test Receiver	Rohde&Schwarz	ESCI	100106	10/27/2013
Pulse Limiter	Rohde&Schwarz	ESHSZ2	100044	10/27/2013
EMI Test Software	Rohde&Schwarz	ES-K1 V1.71	N/A	10/27/2013
Artificial Mains	Rohde&Schwarz	ESH3-Z6	100210	10/27/2013
Artificial Mains	Rohde&Schwarz	ESH3-Z6	100211	10/27/2013
RF COMMUNICATION TEST SET	HP	8920A	3813A10206	10/27/2013

Modulation Characteristic				
Name of Equipment	Manufacturer	Model	Serial Number	Calibration Due
RF COMMUNICATION TEST SET	HP	8920A	3813A10206	10/27/2013

Transmitter Radiated Spurious Emission & Occupied Bandwidth & Emission Mask & Receiver Radiated Spurious Emission				
Name of Equipment	Manufacturer	Model	Serial Number	Calibration Due
Ultra-Broadband Antenna	Rohde&Schwarz	HL562	100015	10/27/2013
EMI Test Receiver	Rohde&Schwarz	ESI 26	100009	10/27/2013
RF Test Panel	Rohde&Schwarz	TS / RSP	335015/ 0017	N/A
HORN ANTENNA	Rohde&Schwarz	HF906	100039	10/27/2013
Turntable	ETS	2088	2149	N/A
Antenna Mast	ETS	2075	2346	N/A
EMI Test Software	Rohde&Schwarz	ES-K1 V1.71	N/A	10/27/2013
RF COMMUNICATION TEST SET	HP	8920A	3813A10206	10/27/2013
Spectrum Analyzer	Aglient	E4407B	MY44210775	10/27/2013
Spectrum Analyzer	Rohde&Schwarz	FSP40	1164.4391.40	10/27/2013
High pass filter	Compliance Direction systems	BSU-6	34202	10/27/2013

Frequency Stability				
Name of Equipment	Manufacturer	Model	Serial Number	Calibration Due
Communication Test Set	HP	HP8920B	US35010135	10/27/2013
Signal Generator	Rohde&Schwarz	SMT03	100059	10/27/2013
Climate Chamber	ESPEC	EL-10KA	05107008	10/27/2013

Maximum Transmitter Power & Spurious Emission On Antenna Port				
Name of Equipment	Manufacturer	Model	Serial Number	Calibration Due
Receiver	Rohde&Schwarz	ESI 26	100009	10/27/2013
Attenuator	R&S	ESH3-22	100449	10/27/2013
RF COMMUNICATION TEST SET	HP	8920A	3813A10206	10/27/2013
High-Pass Filter	Anritsu	MP526B	6220875256	10/27/2013
High-Pass Filter	Anritsu	MP526D	6220878392	10/27/2013
High pass filter	Compliance Direction systems	BSU-6	34202	10/27/2013
Spectrum Analyzer	Rohde&Schwarz	FSP40	1164.4391.40	10/27/2013

The calibration interval was one year.

4. TEST CONDITIONS AND RESULTS

4.1. Conducted Emissions Test

TEST APPLICABLE

The EUT was tested according to ANSI C63.4 - 2009. The frequency spectrum from 0.15 MHz to 30 MHz was investigated. The LISN used was 50 ohm / 50 u Henry as specified by section 5.1 of ANSI C63.4 - 2009. Cables and peripherals were moved to find the maximum emission levels for each frequency.

TEST CONFIGURATION

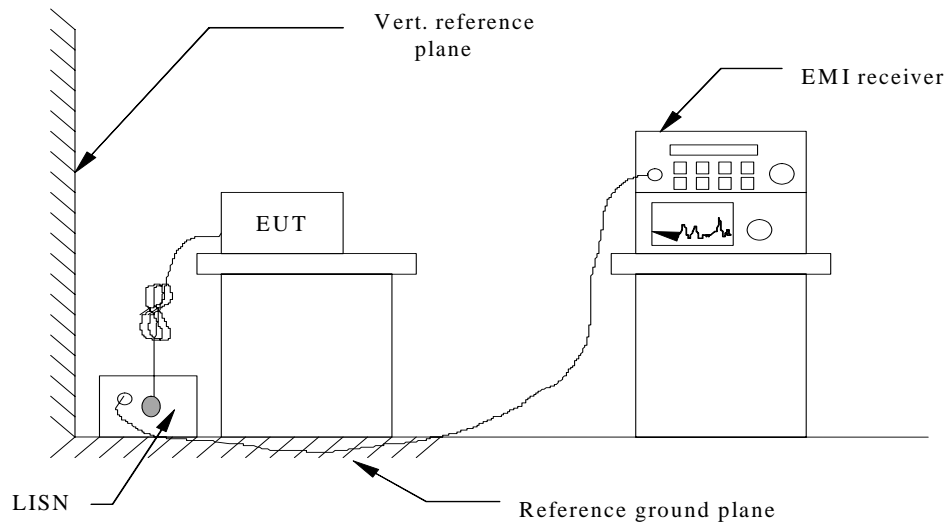

TEST PROCEDURE

- 1 The equipment was set up as per the test configuration to simulate typical actual usage per the user's manual. The EUT is a tabletop system; a wooden table with a height of 0.8 meters is used and is placed on the ground plane as per ANSI C63.4-2009.
- 2 Support equipment, if needed, was placed as per ANSI C63.4-2009.
- 3 All I/O cables were positioned to simulate typical actual usage as per ANSI C63.4-2009.
- 4 If a EUT received DC power from the adapter, the adapter received AC120V/60Hz power through a Line Impedance Stabilization Network (LISN) which supplied power source and was grounded to the ground plane.
- 5 All support equipments received AC power from a second LISN, if any.
- 6 The EUT test program was started. Emissions were measured on each current carrying line of the EUT using a spectrum Analyzer / Receiver connected to the LISN powering the EUT. The LISN has two monitoring points: Line 1 (Hot Side) and Line 2 (Neutral Side). Two scans were taken: one with Line 1 connected to Analyzer / Receiver and Line 2 connected to a 50 ohm load; the second scan had Line 1 connected to a 50 ohm load and Line 2 connected to the Analyzer / Receiver.
- 7 Analyzer / Receiver scanned from 150 KHz to 30MHz for emissions in each of the test modes.
- 8 During the above scans, the emissions were maximized by cable manipulation.

Conducted Power Line Emission Limit

For unintentional device, according to § 15.107(a) Line Conducted Emission Limits is as following :

Frequency (MHz)	Maximum RF Line Voltage (dB μ V)			
	CLASS A		CLASS B	
	Q.P.	Ave.	Q.P.	Ave.
0.15 - 0.50	79	66	66-56*	56-46*
0.50 - 5.00	73	60	56	46
5.00 - 30.0	73	60	60	50

* Decreasing linearly with the logarithm of the frequency

For intentional device, according to §15.207(a) Line Conducted Emission Limit is same as above table.

TEST RESULTS

For FM Modulation @ 25 KHz

SCAN TABLE: "Voltage (9K-30M) FIN"

Short Description: 150K-30M Voltage

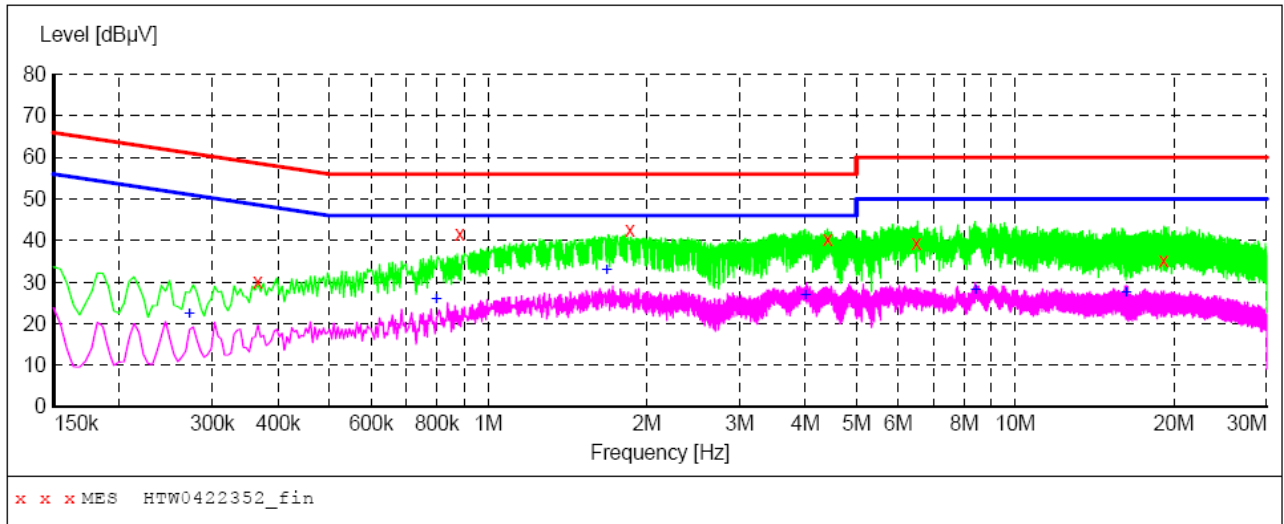

MEASUREMENT RESULT: "HTW0422352_fin"

4/23/2013 8:28AM

Frequency MHz	Level dBµV	Transd dB	Limit dBµV	Margin dB	Detector	Line	PE
0.366000	30.30	10.3	59	28.3	QP	N	GND
0.883500	41.60	10.1	56	14.4	QP	N	GND
1.860000	42.70	10.2	56	13.3	QP	N	GND
4.407000	40.30	10.2	56	15.7	QP	N	GND
6.490500	39.30	10.2	60	20.7	QP	N	GND
19.131000	35.20	10.4	60	24.8	QP	N	GND

MEASUREMENT RESULT: "HTW0422352_fin2"

4/23/2013 8:28AM

Frequency MHz	Level dBµV	Transd dB	Limit dBµV	Margin dB	Detector	Line	PE
0.271500	22.50	10.2	51	28.6	AV	N	GND
0.798000	25.90	10.1	46	20.1	AV	N	GND
1.680000	33.00	10.2	46	13.0	AV	N	GND
3.997500	26.80	10.2	46	19.2	AV	N	GND
8.416500	28.20	10.3	50	21.8	AV	N	GND
16.246500	27.60	10.4	50	22.4	AV	N	GND

SCAN TABLE: "Voltage (9K-30M)FIN"
 Short Description: 150K-30M Voltage

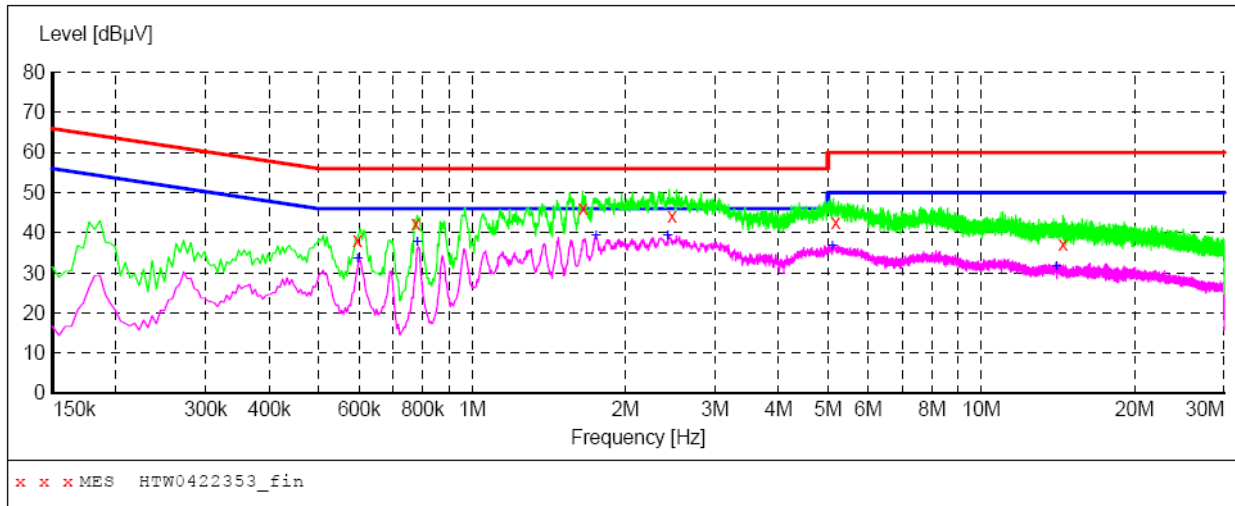

MEASUREMENT RESULT: "HTW0422353_fin"

4/23/2013 8:32AM

Frequency MHz	Level dBµV	Transd dB	Limit dBµV	Margin dB	Detector	Line	PE
0.595500	38.20	10.2	56	17.8	QP	L1	GND
0.775500	42.30	10.1	56	13.7	QP	L1	GND
1.653000	46.00	10.2	56	10.0	QP	L1	GND
2.472000	44.30	10.2	56	11.7	QP	L1	GND
5.176500	42.70	10.2	60	17.3	QP	L1	GND
14.482500	37.10	10.3	60	22.9	QP	L1	GND

MEASUREMENT RESULT: "HTW0422353_fin2"

4/23/2013 8:32AM

Frequency MHz	Level dBµV	Transd dB	Limit dBµV	Margin dB	Detector	Line	PE
0.595500	33.50	10.2	46	12.5	AV	L1	GND
0.780000	37.80	10.1	46	8.2	AV	L1	GND
1.752000	39.30	10.2	46	6.7	AV	L1	GND
2.422500	39.30	10.2	46	6.7	AV	L1	GND
5.100000	36.90	10.2	50	13.1	AV	L1	GND
14.041500	31.60	10.3	50	18.4	AV	L1	GND

For FM Modulation @ 12.5 KHz

SCAN TABLE: "Voltage (9K-30M) FIN"

Short Description: 150K-30M Voltage

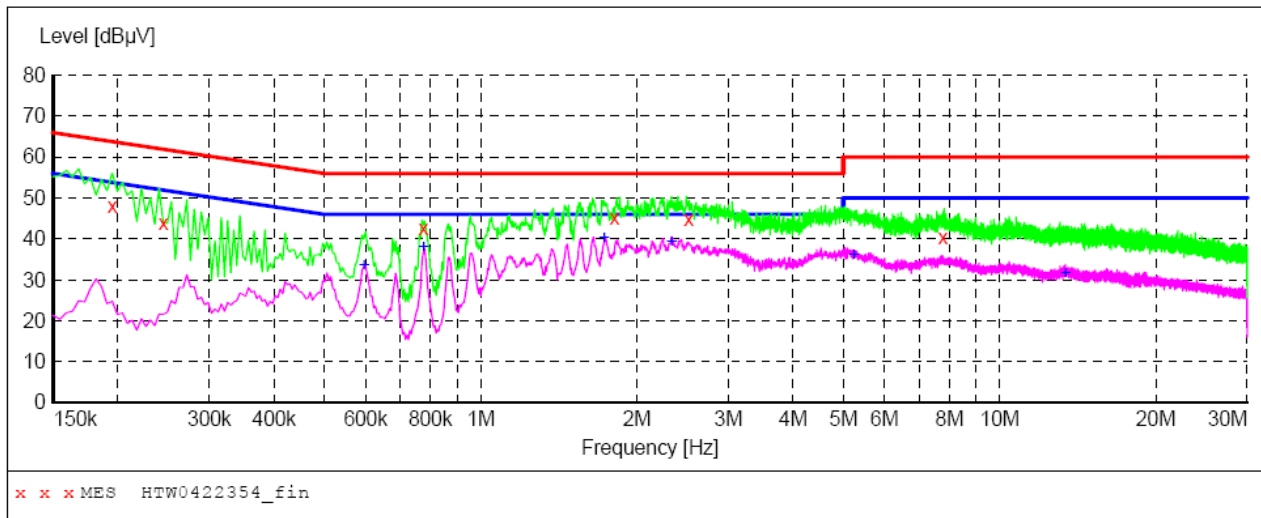

MEASUREMENT RESULT: "HTW0422354_fin"

4/23/2013 8:34AM

Frequency MHz	Level dBµV	Transd dB	Limit dBµV	Margin dB	Detector	Line	PE
0.195000	48.00	10.2	64	15.8	QP	L1	GND
0.244500	44.00	10.2	62	17.9	QP	L1	GND
0.775500	42.60	10.1	56	13.4	QP	L1	GND
1.810500	45.10	10.2	56	10.9	QP	L1	GND
2.517000	44.80	10.2	56	11.2	QP	L1	GND
7.786500	40.50	10.3	60	19.5	QP	L1	GND

MEASUREMENT RESULT: "HTW0422354_fin2"

4/23/2013 8:34AM

Frequency MHz	Level dBµV	Transd dB	Limit dBµV	Margin dB	Detector	Line	PE
0.595500	33.80	10.2	46	12.2	AV	L1	GND
0.775500	38.10	10.1	46	7.9	AV	L1	GND
1.729500	40.50	10.2	46	5.5	AV	L1	GND
2.332500	39.40	10.2	46	6.6	AV	L1	GND
5.244000	36.30	10.2	50	13.7	AV	L1	GND
13.389000	31.90	10.3	50	18.1	AV	L1	GND

SCAN TABLE: "Voltage (9K-30M) FIN"

Short Description: 150K-30M Voltage

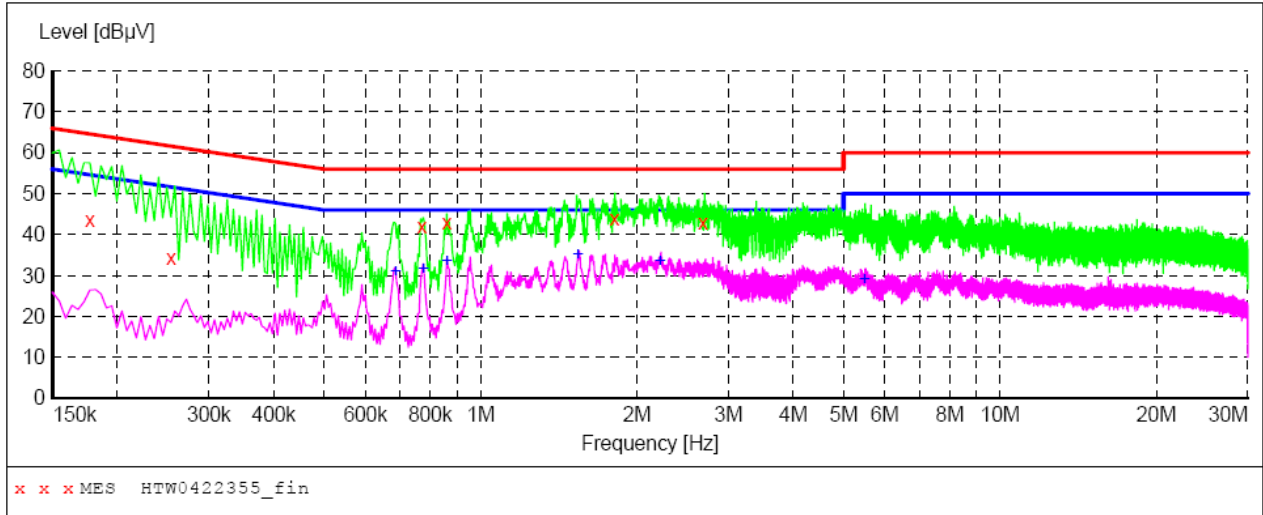

MEASUREMENT RESULT: "HTW0422355_fin"

4/23/2013 8:37AM

Frequency MHz	Level dBµV	Transd dB	Limit dBµV	Margin dB	Detector	Line	PE
0.177000	43.60	10.2	65	21.0	QP	N	GND
0.253500	34.40	10.2	62	27.2	QP	N	GND
0.771000	42.10	10.1	56	13.9	QP	N	GND
0.861000	43.00	10.1	56	13.0	QP	N	GND
1.810500	44.00	10.2	56	12.0	QP	N	GND
2.679000	42.90	10.2	56	13.1	QP	N	GND

MEASUREMENT RESULT: "HTW0422355_fin2"

4/23/2013 8:37AM

Frequency MHz	Level dBµV	Transd dB	Limit dBµV	Margin dB	Detector	Line	PE
0.685500	31.00	10.1	46	15.0	AV	N	GND
0.775500	31.60	10.1	46	14.4	AV	N	GND
0.861000	33.70	10.1	46	12.3	AV	N	GND
1.540500	35.40	10.2	46	10.6	AV	N	GND
2.215500	33.50	10.2	46	12.5	AV	N	GND
5.482500	29.30	10.2	50	20.7	AV	N	GND

For FSK Modulation @ 12.5 KHz

SCAN TABLE: "Voltage (9K-30M) FIN"
 Short Description: 150K-30M Voltage

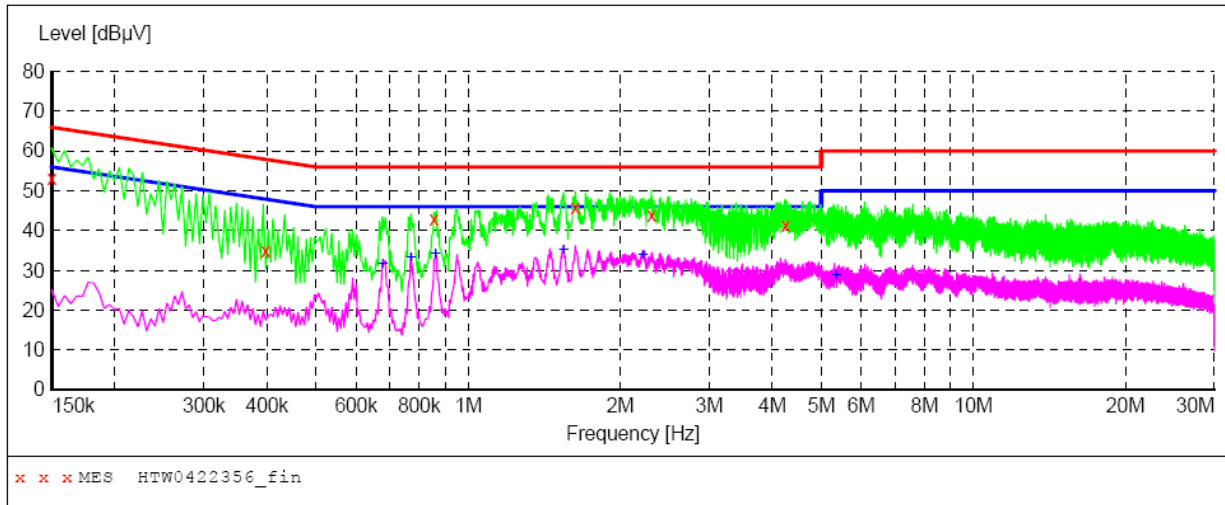

MEASUREMENT RESULT: "HTW0422356_fin"

4/23/2013 8:40AM

Frequency MHz	Level dBµV	Transd dB	Limit dBµV	Margin dB	Detector	Line	PE
0.150000	53.10	10.2	66	12.9	QP	N	GND
0.397500	35.00	10.3	58	22.9	QP	N	GND
0.856500	42.80	10.1	56	13.2	QP	N	GND
1.630500	45.70	10.2	56	10.3	QP	N	GND
2.305500	43.90	10.2	56	12.1	QP	N	GND
4.249500	41.20	10.2	56	14.8	QP	N	GND

MEASUREMENT RESULT: "HTW0422356_fin2"

4/23/2013 8:40AM

Frequency MHz	Level dBµV	Transd dB	Limit dBµV	Margin dB	Detector	Line	PE
0.676500	31.90	10.1	46	14.1	AV	N	GND
0.771000	33.20	10.1	46	12.8	AV	N	GND
0.861000	34.30	10.1	46	11.7	AV	N	GND
1.545000	35.30	10.2	46	10.7	AV	N	GND
2.220000	33.90	10.2	46	12.1	AV	N	GND
5.352000	28.90	10.2	50	21.1	AV	N	GND

SCAN TABLE: "Voltage (9K-30M)FIN"

Short Description: 150K-30M Voltage

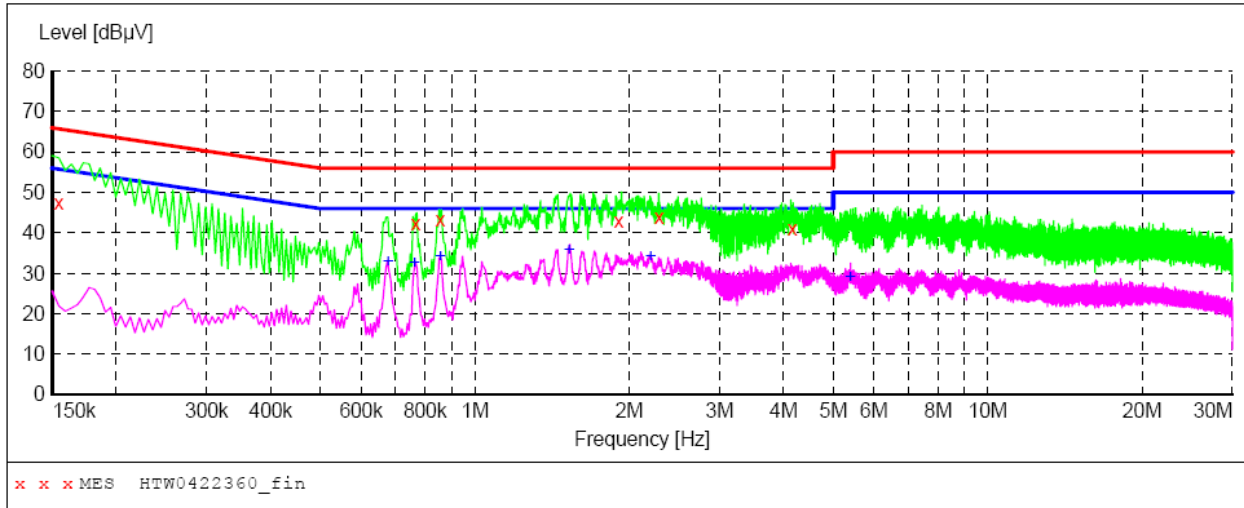

MEASUREMENT RESULT: "HTW0422360_fin"

4/23/2013 8:57AM

Frequency MHz	Level dBµV	Transd dB	Limit dBµV	Margin dB	Detector	Line	PE
0.154500	47.50	10.2	66	18.3	QP	L1	GND
0.766500	42.40	10.1	56	13.6	QP	L1	GND
0.856500	43.30	10.1	56	12.7	QP	L1	GND
1.909500	43.00	10.2	56	13.0	QP	L1	GND
2.287500	43.90	10.2	56	12.1	QP	L1	GND
4.159500	40.90	10.2	56	15.1	QP	L1	GND

MEASUREMENT RESULT: "HTW0422360_fin2"

4/23/2013 8:57AM

Frequency MHz	Level dBµV	Transd dB	Limit dBµV	Margin dB	Detector	Line	PE
0.676500	32.90	10.1	46	13.1	AV	L1	GND
0.762000	32.60	10.1	46	13.4	AV	L1	GND
0.856500	34.40	10.1	46	11.6	AV	L1	GND
1.527000	35.90	10.2	46	10.1	AV	L1	GND
2.202000	34.20	10.2	46	11.8	AV	L1	GND
5.401500	29.20	10.2	50	20.8	AV	L1	GND

4.2. Occupied Bandwidth and Emission Mask Test

TEST APPLICABLE

- (a). Occupied Bandwidth: The EUT was connected to the audio signal generator and the spectrum analyzer via the main RF connector, and through an appropriate attenuator. The EUT was controlled to transmit its maximum power. Then the bandwidth of 99% power can be measured by the spectrum analyzer.
- (b). Emission Mask B: For transmitters that are equipped with an audio low-pass filter pursuant to §90.211(a), the power of any emission must be below the unmodulated carrier power (P) as follows:
- (1) On any frequency removed from the assigned frequency by more than 50 percent, but not more than 100 percent of the authorized bandwidth: At least 25 dB.
 - (2) On any frequency removed from the assigned frequency by more than 100 percent, but not more than 250 percent of the authorized bandwidth: At least 35 dB.
 - (3) On any frequency removed from the assigned frequency by more than 250 percent of the authorized bandwidth: At least $43 + 10 \log (P)$ dB.
- (c). Emission Mask D, 12.5 kHz channel bandwidth equipment: For transmitters designed to operate with a 12.5 kHz channel bandwidth, any emission must be attenuated below the power (P) of the highest emission contained within the authorized bandwidth as follows:
- (1) On any frequency from the center of the authorized bandwidth f_0 to 5.625 kHz removed from f_0 : Zero dB.
 - (2) On any frequency removed from the center of the authorized bandwidth by a displacement frequency (f_d in kHz) of more than 5.625 kHz but no more than 12.5 kHz: At least $7.27(f_d - 2.88 \text{ kHz})$ dB.
 - (3) On any frequency removed from the center of the authorized bandwidth by a displacement frequency (f_d in kHz) of more than 12.5 kHz: At least $50 + 10 \log (P)$ dB or 70 dB, whichever is the lesser attenuation.
- (d). Emission Mask I: For transmitters that are equipped with an audio low-pass filter pursuant to §90.211(a), the power of any emission must be below the unmodulated carrier power (P) as follows:
- (1) On any frequency removed from the center of the authorized bandwidth by a displacement frequency of more than 6.8 kHz, but no more than 9.0 kHz: At least 25 dB;
 - (2) On any frequency removed from the center of the authorized bandwidth by a displacement frequency of more than 9.0 kHz, but no more than 15 kHz: At least 35 dB;
 - (3) On any frequency removed from the center of the authorized bandwidth by a displacement frequency of more than 15 kHz: At least $43 + 10 \log (P)$ dB, or 70 dB, whichever is the lesser attenuation.

TEST CONFIGURATION

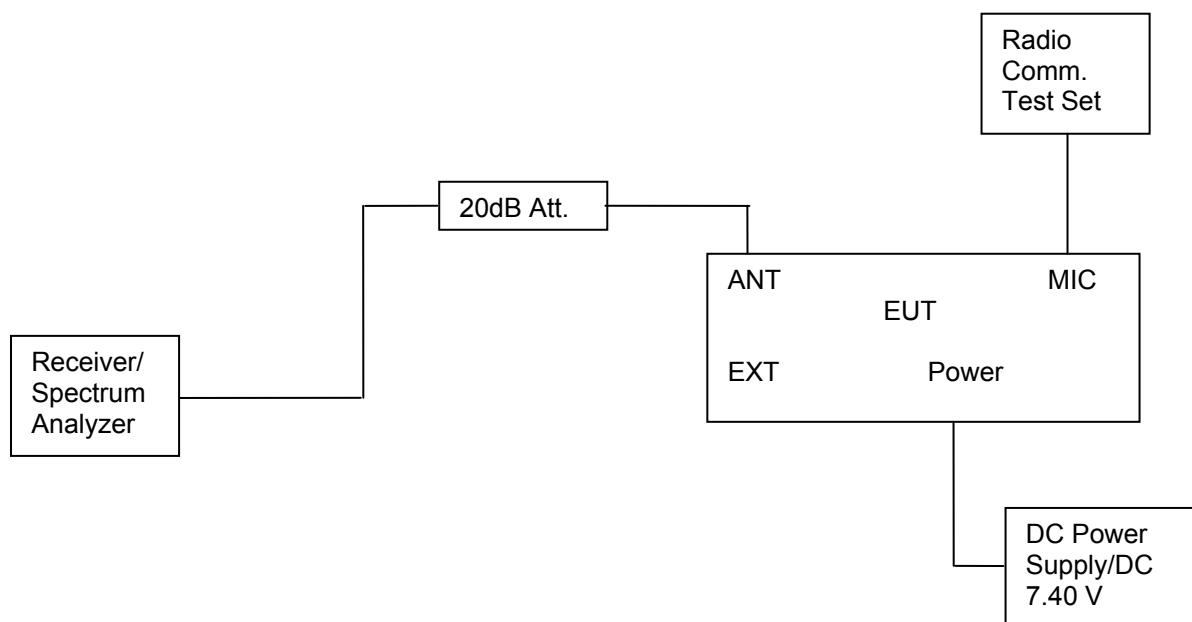

TEST PROCEDURE

- 1 The EUT was placed on a turn table which is 0.8m above ground plane.
- 2 The EUT was modulated by 2.5 KHz Sine wave audio signal; the level of the audio signal employed is 16 dB greater than that necessary to produce 50% of rated system deviation. Rated system deviation is 2.5 kHz (12.5 kHz channel spacing) and 5 kHz (25 kHz channel spacing).
- 3 Set EUT as normal operation.

- 4 Set SPA Center Frequency = fundamental frequency, RBW=300Hz, VBW= 3 KHz, span =50 KHz.
- 5 Set SPA Max hold. Mark peak, Set 99% Occupied Bandwidth and 26dB Occupied Bandwidth.
- 6 Set SPA Center Frequency=fundamental frequency, set =100Hz, VBW=1 KHz, span=50 KHz for 12.5 channel spacing.

TEST RESULTS

4.2.1 Occupied Bandwidth

Frequency Range (MHz)	Modulation Type	Channel Separation (KHz)	Test Channel	Occupied Bandwidth (KHz)	
				99%	26dB
806-825	Analog/FM	25	Low	14.90	15.80
			Middle	15.00	15.80
			High	14.90	15.80
		12.5	Low	9.90	10.60
			Middle	9.80	10.60
			High	9.80	10.60
	Digital/4FSK	12.5	Low	7.60	9.80
			Middle	7.70	9.30
			High	7.80	10.30
851-870	Analog/FM	25	Low	15.00	15.80
			Middle	14.90	15.90
			High	15.00	15.80
		12.5	Low	9.90	10.60
			Middle	9.90	10.60
			High	9.90	10.60
	Digital/4FSK	12.5	Low	7.90	9.40
			Middle	7.40	9.50
			High	7.20	10.00
896-902	Analog/FM	12.5	Low	10.00	10.60
			High	10.00	10.60
	Digital/4FSK		Low	7.70	10.10
			High	7.60	10.00
935-941	Analog/FM	12.5	Low	9.80	10.60
			High	9.90	10.60
	Digital/4FSK		Low	7.50	10.00
			High	7.10	10.10
Limit	806-825MHz/851-870MHz		11.25KHz for 12.5KHz Channel Separation		
	896-902MHz/935-941MHz		20KHz for 25KHz Channel Separation		
Test Results			13.6KHz for 12.5KHz Channel Separation		
			Compliance		

Plots of 99% and 26dB Bandwidth Measurement

Modulation Type	Channel Separation	Freq.(MHz)	99% Bandwidth (KHz)	26dB Bandwidth (KHz)	FCC Limit (KHz)	Results
FM	25 KHz	806.5000	14.90	15.80	20.00	Compliance

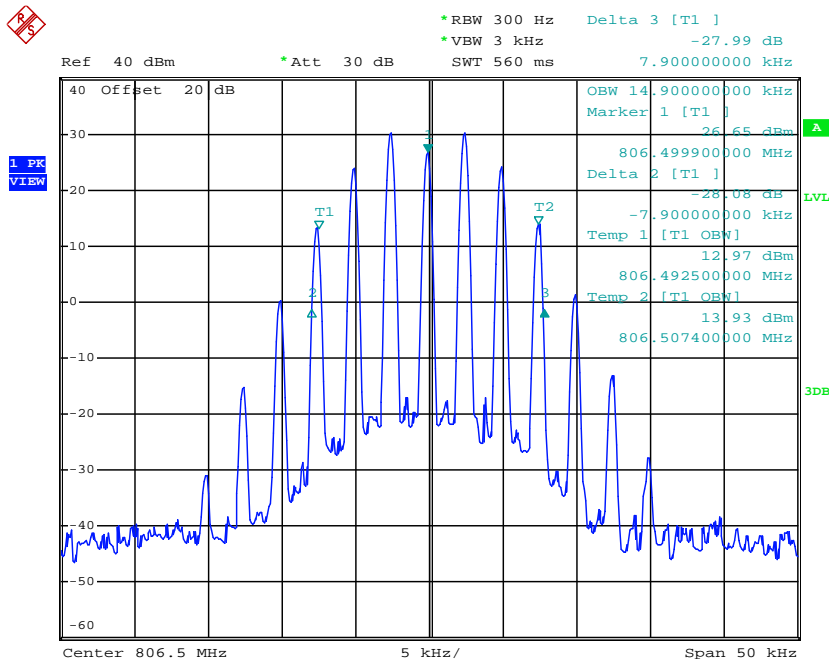

Date: 1.APR.2013 15:48:21

Modulation Type	Channel Separation	Freq.(MHz)	99% Bandwidth (KHz)	26dB Bandwidth (KHz)	FCC Limit (KHz)	Results
FM	25 KHz	817.0000	15.00	15.80	20.00	Compliance

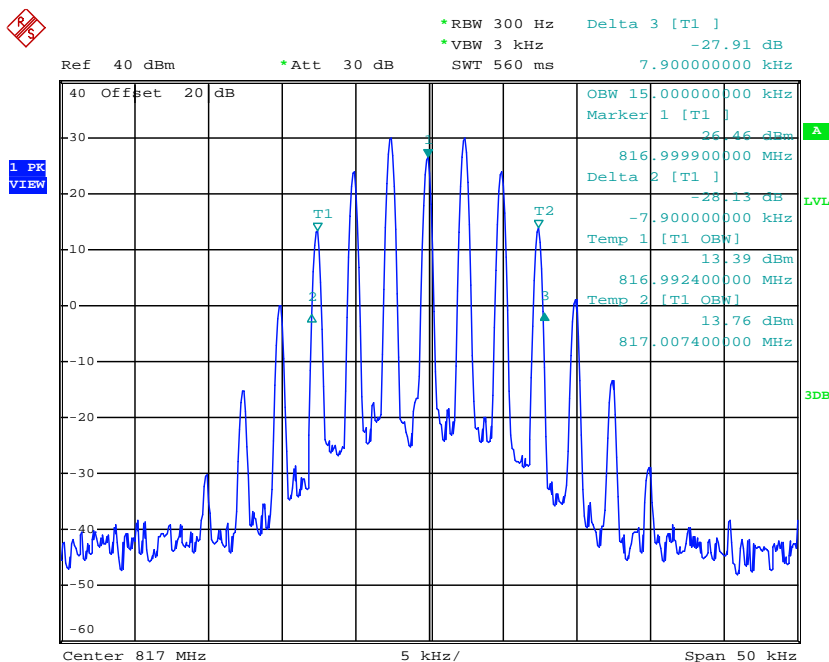

Date: 1.APR.2013 15:49:20

Modulation Type	Channel Separation	Freq.(MHz)	99% Bandwidth (KHz)	26dB Bandwidth (KHz)	FCC Limit (KHz)	Results
FM	25 KHz	823.5000	14.90	15.80	20.00	Compliance

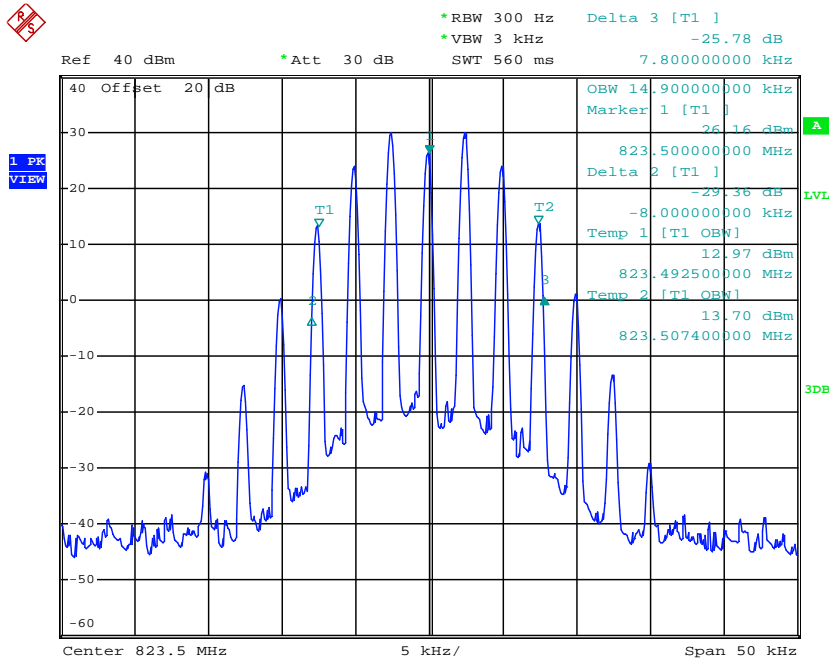

Date: 1.APR.2013 16:08:42

Modulation Type	Channel Separation	Freq.(MHz)	99% Bandwidth (KHz)	26dB Bandwidth (KHz)	FCC Limit (KHz)	Results
FM	25 KHz	851.5000	15.00	15.80	20.00	Compliance

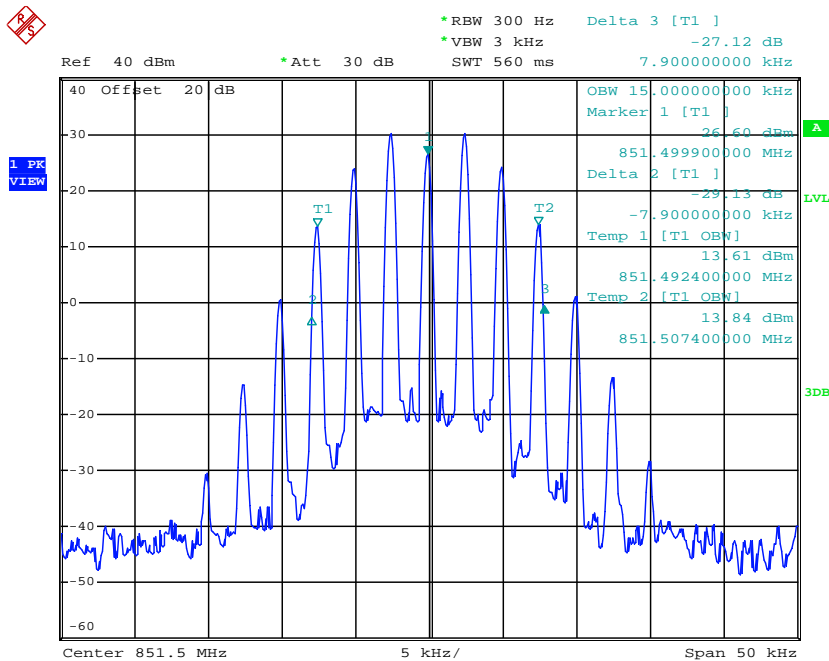

Date: 1.APR.2013 15:30:51

Modulation Type	Channel Separation	Freq.(MHz)	99% Bandwidth (KHz)	26dB Bandwidth (KHz)	FCC Limit (KHz)	Results
FM	25 KHz	860.0000	14.90	15.90	20.00	Compliance

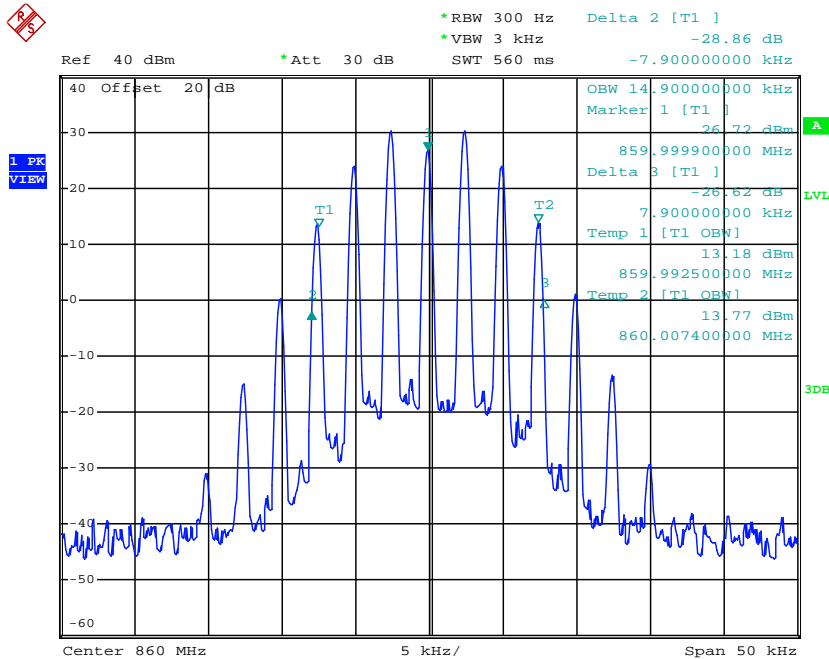

Date: 1.APR.2013 15:31:58

Modulation Type	Channel Separation	Freq.(MHz)	99% Bandwidth (KHz)	26dB Bandwidth (KHz)	FCC Limit (KHz)	Results
FM	25 KHz	868.5000	15.00	15.80	20.00	Compliance

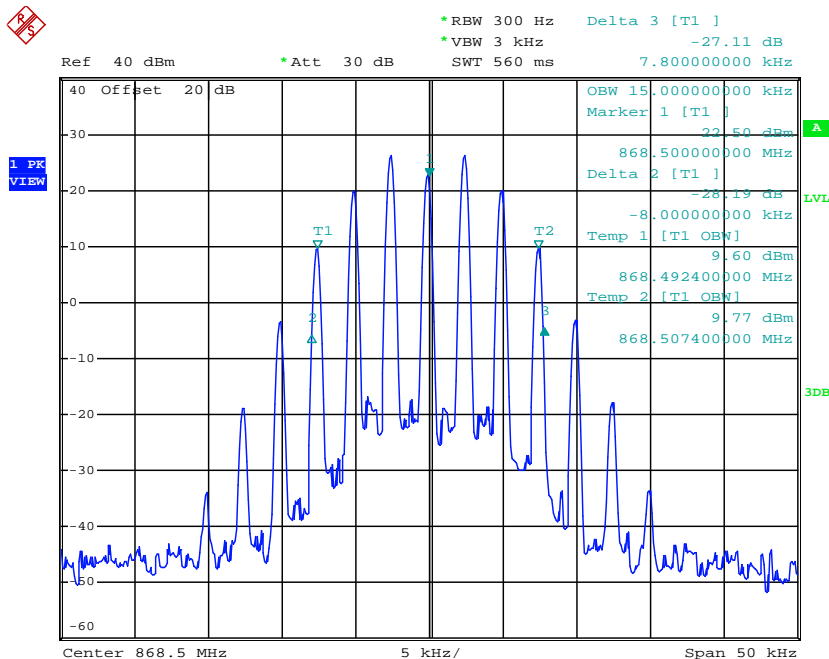

Date: 1.APR.2013 15:32:54

Modulation Type	Channel Separation	Freq.(MHz)	99% Bandwidth (KHz)	26dB Bandwidth (KHz)	FCC Limit (KHz)	Results
FM	12.5 KHz	806.5000	9.90	10.60	11.25	Compliance

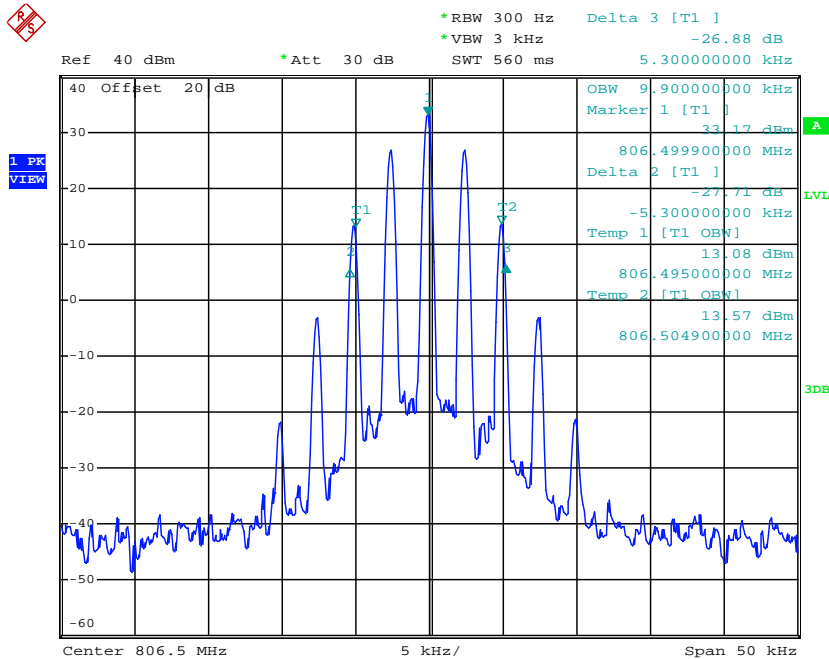

Date: 1.APR.2013 15:43:50

Modulation Type	Channel Separation	Freq.(MHz)	99% Bandwidth (KHz)	26dB Bandwidth (KHz)	FCC Limit (KHz)	Results
FM	12.5 KHz	817.0000	9.80	10.60	11.25	Compliance

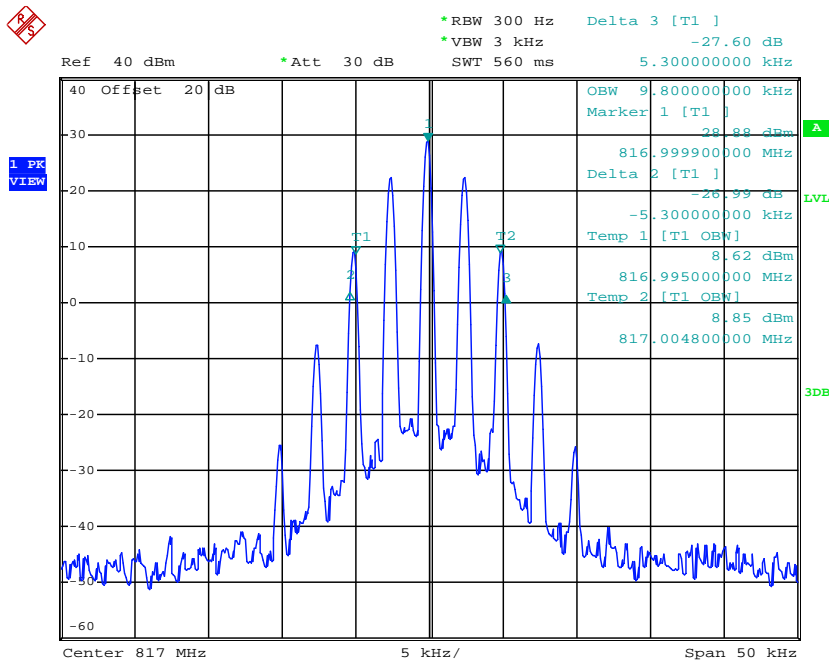

Date: 1.APR.2013 15:44:33

Modulation Type	Channel Separation	Freq.(MHz)	99% Bandwidth (KHz)	26dB Bandwidth (KHz)	FCC Limit (KHz)	Results
FM	12.5 KHz	823.5000	9.80	10.60	11.25	Compliance

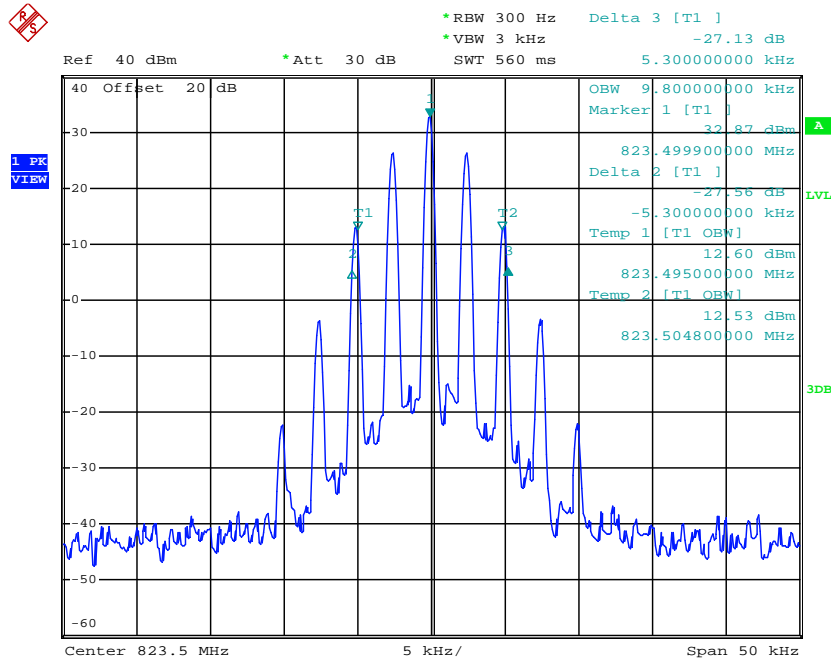

Date: 1.APR.2013 15:45:23

Modulation Type	Channel Separation	Freq.(MHz)	99% Bandwidth (KHz)	26dB Bandwidth (KHz)	FCC Limit (KHz)	Results
FM	12.5 KHz	851.5000	9.90	10.60	11.25	Compliance

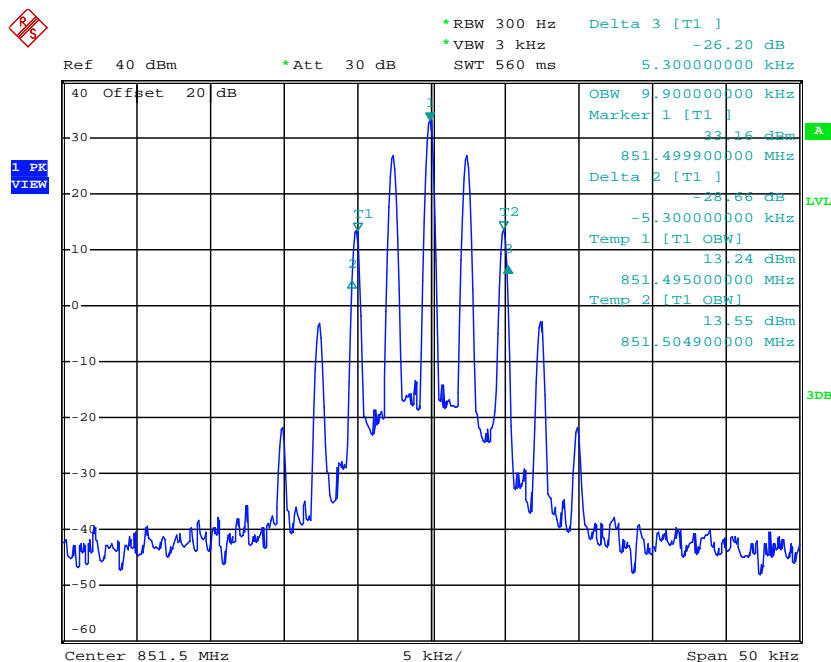

Date: 1.APR.2013 15:26:25

Modulation Type	Channel Separation	Freq.(MHz)	99% Bandwidth (KHz)	26dB Bandwidth (KHz)	FCC Limit (KHz)	Results
FM	12.5 KHz	860.0000	9.90	10.60	11.25	Compliance

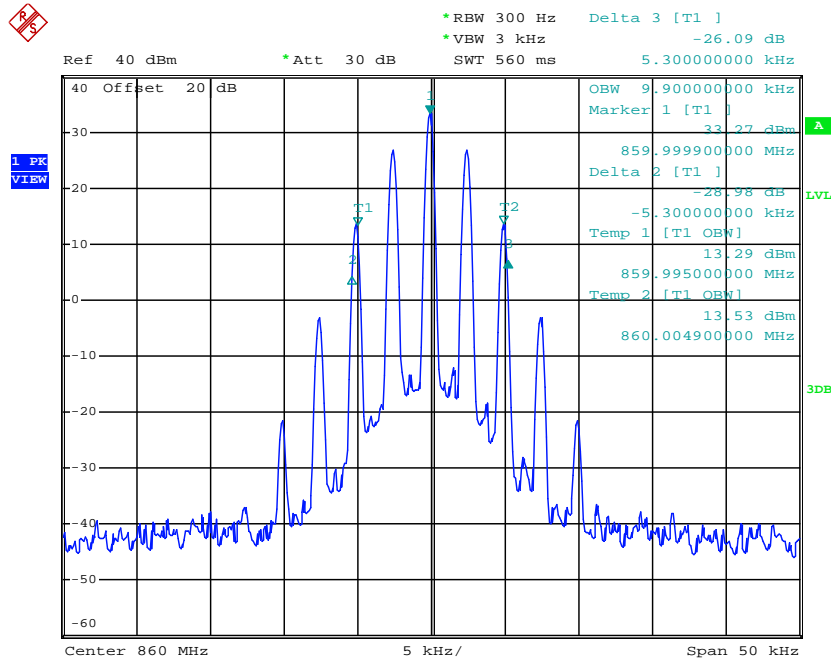

Date: 1.APR.2013 15:27:45

Modulation Type	Channel Separation	Freq.(MHz)	99% Bandwidth (KHz)	26dB Bandwidth (KHz)	FCC Limit (KHz)	Results
FM	12.5 KHz	868.5000	9.90	10.60	11.25	Compliance

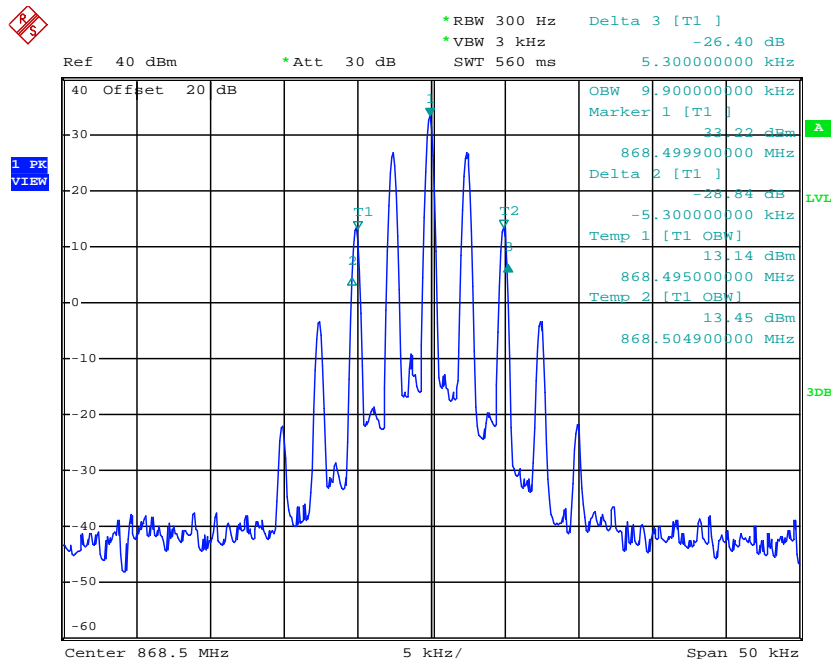

Date: 1.APR.2013 15:29:13

Modulation Type	Channel Separation	Freq.(MHz)	99% Bandwidth (KHz)	26dB Bandwidth (KHz)	FCC Limit (KHz)	Results
FM	12.5 KHz	896.5000	10.00	10.60	13.60	Compliance

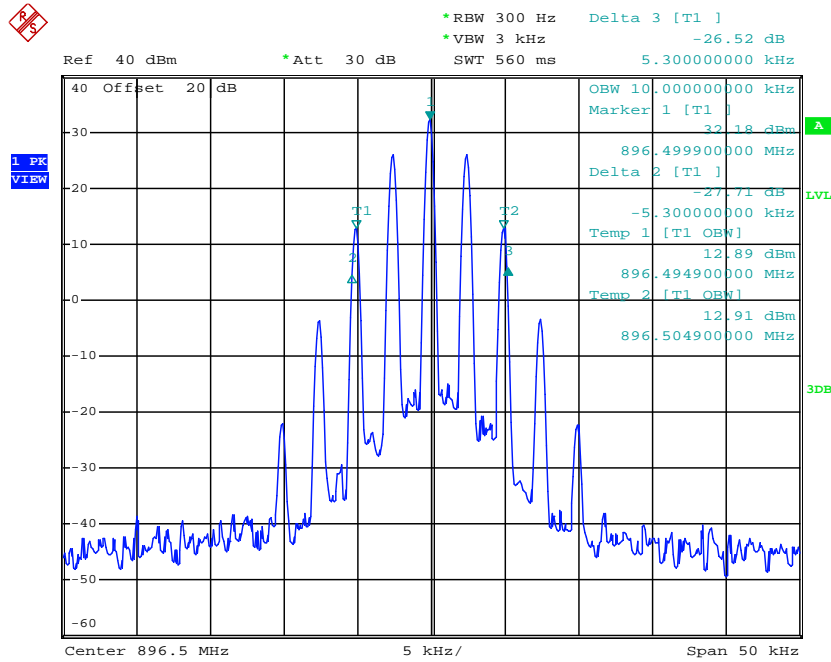

Date: 1.APR.2013 15:55:04

Modulation Type	Channel Separation	Freq.(MHz)	99% Bandwidth (KHz)	26dB Bandwidth (KHz)	FCC Limit (KHz)	Results
FM	12.5 KHz	900.5000	10.00	10.60	13.60	Compliance

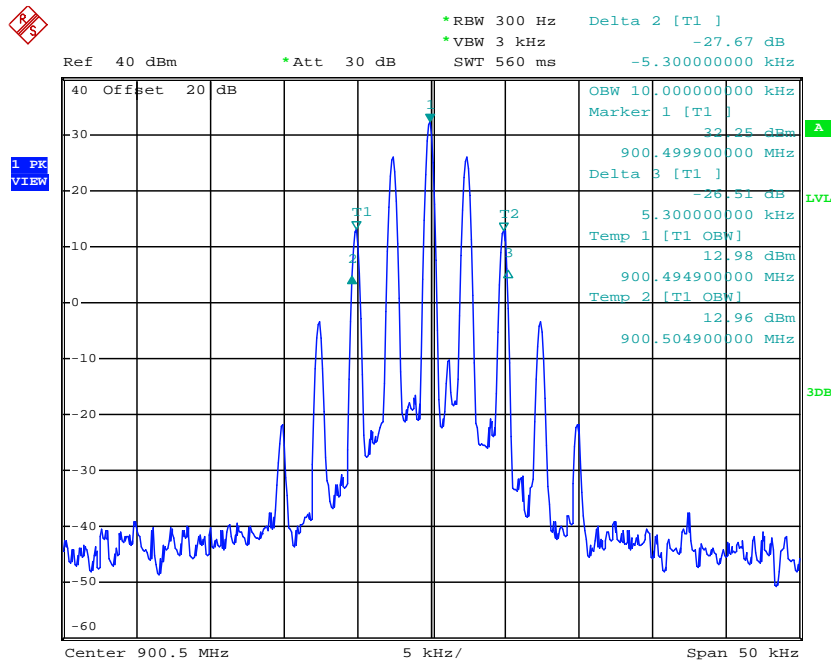

Date: 1.APR.2013 15:56:01

Modulation Type	Channel Separation	Freq.(MHz)	99% Bandwidth (KHz)	26dB Bandwidth (KHz)	FCC Limit (KHz)	Results
FM	12.5 KHz	935.5000	9.80	10.60	13.60	Compliance

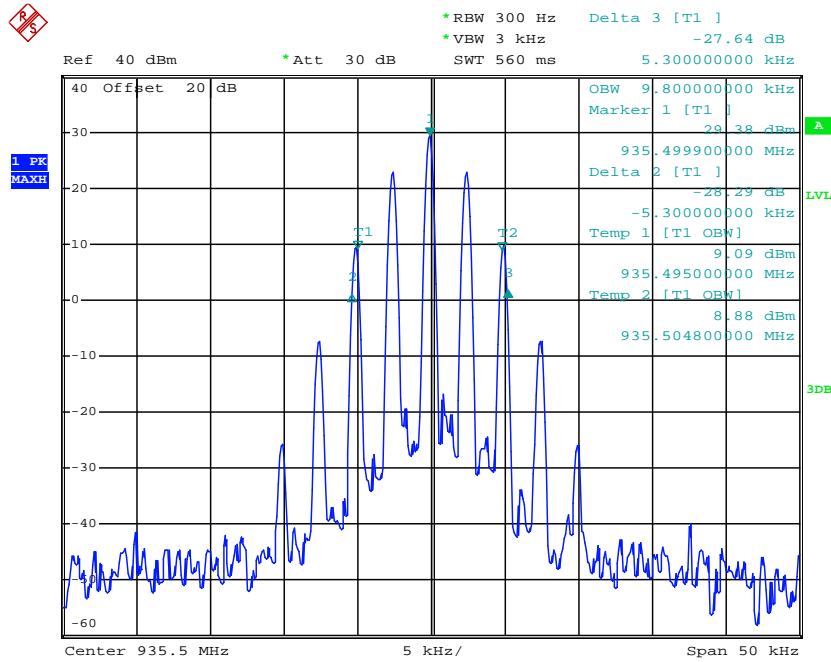

Date: 1.APR.2013 15:39:16

Modulation Type	Channel Separation	Freq.(MHz)	99% Bandwidth (KHz)	26dB Bandwidth (KHz)	FCC Limit (KHz)	Results
FM	12.5 KHz	939.5000	9.90	10.60	13.60	Compliance

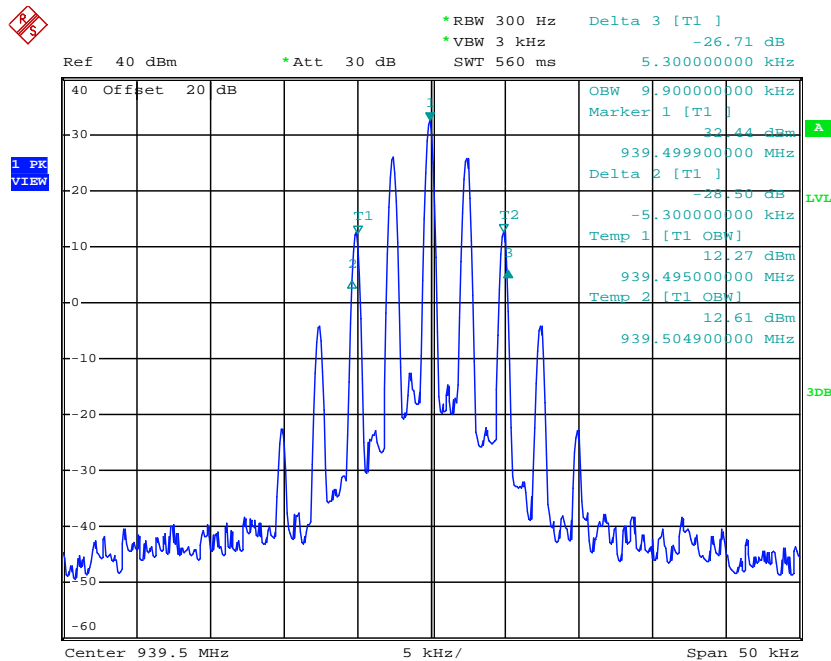

Date: 1.APR.2013 15:40:13

Modulation Type	Channel Separation	Freq.(MHz)	99% Bandwidth (KHz)	26dB Bandwidth (KHz)	FCC Limit (KHz)	Results
4FSK	12.5 KHz	806.5000	7.60	9.80	11.25	Compliance

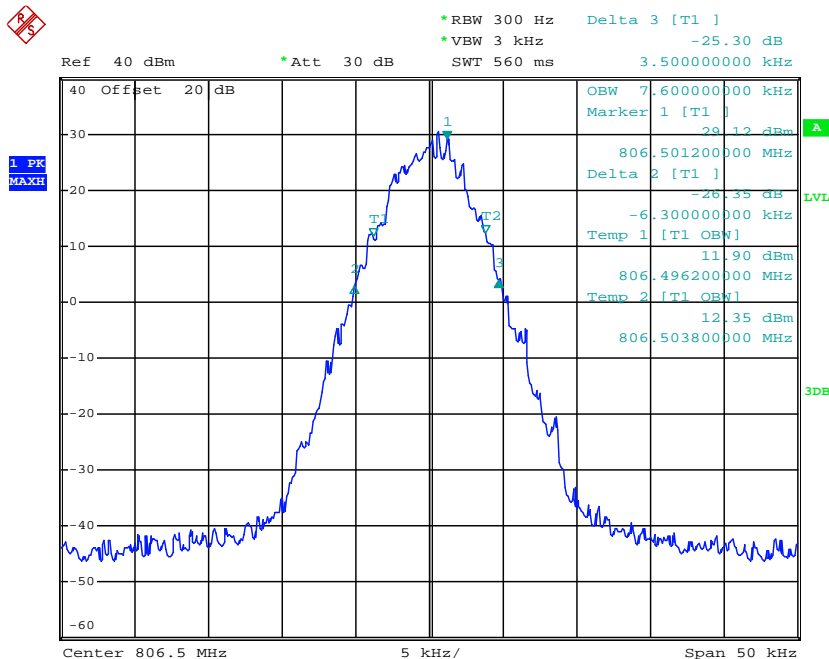

Date: 1.APR.2013 16:24:19

Modulation Type	Channel Separation	Freq.(MHz)	99% Bandwidth (KHz)	26dB Bandwidth (KHz)	FCC Limit (KHz)	Results
4FSK	12.5 KHz	817.0000	7.70	9.30	11.25	Compliance

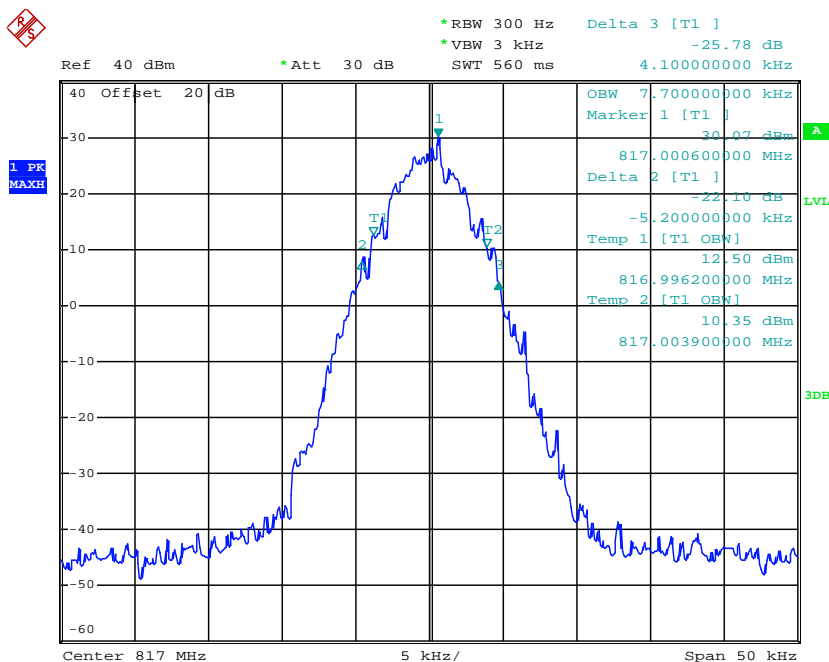

Date: 1.APR.2013 16:25:15

Modulation Type	Channel Separation	Freq.(MHz)	99% Bandwidth (KHz)	26dB Bandwidth (KHz)	FCC Limit (KHz)	Results
4FSK	12.5 KHz	823.5000	7.80	10.30	11.25	Compliance

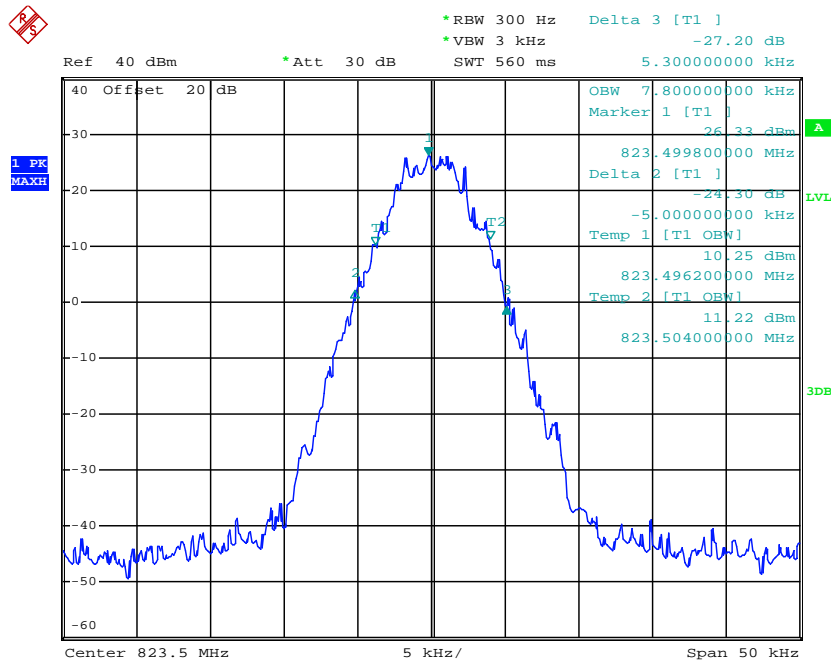

Date: 1.APR.2013 16:26:12

Modulation Type	Channel Separation	Freq.(MHz)	99% Bandwidth (KHz)	26dB Bandwidth (KHz)	FCC Limit (KHz)	Results
4FSK	12.5 KHz	851.5000	7.90	9.40	11.25	Compliance

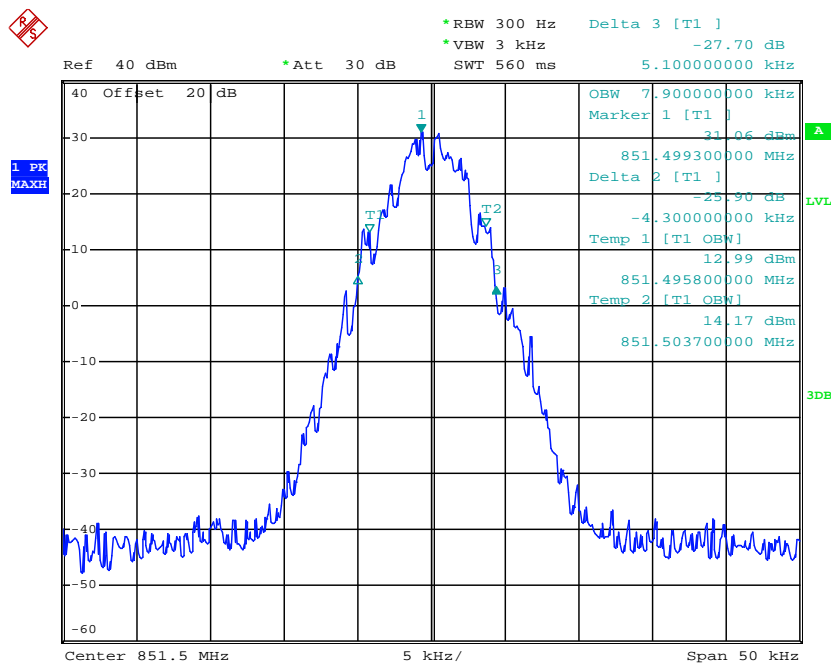

Date: 1.APR.2013 15:34:03

Modulation Type	Channel Separation	Freq.(MHz)	99% Bandwidth (KHz)	26dB Bandwidth (KHz)	FCC Limit (KHz)	Results
4FSK	12.5 KHz	860.0000	7.40	9.50	11.25	Compliance

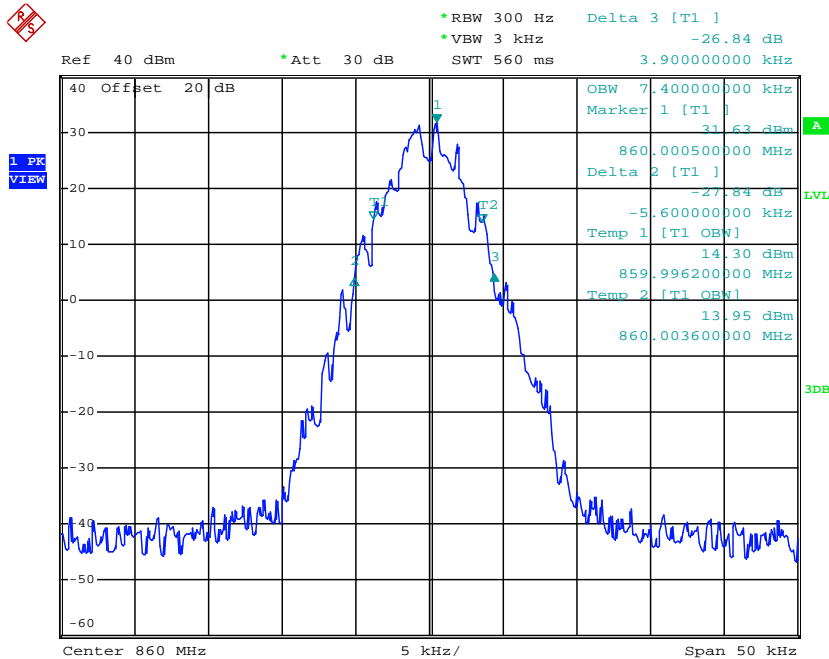

Date: 1.APR.2013 15:35:06

Modulation Type	Channel Separation	Freq.(MHz)	99% Bandwidth (KHz)	26dB Bandwidth (KHz)	FCC Limit (KHz)	Results
4FSK	12.5 KHz	868.5000	7.20	10.00	11.25	Compliance

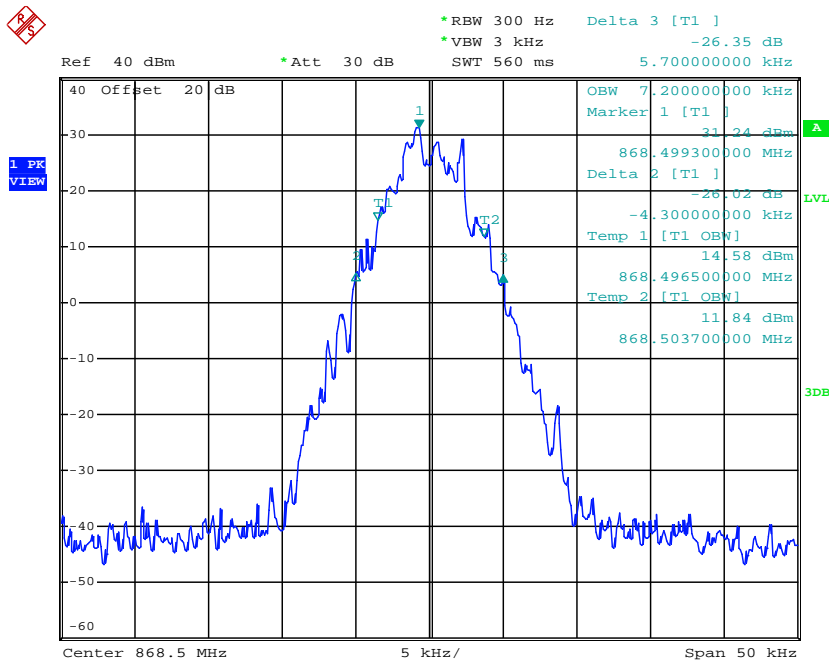

Date: 1.APR.2013 15:36:39

Modulation Type	Channel Separation	Freq.(MHz)	99% Bandwidth (KHz)	26dB Bandwidth (KHz)	FCC Limit (KHz)	Results
4FSK	12.5 KHz	896.5000	7.70	10.10	13.60	Compliance

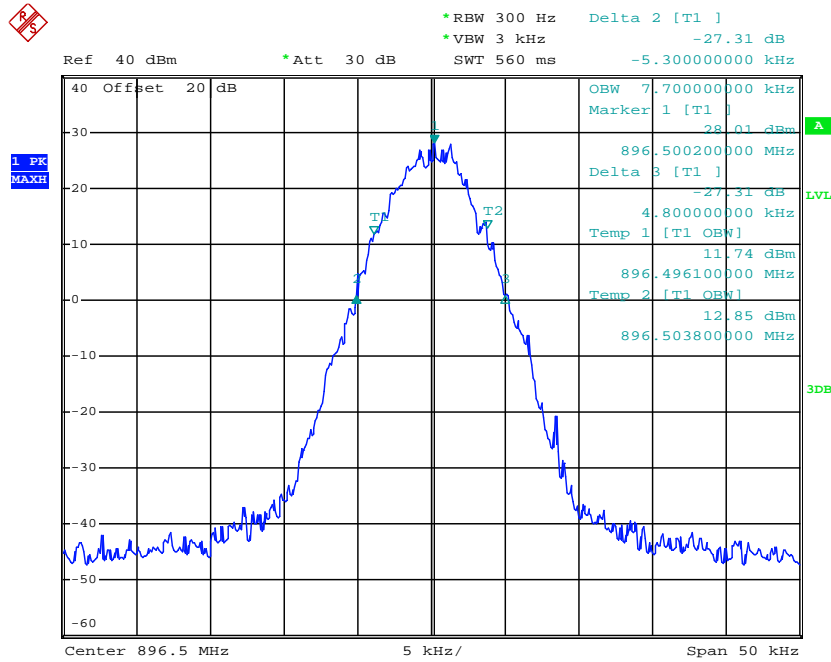

Date: 1.APR.2013 16:27:31

Modulation Type	Channel Separation	Freq.(MHz)	99% Bandwidth (KHz)	26dB Bandwidth (KHz)	FCC Limit (KHz)	Results
4FSK	12.5 KHz	900.5000	7.60	10.00	13.60	Compliance

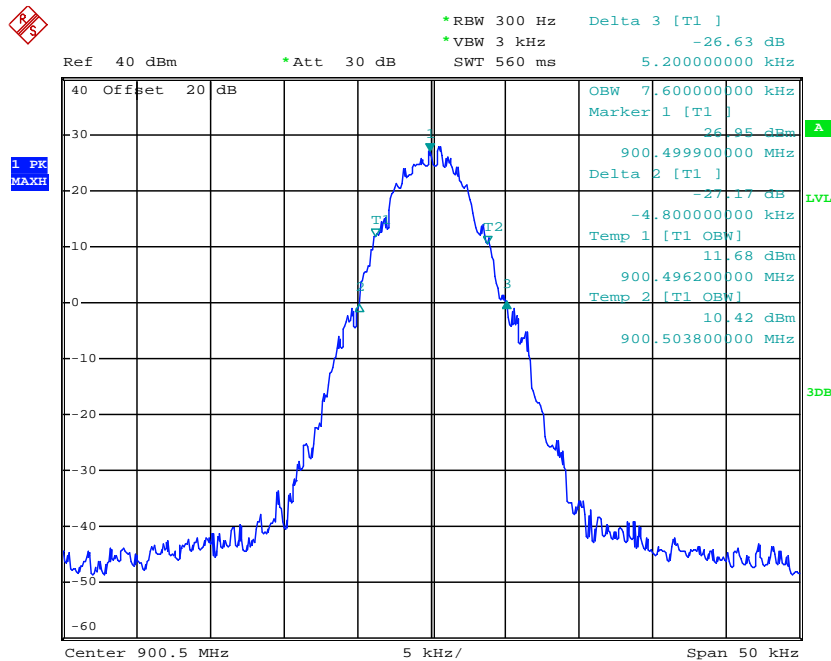

Date: 1.APR.2013 16:28:20

Modulation Type	Channel Separation	Freq.(MHz)	99% Bandwidth (KHz)	26dB Bandwidth (KHz)	FCC Limit (KHz)	Results
4FSK	12.5 KHz	935.5000	7.50	10.00	13.60	Compliance

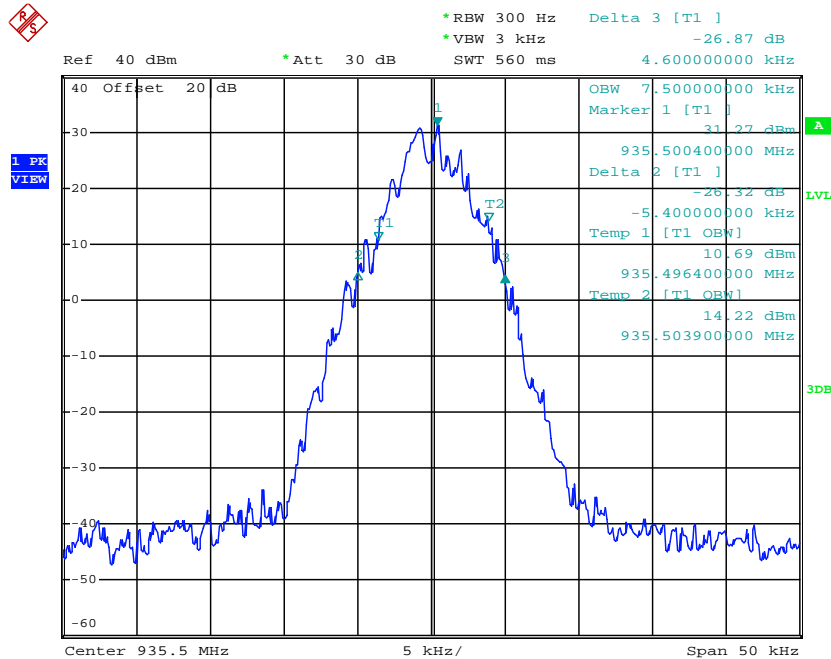

Date: 1.APR.2013 15:41:36

Modulation Type	Channel Separation	Freq.(MHz)	99% Bandwidth (KHz)	26dB Bandwidth (KHz)	FCC Limit (KHz)	Results
4FSK	12.5 KHz	939.5000	7.10	10.10	13.60	Compliance

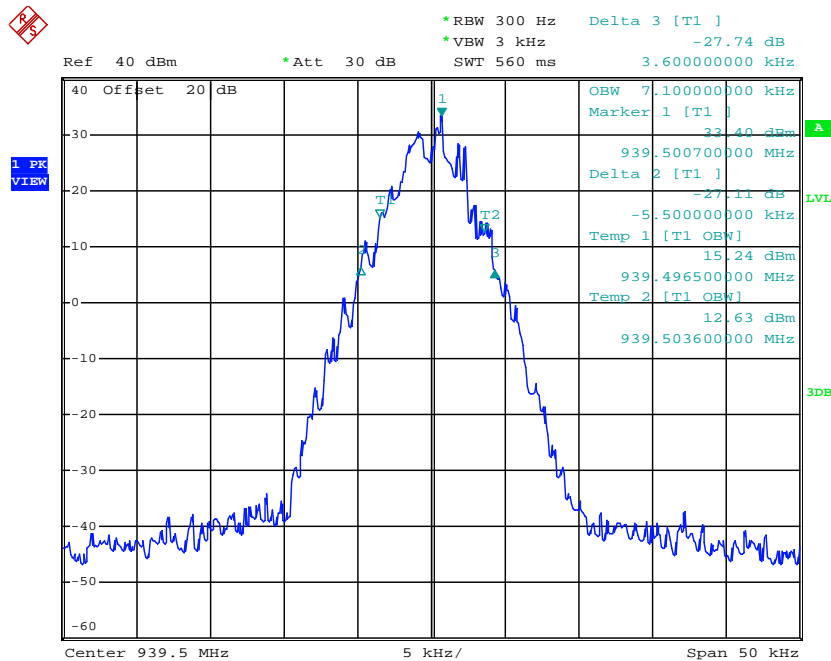

Date: 1.APR.2013 15:42:35

4.2.2 Emission Mask

Frequency Range (MHz)	Modulation Type	Channel Separation (KHz)	Test Channel	Test Frequency (MHz)	Applicable Mask	Remark	
806-825 ^[1]	Analog/FM	25	Low	806.5000	B	Both FCC and IC	
			Middle	817.0000	B		
			High	823.5000	B		
	Digital/4FSK	12.5	12.5	Low	806.5000	B and D	D only for IC B only for FCC
				Middle	817.0000	B and D	
				High	823.5000	B and D	
		12.5	12.5	Low	806.5000	B and D	
				Middle	817.0000	B and D	
				High	823.5000	B and D	
851-870 ^[1]	Analog/FM	25	Low	851.5000	B	Both FCC and IC	
			Middle	860.0000	B		
			High	868.5000	B		
	Digital/4FSK	12.5	12.5	Low	851.5000	B and D	D only for IC B only for FCC
				Middle	860.0000	B and D	
				High	868.5000	B and D	
		12.5	12.5	Low	851.5000	B and D	
				Middle	860.0000	B and D	
				High	868.5000	B and D	
896-902	Analog/FM	12.5	Low	896.5000	I	Both FCC and IC	
	Digital/4FSK		High	900.5000	I		
			Low	896.5000	I		
	High		900.5000	I			
935-941	Analog/FM	12.5	Low	935.5000	I	Both FCC and IC	
	Digital/4FSK		High	939.5000	I		
			Low	935.5000	I		
	High		939.5000	I			
Test Results			Compliance				

Remark:

[1]. Equipment used in this licensed to EA or non-EA systems shall comply with the emission mask provisions of §90.691.

Plots of Emission Mask Measurement

Referred as the attached plot hereinafter

**Note: The dark blue curve represents unmodulated signal.
The black curve represents modulated signal.**

For Both FCC and IC Review

Modulation Type	Channel Separation	Freq.(MHz)	FCC Applicable Mask	RBW	Audio Freq. (KHz)	Results
FM	25 KHz	806.5000	B	300Hz	2.5	Compliance

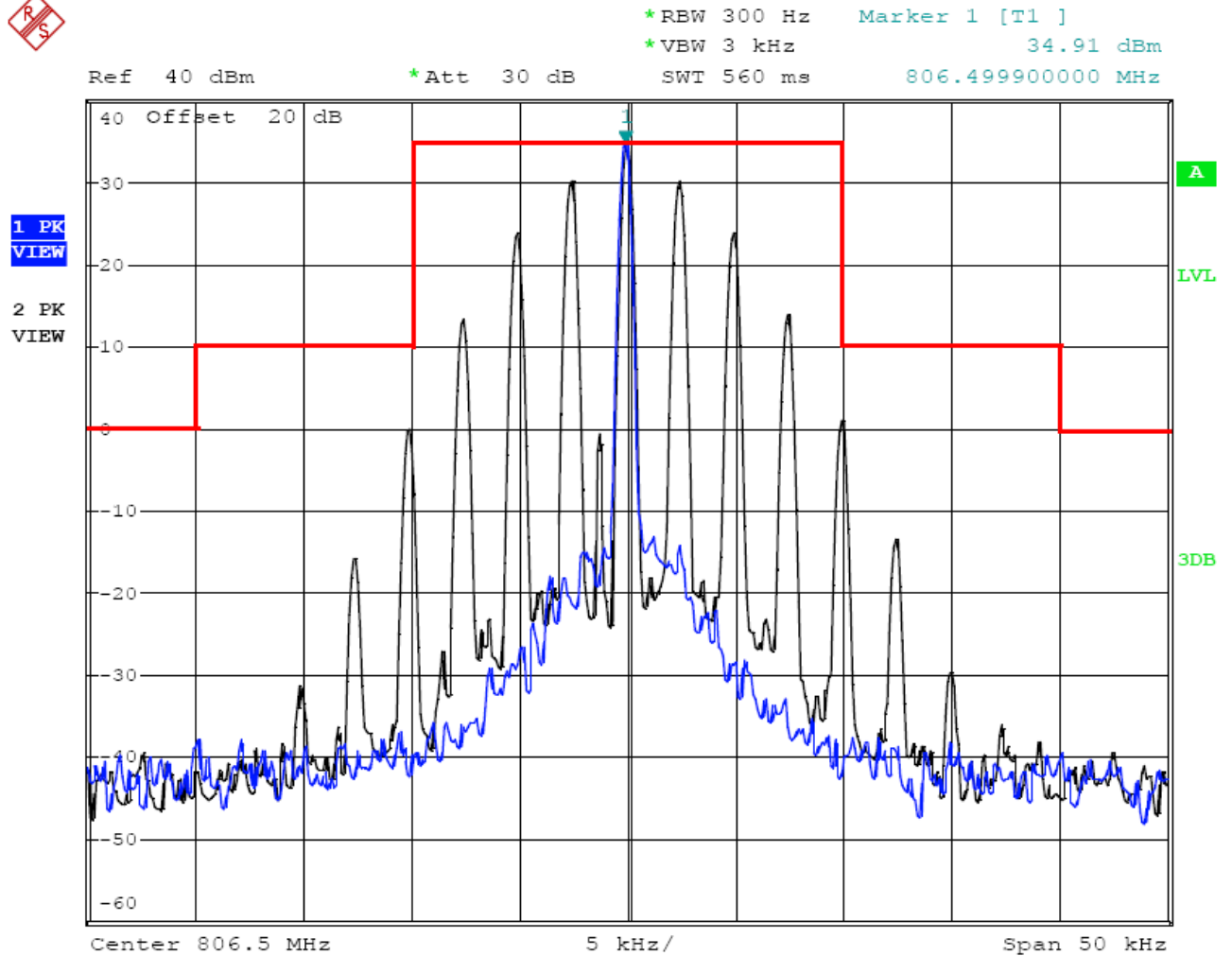

Date: 1.APR.2013 17:53:36

25 kHz Channel Spacing, 806.5000 MHz, 2500 Hz Audio Modulation Only

Modulation Type	Channel Separation	Freq.(MHz)	FCC Applicable Mask	RBW	Audio Freq. (KHz)	Results
FM	25 KHz	851.5000	B	300Hz	2.5	Compliance

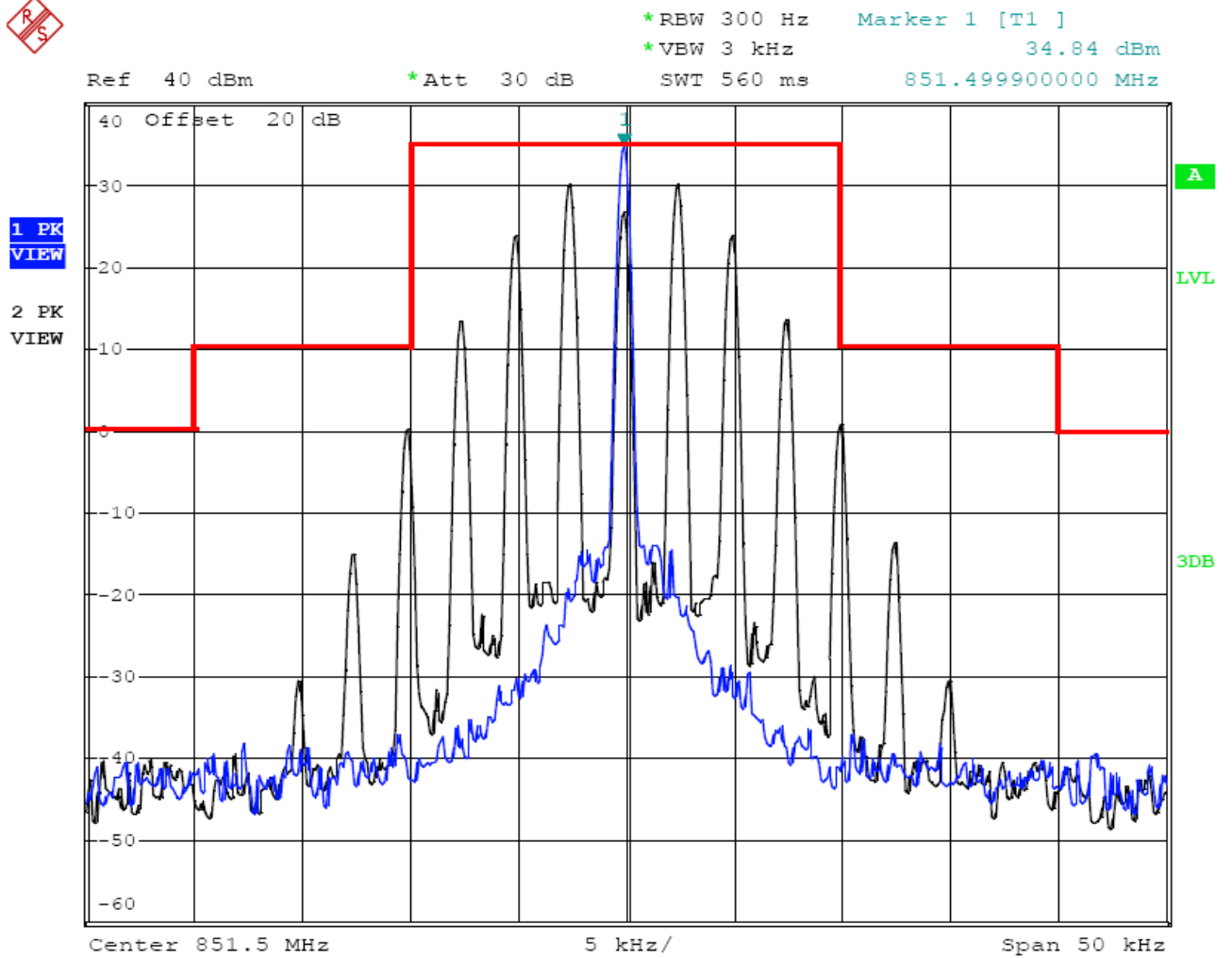

Date: 1.APR.2013 17:29:20

25 kHz Channel Spacing, 851.5000 MHz, 2500 Hz Audio Modulation Only

Only for FCC Review

Modulation Type	Channel Separation	Freq.(MHz)	FCC Applicable Mask	RBW	Audio Freq. (KHz)	Results
FM	12.5 KHz	806.5000	B	300Hz	2.5	Compliance

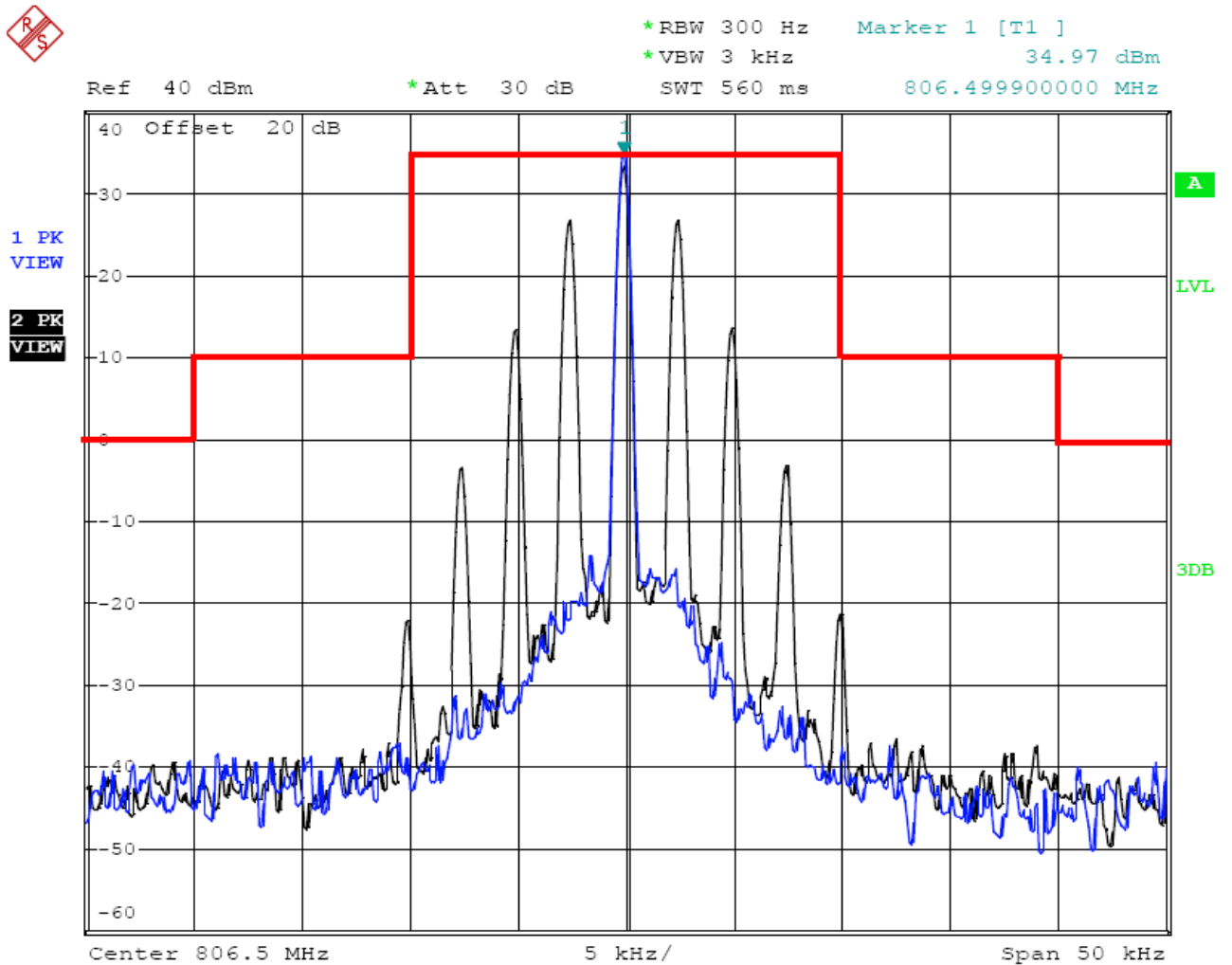

Date: 1.APR.2013 17:34:47

12.5 kHz Channel Spacing, 806.5000 MHz, 2500 Hz Audio Modulation Only

Modulation Type	Channel Separation	Freq.(MHz)	FCC Applicable Mask	RBW	Audio Freq. (KHz)	Results
FM	12.5 KHz	817.0000	B	300Hz	2.5	Compliance

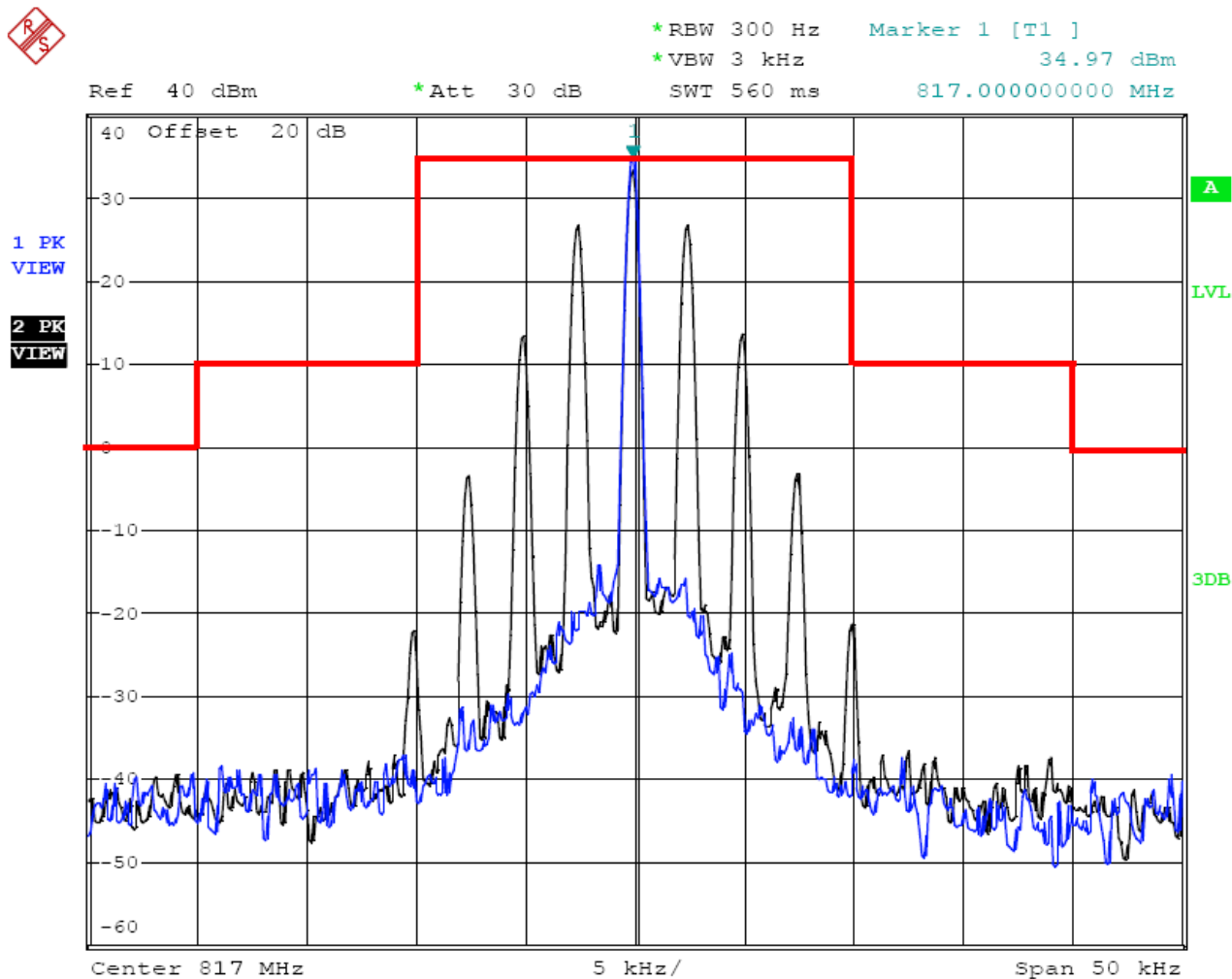

Date: 1.APR.2013 17:34:47

12.5 kHz Channel Spacing, 817.0000 MHz, 2500 Hz Audio Modulation Only

Modulation Type	Channel Separation	Freq.(MHz)	FCC Applicable Mask	RBW	Audio Freq. (KHz)	Results
FM	12.5 KHz	823.5000	B	300Hz	2.5	Compliance

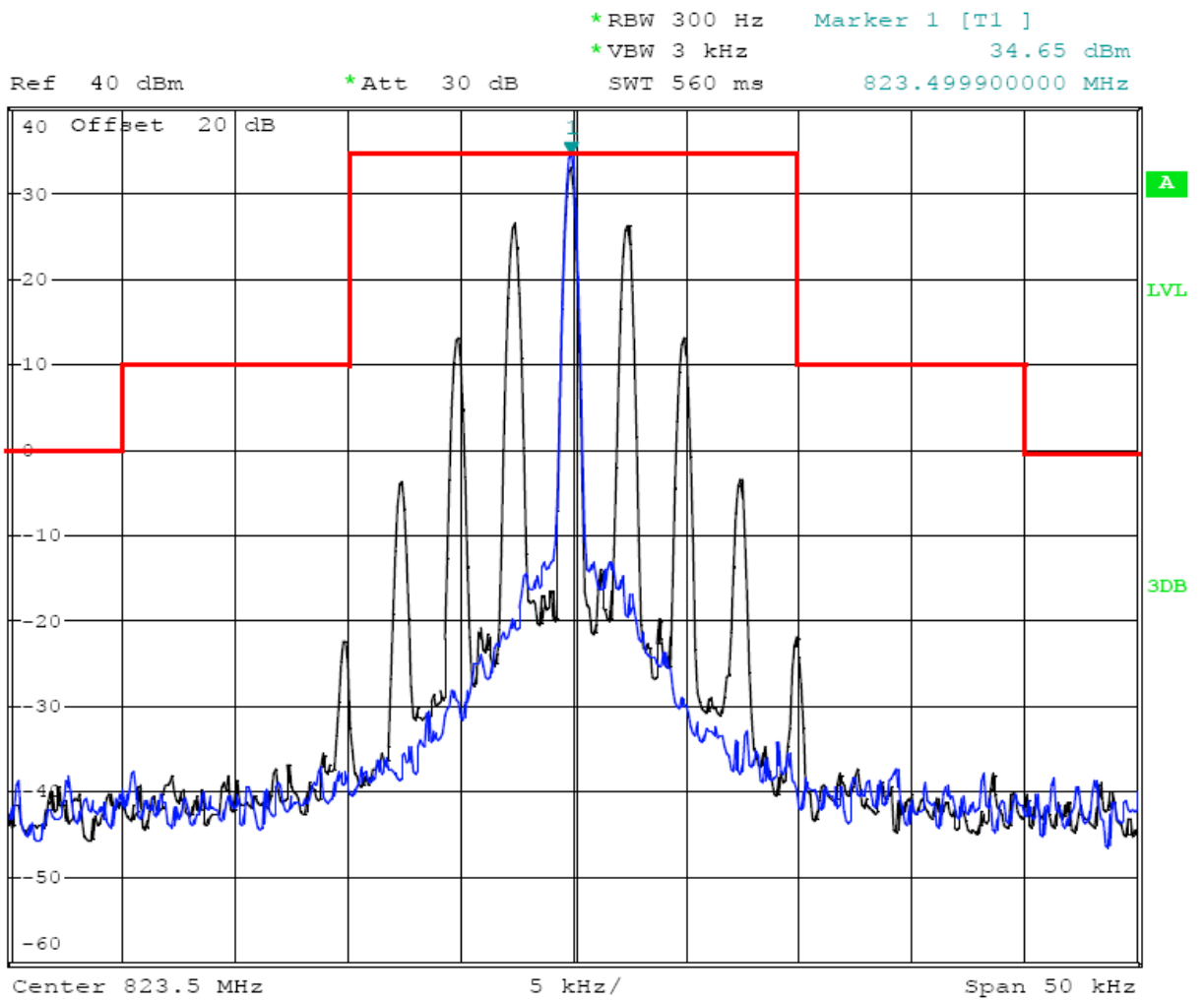

Date: 1.APR.2013 17:43:02

12.5 kHz Channel Spacing, 823.5000 MHz, 2500 Hz Audio Modulation Only

Modulation Type	Channel Separation	Freq.(MHz)	FCC Applicable Mask	RBW	Audio Freq. (KHz)	Results
FM	12.5 KHz	851.5000	B	300Hz	2.5	Compliance

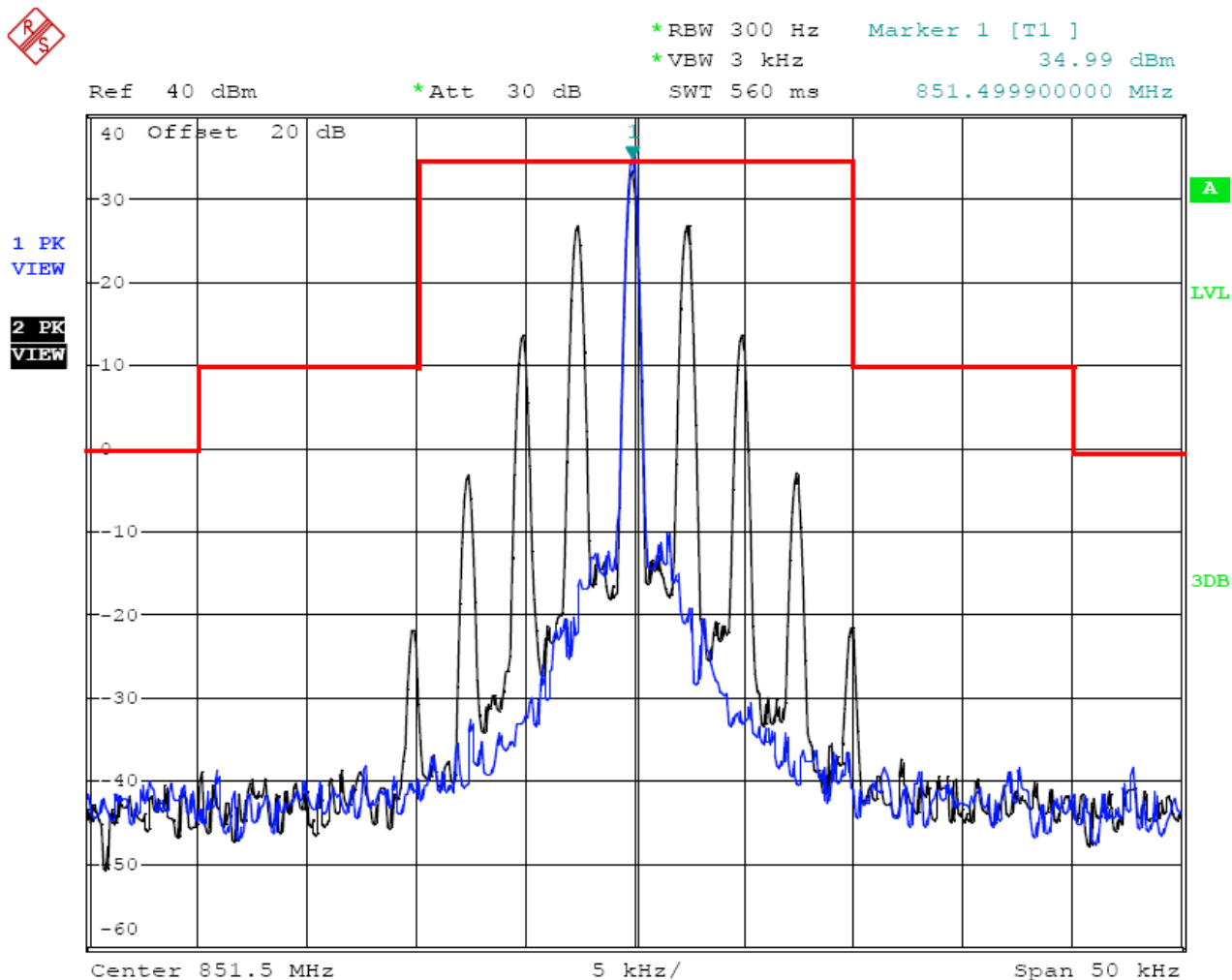

Date: 1.APR.2013 17:20:05

12.5 kHz Channel Spacing, 851.5000 MHz, 2500 Hz Audio Modulation Only

Modulation Type	Channel Separation	Freq.(MHz)	FCC Applicable Mask	RBW	Audio Freq. (KHz)	Results
FM	12.5 KHz	860.0000	B	300Hz	2.5	Compliance

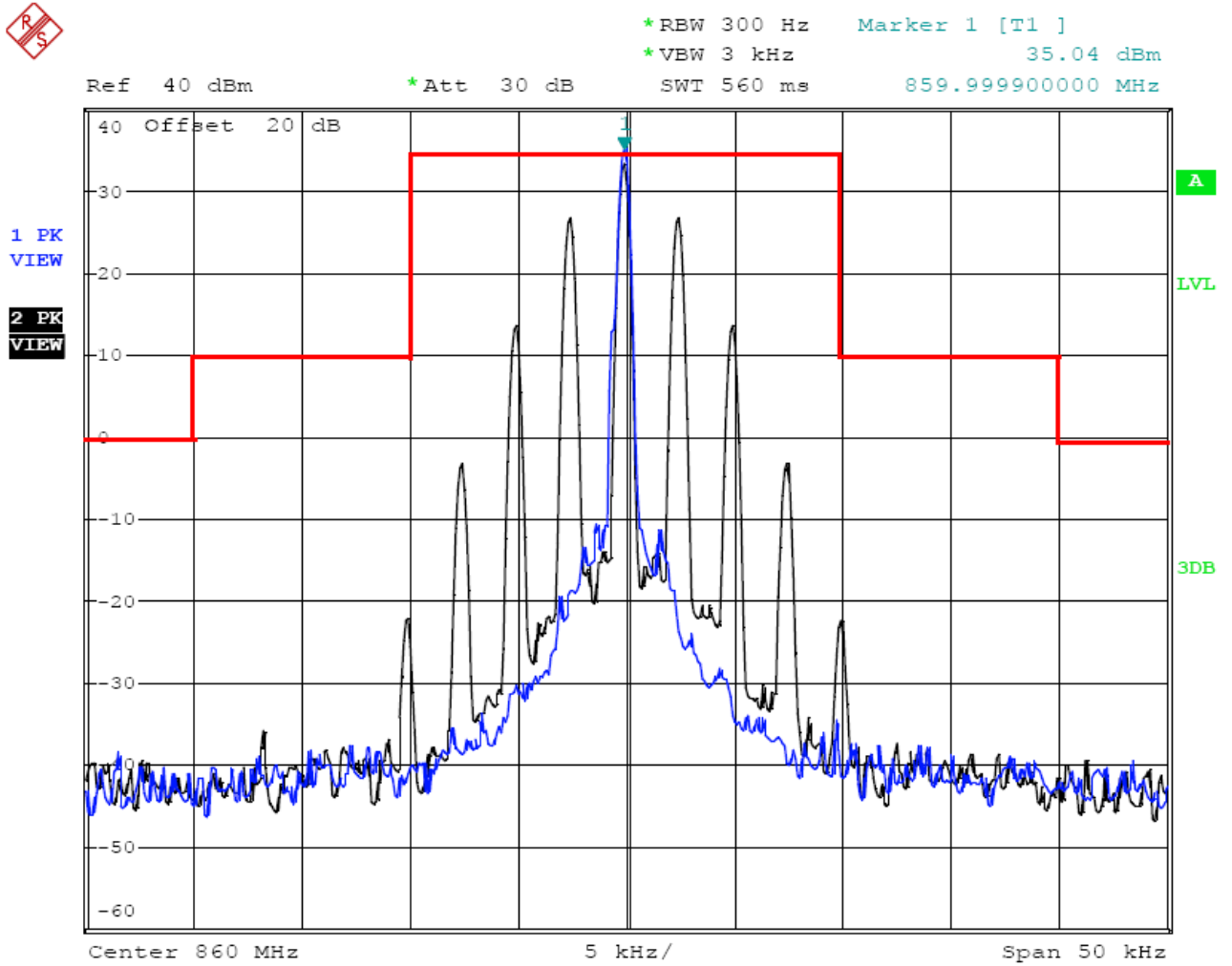

Date: 1.APR.2013 17:21:22

12.5 kHz Channel Spacing, 860.0000 MHz, 2500 Hz Audio Modulation Only

Modulation Type	Channel Separation	Freq.(MHz)	FCC Applicable Mask	RBW	Audio Freq. (KHz)	Results
FM	12.5 KHz	868.5000	B	300Hz	2.5	Compliance

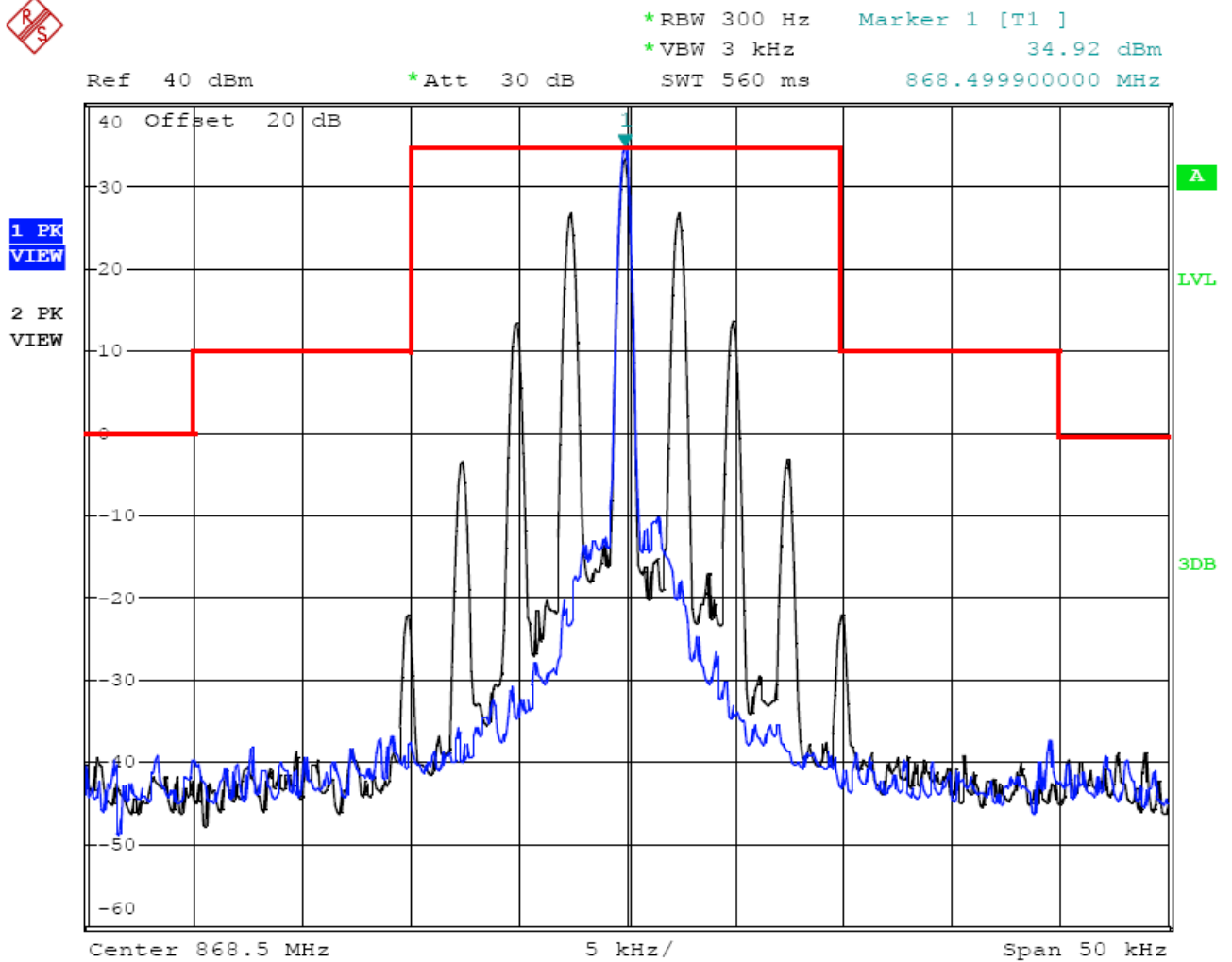

Date: 1.APR.2013 17:22:19

12.5 kHz Channel Spacing, 868.5000 MHz, 2500 Hz Audio Modulation Only

For Both FCC and IC Review

Modulation Type	Channel Separation	Freq.(MHz)	FCC Applicable Mask	RBW	Audio Freq. (KHz)	Results
FM	12.5 KHz	896.5000	I	300Hz	2.5	Compliance

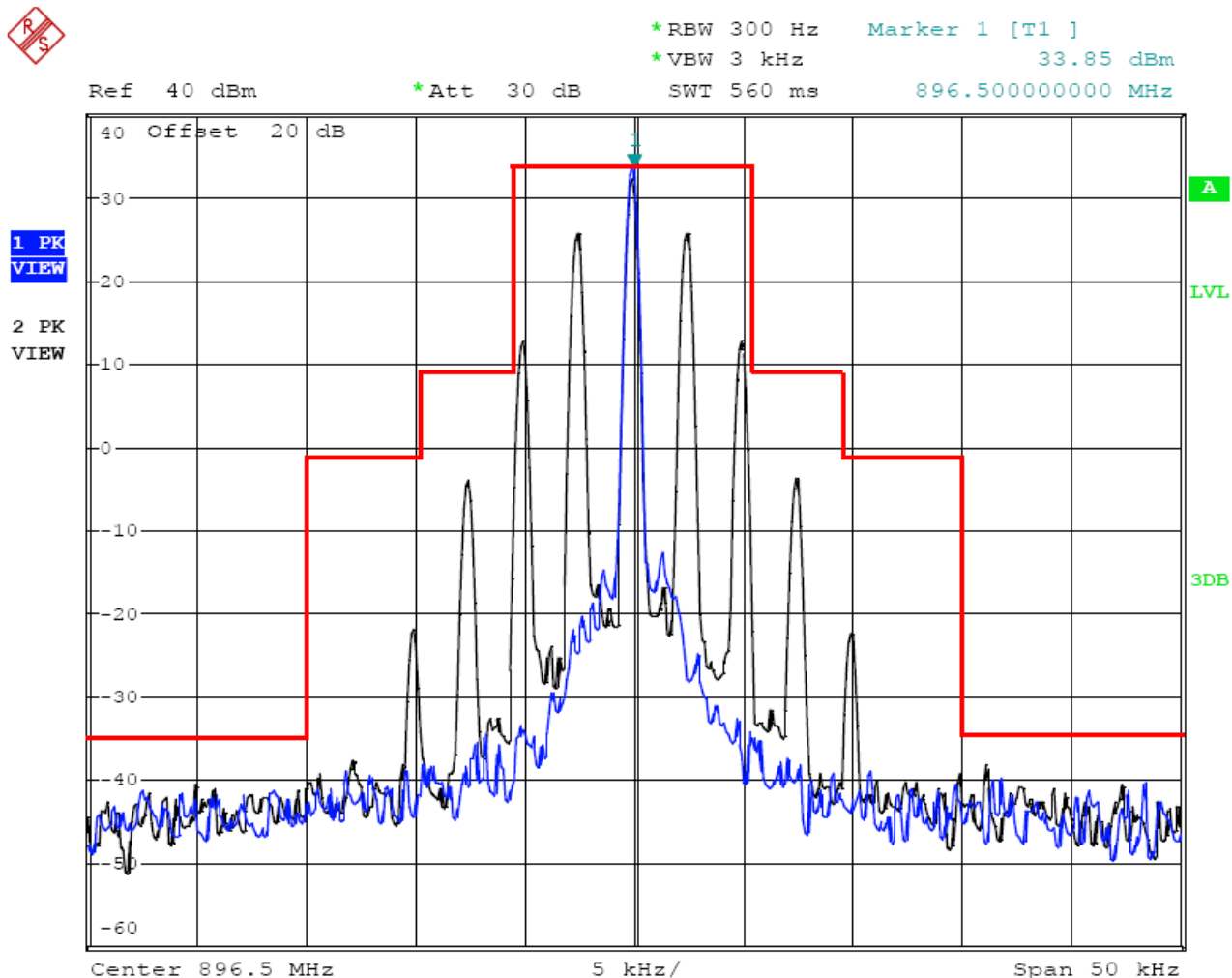

Date: 1.APR.2013 17:50:16

12.5 kHz Channel Spacing, 868.5000 MHz, 2500 Hz Audio Modulation Only

Modulation Type	Channel Separation	Freq.(MHz)	FCC Applicable Mask	RBW	Audio Freq. (KHz)	Results
FM	12.5 KHz	900.5000	I	300Hz	2.5	Compliance



Ref 40 dBm *Att 30 dB SWT 560 ms 900.500000000 MHz
*RBW 300 Hz Marker 1 [T1] 34.02 dBm
*VBW 3 kHz

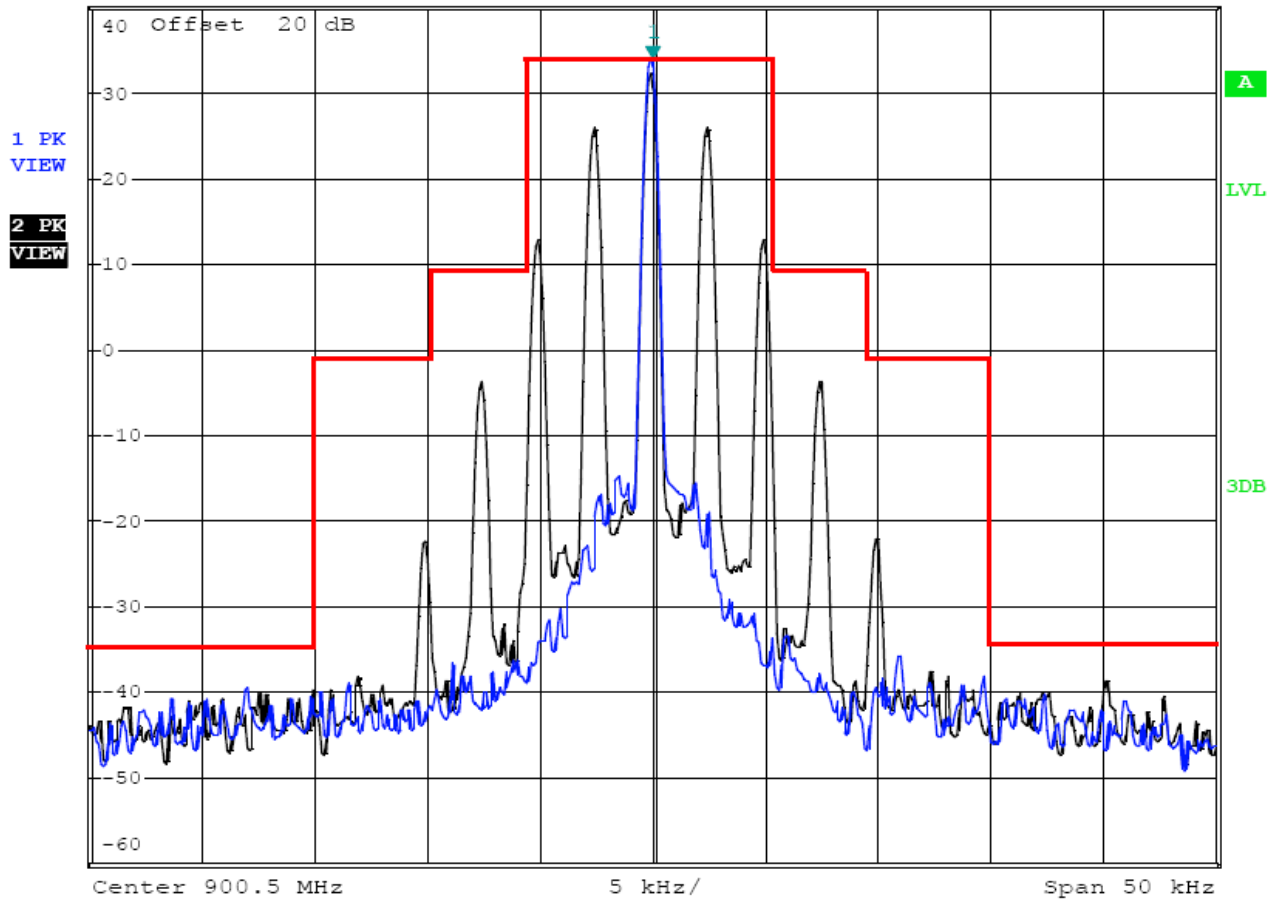

Date: 1.APR.2013 17:51:06

12.5 kHz Channel Spacing, 900.5000 MHz, 2500 Hz Audio Modulation Only

Modulation Type	Channel Separation	Freq.(MHz)	FCC Applicable Mask	RBW	Audio Freq. (KHz)	Results
FM	12.5 KHz	935.5000	I	300Hz	2.5	Compliance

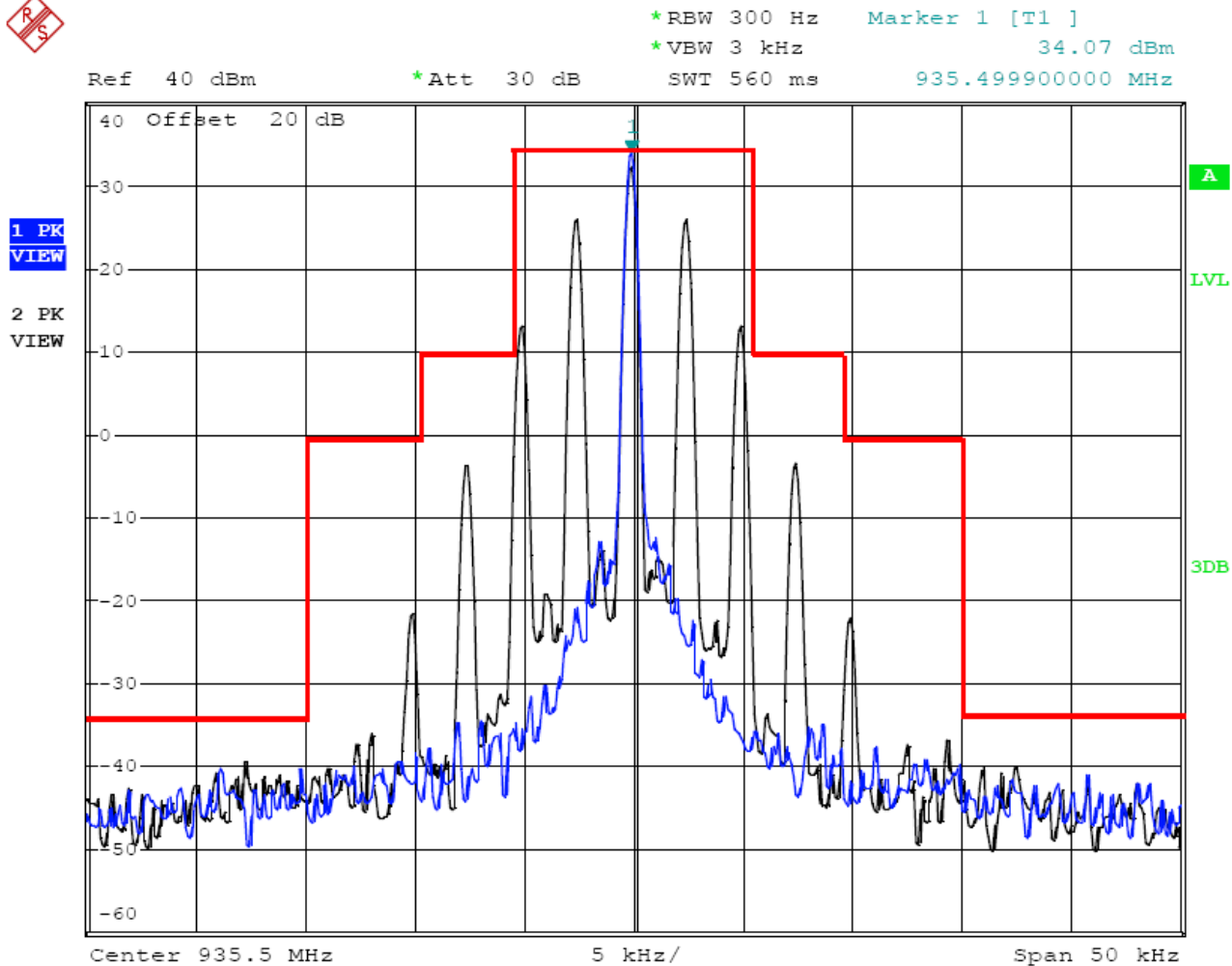

Date: 1.APR.2013 17:27:08

12.5 kHz Channel Spacing, 935.5000 MHz, 2500 Hz Audio Modulation Only

Modulation Type	Channel Separation	Freq.(MHz)	FCC Applicable Mask	RBW	Audio Freq. (KHz)	Results
FM	12.5 KHz	939.5000	I	300Hz	2.5	Compliance



Ref 40 dBm *Att 30 dB SWT 560 ms Marker 1 [T1] 34.04 dBm
*RBW 300 Hz *VBW 3 kHz 939.499900000 MHz

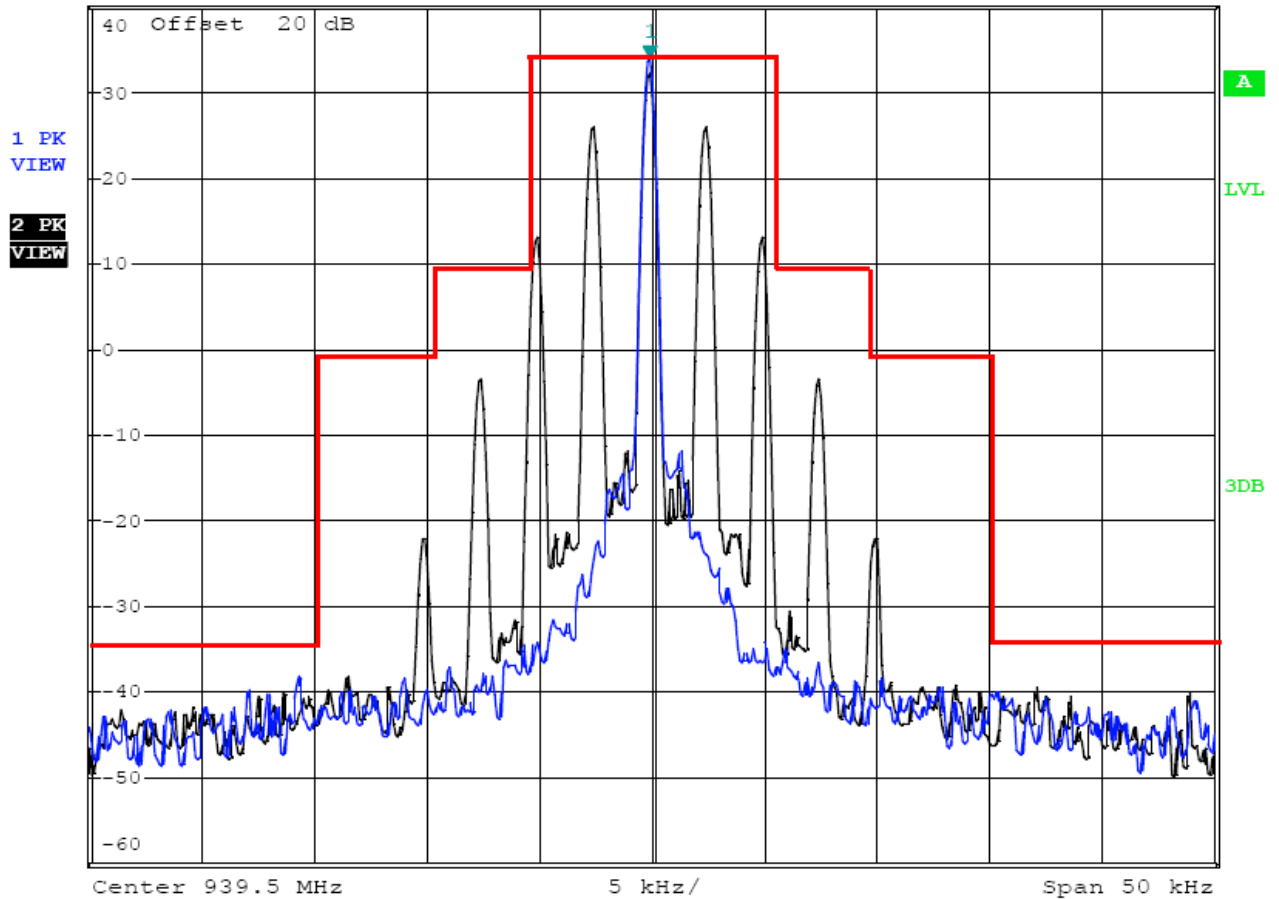

Date: 1.APR.2013 17:28:20

12.5 kHz Channel Spacing, 939.5000 MHz, 2500 Hz Audio Modulation Only

Only for FCC Review

Modulation Type	Channel Separation	Freq.(MHz)	FCC Applicable Mask	RBW	Audio Freq. (KHz)	Results
4FSK	12.5 KHz	806.5000	B	300Hz	2.5	Complicance

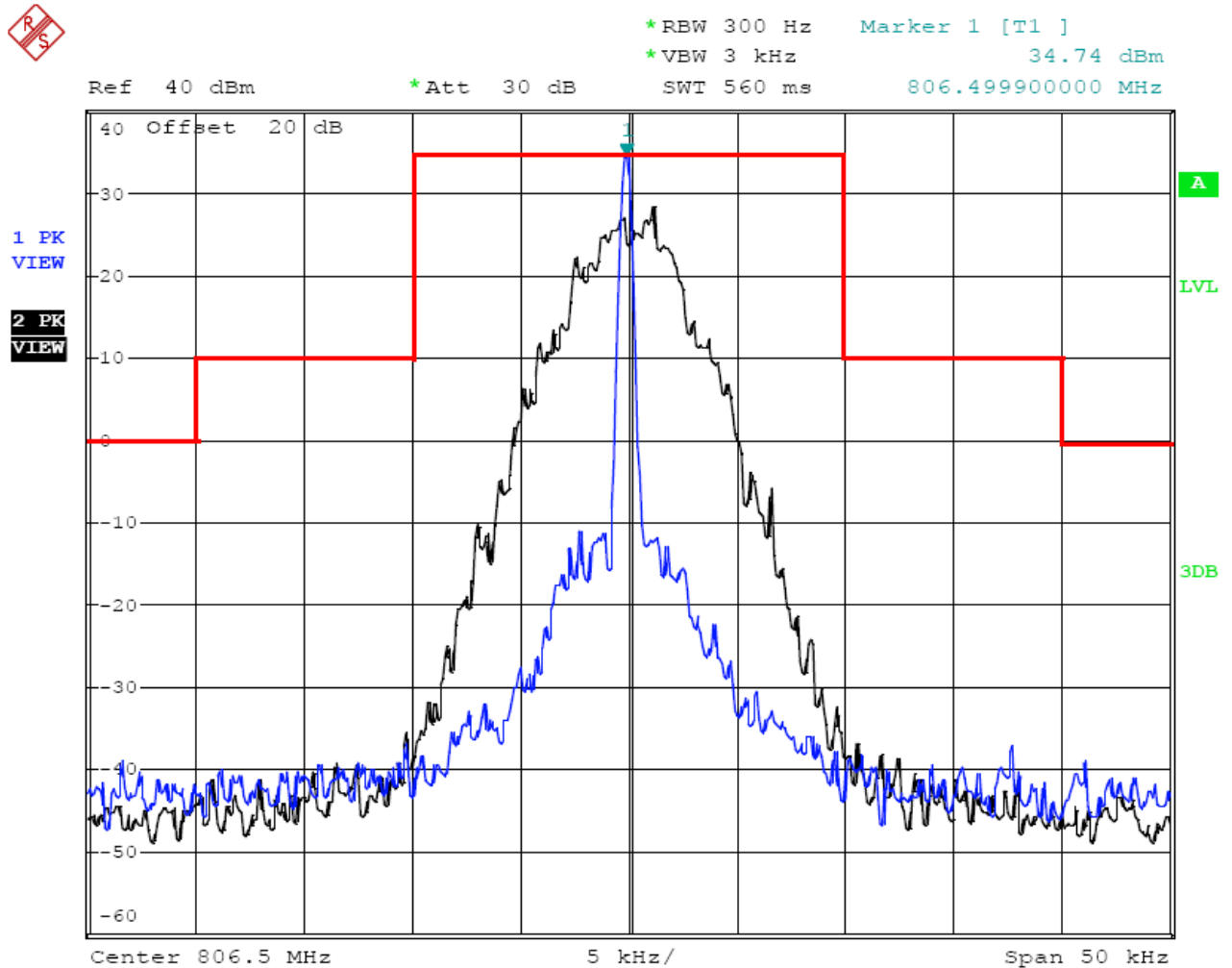

Date: 1.APR.2013 16:43:05

12.5 kHz Channel Spacing, 806.5000 MHz, 4FSK Modulation Only

Modulation Type	Channel Separation	Freq.(MHz)	FCC Applicable Mask	RBW	Audio Freq. (KHz)	Results
4FSK	12.5 KHz	817.0000	B	300Hz	/	Compliance

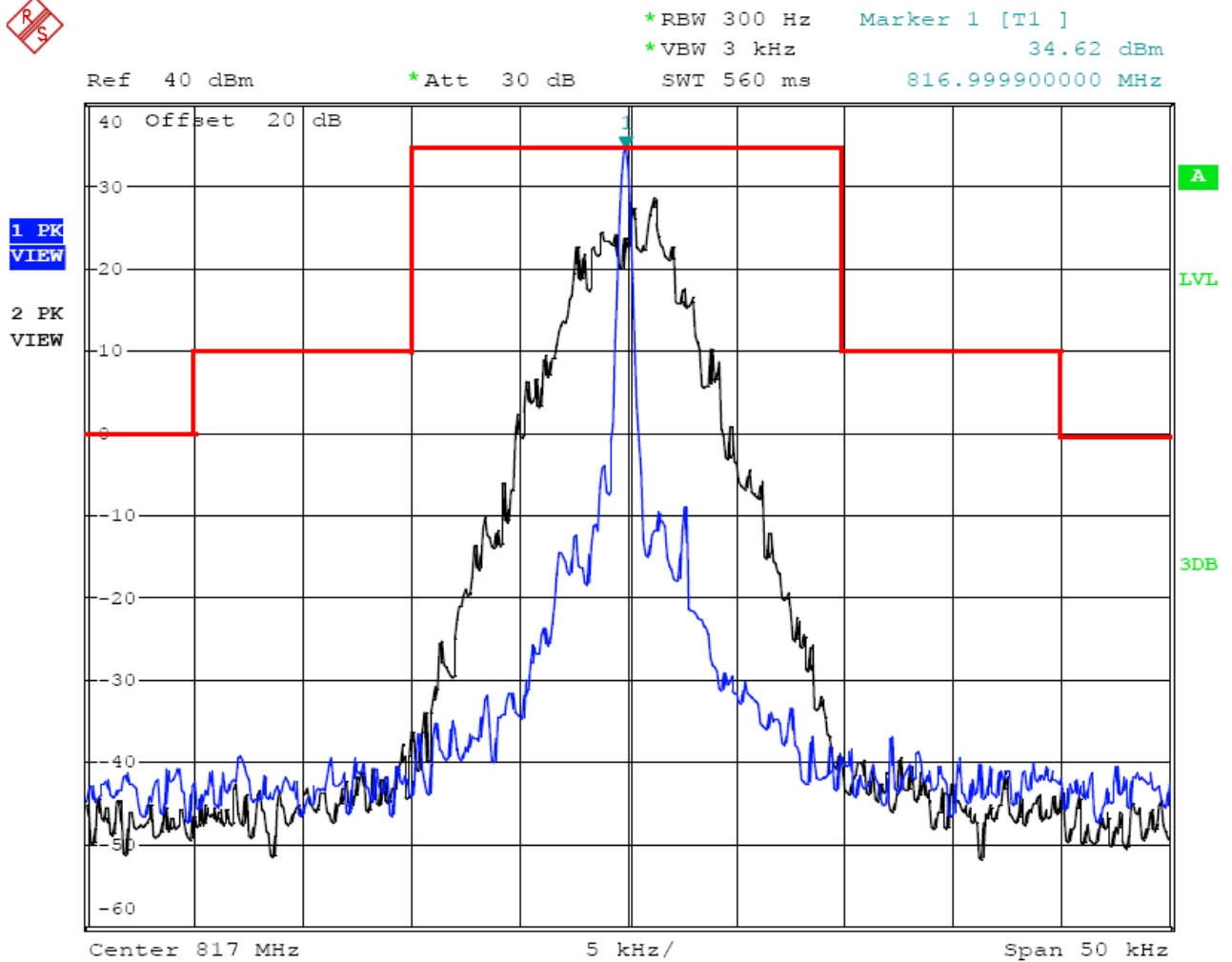

Date: 1.APR.2013 16:50:14

12.5 kHz Channel Spacing, 817.0000 MHz, 4FSK Modulation Only

Modulation Type	Channel Separation	Freq.(MHz)	FCC Applicable Mask	RBW	Audio Freq. (KHz)	Results
4FSK	12.5 KHz	823.5000	B	300Hz	/	Compliance

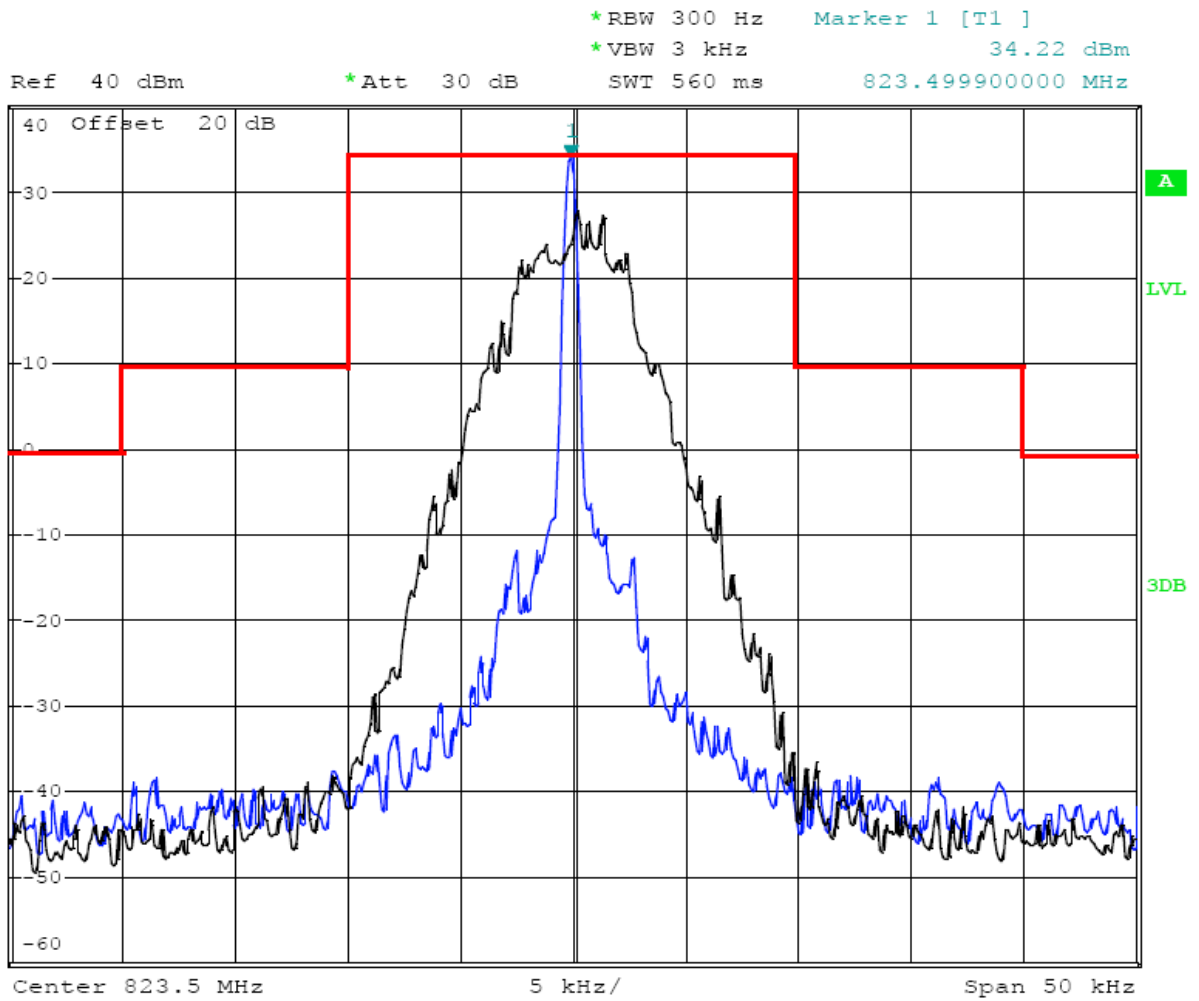

Date: 1.APR.2013 16:51:47

12.5 kHz Channel Spacing, 823.5000 MHz, 4FSK Modulation Only

Modulation Type	Channel Separation	Freq.(MHz)	FCC Applicable Mask	RBW	Audio Freq. (KHz)	Results
4FSK	12.5 KHz	860.0000	B	300Hz	/	Compliance

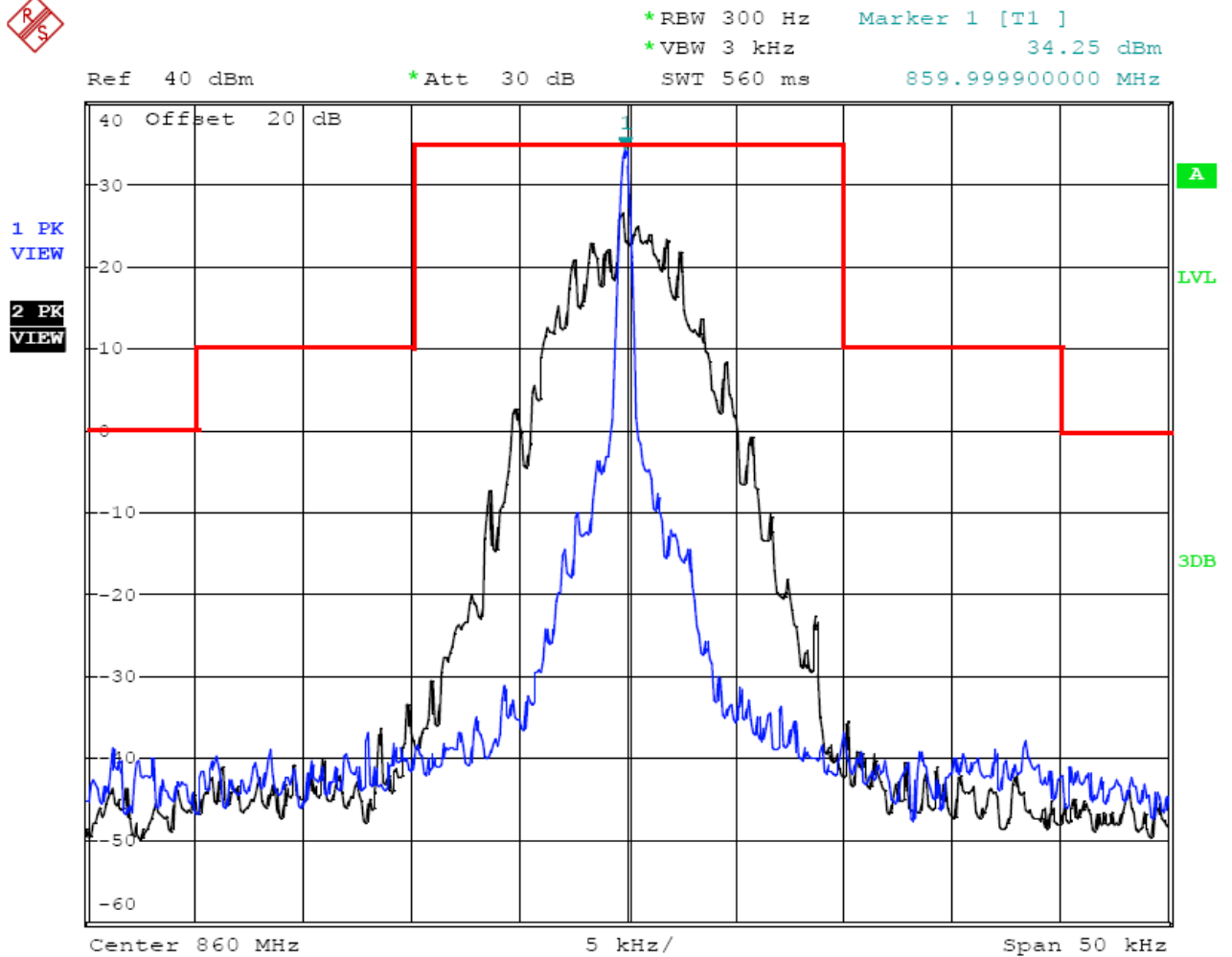

Date: 1.APR.2013 17:04:55

12.5 kHz Channel Spacing, 860.0000 MHz, 4FSK Modulation Only

Modulation Type	Channel Separation	Freq.(MHz)	FCC Applicable Mask	RBW	Audio Freq. (KHz)	Results
4FSK	12.5 KHz	868.5000	B	300Hz	/	Compliance



Ref 40 dBm *Att 30 dB *RBW 300 Hz Marker 1 [T1]
 *VBW 3 kHz 34.23 dBm
 SWT 560 ms 868.499900000 MHz

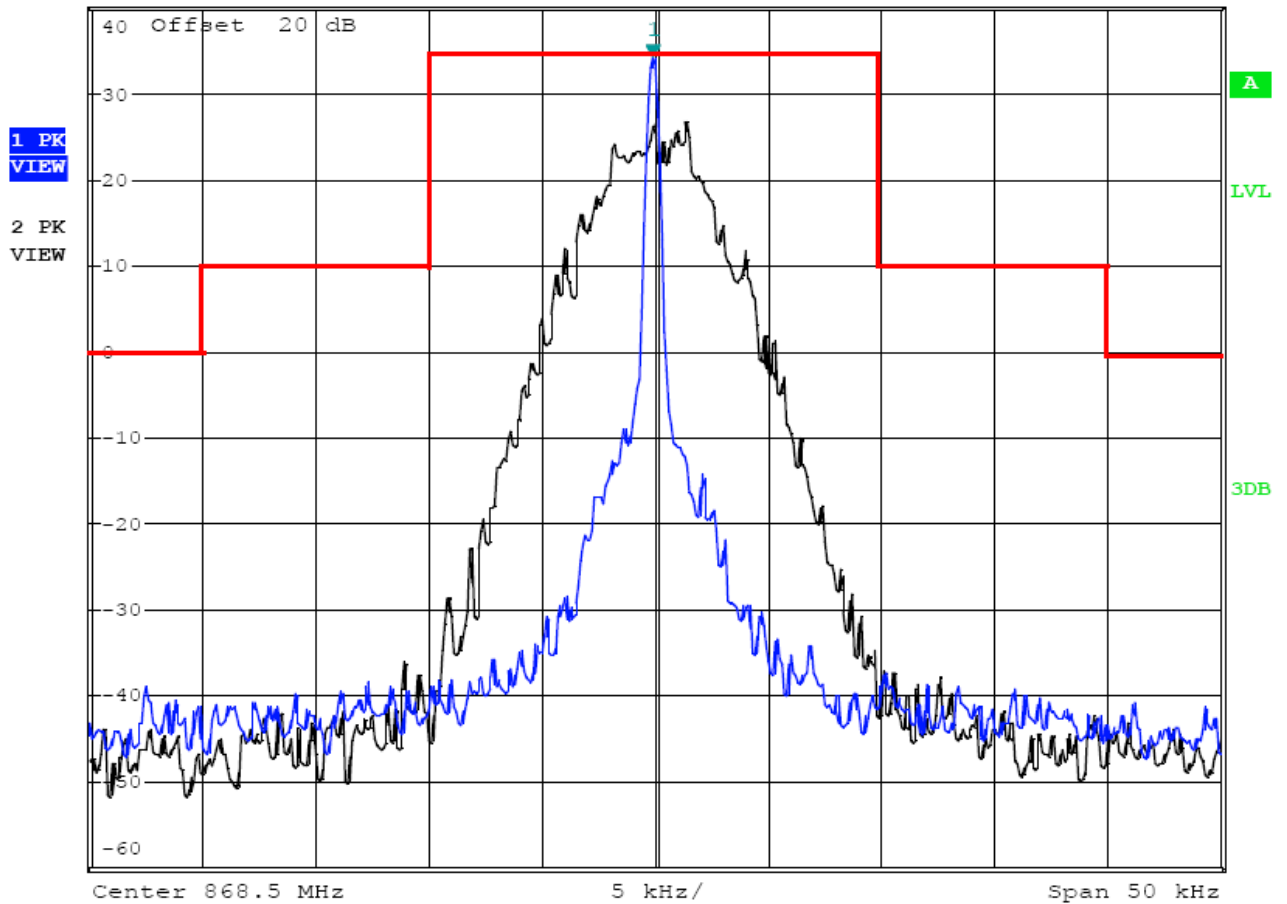

Date: 1.APR.2013 17:06:22

12.5 kHz Channel Spacing, 868.5000 MHz, 4FSK Modulation Only

Modulation Type	Channel Separation	Freq.(MHz)	FCC Applicable Mask	RBW	Audio Freq. (KHz)	Results
4FSK	12.5 KHz	900.5000	I	300Hz	/	Compliance

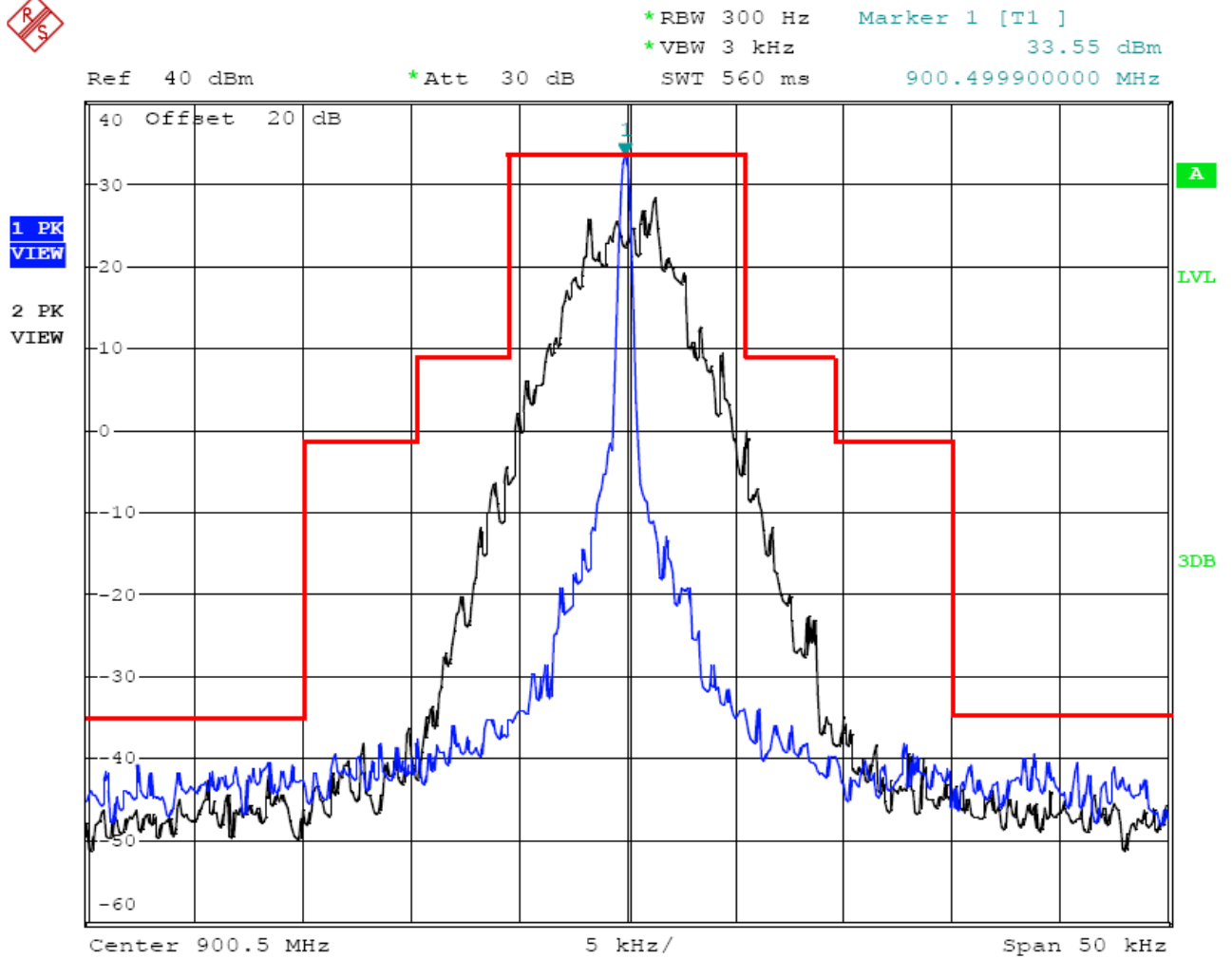

Date: 1.APR.2013 16:56:38

12.5 kHz Channel Spacing, 900.5000 MHz, 4FSK Modulation Only

Modulation Type	Channel Separation	Freq.(MHz)	FCC Applicable Mask	RBW	Audio Freq. (KHz)	Results
4FSK	12.5 KHz	935.5000	I	300Hz	/	Compliance

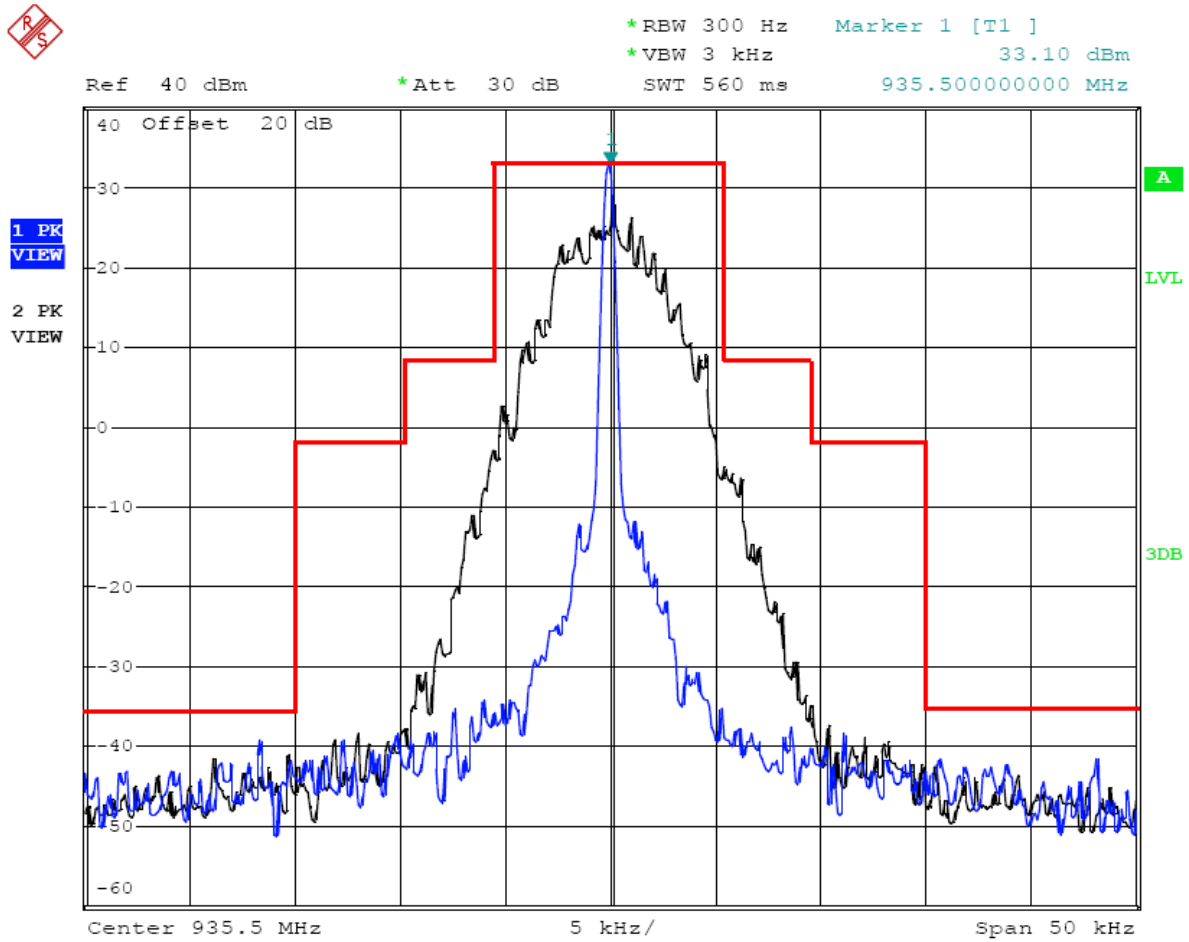

Date: 1.APR.2013 17:09:39

12.5 kHz Channel Spacing, 935.5000 MHz, 4FSK Modulation Only

Modulation Type	Channel Separation	Freq.(MHz)	FCC Applicable Mask	RBW	Audio Freq. (KHz)	Results
4FSK	12.5 KHz	939.5000	I	300Hz	/	Compliance

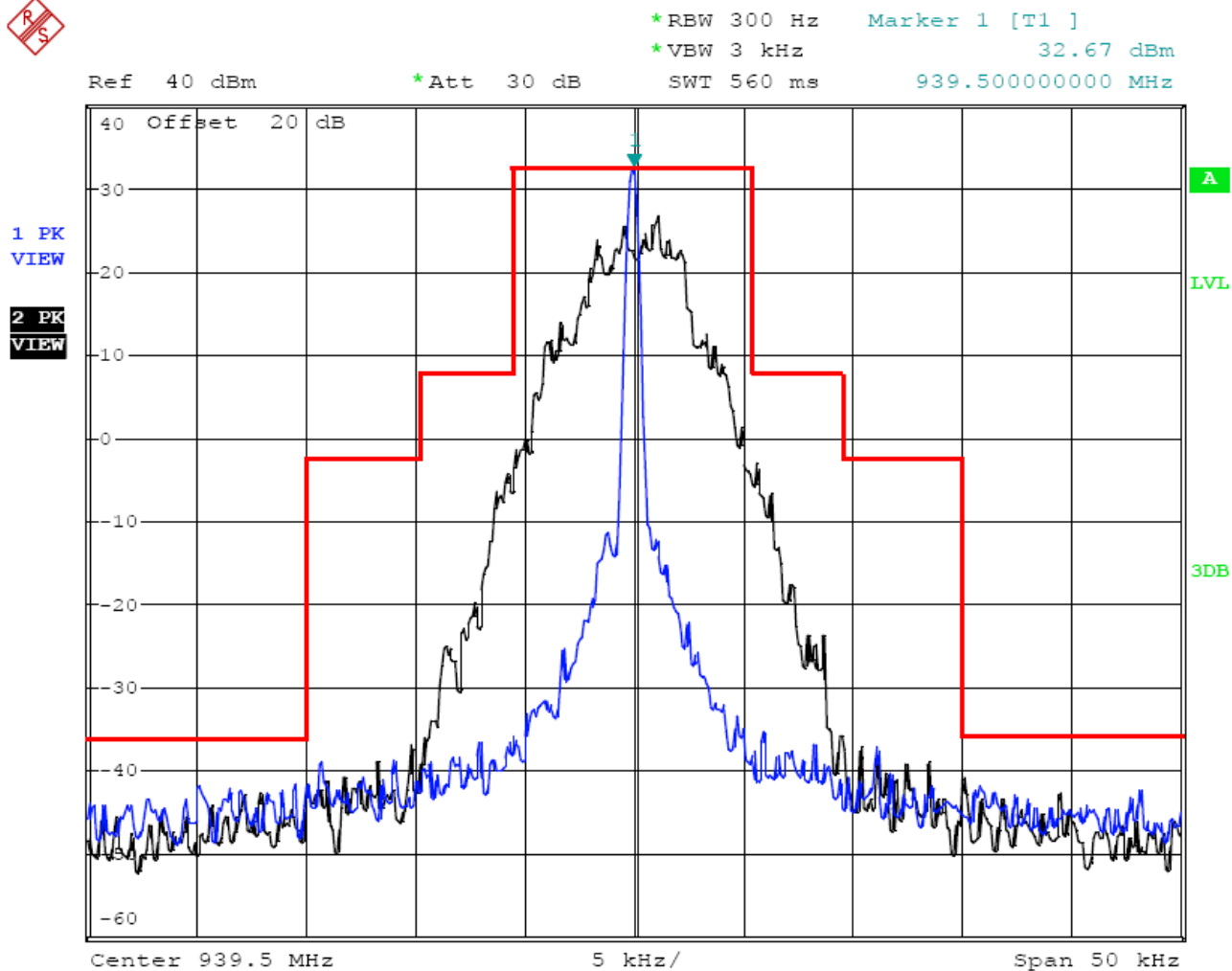

Date: 1.APR.2013 17:12:20

12.5 kHz Channel Spacing, 939.5000 MHz, 4FSK Modulation Only

Only For IC Review Not For FCC Review

Modulation Type	Channel Separation	Freq.(MHz)	IC Applicable Mask	RBW	Audio Freq. (KHz)	Results
FM	12.5 KHz	806.5000	D	100Hz	2.5	Complicance

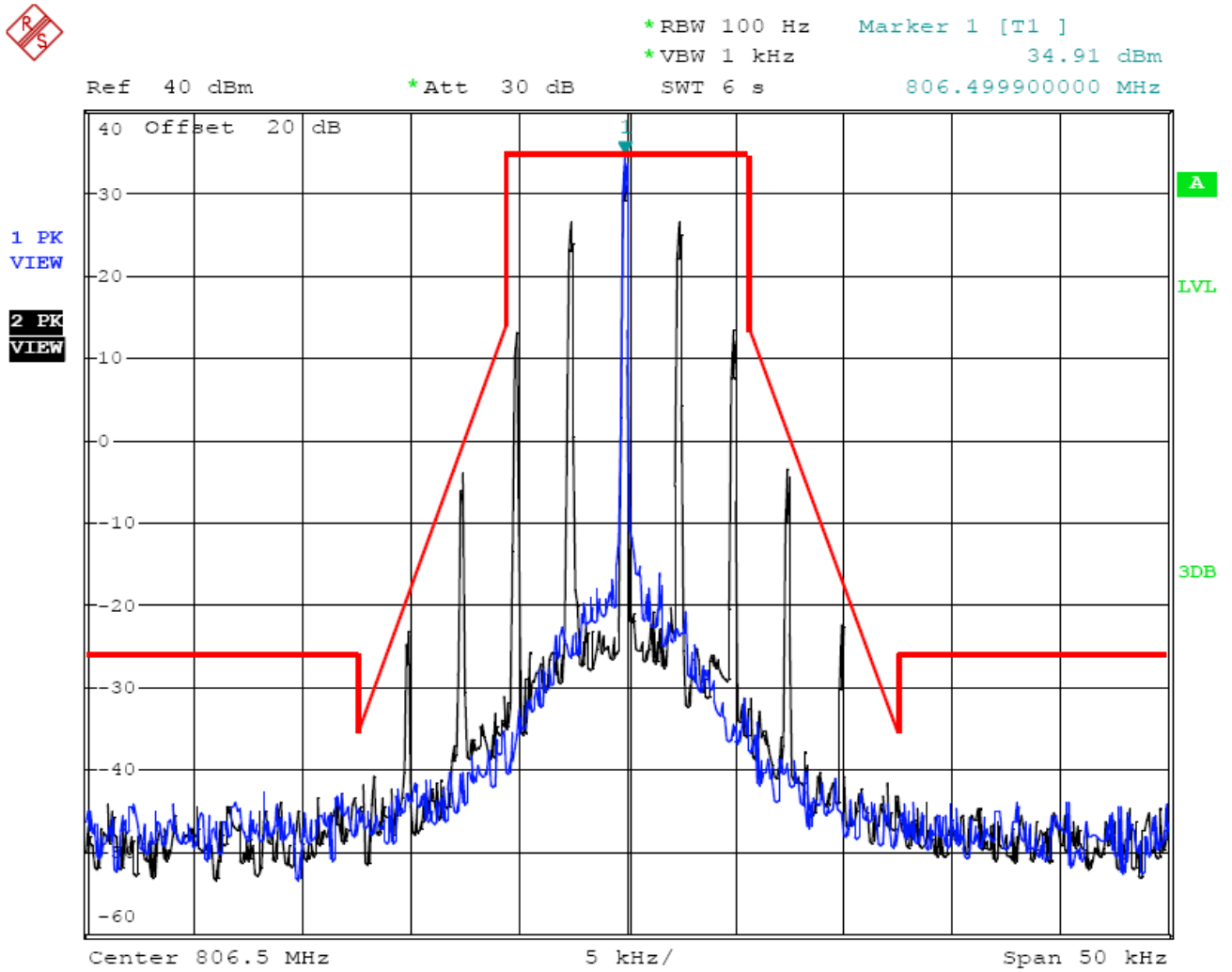

Date: 1.APR.2013 17:48:29

12.5 kHz Channel Spacing, 806.5000 MHz, 2500 Hz Audio Modulation Only

Modulation Type	Channel Separation	Freq.(MHz)	IC Applicable Mask	RBW	Audio Freq. (KHz)	Results
FM	12.5 KHz	817.0000	D	100Hz	2.5	Compliance

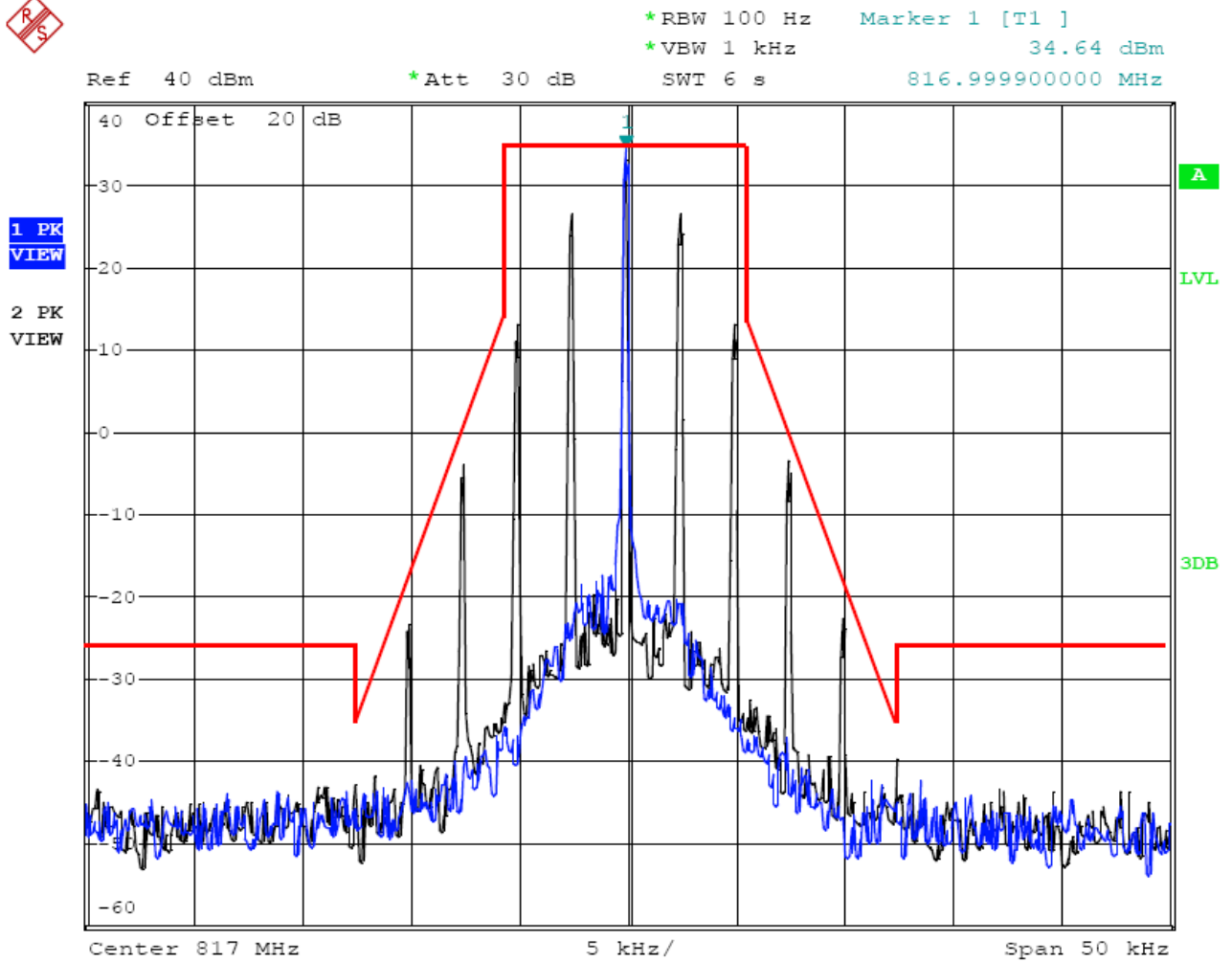

Date: 1.APR.2013 17:47:10

12.5 kHz Channel Spacing, 817.0000 MHz, 2500 Hz Audio Modulation Only

Modulation Type	Channel Separation	Freq.(MHz)	IC Applicable Mask	RBW	Audio Freq. (KHz)	Results
FM	12.5 KHz	823.5000	D	100Hz	2.5	Compliance



Ref 40 dBm *Att 30 dB SWT 6 s *RBW 100 Hz Marker 1 [T1] 34.59 dBm
*VBW 1 kHz 823.499900000 MHz

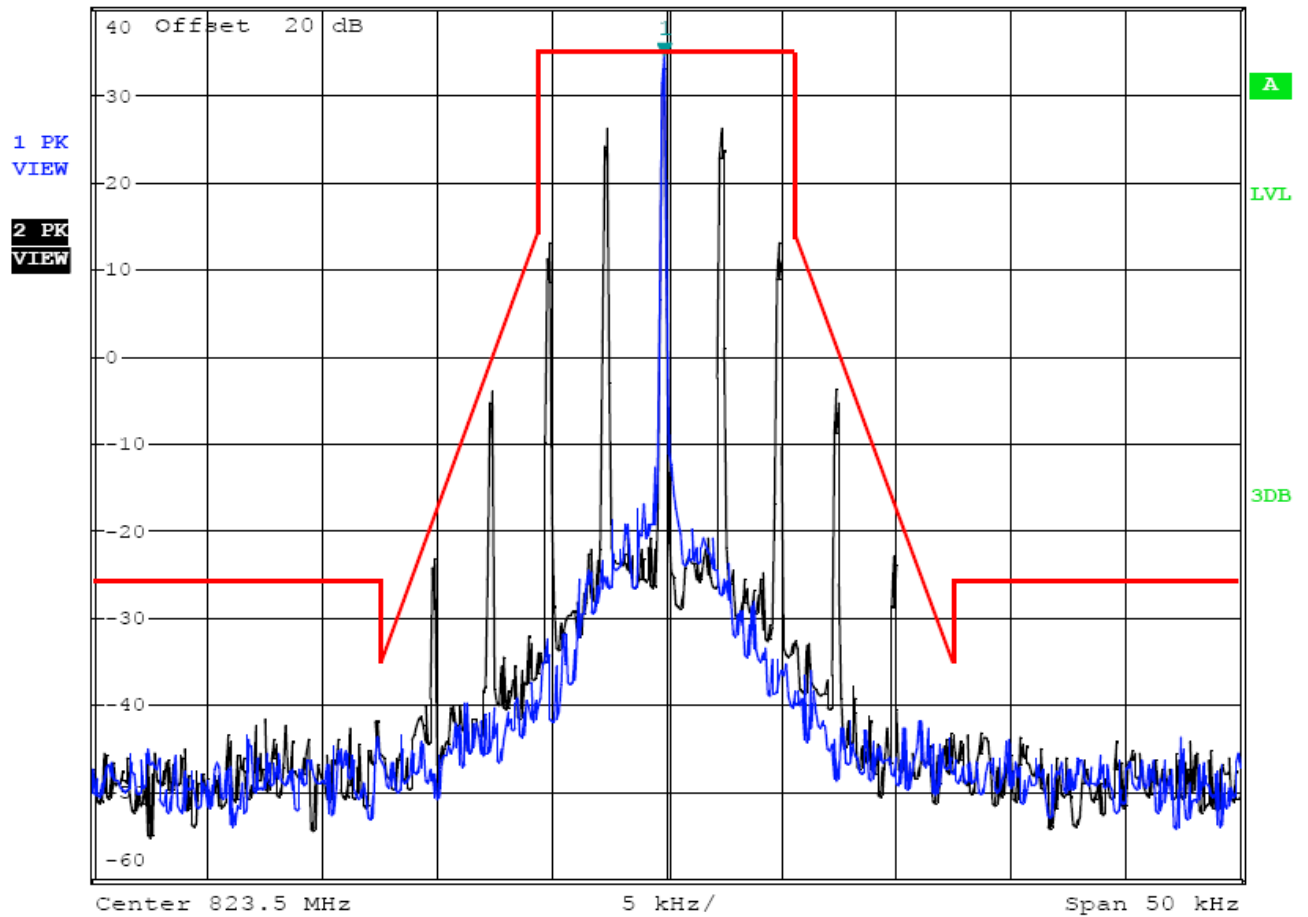

Date: 1.APR.2013 17:45:45

12.5 kHz Channel Spacing, 823.5000 MHz, 2500 Hz Audio Modulation Only

Modulation Type	Channel Separation	Freq.(MHz)	IC Applicable Mask	RBW	Audio Freq. (KHz)	Results
FM	12.5 KHz	860.0000	D	100Hz	2.5	Compliance

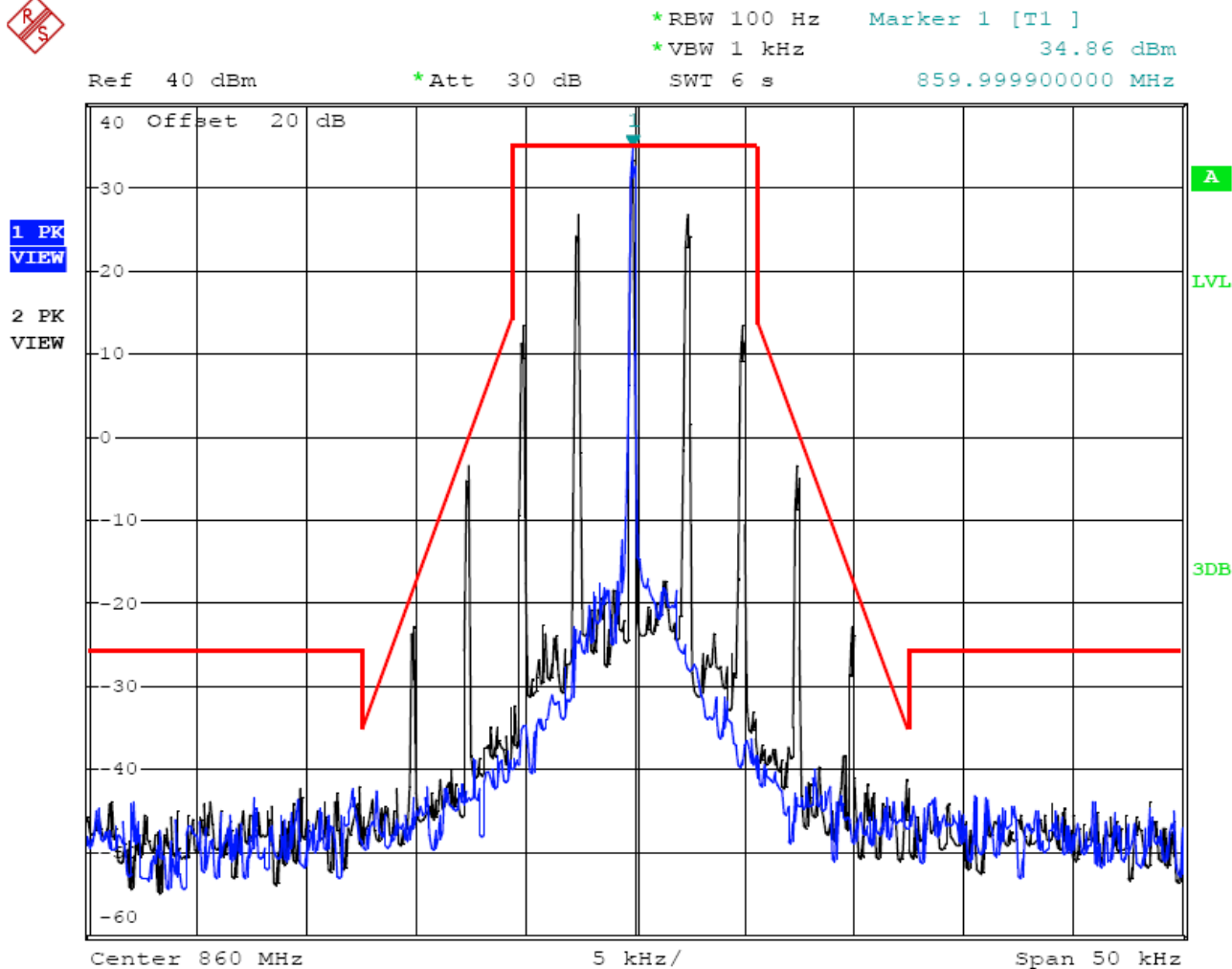

Date: 1.APR.2013 17:24:23

12.5 kHz Channel Spacing, 860.0000 MHz, 2500 Hz Audio Modulation Only

Modulation Type	Channel Separation	Freq.(MHz)	IC Applicable Mask	RBW	Audio Freq. (KHz)	Results
FM	12.5 KHz	868.5000	D	100Hz	2.5	Compliance



Ref 40 dBm *Att 30 dB *RBW 100 Hz Marker 1 [T1] 34.93 dBm
*VBW 1 kHz 868.499900000 MHz
SWT 6 s

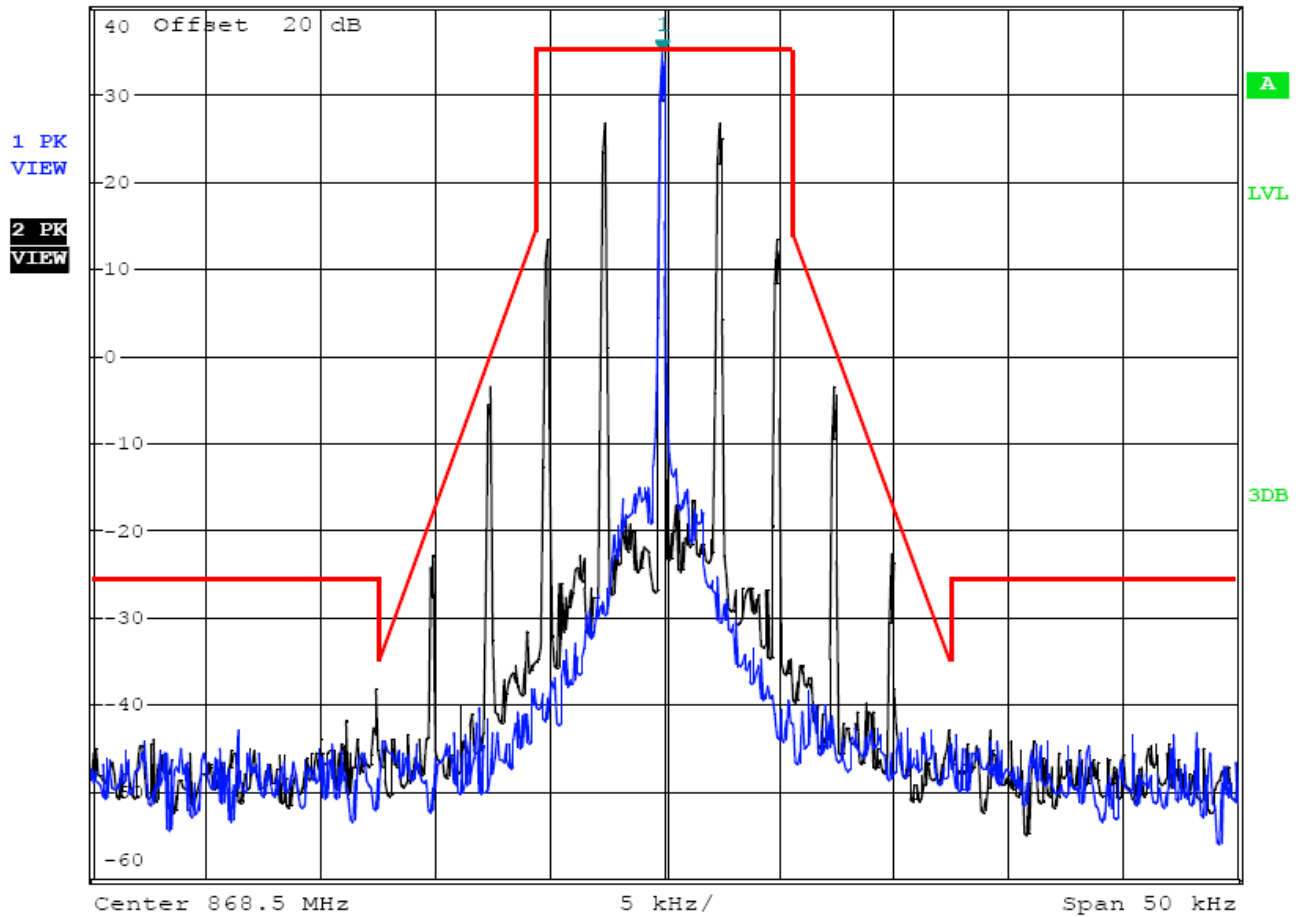

Date: 1.APR.2013 17:23:19

12.5 kHz Channel Spacing, 868.5000 MHz, 2500 Hz Audio Modulation Only

Modulation Type	Channel Separation	Freq.(MHz)	IC Applicable Mask	RBW	Audio Freq. (KHz)	Results
4FSK	12.5 KHz	851.5000	D	100Hz	/	Compliance

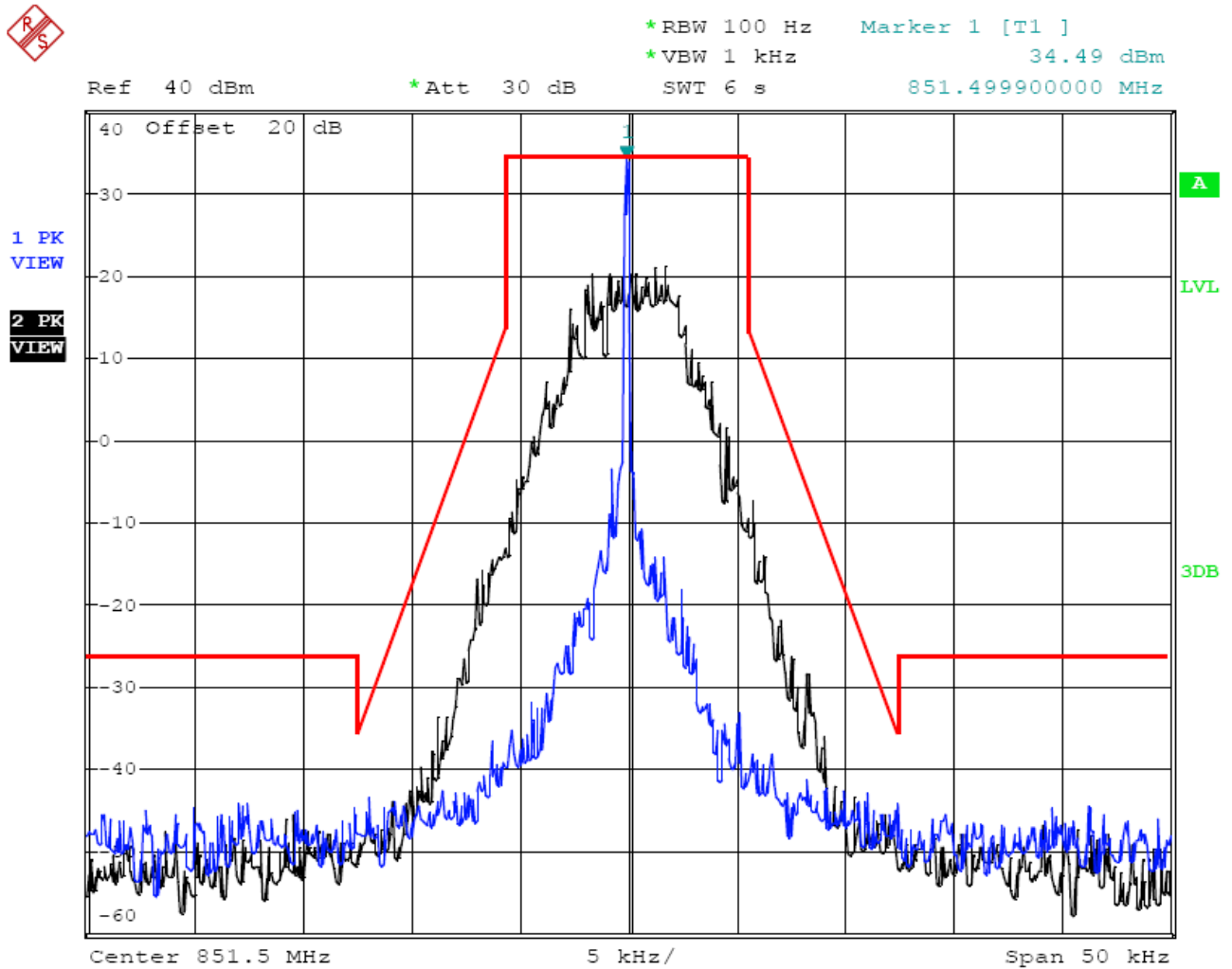

Date: 1.APR.2013 17:01:32

12.5 kHz Channel Spacing, 851.5000 MHz, 4FSK Modulation Only

Modulation Type	Channel Separation	Freq.(MHz)	IC Applicable Mask	RBW	Audio Freq. (KHz)	Results
4FSK	12.5 KHz	860.0000	D	100Hz	/	Compliance



*RBW 100 Hz Marker 1 [T1]
*VBW 1 kHz 34.45 dBm
Ref 40 dBm *Att 30 dB SWT 6 s 859.999900000 MHz

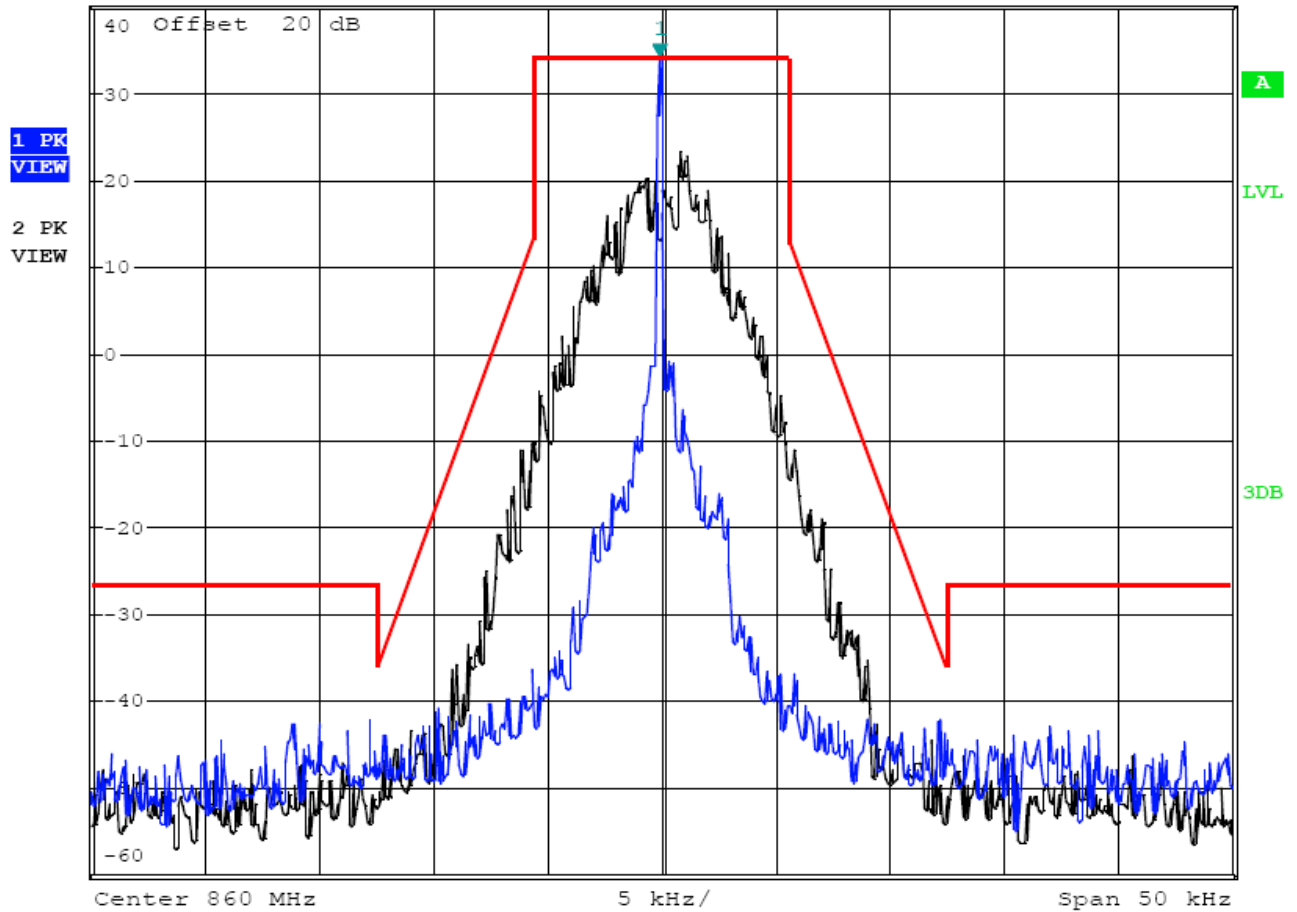

Date: 1.APR.2013 17:04:04

12.5 kHz Channel Spacing, 860.0000 MHz, 4FSK Modulation Only

Modulation Type	Channel Separation	Freq.(MHz)	IC Applicable Mask	RBW	Audio Freq. (KHz)	Results
4FSK	12.5 KHz	868.5000	D	100Hz	/	Compliance



*RBW 100 Hz Marker 1 [T1]
*VBW 1 kHz 34.20 dBm
Ref 40 dBm *Att 30 dB SWT 6 s 868.499900000 MHz

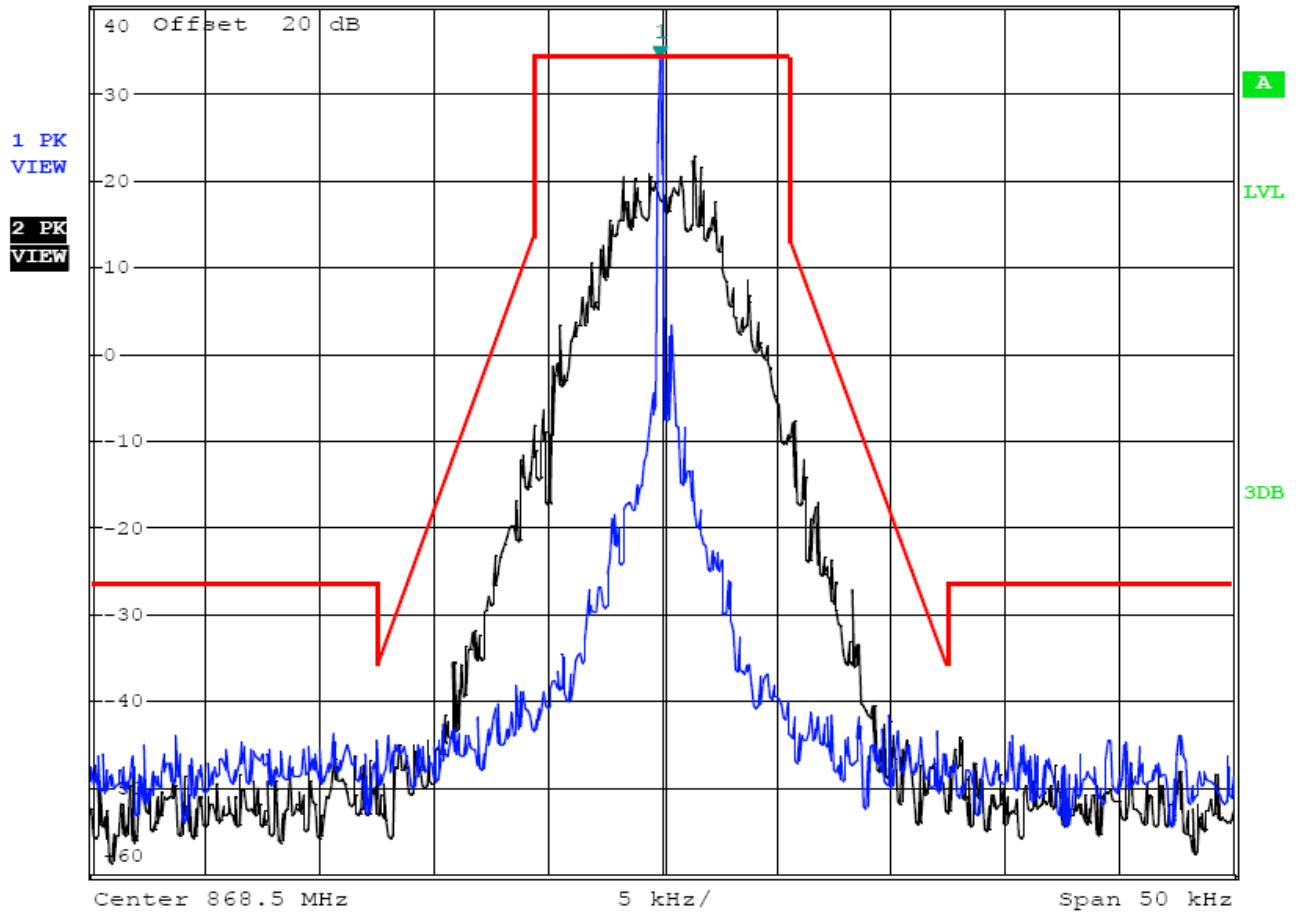

Date: 1.APR.2013 17:08:05

12.5 kHz Channel Spacing, 868.5000 MHz, 4FSK Modulation Only

4.3. Transmitter Radiated Spurious Emission

TEST APPLICABLE

According to the TIA/EIA 603 test method, and according to Section 90.210, the power of each unwanted emission shall be less than Transmitted Power as specified below for transmitters designed to operate with 12.5 KHz channel bandwidth:

- 1 On any frequency removed from the center of the authorized bandwidth f_0 to 5.625 KHz removed from f_0 : Zero dB
 - 2 On any frequency removed from the center of the authorized bandwidth by a displacement frequency (f_d in KHz) f_0 of more than 5.625 KHz but no more than 12.5 KHz: At least 7.27dB
 - 3 On any frequency removed from the center of the authorized bandwidth by a displacement frequency (f_d in KHz) f_0 of more than 12.5 KHz: At least $50 + 10 \log(P)$ dB or 70 dB, which ever is lesser attenuation.
- For transmitters designed to transmit with 25 KHz channel separation and equipped with an audio low-pass filter, the power of any emission must be attenuated below the unmodulated carrier power (P) as following:

- 1 On any frequency removed from the assigned frequency by more than 50 percent, but no more than 100 percent of the authorized bandwidth: At least 25 dB.
- 2 On any frequency removed from the assigned frequency by more than 100 percent, but no more than 250 percent of the authorized bandwidth: At least 35 dB.
- 3 On any frequency removed from the assigned frequency by more than 250 percent of the authorized bandwidth: At least $43 + 10 \log(P)$ dB.

TEST CONFIGURATION

Below 1GHz

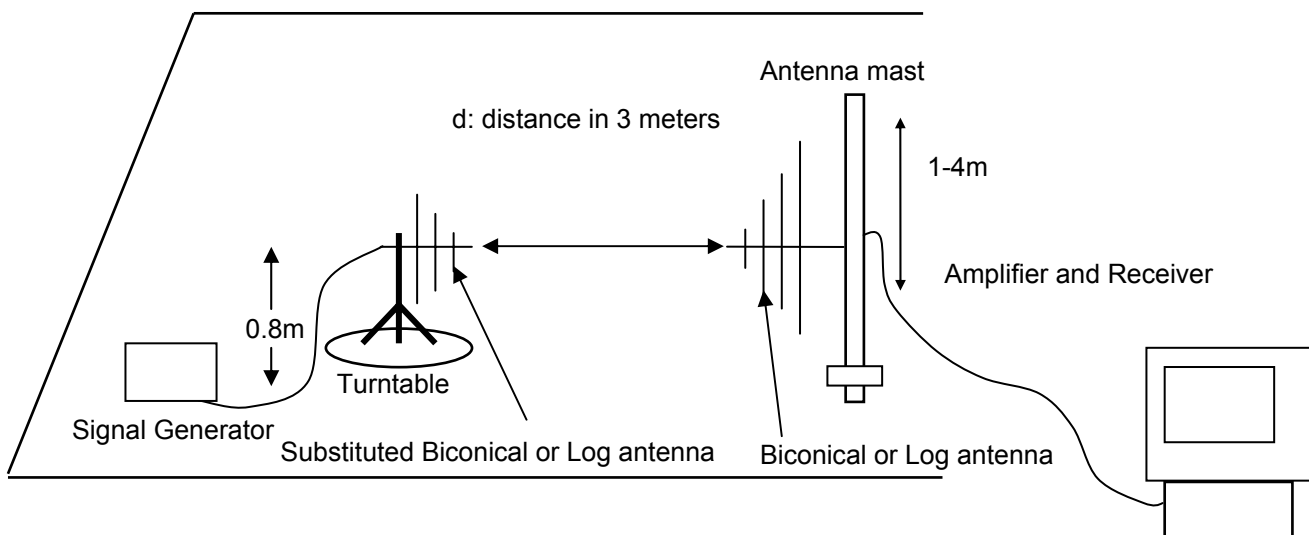
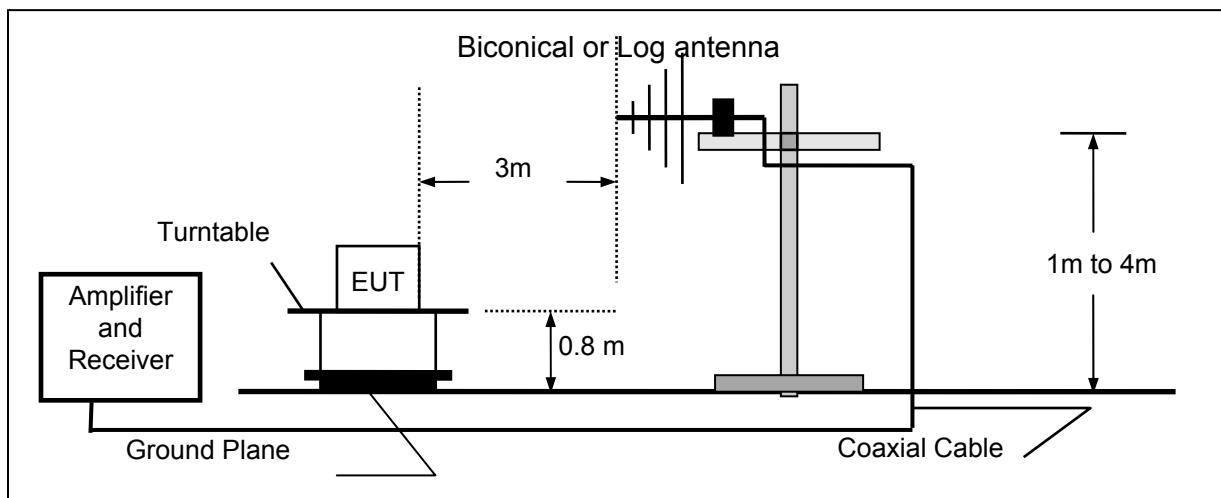

Above 1GHz

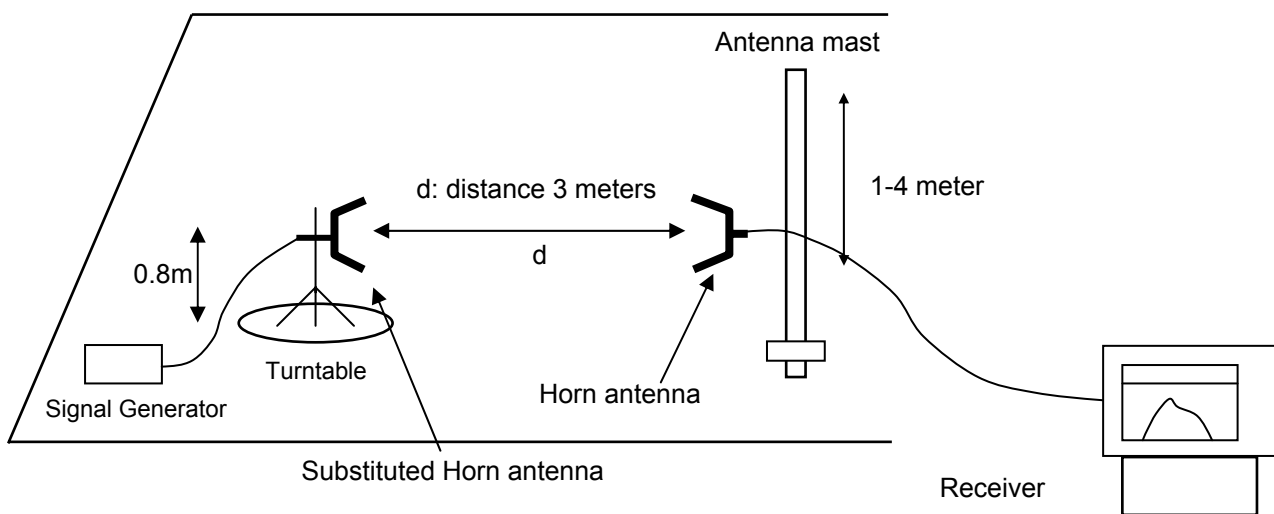
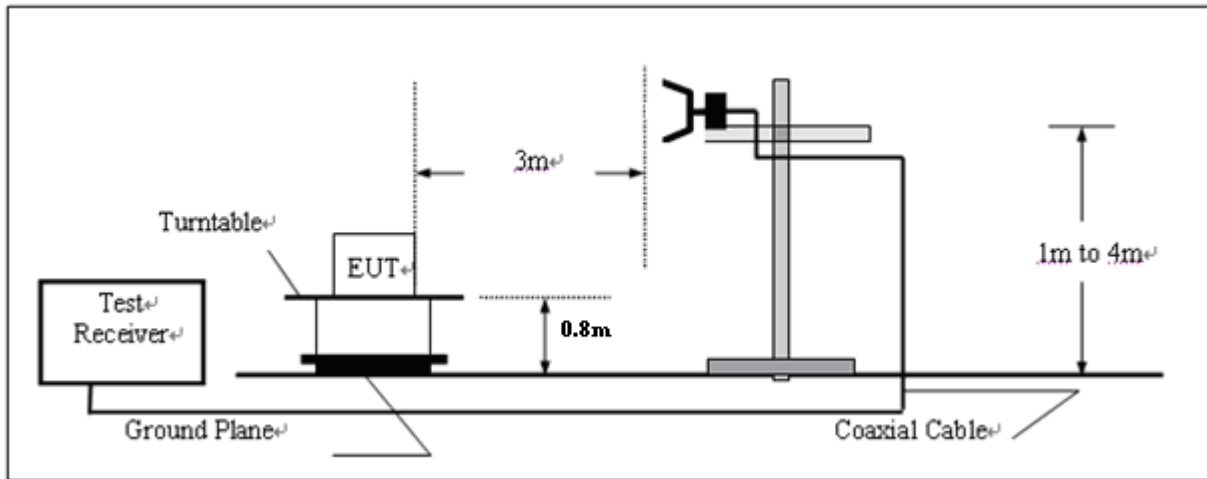
**TEST PROCEDURE**

- 1 Set the EMI Receiver (for measuring E-Field) and Receiver (for measuring EIRP) as follows:
Center Frequency: equal to the signal source
Resolution BW: 100 KHz
Video BW: VBW > RBW
Detector Mode: positive
Average: off
Span: 3 x the signal bandwidth
- 2 Load an appropriate correction factors file in EMI Receiver for correcting the field strength reading level
Total Correction Factor recorded in the EMI Receiver = Cable Loss + Antenna Factor + Amplifier Gain
 $E \text{ (dBuV/m)} = \text{Reading (dBuV)} + \text{Total Correction Factor (dB)}$
- 3 The transmitter under test was placed at the specified height on a non-conducting turntable (80 cm height)
- 4 Substitute the EUT by a signal generator and one of the following transmitting antenna (substitution antenna):
DIPOLE antenna for frequency from 30-1000 MHz or
HORN antenna for frequency above 1 GHz}.
- 5 Mount the transmitting antenna at 1.0 meter high from the ground plane.
- 6 Use one of the following antenna as a receiving antenna:
DIPOLE antenna for frequency from 30-1000 MHz or
HORN antenna for frequency above 1 GHz}.
- 7 If the DIPOLE antenna is used, tune its elements to the frequency as specified in the calibration manual.
- 8 Adjust both transmitting and receiving antenna in a VERTICAL polarization.
- 9 Tune the EMI Receivers to the test frequency.
- 10 Lower or raise the test antenna from 1 to 4 meters until the maximum signal level was detected.
- 11 The transmitter was rotated through 360° about a vertical axis until a higher maximum signal was received.
- 12 Lower or raise the test antenna from 1 to 4 meters until the maximum signal level was detected.

- 13 Adjust input signal to the substitution antenna until an equal or a known related level to that detected from the transmitter was obtained in the test receiver.
- 14 Record the power level read from the Average Power Meter and calculate the ERP/EIRP as follows:

$$P = P_1 - L_1 = (P_2 + L_2) - L_1 = P_3 + A + L_2 - L_1$$

$$\text{EIRP} = P + G_1 = P_3 + L_2 - L_1 + A + G_1$$

$$\text{ERP} = \text{EIRP} - 2.15 \text{ dB}$$

$$\text{Total Correction factor in EMI Receiver} = L_2 - L_1 + G_1$$
- Where:
P: Actual RF Power fed into the substitution antenna port after corrected.
P₁: Power output from the signal generator
P₂: Power measured at attenuator A input
P₃: Power reading on the Average Power Meter
EIRP: EIRP after correction
ERP: ERP after correction
- 15 Adjust both transmitting and receiving antenna in a Horizontal polarization, then repeat step (11) to (14).
16 Repeat step (4) to (16) for different test frequency
17 Repeat steps (3) to (12) with the substitution antenna oriented in horizontal polarization.
18 Actual gain of the EUT's antenna is the difference of the measured EIRP and measured RF power at the RF port. Correct the antenna gain if necessary.

TEST RESULTS

The Transmitter Radiated Spurious Emssion was performed to the Rated high power (3Watt) and Rated low power (10Watt) the datum that reported below is the worst case (Rated high power) of the two rated power conditions.

Modulation Type: FM

FCC Part 22.359, 74.462, 80.211 and 90.210 and RSS Gen, RSS 119 Issue 11 (25 kHz bandwidth only):

On any frequency removed from the center of the assigned channel by more than 250 percent at least:

High: $43 + 10 \log (\text{Pwatts}) = 43 + 10 \log (3.288) = 48.17 \text{ dB}$

Low: $43 + 10 \log (\text{Pwatts}) = 43 + 10 \log (3.012) = 47.79 \text{ dB}$

Calculation: Limit (dBm) = EL-43-10log10 (TP)

Notes: EL is the emission level of the Output Power expressed in dBm,

In this application, the EL is 35.17 dBm.

Limit (dBm) = 35.17-43-10log10 (3.288) = -13 dBm

FCC Part 22.359, 74.462, 80.211 and 90.210 and RSS Gen, RSS 119 Issue 11 (12.5 kHz bandwidth only): On any frequency removed from the center of the authorized bandwidth by a displacement frequency (f d in kHz) of more than 12.5 kHz at least:

High: $50 + 10 \log (\text{Pwatts}) = 50 + 10 \log (3.319) = 55.21 \text{ dB}$

Low: $50 + 10 \log (\text{Pwatts}) = 50 + 10 \log (3.069) = 54.87 \text{ dB}$

Note: In general, the worse case attenuation requirement shown above was applied.

Calculation: Limit (dBm) = EL-50-10log10 (TP)

Notes: EL is the emission level of the Output Power expressed in dBm,

In this application, the EL is 35.21 dBm.

Limit (dBm) = 35.21-50-10log10 (3.319) = -20 dBm

Modulation Type: 4FSK

FCC Part 22.359, 74.462, 80.211 and 90.210 and RSS Gen, RSS 119 Issue 11 (12.5 kHz Bandwidth only):

On any frequency removed from the center of the authorized bandwidth by a displacement frequency (f d in kHz) of more than 12.5 kHz at least:

High: $50 + 10 \log (\text{Pwatts}) = 50 + 10 \log (3.334) = 55.23 \text{ dB}$

Low: $50 + 10 \log (\text{Pwatts}) = 50 + 10 \log (3.090) = 54.90 \text{ dB}$

Note: In general, the worse case attenuation requirement shown above was applied.

Calculation: Limit (dBm) = EL-50-10log10 (TP)

Notes: EL is the emission level of the Output Power expressed in dBm,

In this application, the EL is 25.23 dBm.

Limit (dBm) = 25.23-50-10log10 (3.334) = -20 dBm

Note: 1. In general, the worse case attenuation requirement shown above was applied.

2. The measurement frequency range from 30 MHz to 10 GHz.

3. *** means that the emission level is too low to be measured or at least 20 dB down than the limit.

Modulation		FM		Channel Separation		25KHz		
Test Channel		Low Channel		Test Frequency		806.5000 MHz		
Frequency (MHz)	E-Field Level (dBuv/m)	EMI Detector (Peak/QP)	Antenna Polarization	Antenna Height (cm)	Table Angle (Degree)	ERP measured by Substitution Method (dBm)	Limit (dBm)	Margin (dB)
1613.000	71.06	Peak	H	100	220	-34.44	-13	21.44
2419.500	61.38	Peak	H	140	10	-40.25	-13	27.25
4032.5000	62.80	Peak	H	120	200	-39.45	-13	26.45
...	...		H					
1613.000	72.96	Peak	V	100	32	-32.54	-13	19.54
2419.500	65.40	Peak	V	100	41	-36.23	-13	23.23
4032.5000	63.80	Peak	V	120	350	-38.45	-13	25.45
...	...		V			...		

Modulation		FM		Channel Separation		25KHz		
Test Channel		Middle Channel		Test Frequency		817.0000 MHz		
Frequency (MHz)	E-Field Level (dBuv/m)	EMI Detector (Peak/QP)	Antenna Polarization	Antenna Height (cm)	Table Angle (Degree)	ERP measured by Substitution Method (dBm)	Limit (dBm)	Margin (dB)
1634.000	75.00	Peak	H	130	45	-30.50	-13	17.50
2451.000	64.01	Peak	H	120	111	-37.62	-13	24.62
3268.000	62.83	Peak	H	100	354	-39.42	-13	26.42
...	...		H					
1634.000	74.40	Peak	V	110	65	-31.10	-13	18.10
2451.000	66.05	Peak	V	100	33	-35.58	-13	22.58
3268.000	64.64	Peak	V	100	100	-37.61	-13	24.61
...	...		V			...		

Modulation		FM		Channel Separation		25KHz		
Test Channel		High Channel		Test Frequency		823.5000 MHz		
Frequency (MHz)	E-Field Level (dBuv/m)	EMI Detector (Peak/QP)	Antenna Polarization	Antenna Height (cm)	Table Angle (Degree)	ERP measured by Substitution Method (dBm)	Limit (dBm)	Margin (dB)
1647.000	71.19	Peak	H	120	135	-34.31	-13	21.31
3294.000	65.07	Peak	H	140	12	-36.56	-13	23.56
4117.500	66.86	Peak	H	150	210	-35.39	-13	22.39
...			H					
1647.000	75.19	Peak	V	120	35	-30.31	-13	17.31
3294.000	67.94	Peak	V	100	354	-33.69	-13	20.69
4117.500	65.86	Peak	V	150	344	-36.39	-13	23.39
...	...		V			...		

Modulation		FM		Channel Separation		25KHz		
Test Channel		Low Channel		Test Frequency		851.5000 MHz		
Frequency (MHz)	E-Field Level (dBuv/m)	EMI Detector (Peak/QP)	Antenna Polarization	Antenna Height (cm)	Table Angle (Degree)	ERP measured by Substitution Method (dBm)	Limit (dBm)	Margin (dB)
1703.000	71.19	Peak	H	100	274	-34.31	-13	21.31
2554.500	65.98	Peak	H	100	32	-35.65	-13	22.65
4257.500	64.77	Peak	H	100	45	-37.48	-13	24.48
...	...		H					
1703.000	71.23	Peak	V	100	115	-34.27	-13	21.27
2554.500	63.07	Peak	V	100	185	-38.56	-13	25.56
4257.500	66.76	Peak	V	100	220	-35.49	-13	22.49
...	...		V			...		

Modulation		FM		Channel Separation		25KHz		
Test Channel		Middle Channel		Test Frequency		860.0000 MHz		
Frequency (MHz)	E-Field Level (dBuv/m)	EMI Detector (Peak/QP)	Antenna Polarization	Antenna Height (cm)	Table Angle (Degree)	ERP measured by Substitution Method (dBm)	Limit (dBm)	Margin (dB)
1720.000	72.07	Peak	H	150	352	-33.43	-13	20.43
2580.000	64.98	Peak	H	140	223	-36.65	-13	23.65
4300.000	63.86	Peak	H	100	142	-38.39	-13	25.39
...	...		H					
1720.000	73.19	Peak	V	130	158	-32.31	-13	19.31
2580.000	67.74	Peak	V	100	341	-33.89	-13	20.89
4300.000	65.77	Peak	V	120	127	-36.48	-13	23.48
...	...		V			...		

Modulation		FM		Channel Separation		25KHz		
Test Channel		High Channel		Test Frequency		868.5000 MHz		
Frequency (MHz)	E-Field Level (dBuv/m)	EMI Detector (Peak/QP)	Antenna Polarization	Antenna Height (cm)	Table Angle (Degree)	ERP measured by Substitution Method (dBm)	Limit (dBm)	Margin (dB)
1737.000	71.19	Peak	H	140	48	-34.31	-13	21.31
2605.500	70.07	Peak	H	110	115	-31.56	-13	18.56
4342.500	63.72	Peak	H	100	258	-38.53	-13	25.53
...			H					
1737.000	70.94	Peak	V	150	320	-34.56	-13	21.56
2605.500	65.08	Peak	V	100	285	-36.55	-13	23.55
4342.500	60.89	Peak	V	150	111	-41.36	-13	28.36
...	...		V			...		

Modulation		FM		Channel Separation		12.5KHz		
Test Channel		Low Channel		Test Frequency		806.5000 MHz		
Frequency (MHz)	E-Field Level (dBuv/m)	EMI Detector (Peak/QP)	Antenna Polarization	Antenna Height (cm)	Table Angle (Degree)	ERP measured by Substitution Method (dBm)	Limit (dBm)	Margin (dB)
1613.000	68.19	Peak	H	110	21	-37.31	-20	17.31
2419.500	66.10	Peak	H	100	105	-35.53	-20	15.53
4032.5000	63.86	Peak	H	150	75	-38.39	-20	18.39
...	...		H					
1613.000	68.37	Peak	V	100	125	-37.13	-20	17.13
2419.500	63.88	Peak	V	150	215	-37.75	-20	17.75
4032.5000	62.53	Peak	V	100	302	-39.72	-20	19.72
...	...		V			...		

Modulation		FM		Channel Separation		12.5KHz		
Test Channel		Middle Channel		Test Frequency		817.0000 MHz		
Frequency (MHz)	E-Field Level (dBuv/m)	EMI Detector (Peak/QP)	Antenna Polarization	Antenna Height (cm)	Table Angle (Degree)	ERP measured by Substitution Method (dBm)	Limit (dBm)	Margin (dB)
1634.000	67.06	Peak	H	130	157	-38.44	-20	18.44
2451.000	63.07	Peak	H	100	354	-38.56	-20	18.56
3268.000	58.36	Peak	H	120	15	-43.89	-20	23.89
...	...		H					
1634.000	65.93	Peak	V	100	229	-39.57	-20	19.57
2451.000	59.10	Peak	V	100	25	-42.53	-20	22.53
3268.000	60.49	Peak	V	150	66	-41.76	-20	21.76
...	...		V			...		

Modulation		FM		Channel Separation		12.5KHz		
Test Channel		High Channel		Test Frequency		823.5000 MHz		
Frequency (MHz)	E-Field Level (dBuv/m)	EMI Detector (Peak/QP)	Antenna Polarization	Antenna Height (cm)	Table Angle (Degree)	ERP measured by Substitution Method (dBm)	Limit (dBm)	Margin (dB)
1647.000	66.19	Peak	H	100	215	-39.31	-20	19.31
3294.000	64.30	Peak	H	150	345	-37.33	-20	17.33
4117.500	58.54	Peak	H	150	85	-43.71	-20	23.71
...			H					
1647.000	65.73	Peak	V	100	45	-39.77	-20	19.77
3294.000	59.11	Peak	V	130	67	-42.52	-20	22.52
4117.500	60.03	Peak	V	150	252	-42.22	-20	22.22
...	...		V			...		

Modulation		FM		Channel Separation		12.5KHz		
Test Channel		Low Channel		Test Frequency		851.5000 MHz		
Frequency (MHz)	E-Field Level (dBuv/m)	EMI Detector (Peak/QP)	Antenna Polarization	Antenna Height (cm)	Table Angle (Degree)	ERP measured by Substitution Method (dBm)	Limit (dBm)	Margin (dB)
1703.000	66.02	Peak	H	150	252	-39.48	-20	19.48
2554.500	64.12	Peak	H	150	214	-37.51	-20	17.51
4257.500	58.86	Peak	H	110	105	-43.39	-20	23.39
...	...		H					
1703.000	66.86	Peak	V	100	77	-38.64	-20	18.64
2554.500	63.95	Peak	V	120	21	-37.68	-20	17.68
4257.500	63.54	Peak	V	120	144	-38.71	-20	18.71
...	...		V			...		

Modulation		FM		Channel Separation		12.5KHz		
Test Channel		Middle Channel		Test Frequency		860.0000 MHz		
Frequency (MHz)	E-Field Level (dBuv/m)	EMI Detector (Peak/QP)	Antenna Polarization	Antenna Height (cm)	Table Angle (Degree)	ERP measured by Substitution Method (dBm)	Limit (dBm)	Margin (dB)
1720.000	66.00	Peak	H	150	42	-39.50	-20	19.50
2580.000	64.08	Peak	H	150	157	-37.55	-20	17.55
4300.000	61.13	Peak	H	100	226	-41.12	-20	21.12
...	...		H					
1720.000	66.97	Peak	V	100	254	-38.53	-20	18.53
2580.000	64.00	Peak	V	130	33	-37.63	-20	17.63
4300.000	59.29	Peak	V	120	110	-42.96	-20	22.96
...	...		V			...		

Modulation		FM		Channel Separation		12.5KHz		
Test Channel		High Channel		Test Frequency		868.5000 MHz		
Frequency (MHz)	E-Field Level (dBuv/m)	EMI Detector (Peak/QP)	Antenna Polarization	Antenna Height (cm)	Table Angle (Degree)	ERP measured by Substitution Method (dBm)	Limit (dBm)	Margin (dB)
1737.000	66.87	Peak	H	130	41	-38.63	-20	18.63
2605.500	65.76	Peak	H	100	325	-35.87	-20	15.87
4342.500	60.34	Peak	H	120	12	-41.91	-20	21.91
...			H					
1737.000	66.28	Peak	V	100	22	-39.22	-20	19.22
2605.500	61.08	Peak	V	120	87	-40.55	-20	20.55
4342.500	63.57	Peak	V	100	210	-38.68	-20	18.68
...	...		V			...		

Modulation		FM		Channel Separation		12.5KHz		
Test Channel		Low Channel		Test Frequency		896.5000 MHz		
Frequency (MHz)	E-Field Level (dBuv/m)	EMI Detector (Peak/QP)	Antenna Polarization	Antenna Height (cm)	Table Angle (Degree)	ERP measured by Substitution Method (dBm)	Limit (dBm)	Margin (dB)
1793.000	65.87	Peak	H	100	125	-39.63	-20	19.63
2689.500	61.74	Peak	H	110	162	-39.89	-20	19.89
4482.500	63.73	Peak	H	120	245	-38.52	-20	18.52
...	...		H					
1793.000	67.34	Peak	V	110	55	-38.16	-20	18.16
2689.500	62.77	Peak	V	100	173	-38.86	-20	18.86
4482.500	63.53	Peak	V	150	15	-38.72	-20	18.72
...	...		V			...		

Modulation		FM		Channel Separation		12.5KHz		
Test Channel		High Channel		Test Frequency		900.5000 MHz		
Frequency (MHz)	E-Field Level (dBuv/m)	EMI Detector (Peak/QP)	Antenna Polarization	Antenna Height (cm)	Table Angle (Degree)	ERP measured by Substitution Method (dBm)	Limit (dBm)	Margin (dB)
1801.000	65.86	Peak	H	100	237	-39.64	-20	19.64
2701.500	63.08	Peak	H	150	74	-38.55	-20	18.55
3602.000	61.98	Peak	H	100	111	-40.27	-20	20.27
...	...		H					
1801.000	66.19	Peak	V	150	204	-39.31	-20	19.31
2701.500	65.89	Peak	V	110	47	-35.74	-20	15.74
3602.000	63.53	Peak	V	100	162	-38.72	-20	18.72
...	...		V			...		

Modulation		FM		Channel Separation		12.5KHz		
Test Channel		Low Channel		Test Frequency		935.5000 MHz		
Frequency (MHz)	E-Field Level (dBuv/m)	EMI Detector (Peak/QP)	Antenna Polarization	Antenna Height (cm)	Table Angle (Degree)	ERP measured by Substitution Method (dBm)	Limit (dBm)	Margin (dB)
1871.000	66.01	Peak	H	150	54	-39.49	-20	19.49
2806.500	62.19	Peak	H	130	274	-39.44	-20	19.44
4677.500	62.87	Peak	H	120	33	-39.38	-20	19.38
...	...		H					
1871.000	67.46	Peak	V	100	135	-38.04	-20	18.04
2806.500	61.11	Peak	V	120	35	-40.52	-20	20.52
4677.500	57.57	Peak	V	110	300	-44.68	-20	24.68
...	...		V			...		

Modulation		FM		Channel Separation		12.5KHz		
Test Channel		High Channel		Test Frequency		939.5000 MHz		
Frequency (MHz)	E-Field Level (dBuv/m)	EMI Detector (Peak/QP)	Antenna Polarization	Antenna Height (cm)	Table Angle (Degree)	ERP measured by Substitution Method (dBm)	Limit (dBm)	Margin (dB)
1879.000	62.23	Peak	H	100	124	-43.27	-20	23.27
2818.500	63.52	Peak	H	150	67	-38.11	-20	18.11
4697.000	58.90	Peak	H	150	22	-43.35	-20	23.35
...	...		H					
1879.000	63.90	Peak	V	120	158	-41.60	-20	21.60
2818.500	63.68	Peak	V	100	55	-37.95	-20	17.95
4697.000	62.57	Peak	V	120	278	-39.68	-20	19.68
...	...		V			...		

Modulation		4FSK		Channel Separation		12.5KHz		
Test Channel		Low Channel		Test Frequency		806.5000 MHz		
Frequency (MHz)	E-Field Level (dBuv/m)	EMI Detector (Peak/QP)	Antenna Polarization	Antenna Height (cm)	Table Angle (Degree)	ERP measured by Substitution Method (dBm)	Limit (dBm)	Margin (dB)
1613.000	65.23	Peak	H	120	370	-40.27	-20	20.27
2419.500	65.55	Peak	H	120	89	-36.08	-20	16.08
4032.5000	64.28	Peak	H	100	75	-37.97	-20	17.97
...	...		H					
1613.000	63.93	Peak	V	150	182	-41.57	-20	21.57
2419.500	64.55	Peak	V	150	45	-37.08	-20	17.08
4032.5000	64.52	Peak	V	120	111	-37.73	-20	17.73
...	...		V			...		

Modulation		4FSK		Channel Separation		12.5KHz		
Test Channel		Middle Channel		Test Frequency		817.0000 MHz		
Frequency (MHz)	E-Field Level (dBuv/m)	EMI Detector (Peak/QP)	Antenna Polarization	Antenna Height (cm)	Table Angle (Degree)	ERP measured by Substitution Method (dBm)	Limit (dBm)	Margin (dB)
1634.000	65.00	Peak	H	100	75	-40.50	-20	20.50
2451.000	63.76	Peak	H	150	84	-37.87	-20	17.87
3268.000	61.68	Peak	H	150	163	-40.57	-20	20.57
...	...		H					
1634.000	64.19	Peak	V	100	78	-41.31	-20	21.31
2451.000	62.84	Peak	V	100	66	-38.79	-20	18.79
3268.000	60.54	Peak	V	100	188	-41.71	-20	21.71
...	...		V			...		

Modulation		4FSK		Channel Separation		12.5KHz		
Test Channel		High Channel		Test Frequency		823.5000 MHz		
Frequency (MHz)	E-Field Level (dBuv/m)	EMI Detector (Peak/QP)	Antenna Polarization	Antenna Height (cm)	Table Angle (Degree)	ERP measured by Substitution Method (dBm)	Limit (dBm)	Margin (dB)
1647.000	65.90	Peak	H	150	258	-39.60	-20	19.60
3294.000	64.08	Peak	H	150	266	-37.55	-20	17.55
4117.500	62.34	Peak	H	150	45	-39.91	-20	19.91
...	...		H					
1647.000	65.90	Peak	V	100	312	-39.60	-20	19.60
3294.000	65.75	Peak	V	100	355	-35.88	-20	15.88
4117.500	63.65	Peak	V	120	173	-38.60	-20	18.60
...	...		V			...		

Modulation		4FSK		Channel Separation		12.5KHz		
Test Channel		Low Channel		Test Frequency		851.5000 MHz		
Frequency (MHz)	E-Field Level (dBuv/m)	EMI Detector (Peak/QP)	Antenna Polarization	Antenna Height (cm)	Table Angle (Degree)	ERP measured by Substitution Method (dBm)	Limit (dBm)	Margin (dB)
1703.000	66.10	Peak	H	150	152	-39.40	-20	19.40
2554.500	62.78	Peak	H	100	129	-38.85	-20	18.85
4257.500	60.54	Peak	H	100	127	-41.71	-20	21.71
...	...		H					
1703.000	66.23	Peak	V	120	38	-39.27	-20	19.27
2554.500	65.03	Peak	V	100	336	-36.60	-20	16.60
4257.500	62.58	Peak	V	100	143	-39.67	-20	19.67
...	...		V			...		

Modulation		4FSK		Channel Separation		12.5KHz		
Test Channel		Middle Channel		Test Frequency		860.0000 MHz		
Frequency (MHz)	E-Field Level (dBuv/m)	EMI Detector (Peak/QP)	Antenna Polarization	Antenna Height (cm)	Table Angle (Degree)	ERP measured by Substitution Method (dBm)	Limit (dBm)	Margin (dB)
1720.000	66.23	Peak	H	120	65	-39.27	-20	19.27
2580.000	64.85	Peak	H	120	37	-36.78	-20	16.78
4300.000	62.57	Peak	H	120	111	-39.68	-20	19.68
...	...		H					
1720.000	66.33	Peak	V	100	323	-39.17	-20	19.17
2580.000	63.80	Peak	V	100	58	-37.83	-20	17.83
4300.000	61.80	Peak	V	100	75	-40.45	-20	20.45
...	...		V			...		

Modulation		4FSK		Channel Separation		12.5KHz		
Test Channel		High Channel		Test Frequency		868.5000 MHz		
Frequency (MHz)	E-Field Level (dBuv/m)	EMI Detector (Peak/QP)	Antenna Polarization	Antenna Height (cm)	Table Angle (Degree)	ERP measured by Substitution Method (dBm)	Limit (dBm)	Margin (dB)
1737.000	66.86	Peak	H	100	335	-38.64	-20	18.64
2605.500	64.05	Peak	H	120	173	-37.58	-20	17.58
4342.500	61.63	Peak	H	150	125	-40.62	-20	20.62
			H					
1737.000	65.86	Peak	V	120	156	-39.64	-20	19.64
2605.500	64.98	Peak	V	100	44	-36.65	-20	16.65
4342.500	63.54	Peak	V	100	138	-38.71	-20	18.71
...	...		V			...		

Modulation		4FSK		Channel Separation		12.5KHz		
Test Channel		Low Channel		Test Frequency		896.5000 MHz		
Frequency (MHz)	E-Field Level (dBuv/m)	EMI Detector (Peak/QP)	Antenna Polarization	Antenna Height (cm)	Table Angle (Degree)	ERP measured by Substitution Method (dBm)	Limit (dBm)	Margin (dB)
1793.000	66.22	Peak	H	150	327	-39.28	-20	19.28
2689.500	63.07	Peak	H	100	55	-38.56	-20	18.56
4482.500	61.53	Peak	H	100	77	-40.72	-20	20.72
...	...		H					
1793.000	66.01	Peak	V	120	88	-39.49	-20	19.49
2689.500	64.78	Peak	V	100	155	-36.85	-20	16.85
4482.500	62.17	Peak	V	100	22	-40.08	-20	20.08
...	...		V			...		

Modulation		4FSK		Channel Separation		12.5KHz		
Test Channel		High Channel		Test Frequency		900.5000 MHz		
Frequency (MHz)	E-Field Level (dBuv/m)	EMI Detector (Peak/QP)	Antenna Polarization	Antenna Height (cm)	Table Angle (Degree)	ERP measured by Substitution Method (dBm)	Limit (dBm)	Margin (dB)
1801.000	66.33	Peak	H	130	360	-39.17	-20	19.17
2701.500	64.47	Peak	H	100	42	-37.16	-20	17.16
3602.000	62.30	Peak	H	100	55	-39.95	-20	19.95
...	...		H					
1801.000	65.86	Peak	V	150	44	-39.64	-20	19.64
2701.500	62.74	Peak	V	100	125	-38.89	-20	18.89
3602.000	63.42	Peak	V	120	335	-38.83	-20	18.83
...	...		V			...		

Modulation		4FSK		Channel Separation		12.5KHz		
Test Channel		Low Channel		Test Frequency		935.5000 MHz		
Frequency (MHz)	E-Field Level (dBuv/m)	EMI Detector (Peak/QP)	Antenna Polarization	Antenna Height (cm)	Table Angle (Degree)	ERP measured by Substitution Method (dBm)	Limit (dBm)	Margin (dB)
1871.000	65.87	Peak	H	100	243	-39.63	-20	19.63
2806.500	63.64	Peak	H	120	12	-37.99	-20	17.99
4677.500	63.24	Peak	H	120	101	-39.01	-20	19.01
...	...		H					
1871.000	65.90	Peak	V	100	202	-39.60	-20	19.60
2806.500	62.07	Peak	V	100	177	-39.56	-20	19.56
4677.500	63.53	Peak	V	150	52	-38.72	-20	18.72
...	...		V			...		

Modulation		4FSK		Channel Separation		12.5KHz		
Test Channel		High Channel		Test Frequency		939.5000 MHz		
Frequency (MHz)	E-Field Level (dBuv/m)	EMI Detector (Peak/QP)	Antenna Polarization	Antenna Height (cm)	Table Angle (Degree)	ERP measured by Substitution Method (dBm)	Limit (dBm)	Margin (dB)
1879.000	64.86	Peak	H	100	35	-40.64	-20	20.64
2818.500	63.07	Peak	H	100	147	-38.56	-20	18.56
4697.000	63.53	Peak	H	150	154	-38.72	-20	18.72
...	...		H					
1879.000	65.86	Peak	V	100	34	-39.64	-20	19.64
2818.500	63.05	Peak	V	120	230	-38.58	-20	18.58
4697.000	61.06	Peak	V	120	255	-41.19	-20	21.19
...	...		V			...		

4.4. Spurious Emission on Antenna Port

TEST APPLICABLE

The same as Section 4.3

TEST PROCEDURE

The RF output of the EUT was connected to a spectrum analyzer through appropriate attenuation. The resolution bandwidth of the spectrum analyzer was set to 100 kHz. Sufficient scans were taken to show any out of band emission up to 10th. Harmonic for the lower and the highest frequency range. Set RBW 100 kHz, VBW 300 kHz in the frequency band 30MHz to 1GHz, while set RBW=1MHz, VBW=3MHz from the 1GHz to 10th Harmonic.

The audio input was set to 0 to get the unmodulated carrier, the resulting picture is print out for each channel separation.

TEST CONFIGURATION

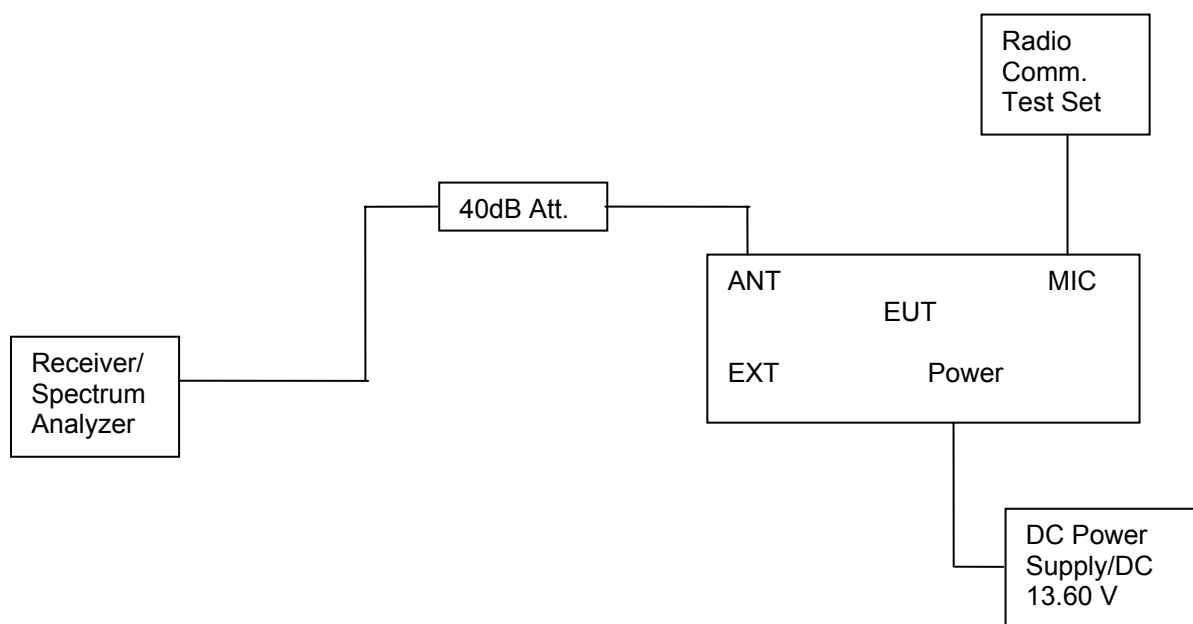

TEST RESULTS

Modulation Type: FM

FCC Part 22.359, 74.462, 80.211 and 90.210 and RSS Gen, RSS 119 Issue 11 (25 kHz bandwidth only):

On any frequency removed from the center of the assigned channel by more than 250 percent at least:

High: $43 + 10 \log (P_{\text{watts}}) = 43 + 10 \log (3.288) = 48.17 \text{ dB}$

Low: $43 + 10 \log (P_{\text{watts}}) = 43 + 10 \log (3.012) = 47.79 \text{ dB}$

Calculation: Limit (dBm) = EL - 43 - 10log₁₀ (TP)

Notes: EL is the emission level of the Output Power expressed in dBm,

In this application, the EL is 35.17 dBm.

Limit (dBm) = 35.17 - 43 - 10log₁₀ (3.288) = -13 dBm

FCC Part 22.359, 74.462, 80.211 and 90.210 and RSS Gen, RSS 119 Issue 11 (12.5 kHz bandwidth only): On any frequency removed from the center of the authorized bandwidth by a displacement frequency (f_d in kHz) of more than 12.5 kHz at least:

High: $50 + 10 \log (P_{\text{watts}}) = 50 + 10 \log (3.319) = 55.21 \text{ dB}$

Low: $50 + 10 \log (P_{\text{watts}}) = 50 + 10 \log (3.069) = 54.87 \text{ dB}$

Note: In general, the worse case attenuation requirement shown above was applied.

Calculation: Limit (dBm) = EL - 50 - 10log₁₀ (TP)

Notes: EL is the emission level of the Output Power expressed in dBm,

In this application, the EL is 35.21 dBm.

Limit (dBm) = 35.21 - 50 - 10log₁₀ (3.319) = -20 dBm

Modulation Type: 4FSK

FCC Part 22.359, 74.462, 80.211 and 90.210 and RSS Gen, RSS 119 Issue 11 (12.5 kHz Bandwidth only):
 On any frequency removed from the center of the authorized bandwidth by a displacement frequency (f d in kHz) of more than 12.5 kHz at least:

High: $50 + 10 \log (P_{\text{watts}}) = 50 + 10 \log (3.334) = 55.23 \text{ dB}$

Low: $50 + 10 \log (P_{\text{watts}}) = 50 + 10 \log (3.090) = 54.90 \text{ dB}$

Note: In general, the worse case attenuation requirement shown above was applied.

Calculation: $\text{Limit (dBm)} = \text{EL} - 50 - 10 \log_{10} (\text{TP})$

Notes: EL is the emission level of the Output Power expressed in dBm,
 In this application, the EL is 25.23 dBm.

Limit (dBm) = $25.23 - 50 - 10 \log_{10} (3.334) = -20 \text{ dBm}$

Note: 1. In general, the worse case attenuation requirement shown above was applied.

2. The measurement frequency range from 30MHz to 10 GHz.

For Rated High Power (3Watt)

Frequency Range (MHz)	Modulation Type	Channel Separation (KHz)	Test Channel	Maximum Conducted Spurious Emissions (dBm)			
				Below 1GHz		Above 1GHz	
				Frequency (MHz)	Datum (dBm)	Frequency (MHz)	Datum (dBm)
806-825	Analog/FM	25	Low	638.05	-29.23	1612.00	-27.34
			Middle	744.66	-29.86	1630.00	-28.07
			High	859.99	-30.03	1648.00	-28.75
		12.5	Low	478.99	-29.06	1612.00	-27.49
			Middle	841.06	-29.25	3196.00	-25.00
			High	855.66	-29.60	3196.00	-25.55
	Digital/4FSK	12.5	Low	870.00	-29.72	9640.00	-25.65
			Middle	873.56	-29.52	7858.00	-25.52
			High	873.05	-29.36	3106.00	-25.29
851-870	Analog/FM	25	Low	897.18	-29.40	3178.00	-24.95
			Middle	920.46	-29.43	3106.00	-25.57
			High	972.84	-29.21	3628.00	-25.86
		12.5	Low	885.65	-29.30	3178.00	-25.44
			Middle	922.24	-29.63	3160.00	-25.47
			High	689.06	-29.12	3646.00	-25.38
	Digital/4FSK	12.5	Low	637.24	-29.52	3106.00	-25.63
			Middle	973.11	-29.63	3268.00	-26.08
			High	687.20	-28.96	3016.00	-25.08
896-902	Analog/FM	12.5	Low	688.52	-28.26	3142.00	-25.60
			High	775.35	-28.59	3232.00	-25.88
	Digital/4FSK		Low	786.97	-29.63	3052.00	-24.56
			High	367.21	-29.65	8560.00	-25.53
935-941	Analog/FM	12.5	Low	869.75	-29.56	3106.00	-25.11
			High	900.86	-29.17	9226.00	-25.62
	Digital/4FSK		Low	973.21	-29.85	3124.00	-25.83
			High	680.21	-29.06	3160.00	-25.59
Limit		-13dBm for 25KHz Channel Separation					
		-20dBm for 12.5KHz Channel Separation					
Test Results		Compliance					

For Rated Low Power (1Watt)

Frequency Range (MHz)	Modulation Type	Channel Separation (KHz)	Test Channel	Maximum Conducted Spurious Emissions (dBm)			
				Below 1GHz		Above 1GHz	
				Frequency (MHz)	Datum (dBm)	Frequency (MHz)	Datum (dBm)
806-825	Analog/FM	25	Low	687.33	-29.78	3106.00	-24.90
			Middle	869.79	-29.56	3178.00	-25.35
			High	753.21	-28.95	8596.00	-25.65
		12.5	Low	690.25	-28.96	3178.00	-25.46
			Middle	693.47	-28.56	3142.00	-25.82
			High	693.52	-29.24	9262.00	25.74
	Digital/4FSK	12.5	Low	874.21	-29.06	3124.00	-25.38
			Middle	568.54	-29.85	9226.00	-25.67
			High	653.52	-28.99	3070.00	-26.43
851-870	Analog/FM	25	Low	932.10	-28.83	3142.00	-25.26
			Middle	910.76	-29.88	9928.00	-26.23
			High	986.42	-28.28	3178.00	-26.05
		12.5	Low	683.21	-29.14	3178.00	-25.53
			Middle	795.21	-29.45	3286.00	-26.50
			High	963.22	-29.54	9082.00	-25.74
	Digital/4FSK	12.5	Low	886.54	-29.88	9244.00	-27.75
			Middle	635.55	-28.95	3124.00	-25.87
			High	785.22	-28.95	3574.00	-25.79
896-902	Analog/FM	12.5	Low	683.20	-28.96	8524.00	-25.90
			High	665.24	-29.78	8506.00	-25.36
	Digital/4FSK		Low	976.54	-28.96	3070.00	-25.60
			High	753.52	-29.55	8524.00	-26.20
935-941	Analog/FM	12.5	Low	986.22	-29.55	9586.00	-25.20
			High	638.54	-29.44	3196.00	-25.56
	Digital/4FSK		Low	654.21	-28.92	9064.00	-26.01
			High	856.02	-28.93	9208.00	-26.61
Limit		-13dBm for 25KHz Channel Separation					
		-20dBm for 12.5KHz Channel Separation					
Test Results		Compliance					

Plots of Spurious Emission on Antenna Port Measurement

For Rated High Power (3Watt)

Modulation Type	Channel Sparation	Test Channel	Test Frequency (MHz)	Maximum Conducted Spurious Emissions Below 1GHz		Maximum Conducted Spurious Emissions Above 1GHz		FCC Limit
				Frequency (MHz)	Datum (dBm)	Frequency (MHz)	Datum (dBm)	
FM	25KHz	Low	806.5000	638.05	-29.23	1612.00	-27.34	-13dBm
Test Results				Compliance				

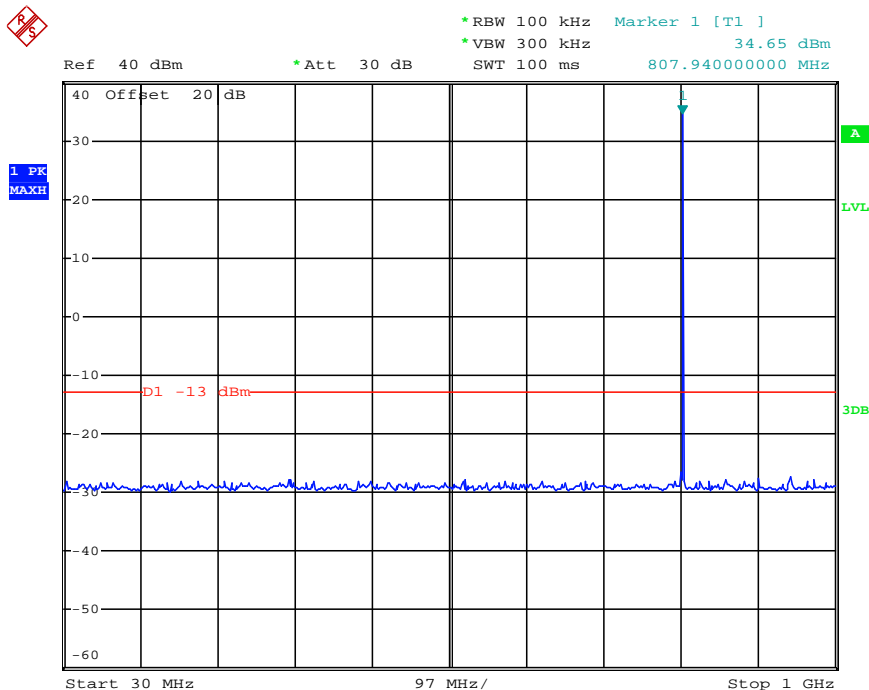

Date: 1.APR.2013 18:21:10

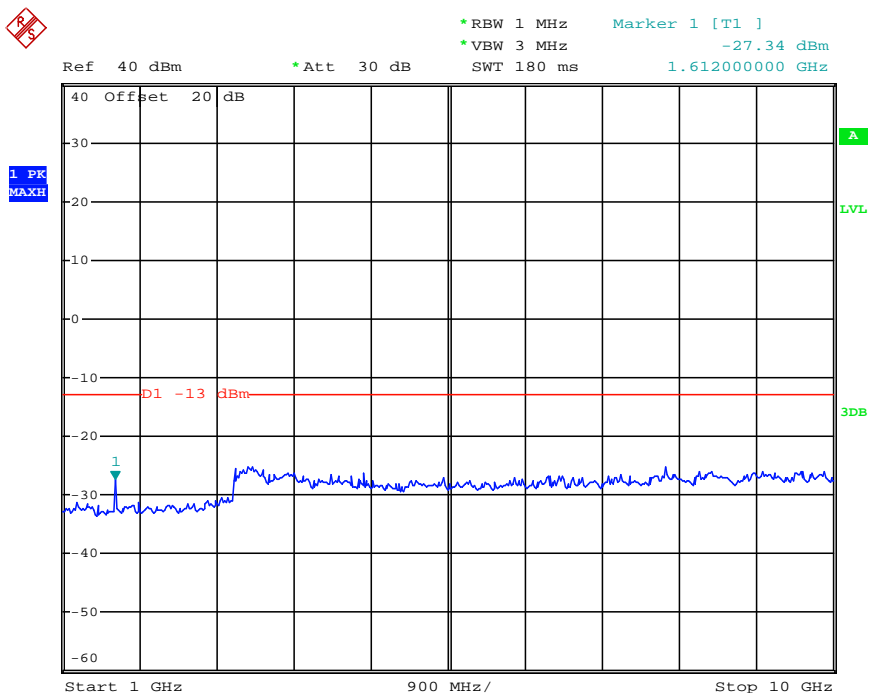

Date: 1.APR.2013 18:22:15

Modulation Type	Channel Sparation	Test Channel	Test Frequency (MHz)	Maximum Conducted Spurious Emissions Below 1GHz		Maximum Conducted Spurious Emissions Above 1GHz		FCC Limit
				Frequency (MHz)	Datum (dBm)	Frequency (MHz)	Datum (dBm)	
FM	25KHz	Middle	817.0000	744.66	-29.86	1630.00	-28.07	-13dBm
Test Results				Compliance				

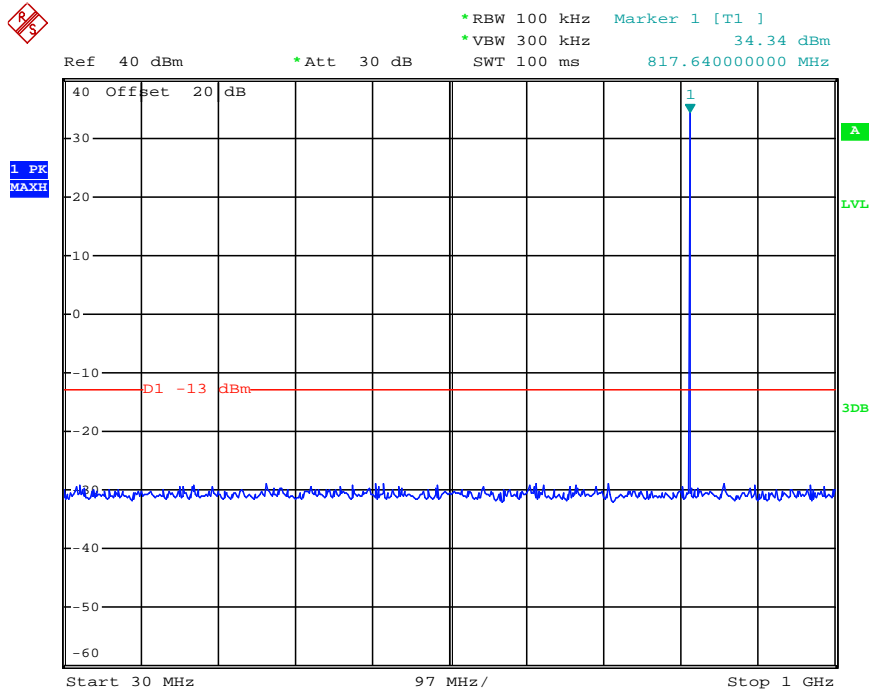

Date: 1.APR.2013 18:23:51

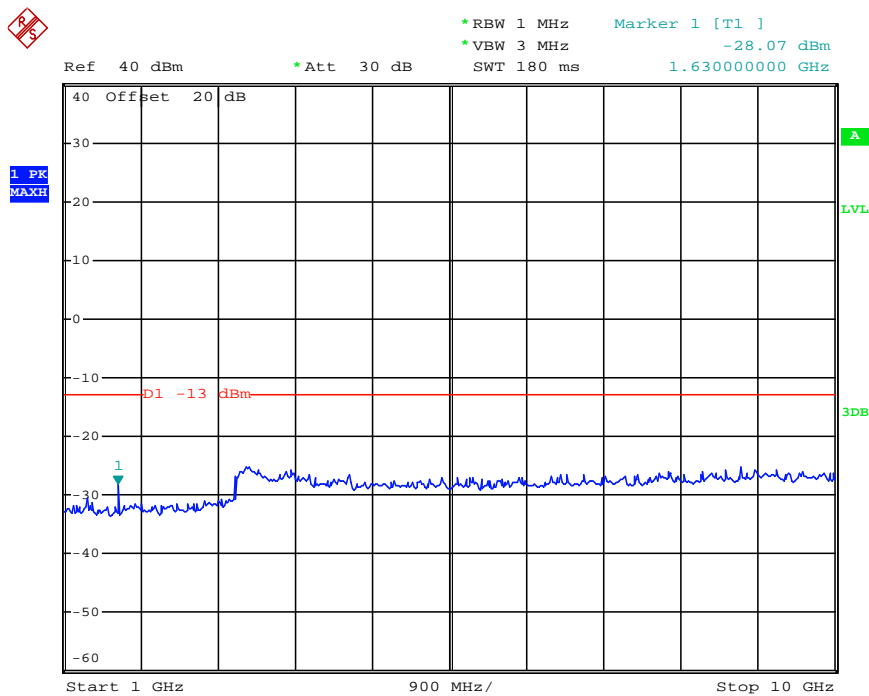

Date: 1.APR.2013 18:23:11

Modulation Type	Channel Sparation	Test Channel	Test Frequency (MHz)	Maximum Conducted Spurious Emissions Below 1GHz		Maximum Conducted Spurious Emissions Above 1GHz		FCC Limit
				Frequency (MHz)	Datum (dBm)	Frequency (MHz)	Datum (dBm)	
FM	25KHz	High	823.5000	859.99	-30.03	1648.00	-28.75	-13dBm
Test Results				Compliance				

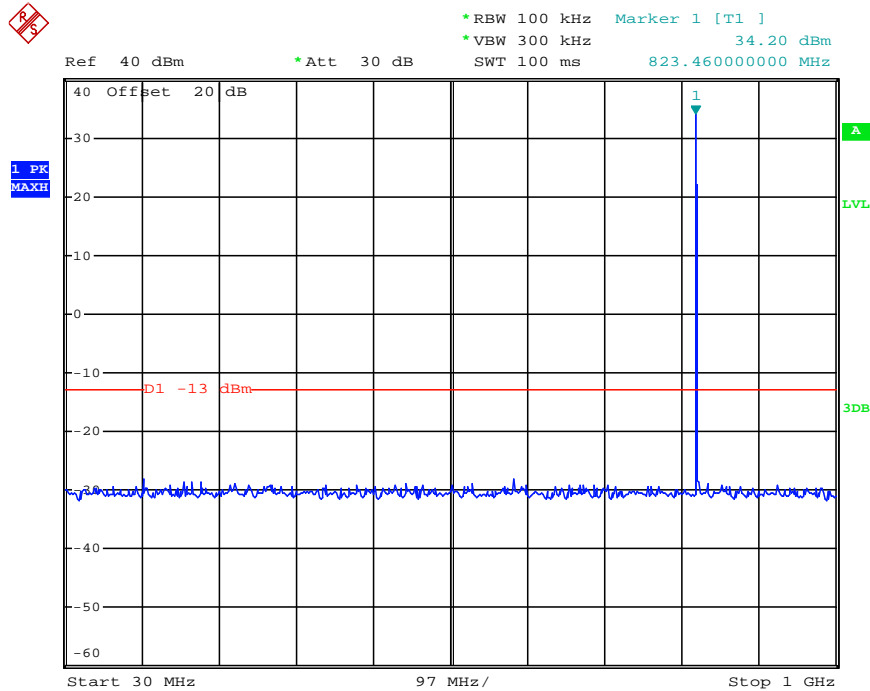

Date: 1.APR.2013 18:24:28

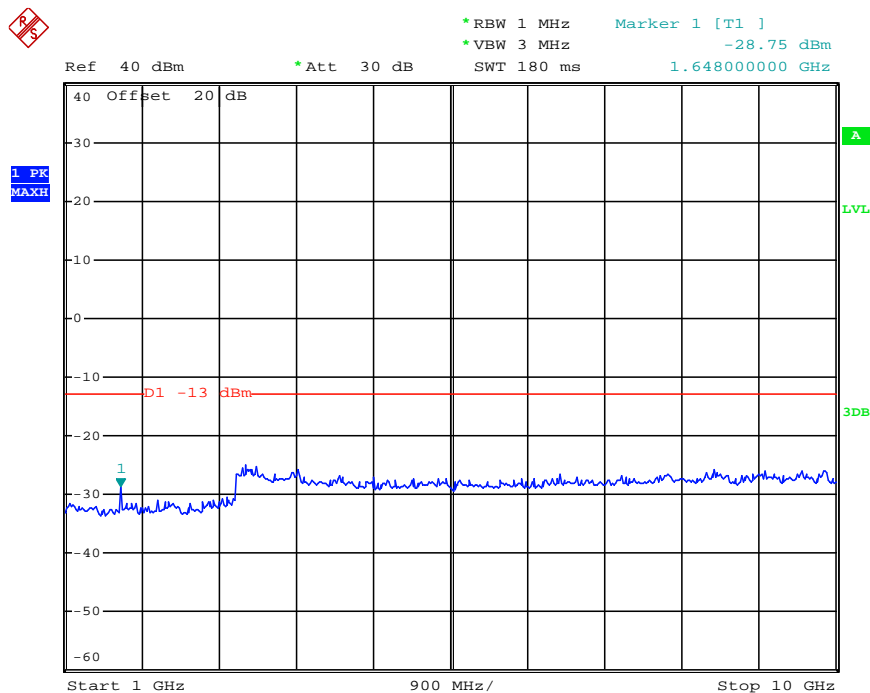

Date: 1.APR.2013 18:25:18

Modulation Type	Channel Sparation	Test Channel	Test Frequency (MHz)	Maximum Conducted Spurious Emissions Below 1GHz		Maximum Conducted Spurious Emissions Above 1GHz		FCC Limit
				Frequency (MHz)	Datum (dBm)	Frequency (MHz)	Datum (dBm)	
FM	25KHz	Low	851.5000	897.18	-29.40	3178.00	-24.95	-13dBm
Test Results				Compliance				

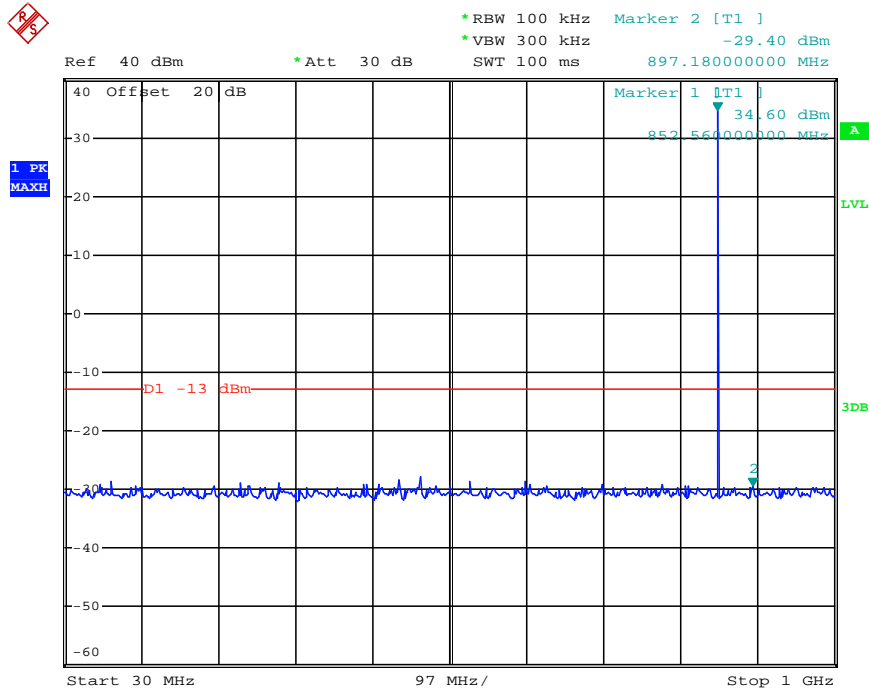

Date: 10.APR.2013 16:47:29

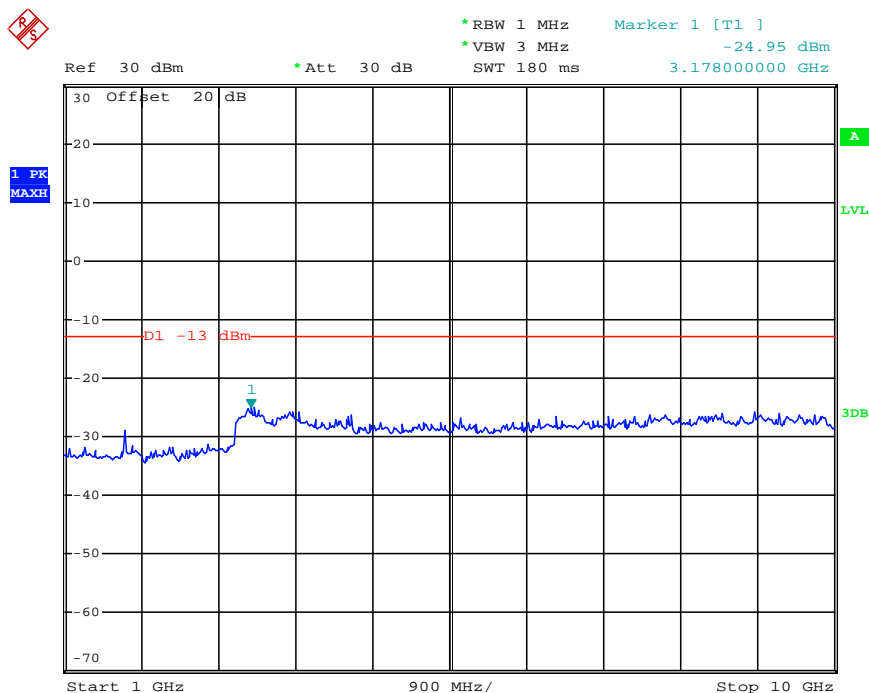

Date: 3.APR.2013 17:42:13

Modulation Type	Channel Sparation	Test Channel	Test Frequency (MHz)	Maximum Conducted Spurious Emissions Below 1GHz		Maximum Conducted Spurious Emissions Above 1GHz		FCC Limit
				Frequency (MHz)	Datum (dBm)	Frequency (MHz)	Datum (dBm)	
FM	25KHz	Middle	860.0000	920.46	-29.43	3106.00	-25.57	-13dBm
Test Results				Compliance				

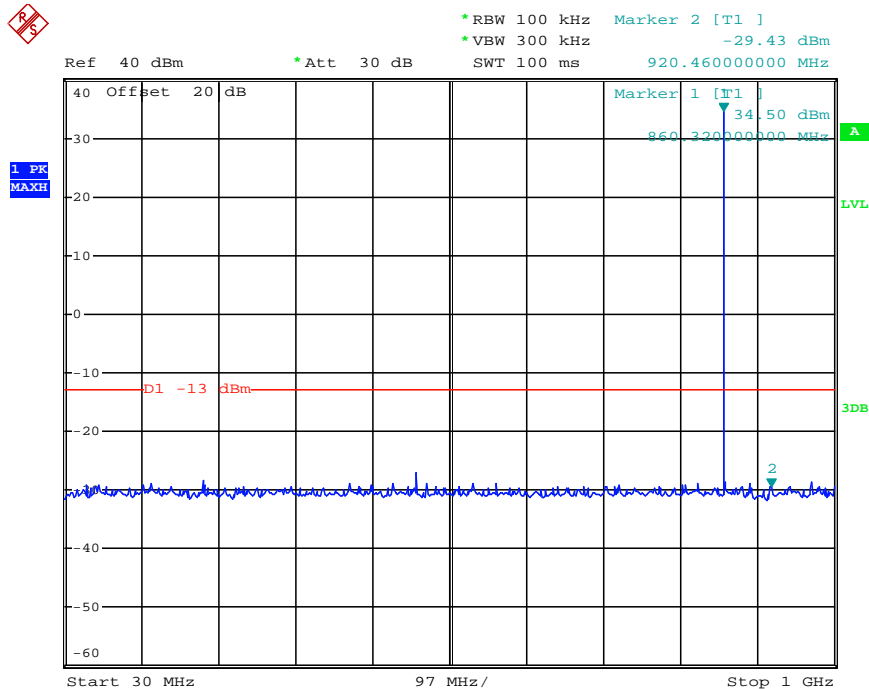

Date: 10.APR.2013 16:48:07

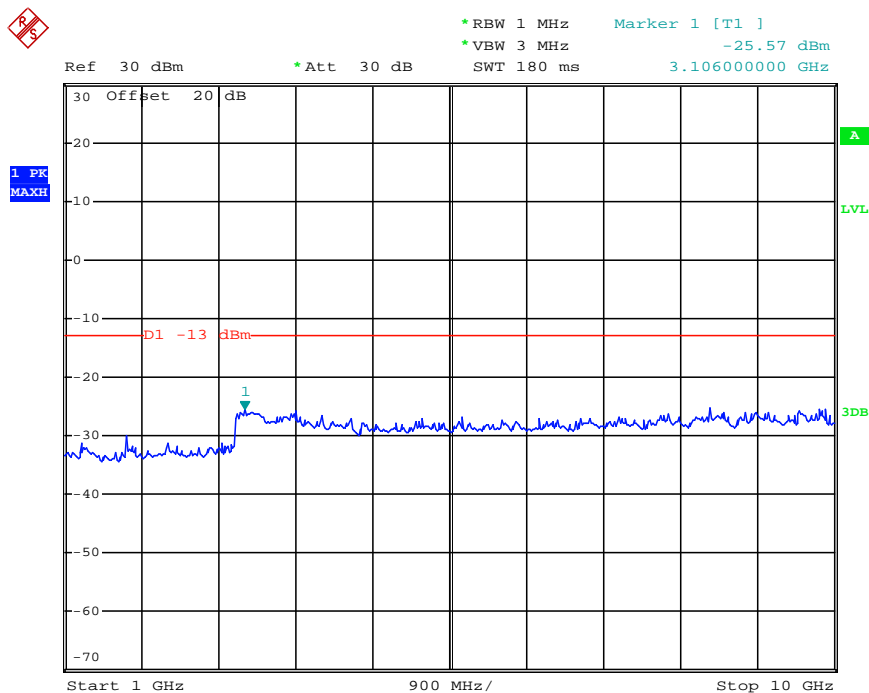

Date: 3.APR.2013 17:42:51

Modulation Type	Channel Sparation	Test Channel	Test Frequency (MHz)	Maximum Conducted Spurious Emissions Below 1GHz		Maximum Conducted Spurious Emissions Above 1GHz		FCC Limit
				Frequency (MHz)	Datum (dBm)	Frequency (MHz)	Datum (dBm)	
FM	25KHz	High	868.5000	972.84	-29.21	3628.00	-25.86	-13dBm
Test Results				Compliance				

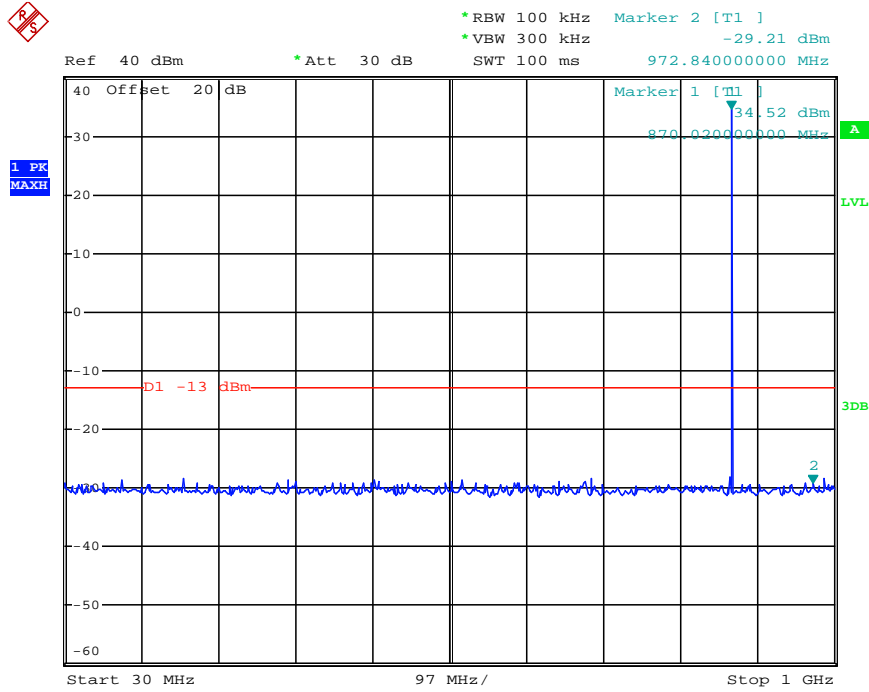

Date: 10.APR.2013 16:48:50

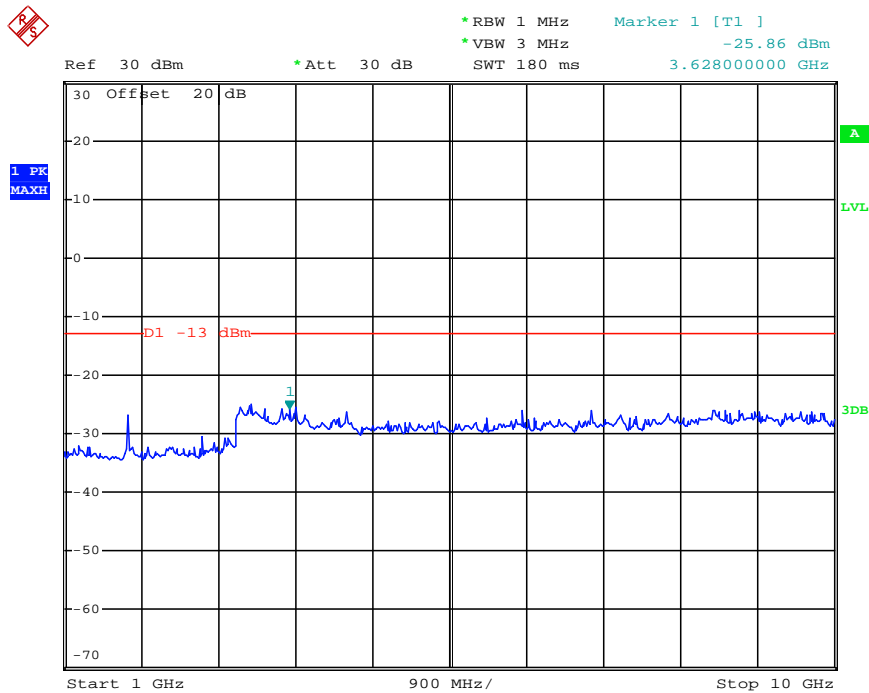

Date: 3.APR.2013 17:45:52

Modulation Type	Channel Sparation	Test Channel	Test Frequency (MHz)	Maximum Conducted Spurious Emissions Below 1GHz		Maximum Conducted Spurious Emissions Above 1GHz		FCC Limit
				Frequency (MHz)	Datum (dBm)	Frequency (MHz)	Datum (dBm)	
FM	12.5KHz	Low	806.5000	478.99	-29.06	1612.00	-27.49	-20dBm
Test Results				Compliance				

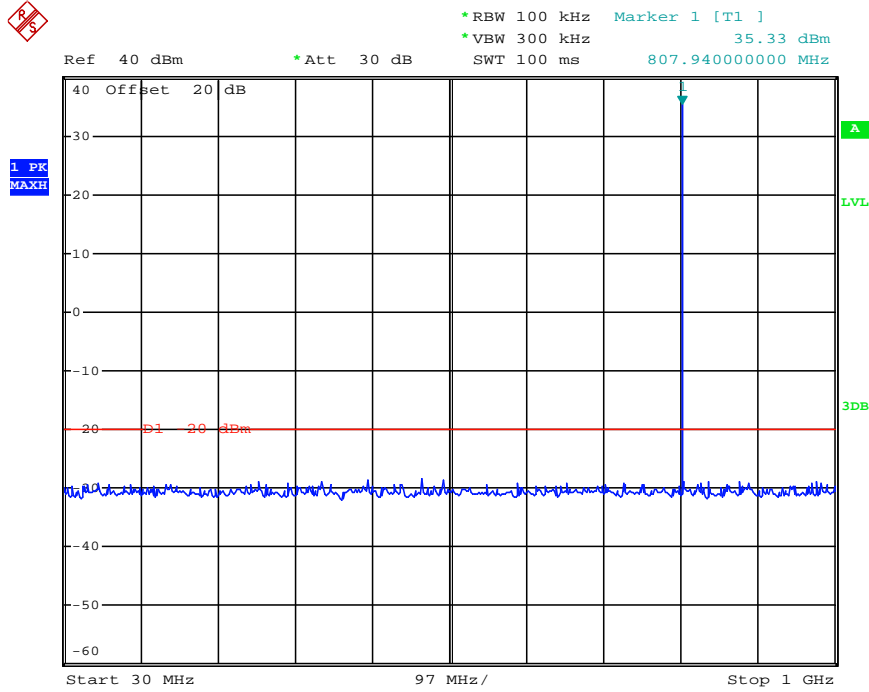

Date: 3.APR.2013 17:22:48

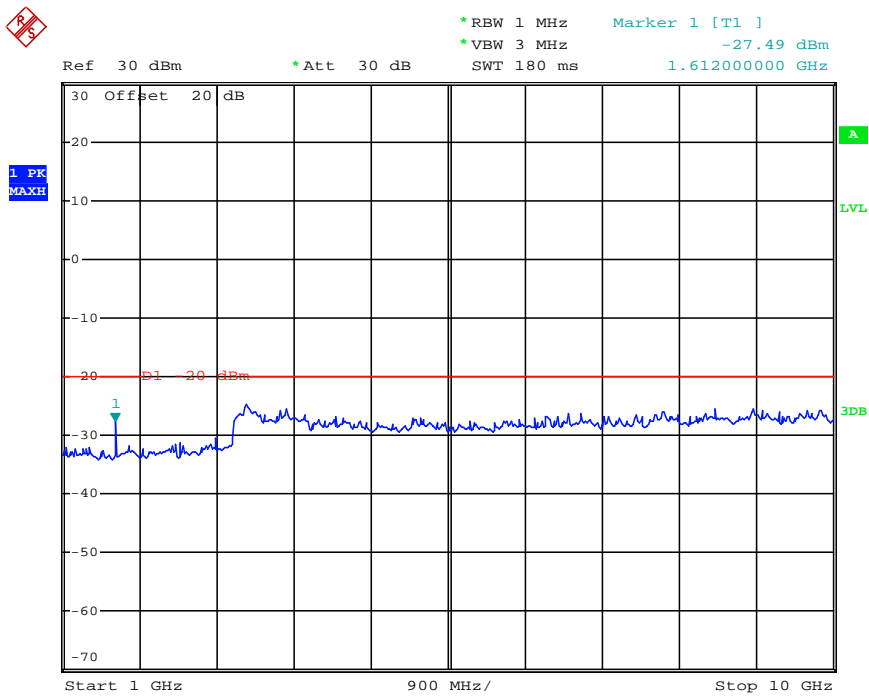

Date: 3.APR.2013 17:33:41

Modulation Type	Channel Sparation	Test Channel	Test Frequency (MHz)	Maximum Conducted Spurious Emissions Below 1GHz		Maximum Conducted Spurious Emissions Above 1GHz		FCC Limit
				Frequency (MHz)	Datum (dBm)	Frequency (MHz)	Datum (dBm)	
FM	12.5KHz	Middle	817.0000	841.06	-29.25	3196.00	-25.00	-20dBm
Test Results				Compliance				

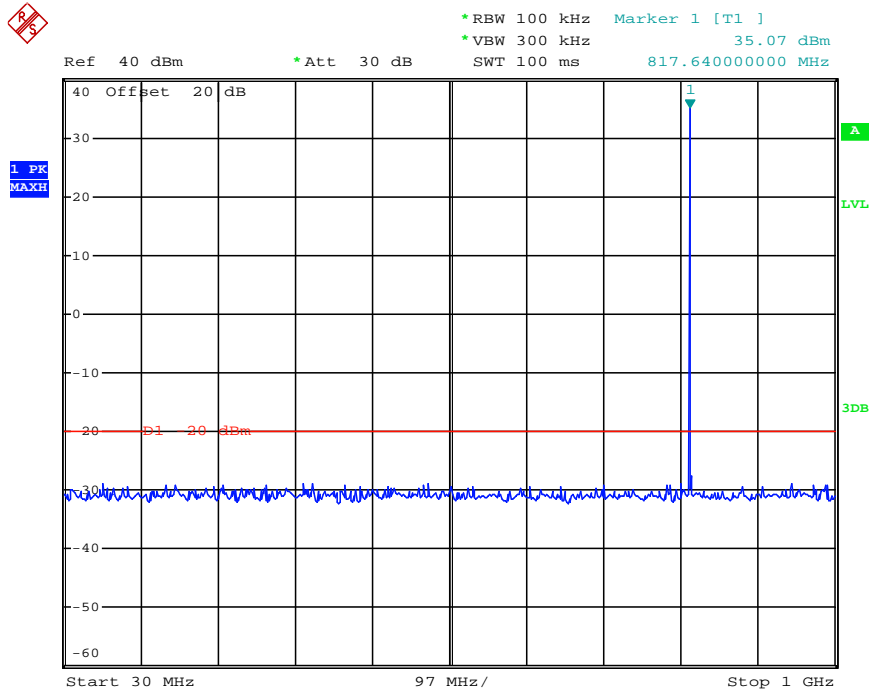

Date: 3.APR.2013 17:23:23

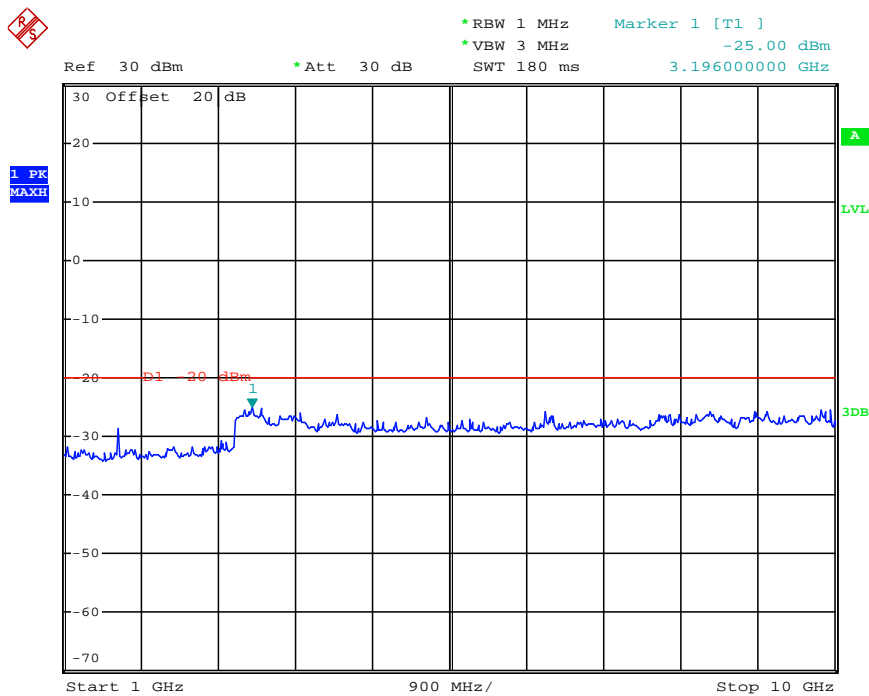

Date: 3.APR.2013 17:34:24

Modulation Type	Channel SpARATION	Test Channel	Test Frequency (MHz)	Maximum Conducted Spurious Emissions Below 1GHz		Maximum Conducted Spurious Emissions Above 1GHz		FCC Limit
				Frequency (MHz)	Datum (dBm)	Frequency (MHz)	Datum (dBm)	
FM	12.5KHz	High	823.5000	855.66	-29.60	3196.00	-25.55	-20dBm
Test Results				Compliance				

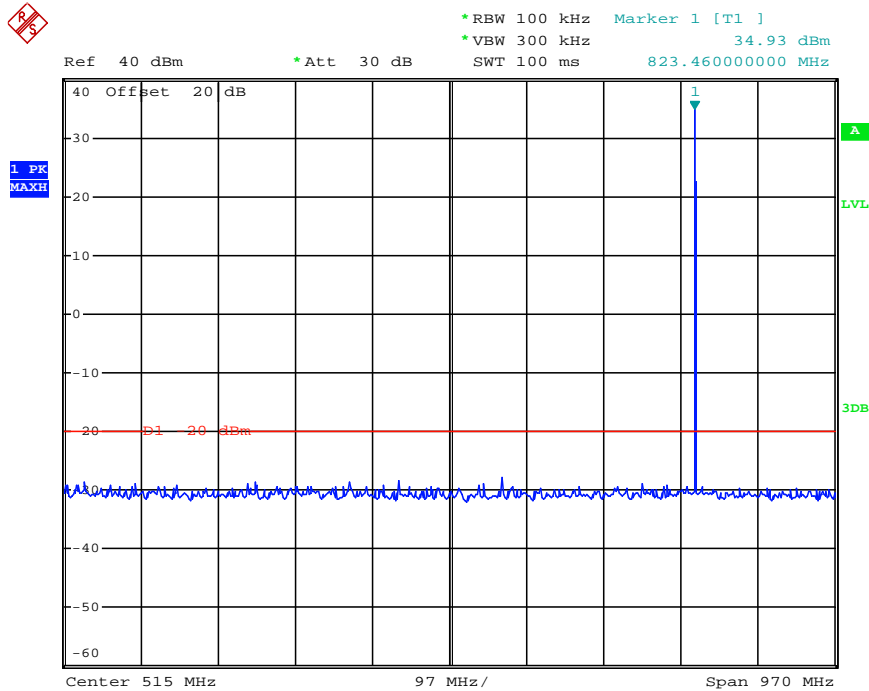

Date: 3.APR.2013 17:24:01

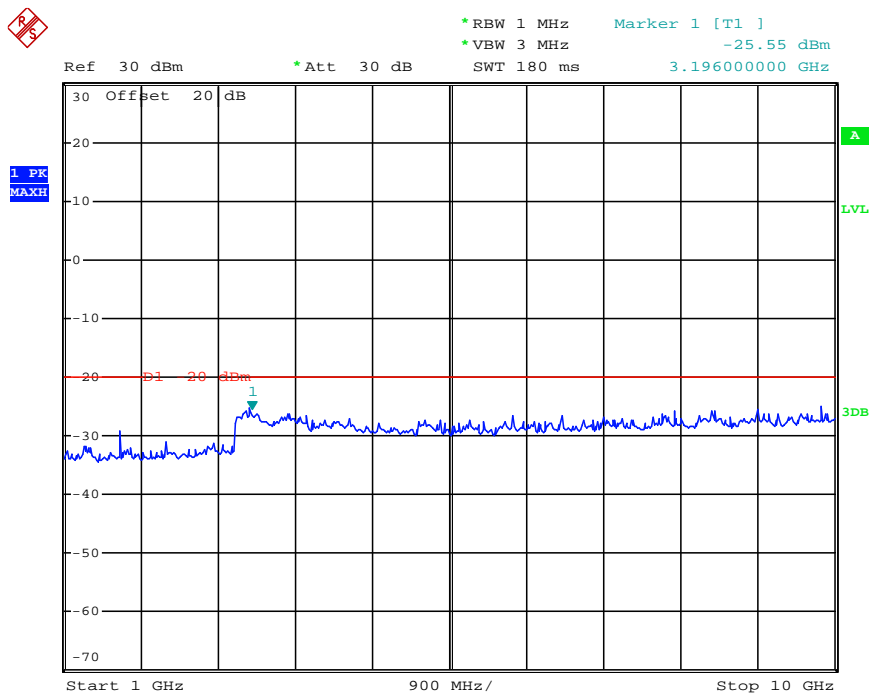

Date: 3.APR.2013 17:35:05

Modulation Type	Channel Sparation	Test Channel	Test Frequency (MHz)	Maximum Conducted Spurious Emissions Below 1GHz		Maximum Conducted Spurious Emissions Above 1GHz		FCC Limit
				Frequency (MHz)	Datum (dBm)	Frequency (MHz)	Datum (dBm)	
FM	12.5KHz	Low	851.5000	885.65	-29.30	3178.00	-25.44	-20dBm
Test Results				Compliance				

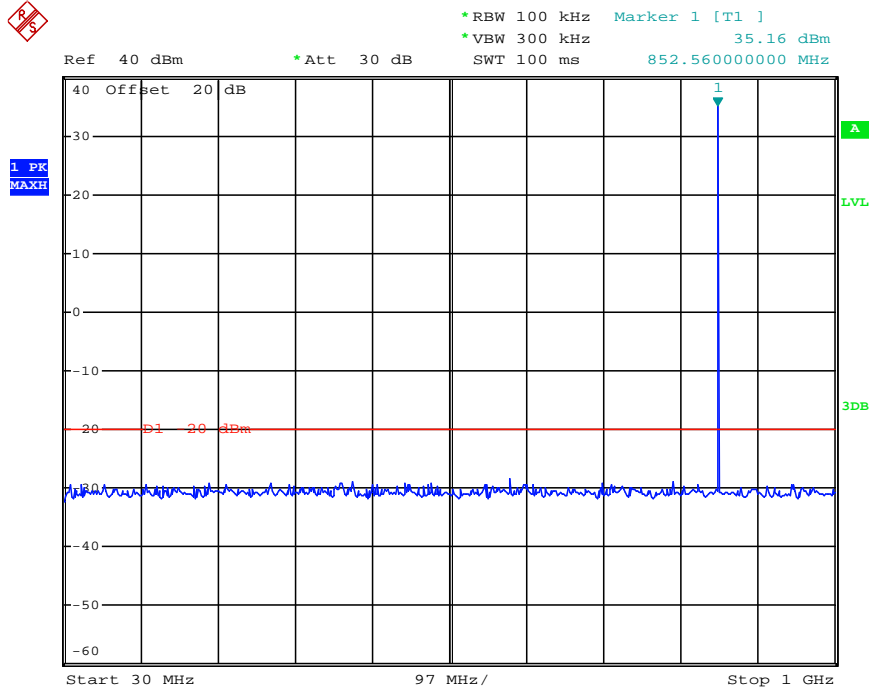

Date: 3.APR.2013 17:58:00

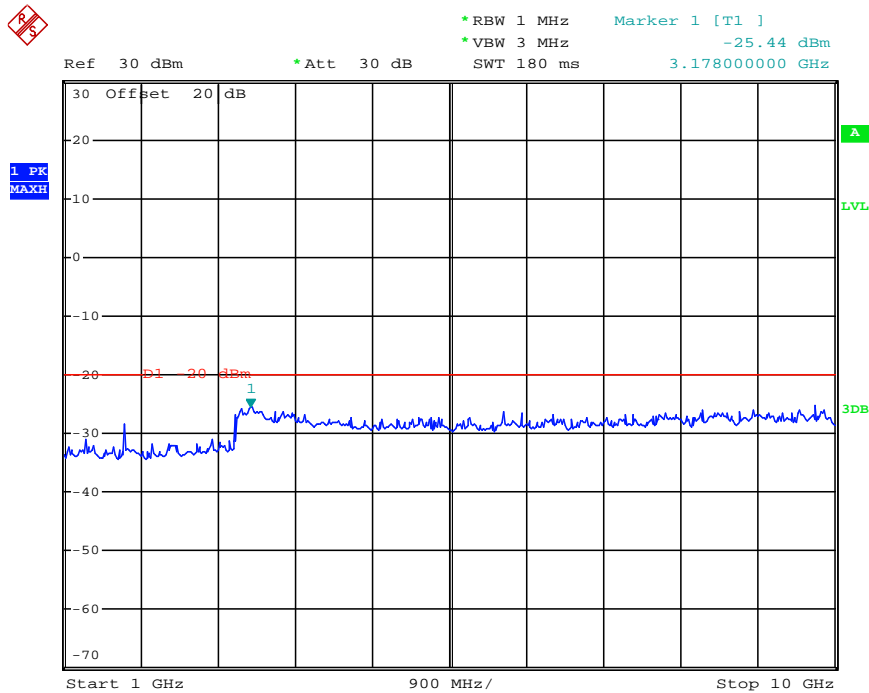

Date: 3.APR.2013 17:49:40

Modulation Type	Channel Sparation	Test Channel	Test Frequency (MHz)	Maximum Conducted Spurious Emissions Below 1GHz		Maximum Conducted Spurious Emissions Above 1GHz		FCC Limit
				Frequency (MHz)	Datum (dBm)	Frequency (MHz)	Datum (dBm)	
FM	12.5KHz	Middle	860.0000	922.24	-29.63	3160.00	-25.47	-20dBm
Test Results				Compliance				

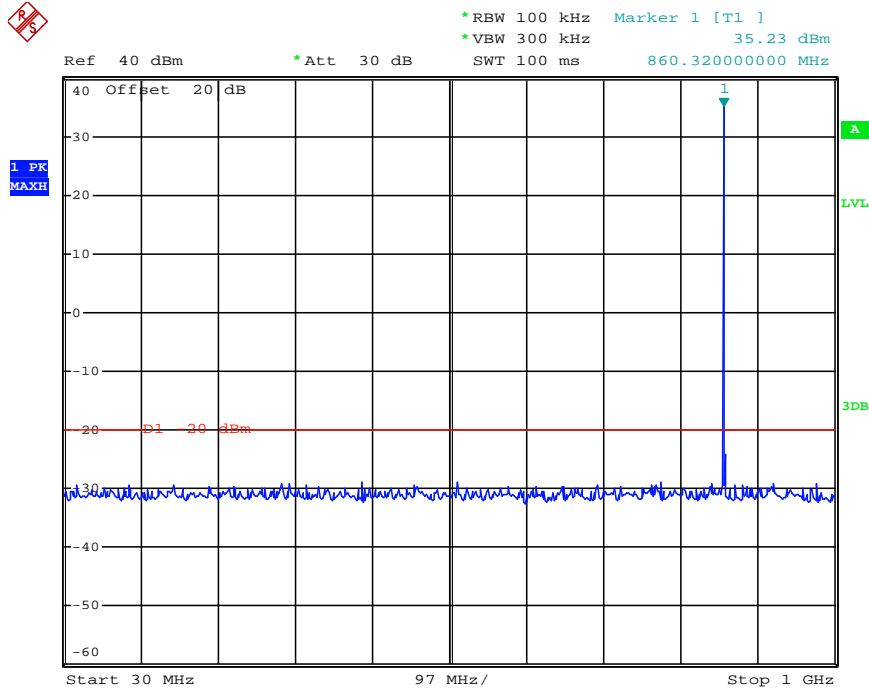

Date: 3.APR.2013 17:58:33

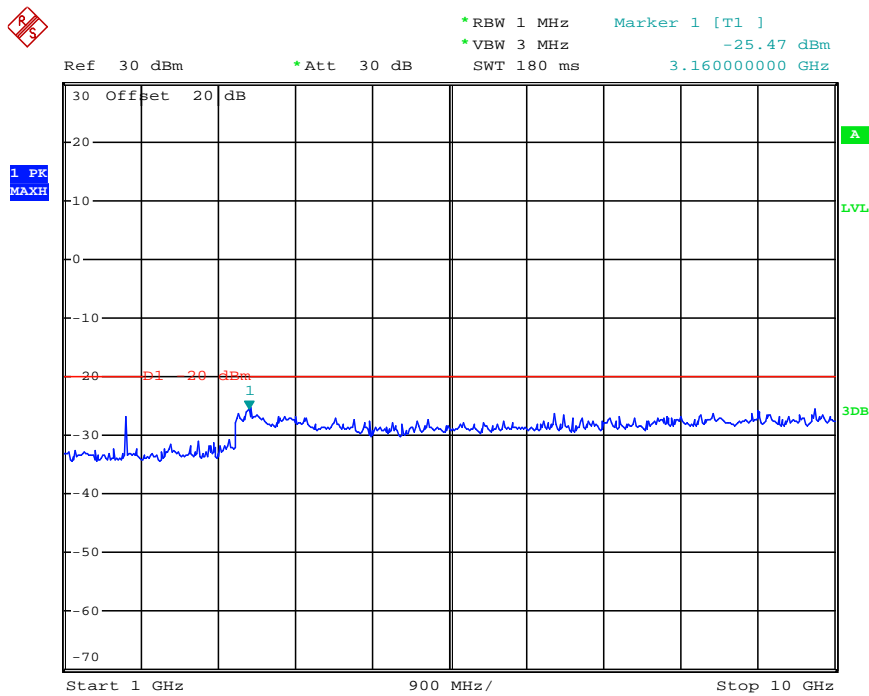

Date: 3.APR.2013 17:50:07

Modulation Type	Channel Sparation	Test Channel	Test Frequency (MHz)	Maximum Conducted Spurious Emissions Below 1GHz		Maximum Conducted Spurious Emissions Above 1GHz		FCC Limit
				Frequency (MHz)	Datum (dBm)	Frequency (MHz)	Datum (dBm)	
FM	12.5KHz	High	868.5000	689.06	-29.12	3646.00	-25.38	-20dBm
Test Results				Compliance				

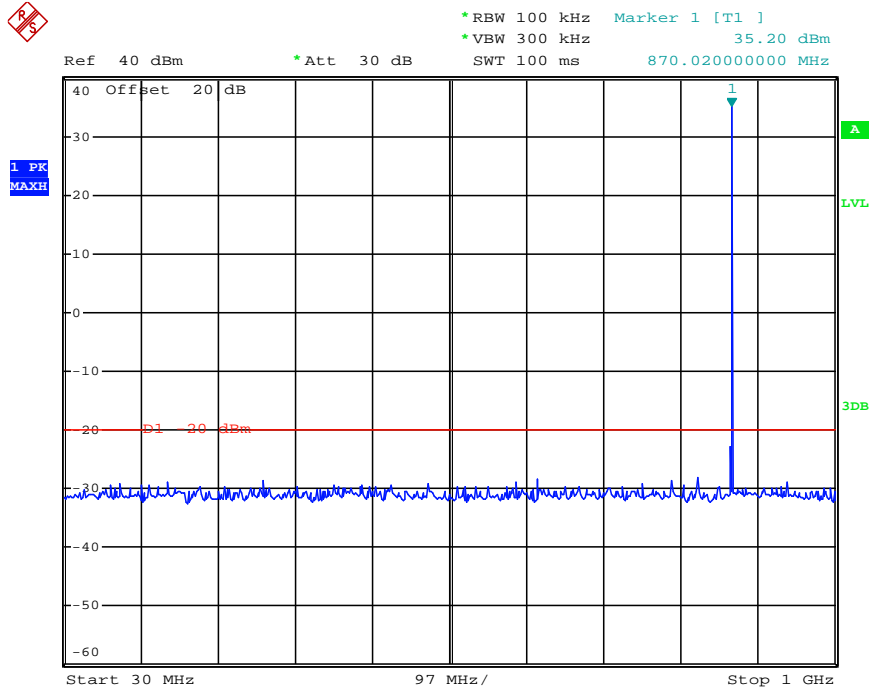

Date: 3.APR.2013 18:00:07

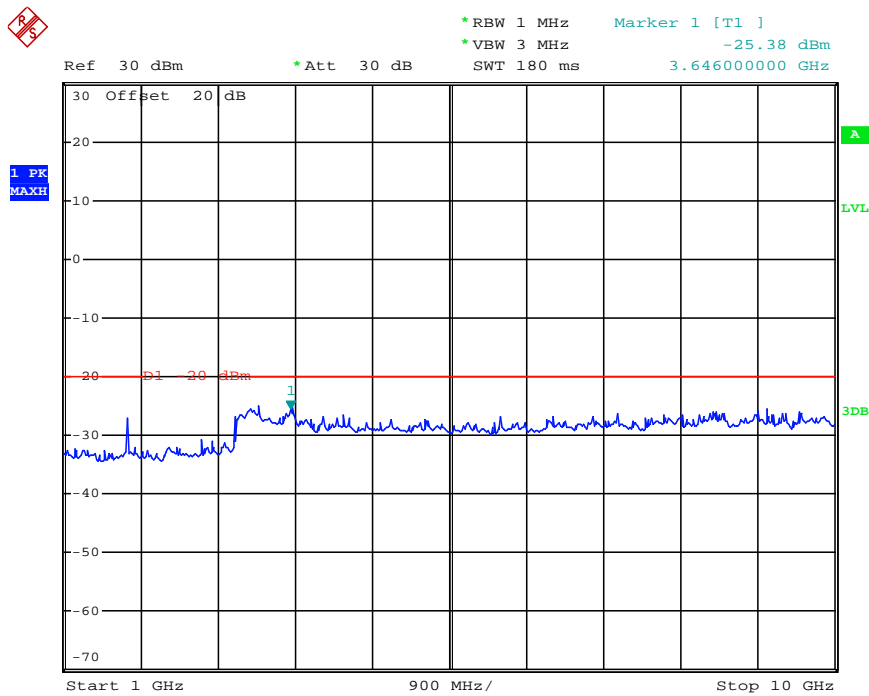

Date: 3.APR.2013 17:50:35

Modulation Type	Channel Sparation	Test Channel	Test Frequency (MHz)	Maximum Conducted Spurious Emissions Below 1GHz		Maximum Conducted Spurious Emissions Above 1GHz		FCC Limit
				Frequency (MHz)	Datum (dBm)	Frequency (MHz)	Datum (dBm)	
FM	12.5KHz	Low	896.5000	688.52	-28.26	3142.00	-25.60	-20dBm
Test Results				Compliance				

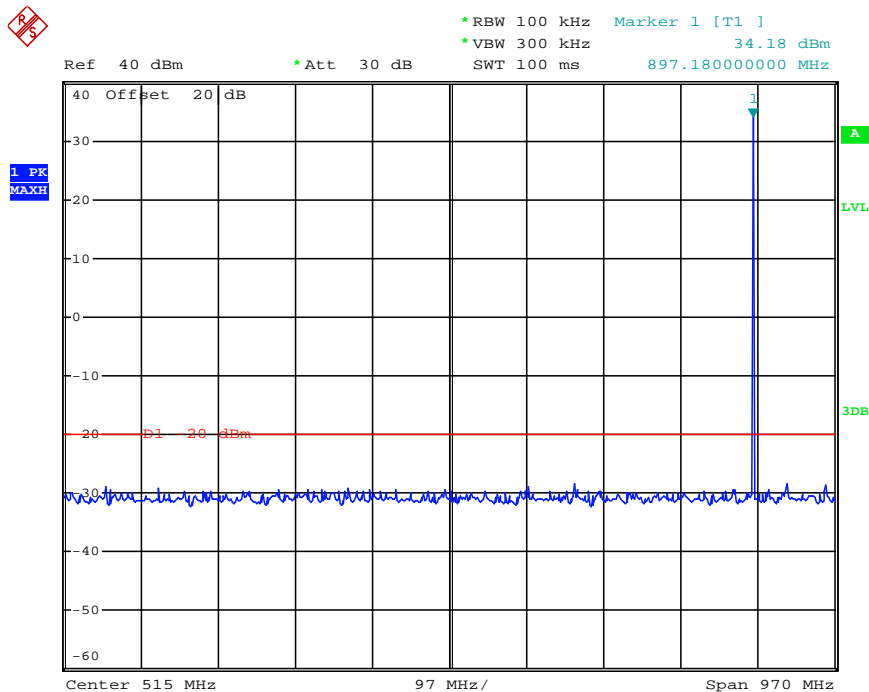

Date: 3.APR.2013 17:24:45

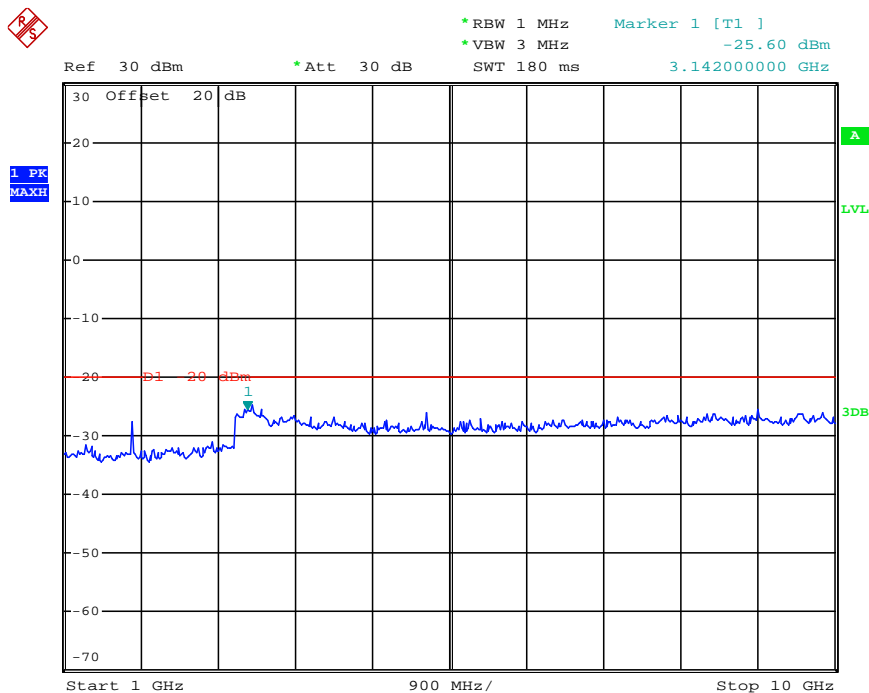

Date: 3.APR.2013 17:35:40

Modulation Type	Channel SpARATION	Test Channel	Test Frequency (MHz)	Maximum Conducted Spurious Emissions Below 1GHz		Maximum Conducted Spurious Emissions Above 1GHz		FCC Limit
				Frequency (MHz)	Datum (dBm)	Frequency (MHz)	Datum (dBm)	
FM	12.5KHz	High	900.5000	775.35	-28.59	3232.00	-25.88	-20dBm
Test Results				Compliance				

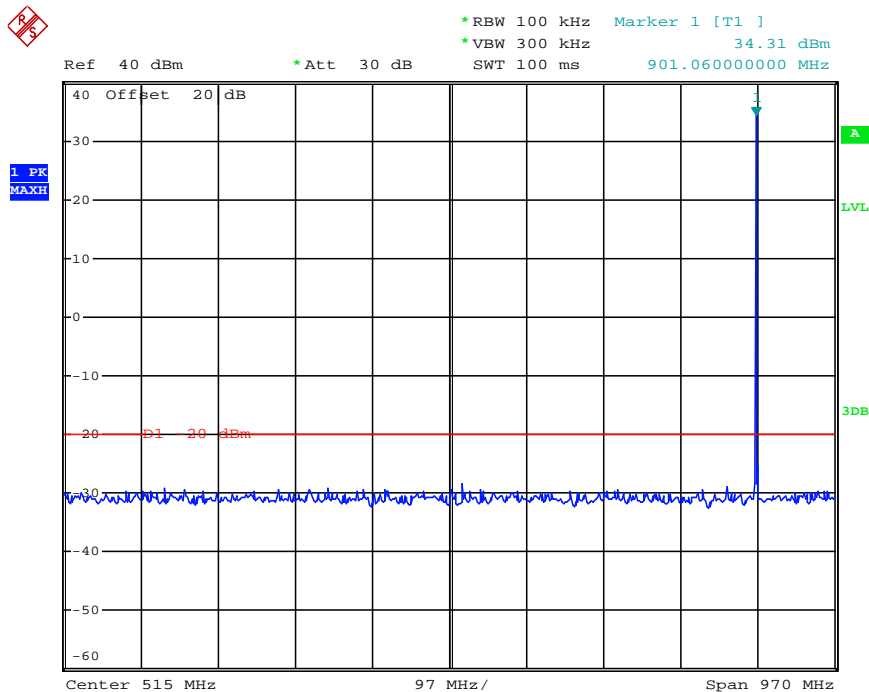

Date: 3.APR.2013 17:25:16

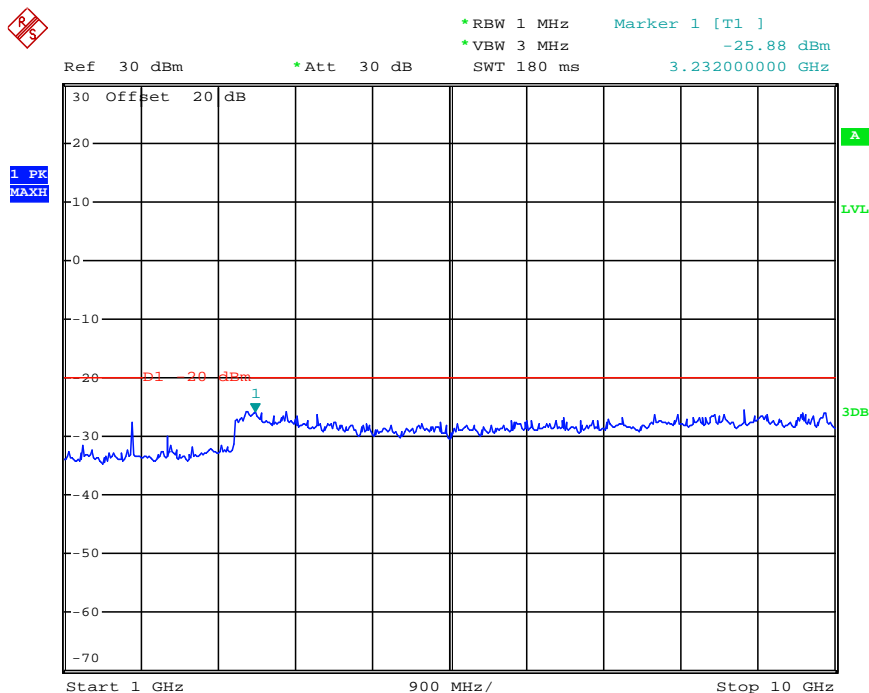

Date: 3.APR.2013 17:36:10

Modulation Type	Channel Sparation	Test Channel	Test Frequency (MHz)	Maximum Conducted Spurious Emissions Below 1GHz		Maximum Conducted Spurious Emissions Above 1GHz		FCC Limit
				Frequency (MHz)	Datum (dBm)	Frequency (MHz)	Datum (dBm)	
FM	12.5KHz	Low	935.5000	869.75	-29.56	3106.00	-25.11	-20dBm
Test Results				Compliance				

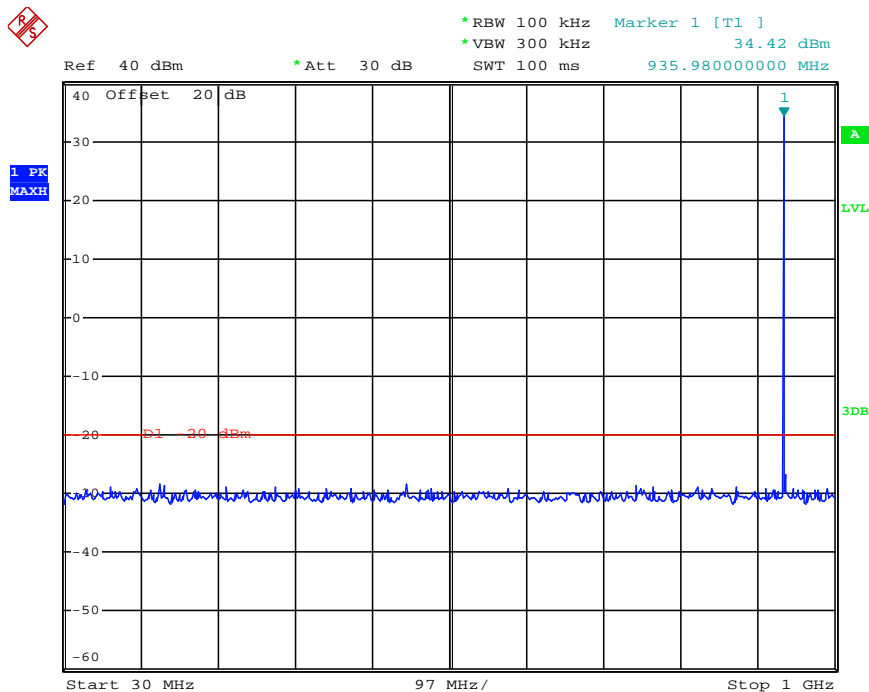

Date: 3.APR.2013 18:00:48

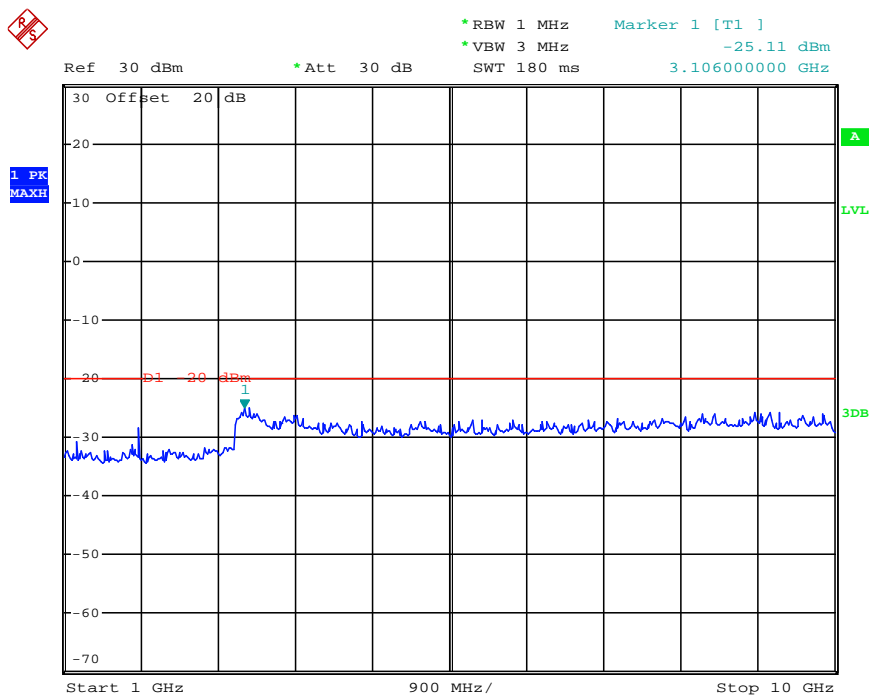

Date: 3.APR.2013 17:51:11

Modulation Type	Channel Sparation	Test Channel	Test Frequency (MHz)	Maximum Conducted Spurious Emissions Below 1GHz		Maximum Conducted Spurious Emissions Above 1GHz		FCC Limit
				Frequency (MHz)	Datum (dBm)	Frequency (MHz)	Datum (dBm)	
FM	12.5KHz	High	939.5000	900.86	-29.17	9226.00	-25.62	-20dBm
Test Results				Compliance				

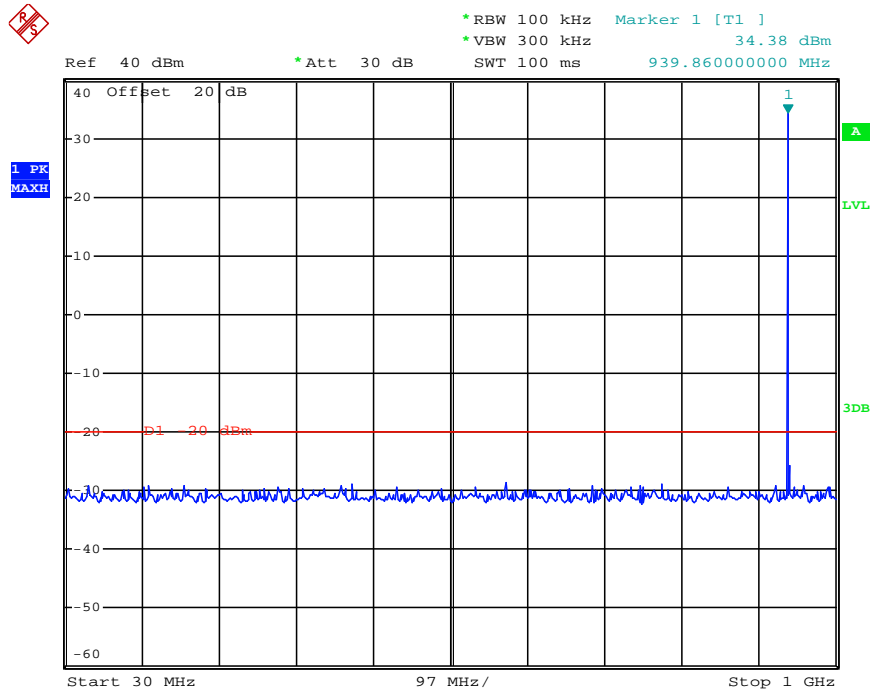

Date: 3.APR.2013 18:01:12

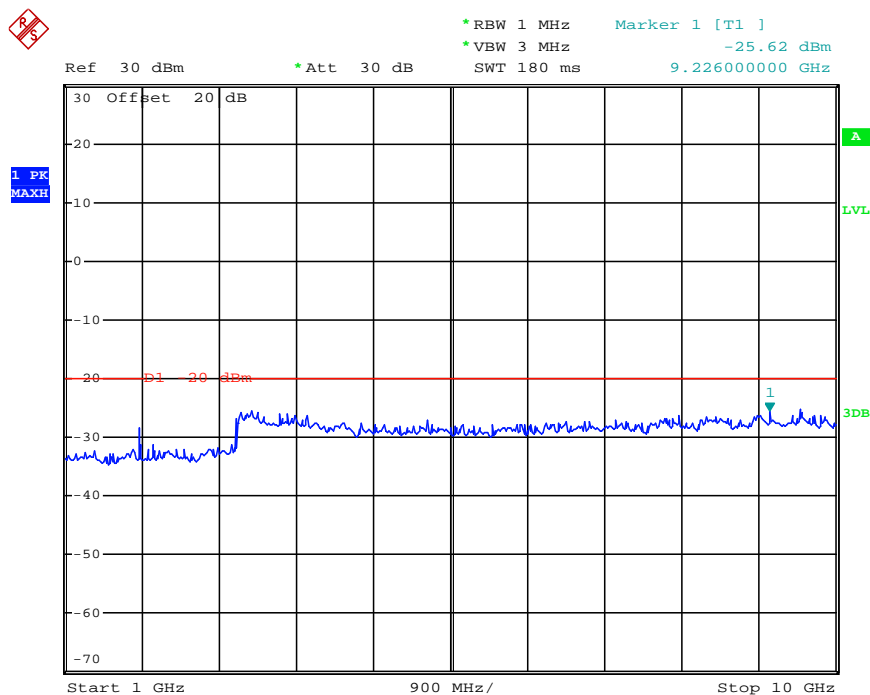

Date: 3.APR.2013 17:51:40

Modulation Type	Channel Sparation	Test Channel	Test Frequency (MHz)	Maximum Conducted Spurious Emissions Below 1GHz		Maximum Conducted Spurious Emissions Above 1GHz		FCC Limit
				Frequency (MHz)	Datum (dBm)	Frequency (MHz)	Datum (dBm)	
4FSK	12.5KHz	Low	806.5000	870.00	-29.72	9640.00	-25.65	-20dBm
Test Results				Compliance				

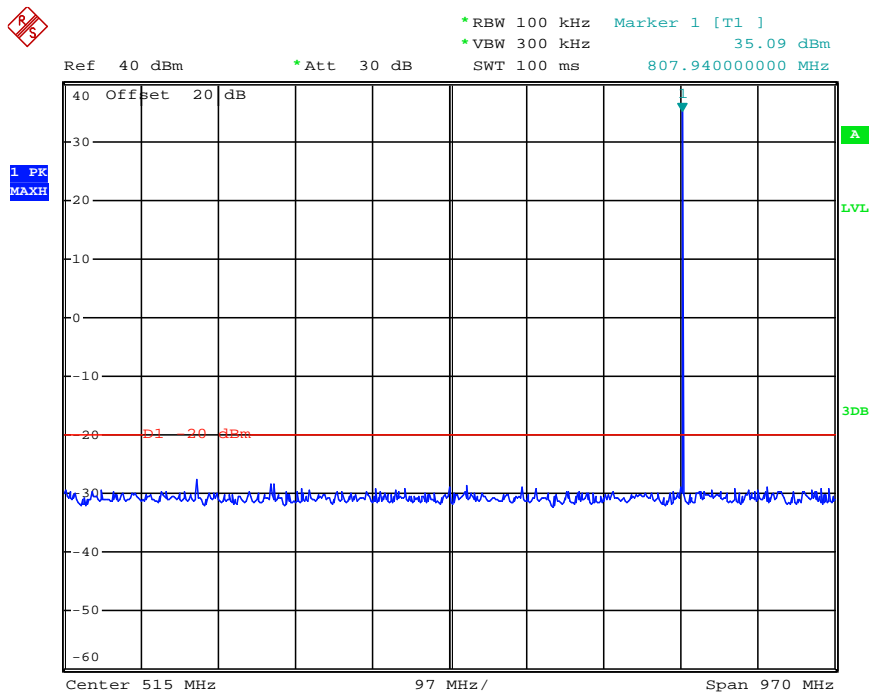

Date: 3.APR.2013 17:30:10

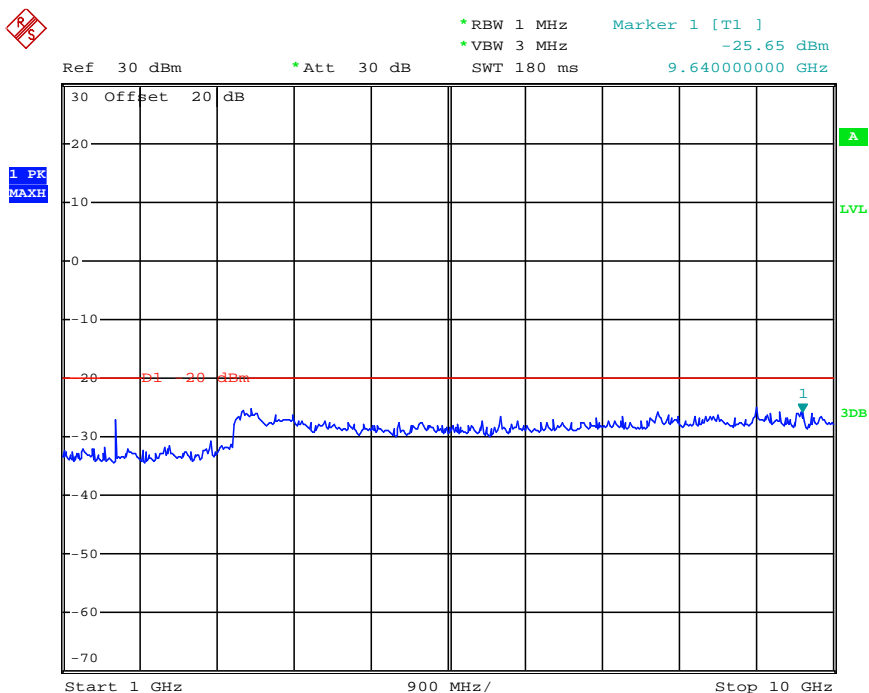

Date: 3.APR.2013 17:36:46

Modulation Type	Channel Sparation	Test Channel	Test Frequency (MHz)	Maximum Conducted Spurious Emissions Below 1GHz		Maximum Conducted Spurious Emissions Above 1GHz		FCC Limit
				Frequency (MHz)	Datum (dBm)	Frequency (MHz)	Datum (dBm)	
4FSK	12.5KHz	Middle	817.0000	873.56	-29.52	7858.00	-25.52	-20dBm
Test Results				Compliance				

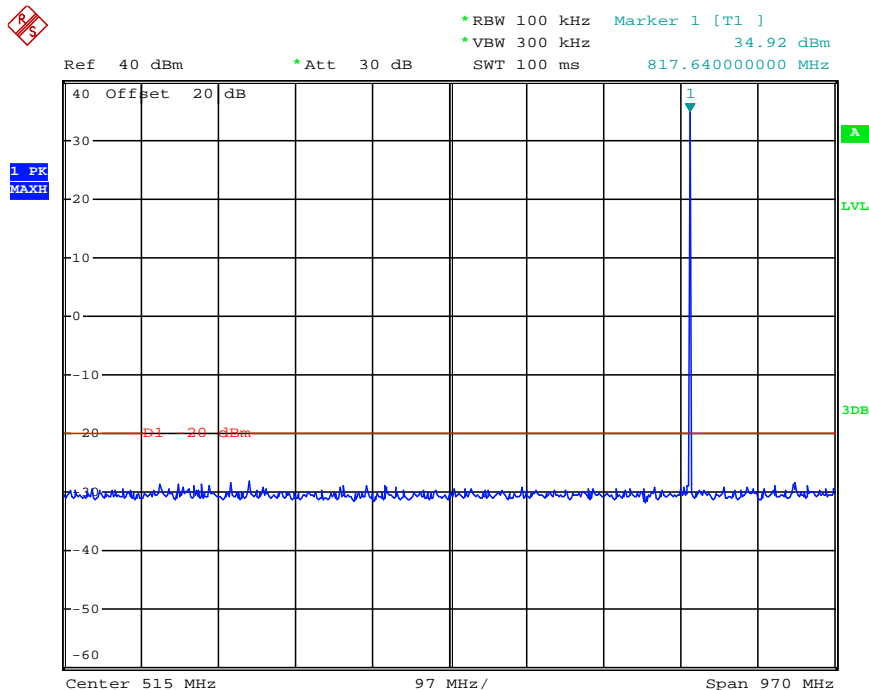

Date: 3.APR.2013 17:29:35

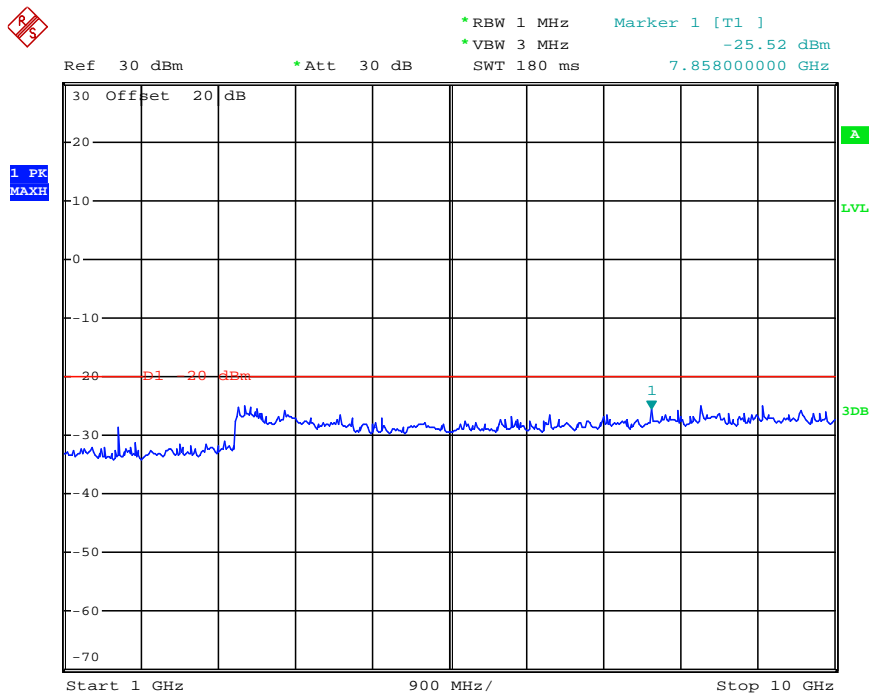

Date: 3.APR.2013 17:37:21

Modulation Type	Channel Separation	Test Channel	Test Frequency (MHz)	Maximum Conducted Spurious Emissions Below 1GHz		Maximum Conducted Spurious Emissions Above 1GHz		FCC Limit
				Frequency (MHz)	Datum (dBm)	Frequency (MHz)	Datum (dBm)	
4FSK	12.5KHz	High	823.5000	873.05	-29.36	3106.00	-25.29	-20dBm
Test Results				Compliance				

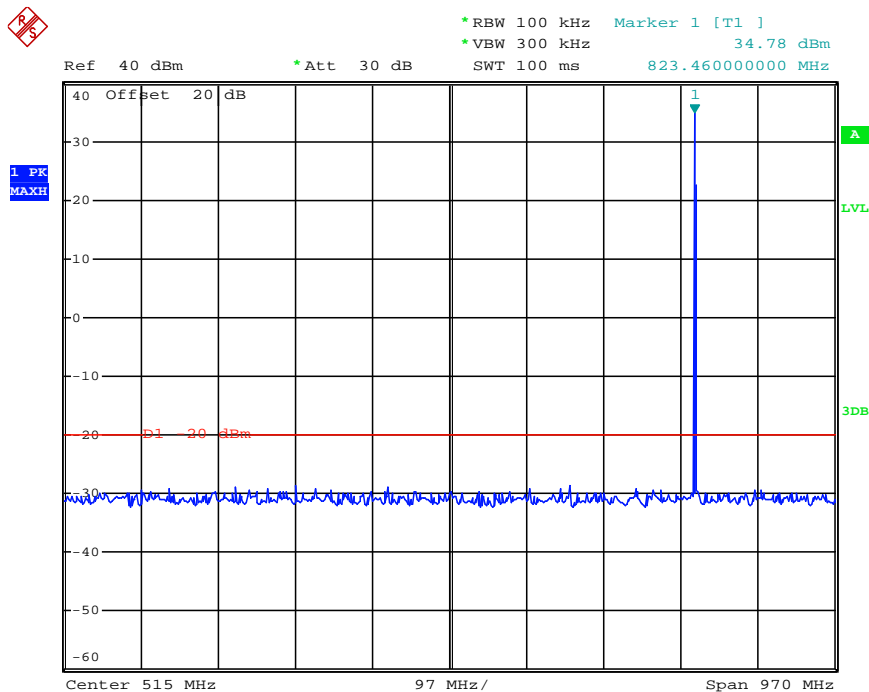

Date: 3.APR.2013 17:30:37

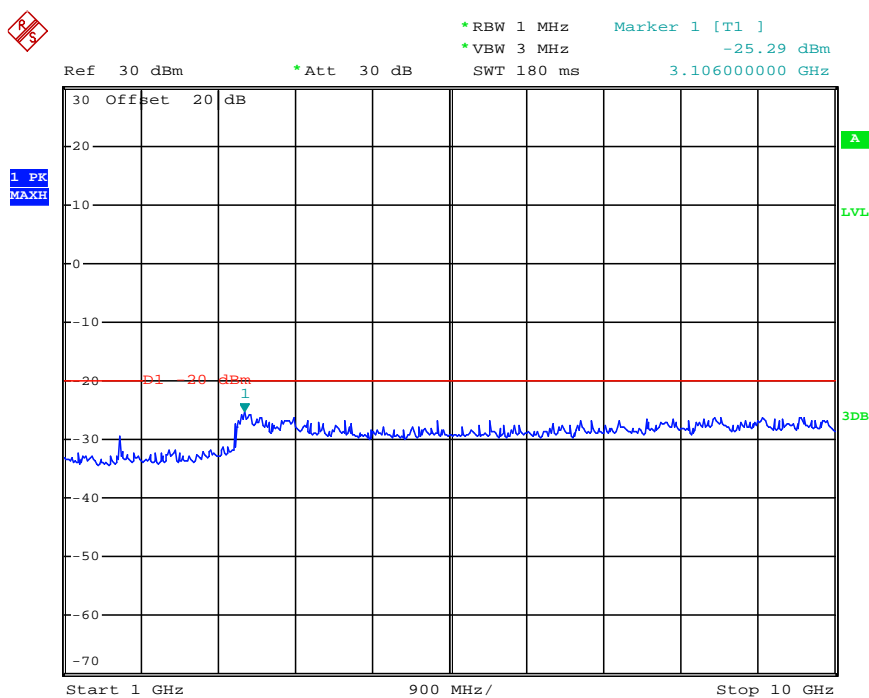

Date: 3.APR.2013 17:37:50

Modulation Type	Channel Sparation	Test Channel	Test Frequency (MHz)	Maximum Conducted Spurious Emissions Below 1GHz		Maximum Conducted Spurious Emissions Above 1GHz		FCC Limit
				Frequency (MHz)	Datum (dBm)	Frequency (MHz)	Datum (dBm)	
4FSK	12.5KHz	Low	851.5000	637.24	-29.52	3106.00	-25.63	-20dBm
Test Results				Compliance				

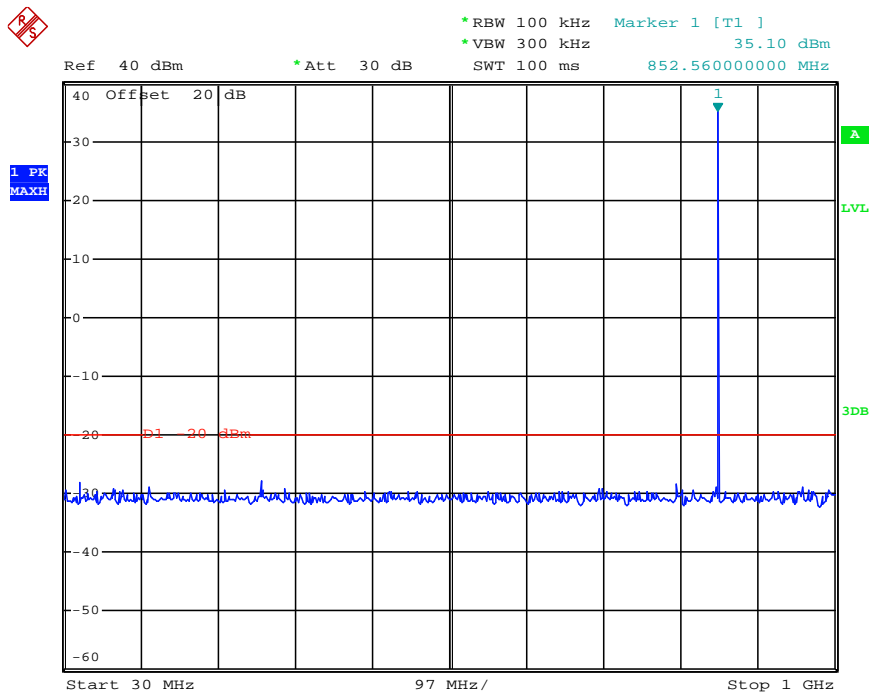

Date: 3.APR.2013 18:01:54

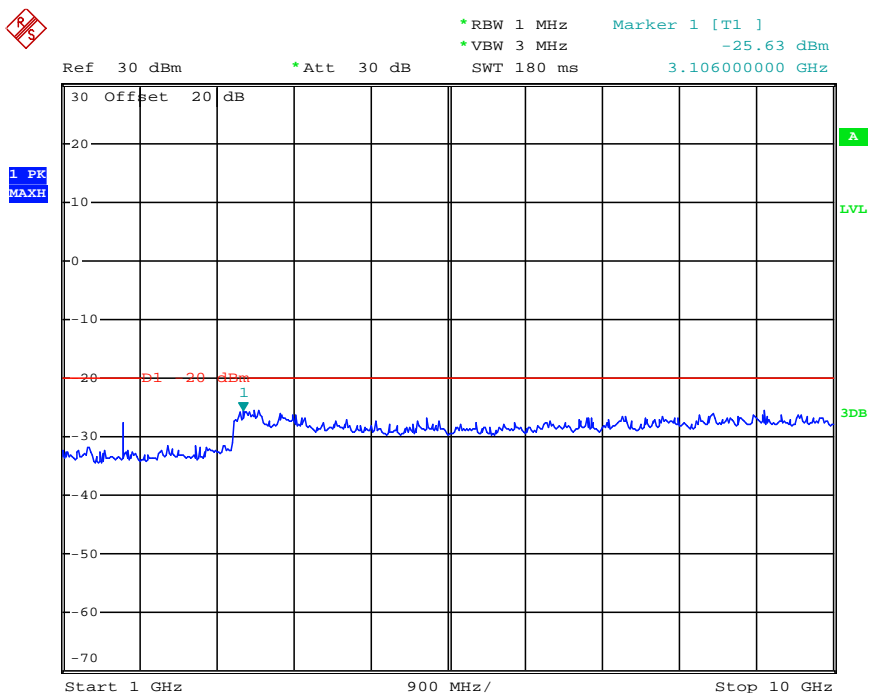

Date: 3.APR.2013 17:52:12

Modulation Type	Channel Sparation	Test Channel	Test Frequency (MHz)	Maximum Conducted Spurious Emissions Below 1GHz		Maximum Conducted Spurious Emissions Above 1GHz		FCC Limit
				Frequency (MHz)	Datum (dBm)	Frequency (MHz)	Datum (dBm)	
4FSK	12.5KHz	Middle	860.0000	973.11	-29.63	3268.00	-26.08	-20dBm
Test Results				Compliance				

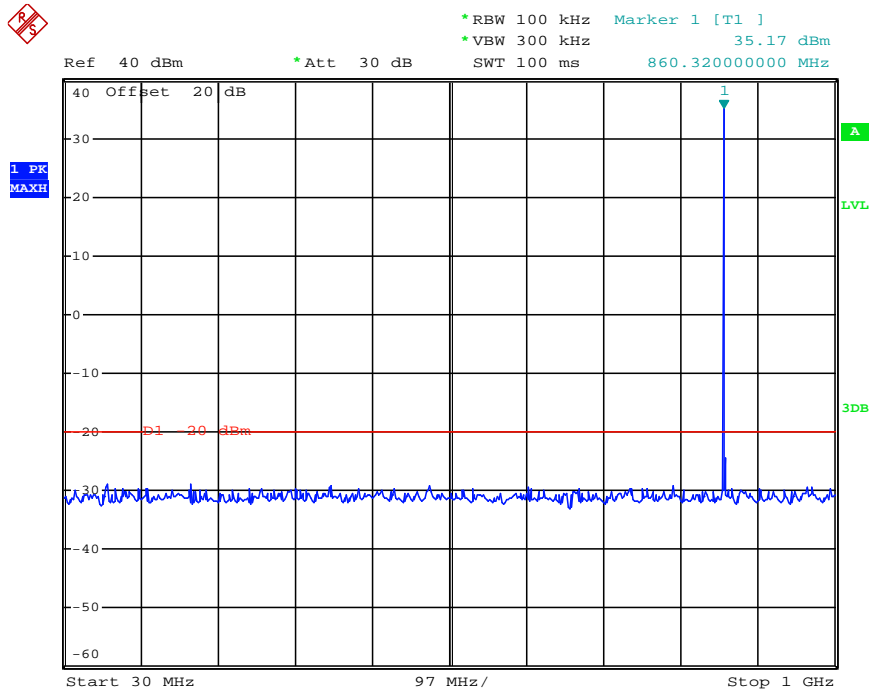

Date: 3.APR.2013 18:02:24

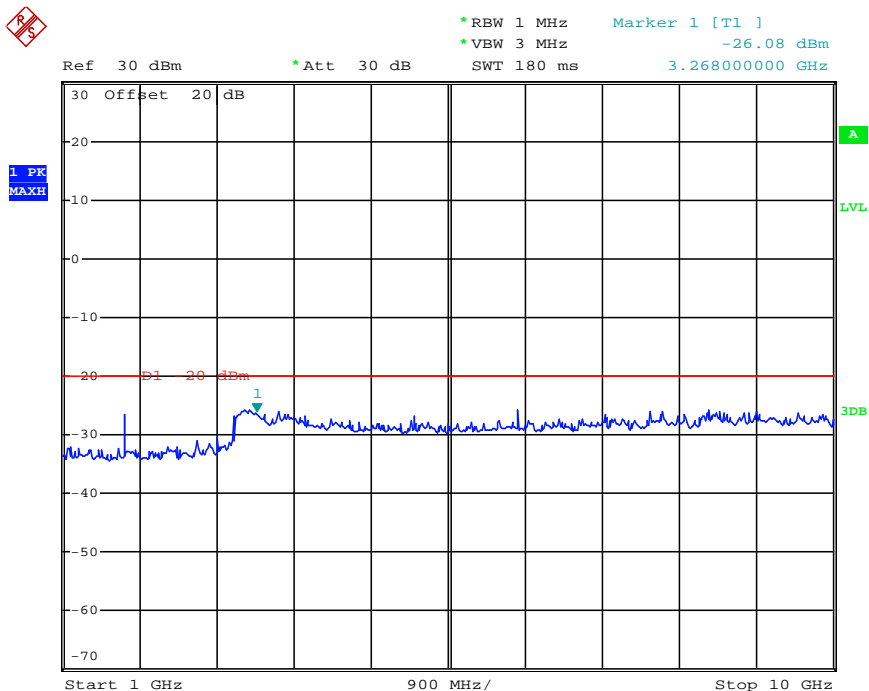

Date: 3.APR.2013 17:52:48

Modulation Type	Channel Sparation	Test Channel	Test Frequency (MHz)	Maximum Conducted Spurious Emissions Below 1GHz		Maximum Conducted Spurious Emissions Above 1GHz		FCC Limit
				Frequency (MHz)	Datum (dBm)	Frequency (MHz)	Datum (dBm)	
4FSK	12.5KHz	High	868.5000	687.20	-28.96	3016.00	-25.08	-20dBm
Test Results				Compliance				

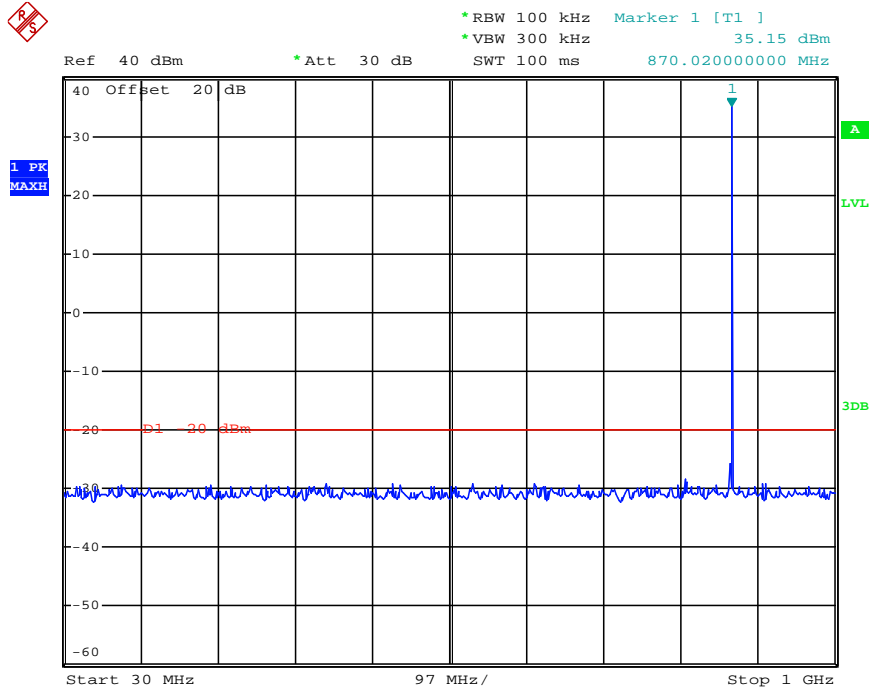

Date: 3.APR.2013 18:03:11

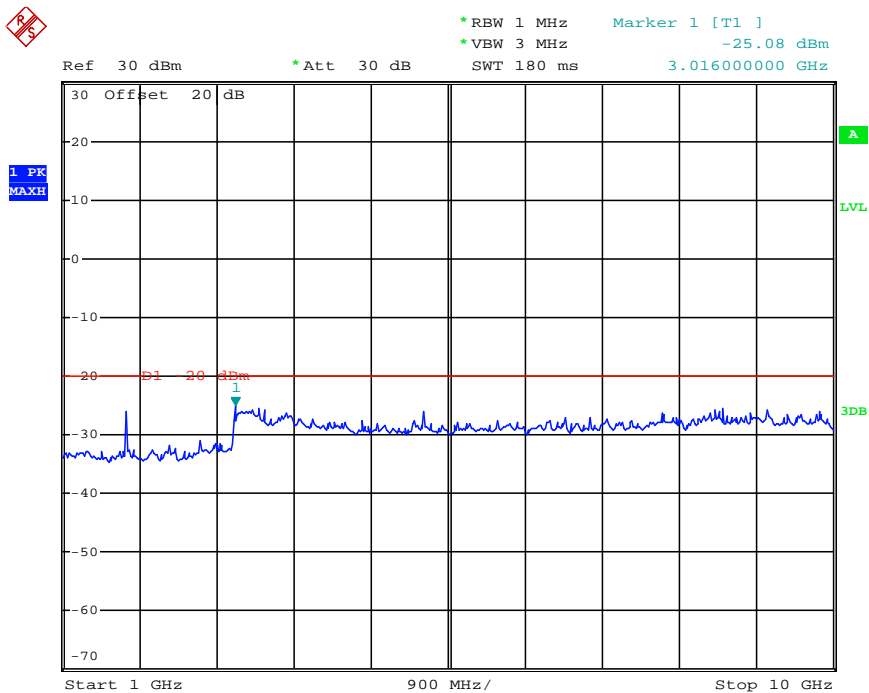

Date: 3.APR.2013 17:53:24

Modulation Type	Channel Sparation	Test Channel	Test Frequency (MHz)	Maximum Conducted Spurious Emissions Below 1GHz		Maximum Conducted Spurious Emissions Above 1GHz		FCC Limit
				Frequency (MHz)	Datum (dBm)	Frequency (MHz)	Datum (dBm)	
4FSK	12.5KHz	Low	896.5000	786.97	-29.63	3052.00	-24.56	-20dBm
Test Results				Compliance				

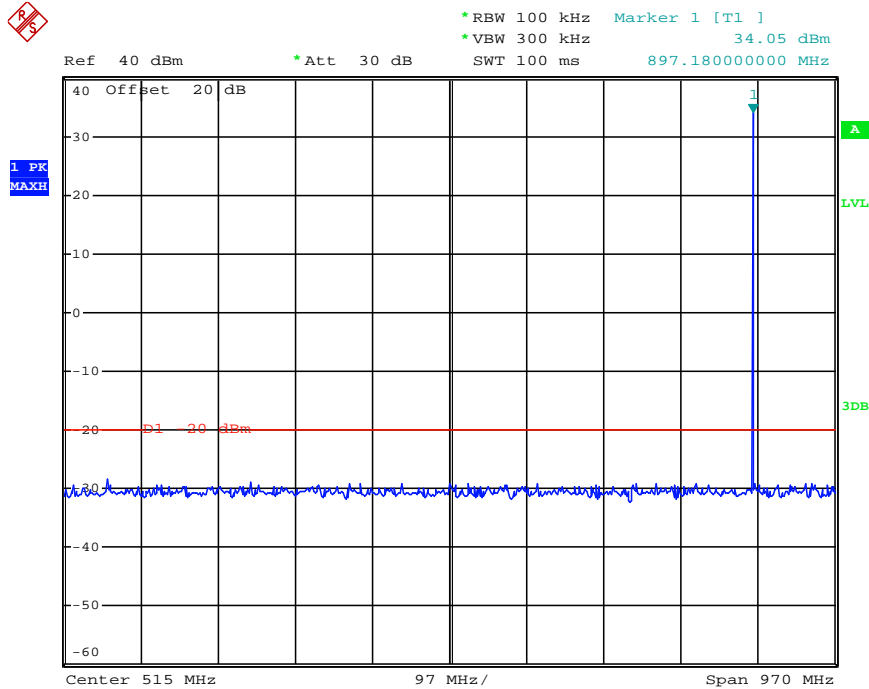

Date: 3.APR.2013 17:31:11

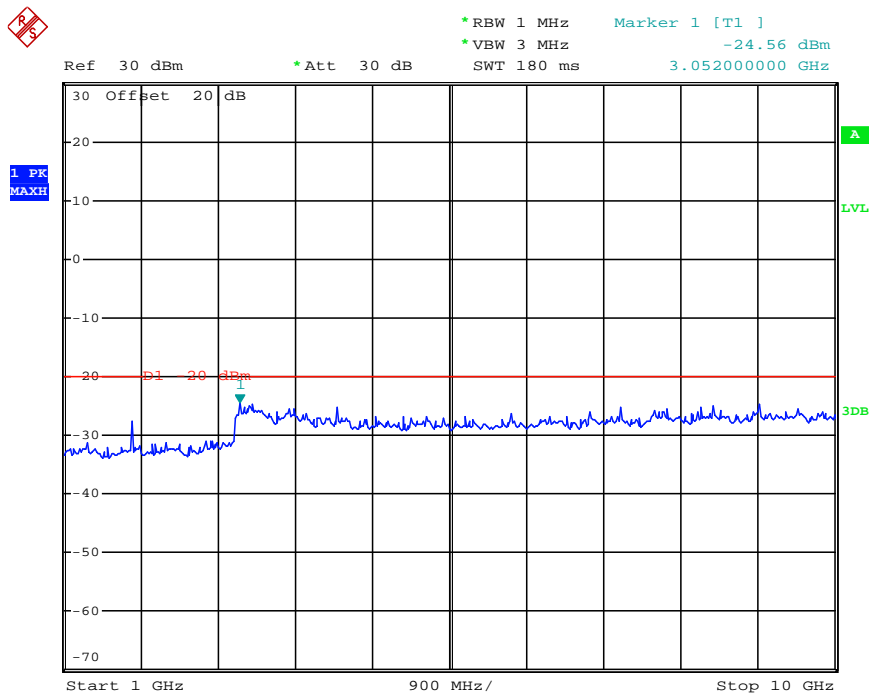

Date: 3.APR.2013 17:38:52

Modulation Type	Channel Sparation	Test Channel	Test Frequency (MHz)	Maximum Conducted Spurious Emissions Below 1GHz		Maximum Conducted Spurious Emissions Above 1GHz		FCC Limit
				Frequency (MHz)	Datum (dBm)	Frequency (MHz)	Datum (dBm)	
4FSK	12.5KHz	High	900.5000	367.21	-29.65	8560.00	-25.53	-20dBm
Test Results				Compliance				

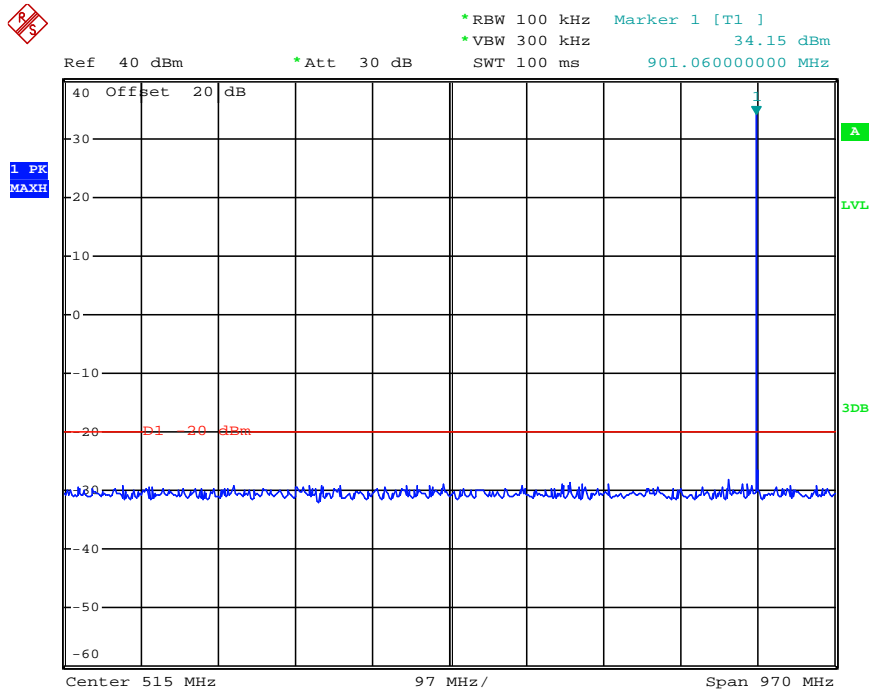

Date: 3.APR.2013 17:31:51

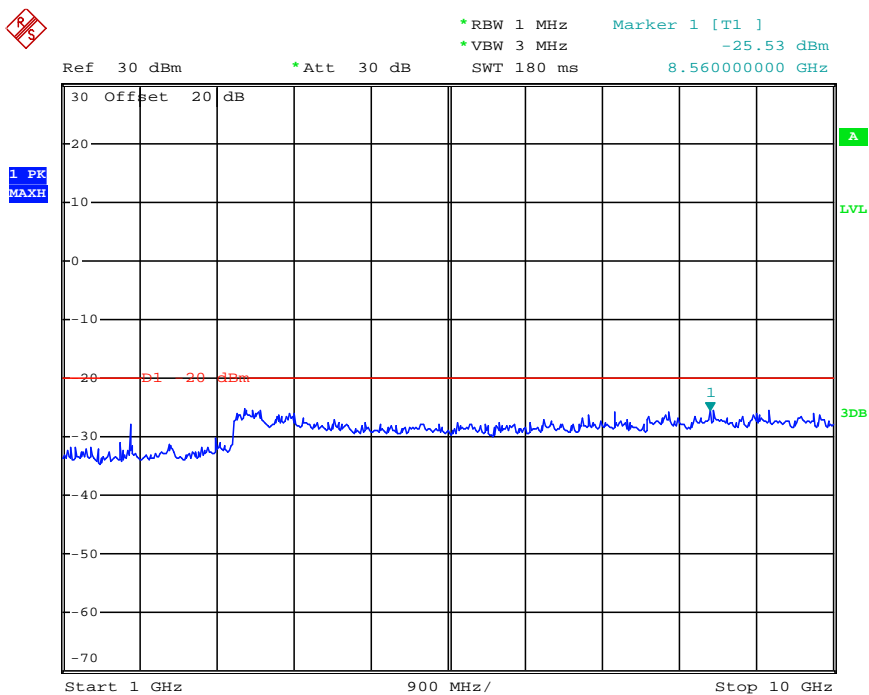

Date: 3.APR.2013 17:39:27

Modulation Type	Channel Sparation	Test Channel	Test Frequency (MHz)	Maximum Conducted Spurious Emissions Below 1GHz		Maximum Conducted Spurious Emissions Above 1GHz		FCC Limit
				Frequency (MHz)	Datum (dBm)	Frequency (MHz)	Datum (dBm)	
4FSK	12.5KHz	Low	935.5000	973.21	-29.85	3124.00	-25.83	-20dBm
Test Results				Compliance				

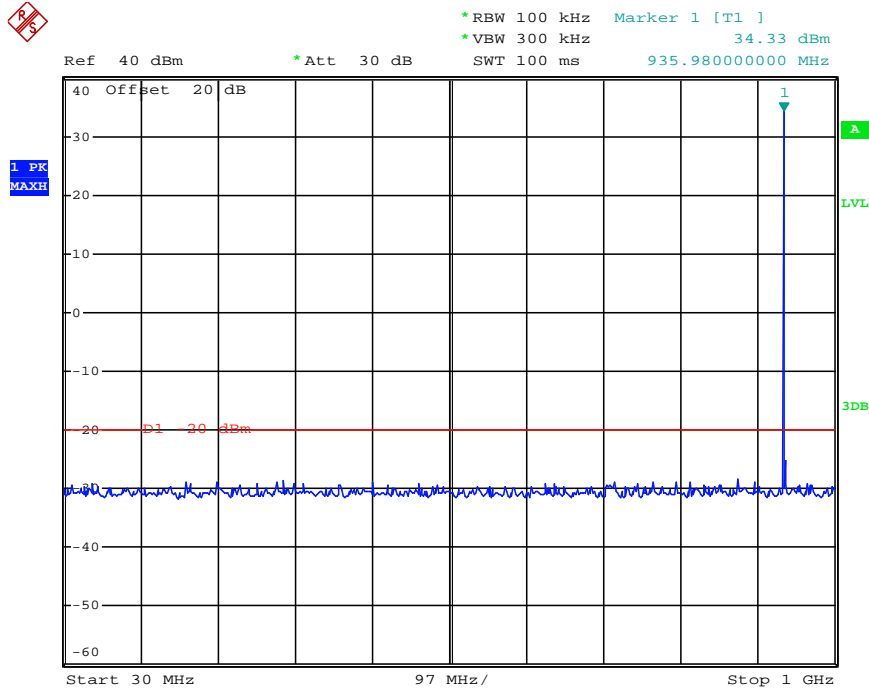

Date: 3.APR.2013 18:03:44

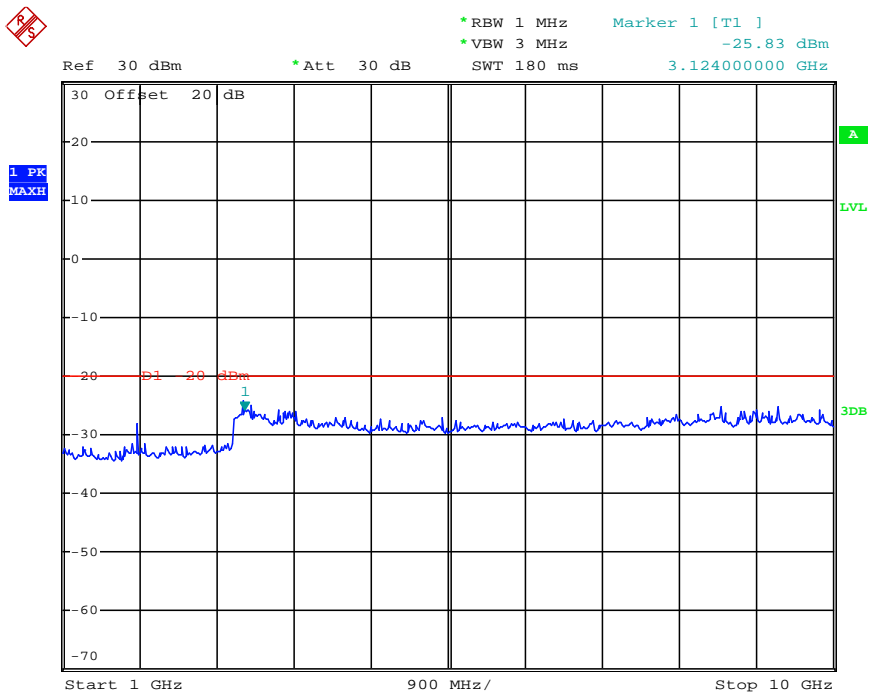

Date: 3.APR.2013 17:53:57

Modulation Type	Channel Sparation	Test Channel	Test Frequency (MHz)	Maximum Conducted Spurious Emissions Below 1GHz		Maximum Conducted Spurious Emissions Above 1GHz		FCC Limit
				Frequency (MHz)	Datum (dBm)	Frequency (MHz)	Datum (dBm)	
4FSK	12.5KHz	High	939.5000	680.21	-29.06	3160.00	-25.59	-20dBm
Test Results				Compliance				

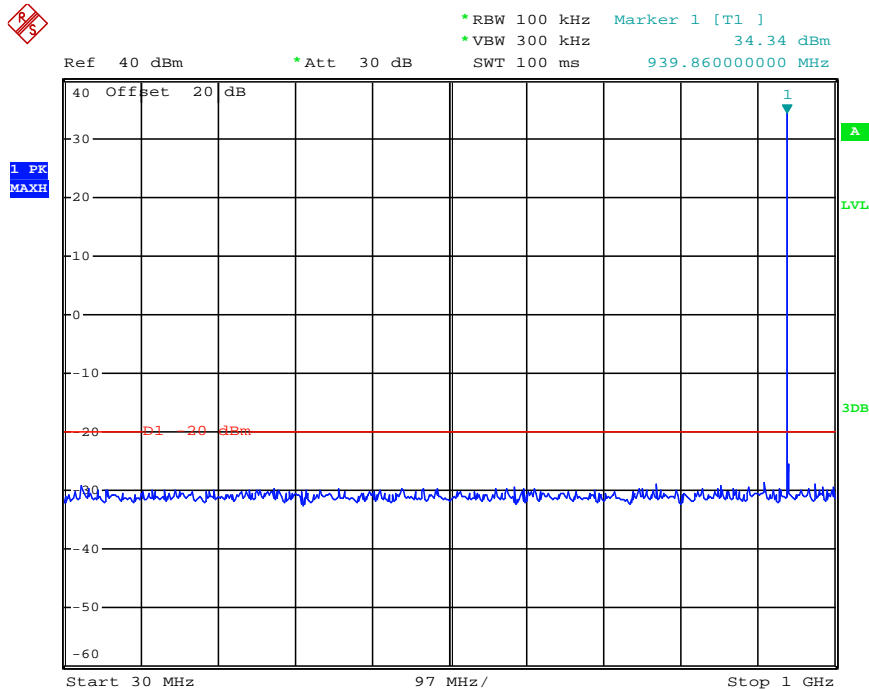

Date: 3.APR.2013 18:04:11

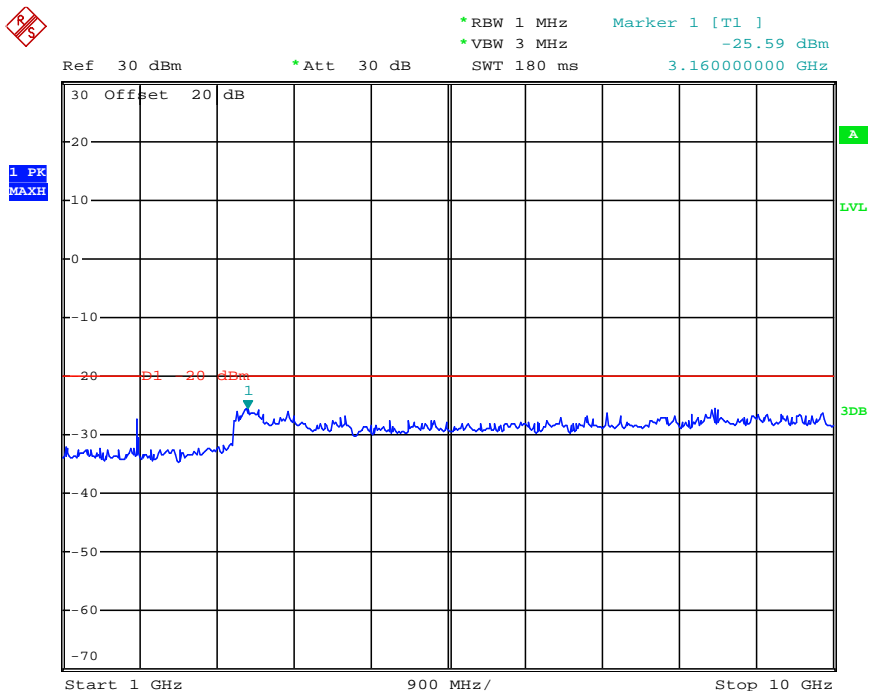

Date: 3.APR.2013 17:54:23

For Rated Low Power (1Watt)

Modulation Type	Channel Sparation	Test Channel	Test Frequency (MHz)	Maximum Conducted Spurious Emissions Below 1GHz		Maximum Conducted Spurious Emissions Above 1GHz		FCC Limit
				Frequency (MHz)	Datum (dBm)	Frequency (MHz)	Datum (dBm)	
FM	25KHz	Low	806.5000	687.33	-29.78	3106.00	-24.90	-13dBm
Test Results				Compliance				

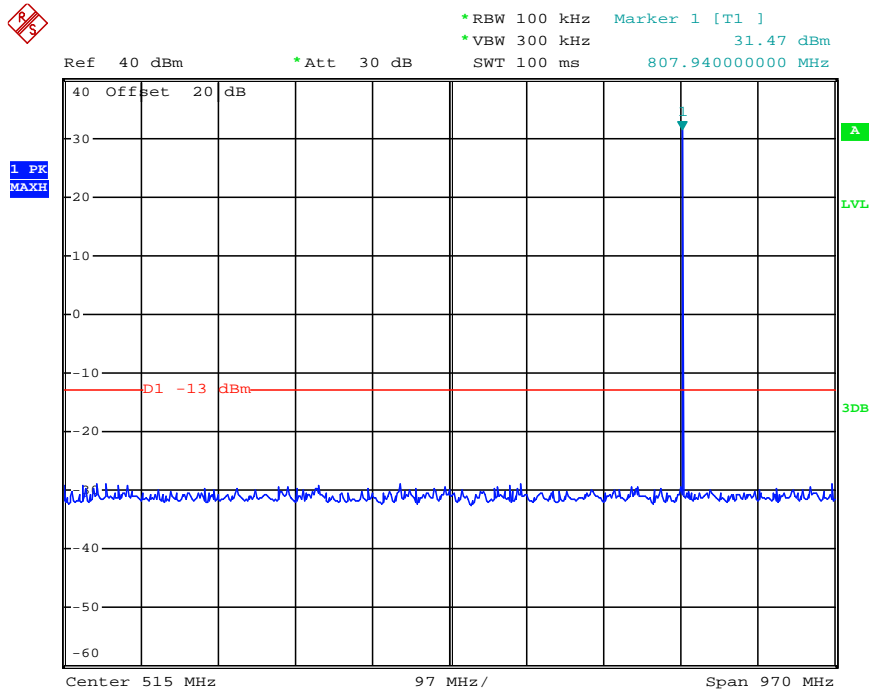

Date: 3.APR.2013 17:26:31

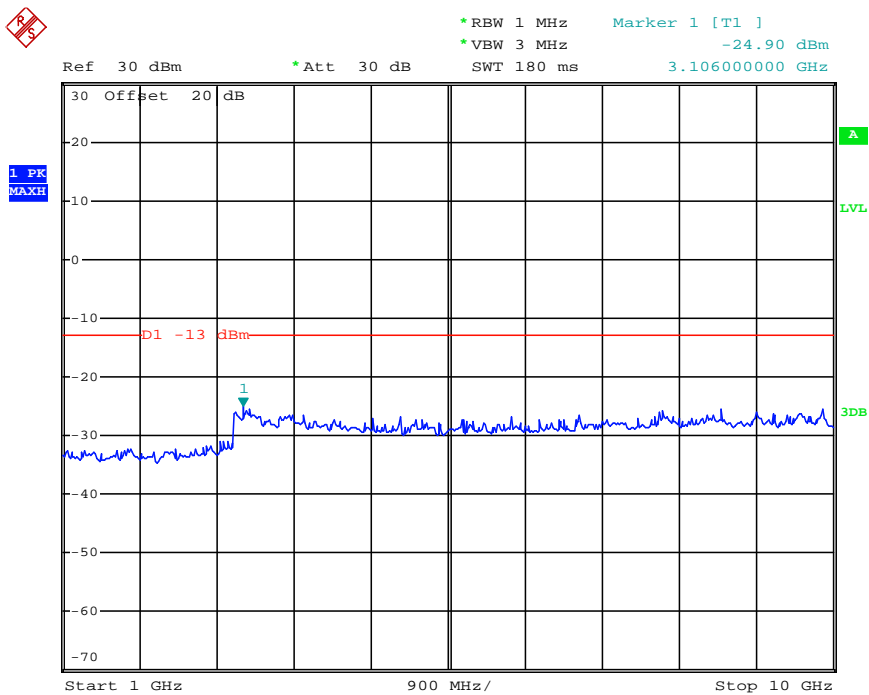

Date: 3.APR.2013 17:40:45

Modulation Type	Channel Sparation	Test Channel	Test Frequency (MHz)	Maximum Conducted Spurious Emissions Below 1GHz		Maximum Conducted Spurious Emissions Above 1GHz		FCC Limit
				Frequency (MHz)	Datum (dBm)	Frequency (MHz)	Datum (dBm)	
FM	25KHz	Middle	817.0000	869.79	-29.56	3178.00	-25.35	-13dBm
Test Results				Compliance				

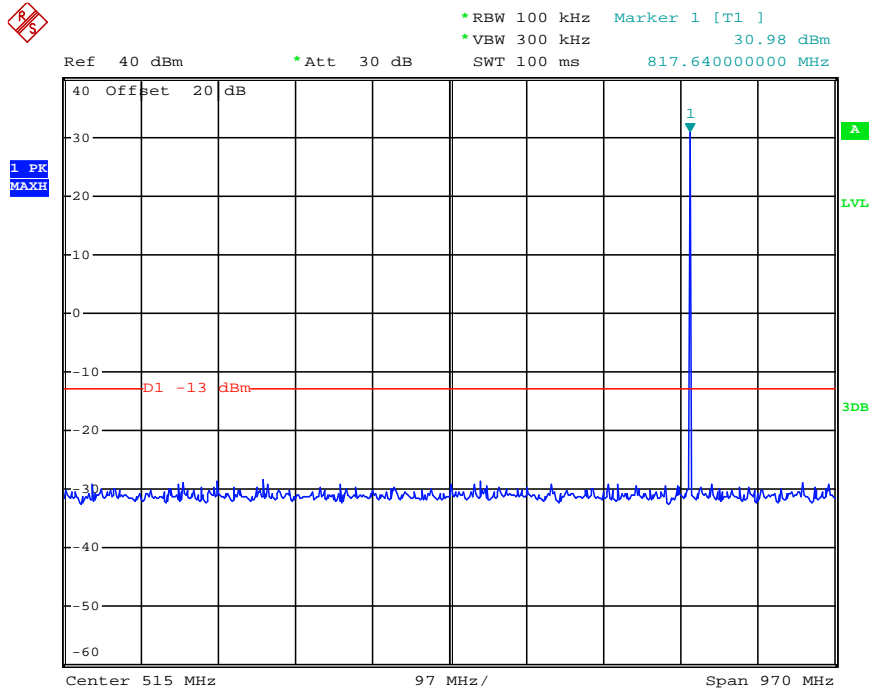

Date: 3.APR.2013 17:26:58

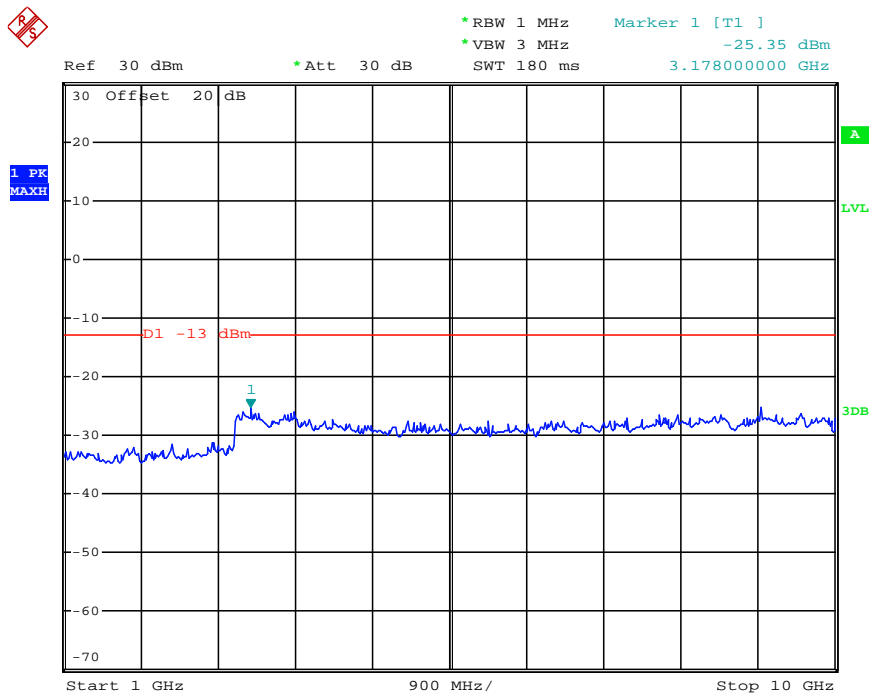

Date: 3.APR.2013 17:40:32

Modulation Type	Channel Sparation	Test Channel	Test Frequency (MHz)	Maximum Conducted Spurious Emissions Below 1GHz		Maximum Conducted Spurious Emissions Above 1GHz		FCC Limit
				Frequency (MHz)	Datum (dBm)	Frequency (MHz)	Datum (dBm)	
FM	25KHz	High	823.5000	753.21	-28.95	8596.00	-25.65	-13dBm
Test Results				Compliance				

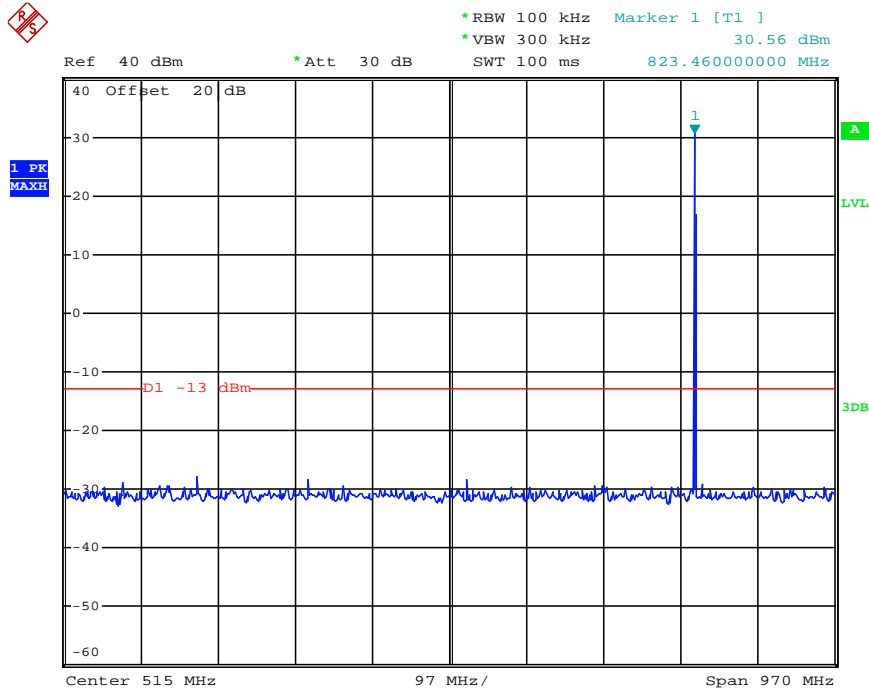

Date: 3.APR.2013 17:27:32

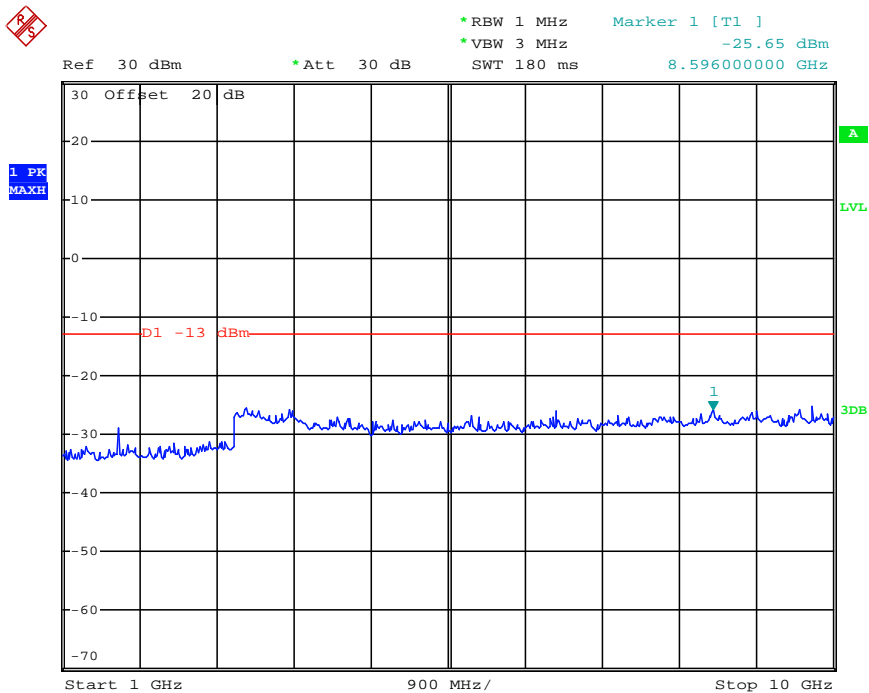

Date: 3.APR.2013 17:41:02

Modulation Type	Channel Sparation	Test Channel	Test Frequency (MHz)	Maximum Conducted Spurious Emissions Below 1GHz		Maximum Conducted Spurious Emissions Above 1GHz		FCC Limit
				Frequency (MHz)	Datum (dBm)	Frequency (MHz)	Datum (dBm)	
FM	25KHz	Low	851.5000	932.10	-28.83	3142.00	-25.26	-13dBm
Test Results				Compliance				

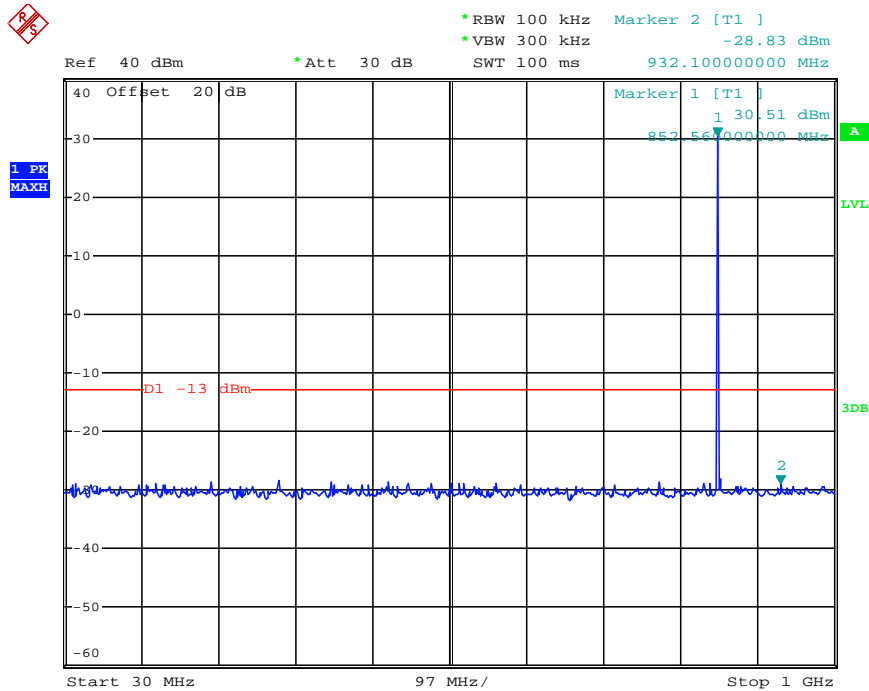

Date: 10.APR.2013 16:46:59

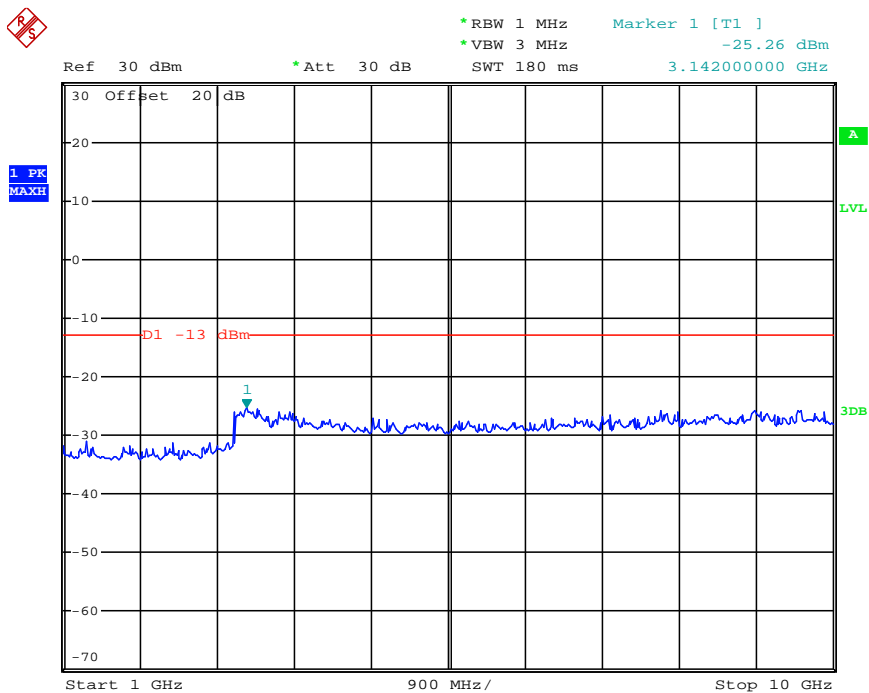

Date: 3.APR.2013 17:42:30

Modulation Type	Channel Sparation	Test Channel	Test Frequency (MHz)	Maximum Conducted Spurious Emissions Below 1GHz		Maximum Conducted Spurious Emissions Above 1GHz		FCC Limit
				Frequency (MHz)	Datum (dBm)	Frequency (MHz)	Datum (dBm)	
FM	25KHz	Middle	860.0000	910.76	-29.88	9928.00	-26.23	-13dBm
Test Results				Compliance				

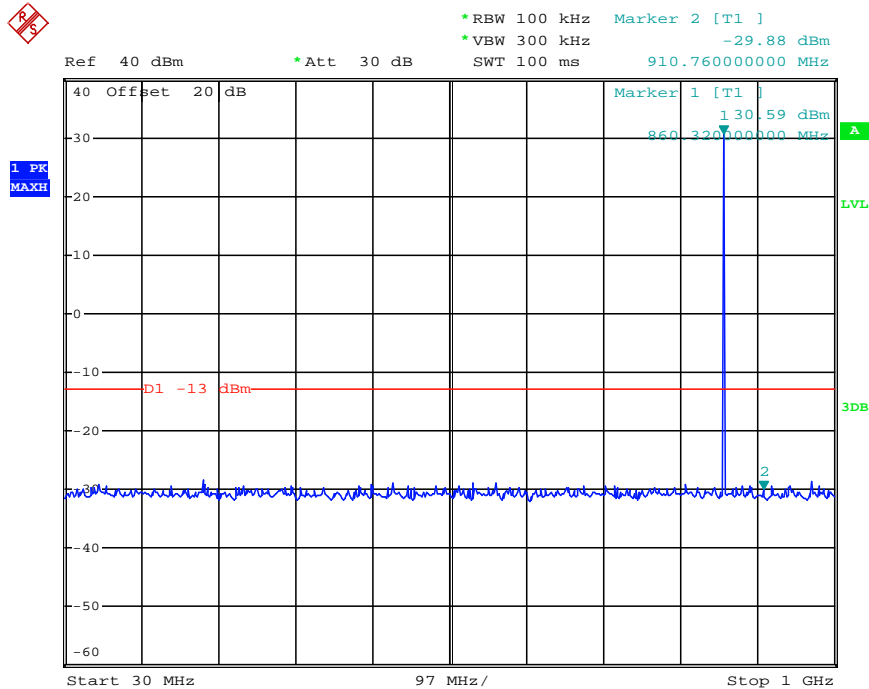

Date: 10.APR.2013 16:47:57

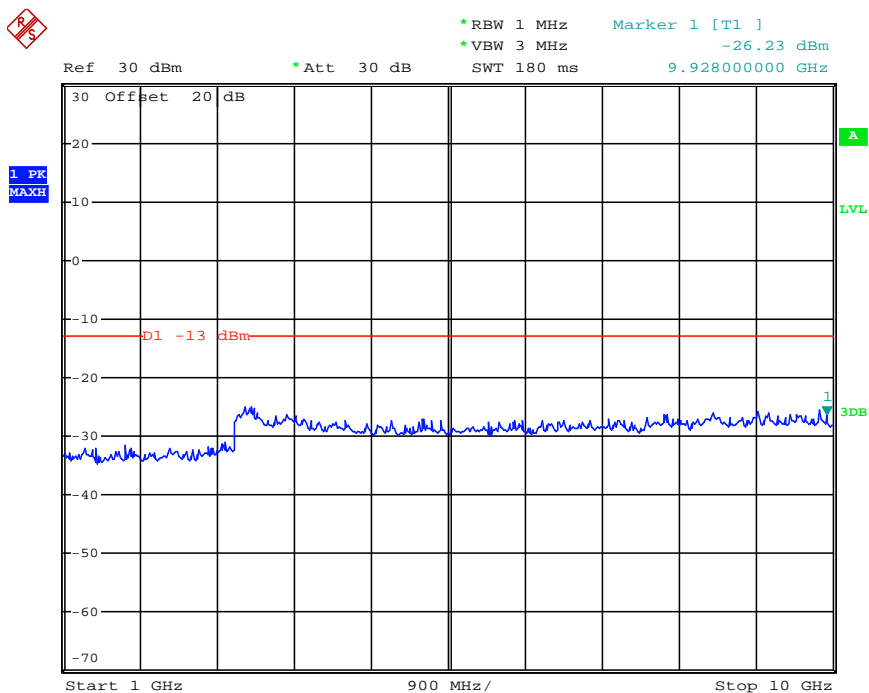

Date: 3.APR.2013 17:43:08

Modulation Type	Channel Sparation	Test Channel	Test Frequency (MHz)	Maximum Conducted Spurious Emissions Below 1GHz		Maximum Conducted Spurious Emissions Above 1GHz		FCC Limit
				Frequency (MHz)	Datum (dBm)	Frequency (MHz)	Datum (dBm)	
FM	25KHz	High	868.5000	986.42	-28.28	3178.00	-26.05	-13dBm
Test Results				Compliance				

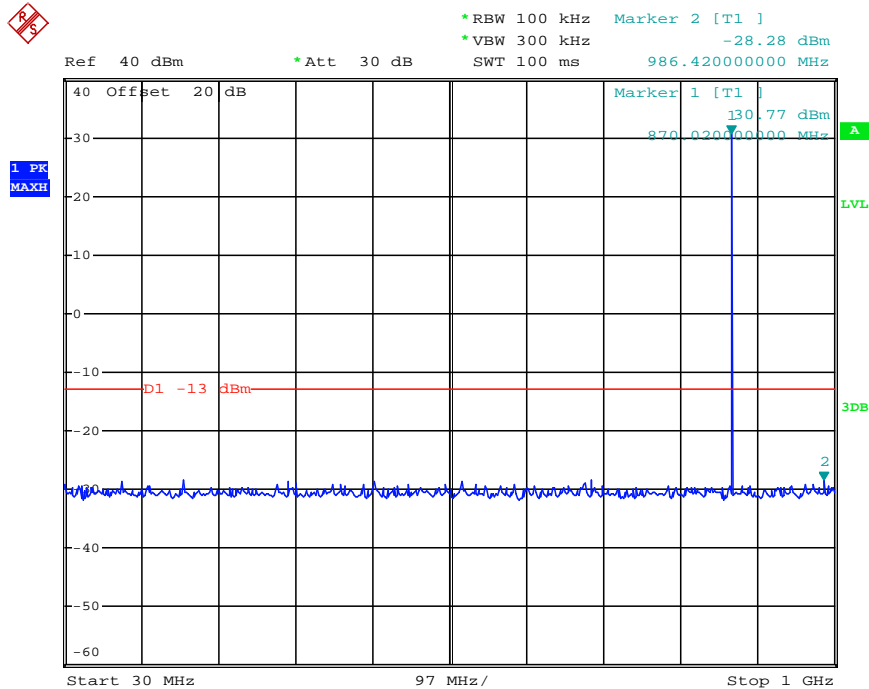

Date: 10.APR.2013 16:48:36

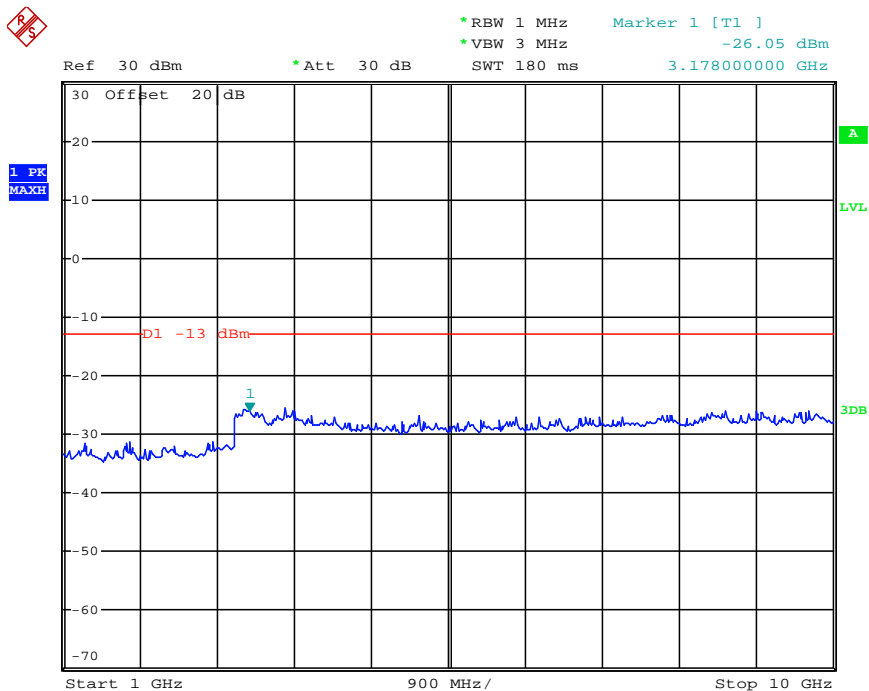

Date: 3.APR.2013 17:46:08

Modulation Type	Channel Sparation	Test Channel	Test Frequency (MHz)	Maximum Conducted Spurious Emissions Below 1GHz		Maximum Conducted Spurious Emissions Above 1GHz		FCC Limit
				Frequency (MHz)	Datum (dBm)	Frequency (MHz)	Datum (dBm)	
FM	12.5KHz	Low	806.5000	690.25	-28.96	3178.00	-25.46	-20dBm
Test Results				Compliance				

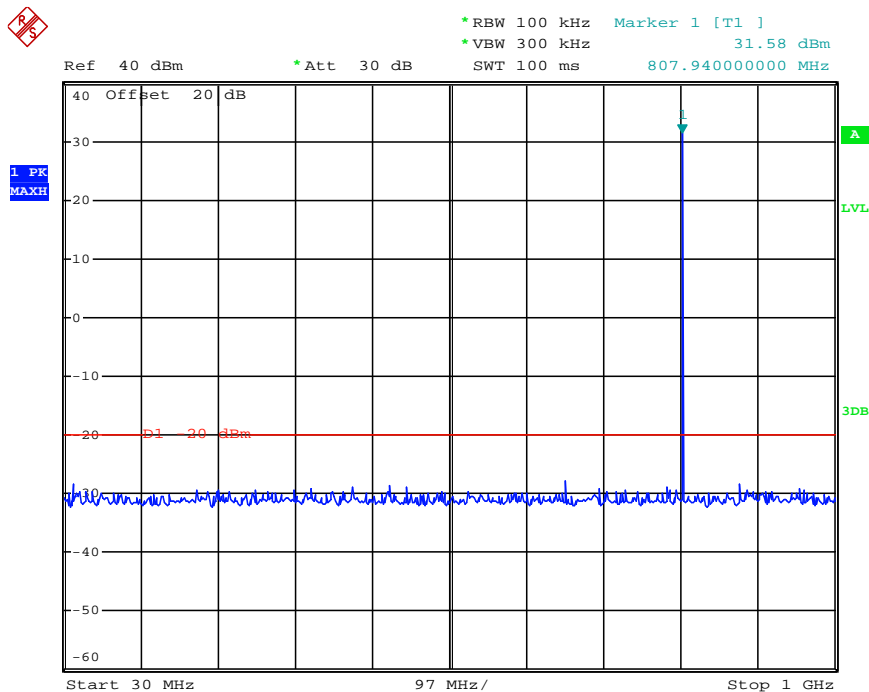

Date: 3.APR.2013 17:23:04

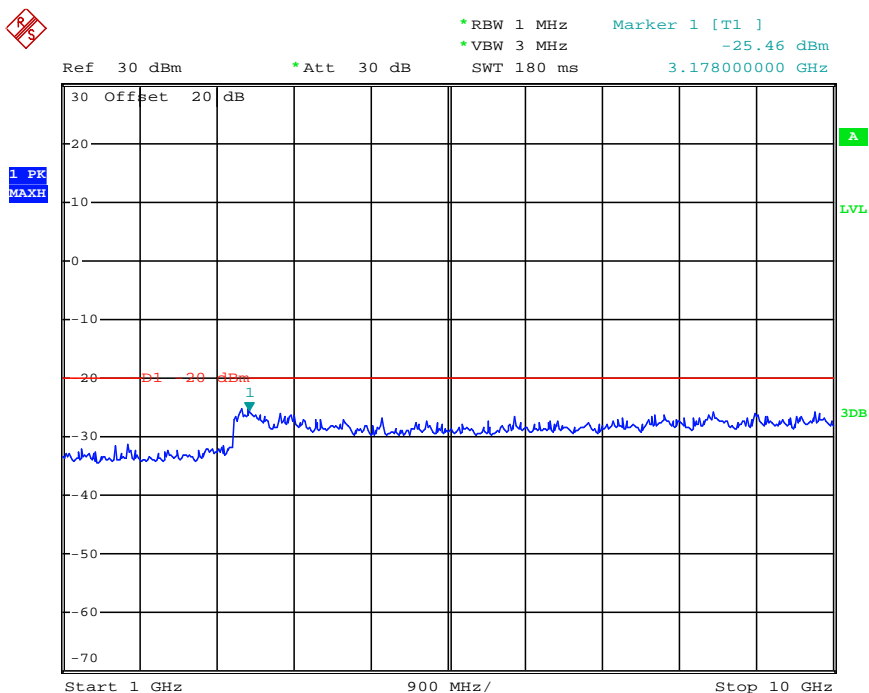

Date: 3.APR.2013 17:33:58

Modulation Type	Channel SpARATION	Test Channel	Test Frequency (MHz)	Maximum Conducted Spurious Emissions Below 1GHz		Maximum Conducted Spurious Emissions Above 1GHz		FCC Limit
				Frequency (MHz)	Datum (dBm)	Frequency (MHz)	Datum (dBm)	
FM	12.5KHz	Middle	817.0000	693.47	-28.56	3142.00	-25.82	-20dBm
Test Results				Compliance				

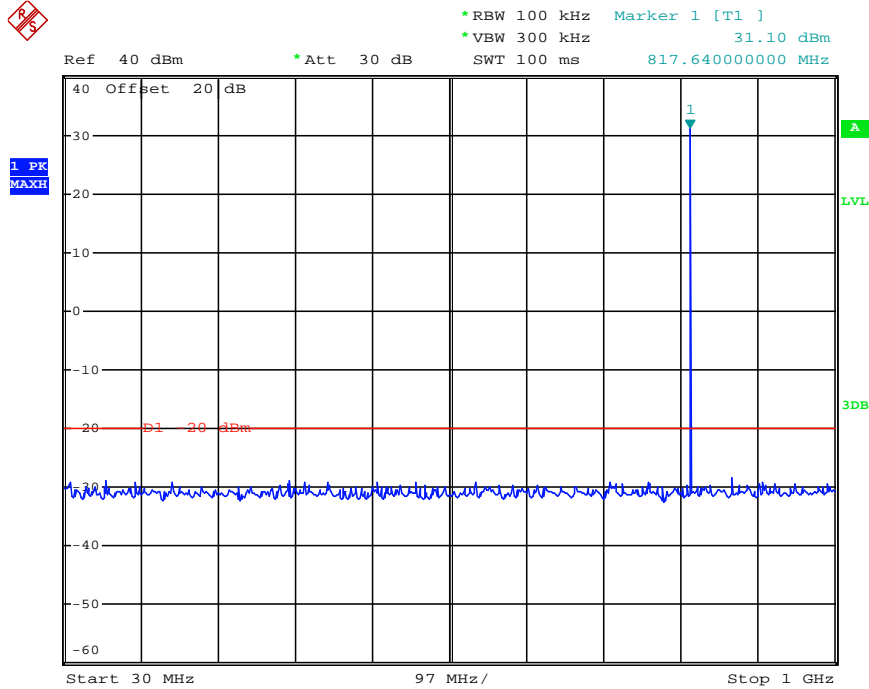

Date: 3.APR.2013 17:23:39

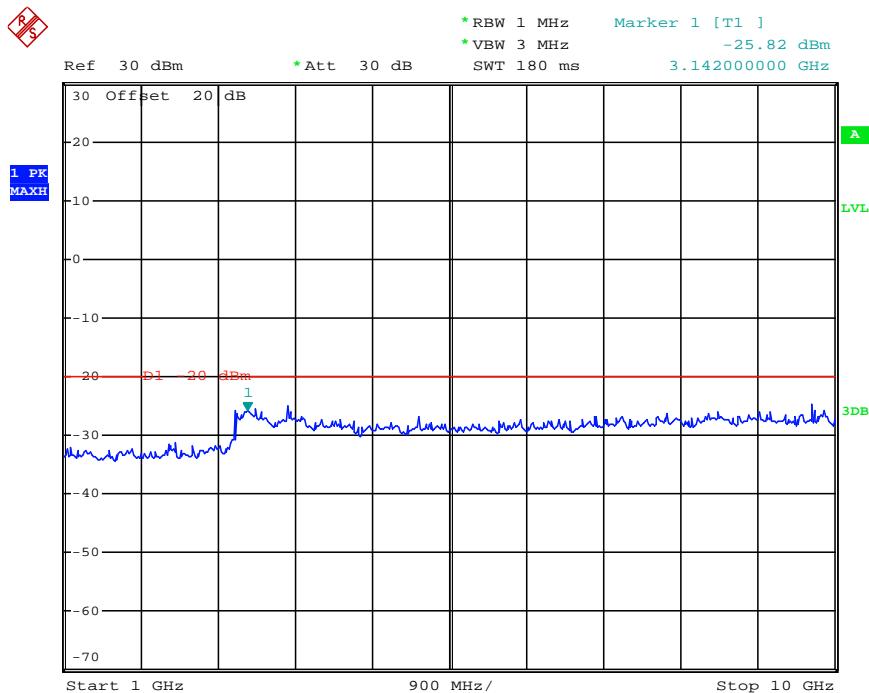

Date: 3.APR.2013 17:34:46

Modulation Type	Channel SpARATION	Test Channel	Test Frequency (MHz)	Maximum Conducted Spurious Emissions Below 1GHz		Maximum Conducted Spurious Emissions Above 1GHz		FCC Limit
				Frequency (MHz)	Datum (dBm)	Frequency (MHz)	Datum (dBm)	
FM	12.5KHz	High	823.5000	693.52	-29.24	9262.00	25.74	-20dBm
Test Results				Compliance				

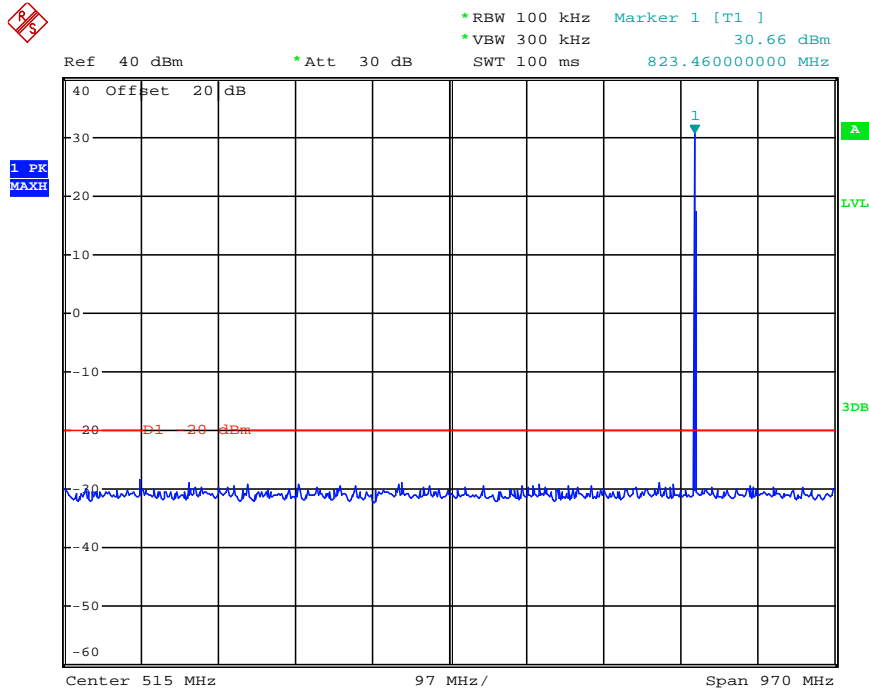

Date: 3.APR.2013 17:24:17

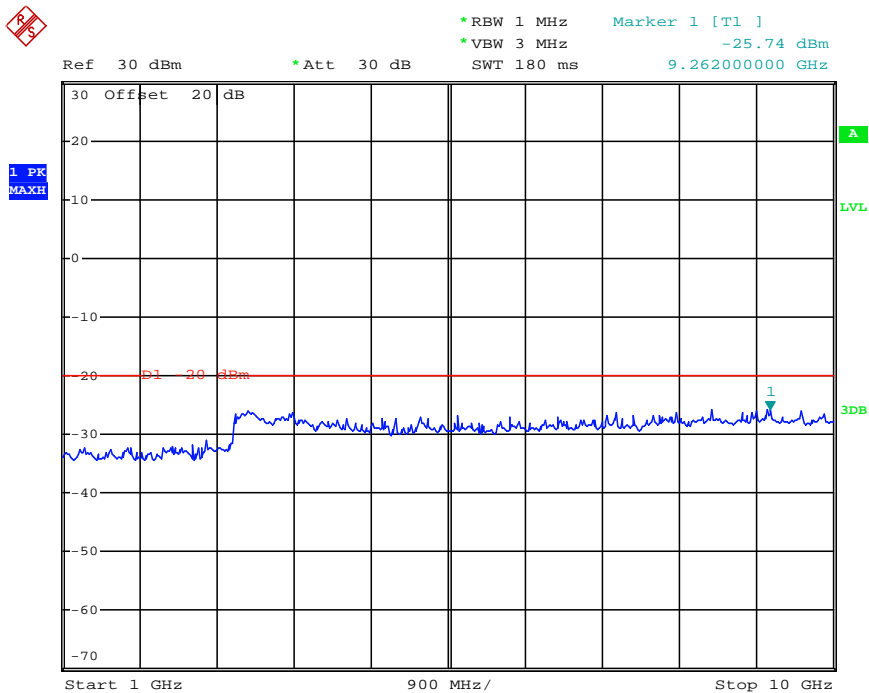

Date: 3.APR.2013 17:35:19

Modulation Type	Channel Sparation	Test Channel	Test Frequency (MHz)	Maximum Conducted Spurious Emissions Below 1GHz		Maximum Conducted Spurious Emissions Above 1GHz		FCC Limit
				Frequency (MHz)	Datum (dBm)	Frequency (MHz)	Datum (dBm)	
FM	12.5KHz	Low	851.5000	683.21	-29.14	3178.00	-25.53	-20dBm
Test Results				Compliance				

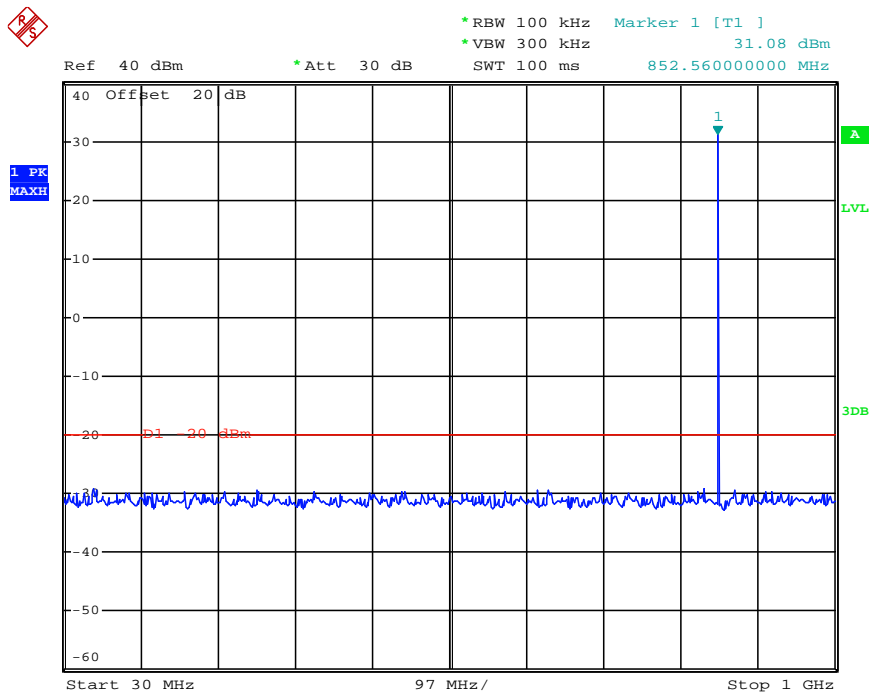

Date: 3.APR.2013 17:58:11

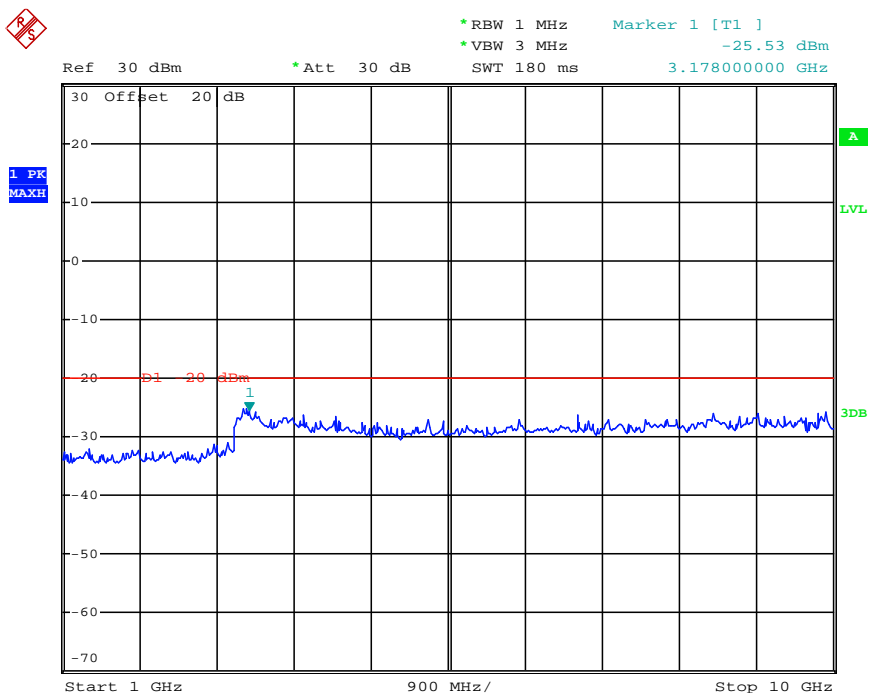

Date: 3.APR.2013 17:49:53

Modulation Type	Channel Sparation	Test Channel	Test Frequency (MHz)	Maximum Conducted Spurious Emissions Below 1GHz		Maximum Conducted Spurious Emissions Above 1GHz		FCC Limit
				Frequency (MHz)	Datum (dBm)	Frequency (MHz)	Datum (dBm)	
FM	12.5KHz	Middle	860.0000	795.21	-29.45	3286.00	-26.50	-20dBm
Test Results				Compliance				

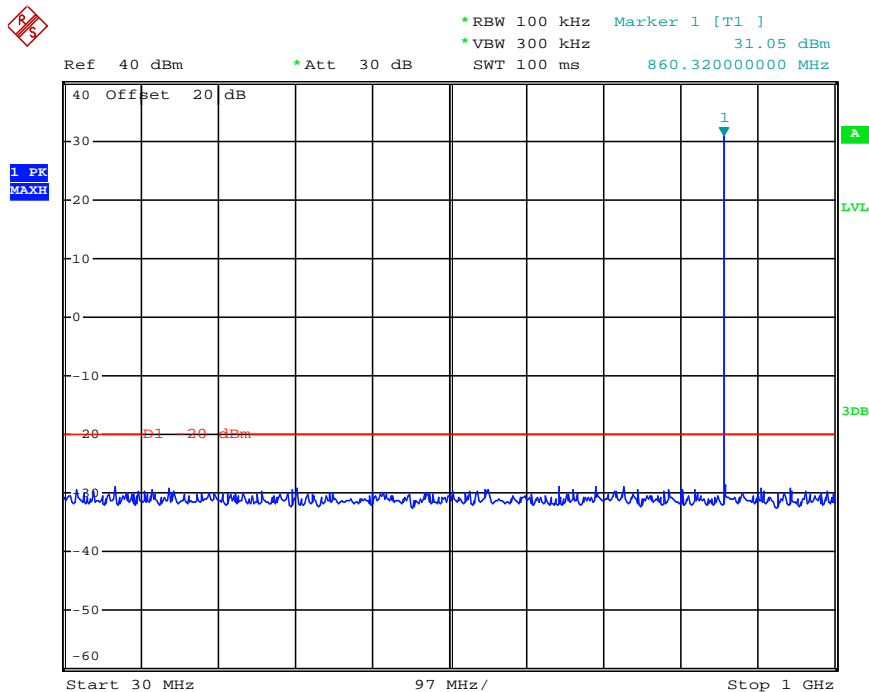

Date: 3.APR.2013 17:59:02

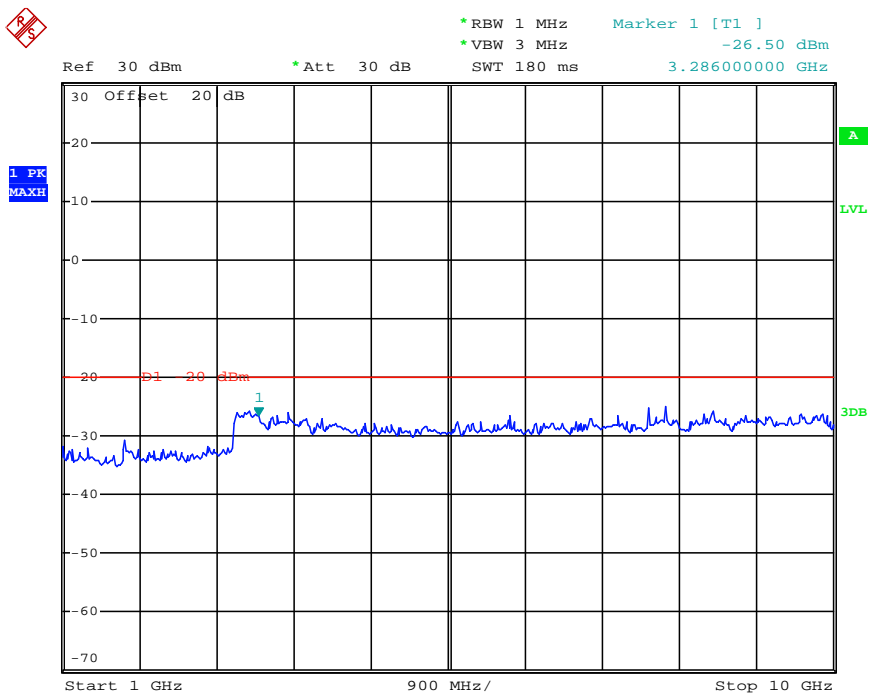

Date: 3.APR.2013 17:50:18

Modulation Type	Channel Sparation	Test Channel	Test Frequency (MHz)	Maximum Conducted Spurious Emissions Below 1GHz		Maximum Conducted Spurious Emissions Above 1GHz		FCC Limit
				Frequency (MHz)	Datum (dBm)	Frequency (MHz)	Datum (dBm)	
FM	12.5KHz	High	868.5000	963.22	-29.54	9082.00	-25.74	-20dBm
Test Results				Compliance				

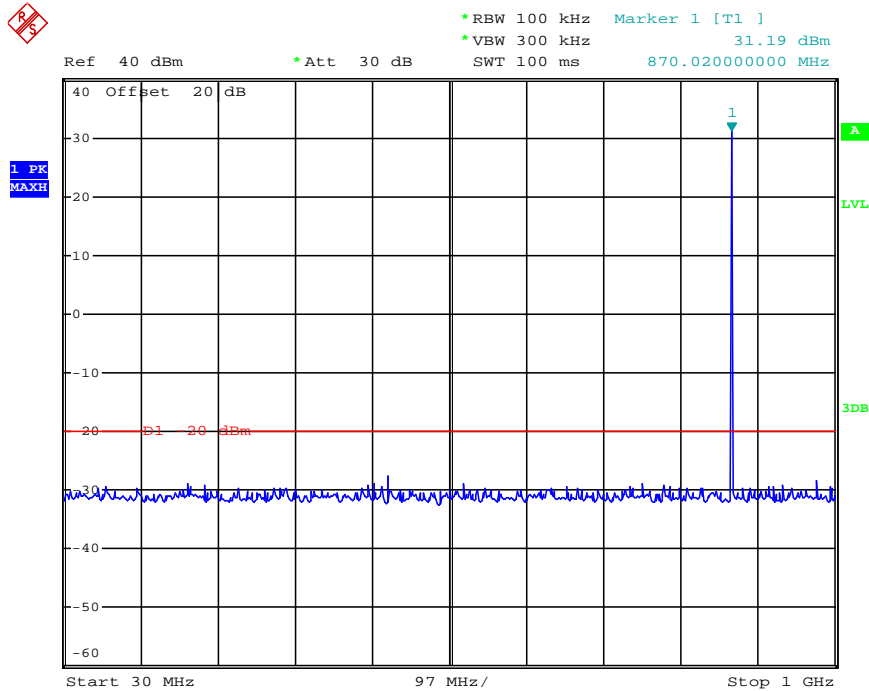

Date: 3.APR.2013 18:00:23

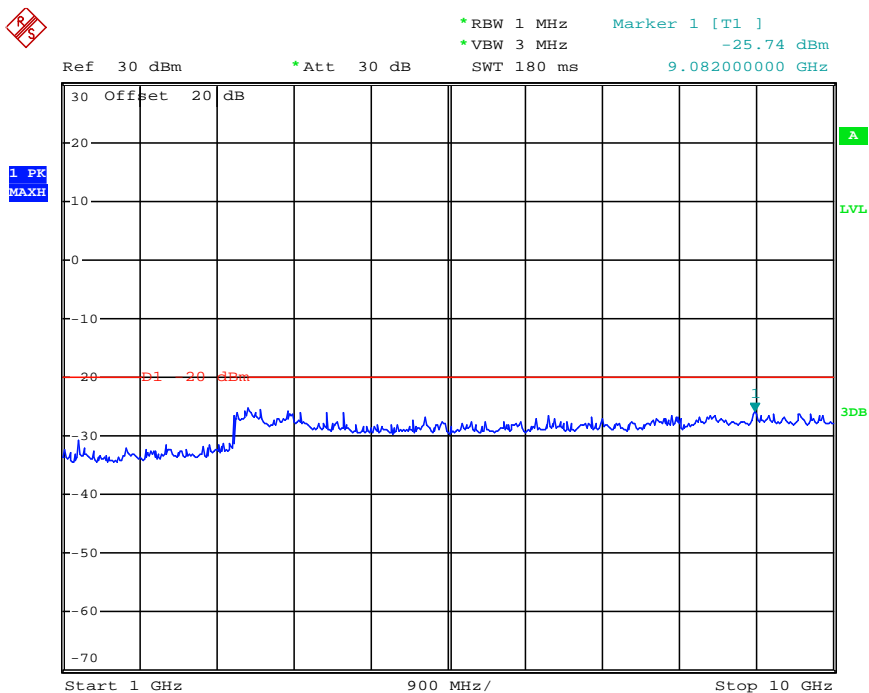

Date: 3.APR.2013 17:50:50

Modulation Type	Channel Sparation	Test Channel	Test Frequency (MHz)	Maximum Conducted Spurious Emissions Below 1GHz		Maximum Conducted Spurious Emissions Above 1GHz		FCC Limit
				Frequency (MHz)	Datum (dBm)	Frequency (MHz)	Datum (dBm)	
FM	12.5KHz	Low	896.5000	683.20	-28.96	8524.00	-25.90	-20dBm
Test Results				Compliance				

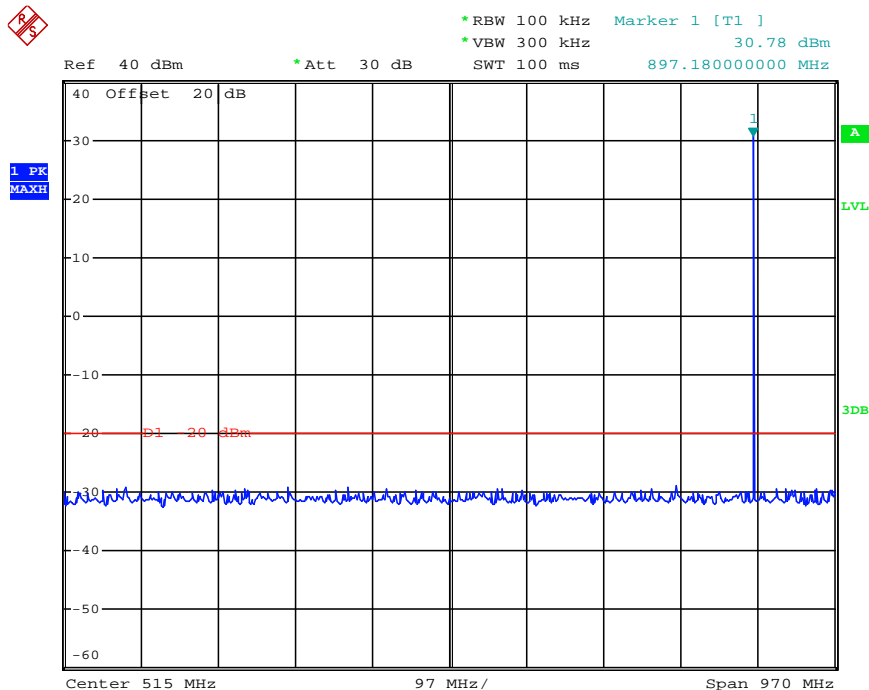

Date: 3.APR.2013 17:24:57

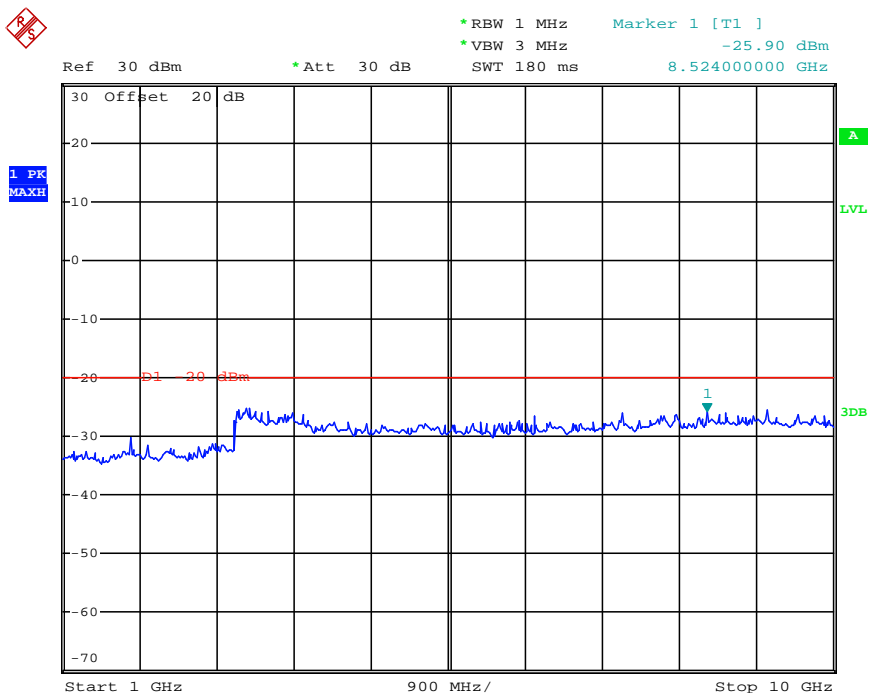

Date: 3.APR.2013 17:35:54

Modulation Type	Channel SpARATION	Test Channel	Test Frequency (MHz)	Maximum Conducted Spurious Emissions Below 1GHz		Maximum Conducted Spurious Emissions Above 1GHz		FCC Limit
				Frequency (MHz)	Datum (dBm)	Frequency (MHz)	Datum (dBm)	
FM	12.5KHz	High	900.5000	665.24	-29.78	8506.00	-25.36	-20dBm
Test Results				Compliance				

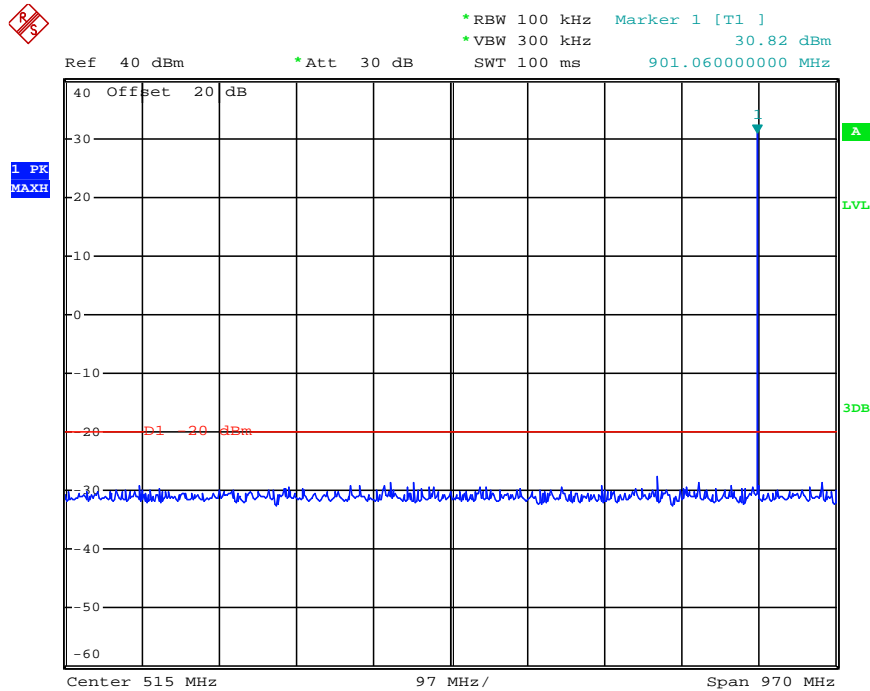

Date: 3.APR.2013 17:25:30

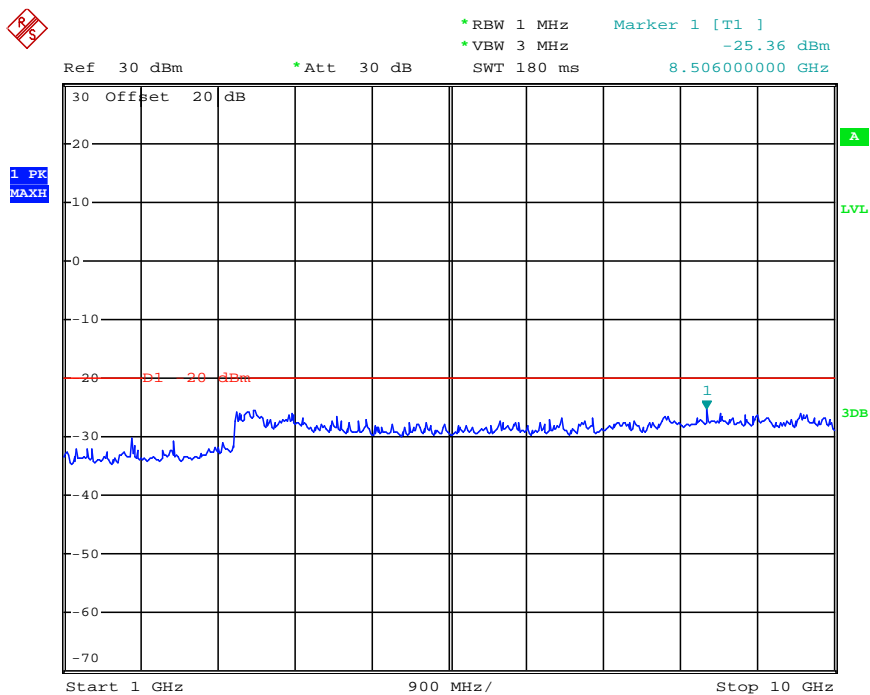

Date: 3.APR.2013 17:36:22

Modulation Type	Channel Sparation	Test Channel	Test Frequency (MHz)	Maximum Conducted Spurious Emissions Below 1GHz		Maximum Conducted Spurious Emissions Above 1GHz		FCC Limit
				Frequency (MHz)	Datum (dBm)	Frequency (MHz)	Datum (dBm)	
FM	12.5KHz	Low	935.5000	986.22	-29.55	9586.00	-25.20	-20dBm
Test Results				Compliance				

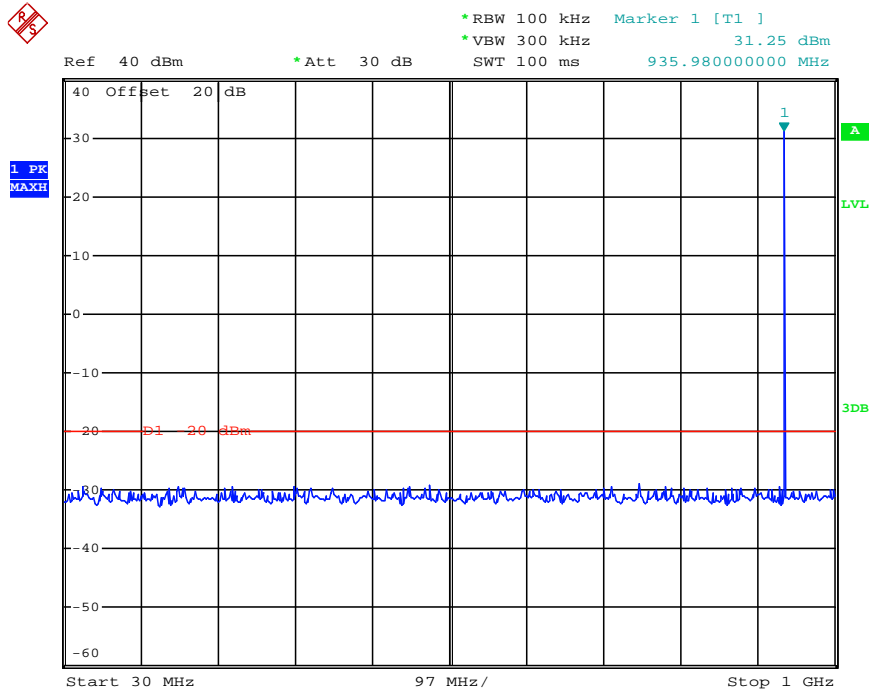

Date: 3.APR.2013 18:00:58

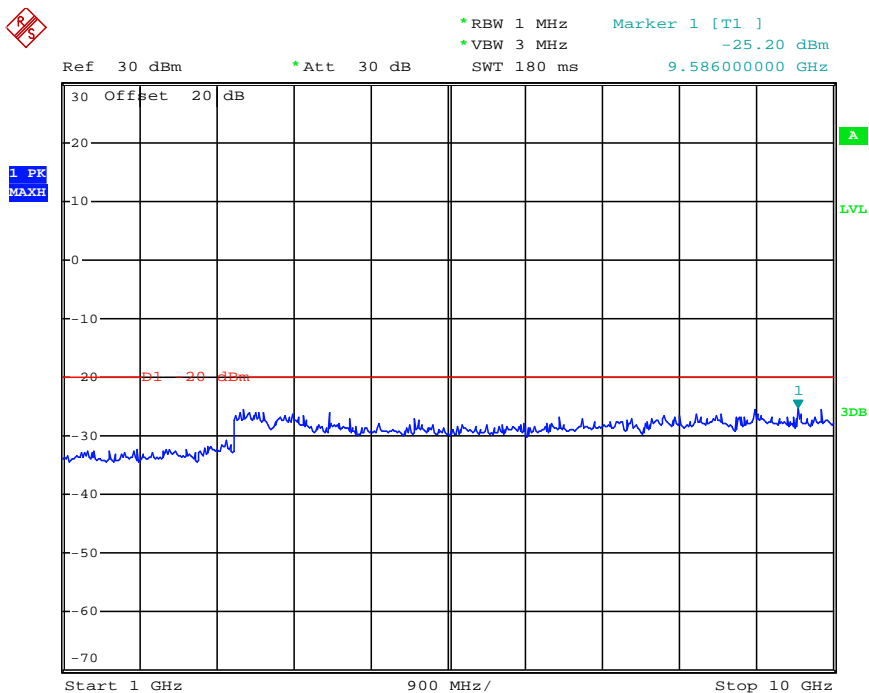

Date: 3.APR.2013 17:51:22

Modulation Type	Channel Sparation	Test Channel	Test Frequency (MHz)	Maximum Conducted Spurious Emissions Below 1GHz		Maximum Conducted Spurious Emissions Above 1GHz		FCC Limit
				Frequency (MHz)	Datum (dBm)	Frequency (MHz)	Datum (dBm)	
FM	12.5KHz	High	939.5000	638.54	-29.44	3196.00	-25.56	-20dBm
Test Results				Compliance				

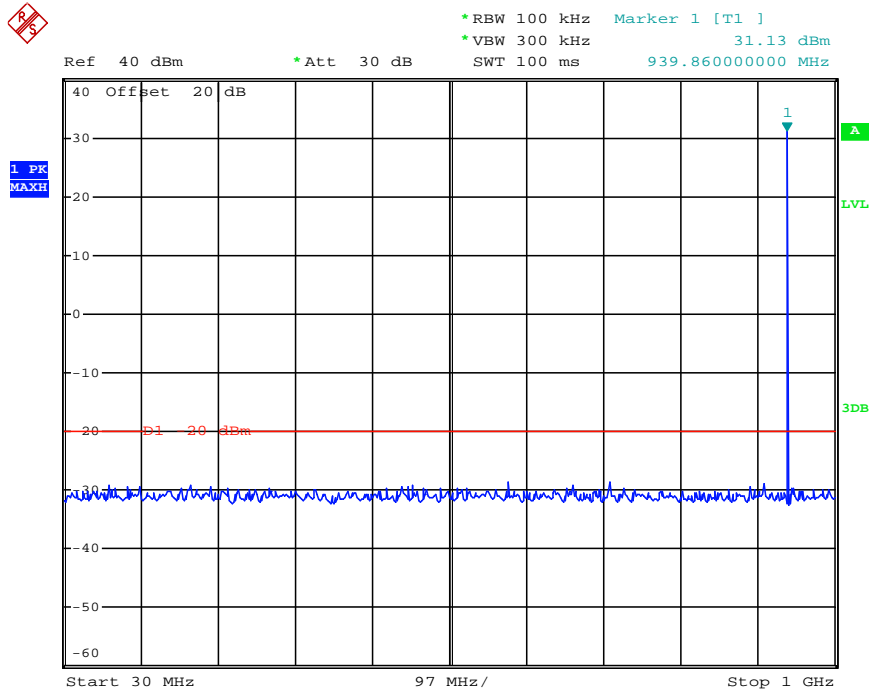

Date: 3.APR.2013 18:01:26

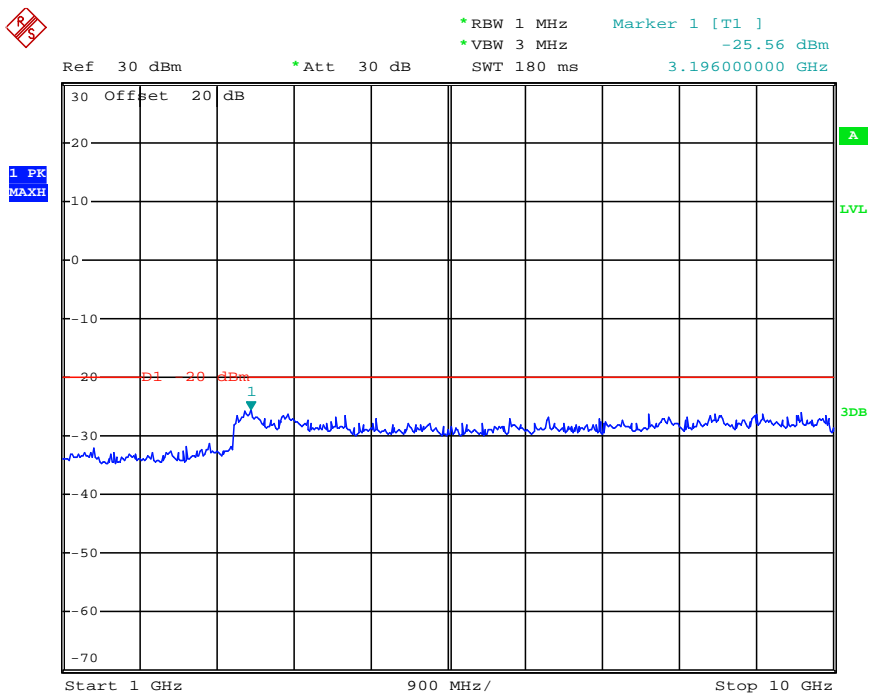

Date: 3.APR.2013 17:51:51

Modulation Type	Channel Separation	Test Channel	Test Frequency (MHz)	Maximum Conducted Spurious Emissions Below 1GHz		Maximum Conducted Spurious Emissions Above 1GHz		FCC Limit
				Frequency (MHz)	Datum (dBm)	Frequency (MHz)	Datum (dBm)	
4FSk	12.5KHz	Low	806.5000	874.21	-29.06	3124.00	-25.38	-20dBm
Test Results				Compliance				

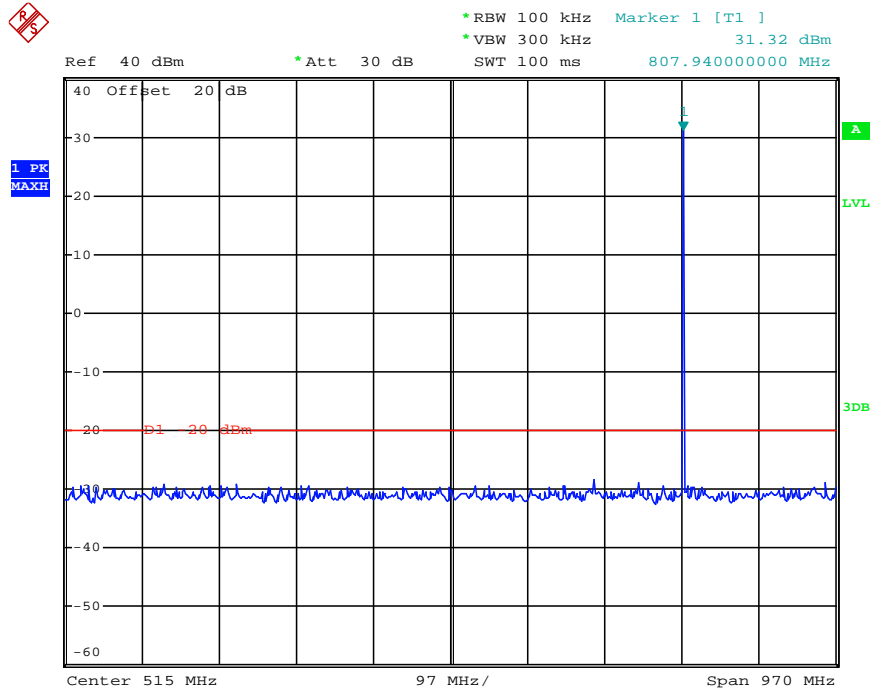

Date: 3.APR.2013 17:30:23

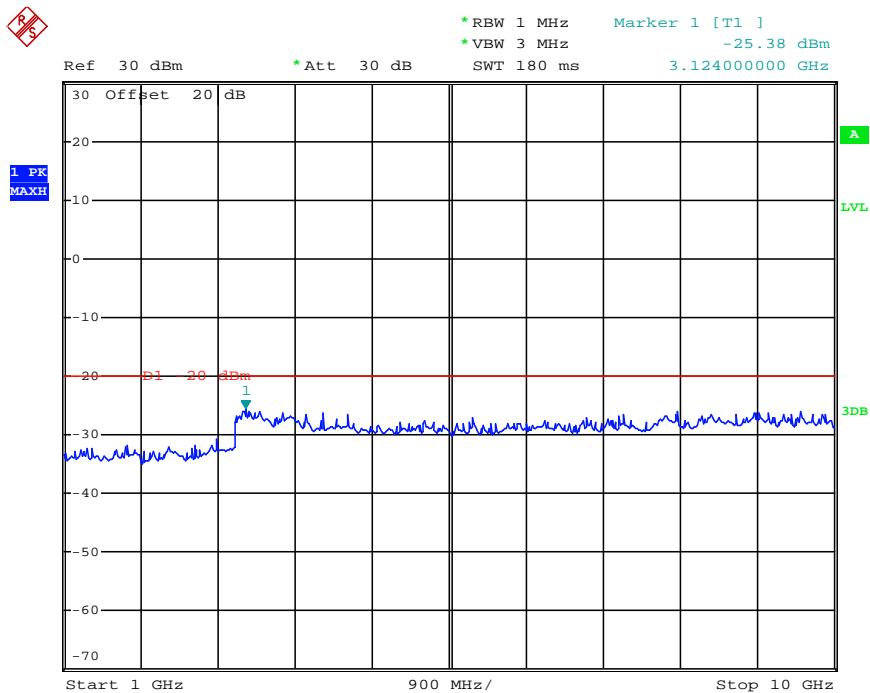

Date: 3.APR.2013 17:37:01

Modulation Type	Channel SpARATION	Test Channel	Test Frequency (MHz)	Maximum Conducted Spurious Emissions Below 1GHz		Maximum Conducted Spurious Emissions Above 1GHz		FCC Limit
				Frequency (MHz)	Datum (dBm)	Frequency (MHz)	Datum (dBm)	
4FSK	12.5KHz	Middle	817.0000	568.54	-29.85	9226.00	-25.67	-20dBm
Test Results				Compliance				

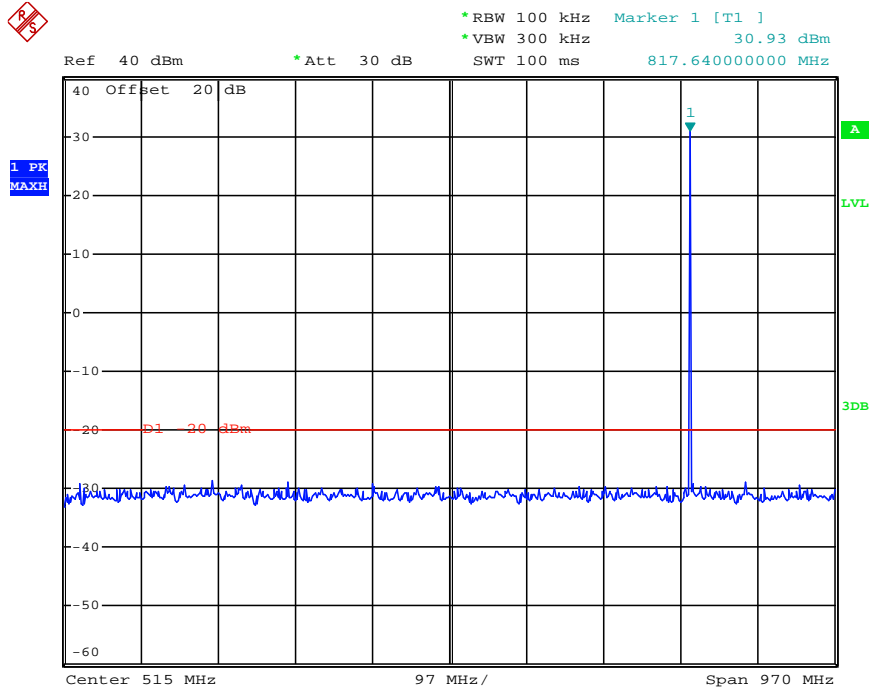

Date: 3.APR.2013 17:29:53

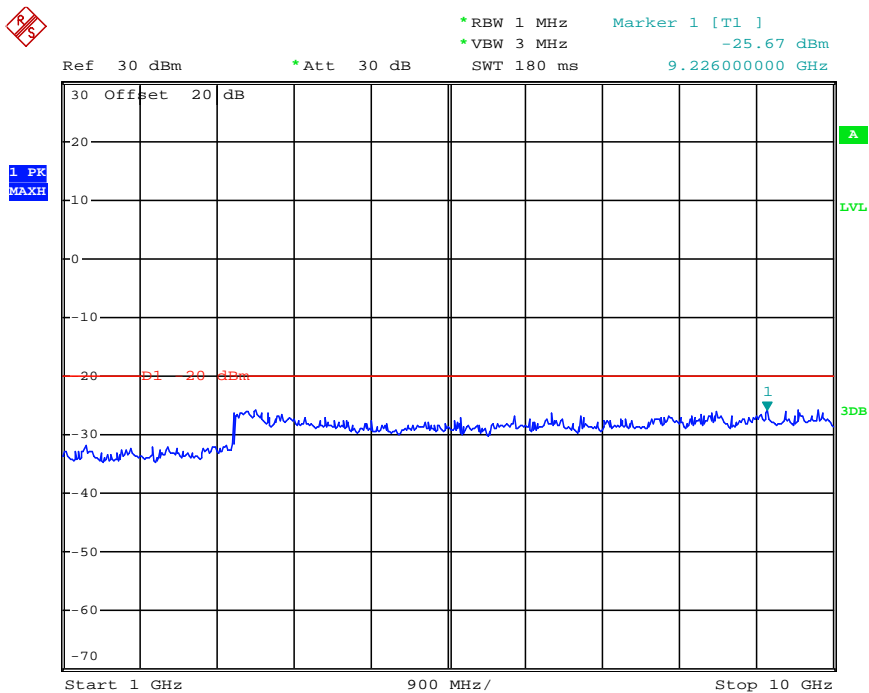

Date: 3.APR.2013 17:37:36

Modulation Type	Channel Separation	Test Channel	Test Frequency (MHz)	Maximum Conducted Spurious Emissions Below 1GHz		Maximum Conducted Spurious Emissions Above 1GHz		FCC Limit
				Frequency (MHz)	Datum (dBm)	Frequency (MHz)	Datum (dBm)	
4FSK	12.5KHz	High	823.5000	653.52	-28.99	3070.00	-26.43	-20dBm
Test Results				Compliance				

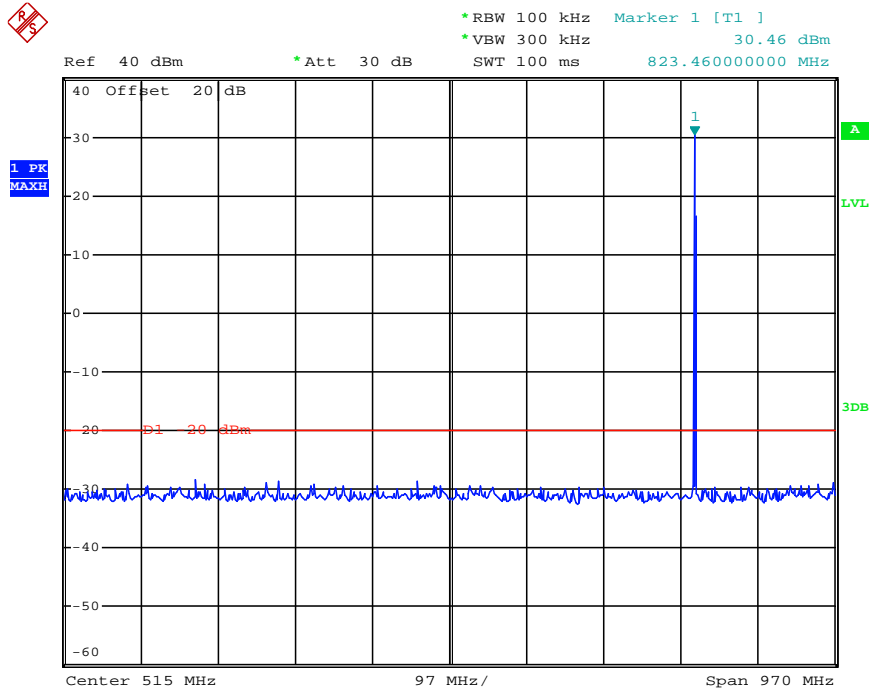

Date: 3.APR.2013 17:30:49

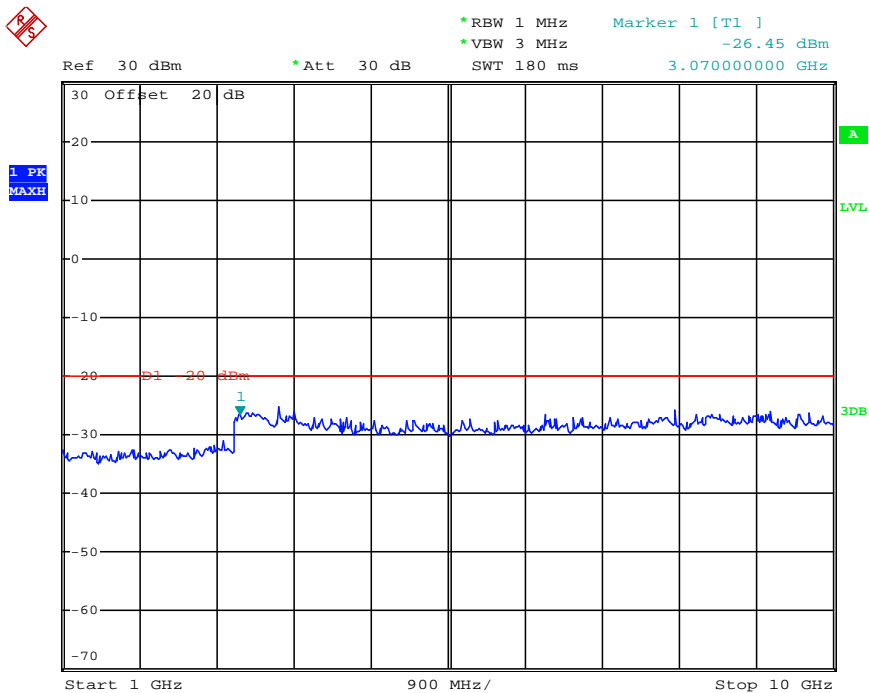

Date: 3.APR.2013 17:38:02

Modulation Type	Channel Sparation	Test Channel	Test Frequency (MHz)	Maximum Conducted Spurious Emissions Below 1GHz		Maximum Conducted Spurious Emissions Above 1GHz		FCC Limit
				Frequency (MHz)	Datum (dBm)	Frequency (MHz)	Datum (dBm)	
4FSK	12.5KHz	Low	851.5000	886.54	-29.88	9244.00	-27.75	-20dBm
Test Results				Compliance				

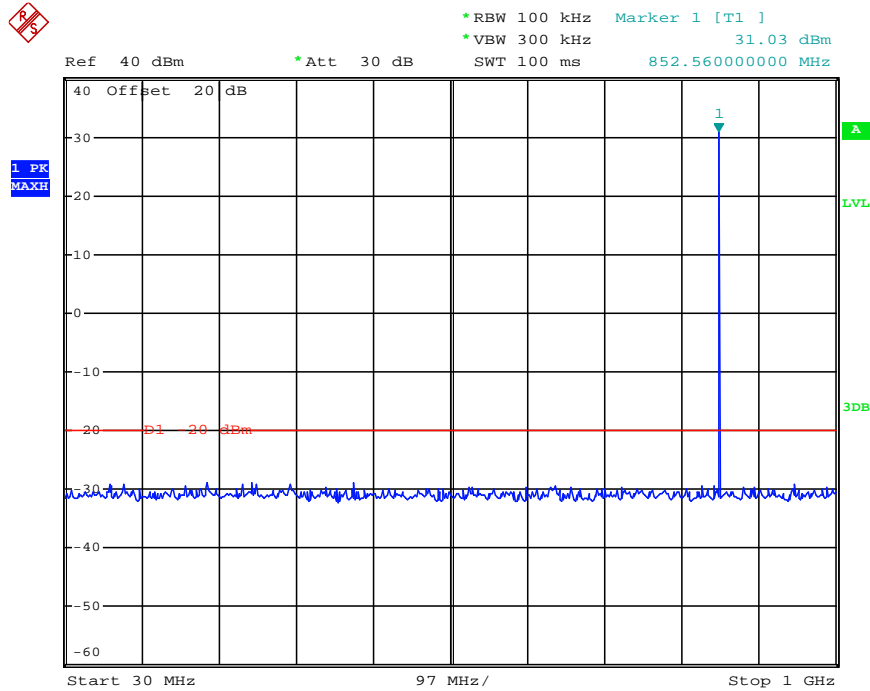

Date: 3.APR.2013 18:02:12

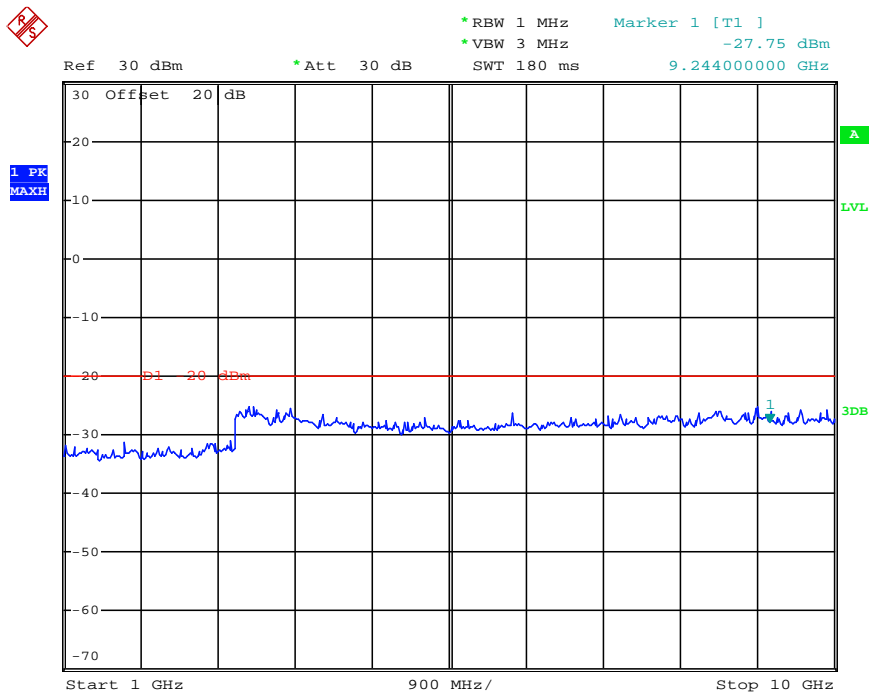

Date: 3.APR.2013 17:52:33

Modulation Type	Channel Sparation	Test Channel	Test Frequency (MHz)	Maximum Conducted Spurious Emissions Below 1GHz		Maximum Conducted Spurious Emissions Above 1GHz		FCC Limit
				Frequency (MHz)	Datum (dBm)	Frequency (MHz)	Datum (dBm)	
4FSK	12.5KHz	Middle	860.0000	635.55	-28.95	3124.00	-25.87	-20dBm
Test Results				Compliance				

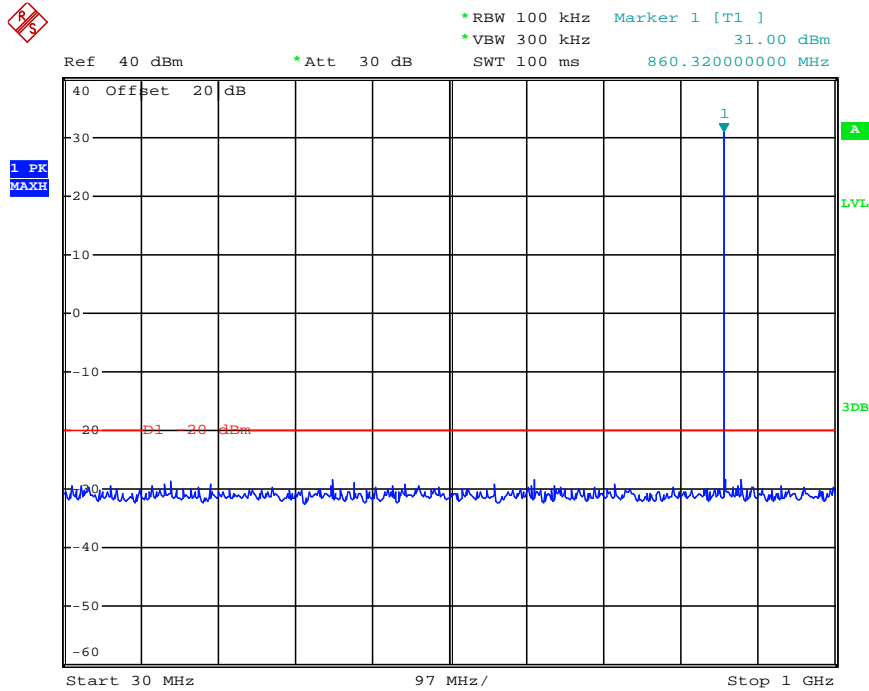

Date: 3.APR.2013 18:02:38

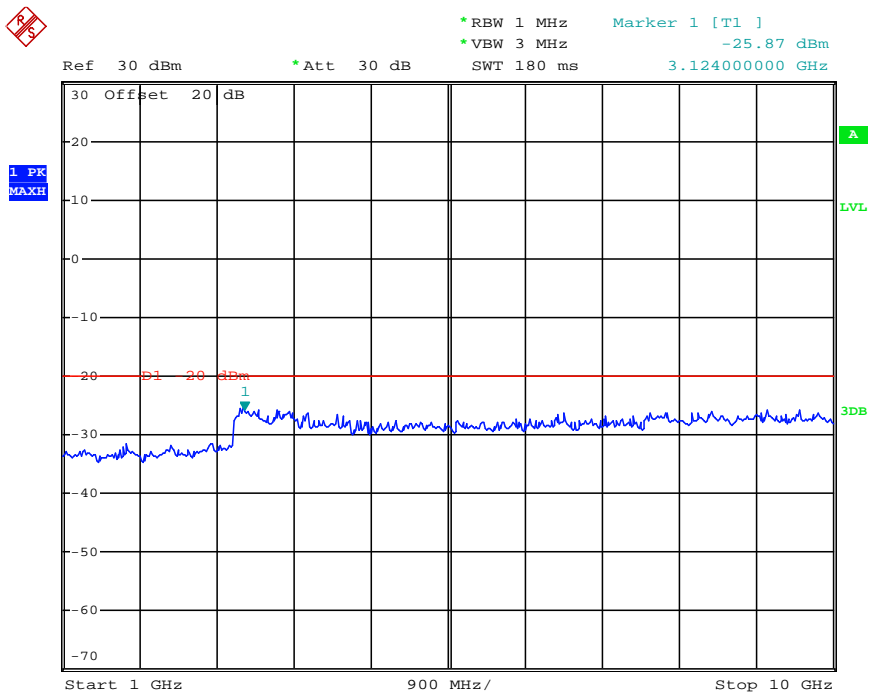

Date: 3.APR.2013 17:53:10

Modulation Type	Channel Sparation	Test Channel	Test Frequency (MHz)	Maximum Conducted Spurious Emissions Below 1GHz		Maximum Conducted Spurious Emissions Above 1GHz		FCC Limit
				Frequency (MHz)	Datum (dBm)	Frequency (MHz)	Datum (dBm)	
4FSK	12.5KHz	High	868.5000	785.22	-28.95	3574.00	-25.79	-20dBm
Test Results				Compliance				

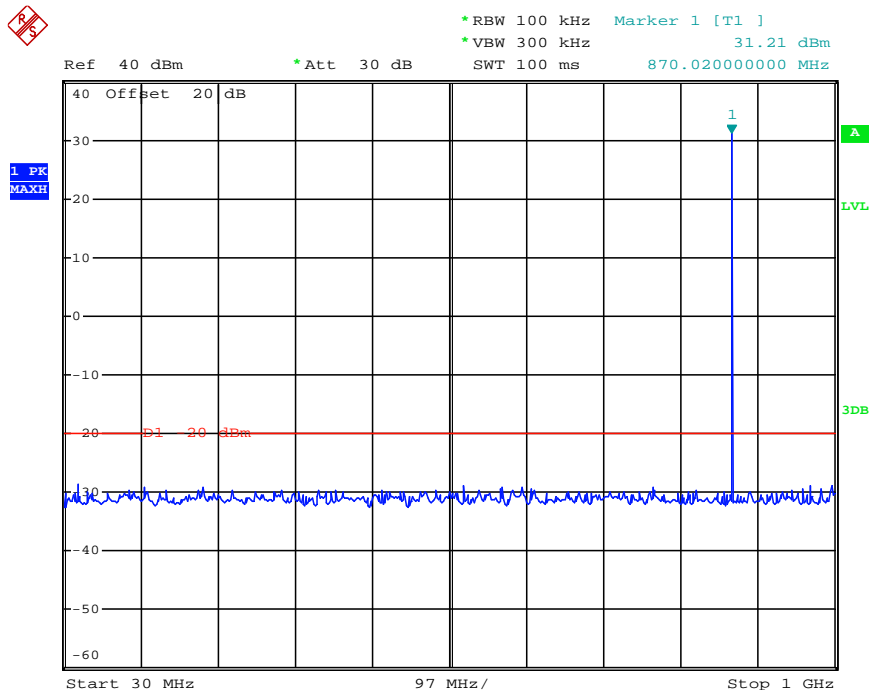

Date: 3.APR.2013 18:03:23

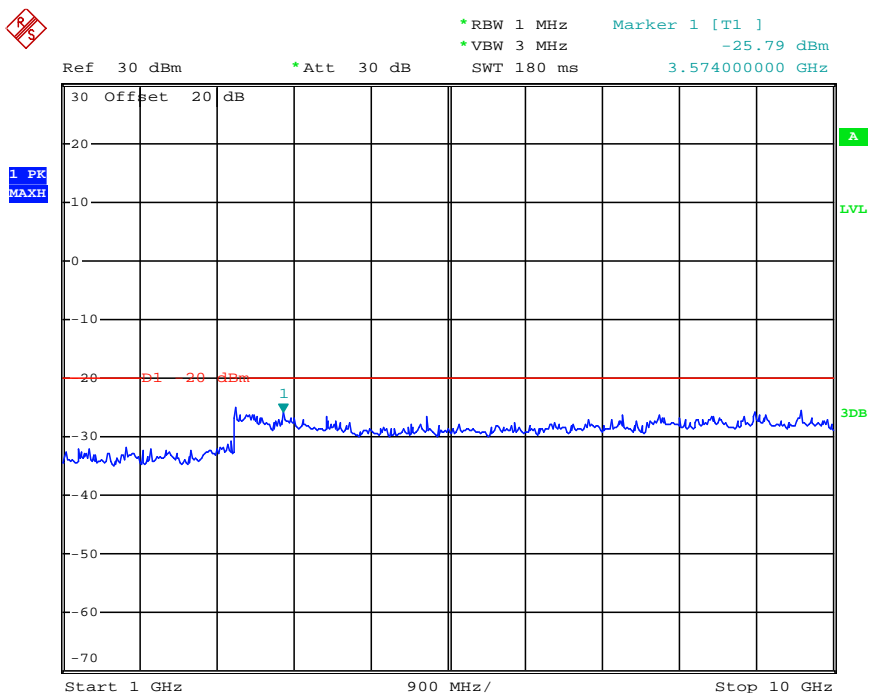

Date: 3.APR.2013 17:53:36

Modulation Type	Channel Sparation	Test Channel	Test Frequency (MHz)	Maximum Conducted Spurious Emissions Below 1GHz		Maximum Conducted Spurious Emissions Above 1GHz		FCC Limit
				Frequency (MHz)	Datum (dBm)	Frequency (MHz)	Datum (dBm)	
4FSK	12.5KHz	Low	896.5000	976.54	-28.96	3070.00	-25.60	-20dBm
Test Results				Compliance				

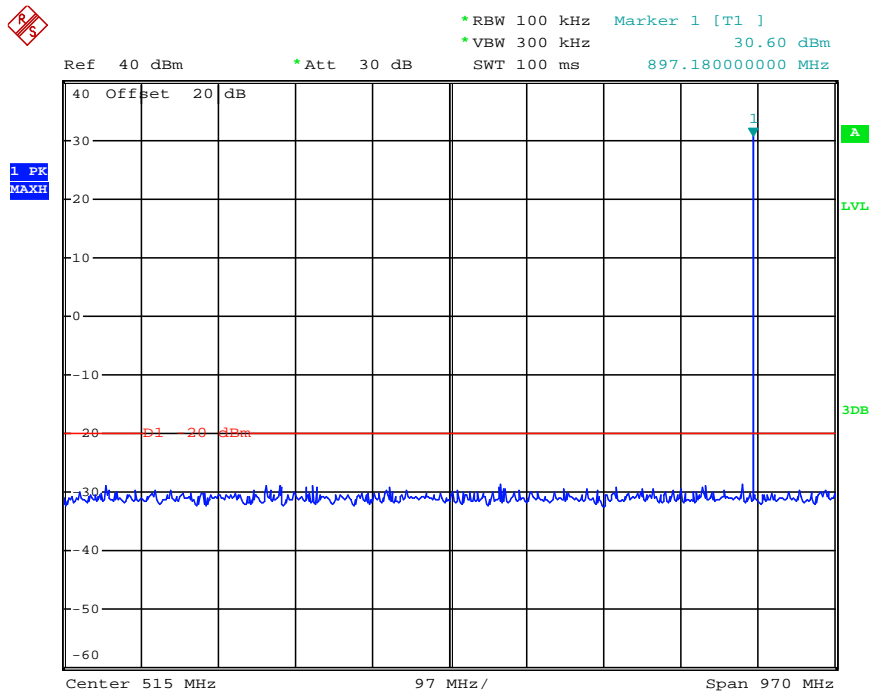

Date: 3.APR.2013 17:31:25

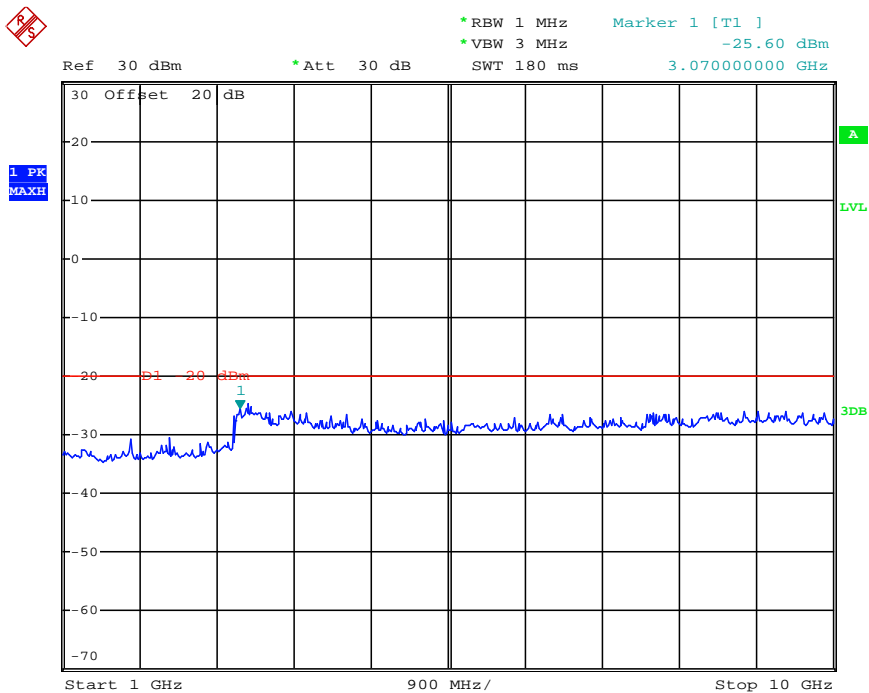

Date: 3.APR.2013 17:39:07

Modulation Type	Channel Sparation	Test Channel	Test Frequency (MHz)	Maximum Conducted Spurious Emissions Below 1GHz		Maximum Conducted Spurious Emissions Above 1GHz		FCC Limit
				Frequency (MHz)	Datum (dBm)	Frequency (MHz)	Datum (dBm)	
4FSK	12.5KHz	High	900.5000	753.52	-29.55	8524.00	-26.20	-20dBm
Test Results				Compliance				

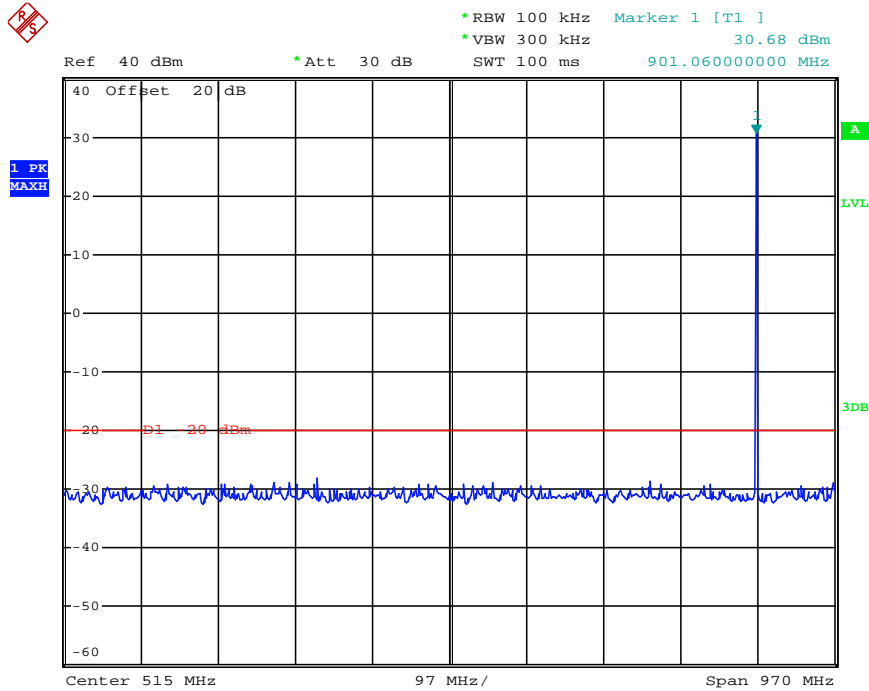

Date: 3.APR.2013 17:32:03

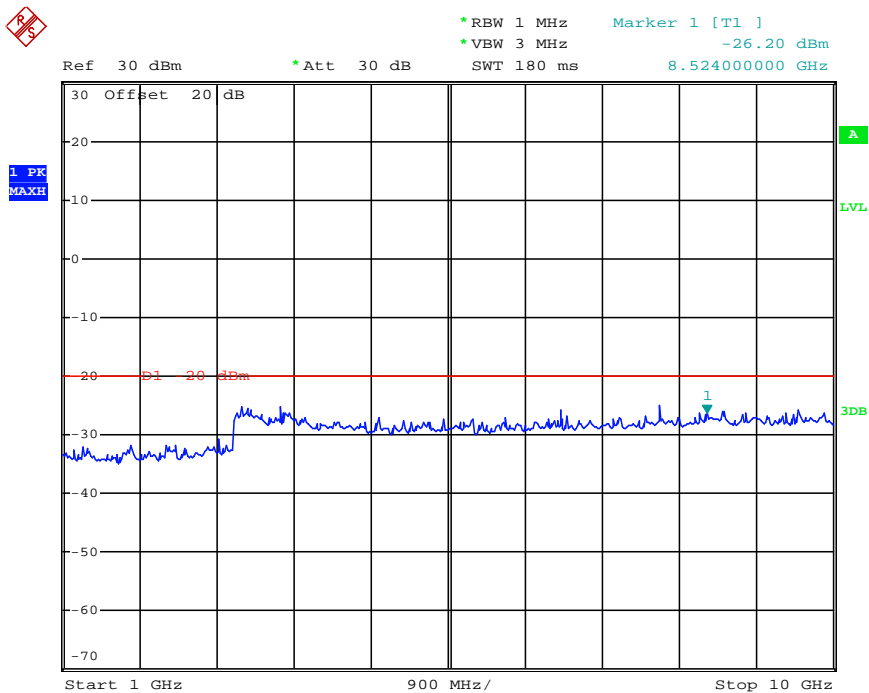

Date: 3.APR.2013 17:39:43

Modulation Type	Channel Sparation	Test Channel	Test Frequency (MHz)	Maximum Conducted Spurious Emissions Below 1GHz		Maximum Conducted Spurious Emissions Above 1GHz		FCC Limit
				Frequency (MHz)	Datum (dBm)	Frequency (MHz)	Datum (dBm)	
4FSK	12.5KHz	Low	935.5000	654.21	-28.92	9064.00	-26.01	-20dBm
Test Results				Compliance				

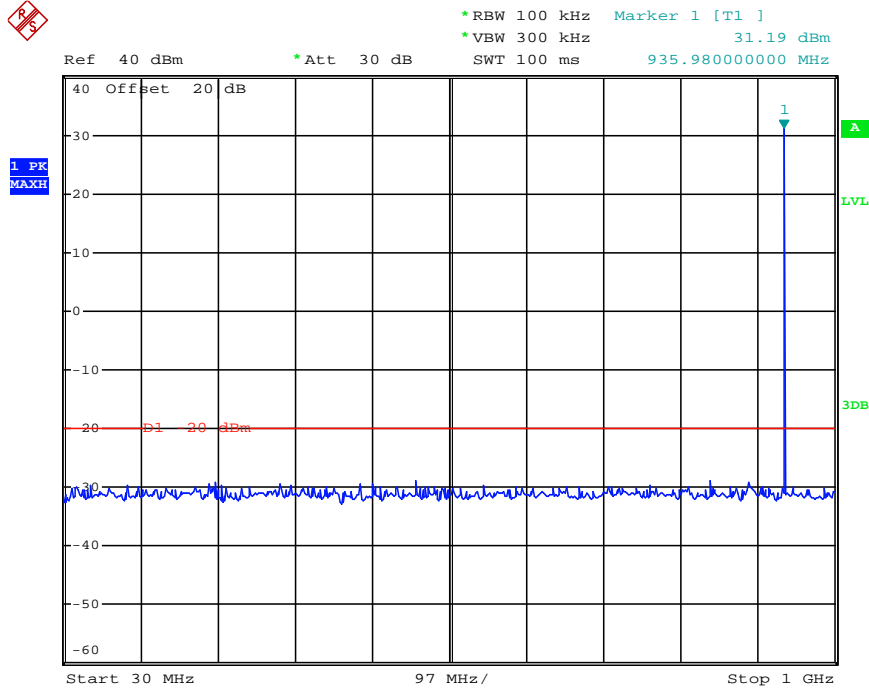

Date: 3.APR.2013 18:03:54

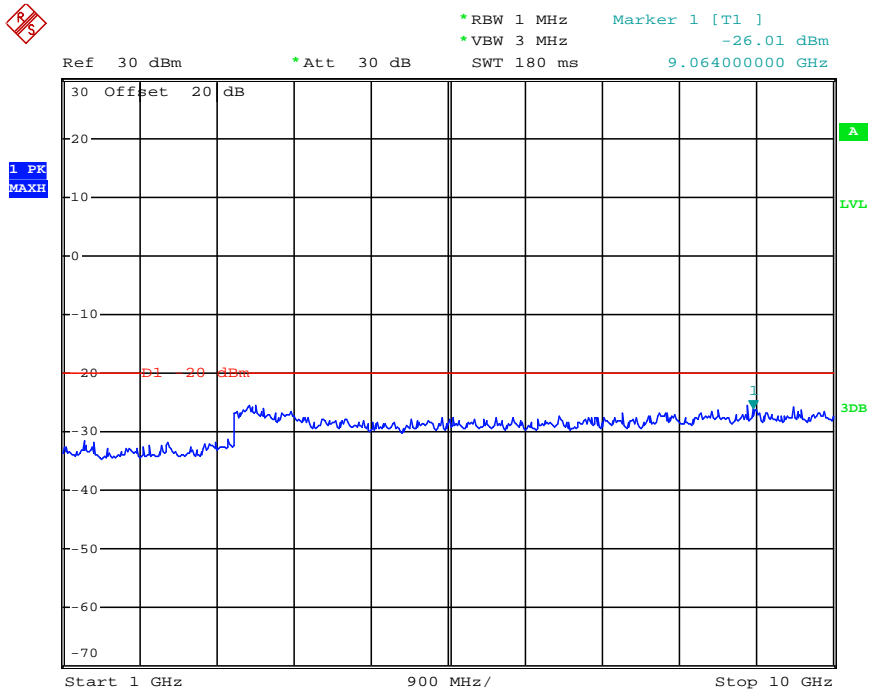

Date: 3.APR.2013 17:54:09

Modulation Type	Channel Sparation	Test Channel	Test Frequency (MHz)	Maximum Conducted Spurious Emissions Below 1GHz		Maximum Conducted Spurious Emissions Above 1GHz		FCC Limit
				Frequency (MHz)	Datum (dBm)	Frequency (MHz)	Datum (dBm)	
4FSK	12.5KHz	High	939.5000	856.02	-28.93	9208.00	-26.61	-20dBm
Test Results				Compliance				

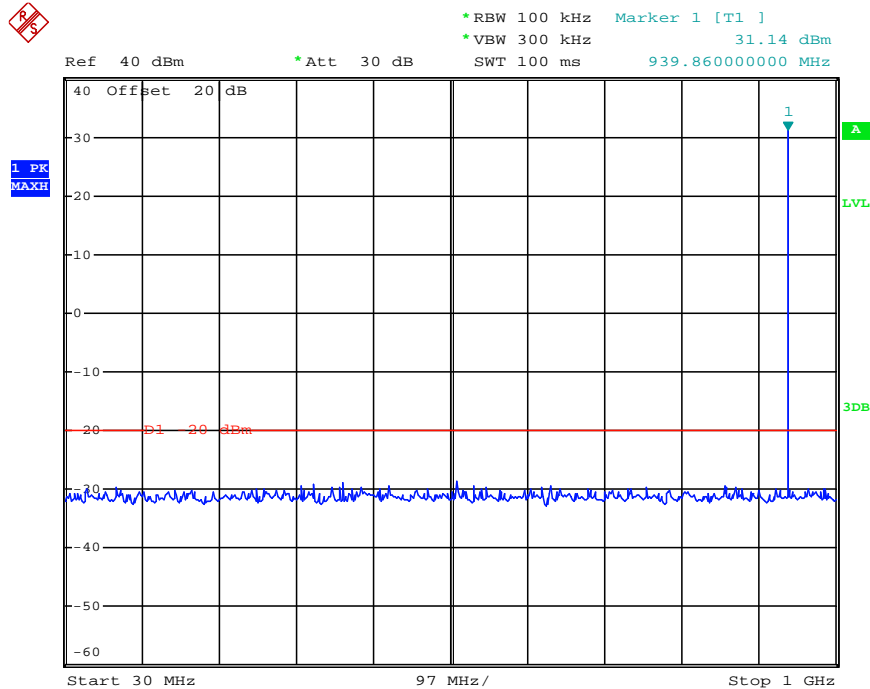

Date: 3.APR.2013 18:04:30

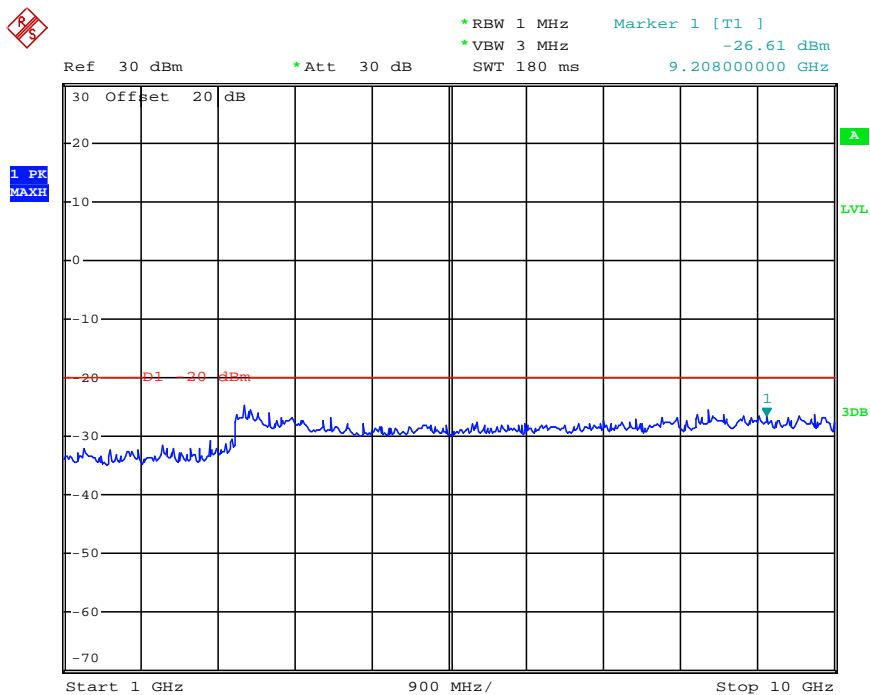

Date: 3.APR.2013 17:54:35

4.5. Modulation Characteristics

TEST APPLICABLE

According to CFR47 section 2.1047(a), for Voice Modulation Communication Equipment, the frequency response of the audio modulation circuit over a range of 100 to 5000Hz shall be measured.

TEST PROCEDURE

Modulation Limit

- 1 Configure the EUT as shown in figure 1, adjust the audio input for 60% of rated system deviation at 1 KHz using this level as a reference (0dB) and vary the input level from -20 to +20dB. Record the frequency deviation obtained as a function of the input level.
- 2 Repeat step 1 with input frequency changing to 300, 1004, 1500 and 2500Hz in sequence.

Audio Frequency Response

- 1 Configure the EUT as shown in figure 1.
- 2 Adjust the audio input for 20% of rated system deviation at 1 KHz using this level as a reference (0dB).
- 3 Vary the Audio frequency from 100 Hz to 3 KHz and record the frequency deviation.
- 4 Audio Frequency Response = $20\log_{10} (\text{Deviation of test frequency} / \text{Deviation of 1 KHz reference})$.

TEST CONFIGURATION

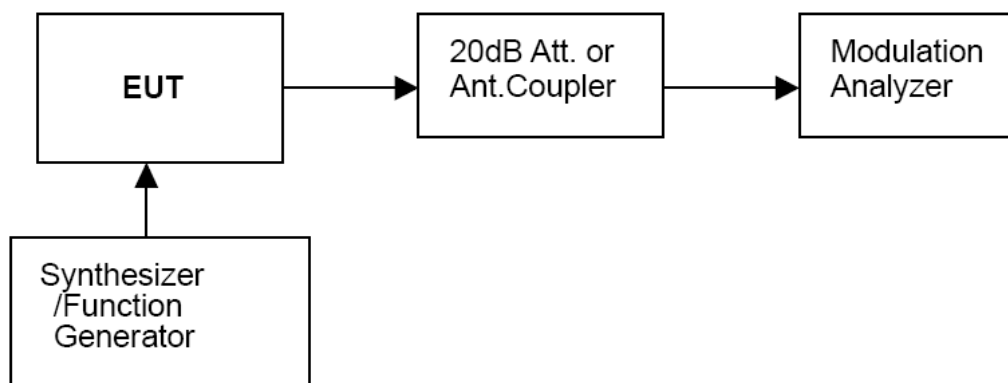

TEST RESULTS

Modulation Type: FM

25 KHz Channel Separation

Modulation Level(dB)	Peak Freq. Deviation At 300 Hz(KHz)	Peak Freq. Deviation At 1004 Hz(KHz)	Peak Freq. Deviation At 1500 Hz(KHz)	Peak Freq. Deviation At 2500 Hz(KHz)
-20	0.15	0.36	0.75	1.17
-15	0.14	0.58	1.56	2.45
-10	0.55	1.09	2.76	4.18
-5	0.79	3.09	4.35	4.19
0	0.76	3.08	4.38	4.18
+5	0.74	2.95	4.39	4.15
+10	0.74	3.14	4.45	4.18
+15	1.34	4.74	4.44	4.17
+20	2.38	4.58	4.45	4.15