



# OET 65

# TEST REPORT

<b>Product Name</b>	Digital Portable Radio
<b>Model</b>	PD782G U(5)
<b>FCC ID</b>	YAMPD78XGU5
<b>Client</b>	Hytera Communications Co.,Ltd.

**TA Technology (Shanghai) Co., Ltd.**

**TA Technology (Shanghai) Co., Ltd.**  
**Test Report**

Report No. RZA1203-0346SAR

Page 2 of 98

**GENERAL SUMMARY**

<b>Product Name</b>	Digital Portable Radio	<b>Model</b>	PD782G U(5)
<b>FCC ID</b>	YAMPD78XGU5	<b>Report No.</b>	RZA1203-0346SAR
<b>Client</b>	Hytera Communications Co.,Ltd.		
<b>Manufacturer</b>	Hytera Communications Co.,Ltd.		
<b>Reference Standard(s)</b>	<p><b>IEEE Std C95.1, 1999:</b> IEEE Standard for Safety Levels with Respect to Human Exposure to Radio Frequency Electromagnetic Fields, 3 KHz to 300 GHz.</p> <p><b>IEEE Std 1528™-2003:</b> IEEE Recommended Practice for Determining the Peak Spatial-Average Specific Absorption Rate (SAR) in the Human Head from Wireless Communications Devices: Measurement Techniques.</p> <p><b>SUPPLEMENT C Edition 01-01 to OET BULLETIN 65 Edition 97-01 June 2001 including DA 02-1438 June 19, 2002:</b> Evaluating Compliance with FCC Guidelines for Human Exposure to Radiofrequency Electromagnetic Fields Additional Information for Evaluation Compliance of Mobile and Portable Devices with FCC Limits for Human Exposure to Radiofrequency Emissions.</p> <p><b>KDB 643646 D01 SAR Test for PTT Radios v01:</b> SAR Test Reduction Considerations for Occupational PTT Radios</p> <p><b>KDB 447498 D01 Mobile Portable RF Exposure v04:</b> Mobile and Portable Device RF Exposure Procedures and Equipment Authorization Policies</p>		
<b>Conclusion</b>	<p>This portable wireless equipment has been measured in all cases requested by the relevant standards. Test results in Chapter 7 of this test report are below limits specified in the relevant standards.</p> <p>General Judgment: <b>Pass</b></p> <p style="text-align: right;">(Stamp) Date of issue: <b>March 30<sup>th</sup>, 2012</b></p>		
<b>Comment</b>	The test result only responds to the measured sample.		

Approved by 初伟中  
Director

Revised by 凌敏宝  
SAR Manager

Performed by 张先金  
SAR Engineer

## TABLE OF CONTENT

1. General Information .....	5
1.1. Notes of the Test Report.....	5
1.2. Testing Laboratory .....	5
1.3. Applicant Information .....	6
1.4. Manufacturer Information.....	6
1.5. Information of EUT.....	7
1.6. The Maximum SAR <sub>1g</sub> Values .....	8
1.7. Test Date .....	9
2. SAR Measurements System Configuration.....	10
2.1. SAR Measurement Set-up .....	10
2.2. DASY5 E-field Probe System .....	11
2.2.1. EX3DV4 Probe Specification .....	11
2.2.2. E-field Probe Calibration .....	12
2.3. Other Test Equipment .....	12
2.3.1. Device Holder for Transmitters .....	12
2.3.2. Phantom .....	13
2.4. Scanning Procedure .....	13
2.5. Data Storage and Evaluation .....	15
2.5.1. Data Storage.....	15
2.5.2. Data Evaluation by SEMCAD .....	15
3. Laboratory Environment.....	17
4. Tissue-equivalent Liquid .....	18
4.1. Tissue-equivalent Liquid Ingredients.....	18
4.2. Tissue-equivalent Liquid Properties .....	19
5. System Check.....	20
5.1. Description of System Check.....	20
5.2. System Check Results.....	21
6. Operational Conditions during Test .....	22
6.1. General Description of Test Procedures .....	22
6.2. Test Configuration .....	22
6.2.1. Face-Held Configuration .....	22
6.2.2. Body-Worn Configuration .....	22
7. Test Results .....	23
7.1. Conducted Power Results .....	23
7.2. SAR Test Results .....	24
8. Measurement Uncertainty .....	28
9. Main Test Instruments .....	30
ANNEX A: Test Layout .....	31
ANNEX B: System Check Results .....	32
ANNEX C: Graph Results .....	34

**TA Technology (Shanghai) Co., Ltd.**  
**Test Report**

Report No. RZA1203-0346SAR

Page 4 of 98

---

ANNEX D: Probe Calibration Certificate .....	54
ANNEX E: D835V2 Dipole Calibration Certificate .....	65
ANNEX F: DAE4 Calibration Certificate .....	73
ANNEX G: The EUT Appearances and Test Configuration .....	78

## 1. General Information

### 1.1. Notes of the Test Report

**TA Technology (Shanghai) Co., Ltd.** guarantees the reliability of the data presented in this test report, which is the results of measurements and tests performed for the items under test on the date and under the conditions stated in this test report and is based on the knowledge and technical facilities available at TA Technology (Shanghai) Co., Ltd. at the time of execution of the test.

**TA Technology (Shanghai) Co., Ltd.** is liable to the client for the maintenance by its personnel of the confidentiality of all information related to the items under test and the results of the test. This report only refers to the item that has undergone the test.

This report standalone dose not constitute or imply by its own an approval of the product by the certification Bodies or competent Authorities. This report cannot be used partially or in full for publicity and/or promotional purposes without previous written approval of **TA Technology (Shanghai) Co., Ltd.** and the Accreditation Bodies, if it applies.

If the electrical report is inconsistent with the printed one, it should be subject to the latter.

### 1.2. Testing Laboratory

Company: TA Technology (Shanghai) Co., Ltd.  
Address: No.145, Jintang Rd, Tangzhen Industry Park, Pudong Shanghai, China  
City: Shanghai  
Post code: 201201  
Country: P. R. China  
Contact: Yang Weizhong  
Telephone: +86-021-50791141/2/3  
Fax: +86-021-50791141/2/3-8000  
Website: <http://www.ta-shanghai.com>  
E-mail: [yangweizhong@ta-shanghai.com](mailto:yangweizhong@ta-shanghai.com)

# TA Technology (Shanghai) Co., Ltd.

## Test Report

Report No. RZA1203-0346SAR

Page 6 of 98

---

### 1.3. Applicant Information

Company: Hytera Communications Co.,Ltd.  
Address: Hytera Tower,Hi-Tech Industrial Park North, Nanshan District,Shenzhen China  
City: Shenzhen  
Postal Code: 518057  
Country: P. R. China  
Telephone: +86-0755-26972999- 1210  
Fax: +86 755 86137130

### 1.4. Manufacturer Information

Company: Hytera Communications Co.,Ltd.  
Address: Hytera Tower,Hi-Tech Industrial Park North, Nanshan District,Shenzhen China  
City: Shenzhen  
Postal Code: 518057  
Country: P. R. China  
Telephone: +86-0755-26972999- 1210  
Fax: 0755-86137130

**TA Technology (Shanghai) Co., Ltd.**  
**Test Report**

Report No. RZA1203-0346SAR

Page 7 of 98

**1.5. Information of EUT**

**General Information**

Device Type:	Portable Device
Exposure Category:	Controlled Environment /Occupational
State of Sample:	Prototype Unit
Product Name:	Digital Portable Radio
S/N:	/
Hardware Version:	41PD7801001F0
Software Version:	v4.05.08
Antenna Type:	External Antenna
Device Operating Configurations:	
Test Modulation:	FM (Analog), 4FSK(Digital)
Operating Frequency Range(s):	806.5MHz – 938MHz (UHF)
Test Frequency:	806.5MHz – 824.5MHz – 851.5MHz – 869.5MHz – 899MHz – 938MHz
Note: 1. The test channels were selected in accordance with the procedures specified in FCC KDB 447498 D01 Mobile Portable RF Exposure v04 Section 6) c).	

# TA Technology (Shanghai) Co., Ltd.

## Test Report

Report No. RZA1203-0346SAR

Page 8 of 98

### Auxiliary Equipment Details

Accessory Name for Test Report	Model	Description	Manufacturer	
<b>Battery</b>			Hytera Communications Co.,Ltd.	
Thicker Battery	BL2503	Battery,Li-Ion 2500 mAh,DMR		
Thinner Battery	BL2006	Battery,Li-Ion 2000 mAh,DMR		
<b>Body-worn</b>				
Belt	BC19	Belt Clip,DMR		
Pocket	LCY003	Case, leather w/Swivel,DMR		
Chest Pack1	LCBN13	Belt Clip		
<b>Audio</b>				
Earphone 1	ESS07	Earbud,Receive Only,DMR		
Earphone 2	ESS08	Earpiece,Receive Only,DMR		
Accessory 1	SM18N2	Speaker Mic, Water-Proof Remote,DMR		
Audio Accessory 2	EHN12	D-Earset, w/ In-Line Mic and PTT,DMR		
Audio Accessory 3	EAN16	Earpiece, w/ On-Mic PTT,DMR		
Audio Accessory 4	EAN18	Earpiece, 3-wire Surveillance Kit,DMR		
Audio Accessory 5	ESN10	Earbud, w/ On-Mic PTT,DMR		
<p>Note 1. The Chest Pack provide an extra protection to the operator under RF exposure due to special measures taken during design and manufacturing process. Chest Pack is designed allow the radio only stick to it with belt-clip, the belt-clip will provide necessary distance between antenna and operator's body. The operator should follow Chest Pack usage instruction to ensure compliance with RF energy exposure limits. According to OET 65C, when multiple accessories that don't contain metallic components are supplied with the device, the device may be tested with only the accessory that dictates the closest spacing to the body. Because the spacing of combination Chest Pack and belt-clip is higher than only belt-clip, SAR is not required for combination Chest Pack and belt-clip state.</p>				

Equipment Under Test (EUT) is a Digital Portable Radio. SAR is tested for 806.5 - 938.0 MHz only. The EUT has one external antenna that is used for Tx/Rx.

The sample undergoing test was selected by the Client.

Components list please refer to documents of the manufacturer.



**TA Technology (Shanghai) Co., Ltd.**  
**Test Report**

Report No. RZA1203-0346SAR

Page 9 of 98

---

**1.6. The Maximum SAR<sub>1g</sub> Values**

Mode	Frequency (MHz)	Position	SAR <sub>1g</sub> (W/kg) 50% PTT duty cycle
UHF	851.5	Face-held	<b>1.535</b>
UHF	851.5	Body-Worn	<b>4.017</b>

**1.7. Test Date**

**The test performed from March 19, 2012 to March 20, 2012.**

## 2. SAR Measurements System Configuration

### 2.1. SAR Measurement Set-up

The DASY5 system for performing compliance tests consists of the following items:

- A standard high precision 6-axis robot (Stäubli RX family) with controller and software. An arm extension for accommodating the data acquisition electronics (DAE).
- A dosimetric probe, i.e. an isotropic E-field probe optimized and calibrated for usage in tissue simulating liquid. The probe is equipped with an optical surface detector system.
- A data acquisition electronic (DAE) which performs the signal amplification, signal multiplexing, AD-conversion, offset measurements, mechanical surface detection, collision detection, etc. The unit is battery powered with standard or rechargeable batteries. The signal is optically transmitted to the EOC.
- A unit to operate the optical surface detector which is connected to the EOC.
- The Electro-Optical Coupler (EOC) performs the conversion from the optical into a digital electric signal of the DAE. The EOC is connected to the DASY5 measurement server.
- The DASY5 measurement server, which performs all real-time data evaluation for field measurements and surface detection, controls robot movements and handles safety operation. A computer operating Windows 2003
- DASY5 software and SEMCAD data evaluation software.
- Remote control with teach panel and additional circuitry for robot safety such as warning lamps, etc.
- The generic twin phantom enabling the testing of left-hand and right-hand usage.
- The device holder for handheld mobile phones.
- Tissue simulating liquid mixed according to the given recipes.
- System validation dipoles allowing to validate the proper functioning of the system.

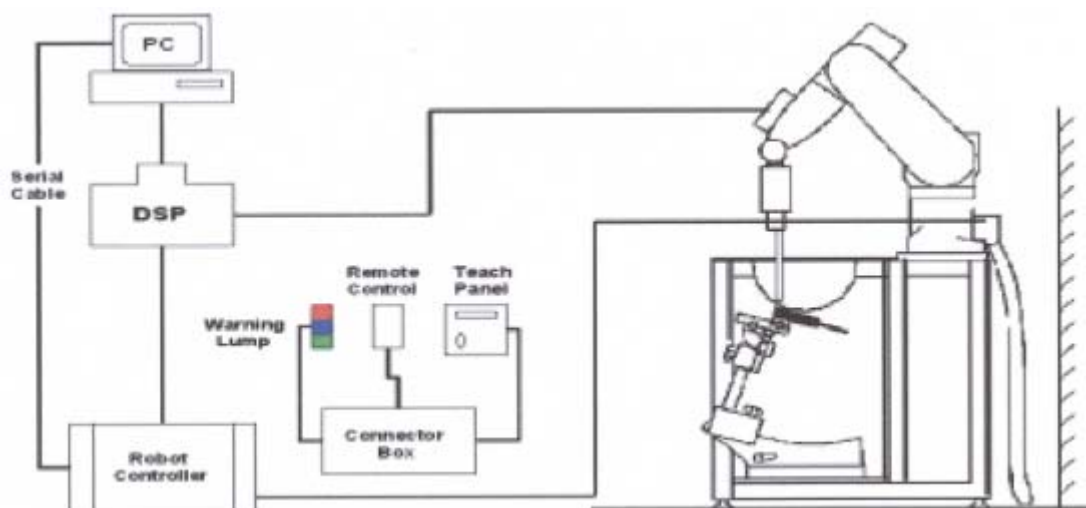

Figure 1. SAR Lab Test Measurement Set-up

## 2.2. DASY5 E-field Probe System

The SAR measurements were conducted with the dosimetric probe EX3DV4 (manufactured by SPEAG), designed in the classical triangular configuration and optimized for dosimetric evaluation.

### 2.2.1. EX3DV4 Probe Specification

Construction	Symmetrical design with triangular core Built-in shielding against static charges PEEK enclosure material (resistant to organic solvents, e.g., DGBE)
Calibration	ISO/IEC 17025 calibration service available
Frequency	10MHz to > 6 GHz Linearity: $\pm 0.2$ dB (30MHz to 6 GHz)
Directivity	$\pm 0.3$ dB in HSL (rotation around probe axis) $\pm 0.5$ dB in tissue material (rotation normal to probe axis)
Dynamic Range	10 $\mu$ W/g to > 100 mW/g Linearity: $\pm 0.2$ dB (noise: typically < 1 $\mu$ W/g)
Dimensions	Overall length: 330 mm (Tip: 20 mm) Tip diameter: 2.5 mm (Body: 12 mm) Typical distance from probe tip to dipole centers: 1 mm
Application	High precision dosimetric measurements in any exposure scenario (e.g., very strong gradient fields). Only probe which enables compliance testing for frequencies up to 6 GHz with precision of better 30%.



Figure 2. EX3DV4 E-field Probe



Figure 3. EX3DV4 E-field probe

### 2.2.2. E-field Probe Calibration

Each probe is calibrated according to a dosimetric assessment procedure with accuracy better than  $\pm 10\%$ . The spherical isotropy was evaluated and found to be better than  $\pm 0.25\text{dB}$ . The sensitivity parameters (NormX, NormY, NormZ), the diode compression parameter (DCP) and the conversion factor (ConvF) of the probe are tested.

The free space E-field from amplified probe outputs is determined in a test chamber. This is performed in a TEM cell for frequencies below 1 GHz, and in a wave guide above 1 GHz for free space. For the free space calibration, the probe is placed in the volumetric center of the cavity and at the proper orientation with the field. The probe is then rotated 360 degrees.

E-field temperature correlation calibration is performed in a flat phantom filled with the appropriate simulated brain tissue. The measured free space E-field in the medium correlates to temperature rise in a dielectric medium. For temperature correlation calibration a RF transparent thermistor-based temperature probe is used in conjunction with the E-field probe.

$$\text{SAR} = C \frac{\Delta T}{\Delta t}$$

Where:  $\Delta t$  = Exposure time (30 seconds),  
C = Heat capacity of tissue (brain or muscle),  
 $\Delta T$  = Temperature increase due to RF exposure.  
Or

$$\text{SAR} = \frac{|E|^2 \sigma}{\rho}$$

Where:  
 $\sigma$  = Simulated tissue conductivity,  
 $\rho$  = Tissue density (kg/m<sup>3</sup>).

## 2.3. Other Test Equipment

### 2.3.1. Device Holder for Transmitters

The DASY device holder is designed to cope with the different positions given in the standard.

It has two scales for device rotation (with respect to the body axis) and device inclination (with respect to the line between the ear reference points). The rotation centers for both scales is the ear reference point (ERP). Thus the device needs no repositioning when changing the angles.

The DASY device holder is constructed of low-loss POM material. The amount of dielectric material

has been reduced in the closest vicinity of the device, since measurements have suggested that the inference of the clamp on the test results could thus be lowered.



**Figure 4. Device Holder**

### 2.3.2. Phantom

Phantom for compliance testing of handheld and body-mounted wireless devices in the frequency range of 30MHz to 6 GHz. ELI is fully compatible with the IEC 62209-2 standard and all known tissue-simulating liquids. ELI has been optimized regarding its performance and can be integrated into our standard phantom tables. A cover prevents evaporation of the liquid. Reference markings on the phantom allow installation of the complete setup, including all predefined phantom positions and measurement grids, by teaching three points. The phantom is compatible with all SPEAG dosimetric probes and dipoles.

Shell Thickness	2±0.2 mm
Filling Volume	Approx. 30 liters
Dimensions	190×600×0 mm (H x L x W)



Figure 5. ELI4 Phantom

### 2.4. Scanning Procedure

The DASYS installation includes predefined files with recommended procedures for measurements and validation. They are read-only document files and destined as fully defined but unmeasured masks. All test positions (head or body-worn) are tested with the same configuration of test steps differing only in the grid definition for the different test positions.

- The “reference” and “drift” measurements are located at the beginning and end of the batch process. They measure the field drift at one single point in the liquid over the complete procedure. The indicated drift is mainly the variation of the DUT’s output power and should vary max. ± 5 %.
- The “surface check” measurement tests the optical surface detection system of the DASYS system by repeatedly detecting the surface with the optical and mechanical surface detector and comparing the results. The output gives the detecting heights of both systems, the difference between the two systems and the standard deviation of the detection repeatability. Air bubbles or refraction in the liquid due to separation of the sugar-water mixture gives poor repeatability (above ± 0.1mm). To prevent wrong results tests are only executed when the liquid is free of air bubbles. The difference between the optical surface detection and the actual surface depends on the probe and is specified with each probe. (It does not depend on the surface reflectivity or the probe angle to the surface within ± 30°.)

- Area Scan

The Area Scan is used as a fast scan in two dimensions to find the area of high field values before running a detailed measurement around the hot spot. Before starting the area scan a grid spacing of 15 mm x 15 mm is set. During the scan the distance of the probe to the phantom remains unchanged.

After finishing area scan, the field maxima within a range of 2 dB will be ascertained.

- Zoom Scan

Zoom Scans are used to estimate the peak spatial SAR values within a cubic averaging volume containing 1 g and 10 g of simulated tissue. The default Zoom Scan is done by 7x7x7 points within a cube whose base is centered around the maxima found in the preceding area scan.

- Spatial Peak Detection

The procedure for spatial peak SAR evaluation has been implemented and can determine values of masses of 1g and 10g, as well as for user-specific masses. The DASY5 system allows evaluations that combine measured data and robot positions, such as:

- maximum search
- extrapolation
- boundary correction
- peak search for averaged SAR

During a maximum search, global and local maxima searches are automatically performed in 2-D after each Area Scan measurement with at least 6 measurement points. It is based on the evaluation of the local SAR gradient calculated by the Quadratic Shepard's method. The algorithm will find the global maximum and all local maxima within -2 dB of the global maxima for all SAR distributions.

Extrapolation routines are used to obtain SAR values between the lowest measurement points and the inner phantom surface. The extrapolation distance is determined by the surface detection distance and the probe sensor offset. Several measurements at different distances are necessary for the extrapolation. Extrapolation routines require at least 10 measurement points in 3-D space. They are used in the Zoom Scan to obtain SAR values between the lowest measurement points and the inner phantom surface. The routine uses the modified Quadratic Shepard's method for extrapolation. For a grid using 7x7x7 measurement points with 5mm resolution amounting to 343 measurement points, the uncertainty of the extrapolation routines is less than 1% for 1g and 10g cubes.

- A Z-axis scan measures the total SAR value at the x-and y-position of the maximum SAR value found during the cube 7x7x7 scan. The probe is moved away in z-direction from the bottom of the SAM phantom in 5mm steps.

## **2.5. Data Storage and Evaluation**

### **2.5.1. Data Storage**

The DASY5 software stores the acquired data from the data acquisition electronics as raw data (in microvolt readings from the probe sensors), together with all necessary software parameters for the data evaluation (probe calibration data, liquid parameters and device frequency and modulation data) in measurement files with the extension “.DA4”. The software evaluates the desired unit and format for output each time the data is visualized or exported. This allows verification of the complete software setup even after the measurement and allows correction of incorrect parameter settings. For example, if a measurement has been performed with a wrong crest factor parameter in the device setup, the parameter can be corrected afterwards and the data can be re-evaluated.

The measured data can be visualized or exported in different units or formats, depending on the selected probe type ([V/m], [A/m], [°C], [mW/g], [mW/cm<sup>2</sup>], [dBrel], etc.). Some of these units are not available in certain situations or show meaningless results, e.g., a SAR output in a lossless media will always be zero. Raw data can also be exported to perform the evaluation with other software packages.

### **2.5.2. Data Evaluation by SEMCAD**

The SEMCAD software automatically executes the following procedures to calculate the field units from the microvolt readings at the probe connector. The parameters used in the evaluation are stored in the configuration modules of the software:

Probe parameters:	- Sensitivity	Normi, a <sub>i0</sub> , a <sub>i1</sub> , a <sub>i2</sub>
	- Conversion factor	ConvF <sub>i</sub>
	- Diode compression point	Dcp <sub>i</sub>
Device parameters:	- Frequency	f
	- Crest factor	cf
Media parameters:	- Conductivity	σ
	- Density	ρ

These parameters must be set correctly in the software. They can be found in the component documents or they can be imported into the software from the configuration files issued for the DASY5 components. In the direct measuring mode of the multimeter option, the parameters of the actual system setup are used. In the scan visualization and export modes, the parameters stored in the corresponding document files are used.

The first step of the evaluation is a linearization of the filtered input signal to account for the compression characteristics of the detector diode. The compensation depends on the input signal, the diode type and the DC-transmission factor from the diode to the evaluation electronics.

If the exciting field is pulsed, the crest factor of the signal must be known to correctly compensate for peak power. The formula for each channel can be given as:

$$V_i = U_i + U_i^2 \cdot c f / d c p_i$$

With  $V_i$  = compensated signal of channel i (i = x, y, z)

$U_i$  = input signal of channel i (i = x, y, z)

$cf$  = crest factor of exciting field (DASY parameter)

$dcp_i$  = diode compression point (DASY parameter)

From the compensated input signals the primary field data for each channel can be evaluated:

E-field probes:  $E_i = (V_i / Norm_i \cdot ConvF)^{1/2}$

H-field probes:  $H_i = (V_i)^{1/2} \cdot (a_{i0} + a_{i1} f + a_{i2} f^2) / f$

With  $V_i$  = compensated signal of channel i (i = x, y, z)

$Norm_i$  = sensor sensitivity of channel i (i = x, y, z)  
[mV/(V/m)<sup>2</sup>] for E-field Probes

$ConvF$  = sensitivity enhancement in solution

$a_{ij}$  = sensor sensitivity factors for H-field probes

$f$  = carrier frequency [GHz]

$E_i$  = electric field strength of channel i in V/m

$H_i$  = magnetic field strength of channel i in A/m

The RSS value of the field components gives the total field strength (Hermitian magnitude):

$$E_{tot} = (E_x^2 + E_y^2 + E_z^2)^{1/2}$$

The primary field data are used to calculate the derived field units.

$$SAR = (E_{tot}^2 \cdot \sigma) / (\rho \cdot 1000)$$



with **SAR** = local specific absorption rate in mW/g

**$E_{tot}$**  = total field strength in V/m

**$\sigma$**  = conductivity in [mho/m] or [Siemens/m]

**$\rho$**  = equivalent tissue density in g/cm<sup>3</sup>

Note that the density is normally set to 1 (or 1.06), to account for actual brain density rather than the density of the simulation liquid. The power flow density is calculated assuming the excitation field to be a free space field.

$$P_{pwe} = E_{tot}^2 / 3770 \quad \text{or} \quad P_{pwe} = H_{tot}^2 \cdot 37.7$$

with  **$P_{pwe}$**  = equivalent power density of a plane wave in mW/cm<sup>2</sup>

**$E_{tot}$**  = total electric field strength in V/m

**$H_{tot}$**  = total magnetic field strength in A/m

### 3. Laboratory Environment

**Table 1: The Requirements of the Ambient Conditions**

Temperature	Min. = 20°C, Max. = 25 °C
Relative humidity	Min. = 30%, Max. = 70%
Ground system resistance	< 0.5 $\Omega$
Ambient noise is checked and found very low and in compliance with requirement of standards.	
Reflection of surrounding objects is minimized and in compliance with requirement of standards.	

## 4. Tissue-equivalent Liquid

### 4.1. Tissue-equivalent Liquid Ingredients

The liquid is consisted of water, sugar, salt, Preventol and Cellulose. The liquid has previously been proven to be suited for worst-case. The Table 2 and Table 3 show the detail solution. It's satisfying the latest tissue dielectric parameters requirements proposed by the OET 65.

**Table 2: Composition of the Head Tissue Equivalent Matter**

MIXTURE%	FREQUENCY(Brain) 835MHz
Water	41.45
Sugar	56
Salt	1.45
Preventol	0.1
Cellulose	1.0
Dielectric Parameters Target Value	f=835MHz $\epsilon=41.5$ $\sigma=0.9$

**Table 3: Composition of the Body Tissue Equivalent Matter**

MIXTURE%	FREQUENCY(Body) 835MHz
Water	52.5
Sugar	45
Salt	1.4
Preventol	0.1
Cellulose	1.0
Dielectric Parameters Target Value	f=835MHz $\epsilon=55.2$ $\sigma=0.97$

**TA Technology (Shanghai) Co., Ltd.**  
**Test Report**

**4.2. Tissue-equivalent Liquid Properties**

**Table 4: Dielectric Performance of Head Tissue Simulating Liquid**

Frequency	Description	Dielectric Parameters		Temp ℃
		$\epsilon_r$	$\sigma(\text{s/m})$	
<b>835MHz (head)</b>	Target value ±5% window	41.50 39.43 — 43.58	0.90 0.86 — 0.95	22.0
	Measurement value 2012-3-19	43.16	0.90	21.6

**Table 5: Dielectric Performance of Body Tissue Simulating Liquid**

Frequency	Description	Dielectric Parameters		Temp ℃
		$\epsilon_r$	$\sigma(\text{s/m})$	
<b>835MHz (body)</b>	Target value ±5% window	55.20 52.44 — 57.96	0.97 0.92 — 1.02	22.0
	Measurement value 2012-3-19	54.26	0.99	21.5

## 5. System Check

### 5.1. Description of System Check

The manufacturer calibrates the probes annually. Dielectric parameters of the tissue simulants were measured every day using the dielectric probe kit and the network analyser. A system check measurement was made following the determination of the dielectric parameters of the simulant, using the dipole validation kit. A power level of 250 mW was supplied to the dipole antenna, which was placed under the flat section of the twin SAM phantom. The system check results (dielectric parameters and SAR values) are given in the table 6 and table 7.

System check results have to be equal or near the values determined during dipole calibration with the relevant liquids and test system ( $\pm 10\%$ ).

System check is performed regularly on all frequency bands where tests are performed with the DASY5 system.

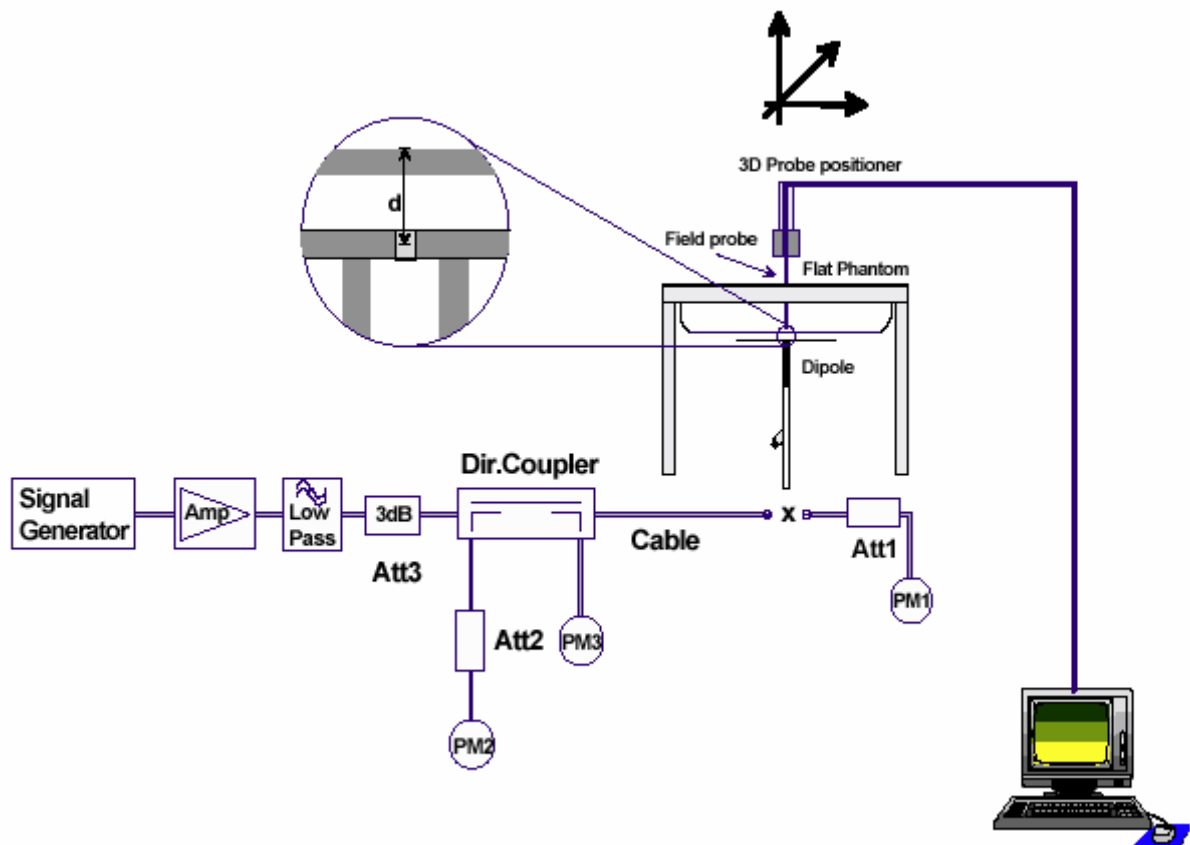

Figure 6. System Check Set-up

**TA Technology (Shanghai) Co., Ltd.**  
**Test Report**

**5.2. System Check Results**

**Table 6: System Check for Head Tissue Simulating Liquid**

Frequency	Test Date	Dielectric Parameters		Temp	250mW Measured SAR <sub>1g</sub>	1W Normalized SAR <sub>1g</sub>	1W Target SAR <sub>1g</sub> (±10% Deviation)
		$\epsilon_r$	$\sigma$ (s/m)	(°C)	(W/kg)		
835MHz	2012-3-19	43.16	0.90	21.6	2.40	9.60	9.34 (8.41~10.27)

Note: 1. The graph results see ANNEX B.  
2. Target Value used derive from the calibration certificate

**Table 7: System Check for Body Tissue Simulating Liquid**

Frequency	Test Date	Dielectric Parameters		Temp	250mW Measured SAR <sub>1g</sub>	1W Normalized SAR <sub>1g</sub>	1W Target SAR <sub>1g</sub> (±10% Deviation)
		$\epsilon_r$	$\sigma$ (s/m)	(°C)	(W/kg)		
835MHz	2012-3-19	54.26	0.99	21.5	2.54	10.16	9.46 (8.51~10.41)

Note: 1. The graph results see ANNEX B.  
2. Target Value used derive from the calibration certificate

## **6. Operational Conditions during Test**

### **6.1. General Description of Test Procedures**

The spatial peak SAR values were assessed for UHF (806.5MHz, 824.5MHz, 851.5MHz, 869.5MHz, 899MHz and 938MHz) systems. Batterys and accessories shall be specified by the manufacturer. The EUT batterys must be fully charged and checked periodically during the test to ascertain uniform power output.

### **6.2. Test Configuration**

#### **6.2.1. Face-Held Configuration**

Face-held Configuration - Default Battery Selection - per FCC KDB 643646, Page 2, Section 1) A): “When multiple standard batteries are supplied with a radio, the battery with the highest capacity is considered the default battery for making head SAR measurements.”

#### **6.2.2. Body-Worn Configuration**

a. Body-worn Configuration - Default Battery Selection - per FCC KDB 643646, Page 5, Section 1) A): Start by testing a PTT radio with the thinnest battery and a standard (default) Body-worn accessory.

b. Body-worn Configuration - Default Body-worn Accessory Selection - the belt-clip was selected as the default Body-worn accessory based on the smaller separation distance it provides between the radio and the user in comparison to the remaining accessories. Per FCC KDB 643646, Page 5, Section 1) A): “When multiple default Body-worn accessories are supplied with a radio, the standard Body-worn accessory expected to result in the highest SAR based on its construction and exposure conditions is considered the default Body-worn accessory for making Body-worn measurements.”

c. Body-worn Configuration - Additional Body-worn Accessories - the remaining Body-worn accessories were evaluated based on the “additional Body-worn accessory” guidance provided in FCC KDB 643646, Page 7, Section 4). The remaining Body-worn accessories can be utilized with all the audio accessory options.

d. Body-worn Configuration - Selection of Default Audio Accessories by Category - the Default Audio Accessories by Category were selected based on the guidance provided in FCC KDB 643646, Section “Body SAR Test Considerations for Audio Accessories without Built-in Antenna”, Page 10: “For audio accessories with similar construction and operating requirements, test only the audio accessory within the group that is expected to result in the highest SAR, with respect to changes in RF characteristics and exposure conditions for the combination. If it is unclear which audio accessory within a group of similar accessories is expected to result in the highest SAR, good engineering judgment and preliminary testing should be applied to select the accessory that is expected to result in the highest SAR.” The Remaining Audio Accessories by Category were evaluated on the highest SAR channel from the Default Audio Accessory evaluations.

## 7. Test Results

### 7.1. Conducted Power Results

**Table 8: Conducted Power Measurement Results**

<b>Analog UHF (12.5KHz)</b>	<b>Conducted Power</b>					
	806.5MHz	824.5MHz	851.5MHz	869.5MHz	899MHz	938MHz
Test Result (dBm)	34.80	34.80	34.85	34.81	34.83	34.82
<b>Digital UHF</b>	<b>Conducted Power</b>					
	806.5MHz	824.5MHz	851.5MHz	869.5MHz	899MHz	938MHz
Test Result (dBm)	34.8	34.8	34.8	34.8	34.8	34.8

**TA Technology (Shanghai) Co., Ltd.**  
**Test Report**

**7.2. SAR Test Results**

**7.2.1. UHF**

**Table 9: SAR Values (UHF)**

Limits	1 g Average (W/kg)		Power Drift (dB)	Graph Results
	8.0		± 0.21	
Frequency	Duty Cycle		Power Drift (dB)	
	100%	50%		
<b>The EUT display towards phantom for 12.5 KHz with Thicker Battery (Analog, Face Held)</b>				
851.5MHz	3.030	1.515	-0.058	Figure 9
<b>Worst case position with Thinner Battery (Analog, Face Held)</b>				
851.5MHz	3.040	1.52	-0.022	Figure 10
<b>The EUT display towards ground for 12.5 KHz with Thinner Battery, Belt and Accessory 1 (Analog, Body-Worn)</b>				
806.5MHz	3.980	1.99	-0.066	Figure 11
824.5MHz	5.330	2.665	-0.044	Figure 12
851.5MHz	8.010	4.005	-0.013	Figure 13
869.5MHz	4.590(max.cube)	2.295(max.cube)	-0.006	Figure 14
899MHz	3.590(max.cube)	1.795(max.cube)	-0.061	Figure 15
938MHz	2.540(max.cube)	1.27(max.cube)	-0.015	Figure 16
<b>The EUT display towards ground for 12.5 KHz with Thinner Battery, Belt, Accessory 1 and Earphone 1 (Analog, Body-Worn)</b>				
851.5MHz	7.080	3.54	-0.085	Figure 17
<b>The EUT display towards ground for 12.5 KHz with Thinner Battery, Belt, Accessory 1 and Earphone 2 (Analog, Body-Worn)</b>				
851.5MHz	7.720	3.86	-0.070	Figure 18
<b>The EUT display towards ground for 12.5 KHz with Thinner Battery, Belt and Audio Accessory 2 (Analog, Body-Worn)</b>				
851.5MHz	6(max.cube)	3(max.cube)	-0.031	Figure 19
<b>The EUT display towards ground for 12.5 KHz with Thinner Battery, Belt and Audio Accessory 3 (Analog, Body-Worn)</b>				
851.5MHz	5.500(max.cube)	2.75(max.cube)	-0.046	Figure 20
<b>The EUT display towards ground for 12.5 KHz with Thinner Battery, Belt and Audio Accessory 4 (Analog, Body-Worn)</b>				
851.5MHz	6.590	3.295	-0.051	Figure 21
<b>The EUT display towards ground for 12.5 KHz with Thinner Battery, Belt and Audio Accessory 5 (Analog, Body-Worn)</b>				



**TA Technology (Shanghai) Co., Ltd.**  
**Test Report**

Report No. RZA1203-0346SAR

Page 25 of 98

851.5MHz	6.120(max.cube)	3.060(max.cube)	-0.002	Figure 22
<b>The EUT display towards ground for 12.5 KHz with Thinner Battery, Pocket and Accessory 1 (Analog, Body-Worn)</b>				
851.5MHz	5.62(max.cube)	2.81(max.cube)	-0.018	Figure 23
<b>The EUT display towards ground for 12.5 KHz with Thinner Battery, Pocket, Leather and Accessory 1 (Analog, Body-Worn)</b>				
851.5MHz	3.92	1.96	-0.030	Figure 24
<b>Worst case position of Analog for Digital with Thinner Battery, Belt and Accessory 1 (Body-Worn)</b>				
851.5MHz	3.13(max.cube)	1.565(max.cube)	-0.069	Figure 25
<b>Worst case position with Thicker Battery, Belt and Accessory 1 (Analog, Body-Worn)</b>				
851.5MHz	7.43(max.cube)	3.715(max.cube)	-0.049	Figure 26
<p>Note: 1. For face-held configuration, battery “Thicker” was selected as the default battery (highest mAh).</p> <p>2. When the head SAR of an antenna tested on the highest output power channel with the default battery is &lt; 3.5 W/kg, testing of all other required channels is not necessary.</p> <p>3. When the SAR for all antennas tested using the default battery is &lt; 4.0 W/kg, test additional batteries using the antenna and channel configuration that resulted in the highest SAR among all antennas.</p> <p>4. For body-worn configuration, battery “Thinner” was selected as the default battery.</p> <p>5. When the body SAR of an antenna is ≤ 3.5 W/kg, testing of all other required channels is not necessary for that antenna.</p> <p>6. When the highest SAR of an antenna tested with the default battery using the default body-worn and audio accessory is &gt; 4.0 W/kg, test additional batteries with the default body-worn and audio accessory on the channel that resulted in the highest SAR for that antenna.</p> <p>7. The audio accessory Speaker Mic was selected as the default audio accessory based on preliminary evaluations resulting in the most conservative SAR of all the disclosed audio accessory options.</p> <p>8. The (max.cube) labeling indicates that during the grid scanning an additional peak was found which was within 2.0dB of the highest peak. The value of the highest cube is given in the table above; the value from the second assessed cube is given in the SAR distribution plots (See ANNEX C).</p>				

**TA Technology (Shanghai) Co., Ltd.**  
**Test Report**

**Table 10: SAR Values are scaled for the power drift**

Limits	1 g Average (W/kg)		Power Drift (dB)	+ Power Drift 10^(dB/10)	SAR 1g (W/kg) (include + power drift)	
	8.0		± 0.21		Duty Cycle	
Frequency	Duty Cycle		Power Drift(dB)		Duty Cycle	
	100%	50%			100%	50%
<b>The EUT display towards phantom for 12.5 KHz with Thicker Battery (Analog, Face Held)</b>						
851.5MHz	3.030	1.515	0.058	1.013	3.071	1.535
<b>Worst case position with Thinner Battery (Analog, Face Held)</b>						
851.5MHz	3.04	1.52	0.022	1.005	3.055	1.528
<b>The EUT display towards ground for 12.5 KHz with Thinner Battery, Belt and Accessory 1 (Analog, Body-Worn)</b>						
806.5MHz	3.980	1.99	0.066	1.015	4.041	2.020
824.5MHz	5.330	2.665	0.044	1.010	5.384	2.692
851.5MHz	8.010	4.005	0.013	1.003	8.034	4.017
869.5MHz	4.590	2.295	0.006	1.001	4.596	2.298
899MHz	3.590	1.795	0.061	1.014	3.641	1.820
938MHz	2.540	1.27	0.015	1.003	2.549	1.274
<b>The EUT display towards ground for 12.5 KHz with Thinner Battery, Belt, Accessory 1 and Earphone 1 (Analog, Body-Worn)</b>						
851.5MHz	7.080	3.54	0.085	1.020	7.220	3.610
<b>The EUT display towards ground for 12.5 KHz with Thinner Battery, Belt, Accessory 1 and Earphone 2 (Analog, Body-Worn)</b>						
851.5MHz	7.720	3.86	0.070	1.016	7.845	3.923
<b>The EUT display towards ground for 12.5 KHz with Thinner Battery, Belt and Audio Accessory 2 (Analog, Body-Worn)</b>						
851.5MHz	6	3	0.031	1.007	6.043	3.021
<b>The EUT display towards ground for 12.5 KHz with Thinner Battery, Belt and Audio Accessory 3 (Analog, Body-Worn)</b>						
851.5MHz	5.500	2.75	0.046	1.011	5.559	2.779
<b>The EUT display towards ground for 12.5 KHz with Thinner Battery, Belt and Audio Accessory 4 (Analog, Body-Worn)</b>						
851.5MHz	6.590	3.295	0.051	1.012	6.668	3.334
<b>The EUT display towards ground for 12.5 KHz with Thinner Battery, Belt and Audio Accessory 5 (Analog, Body-Worn)</b>						
851.5MHz	6.120	3.060	0.002	1.000	6.123	3.061

**TA Technology (Shanghai) Co., Ltd.**  
**Test Report**

Report No. RZA1203-0346SAR

Page 27 of 98

<b>The EUT display towards ground for 12.5 KHz with Thinner Battery, Pocket and Accessory 1 (Analog, Body-Worn)</b>						
851.5MHz	5.62	2.81	0.018	1.004	5.643	2.822
<b>The EUT display towards ground for 12.5 KHz with Thinner Battery, Pocket, Leather and Accessory 1 (Analog, Body-Worn)</b>						
851.5MHz	3.92	1.96	0.030	1.007	3.947	1.974
<b>Worst case position of Analog for Digital with Thinner Battery, Belt and Accessory 1 (Body-Worn)</b>						
851.5MHz	3.13	1.565	0.069	1.016	3.180	1.590
<b>Worst case position with Thicker Battery, Belt and Accessory 1 (Analog, Body-Worn)</b>						
851.5MHz	7.43	3.715	0.049	1.011	7.514	3.757
<p><b>Note:</b> 1. The value with blue color is the maximum SAR Value of each test band.</p> <p>2. The Exposure category about EUT: controlled environment / Occupational, so the SAR limit is 8.0 W/kg averaged over any 1 gram of tissue.</p> <p>3. The SAR levels reported are based on 50% PTT duty factor including SAR droop.</p>						

**TA Technology (Shanghai) Co., Ltd.**  
**Test Report**

Report No. RZA1203-0346SAR

Page 28 of 98

**8. Measurement Uncertainty**

No.	source	Type	Uncertainty Value (%)	Probability Distribution	k	c <sub>i</sub>	Standard uncertainty u <sub>i</sub> (%)	Degree of freedom V <sub>eff</sub> or V <sub>i</sub>
1	System repetivity	A	0.5	N	1	1	0.5	9
Measurement system								
2	-probe calibration	B	6.0	N	1	1	6.0	∞
3	-axial isotropy of the probe	B	4.7	R	$\sqrt{3}$	$\sqrt{0.5}$	1.9	∞
4	- Hemispherical isotropy of the probe	B	9.4	R	$\sqrt{3}$	$\sqrt{0.5}$	3.9	∞
6	-boundary effect	B	1.9	R	$\sqrt{3}$	1	1.1	∞
7	-probe linearity	B	4.7	R	$\sqrt{3}$	1	2.7	∞
8	- System detection limits	B	1.0	R	$\sqrt{3}$	1	0.6	∞
9	-readout Electronics	B	1.0	N	1	1	1.0	∞
10	-response time	B	0	R	$\sqrt{3}$	1	0	∞
11	-integration time	B	4.32	R	$\sqrt{3}$	1	2.5	∞
12	-noise	B	0	R	$\sqrt{3}$	1	0	∞
13	-RF Ambient Conditions	B	3	R	$\sqrt{3}$	1	1.73	∞
14	-Probe Positioner Mechanical Tolerance	B	0.4	R	$\sqrt{3}$	1	0.2	∞
15	-Probe Positioning with respect to Phantom Shell	B	2.9	R	$\sqrt{3}$	1	1.7	∞
16	-Extrapolation, interpolation and Integration Algorithms for Max. SAR Evaluation	B	3.9	R	$\sqrt{3}$	1	2.3	∞
Test sample Related								
17	-Test Sample Positioning	A	2.9	N	1	1	4.92	71
18	-Device Holder Uncertainty	A	4.1	N	1	1	4.1	5
19	-Output Power Variation - SAR drift measurement	B	5.0	R	$\sqrt{3}$	1	2.9	∞
Physical parameter								
20	-phantom	B	4.0	R	$\sqrt{3}$	1	2.3	∞

**TA Technology (Shanghai) Co., Ltd.**  
**Test Report**

Report No. RZA1203-0346SAR

Page 29 of 98

21	-liquid conductivity (deviation from target)	B	5.0	R	$\sqrt{3}$	0.64	1.8	$\infty$	
22	-liquid conductivity (measurement uncertainty)	B	2.5	N	1	0.64	1.6	9	
23	-liquid permittivity (deviation from target)	B	5.0	R	$\sqrt{3}$	0.6	1.7	$\infty$	
24	-liquid permittivity (measurement uncertainty)	B	2.5	N	1	0.6	1.5	9	
Combined standard uncertainty		$u_c = \sqrt{\sum_{i=1}^{21} c_i^2 u_i^2}$					12.16		
Expanded uncertainty (confidence interval of 95 %)		$u_e = 2u_c$		N	k=2		24.33		

**TA Technology (Shanghai) Co., Ltd.**  
**Test Report**

Report No. RZA1203-0346SAR

Page 30 of 98

## 9. Main Test Instruments

**Table 11: List of Main Instruments**

No.	Name	Type	Serial Number	Calibration Date	Valid Period
01	Network analyzer	Agilent 8753E	US37390326	September 12, 2011	One year
02	Dielectric Probe Kit	Agilent 85070E	US44020115	No Calibration Requested	
03	Power meter	Agilent E4417A	GB41291714	March 11, 2012	One year
04	Power sensor	Agilent N8481H	MY50350004	September 25, 2011	One year
05	Power sensor	E9327A	US40441622	September 24, 2011	One year
06	Signal Generator	HP 8341B	2730A00804	September 12, 2011	One year
07	Amplifier	IXA-020	0401	No Calibration Requested	
08	E-field Probe	EX3DV4	3578	June 21, 2011	One year
09	DAE	DAE4	871	November 22, 2011	One year
10	Validation Kit 835MHz	D835V2	4d020	August 26, 2011	One year
11	Dual directional coupler	778D-012	5051P	August 21, 2011	One year
12	Temperature Probe	JM222	AA1009129	March 15, 2012	One year
13	Hygrothermograph	HTC-1	TASH121602	June 21, 2011	One year

\*\*\*\*\*END OF REPORT \*\*\*\*\*

## ANNEX A: Test Layout



Picture 1: Specific Absorption Rate Test Layout



Picture 2: Liquid depth in the Flat Phantom (900MHz, 15.4cm depth)

## ANNEX B: System Check Results

### System Performance Check at 835 MHz Head TSL

DUT: Dipole 835 MHz; Type: D835V2; Serial: D835V2 - SN: 4d020

Date/Time: 3/19/2012 8:19:21 PM

Communication System: CW; Frequency: 835 MHz; Duty Cycle: 1:1

Medium parameters used:  $f = 835 \text{ MHz}$ ;  $\sigma = 0.90 \text{ mho/m}$ ;  $\epsilon_r = 43.16$ ;  $\rho = 1000 \text{ kg/m}^3$

Ambient Temperature:  $22.3 \text{ }^\circ\text{C}$       Liquid Temperature:  $21.6 \text{ }^\circ\text{C}$

Phantom section: Flat Section

DASY5 Configuration:

Probe: EX3DV4 - SN3578; ConvF(8.33, 8.33, 8.33) Calibrated: 6/21/2011;

Electronics: DAE4 Sn871; Calibrated: 11/22/2011

Phantom: ELI 4.0; Type: QDOVA001BA;

Measurement SW: DASY5, V5.2 Build 162; SEMCAD X Version 14.0 Build 59

**d=15mm, Pin=250mW/Area Scan (101x121x1):** Measurement grid: dx=15mm, dy=15mm  
Maximum value of SAR (interpolated) = 2.56 mW/g

**d=15mm, Pin=250mW/Zoom Scan (7x7x7)/Cube 0:** Measurement grid: dx=5mm, dy=5mm, dz=5mm

Reference Value = 51.1 V/m; Power Drift = -0.037 dB

Peak SAR (extrapolated) = 3.54 W/kg

**SAR(1 g) = 2.40 mW/g; SAR(10 g) = 1.58 mW/g**

Maximum value of SAR (measured) = 2.63 mW/g

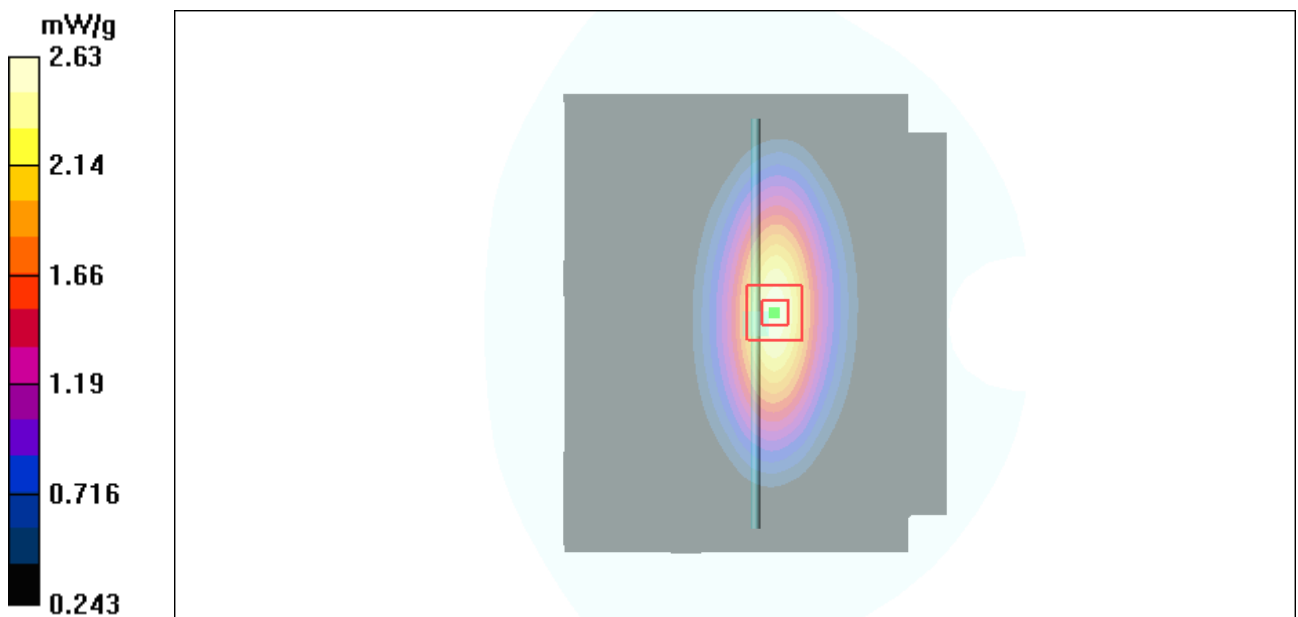

Figure 7 System Performance Check 835MHz 250mW



### System Performance Check at 835 MHz Body TSL

**DUT: Dipole 835 MHz; Type: D835V2; Serial: D835V2 - SN: 4d020**

Date/Time: 3/19/2012 10:20:21 AM

Communication System: CW; Frequency: 835 MHz; Duty Cycle: 1:1

Medium parameters used:  $f = 835 \text{ MHz}$ ;  $\sigma = 0.99 \text{ mho/m}$ ;  $\epsilon_r = 54.26$ ;  $\rho = 1000 \text{ kg/m}^3$

Ambient Temperature:  $22.3 \text{ }^\circ\text{C}$       Liquid Temperature:  $21.5 \text{ }^\circ\text{C}$

DASY5 Configuration:

Probe: EX3DV4 - SN3578; ConvF(8.45, 8.45, 8.45) Calibrated: 6/21/2011;

Electronics: DAE4 Sn871; Calibrated: 11/22/2011

Phantom: ELI 4.0; Type: QDOVA001BA;

Measurement SW: DASY5, V5.2 Build 162; SEMCAD X Version 14.0 Build 59

**d=15mm, Pin=250mW/Area Scan (61x121x1):** Measurement grid: dx=15mm, dy=15mm

Maximum value of SAR (interpolated) =  $2.72 \text{ mW/g}$

**d=15mm, Pin=250mW/Zoom Scan (7x7x7)/Cube 0:** Measurement grid: dx=5mm, dy=5mm, dz=5mm

Reference Value =  $50.9 \text{ V/m}$ ; Power Drift =  $0.023 \text{ dB}$

Peak SAR (extrapolated) =  $3.63 \text{ W/kg}$

**SAR(1 g) =  $2.54 \text{ mW/g}$ ; SAR(10 g) =  $1.64 \text{ mW/g}$**

Maximum value of SAR (measured) =  $2.72 \text{ mW/g}$

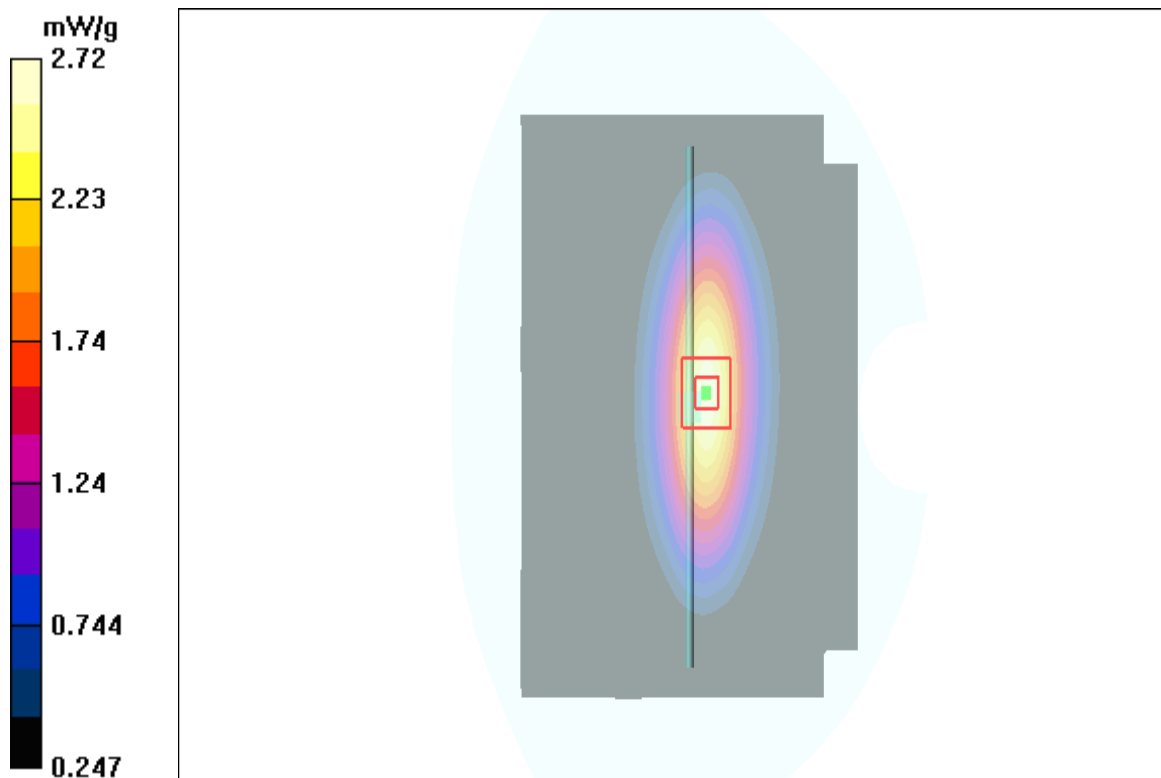

Figure 8 System Performance Check 835MHz 250mW

## ANNEX C: Graph Results

### Face Held with Thicker Battery, Front towards Phantom 851.5MHz(12.5 KHz Channel Spacing)

Date/Time: 3/19/2012 10:34:25 PM

Communication System: PTT 800; Frequency: 851.5 MHz; Duty Cycle: 1:1

Medium parameters used (interpolated):  $f = 851.5$  MHz;  $\sigma = 0.92$  mho/m;  $\epsilon_r = 43$ ;  $\rho = 1000$  kg/m<sup>3</sup>

Ambient Temperature: 22.3 °C      Liquid Temperature: 21.5°C

Phantom section: Flat Section

DASY5 Configuration:

Probe: EX3DV4 - SN3578; ConvF(8.33, 8.33, 8.33) Calibrated: 6/21/2011;

Electronics: DAE4 Sn871; Calibrated: 11/22/2011

Phantom: ELI 4.0; Type: QDOVA001BA;

Measurement SW: DASY5, V5.2 Build 162; SEMCAD X Version 14.0 Build 59

**Towards Phantom Ch 3/Area Scan (51x131x1):** Measurement grid: dx=15mm, dy=15mm

Maximum value of SAR (interpolated) = 3.27 mW/g

**Towards Phantom Ch 3/Zoom Scan (7x7x7)/Cube 0:** Measurement grid: dx=5mm, dy=5mm, dz=5mm

Reference Value = 43.6 V/m; Power Drift = -0.058 dB

Peak SAR (extrapolated) = 3.81 W/kg

**SAR(1 g) = 3.03 mW/g; SAR(10 g) = 2.26 mW/g**

Maximum value of SAR (measured) = 3.19 mW/g

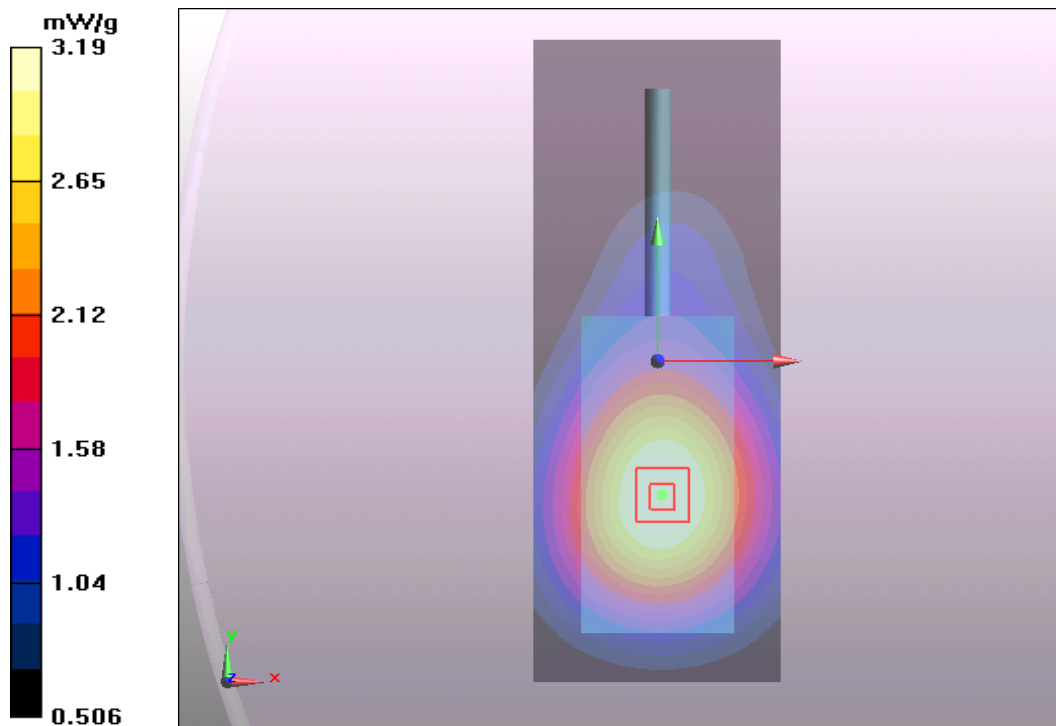

Figure 9 Face Held with Thicker Battery, Front towards Phantom 851.5MHz(12.5 KHz Channel Spacing)

# TA Technology (Shanghai) Co., Ltd. Test Report

Report No. RZA1203-0346SAR

Page 35 of 98

## Face Held with Thinner Battery, Front towards Phantom 851.5MHz(12.5 KHz Channel Spacing)

Date/Time: 3/20/2012 12:00:11 AM

Communication System: PTT 800; Frequency: 851.5 MHz; Duty Cycle: 1:1

Medium parameters used (interpolated):  $f = 851.5$  MHz;  $\sigma = 0.92$  mho/m;  $\epsilon_r = 43$ ;  $\rho = 1000$  kg/m<sup>3</sup>

Ambient Temperature: 22.3 °C      Liquid Temperature: 21.5°C

Phantom section: Flat Section

DASY5 Configuration:

Probe: EX3DV4 - SN3578; ConvF(8.33, 8.33, 8.33) Calibrated: 6/21/2011;

Electronics: DAE4 Sn871; Calibrated: 11/22/2011

Phantom: ELI 4.0; Type: QDOVA001BA;

Measurement SW: DASY5, V5.2 Build 162; SEMCAD X Version 14.0 Build 59

**Towards Phantom Ch 3/Area Scan (51x131x1):** Measurement grid: dx=15mm, dy=15mm

Maximum value of SAR (interpolated) = 3.3 mW/g

**Towards Phantom Ch 3/Zoom Scan (7x7x7)/Cube 0:** Measurement grid: dx=5mm, dy=5mm, dz=5mm

Reference Value = 42.9 V/m; Power Drift = -0.022 dB

Peak SAR (extrapolated) = 3.83 W/kg

**SAR(1 g) = 3.04 mW/g; SAR(10 g) = 2.27 mW/g**

Maximum value of SAR (measured) = 3.21 mW/g

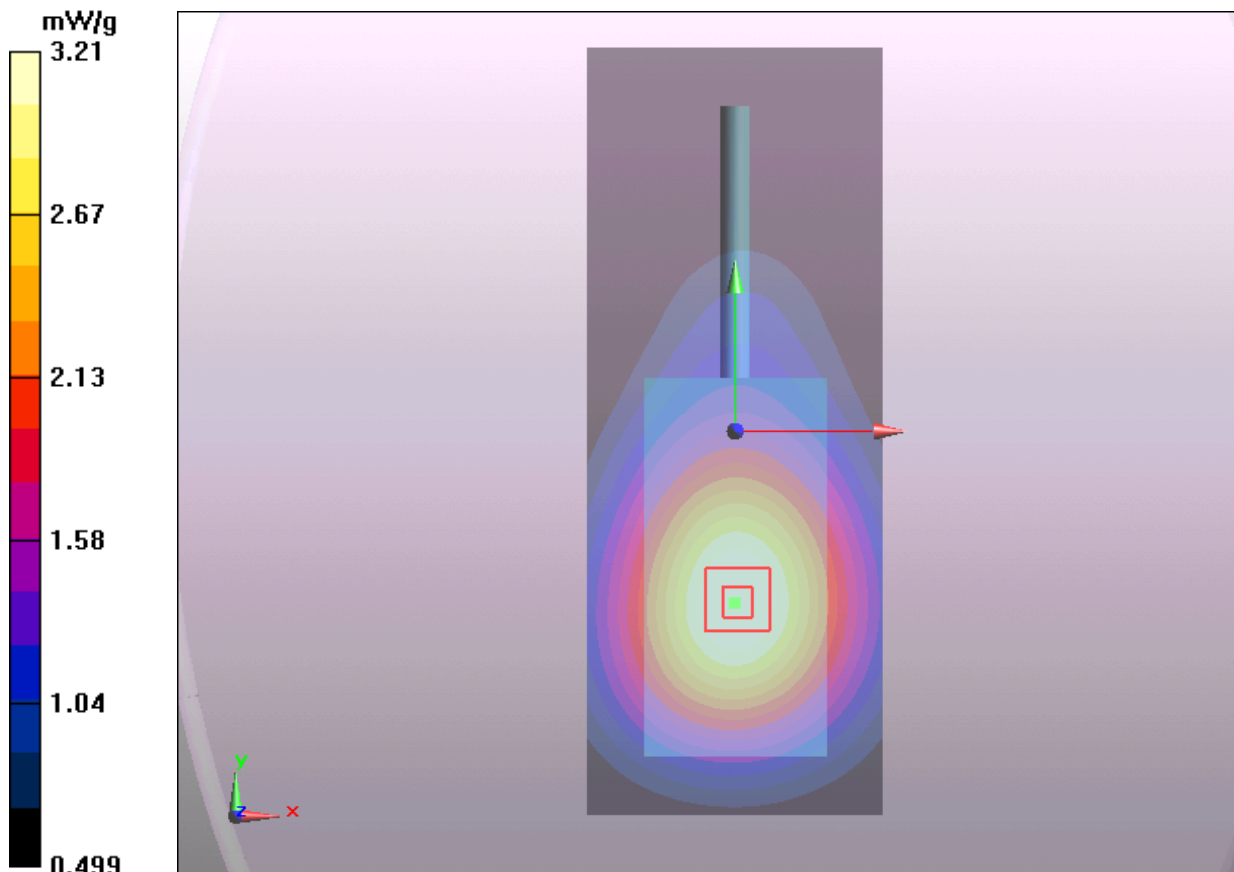

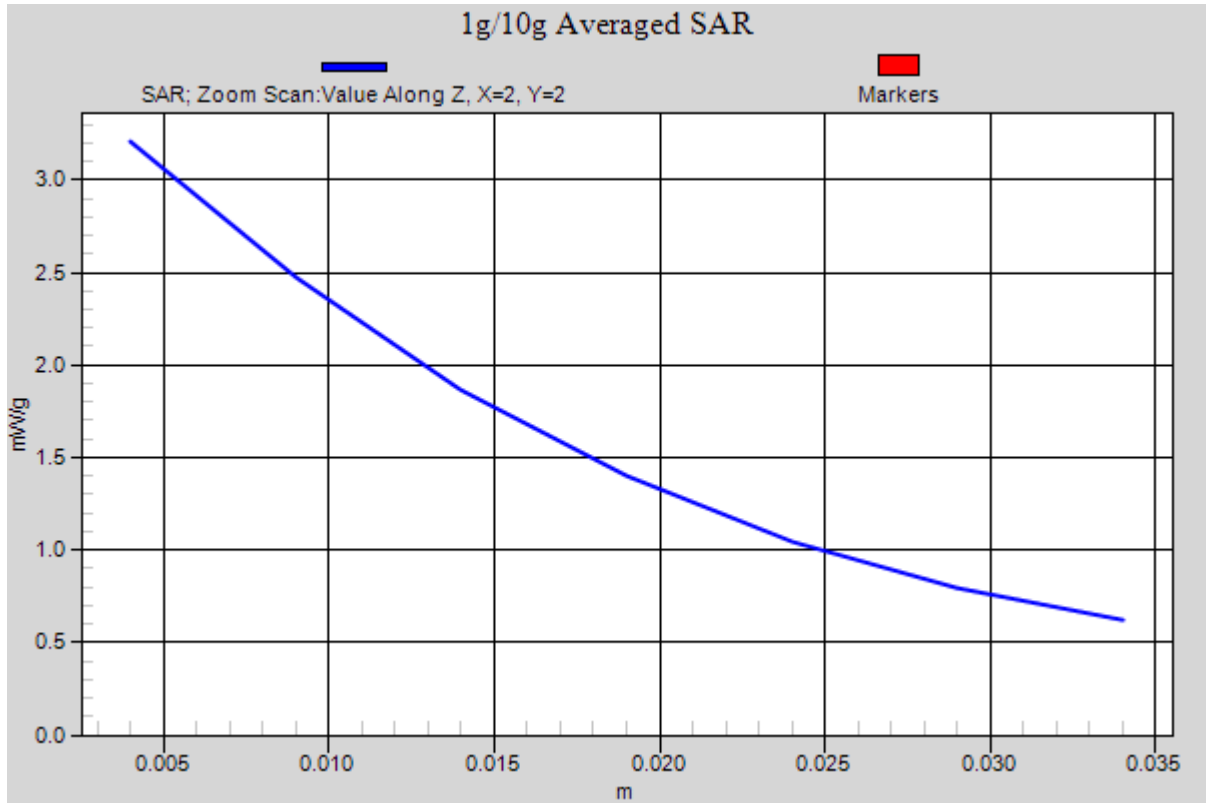

Figure 10 Face Held with Thinner Battery, Front towards Phantom 851.5MHz(12.5 KHz Channel Spacing)

**Body-Worn with Thinner Battery, Belt and Accessory 1, Front towards Ground  
806.5MHz(12.5 KHz Channel Spacing)**

Date/Time: 3/19/2012 11:56:08 AM

Communication System: PTT 800; Frequency: 806.5 MHz; Duty Cycle: 1:1

Medium parameters used (interpolated):  $f = 806.5$  MHz;  $\sigma = 0.957$  mho/m;  $\epsilon_r = 54.5$ ;  $\rho = 1000$  kg/m<sup>3</sup>

Ambient Temperature: 22.3 °C      Liquid Temperature: 21.5 °C

Phantom section: Flat Section

DASY5 Configuration:

Probe: EX3DV4 - SN3578; ConvF(8.45, 8.45, 8.45) Calibrated: 6/21/2011;

Electronics: DAE4 Sn871; Calibrated: 11/22/2011

Phantom: ELI 4.0; Type: QDOVA001BA;

Measurement SW: DASY5, V5.2 Build 162; SEMCAD X Version 14.0 Build 59

**Towards Ground Ch 1/Area Scan (51x131x1):** Measurement grid: dx=15mm, dy=15mm  
Maximum value of SAR (interpolated) = 4.27 mW/g

**Towards Ground Ch 1/Zoom Scan (7x7x7)/Cube 0:** Measurement grid: dx=5mm, dy=5mm,  
dz=5mm

Reference Value = 63.9 V/m; Power Drift = -0.066 dB

Peak SAR (extrapolated) = 4.87 W/kg

**SAR(1 g) = 3.98 mW/g; SAR(10 g) = 2.98 mW/g**

Maximum value of SAR (measured) = 4.2 mW/g

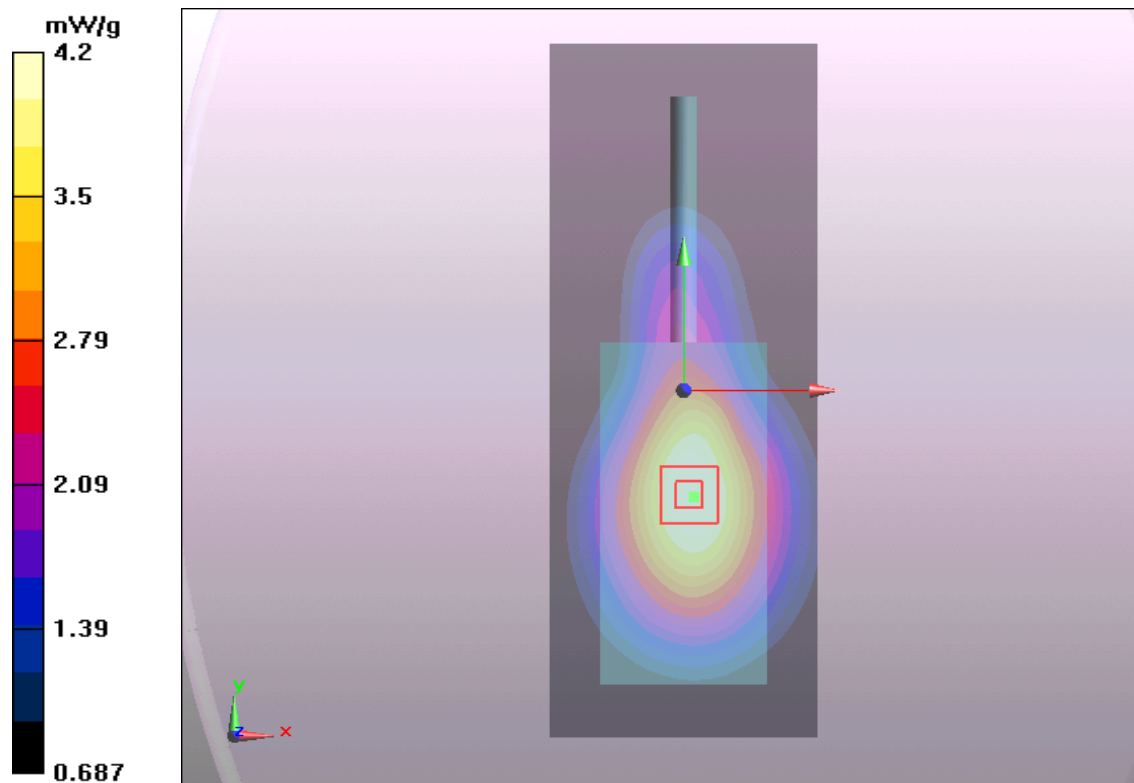

**Figure 11 Body-Worn with Thinner Battery, Belt and Accessory 1, Front towards Ground  
806.5MHz(12.5 KHz Channel Spacing)**

**Body-Worn with Thinner Battery, Belt and Accessory 1, Front towards Ground  
824.5MHz(12.5 KHz Channel Spacing)**

Date/Time: 3/19/2012 12:19:31 PM

Communication System: PTT 800; Frequency: 824.5 MHz;Duty Cycle: 1:1

Medium parameters used (interpolated):  $f = 824.5$  MHz;  $\sigma = 0.972$  mho/m;  $\epsilon_r = 54.4$ ;  $\rho = 1000$  kg/m<sup>3</sup>

Ambient Temperature:22.3 °C      Liquid Temperature: 21.5°C

Phantom section: Flat Section

DASY5 Configuration:

Probe: EX3DV4 - SN3578; ConvF(8.45, 8.45, 8.45) Calibrated: 6/21/2011;

Electronics: DAE4 Sn871; Calibrated: 11/22/2011

Phantom: ELI 4.0; Type: QDOVA001BA;

Measurement SW: DASY5, V5.2 Build 162; SEMCAD X Version 14.0 Build 59

**Towards Ground Ch 2/Area Scan (51x131x1):** Measurement grid: dx=15mm, dy=15mm  
Maximum value of SAR (interpolated) = 5.66 mW/g

**Towards Ground Ch 2/Zoom Scan (7x7x7)/Cube 0:** Measurement grid: dx=5mm, dy=5mm,  
dz=5mm

Reference Value = 71.8 V/m; Power Drift = -0.044 dB

Peak SAR (extrapolated) = 6.85 W/kg

**SAR(1 g) = 5.33 mW/g; SAR(10 g) = 3.97 mW/g**

Maximum value of SAR (measured) = 5.74 mW/g

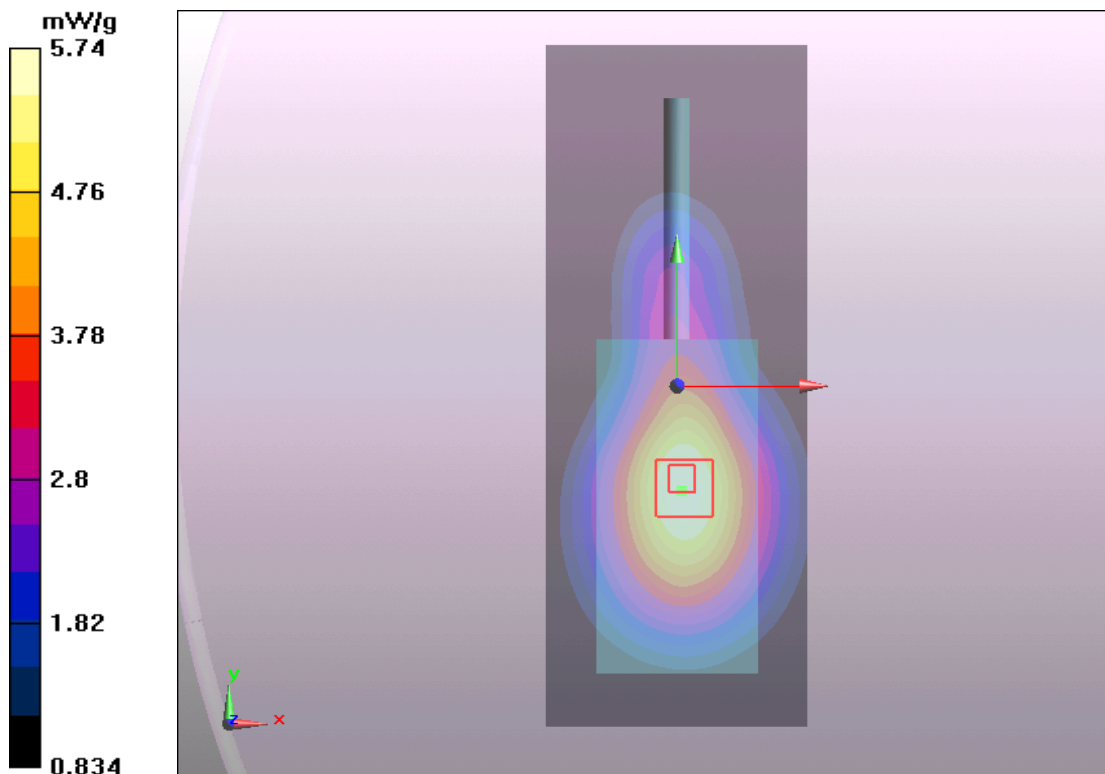

**Figure 12 Body-Worn with Thinner Battery, Belt and Accessory 1, Front towards Ground  
824.5MHz(12.5 KHz Channel Spacing)**

**Body-Worn with Thinner Battery, Belt and Accessory 1, Front towards Ground  
851.5MHz(12.5 KHz Channel Spacing)**

Date/Time: 3/19/2012 1:23:45 PM

Communication System: PTT 800; Frequency: 851.5 MHz;Duty Cycle: 1:1

Medium parameters used (interpolated):  $f = 851.5$  MHz;  $\sigma = 1.01$  mho/m;  $\epsilon_r = 54.1$ ;  $\rho = 1000$  kg/m<sup>3</sup>

Ambient Temperature:22.3 °C      Liquid Temperature: 21.5°C

Phantom section: Flat Section

DASY5 Configuration:

Probe: EX3DV4 - SN3578; ConvF(8.45, 8.45, 8.45) Calibrated: 6/21/2011;

Electronics: DAE4 Sn871; Calibrated: 11/22/2011

Phantom: ELI 4.0; Type: QDOVA001BA;

Measurement SW: DASY5, V5.2 Build 162; SEMCAD X Version 14.0 Build 59

**Towards Ground Ch 3/Area Scan (51x131x1):** Measurement grid: dx=15mm, dy=15mm  
Maximum value of SAR (interpolated) = 8.29 mW/g

**Towards Ground Ch 3/Zoom Scan (7x7x7)/Cube 0:** Measurement grid: dx=5mm, dy=5mm,  
dz=5mm

Reference Value = 78.3 V/m; Power Drift = -0.013 dB

Peak SAR (extrapolated) = 12.5 W/kg

**SAR(1 g) = 8.01 mW/g; SAR(10 g) = 5.18 mW/g**

Maximum value of SAR (measured) = 8.9 mW/g

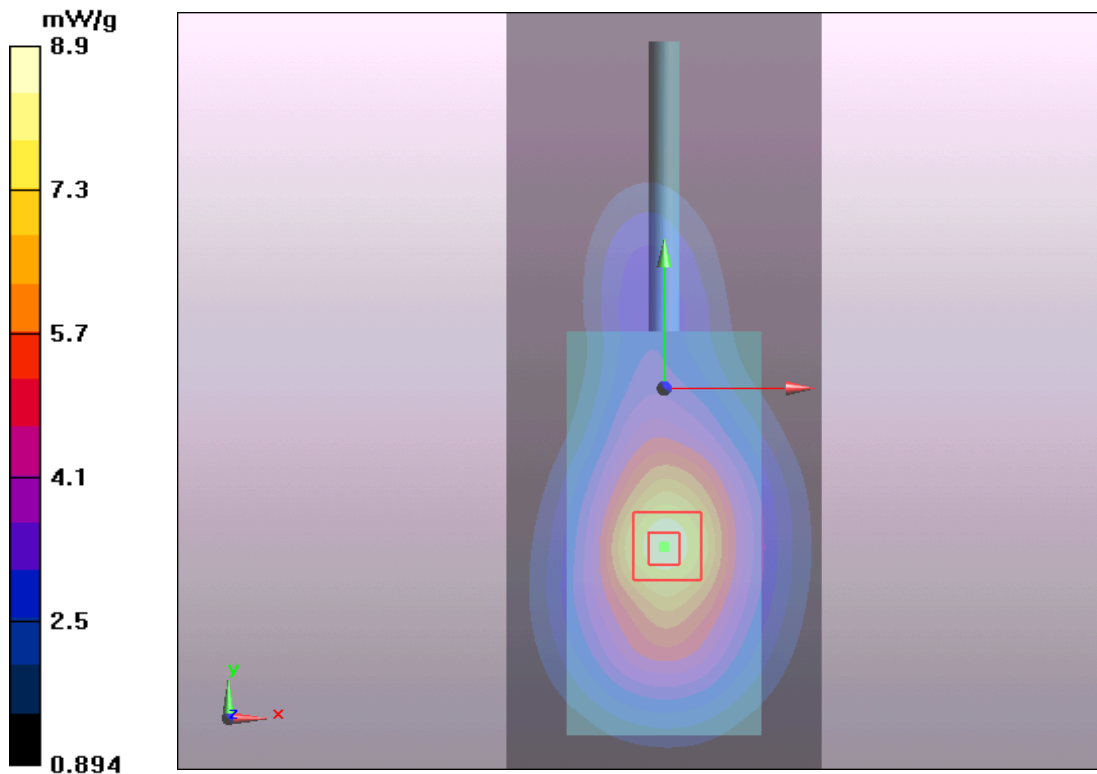

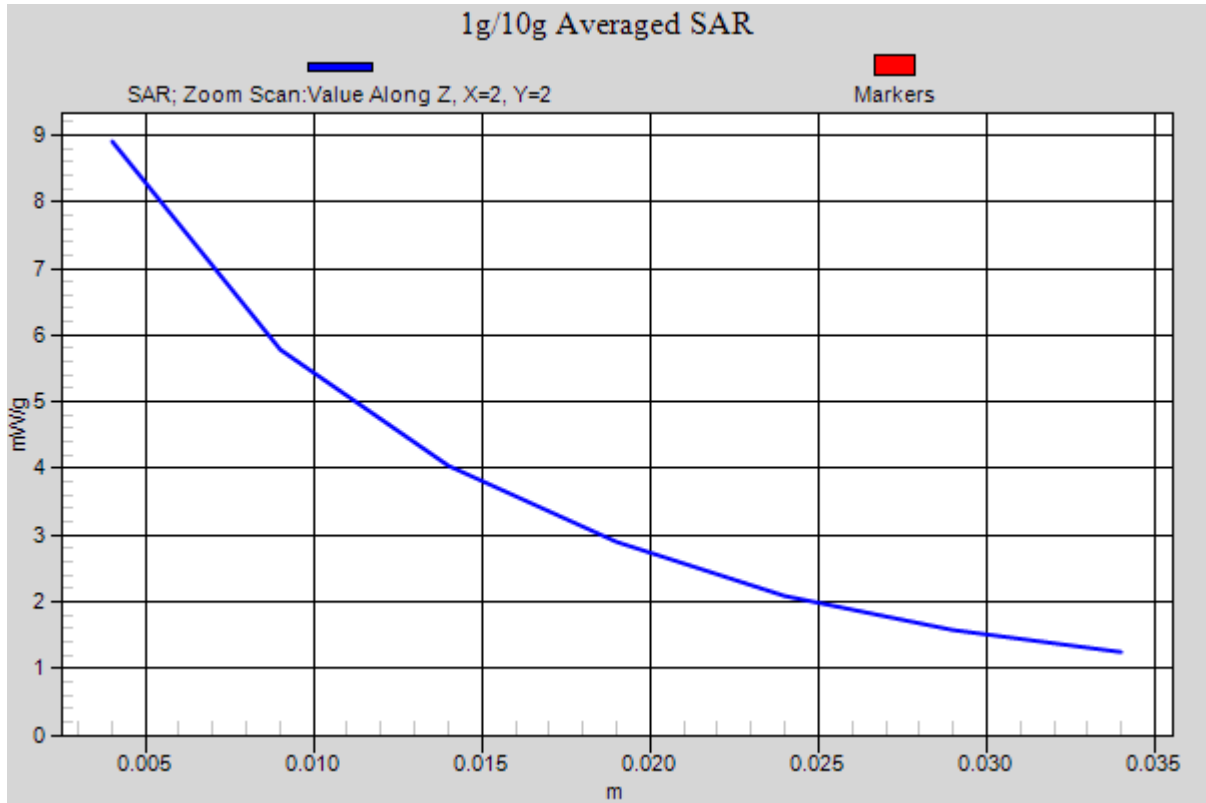

Figure 13 Body-Worn with Thinner Battery, Belt and Accessory 1, Front towards Ground  
851.5MHz(12.5 KHz Channel Spacing)



**TA Technology (Shanghai) Co., Ltd.**  
**Test Report**

**Body-Worn with Thinner Battery, Belt and Accessory 1, Front towards Ground  
869.5MHz(12.5 KHz Channel Spacing)**

Date/Time: 3/19/2012 2:31:48 PM

Communication System: PTT 800; Frequency: 869.5 MHz; Duty Cycle: 1:1

Medium parameters used (interpolated):  $f = 869.5$  MHz;  $\sigma = 1.03$  mho/m;  $\epsilon_r = 54$ ;  $\rho = 1000$  kg/m<sup>3</sup>

Ambient Temperature: 22.3 °C      Liquid Temperature: 21.5°C

Phantom section: Flat Section

DASY5 Configuration:

Probe: EX3DV4 - SN3578; ConvF(8.45, 8.45, 8.45) Calibrated: 6/21/2011;

Electronics: DAE4 Sn871; Calibrated: 11/22/2011

Phantom: ELI 4.0; Type: QDOVA001BA;

Measurement SW: DASY5, V5.2 Build 162; SEMCAD X Version 14.0 Build 59

**Towards Ground Ch 4/Area Scan (51x131x1):** Measurement grid: dx=15mm, dy=15mm

Maximum value of SAR (interpolated) = 5 mW/g

**Towards Ground Ch 4/Zoom Scan (7x7x7)/Cube 1:** Measurement grid: dx=5mm, dy=5mm, dz=5mm

Reference Value = 72.6 V/m; Power Drift = -0.006 dB

Peak SAR (extrapolated) = 5.59 W/kg

**SAR(1 g) = 3.67 mW/g; SAR(10 g) = 2.57 mW/g**

Maximum value of SAR (measured) = 4.15 mW/g

**Towards Ground Ch 4/Zoom Scan (7x7x7)/Cube 0:** Measurement grid: dx=5mm, dy=5mm, dz=5mm

Reference Value = 72.6 V/m; Power Drift = -0.006 dB

Peak SAR (extrapolated) = 5.87 W/kg

**SAR(1 g) = 4.59 mW/g; SAR(10 g) = 3.43 mW/g**

Maximum value of SAR (measured) = 4.83 mW/g

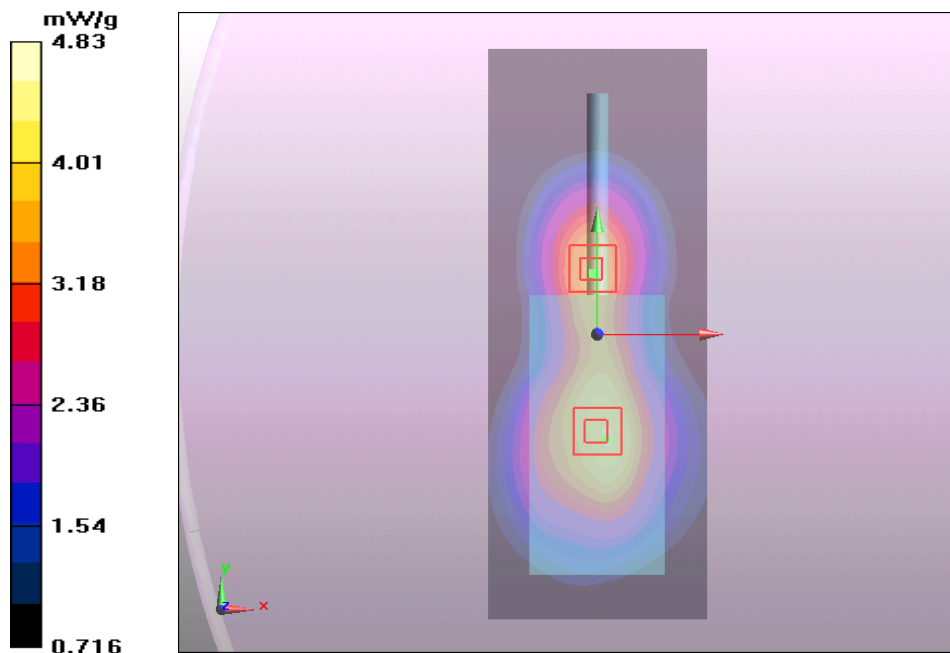

**Figure 14 Body-Worn with Thinner Battery, Belt and Accessory 1, Front towards Ground  
869.5MHz(12.5 KHz Channel Spacing)**

**Body-Worn with Thinner Battery, Belt and Accessory 1, Front towards Ground  
899MHz(12.5 KHz Channel Spacing)**

Date/Time: 3/19/2012 3:37:17 PM

Communication System: PTT 800; Frequency: 899 MHz; Duty Cycle: 1:1

Medium parameters used:  $f = 899$  MHz;  $\sigma = 1.06$  mho/m;  $\epsilon_r = 53.7$ ;  $\rho = 1000$  kg/m<sup>3</sup>

Ambient Temperature: 22.3 °C      Liquid Temperature: 21.5 °C

Phantom section: Flat Section

DASY5 Configuration:

Probe: EX3DV4 - SN3578; ConvF(8.34, 8.34, 8.34) Calibrated: 6/21/2011;

Electronics: DAE4 Sn871; Calibrated: 11/22/2011

Phantom: ELI 4.0; Type: QDOVA001BA;

Measurement SW: DASY5, V5.2 Build 162; SEMCAD X Version 14.0 Build 59

**Towards Ground Ch 5/Area Scan (51x131x1):** Measurement grid: dx=15mm, dy=15mm

Maximum value of SAR (interpolated) = 3.34 mW/g

**Towards Ground Ch 5/Zoom Scan (7x7x7)/Cube 1:** Measurement grid: dx=5mm, dy=5mm, dz=5mm

Reference Value = 64.2 V/m; Power Drift = -0.061 dB

Peak SAR (extrapolated) = 4.22 W/kg

**SAR(1 g) = 3.06 mW/g; SAR(10 g) = 2.13 mW/g**

Maximum value of SAR (measured) = 3.27 mW/g

**Towards Ground Ch 5/Zoom Scan (7x7x7)/Cube 0:** Measurement grid: dx=5mm, dy=5mm, dz=5mm

Reference Value = 64.2 V/m; Power Drift = -0.061 dB

Peak SAR (extrapolated) = 4.72 W/kg

**SAR(1 g) = 3.59 mW/g; SAR(10 g) = 2.66 mW/g**

Maximum value of SAR (measured) = 3.74 mW/g

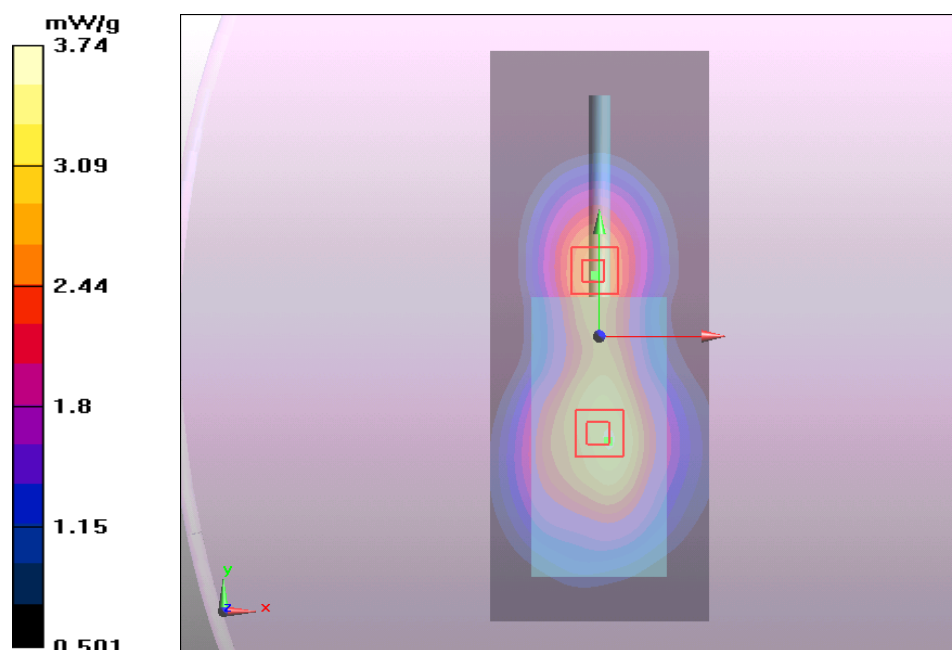

**Figure 15 Body-Worn with Thinner Battery, Belt and Accessory 1, Front towards Ground  
899MHz(12.5 KHz Channel Spacing)**

# TA Technology (Shanghai) Co., Ltd. Test Report

Report No. RZA1203-0346SAR

Page 43 of 98

## Body-Worn with Thinner Battery, Belt and Accessory 1, Front towards Ground 938MHz(12.5 KHz Channel Spacing)

Date/Time: 3/19/2012 4:04:34 PM

Communication System: PTT 800; Frequency: 938 MHz; Duty Cycle: 1:1

Medium parameters used:  $f = 938$  MHz;  $\sigma = 1.09$  mho/m;  $\epsilon_r = 53.3$ ;  $\rho = 1000$  kg/m<sup>3</sup>

Ambient Temperature: 22.3 °C      Liquid Temperature: 21.5 °C

Phantom section: Flat Section

DASY5 Configuration:

Probe: EX3DV4 - SN3578; ConvF(8.34, 8.34, 8.34) Calibrated: 6/21/2011;

Electronics: DAE4 Sn871; Calibrated: 11/22/2011

Phantom: ELI 4.0; Type: QDOVA001BA;

Measurement SW: DASY5, V5.2 Build 162; SEMCAD X Version 14.0 Build 59

**Towards Ground Ch 6/Area Scan (51x131x1):** Measurement grid: dx=15mm, dy=15mm

Maximum value of SAR (interpolated) = 2.73 mW/g

**Towards Ground Ch 6/Zoom Scan (7x7x7)/Cube 1:** Measurement grid: dx=5mm, dy=5mm, dz=5mm

Reference Value = 50.9 V/m; Power Drift = -0.015 dB

Peak SAR (extrapolated) = 3.26 W/kg

**SAR(1 g) = 2.44 mW/g; SAR(10 g) = 1.78 mW/g**

Maximum value of SAR (measured) = 2.57 mW/g

**Towards Ground Ch 6/Zoom Scan (7x7x7)/Cube 0:** Measurement grid: dx=5mm, dy=5mm, dz=5mm

Reference Value = 50.9 V/m; Power Drift = -0.015 dB

Peak SAR (extrapolated) = 3.56 W/kg

**SAR(1 g) = 2.54 mW/g; SAR(10 g) = 1.76 mW/g**

Maximum value of SAR (measured) = 2.71 mW/g

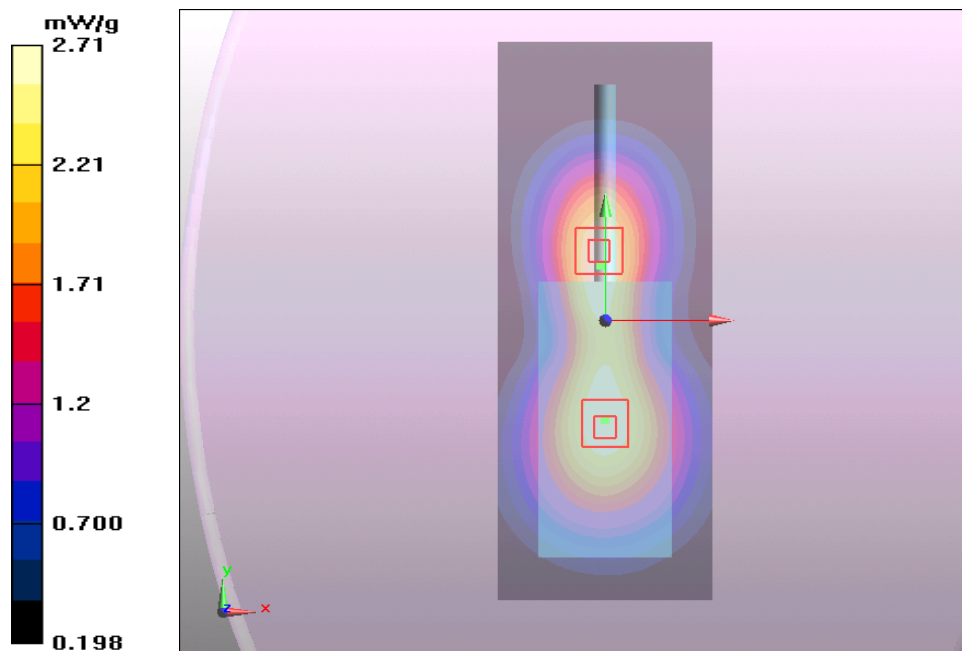

Figure 16 Body-Worn with Thinner Battery, Belt and Accessory 1, Front towards Ground  
938MHz(12.5 KHz Channel Spacing)

**TA Technology (Shanghai) Co., Ltd.**  
**Test Report**

**Body-Worn with Thinner Battery, Belt, Accessory 1 and Earphone 1, Front towards Ground 851.5MHz(12.5 KHz Channel Spacing)**

Date/Time: 3/19/2012 8:14:19 PM

Communication System: PTT 800; Frequency: 851.5 MHz; Duty Cycle: 1:1

Medium parameters used (interpolated):  $f = 851.5$  MHz;  $\sigma = 1.01$  mho/m;  $\epsilon_r = 54.1$ ;  $\rho = 1000$  kg/m<sup>3</sup>

Ambient Temperature: 22.3 °C      Liquid Temperature: 21.5°C

Phantom section: Flat Section

DASY5 Configuration:

Probe: EX3DV4 - SN3578; ConvF(8.45, 8.45, 8.45) Calibrated: 6/21/2011;

Electronics: DAE4 Sn871; Calibrated: 11/22/2011

Phantom: ELI 4.0; Type: QDOVA001BA;

Measurement SW: DASY5, V5.2 Build 162; SEMCAD X Version 14.0 Build 59

**Towards Ground Ch 3/Area Scan (51x131x1):** Measurement grid: dx=15mm, dy=15mm

Maximum value of SAR (interpolated) = 7.31 mW/g

**Towards Ground Ch 3/Zoom Scan (7x7x7)/Cube 0:** Measurement grid: dx=5mm, dy=5mm, dz=5mm

Reference Value = 71.8 V/m; Power Drift = -0.085 dB

Peak SAR (extrapolated) = 10.4 W/kg

**SAR(1 g) = 7.08 mW/g; SAR(10 g) = 4.84 mW/g**

Maximum value of SAR (measured) = 7.73 mW/g

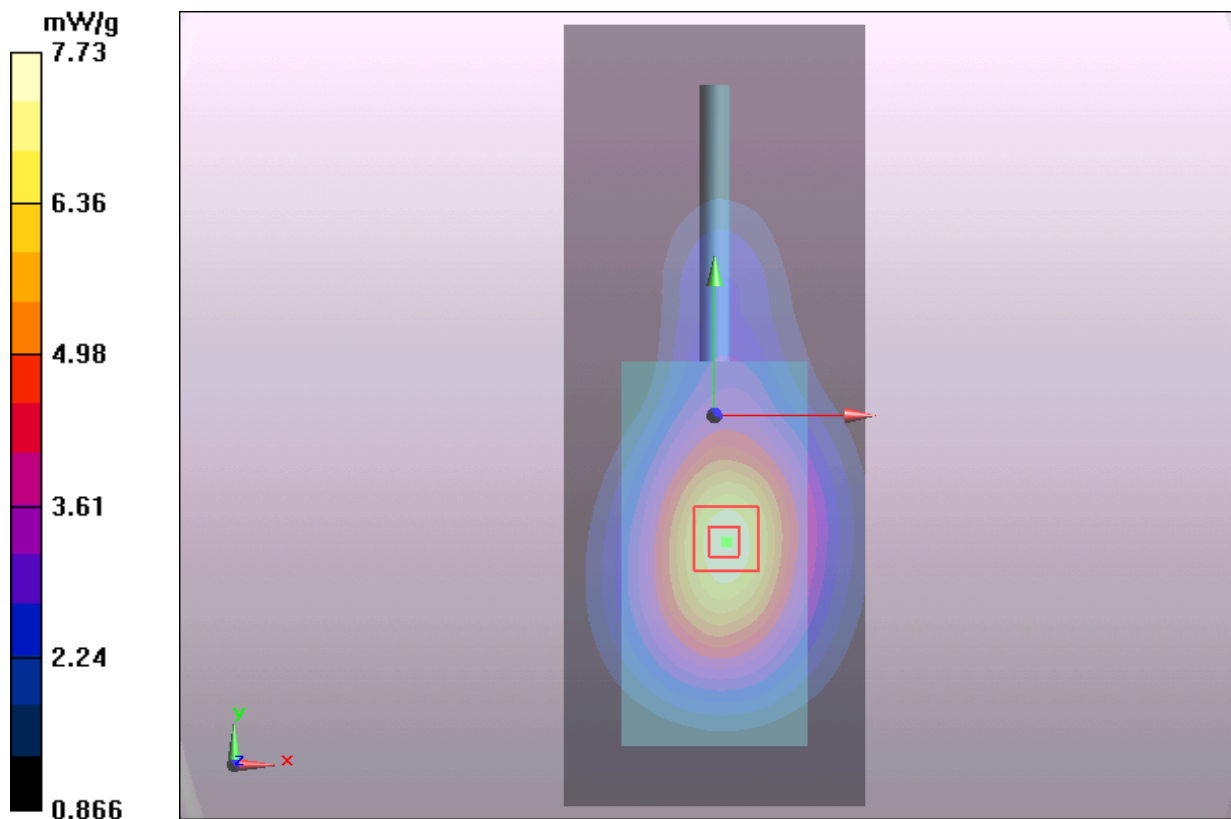

**Figure 17 Body-Worn with Thinner Battery, Belt, Accessory 1 and Earphone 1, Front towards Ground 851.5MHz(12.5 KHz Channel Spacing)**

**TA Technology (Shanghai) Co., Ltd.**  
**Test Report**

**Body-Worn with Thinner Battery, Belt, Accessory 1 and Earphone 2, Front towards Ground 851.5MHz(12.5 KHz Channel Spacing)**

Date/Time: 3/19/2012 8:52:13 PM

Communication System: PTT 800; Frequency: 851.5 MHz; Duty Cycle: 1:1

Medium parameters used (interpolated):  $f = 851.5$  MHz;  $\sigma = 1.01$  mho/m;  $\epsilon_r = 54.1$ ;  $\rho = 1000$  kg/m<sup>3</sup>

Ambient Temperature: 22.3 °C      Liquid Temperature: 21.5°C

Phantom section: Flat Section

DASY5 Configuration:

Probe: EX3DV4 - SN3578; ConvF(8.45, 8.45, 8.45) Calibrated: 6/21/2011;

Electronics: DAE4 Sn871; Calibrated: 11/22/2011

Phantom: ELI 4.0; Type: QDOVA001BA;

Measurement SW: DASY5, V5.2 Build 162; SEMCAD X Version 14.0 Build 59

**Towards Ground Ch 3/Area Scan (51x131x1):** Measurement grid: dx=15mm, dy=15mm

Maximum value of SAR (interpolated) = 9.16 mW/g

**Towards Ground Ch 3/Zoom Scan (7x7x7)/Cube 0:** Measurement grid: dx=5mm, dy=5mm, dz=5mm

Reference Value = 76 V/m; Power Drift = -0.070 dB

Peak SAR (extrapolated) = 12.1 W/kg

**SAR(1 g) = 7.72 mW/g; SAR(10 g) = 5.06 mW/g**

Maximum value of SAR (measured) = 8.44 mW/g

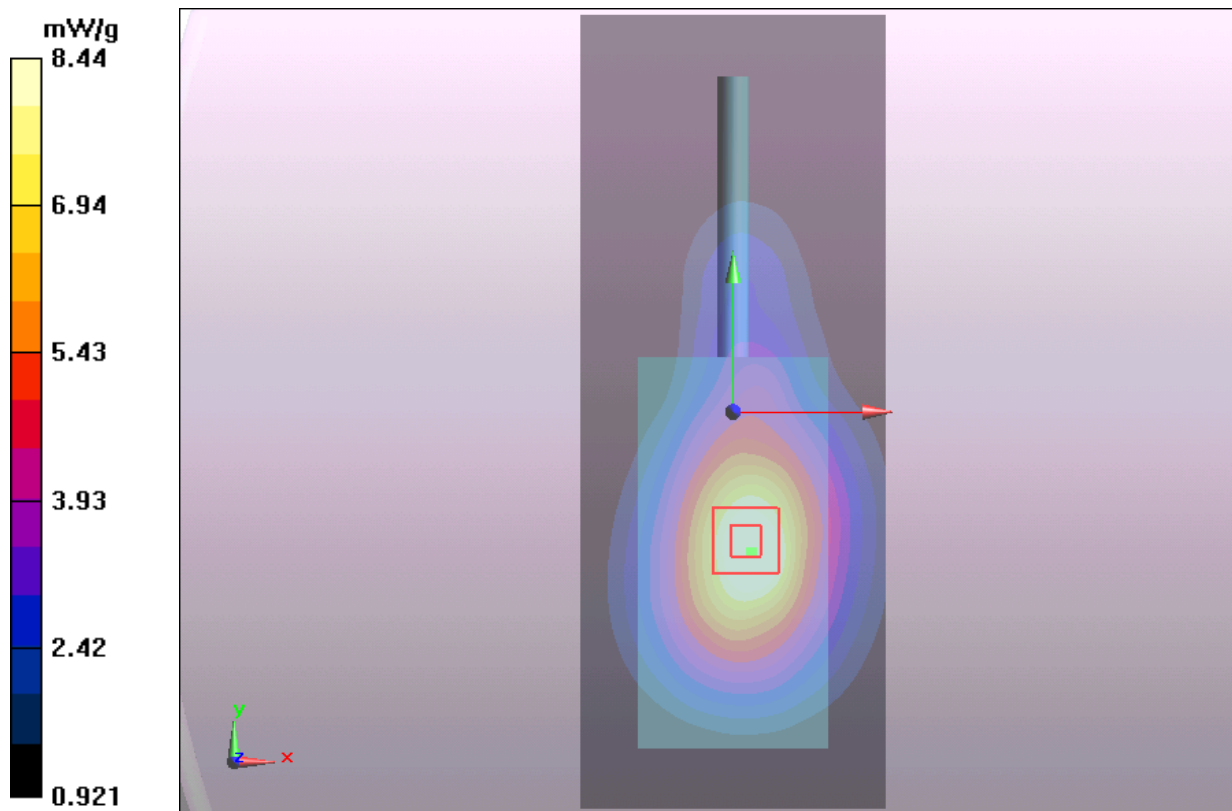

**Figure 18 Body-Worn with Thinner Battery, Belt, Accessory 1 and Earphone 2, Front towards Ground 851.5MHz(12.5 KHz Channel Spacing)**

**TA Technology (Shanghai) Co., Ltd.**  
**Test Report**

**Body-Worn with Thinner Battery, Belt and Audio Accessory 2, Front towards Ground 851.5MHz(12.5 KHz Channel Spacing)**

Date/Time: 3/19/2012 5:03:11 PM

Communication System: PTT 800; Frequency: 851.5 MHz; Duty Cycle: 1:1

Medium parameters used (interpolated):  $f = 851.5$  MHz;  $\sigma = 1.01$  mho/m;  $\epsilon_r = 54.1$ ;  $\rho = 1000$  kg/m<sup>3</sup>

Ambient Temperature: 22.3 °C      Liquid Temperature: 21.5 °C

Phantom section: Flat Section

DASY5 Configuration:

Probe: EX3DV4 - SN3578; ConvF(8.45, 8.45, 8.45) Calibrated: 6/21/2011;

Electronics: DAE4 Sn871; Calibrated: 11/22/2011

Phantom: ELI 4.0; Type: QDOVA001BA;

Measurement SW: DASY5, V5.2 Build 162; SEMCAD X Version 14.0 Build 59

**Towards Ground Ch 3/Area Scan (51x131x1):** Measurement grid: dx=15mm, dy=15mm

Maximum value of SAR (interpolated) = 6.5 mW/g

**Towards Ground Ch 3/Zoom Scan (7x7x7)/Cube 1:** Measurement grid: dx=5mm, dy=5mm, dz=5mm

Reference Value = 77.8 V/m; Power Drift = -0.031 dB

Peak SAR (extrapolated) = 5.59 W/kg

**SAR(1 g) = 3.82 mW/g; SAR(10 g) = 2.68 mW/g**

Maximum value of SAR (measured) = 4.22 mW/g

**Towards Ground Ch 3/Zoom Scan (7x7x7)/Cube 0:** Measurement grid: dx=5mm, dy=5mm, dz=5mm

Reference Value = 77.8 V/m; Power Drift = -0.031 dB

Peak SAR (extrapolated) = 7.55 W/kg

**SAR(1 g) = 6 mW/g; SAR(10 g) = 4.49 mW/g**

Maximum value of SAR (measured) = 6.32 mW/g

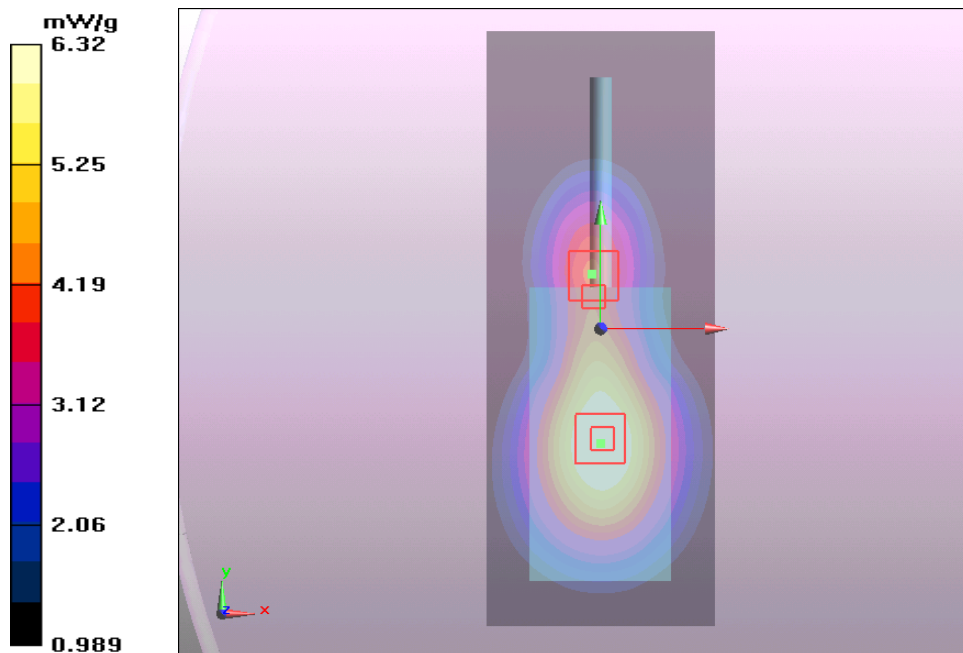

**Figure 19 Body-Worn with Thinner Battery, Belt and Audio Accessory 2, Front towards Ground 851.5MHz(12.5 KHz Channel Spacing)**

**TA Technology (Shanghai) Co., Ltd.**  
**Test Report**

Report No. RZA1203-0346SAR

Page 47 of 98

**Body-Worn with Thinner Battery, Belt and Audio Accessory 3, Front towards Ground 851.5MHz(12.5 KHz Channel Spacing)**

Date/Time: 3/19/2012 5:35:11 PM

Communication System: PTT 800; Frequency: 851.5 MHz; Duty Cycle: 1:1

Medium parameters used (interpolated):  $f = 851.5$  MHz;  $\sigma = 1.01$  mho/m;  $\epsilon_r = 54.1$ ;  $\rho = 1000$  kg/m<sup>3</sup>

Ambient Temperature: 22.3 °C      Liquid Temperature: 21.5°C

Phantom section: Flat Section

DASY5 Configuration:

Probe: EX3DV4 - SN3578; ConvF(8.45, 8.45, 8.45) Calibrated: 6/21/2011;

Electronics: DAE4 Sn871; Calibrated: 11/22/2011

Phantom: ELI 4.0; Type: QDOVA001BA;

Measurement SW: DASY5, V5.2 Build 162; SEMCAD X Version 14.0 Build 59

**Towards Ground Ch 3/Area Scan (51x131x1):** Measurement grid: dx=15mm, dy=15mm

Maximum value of SAR (interpolated) = 5.96 mW/g

**Towards Ground Ch 3/Zoom Scan (7x7x7)/Cube 1:** Measurement grid: dx=5mm, dy=5mm, dz=5mm

Reference Value = 74.2 V/m; Power Drift = -0.046 dB

Peak SAR (extrapolated) = 5.02 W/kg

**SAR(1 g) = 3.62 mW/g; SAR(10 g) = 2.56 mW/g**

Maximum value of SAR (measured) = 3.94 mW/g

**Towards Ground Ch 3/Zoom Scan (7x7x7)/Cube 0:** Measurement grid: dx=5mm, dy=5mm, dz=5mm

Reference Value = 74.2 V/m; Power Drift = -0.046 dB

Peak SAR (extrapolated) = 6.9 W/kg

**SAR(1 g) = 5.5 mW/g; SAR(10 g) = 4.12 mW/g**

Maximum value of SAR (measured) = 5.78 mW/g

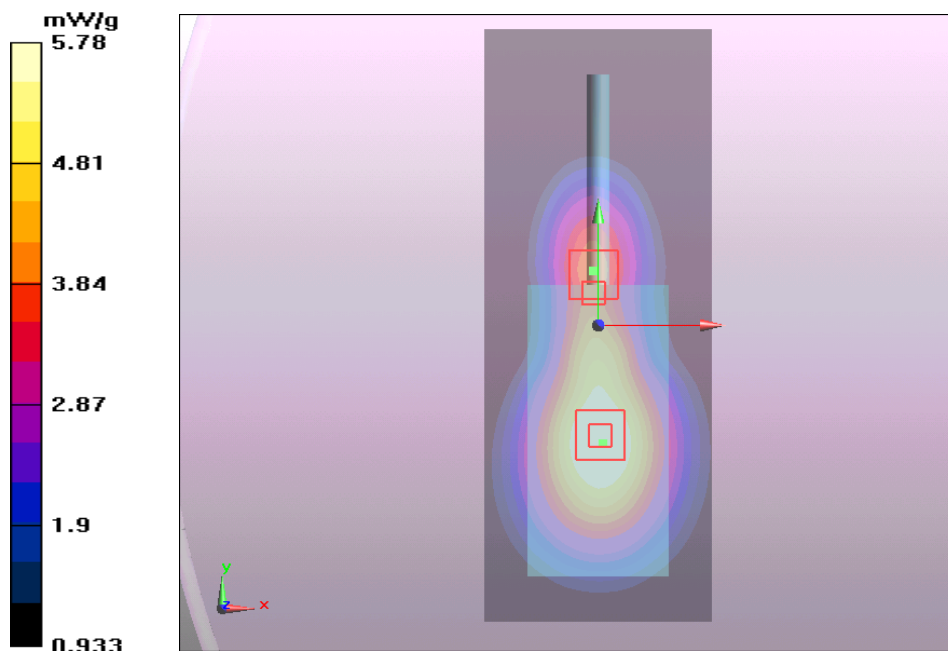

**Figure 20 Body-Worn with Thinner Battery, Belt and Audio Accessory 3, Front towards Ground 851.5MHz(12.5 KHz Channel Spacing)**

**TA Technology (Shanghai) Co., Ltd.**  
**Test Report**

Report No. RZA1203-0346SAR

Page 48 of 98

**Body-Worn with Thinner Battery, Belt and Audio Accessory 4, Front towards Ground 851.5MHz(12.5 KHz Channel Spacing)**

Date/Time: 3/19/2012 6:08:29 PM

Communication System: PTT 800; Frequency: 851.5 MHz; Duty Cycle: 1:1

Medium parameters used (interpolated):  $f = 851.5$  MHz;  $\sigma = 1.01$  mho/m;  $\epsilon_r = 54.1$ ;  $\rho = 1000$  kg/m<sup>3</sup>

Ambient Temperature: 22.3 °C      Liquid Temperature: 21.5°C

Phantom section: Flat Section

DASY5 Configuration:

Probe: EX3DV4 - SN3578; ConvF(8.45, 8.45, 8.45) Calibrated: 6/21/2011;

Electronics: DAE4 Sn871; Calibrated: 11/22/2011

Phantom: ELI 4.0; Type: QDOVA001BA;

Measurement SW: DASY5, V5.2 Build 162; SEMCAD X Version 14.0 Build 59

**Towards Ground Ch 3/Area Scan (51x131x1):** Measurement grid: dx=15mm, dy=15mm

Maximum value of SAR (interpolated) = 7.18 mW/g

**Towards Ground Ch 3/Zoom Scan (7x7x7)/Cube 0:** Measurement grid: dx=5mm, dy=5mm, dz=5mm

Reference Value = 76.9 V/m; Power Drift = -0.051 dB

Peak SAR (extrapolated) = 8.28 W/kg

**SAR(1 g) = 6.59 mW/g; SAR(10 g) = 4.94 mW/g**

Maximum value of SAR (measured) = 6.92 mW/g

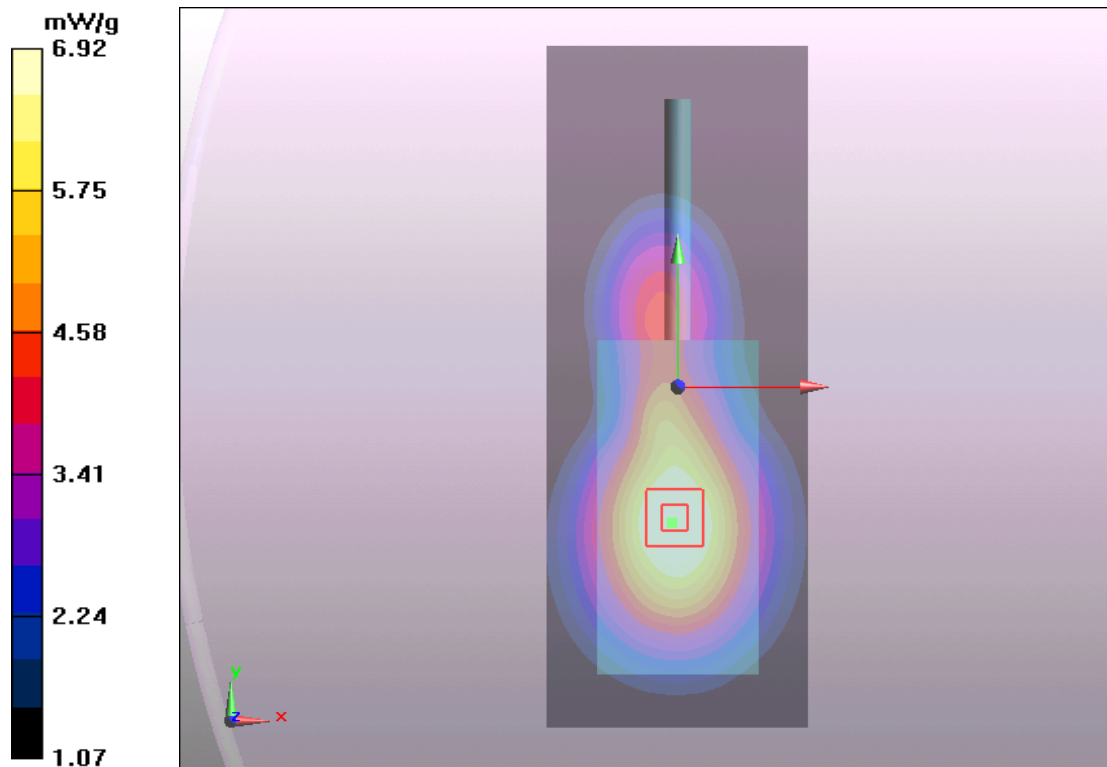

**Figure 21 Body-Worn with Thinner Battery, Belt and Audio Accessory 4, Front towards Ground 851.5MHz(12.5 KHz Channel Spacing)**



**TA Technology (Shanghai) Co., Ltd.**  
**Test Report**

**Body-Worn with Thinner Battery, Belt and Audio Accessory 5, Front towards Ground 851.5MHz(12.5 KHz Channel Spacing)**

Date/Time: 3/19/2012 6:35:06 PM

Communication System: PTT 800; Frequency: 851.5 MHz; Duty Cycle: 1:1

Medium parameters used (interpolated):  $f = 851.5$  MHz;  $\sigma = 1.01$  mho/m;  $\epsilon_r = 54.1$ ;  $\rho = 1000$  kg/m<sup>3</sup>

Ambient Temperature: 22.3 °C      Liquid Temperature: 21.5°C

Phantom section: Flat Section

DASY5 Configuration:

Probe: EX3DV4 - SN3578; ConvF(8.45, 8.45, 8.45) Calibrated: 6/21/2011;

Electronics: DAE4 Sn871; Calibrated: 11/22/2011

Phantom: ELI 4.0; Type: QDOVA001BA;

Measurement SW: DASY5, V5.2 Build 162; SEMCAD X Version 14.0 Build 59

**Towards Ground Ch 3/Area Scan (51x131x1):** Measurement grid: dx=15mm, dy=15mm

Maximum value of SAR (interpolated) = 6.67 mW/g

**Towards Ground Ch 3/Zoom Scan (7x7x7)/Cube 1:** Measurement grid: dx=5mm, dy=5mm, dz=5mm

Reference Value = 77.7 V/m; Power Drift = -0.002 dB

Peak SAR (extrapolated) = 5.16 W/kg

**SAR(1 g) = 3.83 mW/g; SAR(10 g) = 2.7 mW/g**

Maximum value of SAR (measured) = 4.05 mW/g

**Towards Ground Ch 3/Zoom Scan (7x7x7)/Cube 0:** Measurement grid: dx=5mm, dy=5mm, dz=5mm

Reference Value = 77.7 V/m; Power Drift = -0.002 dB

Peak SAR (extrapolated) = 7.68 W/kg

**SAR(1 g) = 6.12 mW/g; SAR(10 g) = 4.58 mW/g**

Maximum value of SAR (measured) = 6.44 mW/g

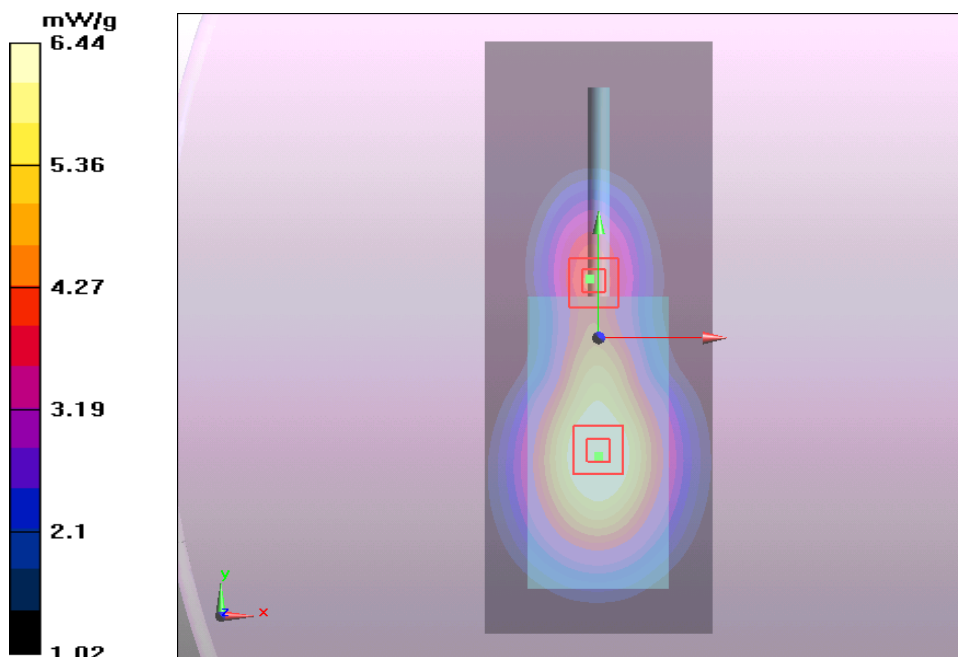

**Figure 22 Body-Worn with Thinner Battery, Belt and Audio Accessory 5, Front towards Ground 851.5MHz(12.5 KHz Channel Spacing)**

**Body-Worn with Thinner Battery, Pocket and Accessory 1, Front towards Ground  
851.5MHz(12.5 KHz Channel Spacing)**

Date/Time: 3/19/2012 2:02:02 PM

Communication System: PTT 800; Frequency: 851.5 MHz; Duty Cycle: 1:1

Medium parameters used (interpolated):  $f = 851.5$  MHz;  $\sigma = 1.01$  mho/m;  $\epsilon_r = 54.1$ ;  $\rho = 1000$  kg/m<sup>3</sup>

Ambient Temperature: 22.3 °C      Liquid Temperature: 21.5 °C

Phantom section: Flat Section

DASY5 Configuration:

Probe: EX3DV4 - SN3578; ConvF(8.45, 8.45, 8.45) Calibrated: 6/21/2011;

Electronics: DAE4 Sn871; Calibrated: 11/22/2011

Phantom: ELI 4.0; Type: QDOVA001BA;

Measurement SW: DASY5, V5.2 Build 162; SEMCAD X Version 14.0 Build 59

**Towards Ground Ch 3/Area Scan (51x131x1):** Measurement grid: dx=15mm, dy=15mm

Maximum value of SAR (interpolated) = 6.2 mW/g

**Towards Ground Ch 3/Zoom Scan (7x7x7)/Cube 0:** Measurement grid: dx=5mm, dy=5mm, dz=5mm

Reference Value = 84 V/m; Power Drift = -0.018 dB

Peak SAR (extrapolated) = 7.07 W/kg

**SAR(1 g) = 5.62 mW/g; SAR(10 g) = 4.21 mW/g**

Maximum value of SAR (measured) = 5.92 mW/g

**Towards Ground Ch 3/Zoom Scan (7x7x7)/Cube 1:** Measurement grid: dx=5mm, dy=5mm, dz=5mm

Reference Value = 84 V/m; Power Drift = -0.018 dB

Peak SAR (extrapolated) = 6.55 W/kg

**SAR(1 g) = 3.96 mW/g; SAR(10 g) = 2.69 mW/g**

Maximum value of SAR (measured) = 4.57 mW/g

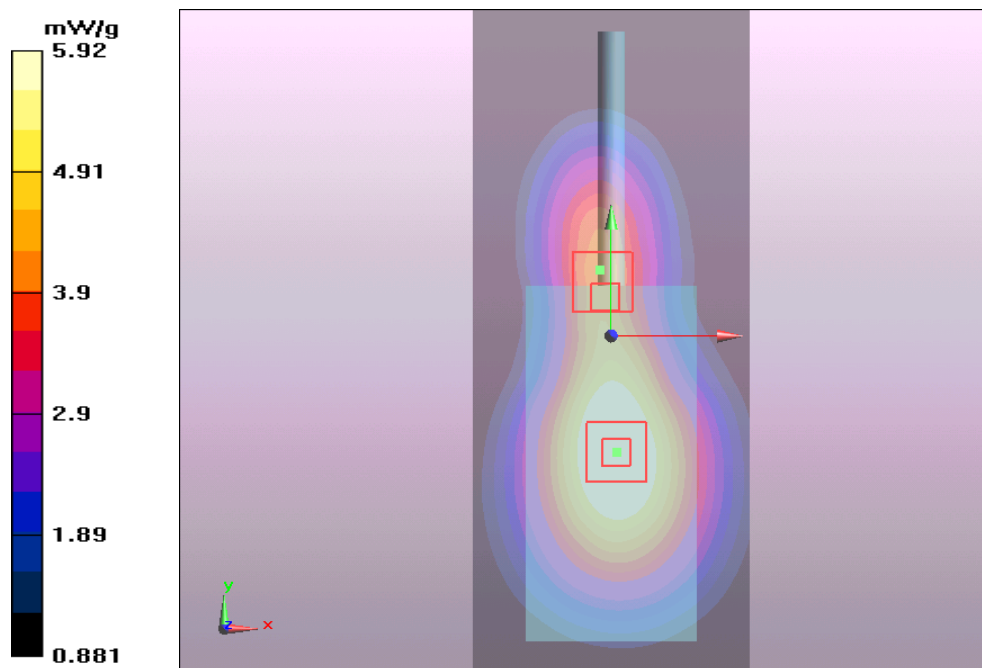

**Figure 23 Body-Worn with Thinner Battery, Pocket and Accessory 1, Front towards Ground  
851.5MHz(12.5 KHz Channel Spacing)**

**Body-Worn with Thinner Battery, Pocket, Leather and Accessory 1, Front towards Ground 851.5MHz(12.5 KHz Channel Spacing)**

Date/Time: 3/19/2012 9:57:23 PM

Communication System: PTT 800; Frequency: 851.5 MHz; Duty Cycle: 1:1

Medium parameters used (interpolated):  $f = 851.5$  MHz;  $\sigma = 1.01$  mho/m;  $\epsilon_r = 54.1$ ;  $\rho = 1000$  kg/m<sup>3</sup>

Ambient Temperature: 22.3 °C      Liquid Temperature: 21.5°C

Phantom section: Flat Section

DASY5 Configuration:

Probe: EX3DV4 - SN3578; ConvF(8.45, 8.45, 8.45) Calibrated: 6/21/2011;

Electronics: DAE4 Sn871; Calibrated: 11/22/2011

Phantom: ELI 4.0; Type: QDOVA001BA;

Measurement SW: DASY5, V5.2 Build 162; SEMCAD X Version 14.0 Build 59

**Towards Ground Ch 3/Area Scan (51x131x1):** Measurement grid: dx=15mm, dy=15mm

Maximum value of SAR (interpolated) = 4.32 mW/g

**Towards Ground Ch 3/Zoom Scan (7x7x7)/Cube 0:** Measurement grid: dx=5mm, dy=5mm, dz=5mm

Reference Value = 39.3 V/m; Power Drift = -0.030 dB

Peak SAR (extrapolated) = 5.15 W/kg

**SAR(1 g) = 3.92 mW/g; SAR(10 g) = 2.88 mW/g**

Maximum value of SAR (measured) = 4.12 mW/g

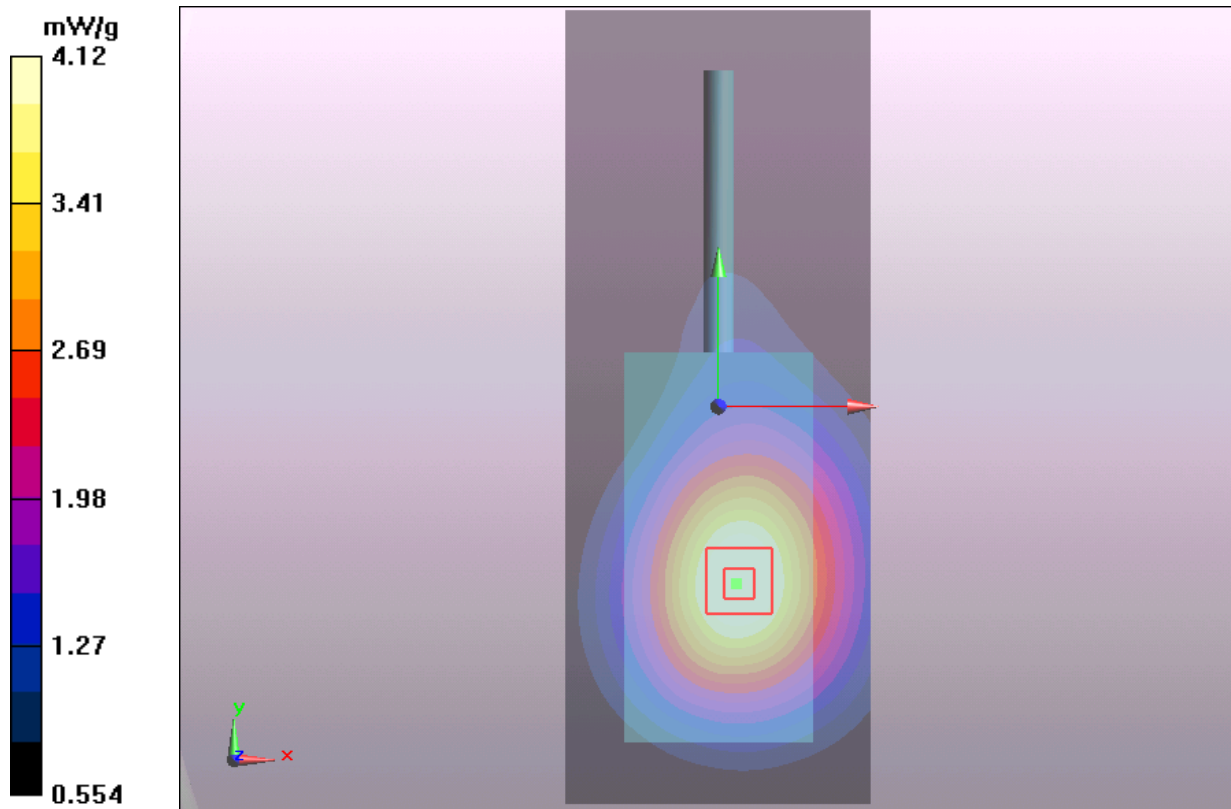

**Figure 24 Body-Worn with Thinner Battery, Pocket, Leather and Accessory 1, Front towards Ground 851.5MHz(12.5 KHz Channel Spacing)**

**TA Technology (Shanghai) Co., Ltd.**  
**Test Report**

**Body-Worn for Digital with Thinner Battery, Belt and Accessory 1, Front towards Ground 851.5MHz**

Date/Time: 3/19/2012 7:05:50 PM

Communication System: PTT 800 Digital; Frequency: 851.5 MHz; Duty Cycle: 1:1.99986

Medium parameters used (interpolated):  $f = 851.5$  MHz;  $\sigma = 1.01$  mho/m;  $\epsilon_r = 54.1$ ;  $\rho = 1000$  kg/m<sup>3</sup>

Ambient Temperature: 22.3 °C      Liquid Temperature: 21.5 °C

Phantom section: Flat Section

DASY5 Configuration:

Probe: EX3DV4 - SN3578; ConvF(8.45, 8.45, 8.45) Calibrated: 6/21/2011;

Electronics: DAE4 Sn871; Calibrated: 11/22/2011

Phantom: ELI 4.0; Type: QDOVA001BA;

Measurement SW: DASY5, V5.2 Build 162; SEMCAD X Version 14.0 Build 59

**Towards Ground Ch 3 2/Area Scan (51x131x1):** Measurement grid: dx=15mm, dy=15mm

Maximum value of SAR (interpolated) = 3.38 mW/g

**Towards Ground Ch 3 2/Zoom Scan (7x7x7)/Cube 1:** Measurement grid: dx=5mm, dy=5mm, dz=5mm

Reference Value = 52.4 V/m; Power Drift = -0.069 dB

Peak SAR (extrapolated) = 4.76 W/kg

**SAR(1 g) = 2.83 mW/g; SAR(10 g) = 1.83 mW/g**

Maximum value of SAR (measured) = 3.17 mW/g

**Towards Ground Ch 3 2/Zoom Scan (7x7x7)/Cube 0:** Measurement grid: dx=5mm, dy=5mm, dz=5mm

Reference Value = 52.4 V/m; Power Drift = -0.069 dB

Peak SAR (extrapolated) = 4.15 W/kg

**SAR(1 g) = 3.13 mW/g; SAR(10 g) = 2.31 mW/g**

Maximum value of SAR (measured) = 3.34 mW/g

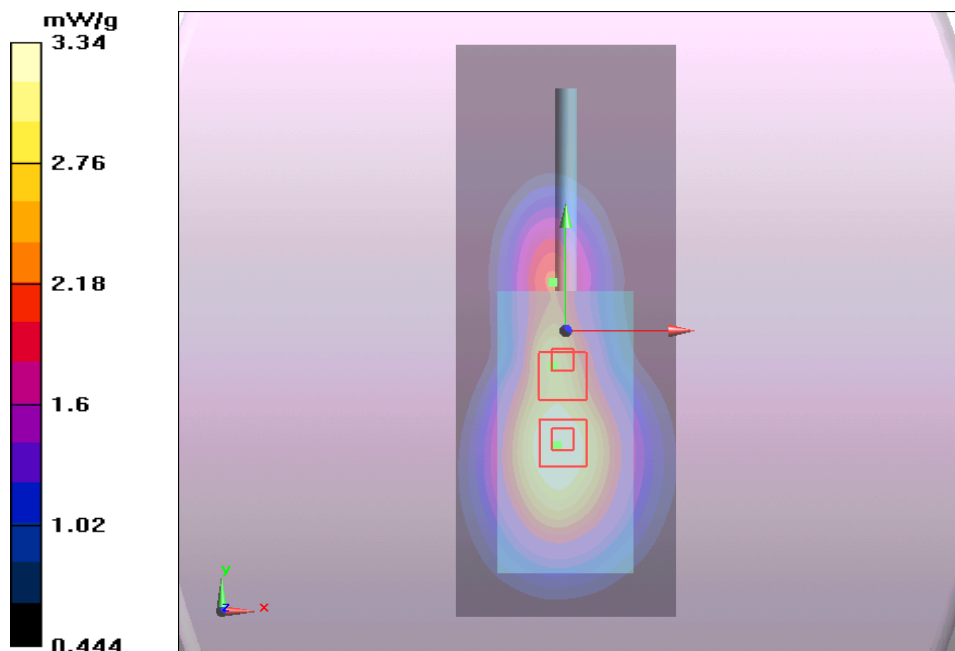

**Figure 25 Body-Worn for Digital with Thinner Battery, Belt and Accessory 1, Front towards Ground 851.5MHz**

**TA Technology (Shanghai) Co., Ltd.**  
**Test Report**

**Body-Worn with Thicker Battery, Belt and Accessory 1, Front towards Ground  
851.5MHz(12.5 KHz Channel Spacing)**

Date/Time: 3/19/2012 7:41:48 PM

Communication System: PTT 800; Frequency: 851.5 MHz; Duty Cycle: 1:1

Medium parameters used (interpolated):  $f = 851.5$  MHz;  $\sigma = 1.01$  mho/m;  $\epsilon_r = 54.1$ ;  $\rho = 1000$  kg/m<sup>3</sup>

Ambient Temperature: 22.3 °C      Liquid Temperature: 21.5°C

Phantom section: Flat Section

DASY5 Configuration:

Probe: EX3DV4 - SN3578; ConvF(8.45, 8.45, 8.45) Calibrated: 6/21/2011;

Electronics: DAE4 Sn871; Calibrated: 11/22/2011

Phantom: ELI 4.0; Type: QDOVA001BA;

Measurement SW: DASY5, V5.2 Build 162; SEMCAD X Version 14.0 Build 59

**Towards Ground Ch 3/Area Scan (51x131x1):** Measurement grid: dx=15mm, dy=15mm

Maximum value of SAR (interpolated) = 8.19 mW/g

**Towards Ground Ch 3/Zoom Scan (7x7x7)/Cube 1:** Measurement grid: dx=5mm, dy=5mm, dz=5mm

Reference Value = 80.5 V/m; Power Drift = -0.049 dB

Peak SAR (extrapolated) = 13.8 W/kg

**SAR(1 g) = 7.25 mW/g; SAR(10 g) = 4.15 mW/g**

Maximum value of SAR (measured) = 8.21 mW/g

**Towards Ground Ch 3/Zoom Scan (7x7x7)/Cube 0:** Measurement grid: dx=5mm, dy=5mm, dz=5mm

Reference Value = 80.5 V/m; Power Drift = -0.049 dB

Peak SAR (extrapolated) = 9.42 W/kg

**SAR(1 g) = 7.43 mW/g; SAR(10 g) = 5.48 mW/g**

Maximum value of SAR (measured) = 7.86 mW/g

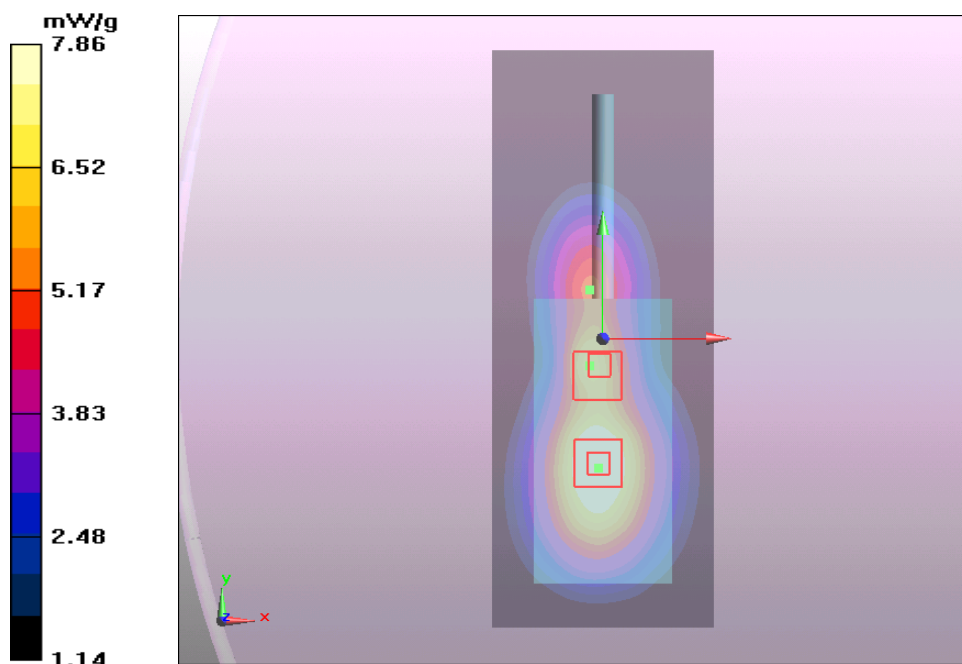

**Figure 26 Body-Worn with Thicker Battery, Belt and Accessory 1, Front towards Ground  
851.5MHz(12.5 KHz Channel Spacing)**

# TA Technology (Shanghai) Co., Ltd. Test Report

Report No. RZA1203-0346SAR

Page 54 of 98

## ANNEX D: Probe Calibration Certificate

**Calibration Laboratory of  
Schmid & Partner  
Engineering AG**  
Zeughausstrasse 43, 8004 Zurich, Switzerland



**S** Schweizerischer Kalibrierdienst  
**C** Service suisse d'étalonnage  
**S** Servizio svizzero di taratura  
**S** Swiss Calibration Service

Accredited by the Swiss Accreditation Service (SAS)  
The Swiss Accreditation Service is one of the signatories to the EA  
Multilateral Agreement for the recognition of calibration certificates

Accreditation No.: **SCS 108**

Client **Auden**

Certificate No: **EX3-3578\_Jun11**

### CALIBRATION CERTIFICATE

Object **EX3DV4 - SN:3578**

Calibration procedure(s) **QA CAL-01.v8, QA CAL-14.v3, QA CAL-23.v4, QA CAL-25.v4  
Calibration procedure for dosimetric E-field probes**

Calibration date: **June 21, 2011**

This calibration certificate documents the traceability to national standards, which realize the physical units of measurements (SI).  
The measurements and the uncertainties with confidence probability are given on the following pages and are part of the certificate.

All calibrations have been conducted in the closed laboratory facility: environment temperature (22 ± 3)°C and humidity < 70%.

Calibration Equipment used (M&TE critical for calibration)

Primary Standards	ID	Cal Date (Certificate No.)	Scheduled Calibration
Power meter E4419B	GB41293874	31-Mar-11 (No. 217-01372)	Apr-12
Power sensor E4412A	MY41498087	31-Mar-11 (No. 217-01372)	Apr-12
Reference 3 dB Attenuator	SN: S5054 (3c)	29-Mar-11 (No. 217-01369)	Apr-12
Reference 20 dB Attenuator	SN: S5086 (20b)	29-Mar-11 (No. 217-01367)	Apr-12
Reference 30 dB Attenuator	SN: S5129 (30b)	29-Mar-11 (No. 217-01370)	Apr-12
Reference Probe ES3DV2	SN: 3013	29-Dec-10 (No. ES3-3013_Dec10)	Dec-11
DAE4	SN: 654	3-May-11 (No. DAE4-654_May11)	May-12
Secondary Standards	ID	Check Date (in house)	Scheduled Check
RF generator HP 8648C	US3642U01700	4-Aug-99 (in house check Oct-09)	In house check: Oct-11
Network Analyzer HP 8753E	US37390585	18-Oct-01 (in house check Oct-10)	In house check: Oct-11

	Name	Function	Signature
Calibrated by:	Katja Pokovic	Technical Manager	
Approved by:	Niels Kuster	Quality Manager	
			Issued: June 21, 2011

This calibration certificate shall not be reproduced except in full without written approval of the laboratory.

Calibration Laboratory of  
Schmid & Partner  
Engineering AG  
Zeughausstrasse 43, 8004 Zurich, Switzerland



S Schweizerischer Kalibrierdienst  
C Service suisse d'étalonnage  
S Servizio svizzero di taratura  
S Swiss Calibration Service

Accredited by the Swiss Accreditation Service (SAS)  
The Swiss Accreditation Service is one of the signatories to the EA  
Multilateral Agreement for the recognition of calibration certificates

Accreditation No.: SCS 108

**Glossary:**

TSL	tissue simulating liquid
NORM <sub>x,y,z</sub>	sensitivity in free space
ConvF	sensitivity in TSL / NORM <sub>x,y,z</sub>
DCP	diode compression point
CF	crest factor (1/duty_cycle) of the RF signal
A, B, C	modulation dependent linearization parameters
Polarization $\varphi$	$\varphi$ rotation around probe axis
Polarization $\vartheta$	$\vartheta$ rotation around an axis that is in the plane normal to probe axis (at measurement center), i.e., $\vartheta = 0$ is normal to probe axis

**Calibration is Performed According to the Following Standards:**

- IEEE Std 1528-2003, "IEEE Recommended Practice for Determining the Peak Spatial-Averaged Specific Absorption Rate (SAR) in the Human Head from Wireless Communications Devices: Measurement Techniques", December 2003
- IEC 62209-1, "Procedure to measure the Specific Absorption Rate (SAR) for hand-held devices used in close proximity to the ear (frequency range of 300 MHz to 3 GHz)", February 2005

**Methods Applied and Interpretation of Parameters:**

- NORM<sub>x,y,z</sub>:** Assessed for E-field polarization  $\vartheta = 0$  ( $f \leq 900$  MHz in TEM-cell;  $f > 1800$  MHz: R22 waveguide). NORM<sub>x,y,z</sub> are only intermediate values, i.e., the uncertainties of NORM<sub>x,y,z</sub> does not affect the E<sup>2</sup>-field uncertainty inside TSL (see below ConvF).
- NORM(f)<sub>x,y,z</sub> = NORM<sub>x,y,z</sub> \* frequency\_response** (see Frequency Response Chart). This linearization is implemented in DASY4 software versions later than 4.2. The uncertainty of the frequency response is included in the stated uncertainty of ConvF.
- DCP<sub>x,y,z</sub>:** DCP are numerical linearization parameters assessed based on the data of power sweep with CW signal (no uncertainty required). DCP does not depend on frequency nor media.
- PAR:** PAR is the Peak to Average Ratio that is not calibrated but determined based on the signal characteristics
- A<sub>x,y,z</sub>; B<sub>x,y,z</sub>; C<sub>x,y,z</sub>; VR<sub>x,y,z</sub>:** A, B, C are numerical linearization parameters assessed based on the data of power sweep for specific modulation signal. The parameters do not depend on frequency nor media. VR is the maximum calibration range expressed in RMS voltage across the diode.
- ConvF and Boundary Effect Parameters:** Assessed in flat phantom using E-field (or Temperature Transfer Standard for  $f \leq 800$  MHz) and inside waveguide using analytical field distributions based on power measurements for  $f > 800$  MHz. The same setups are used for assessment of the parameters applied for boundary compensation (alpha, depth) of which typical uncertainty values are given. These parameters are used in DASY4 software to improve probe accuracy close to the boundary. The sensitivity in TSL corresponds to NORM<sub>x,y,z</sub> \* ConvF whereby the uncertainty corresponds to that given for ConvF. A frequency dependent ConvF is used in DASY version 4.4 and higher which allows extending the validity from  $\pm 50$  MHz to  $\pm 100$  MHz.
- Spherical isotropy (3D deviation from isotropy):** in a field of low gradients realized using a flat phantom exposed by a patch antenna.
- Sensor Offset:** The sensor offset corresponds to the offset of virtual measurement center from the probe tip (on probe axis). No tolerance required.

EX3DV4 – SN:3578

June 21, 2011

# Probe EX3DV4

## SN:3578

Manufactured: November 4, 2005  
Calibrated: June 21, 2011

Calibrated for DASY/EASY Systems  
(Note: non-compatible with DASY2 system!)



# TA Technology (Shanghai) Co., Ltd.

## Test Report

EX3DV4- SN:3578

June 21, 2011

### DASY/EASY - Parameters of Probe: EX3DV4 - SN:3578

#### Basic Calibration Parameters

	Sensor X	Sensor Y	Sensor Z	Unc (k=2)
Norm ( $\mu\text{V}/(\text{V}/\text{m})^2$ ) <sup>A</sup>	0.53	0.50	0.56	$\pm 10.1 \%$
DCP (mV) <sup>B</sup>	101.0	99.8	100.5	

#### Modulation Calibration Parameters

UID	Communication System Name	PAR		A dB	B dB	C dB	VR mV	Unc <sup>E</sup> (k=2)
10000	CW	0.00	X	0.00	0.00	1.00	117.4	$\pm 1.7 \%$
			Y	0.00	0.00	1.00	116.2	
			Z	0.00	0.00	1.00	123.2	

The reported uncertainty of measurement is stated as the standard uncertainty of measurement multiplied by the coverage factor k=2, which for a normal distribution corresponds to a coverage probability of approximately 95%.

<sup>A</sup> The uncertainties of NormX,Y,Z do not affect the E<sup>2</sup>-field uncertainty inside TSL (see Pages 5 and 6).

<sup>B</sup> Numerical linearization parameter: uncertainty not required.

<sup>E</sup> Uncertainty is determined using the max. deviation from linear response applying rectangular distribution and is expressed for the square of the field value.

# TA Technology (Shanghai) Co., Ltd.

## Test Report

EX3DV4- SN:3578

June 21, 2011

### DASY/EASY - Parameters of Probe: EX3DV4 - SN:3578

#### Calibration Parameter Determined in Head Tissue Simulating Media

f (MHz) <sup>C</sup>	Relative Permittivity <sup>F</sup>	Conductivity (S/m) <sup>F</sup>	ConvF X	ConvF Y	ConvF Z	Alpha	Depth (mm)	Unct. (k=2)
750	41.9	0.89	8.66	8.66	8.66	0.80	0.71	± 12.0 %
835	41.5	0.90	8.33	8.33	8.33	0.80	0.69	± 12.0 %
900	41.5	0.97	8.21	8.21	8.21	0.80	0.69	± 12.0 %
1750	40.1	1.37	7.62	7.62	7.62	0.80	0.70	± 12.0 %
1900	40.0	1.40	7.26	7.26	7.26	0.80	0.69	± 12.0 %
2000	40.0	1.40	7.21	7.21	7.21	0.80	0.68	± 12.0 %
2450	39.2	1.80	6.42	6.42	6.42	0.80	0.68	± 12.0 %
5200	36.0	4.66	4.26	4.26	4.26	0.40	1.80	± 13.1 %
5300	35.9	4.76	4.06	4.06	4.06	0.40	1.80	± 13.1 %
5500	35.6	4.96	4.12	4.12	4.12	0.45	1.80	± 13.1 %
5600	35.5	5.07	3.94	3.94	3.94	0.40	1.80	± 13.1 %
5800	35.3	5.27	3.84	3.84	3.84	0.50	1.80	± 13.1 %

<sup>C</sup> Frequency validity of ± 100 MHz only applies for DASY v4.4 and higher (see Page 2), else it is restricted to ± 50 MHz. The uncertainty is the RSS of the ConvF uncertainty at calibration frequency and the uncertainty for the indicated frequency band.

<sup>F</sup> At frequencies below 3 GHz, the validity of tissue parameters ( $\epsilon$  and  $\sigma$ ) can be relaxed to ± 10% if liquid compensation formula is applied to measured SAR values. At frequencies above 3 GHz, the validity of tissue parameters ( $\epsilon$  and  $\sigma$ ) is restricted to ± 5%. The uncertainty is the RSS of the ConvF uncertainty for indicated target tissue parameters.

# TA Technology (Shanghai) Co., Ltd.

## Test Report

EX3DV4- SN:3578

June 21, 2011

### DASY/EASY - Parameters of Probe: EX3DV4- SN:3578

#### Calibration Parameter Determined in Body Tissue Simulating Media

f (MHz) <sup>C</sup>	Relative Permittivity <sup>F</sup>	Conductivity (S/m) <sup>F</sup>	ConvF X	ConvF Y	ConvF Z	Alpha	Depth (mm)	Unct. (k=2)
750	55.5	0.96	8.77	8.77	8.77	0.80	0.75	± 12.0 %
835	55.2	0.97	8.45	8.45	8.45	0.80	0.75	± 12.0 %
900	55.0	1.05	8.34	8.34	8.34	0.80	0.72	± 12.0 %
1750	53.4	1.49	7.19	7.19	7.19	0.80	0.75	± 12.0 %
1900	53.3	1.52	6.68	6.68	6.68	0.80	0.73	± 12.0 %
2000	53.3	1.52	6.68	6.68	6.68	0.80	0.73	± 12.0 %
2450	52.7	1.95	6.18	6.18	6.18	0.80	0.50	± 12.0 %
5200	49.0	5.30	3.74	3.74	3.74	0.55	1.90	± 13.1 %
5300	48.9	5.42	3.49	3.49	3.49	0.55	1.90	± 13.1 %
5500	48.6	5.65	3.40	3.40	3.40	0.60	1.90	± 13.1 %
5600	48.5	5.77	3.11	3.11	3.11	0.65	1.90	± 13.1 %
5800	48.2	6.00	3.23	3.23	3.23	0.65	1.90	± 13.1 %

<sup>C</sup> Frequency validity of ± 100 MHz only applies for DASY v4.4 and higher (see Page 2), else it is restricted to ± 50 MHz. The uncertainty is the RSS of the ConvF uncertainty at calibration frequency and the uncertainty for the indicated frequency band.

<sup>F</sup> At frequencies below 3 GHz, the validity of tissue parameters ( $\epsilon$  and  $\sigma$ ) can be relaxed to ± 10% if liquid compensation formula is applied to measured SAR values. At frequencies above 3 GHz, the validity of tissue parameters ( $\epsilon$  and  $\sigma$ ) is restricted to ± 5%. The uncertainty is the RSS of the ConvF uncertainty for indicated target tissue parameters.

EX3DV4- SN:3578

June 21, 2011

**Frequency Response of E-Field**  
(TEM-Cell:ifi110 EXX, Waveguide: R22)

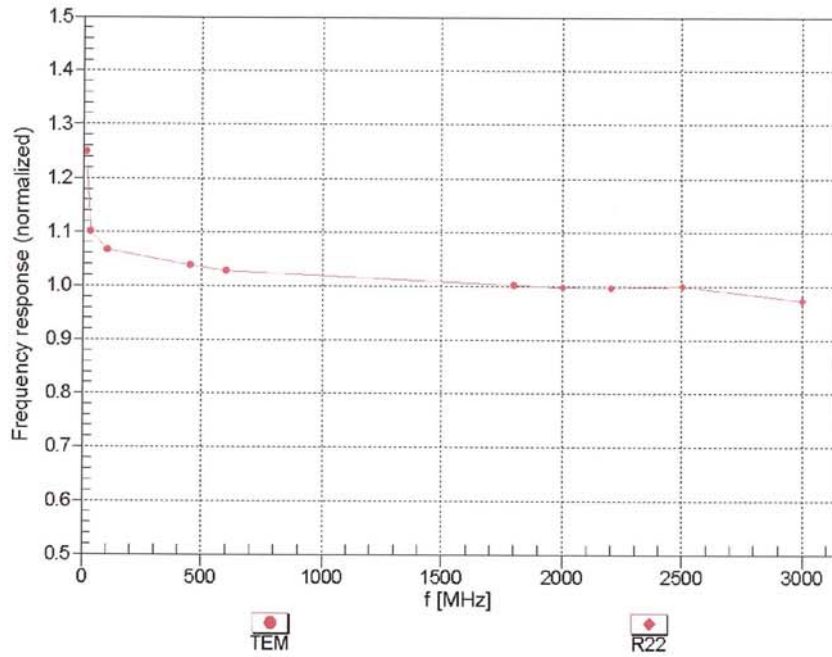

Uncertainty of Frequency Response of E-field:  $\pm 6.3\%$  (k=2)

EX3DV4- SN:3578

June 21, 2011

Receiving Pattern ( $\phi$ ),  $\vartheta = 0^\circ$

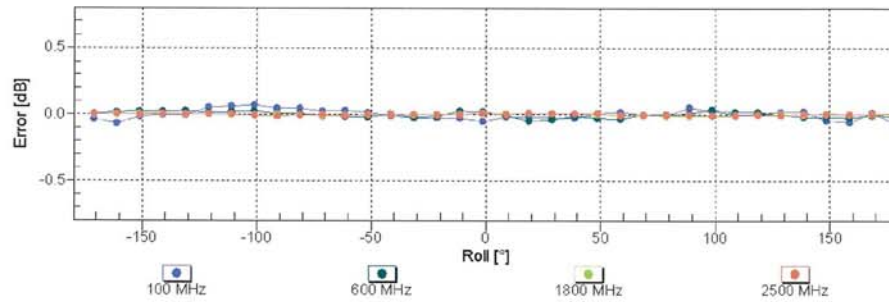
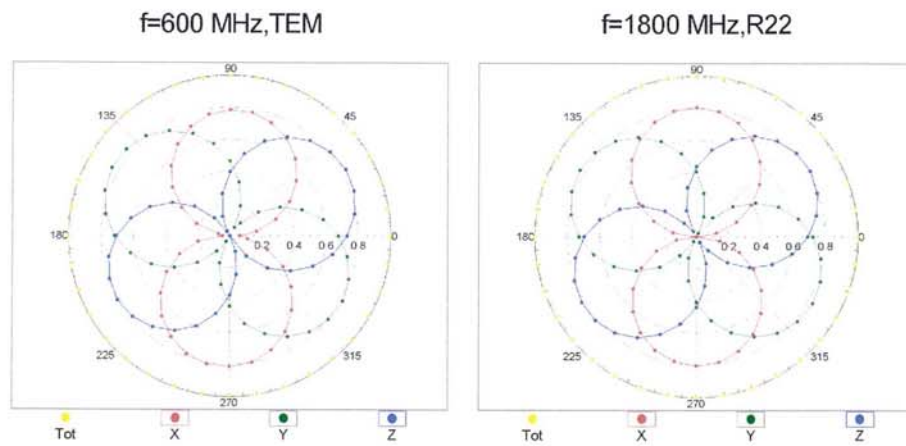

Uncertainty of Axial Isotropy Assessment:  $\pm 0.5\%$  ( $k=2$ )

EX3DV4- SN:3578

June 21, 2011

**Dynamic Range  $f(SAR_{head})$**   
(TEM cell ,  $f = 900$  MHz)

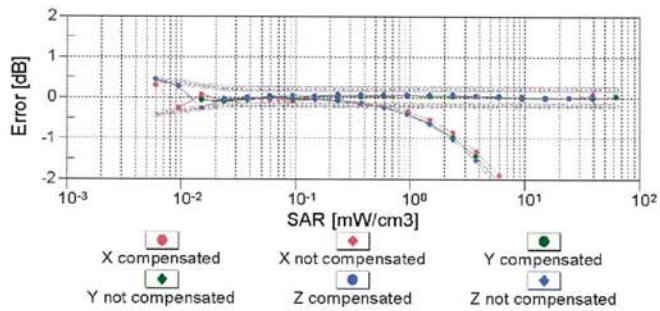
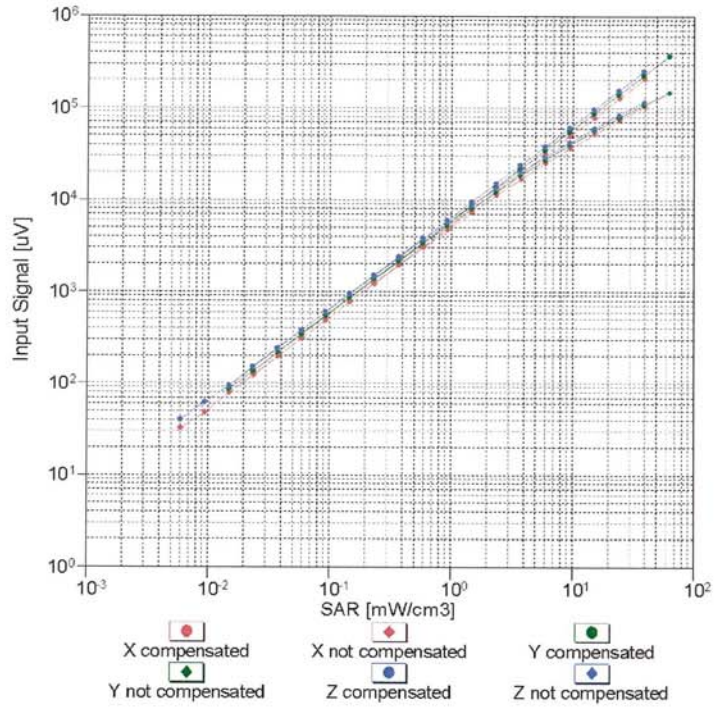

**Uncertainty of Linearity Assessment:  $\pm 0.6\%$  ( $k=2$ )**

EX3DV4-SN:3578

June 21, 2011

### Conversion Factor Assessment

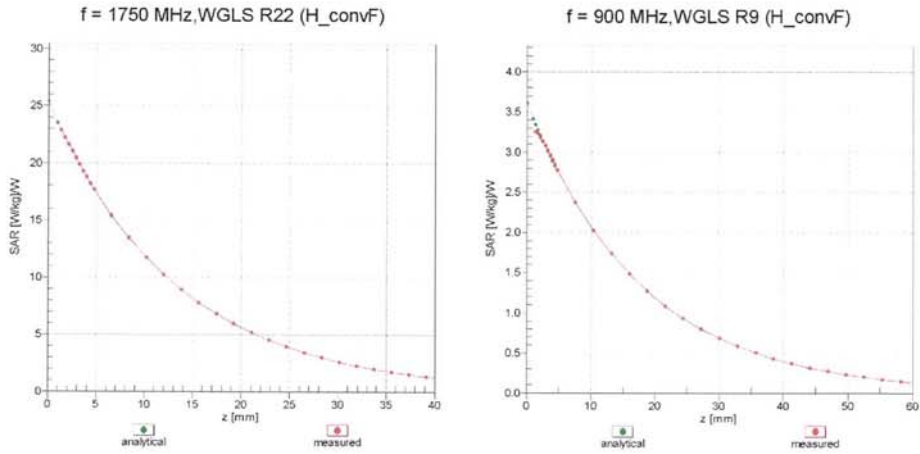

### Deviation from Isotropy in Liquid Error ( $\phi$ , $\theta$ ), f = 900 MHz

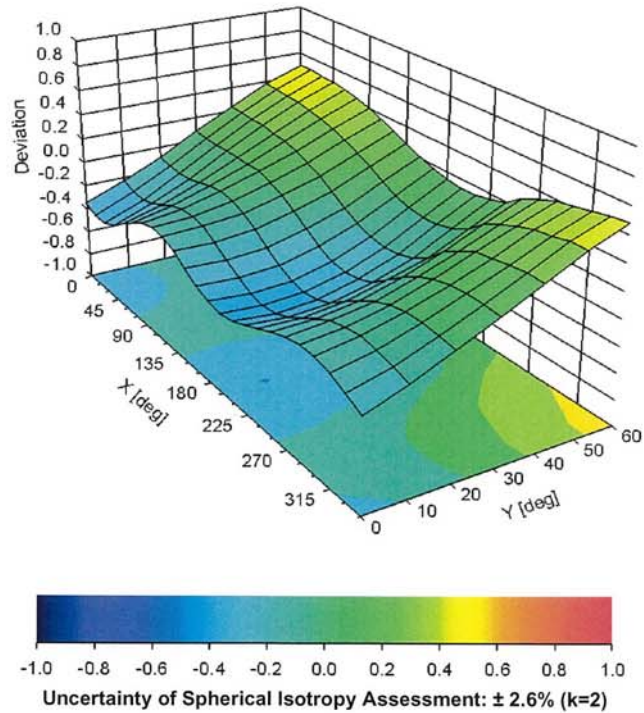

EX3DV4- SN:3578

June 21, 2011

### **DASY/EASY - Parameters of Probe: EX3DV4 - SN:3578**

#### **Other Probe Parameters**

Sensor Arrangement	Triangular
Connector Angle (°)	Not applicable
Mechanical Surface Detection Mode	enabled
Optical Surface Detection Mode	disabled
Probe Overall Length	337 mm
Probe Body Diameter	10 mm
Tip Length	9 mm
Tip Diameter	2.5 mm
Probe Tip to Sensor X Calibration Point	1 mm
Probe Tip to Sensor Y Calibration Point	1 mm
Probe Tip to Sensor Z Calibration Point	1 mm
Recommended Measurement Distance from Surface	2 mm



# TA Technology (Shanghai) Co., Ltd. Test Report

Report No. RZA1203-0346SAR

Page 65 of 98

## ANNEX E: D835V2 Dipole Calibration Certificate

**Calibration Laboratory of  
Schmid & Partner  
Engineering AG**  
Zeughausstrasse 43, 8004 Zurich, Switzerland



**S** Schweizerischer Kalibrierdienst  
**C** Service suisse d'étalonnage  
**S** Servizio svizzero di taratura  
**S** Swiss Calibration Service

Accredited by the Swiss Accreditation Service (SAS)  
The Swiss Accreditation Service is one of the signatories to the EA  
Multilateral Agreement for the recognition of calibration certificates

Accreditation No.: **SCS 108**

Client **TA-Shanghai (Auden)**

Certificate No: **D835V2-4d020\_Aug11**

### CALIBRATION CERTIFICATE

Object	D835V2 - SN: 4d020																																														
Calibration procedure(s)	QA CAL-05.v8 Calibration procedure for dipole validation kits above 700 MHz																																														
Calibration date:	August 26, 2011																																														
<p>This calibration certificate documents the traceability to national standards, which realize the physical units of measurements (SI). The measurements and the uncertainties with confidence probability are given on the following pages and are part of the certificate.</p> <p>All calibrations have been conducted in the closed laboratory facility: environment temperature (22 ± 3)°C and humidity &lt; 70%.</p> <p>Calibration Equipment used (M&amp;TE critical for calibration)</p> <table border="1" style="width: 100%; border-collapse: collapse;"> <thead> <tr> <th>Primary Standards</th> <th>ID #</th> <th>Cal Date (Certificate No.)</th> <th>Scheduled Calibration</th> </tr> </thead> <tbody> <tr> <td>Power meter EPM-442A</td> <td>GB37480704</td> <td>06-Oct-10 (No. 217-01266)</td> <td>Oct-11</td> </tr> <tr> <td>Power sensor HP 8481A</td> <td>US37292783</td> <td>06-Oct-10 (No. 217-01266)</td> <td>Oct-11</td> </tr> <tr> <td>Reference 20 dB Attenuator</td> <td>SN: S5086 (20b)</td> <td>29-Mar-11 (No. 217-01367)</td> <td>Apr-12</td> </tr> <tr> <td>Type-N mismatch combination</td> <td>SN: 5047.2 / 06327</td> <td>29-Mar-11 (No. 217-01371)</td> <td>Apr-12</td> </tr> <tr> <td>Reference Probe ES3DV3</td> <td>SN: 3205</td> <td>29-Apr-11 (No. ES3-3205_Apr11)</td> <td>Apr-12</td> </tr> <tr> <td>DAE4</td> <td>SN: 601</td> <td>04-Jul-11 (No. DAE4-601_Jul11)</td> <td>Jul-12</td> </tr> </tbody> </table> <table border="1" style="width: 100%; border-collapse: collapse;"> <thead> <tr> <th>Secondary Standards</th> <th>ID #</th> <th>Check Date (in house)</th> <th>Scheduled Check</th> </tr> </thead> <tbody> <tr> <td>Power sensor HP 8481A</td> <td>MY41092317</td> <td>18-Oct-02 (in house check Oct-09)</td> <td>In house check: Oct-11</td> </tr> <tr> <td>RF generator R&amp;S SMT-06</td> <td>100005</td> <td>04-Aug-99 (in house check Oct-09)</td> <td>In house check: Oct-11</td> </tr> <tr> <td>Network Analyzer HP 8753E</td> <td>US37390585 S4206</td> <td>18-Oct-01 (in house check Oct-10)</td> <td>In house check: Oct-11</td> </tr> </tbody> </table>				Primary Standards	ID #	Cal Date (Certificate No.)	Scheduled Calibration	Power meter EPM-442A	GB37480704	06-Oct-10 (No. 217-01266)	Oct-11	Power sensor HP 8481A	US37292783	06-Oct-10 (No. 217-01266)	Oct-11	Reference 20 dB Attenuator	SN: S5086 (20b)	29-Mar-11 (No. 217-01367)	Apr-12	Type-N mismatch combination	SN: 5047.2 / 06327	29-Mar-11 (No. 217-01371)	Apr-12	Reference Probe ES3DV3	SN: 3205	29-Apr-11 (No. ES3-3205_Apr11)	Apr-12	DAE4	SN: 601	04-Jul-11 (No. DAE4-601_Jul11)	Jul-12	Secondary Standards	ID #	Check Date (in house)	Scheduled Check	Power sensor HP 8481A	MY41092317	18-Oct-02 (in house check Oct-09)	In house check: Oct-11	RF generator R&S SMT-06	100005	04-Aug-99 (in house check Oct-09)	In house check: Oct-11	Network Analyzer HP 8753E	US37390585 S4206	18-Oct-01 (in house check Oct-10)	In house check: Oct-11
Primary Standards	ID #	Cal Date (Certificate No.)	Scheduled Calibration																																												
Power meter EPM-442A	GB37480704	06-Oct-10 (No. 217-01266)	Oct-11																																												
Power sensor HP 8481A	US37292783	06-Oct-10 (No. 217-01266)	Oct-11																																												
Reference 20 dB Attenuator	SN: S5086 (20b)	29-Mar-11 (No. 217-01367)	Apr-12																																												
Type-N mismatch combination	SN: 5047.2 / 06327	29-Mar-11 (No. 217-01371)	Apr-12																																												
Reference Probe ES3DV3	SN: 3205	29-Apr-11 (No. ES3-3205_Apr11)	Apr-12																																												
DAE4	SN: 601	04-Jul-11 (No. DAE4-601_Jul11)	Jul-12																																												
Secondary Standards	ID #	Check Date (in house)	Scheduled Check																																												
Power sensor HP 8481A	MY41092317	18-Oct-02 (in house check Oct-09)	In house check: Oct-11																																												
RF generator R&S SMT-06	100005	04-Aug-99 (in house check Oct-09)	In house check: Oct-11																																												
Network Analyzer HP 8753E	US37390585 S4206	18-Oct-01 (in house check Oct-10)	In house check: Oct-11																																												
Calibrated by:	Name <b>Jeton Kastrati</b>	Function <b>Laboratory Technician</b>	Signature 																																												
Approved by:	Name <b>Katja Pokovic</b>	Technical Manager																																													
Issued: August 26, 2011																																															
This calibration certificate shall not be reproduced except in full without written approval of the laboratory.																																															

# TA Technology (Shanghai) Co., Ltd.

## Test Report

Report No. RZA1203-0346SAR

Page 66 of 98

**Calibration Laboratory of  
Schmid & Partner  
Engineering AG**  
Zeughausstrasse 43, 8004 Zurich, Switzerland



**S** Schweizerischer Kalibrierdienst  
**C** Service suisse d'étalonnage  
**S** Servizio svizzero di taratura  
**S** Swiss Calibration Service

Accredited by the Swiss Accreditation Service (SAS)

The Swiss Accreditation Service is one of the signatories to the EA  
Multilateral Agreement for the recognition of calibration certificates

Accreditation No.: **SCS 108**

### Glossary:

TSL	tissue simulating liquid
ConvF	sensitivity in TSL / NORM x,y,z
N/A	not applicable or not measured

### Calibration is Performed According to the Following Standards:

- IEEE Std 1528-2003, "IEEE Recommended Practice for Determining the Peak Spatial-Averaged Specific Absorption Rate (SAR) in the Human Head from Wireless Communications Devices: Measurement Techniques", December 2003
- IEC 62209-1, "Procedure to measure the Specific Absorption Rate (SAR) for hand-held devices used in close proximity to the ear (frequency range of 300 MHz to 3 GHz)", February 2005
- Federal Communications Commission Office of Engineering & Technology (FCC OET), "Evaluating Compliance with FCC Guidelines for Human Exposure to Radiofrequency Electromagnetic Fields; Additional Information for Evaluating Compliance of Mobile and Portable Devices with FCC Limits for Human Exposure to Radiofrequency Emissions", Supplement C (Edition 01-01) to Bulletin 65

### Additional Documentation:

- DASY4/5 System Handbook

### Methods Applied and Interpretation of Parameters:

- Measurement Conditions:** Further details are available from the Validation Report at the end of the certificate. All figures stated in the certificate are valid at the frequency indicated.
- Antenna Parameters with TSL:** The dipole is mounted with the spacer to position its feed point exactly below the center marking of the flat phantom section, with the arms oriented parallel to the body axis.
- Feed Point Impedance and Return Loss:** These parameters are measured with the dipole positioned under the liquid filled phantom. The impedance stated is transformed from the measurement at the SMA connector to the feed point. The Return Loss ensures low reflected power. No uncertainty required.
- Electrical Delay:** One-way delay between the SMA connector and the antenna feed point. No uncertainty required.
- SAR measured:** SAR measured at the stated antenna input power.
- SAR normalized:** SAR as measured, normalized to an input power of 1 W at the antenna connector.
- SAR for nominal TSL parameters:** The measured TSL parameters are used to calculate the nominal SAR result.

# TA Technology (Shanghai) Co., Ltd.

## Test Report

### Measurement Conditions

DASY system configuration, as far as not given on page 1.

DASY Version	DASY5	V52.6.2
Extrapolation	Advanced Extrapolation	
Phantom	Modular Flat Phantom	
Distance Dipole Center - TSL	15 mm	with Spacer
Zoom Scan Resolution	dx, dy, dz = 5 mm	
Frequency	835 MHz ± 1 MHz	

### Head TSL parameters

The following parameters and calculations were applied.

	Temperature	Permittivity	Conductivity
Nominal Head TSL parameters	22.0 °C	41.5	0.90 mho/m
Measured Head TSL parameters	(22.0 ± 0.2) °C	41.1 ± 6 %	0.89 mho/m ± 6 %
Head TSL temperature change during test	< 0.5 °C	----	----

### SAR result with Head TSL

SAR averaged over 1 cm <sup>3</sup> (1 g) of Head TSL	Condition	
SAR measured	250 mW input power	2.32 mW / g
SAR for nominal Head TSL parameters	normalized to 1W	<b>9.34 mW / g ± 17.0 % (k=2)</b>

SAR averaged over 10 cm <sup>3</sup> (10 g) of Head TSL	condition	
SAR measured	250 mW input power	1.52 mW / g
SAR for nominal Head TSL parameters	normalized to 1W	<b>6.11 mW / g ± 16.5 % (k=2)</b>

### Body TSL parameters

The following parameters and calculations were applied.

	Temperature	Permittivity	Conductivity
Nominal Body TSL parameters	22.0 °C	55.2	0.97 mho/m
Measured Body TSL parameters	(22.0 ± 0.2) °C	53.4 ± 6 %	0.99 mho/m ± 6 %
Body TSL temperature change during test	< 0.5 °C	----	----

### SAR result with Body TSL

SAR averaged over 1 cm <sup>3</sup> (1 g) of Body TSL	Condition	
SAR measured	250 mW input power	2.42 mW / g
SAR for nominal Body TSL parameters	normalized to 1W	<b>9.46 mW / g ± 17.0 % (k=2)</b>

SAR averaged over 10 cm <sup>3</sup> (10 g) of Body TSL	condition	
SAR measured	250 mW input power	1.59 mW / g
SAR for nominal Body TSL parameters	normalized to 1W	<b>6.26 mW / g ± 16.5 % (k=2)</b>

**TA Technology (Shanghai) Co., Ltd.**  
**Test Report**

**Appendix**

**Antenna Parameters with Head TSL**

Impedance, transformed to feed point	52.9 $\Omega$ - 3.1 j $\Omega$
Return Loss	- 27.7 dB

**Antenna Parameters with Body TSL**

Impedance, transformed to feed point	48.7 $\Omega$ - 5.4 j $\Omega$
Return Loss	- 25.1 dB

**General Antenna Parameters and Design**

Electrical Delay (one direction)	1.391 ns
----------------------------------	----------

After long term use with 100W radiated power, only a slight warming of the dipole near the feedpoint can be measured.

The dipole is made of standard semirigid coaxial cable. The center conductor of the feeding line is directly connected to the second arm of the dipole. The antenna is therefore short-circuited for DC-signals.

No excessive force must be applied to the dipole arms, because they might bend or the soldered connections near the feedpoint may be damaged.

**Additional EUT Data**

Manufactured by	SPEAG
Manufactured on	April 22, 2004

**DASY5 Validation Report for Head TSL**

Date: 25.08.2011

Test Laboratory: SPEAG, Zurich, Switzerland

**DUT: Dipole 835 MHz; Type: D835V2; Serial: D835V2 - SN: 4d020**

Communication System: CW; Frequency: 835 MHz

Medium parameters used:  $f = 835 \text{ MHz}$ ;  $\sigma = 0.89 \text{ mho/m}$ ;  $\epsilon_r = 41.1$ ;  $\rho = 1000 \text{ kg/m}^3$

Phantom section: Flat Section

Measurement Standard: DASY5 (IEEE/IEC/ANSI C63.19-2007)

DASY52 Configuration:

- Probe: ES3DV3 - SN3205; ConvF(6.07, 6.07, 6.07); Calibrated: 29.04.2011
- Sensor-Surface: 3mm (Mechanical Surface Detection)
- Electronics: DAE4 Sn601; Calibrated: 04.07.2011
- Phantom: Flat Phantom 4.9L; Type: QD000P49AA; Serial: 1001
- DASY52 52.6.2(482); SEMCAD X 14.4.5(3634)

**Dipole Calibration for Head Tissue/Pin=250 mW, d=15mm/Zoom Scan (7x7x7)/Cube 0:**

Measurement grid: dx=5mm, dy=5mm, dz=5mm

Reference Value = 56.930 V/m; Power Drift = 0.03 dB

Peak SAR (extrapolated) = 3.421 W/kg

**SAR(1 g) = 2.32 mW/g; SAR(10 g) = 1.52 mW/g**

Maximum value of SAR (measured) = 2.708 mW/g

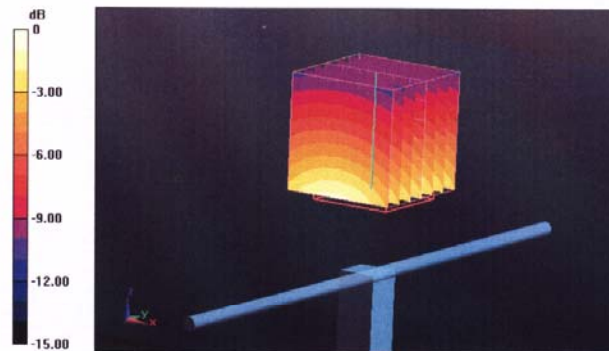

0 dB = 2.710mW/g

# TA Technology (Shanghai) Co., Ltd. Test Report

Report No. RZA1203-0346SAR

Page 70 of 98

## Impedance Measurement Plot for Head TSL

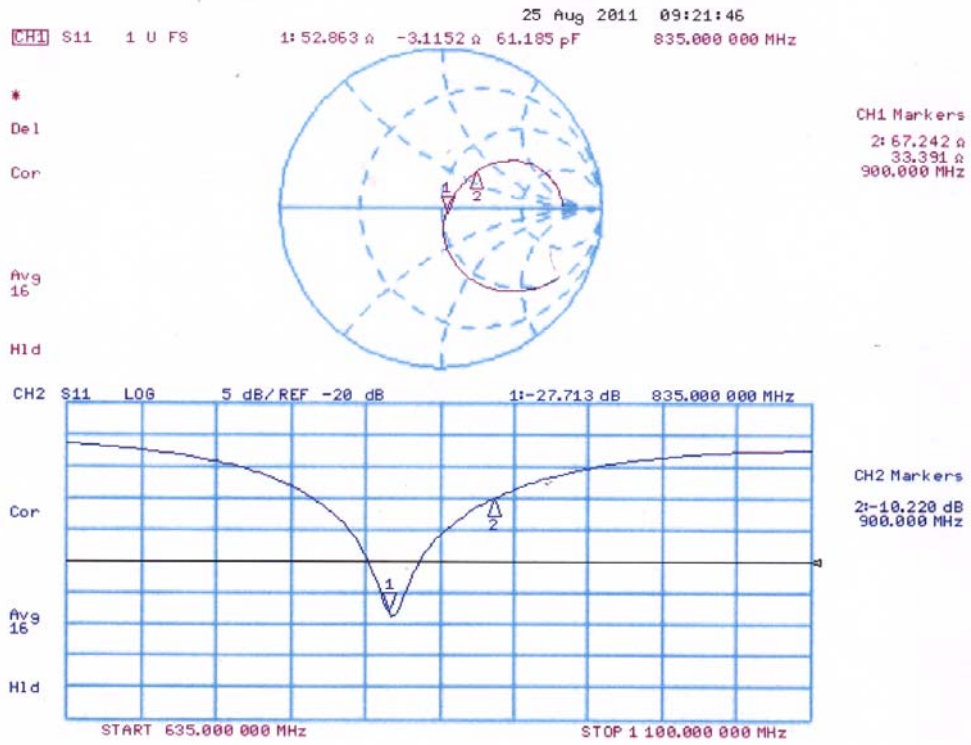

**DASY5 Validation Report for Body TSL**

Date: 26.08.2011

Test Laboratory: SPEAG, Zurich, Switzerland

**DUT: Dipole 835 MHz; Type: D835V2; Serial: D835V2 - SN: 4d020**

Communication System: CW; Frequency: 835 MHz

Medium parameters used:  $f = 835 \text{ MHz}$ ;  $\sigma = 0.99 \text{ mho/m}$ ;  $\epsilon_r = 53.4$ ;  $\rho = 1000 \text{ kg/m}^3$

Phantom section: Flat Section

Measurement Standard: DASY5 (IEEE/IEC/ANSI C63.19-2007)

DASY52 Configuration:

- Probe: ES3DV3 - SN3205; ConvF(6.02, 6.02, 6.02); Calibrated: 29.04.2011
- Sensor-Surface: 3mm (Mechanical Surface Detection)
- Electronics: DAE4 Sn601; Calibrated: 04.07.2011
- Phantom: Flat Phantom 4.9L; Type: QD000P49AA; Serial: 1001
- DASY52 52.6.2(482); SEMCAD X 14.4.5(3634)

**Dipole Calibration for Body Tissue/Pin=250 mW, d=15mm/Zoom Scan (7x7x7)/Cube 0:**

Measurement grid:  $dx=5\text{mm}$ ,  $dy=5\text{mm}$ ,  $dz=5\text{mm}$

Reference Value = 55.406 V/m; Power Drift = 0.02 dB

Peak SAR (extrapolated) = 3.509 W/kg

**SAR(1 g) = 2.42 mW/g; SAR(10 g) = 1.59 mW/g**

Maximum value of SAR (measured) = 2.827 mW/g

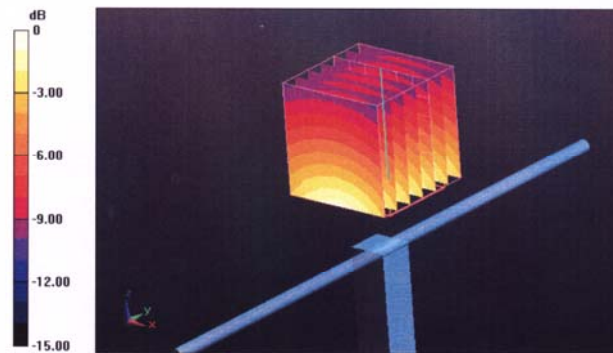

Impedance Measurement Plot for Body TSL

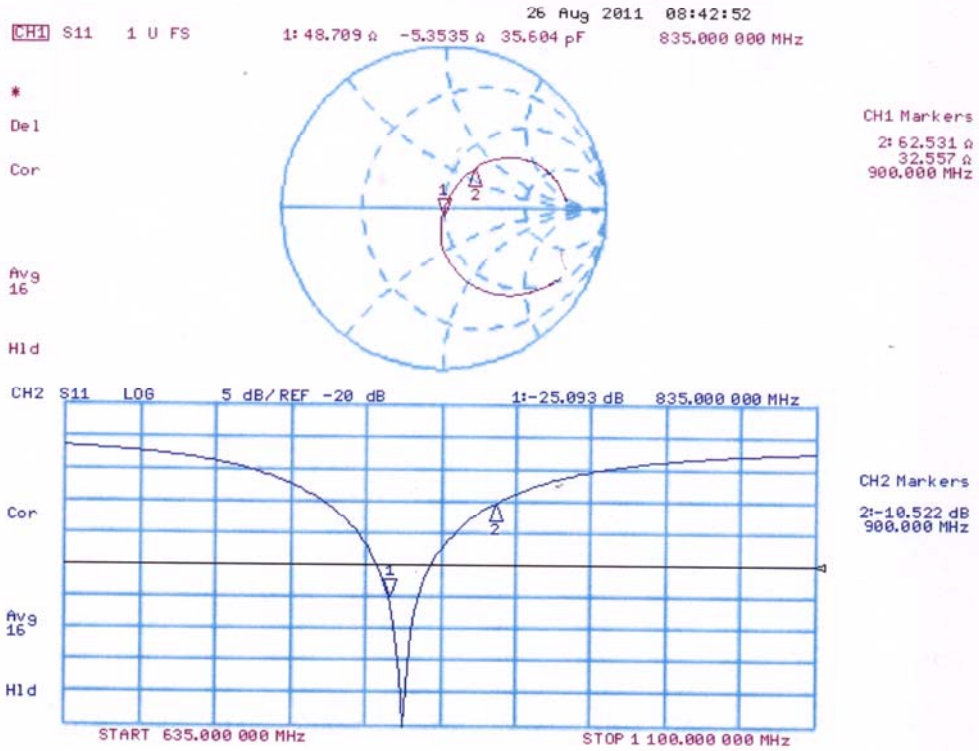



# TA Technology (Shanghai) Co., Ltd.

## Test Report

Report No. RZA1203-0346SAR

Page 73 of 98

### ANNEX F: DAE4 Calibration Certificate

**Calibration Laboratory of  
Schmid & Partner  
Engineering AG**  
Zeughausstrasse 43, 8004 Zurich, Switzerland



**S** Schweizerischer Kalibrierdienst  
**C** Service suisse d'étalonnage  
**S** Servizio svizzero di taratura  
**S** Swiss Calibration Service

Accredited by the Swiss Accreditation Service (SAS)  
The Swiss Accreditation Service is one of the signatories to the EA  
Multilateral Agreement for the recognition of calibration certificates

Accreditation No.: **SCS 108**

Client **TA-SH (Auden)**

Certificate No: **DAE4-871\_Nov11**

CALIBRATION CERTIFICATE																			
Object	DAE4 - SD 000 D04 BJ - SN: 871																		
Calibration procedure(s)	QA CAL-06.v23 Calibration procedure for the data acquisition electronics (DAE)																		
Calibration date:	November 22, 2011																		
<p>This calibration certificate documents the traceability to national standards, which realize the physical units of measurements (SI). The measurements and the uncertainties with confidence probability are given on the following pages and are part of the certificate.</p> <p>All calibrations have been conducted in the closed laboratory facility; environment temperature (22 ± 3)°C and humidity &lt; 70%.</p> <p>Calibration Equipment used (M&amp;TE critical for calibration)</p> <table border="1" style="width: 100%; border-collapse: collapse;"> <thead> <tr> <th style="width: 30%;">Primary Standards</th> <th style="width: 15%;">ID #</th> <th style="width: 30%;">Cal Date (Certificate No.)</th> <th style="width: 25%;">Scheduled Calibration</th> </tr> </thead> <tbody> <tr> <td>Keithley Multimeter Type 2001</td> <td>SN: 0810278</td> <td>28-Sep-11 (No:11450)</td> <td>Sep-12</td> </tr> <tr> <th>Secondary Standards</th> <th>ID #</th> <th>Check Date (in house)</th> <th>Scheduled Check</th> </tr> <tr> <td>Calibrator Box V1.1</td> <td>SE UMS 006 AB 1004</td> <td>08-Jun-11 (in house check)</td> <td>In house check: Jun-12</td> </tr> </tbody> </table>				Primary Standards	ID #	Cal Date (Certificate No.)	Scheduled Calibration	Keithley Multimeter Type 2001	SN: 0810278	28-Sep-11 (No:11450)	Sep-12	Secondary Standards	ID #	Check Date (in house)	Scheduled Check	Calibrator Box V1.1	SE UMS 006 AB 1004	08-Jun-11 (in house check)	In house check: Jun-12
Primary Standards	ID #	Cal Date (Certificate No.)	Scheduled Calibration																
Keithley Multimeter Type 2001	SN: 0810278	28-Sep-11 (No:11450)	Sep-12																
Secondary Standards	ID #	Check Date (in house)	Scheduled Check																
Calibrator Box V1.1	SE UMS 006 AB 1004	08-Jun-11 (in house check)	In house check: Jun-12																
Calibrated by:	Name Andrea Gunti	Function Technician	Signature 																
Approved by:	Fin Bornholt	R&D Director																	
			Issued: November 22, 2011																
This calibration certificate shall not be reproduced except in full without written approval of the laboratory.																			

**Calibration Laboratory of  
Schmid & Partner  
Engineering AG**  
Zeughausstrasse 43, 8004 Zurich, Switzerland



**S** Schweizerischer Kalibrierdienst  
**C** Service suisse d'étalonnage  
**S** Servizio svizzero di taratura  
**S** Swiss Calibration Service

Accredited by the Swiss Accreditation Service (SAS)  
The Swiss Accreditation Service is one of the signatories to the EA  
Multilateral Agreement for the recognition of calibration certificates

Accreditation No.: **SCS 108**

### Glossary

DAE data acquisition electronics  
Connector angle information used in DASY system to align probe sensor X to the robot coordinate system.

### Methods Applied and Interpretation of Parameters

- **DC Voltage Measurement:** Calibration Factor assessed for use in DASY system by comparison with a calibrated instrument traceable to national standards. The figure given corresponds to the full scale range of the voltmeter in the respective range.
- **Connector angle:** The angle of the connector is assessed measuring the angle mechanically by a tool inserted. Uncertainty is not required.
- The following parameters as documented in the Appendix contain technical information as a result from the performance test and require no uncertainty.
  - **DC Voltage Measurement Linearity:** Verification of the Linearity at +10% and -10% of the nominal calibration voltage. Influence of offset voltage is included in this measurement.
  - **Common mode sensitivity:** Influence of a positive or negative common mode voltage on the differential measurement.
  - **Channel separation:** Influence of a voltage on the neighbor channels not subject to an input voltage.
  - **AD Converter Values with inputs shorted:** Values on the internal AD converter corresponding to zero input voltage
  - **Input Offset Measurement:** Output voltage and statistical results over a large number of zero voltage measurements.
  - **Input Offset Current:** Typical value for information; Maximum channel input offset current, not considering the input resistance.
  - **Input resistance:** Typical value for information: DAE input resistance at the connector, during internal auto-zeroing and during measurement.
  - **Low Battery Alarm Voltage:** Typical value for information. Below this voltage, a battery alarm signal is generated.
  - **Power consumption:** Typical value for information. Supply currents in various operating modes.

# TA Technology (Shanghai) Co., Ltd.

## Test Report

Report No. RZA1203-0346SAR

Page 75 of 98

### DC Voltage Measurement

A/D - Converter Resolution nominal

High Range: 1LSB = 6.1 $\mu$ V, full range = -100...+300 mV

Low Range: 1LSB = 61nV, full range = -1.....+3mV

DASY measurement parameters: Auto Zero Time: 3 sec; Measuring time: 3 sec

Calibration Factors	X	Y	Z
High Range	404.749 $\pm$ 0.1% (k=2)	404.733 $\pm$ 0.1% (k=2)	405.174 $\pm$ 0.1% (k=2)
Low Range	3.98175 $\pm$ 0.7% (k=2)	3.93601 $\pm$ 0.7% (k=2)	3.96830 $\pm$ 0.7% (k=2)

### Connector Angle

Connector Angle to be used in DASY system	90.0 $\pm$ 1 $^{\circ}$
---	-------------------------

# TA Technology (Shanghai) Co., Ltd.

## Test Report

### Appendix

#### 1. DC Voltage Linearity

High Range	Reading ( $\mu\text{V}$ )	Difference ( $\mu\text{V}$ )	Error (%)
Channel X + Input	199991.9	-0.91	-0.00
Channel X + Input	20000.28	0.48	0.00
Channel X - Input	-19998.51	0.59	-0.00
Channel Y + Input	200003.0	1.24	0.00
Channel Y + Input	19999.67	0.17	0.00
Channel Y - Input	-20000.04	-0.34	0.00
Channel Z + Input	200010.1	-0.11	-0.00
Channel Z + Input	19999.33	-0.07	-0.00
Channel Z - Input	-20001.45	-0.85	0.00

Low Range	Reading ( $\mu\text{V}$ )	Difference ( $\mu\text{V}$ )	Error (%)
Channel X + Input	2000.0	0.05	0.00
Channel X + Input	199.81	-0.09	-0.04
Channel X - Input	-199.63	0.37	-0.19
Channel Y + Input	1999.9	-0.22	-0.01
Channel Y + Input	198.81	-1.19	-0.59
Channel Y - Input	-201.62	-1.72	0.86
Channel Z + Input	2000.4	0.48	0.02
Channel Z + Input	199.30	-0.70	-0.35
Channel Z - Input	-200.86	-1.06	0.53

#### 2. Common mode sensitivity

DASY measurement parameters: Auto Zero Time: 3 sec; Measuring time: 3 sec

	Common mode Input Voltage (mV)	High Range Average Reading ( $\mu\text{V}$ )	Low Range Average Reading ( $\mu\text{V}$ )
Channel X	200	14.43	13.13
	-200	-12.22	-13.72
Channel Y	200	-10.07	-9.78
	-200	9.61	8.66
Channel Z	200	-0.56	-0.83
	-200	-0.01	0.11

#### 3. Channel separation

DASY measurement parameters: Auto Zero Time: 3 sec; Measuring time: 3 sec

	Input Voltage (mV)	Channel X ( $\mu\text{V}$ )	Channel Y ( $\mu\text{V}$ )	Channel Z ( $\mu\text{V}$ )
Channel X	200	-	3.08	0.09
Channel Y	200	3.19	-	4.59
Channel Z	200	0.90	-0.06	-

# TA Technology (Shanghai) Co., Ltd.

## Test Report

#### 4. AD-Converter Values with inputs shorted

DASY measurement parameters: Auto Zero Time: 3 sec; Measuring time: 3 sec

	High Range (LSB)	Low Range (LSB)
Channel X	15920	15519
Channel Y	16179	17567
Channel Z	15791	15270

#### 5. Input Offset Measurement

DASY measurement parameters: Auto Zero Time: 3 sec; Measuring time: 3 sec  
Input 10M $\Omega$

	Average ( $\mu$ V)	min. Offset ( $\mu$ V)	max. Offset ( $\mu$ V)	Std. Deviation ( $\mu$ V)
Channel X	0.03	-1.16	2.66	0.46
Channel Y	-0.63	-3.22	0.29	0.46
Channel Z	-0.87	-2.03	0.28	0.46

#### 6. Input Offset Current

Nominal Input circuitry offset current on all channels: <25fA

#### 7. Input Resistance (Typical values for information)

	Zeroing (kOhm)	Measuring (MOhm)
Channel X	200	200
Channel Y	200	200
Channel Z	200	200

#### 8. Low Battery Alarm Voltage (Typical values for information)

Typical values	Alarm Level (VDC)
Supply (+ Vcc)	+7.9
Supply (- Vcc)	-7.6

#### 9. Power Consumption (Typical values for information)

Typical values	Switched off (mA)	Stand by (mA)	Transmitting (mA)
Supply (+ Vcc)	+0.01	+6	+14
Supply (- Vcc)	-0.01	-8	-9

**ANNEX G: The EUT Appearances and Test Configuration**



Picture 3-1: EUT

TA Technology (Shanghai) Co., Ltd.  
Test Report



Picture 3-2: Thicker Battery

TA Technology (Shanghai) Co., Ltd.  
Test Report



Picture 3-3: Thinner Battery





Picture 3-4: Belt

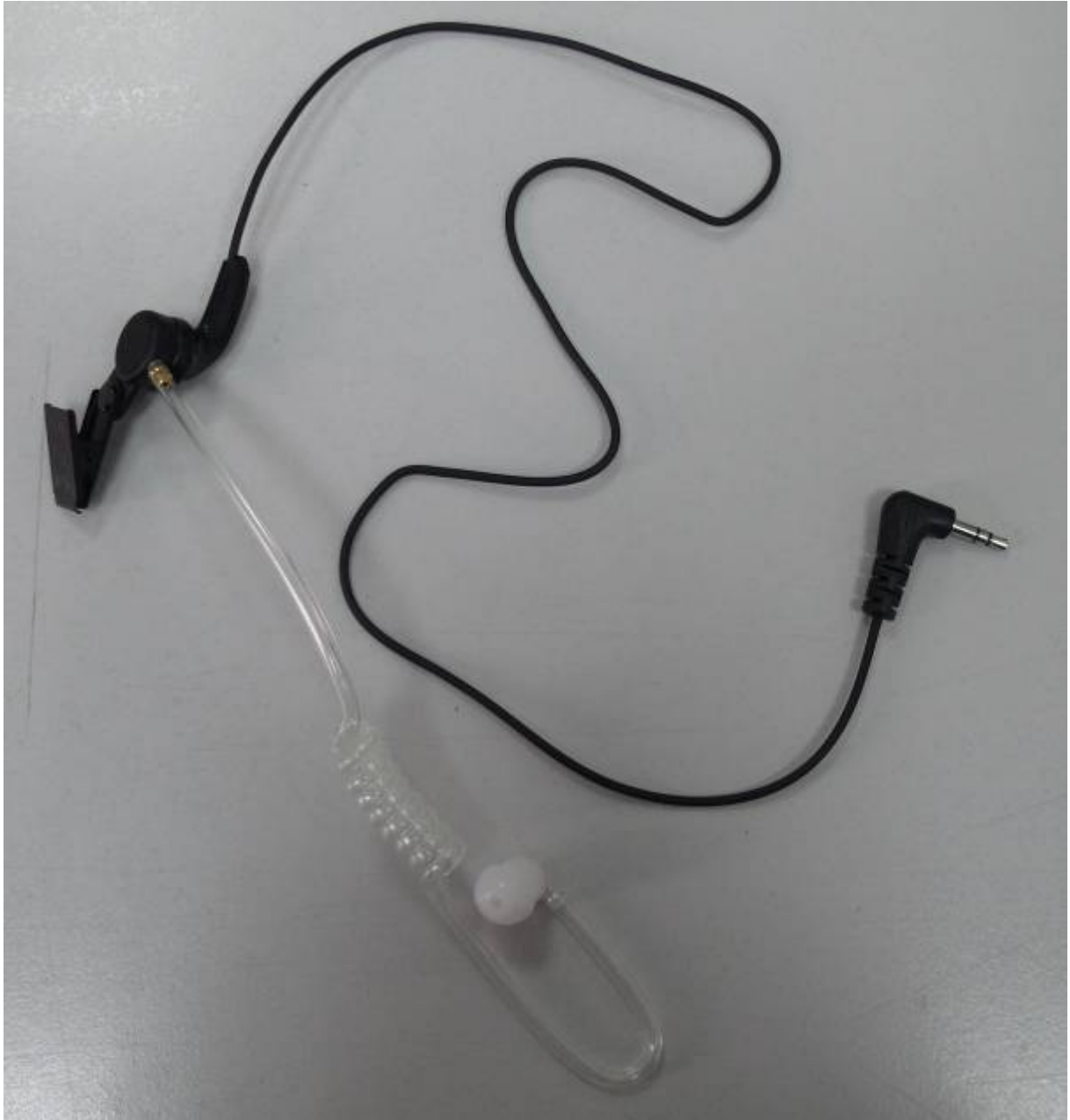

Picture 3-5: Earphone 1



Picture 3-6: Earphone 2

TA Technology (Shanghai) Co., Ltd.  
Test Report

Report No. RZA1203-0346SAR

Page 84 of 98



Picture 3-7: Pocket and Leather



Picture 3-8: Accessory 1

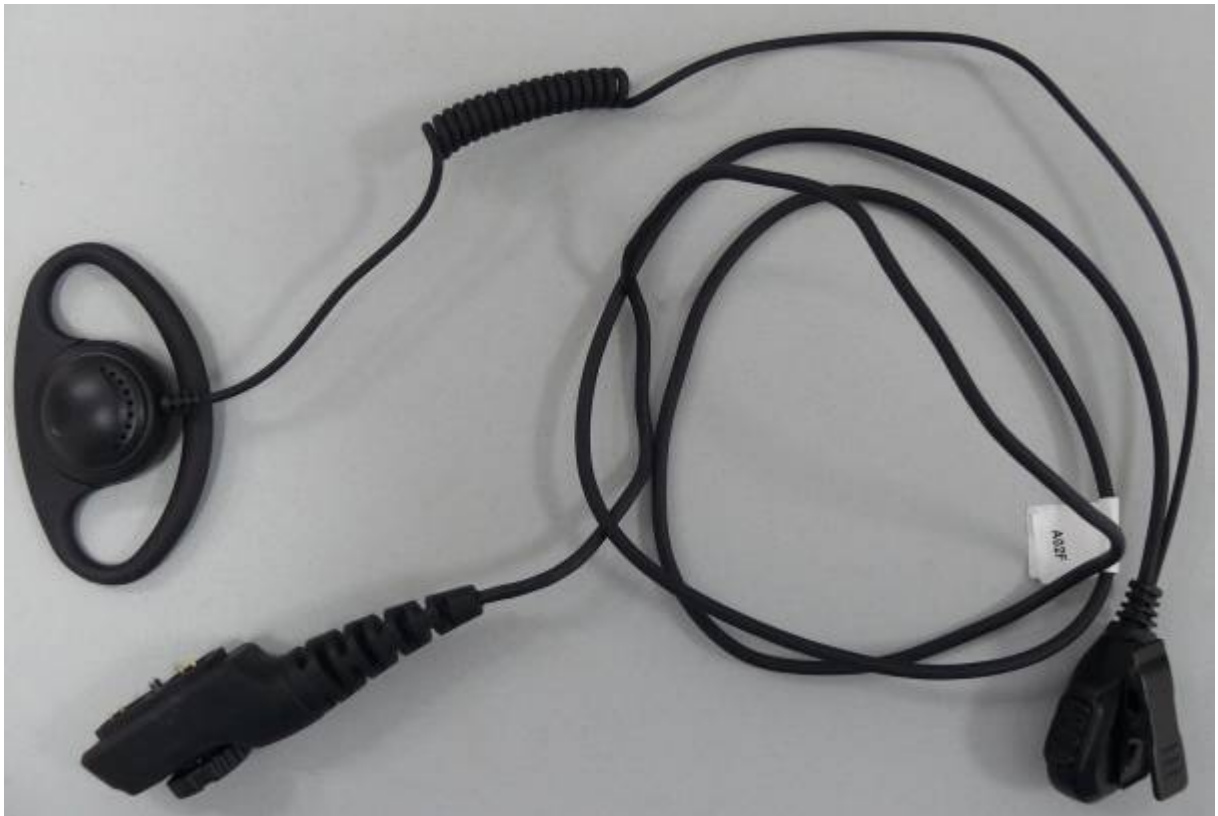

Picture 3-9: Audio Accessory 2



Picture 3-10: Audio Accessory 3



Picture 3-11: Audio Accessory 4



Picture 3-12: Audio Accessory 5

Picture 3: Constituents of the sample

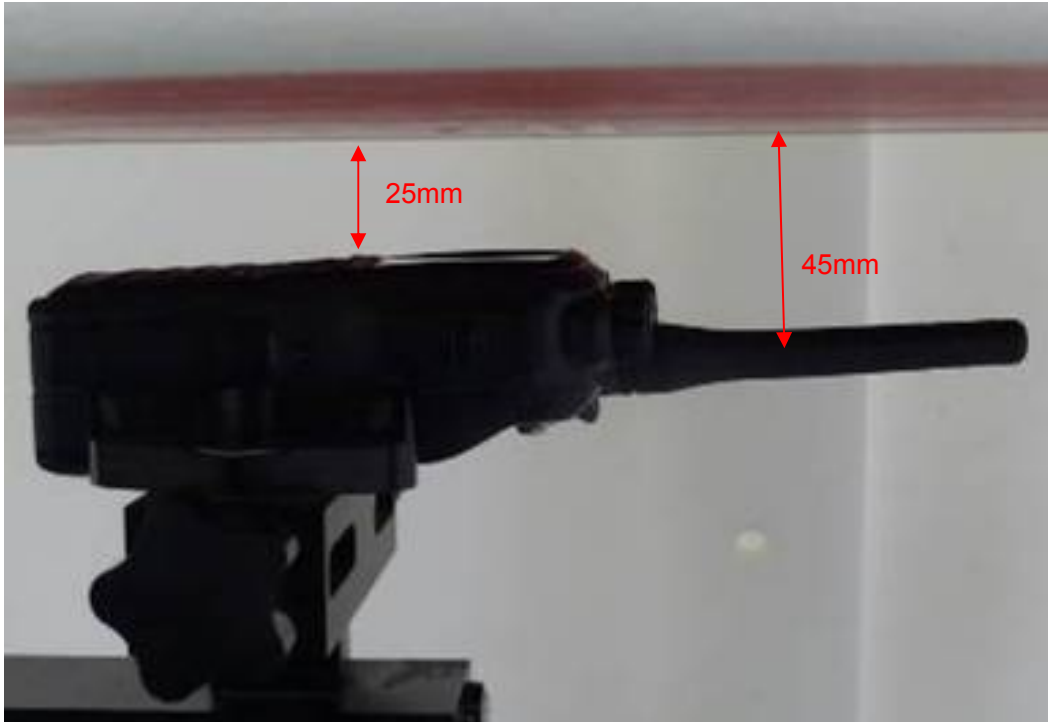

Picture 4: Face-held with Thicker Battery, the front of the EUT towards phantom, the distance from EUT Antenna to the bottom of the Phantom is 45mm

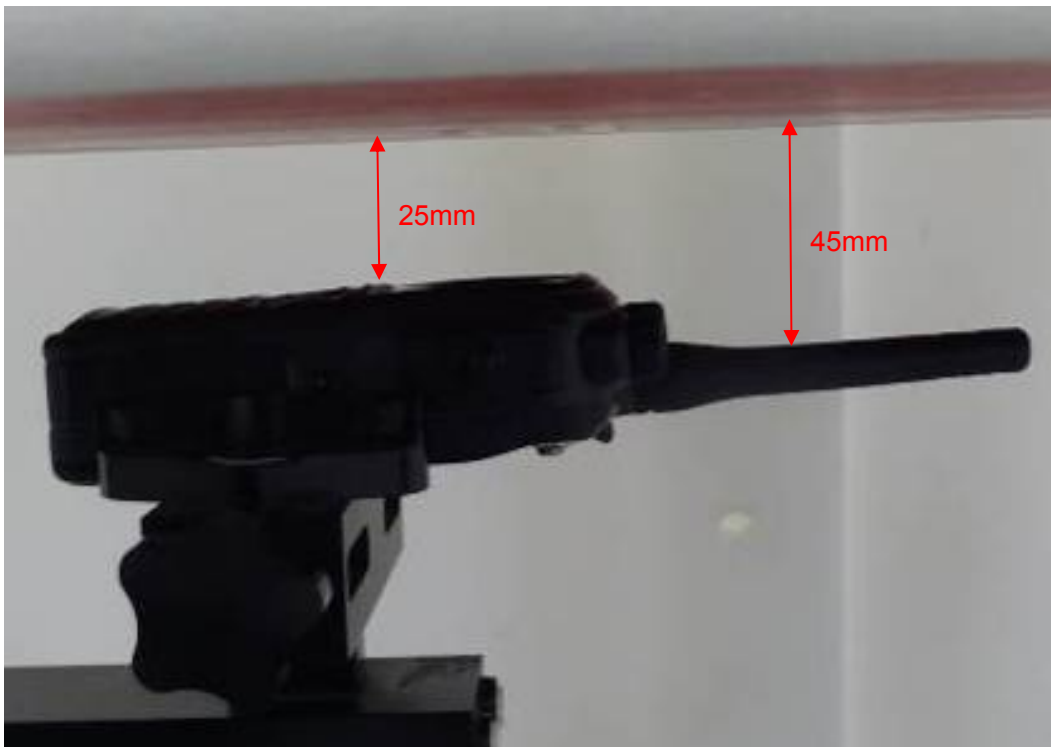

Picture 5: Face-held with Thinner Battery, the front of the EUT towards phantom, the distance from EUT Antenna to the bottom of the Phantom is 45mm





Picture 6: Body-worn with Thinner Battery, Belt and Accessory 1, the front of the EUT towards ground, the distance from EUT Antenna to the bottom of the Phantom is 26mm



Picture 7: Body-worn with Thinner Battery, Belt, Accessory 1 and Earphone 1, the front of the EUT towards ground, the distance from EUT Antenna to the bottom of the Phantom is 26mm

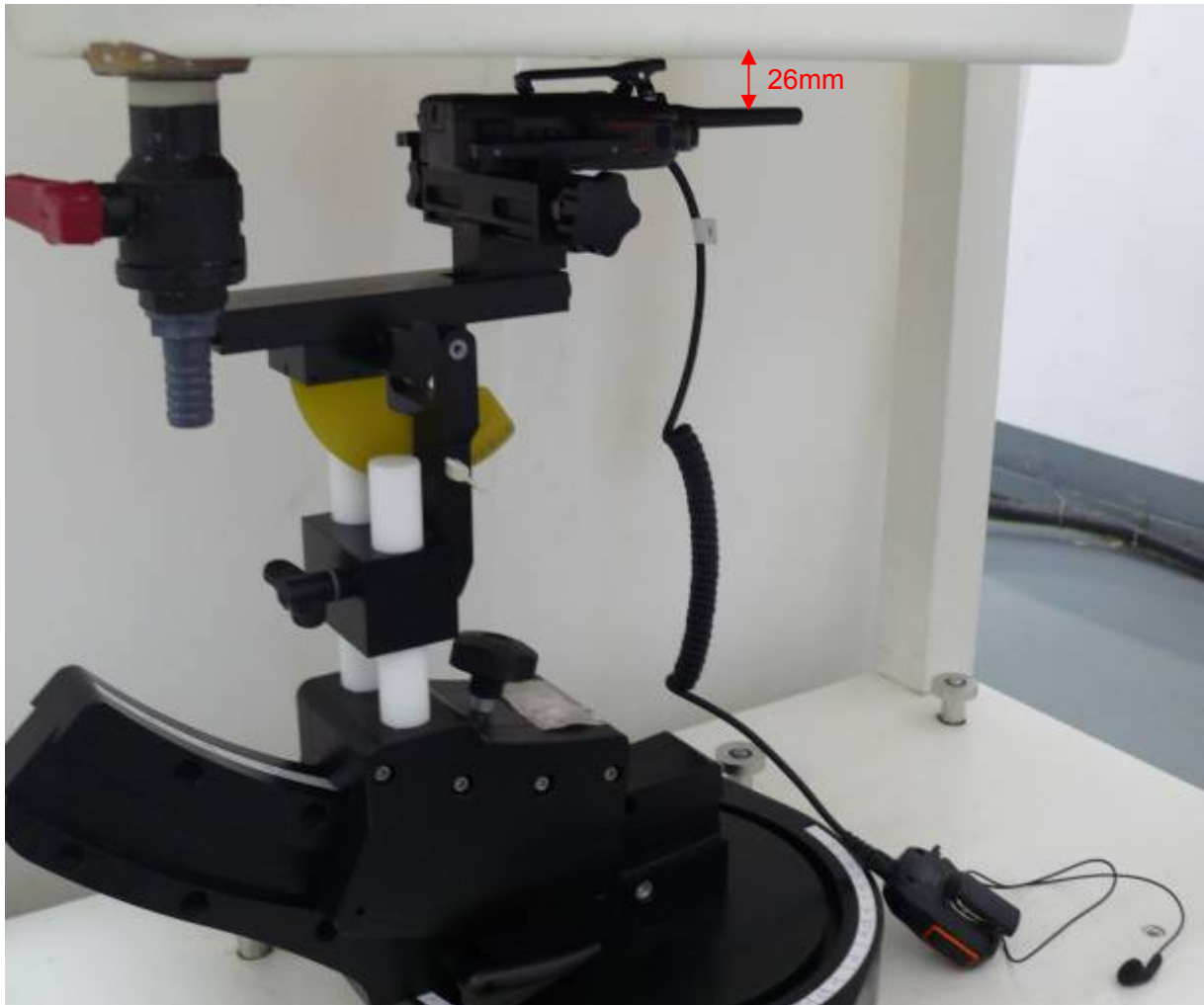

Picture 8: Body-worn with Thinner Battery, Belt, Accessory 1 and Earphone 2, the front of the EUT towards ground, the distance from EUT Antenna to the bottom of the Phantom is 26mm



Picture 9: Body-worn with Thinner Battery, Belt and Audio Accessory 2, the front of the EUT towards ground, the distance from EUT Antenna to the bottom of the Phantom is 26mm



Picture 10: Body-worn with Thinner Battery, Belt and Audio Accessory 3, the front of the EUT towards ground, the distance from EUT Antenna to the bottom of the Phantom is 26mm



Picture 11: Body-worn with Thinner Battery, Belt and Audio Accessory 4, the front of the EUT towards ground, the distance from EUT Antenna to the bottom of the Phantom is 26mm



Picture 12: Body-worn with Thinner Battery, Belt and Audio Accessory 5, the front of the EUT towards ground, the distance from EUT Antenna to the bottom of the Phantom is 26mm



Picture 13: Body-worn with Thinner Battery, Pocket and Accessory 1, the front of the EUT towards ground, the distance from EUT Antenna to the bottom of the Phantom is 26mm





Picture 13: Body-worn with Thinner Battery, Pocket, Leather and Accessory 1, the front of the EUT towards ground, the distance from EUT Antenna to the bottom of the Phantom is 37mm



Picture 14: Body-worn with Thicker Battery, Belt and Accessory 1, the front of the EUT towards ground, the distance from EUT Antenna to the bottom of the Phantom is 24mm