



OET 65

TEST REPORT

Product Name	Digital Portable Radio
Model	PD702G U(1)
FCC ID	YAMPD70XG-U1
Client	Hytera Communications Co.,Ltd.

TA Technology (Shanghai) Co., Ltd.

TA Technology (Shanghai) Co., Ltd.
Test Report

Report No. RZA1203-0315SAR

Page 2 of 100

GENERAL SUMMARY

Product Name	Digital Portable Radio	Model	PD702G U(1)
FCC ID	YAMPD70XG-U1	Report No.	RZA1203-0315SAR
Client	Hytera Communications Co.,Ltd.		
Manufacturer	Hytera Communications Co.,Ltd.		
Reference Standard(s)	<p>IEEE Std C95.1, 1999: IEEE Standard for Safety Levels with Respect to Human Exposure to Radio Frequency Electromagnetic Fields, 3 KHz to 300 GHz.</p> <p>IEEE Std 1528™-2003: IEEE Recommended Practice for Determining the Peak Spatial-Average Specific Absorption Rate (SAR) in the Human Head from Wireless Communications Devices: Measurement Techniques.</p> <p>SUPPLEMENT C Edition 01-01 to OET BULLETIN 65 Edition 97-01 June 2001 including DA 02-1438 June 19, 2002: Evaluating Compliance with FCC Guidelines for Human Exposure to Radiofrequency Electromagnetic Fields Additional Information for Evaluation Compliance of Mobile and Portable Devices with FCC Limits for Human Exposure to Radiofrequency Emissions.</p> <p>KDB 643646 D01 SAR Test for PTT Radios v01: SAR Test Reduction Considerations for Occupational PTT Radios</p> <p>KDB 447498 D01 Mobile Portable RF Exposure v04: Mobile and Portable Device RF Exposure Procedures and Equipment Authorization Policies</p>		
Conclusion	<p>This portable wireless equipment has been measured in all cases requested by the relevant standards. Test results in Chapter 7 of this test report are below limits specified in the relevant standards.</p> <p>General Judgment: Pass</p> <p style="text-align: right;">(Stamp) Date of issue: March 31st, 2012</p>		
Comment	The test result only responds to the measured sample.		



Approved by 杨伟中
Director

Revised by 凌敏宝
SAR Manager

Performed by 杨如荷
SAR Engineer

TABLE OF CONTENT

1. General Information	5
1.1. Notes of the Test Report.....	5
1.2. Testing Laboratory	5
1.3. Applicant Information	6
1.4. Manufacturer Information.....	6
1.5. Information of EUT.....	7
1.6. The Maximum SAR _{1g} Values	9
1.7. Test Date	9
2. SAR Measurements System Configuration.....	10
2.1. SAR Measurement Set-up.....	10
2.2. DASY4 E-field Probe System	11
2.2.1. EX3DV4 Probe Specification	11
2.2.2. E-field Probe Calibration.....	12
2.3. Other Test Equipment	12
2.3.1. Device Holder for Transmitters	12
2.3.2. Phantom	13
2.4. Scanning Procedure	13
2.5. Data Storage and Evaluation	15
2.5.1. Data Storage.....	15
2.5.2. Data Evaluation by SEMCAD	15
3. Laboratory Environment.....	17
4. Tissue-equivalent Liquid	18
4.1. Tissue-equivalent Liquid Ingredients.....	18
4.2. Tissue-equivalent Liquid Properties	19
5. System Check.....	20
5.1. Description of System Check.....	20
5.2. System Check Results.....	22
6. Operational Conditions during Test.....	23
6.1. General Description of Test Procedures	23
6.2. Test Configuration	23
6.2.1. Face-Held Configuration.....	23
6.2.2. Body-Worn Configuration	23
7. Test Results	24
7.1. Conducted Power Results	24
7.2. SAR Test Results	25
6. Measurement Uncertainty.....	29
7. Main Test Instruments.....	31
ANNEX A: Test Layout	32
ANNEX B: System Check Results	33

TA Technology (Shanghai) Co., Ltd.
Test Report

Report No. RZA1203-0315SAR

Page 4 of 100

ANNEX C: Graph Results	35
ANNEX D: Probe Calibration Certificate	54
ANNEX E: D450V3 Dipole Calibration Certificate	65
ANNEX F: DAE4 Calibration Certificate	74
ANNEX G: The EUT Appearances and Test Configuration	79

1. General Information

1.1. Notes of the Test Report

TA Technology (Shanghai) Co., Ltd. guarantees the reliability of the data presented in this test report, which is the results of measurements and tests performed for the items under test on the date and under the conditions stated in this test report and is based on the knowledge and technical facilities available at TA Technology (Shanghai) Co., Ltd. at the time of execution of the test.

TA Technology (Shanghai) Co., Ltd. is liable to the client for the maintenance by its personnel of the confidentiality of all information related to the items under test and the results of the test. This report only refers to the item that has undergone the test.

This report standalone dose not constitute or imply by its own an approval of the product by the certification Bodies or competent Authorities. This report cannot be used partially or in full for publicity and/or promotional purposes without previous written approval of **TA Technology (Shanghai) Co., Ltd.** and the Accreditation Bodies, if it applies.

If the electrical report is inconsistent with the printed one, it should be subject to the latter.

1.2. Testing Laboratory

Company: TA Technology (Shanghai) Co., Ltd.
Address: No.145, Jintang Rd, Tangzhen Industry Park, Pudong Shanghai, China
City: Shanghai
Post code: 201201
Country: P. R. China
Contact: Yang Weizhong
Telephone: +86-021-50791141/2/3
Fax: +86-021-50791141/2/3-8000
Website: <http://www.ta-shanghai.com>
E-mail: yangweizhong@ta-shanghai.com

TA Technology (Shanghai) Co., Ltd.

Test Report

Report No. RZA1203-0315SAR

Page 6 of 100

1.3. Applicant Information

Company: Hytera Communications Co.,Ltd.
Address: Hytera Tower,Hi-Tech Industrial Park North, Nanshan District,Shenzhen China
City: Shenzhen
Postal Code: 518057
Country: P. R. China
Telephone: +86-0755-26972999- 1210
Fax: +86 755 86137130

1.4. Manufacturer Information

Company: Hytera Communications Co.,Ltd.
Address: Hytera Tower,Hi-Tech Industrial Park North, Nanshan District,Shenzhen China
City: Shenzhen
Postal Code: 518057
Country: P. R. China
Telephone: +86-0755-26972999- 1210
Fax: 0755-86137130

TA Technology (Shanghai) Co., Ltd.
Test Report

Report No. RZA1203-0315SAR

Page 7 of 100

1.5. Information of EUT

General Information

Device Type:	Portable Device
Exposure Category:	Controlled Environment /Occupational
State of Sample:	Prototype Unit
Product Name:	Digital Portable Radio
SN:	/
Hardware Version:	41PD7001000HO
Software Version:	A4.00.10.001
Antenna Type:	External Antenna
Device Operating Configurations:	
Test Modulation:	FM (Analog), 4FSK(Digital)
Operating Frequency Range(s):	400.5 MHz ~469.5 MHz(UHF)
Test Frequency:	400.5 MHz – 418MHz – 435.5MHz – 452.5MHz – 469.5MHz
Note: 1. The test channels were selected in accordance with the procedures specified in FCC KDB 447498 D01 Mobile Portable RF Exposure v04 Section 6) c).	

TA Technology (Shanghai) Co., Ltd.

Test Report

Report No. RZA1203-0315SAR

Page 8 of 100

Auxiliary Equipment Details

Accessory Name for Test Report	Model	Description	Manufacturer	
Battery			Hytera Communications Co.,Ltd.	
Thicker Battery	BL2503	Battery,Li-Ion 2500 mAh,DMR		
Thinner Battery	BL2006	Battery,Li-Ion 2000 mAh,DMR		
Body-worn				
Belt	BC19	Belt Clip,DMR		
Pocket	LCY003	Case, leather w/Swivel,DMR		
Chest Pack1	LCBN13	Belt Clip		
Audio				
Earphone 1	ESS07	Earbud,Receive Only,DMR		
Earphone 2	ESS08	Earpiece,Receive Only,DMR		
Accessory 1	SM18N2	Speaker Mic, Water-Proof Remote,DMR		
Audio Accessory 2	EHN12	D-Earset, w/ In-Line Mic and PTT,DMR		
Audio Accessory 3	EAN16	Earpiece, w/ On-Mic PTT,DMR		
Audio Accessory 4	EAN18	Earpiece, 3-wire Surveillance Kit,DMR		
Audio Accessory 5	ESN10	Earbud, w/ On-Mic PTT,DMR		
<p>Note 1. The Chest Pack provide an extra protection to the operator under RF exposure due to special measures taken during design and manufacturing process. Chest Pack is designed allow the radio only stick to it with belt-clip, the belt-clip will provide necessary distance between antenna and operator's body. The operator should follow Chest Pack usage instruction to ensure compliance with RF energy exposure limits. According to OET 65C, when multiple accessories that don't contain metallic components are supplied with the device, the device may be tested with only the accessory that dictates the closest spacing to the body. Because the spacing of combination Chest Pack and belt-clip is higher than only belt-clip, SAR is not required for combination Chest Pack and belt-clip state.</p>				

Equipment Under Test (EUT) is a Digital Portable Radio. SAR is tested for 400.5 - 469.5 MHz only. The EUT has one external antenna that is used for Tx/Rx.

The sample undergoing test was selected by the Client.

Components list please refer to documents of the manufacturer.

TA Technology (Shanghai) Co., Ltd.
Test Report

Report No. RZA1203-0315SAR

Page 9 of 100

1.6. The Maximum SAR_{1g} Values

Mode	Frequency (MHz)	Position	SAR _{1g} (W/kg) 50% PTT duty cycle
UHF	418	Face-held	2.655
UHF	400.5	Body-Worn	4.407

1.7. Test Date

The test performed on March 23, 2012.

2. SAR Measurements System Configuration

2.1. SAR Measurement Set-up

The DASY4 system for performing compliance tests consists of the following items:

- A standard high precision 6-axis robot (Stäubli RX family) with controller and software. An arm extension for accommodating the data acquisition electronics (DAE).
- A dosimetric probe, i.e. an isotropic E-field probe optimized and calibrated for usage in tissue simulating liquid. The probe is equipped with an optical surface detector system.
- A data acquisition electronic (DAE) which performs the signal amplification, signal multiplexing, AD-conversion, offset measurements, mechanical surface detection, collision detection, etc. The unit is battery powered with standard or rechargeable batteries. The signal is optically transmitted to the EOC.
- A unit to operate the optical surface detector which is connected to the EOC.
- The Electro-Optical Coupler (EOC) performs the conversion from the optical into a digital electric signal of the DAE. The EOC is connected to the DASY4 measurement server.
- The DASY4 measurement server, which performs all real-time data evaluation for field measurements and surface detection, controls robot movements and handles safety operation. A computer operating Windows 2003
- DASY4 software and SEMCAD data evaluation software.
- Remote control with teach panel and additional circuitry for robot safety such as warning lamps, etc.
- The generic twin phantom enabling the testing of left-hand and right-hand usage.
- The device holder for handheld mobile phones.
- Tissue simulating liquid mixed according to the given recipes.
- System validation dipoles allowing to validate the proper functioning of the system.

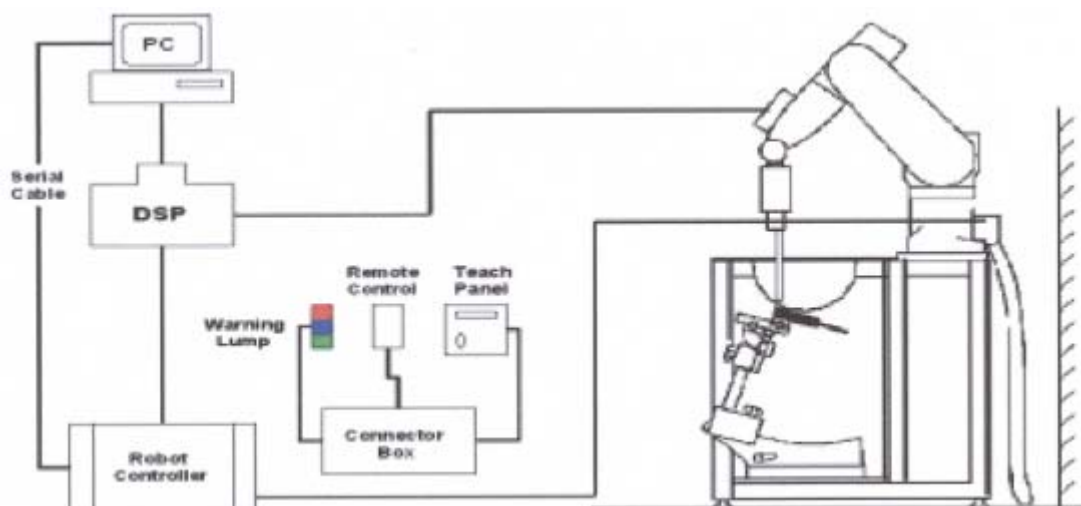

Figure 1. SAR Lab Test Measurement Set-up

2.2. DASY4 E-field Probe System

The SAR measurements were conducted with the dosimetric probe EX3DV4 (manufactured by SPEAG), designed in the classical triangular configuration and optimized for dosimetric evaluation.

2.2.1. EX3DV4 Probe Specification

Construction	Symmetrical design with triangular core Built-in shielding against static charges PEEK enclosure material (resistant to organic solvents, e.g., DGBE)
Calibration	ISO/IEC 17025 calibration service available
Frequency	10 MHz to > 6 GHz Linearity: ± 0.2 dB (30 MHz to 6 GHz)
Directivity	± 0.3 dB in HSL (rotation around probe axis) ± 0.5 dB in tissue material (rotation normal to probe axis)
Dynamic Range	10 μ W/g to > 100 mW/g Linearity: ± 0.2 dB (noise: typically < 1 μ W/g)
Dimensions	Overall length: 330 mm (Tip: 20 mm) Tip diameter: 2.5 mm (Body: 12 mm) Typical distance from probe tip to dipole centers: 1 mm
Application	High precision dosimetric measurements in any exposure scenario (e.g., very strong gradient fields). Only probe which enables compliance testing for frequencies up to 6 GHz with precision of better 30%.



Figure 2. EX3DV4 E-field Probe



Figure 3. EX3DV4 E-field probe

2.2.2. E-field Probe Calibration

Each probe is calibrated according to a dosimetric assessment procedure with accuracy better than $\pm 10\%$. The spherical isotropy was evaluated and found to be better than $\pm 0.25\text{dB}$. The sensitivity parameters (NormX, NormY, NormZ), the diode compression parameter (DCP) and the conversion factor (ConvF) of the probe are tested.

The free space E-field from amplified probe outputs is determined in a test chamber. This is performed in a TEM cell for frequencies below 1 GHz, and in a wave guide above 1 GHz for free space. For the free space calibration, the probe is placed in the volumetric center of the cavity and at the proper orientation with the field. The probe is then rotated 360 degrees.

E-field temperature correlation calibration is performed in a flat phantom filled with the appropriate simulated brain tissue. The measured free space E-field in the medium correlates to temperature rise in a dielectric medium. For temperature correlation calibration a RF transparent thermistor-based temperature probe is used in conjunction with the E-field probe.

$$\text{SAR} = C \frac{\Delta T}{\Delta t}$$

Where: Δt = Exposure time (30 seconds),
C = Heat capacity of tissue (brain or muscle),
 ΔT = Temperature increase due to RF exposure.
Or

$$\text{SAR} = \frac{|E|^2 \sigma}{\rho}$$

Where:
 σ = Simulated tissue conductivity,
 ρ = Tissue density (kg/m³).

2.3. Other Test Equipment

2.3.1. Device Holder for Transmitters

The DASY device holder is designed to cope with the different positions given in the standard.

It has two scales for device rotation (with respect to the body axis) and device inclination (with respect to the line between the ear reference points). The rotation centers for both scales is the ear reference point (ERP). Thus the device needs no repositioning when changing the angles.

The DASY device holder is constructed of low-loss POM material. The amount of dielectric material

has been reduced in the closest vicinity of the device, since measurements have suggested that the inference of the clamp on the test results could thus be lowered.



Figure 4. Device Holder

2.3.2. Phantom

Phantom for compliance testing of handheld and body-mounted wireless devices in the frequency range of 30 MHz to 6 GHz. ELI is fully compatible with the IEC 62209-2 standard and all known tissue-simulating liquids. ELI has been optimized regarding its performance and can be integrated into our standard phantom tables. A cover prevents evaporation of the liquid. Reference markings on the phantom allow installation of the complete setup, including all predefined phantom positions and measurement grids, by teaching three points. The phantom is compatible with all SPEAG dosimetric probes and dipoles.

Shell Thickness	2±0.2 mm
Filling Volume	Approx. 30 liters
Dimensions	190×600×0 mm (H x L x W)



Figure 5.ELI4 Phantom

2.4. Scanning Procedure

The DASY4 installation includes predefined files with recommended procedures for measurements and validation. They are read-only document files and destined as fully defined but unmeasured masks. All test positions (head or body-worn) are tested with the same configuration of test steps differing only in the grid definition for the different test positions.

- The “reference” and “drift” measurements are located at the beginning and end of the batch process. They measure the field drift at one single point in the liquid over the complete procedure. The indicated drift is mainly the variation of the DUT’s output power and should vary max. ± 5 %.
- The “surface check” measurement tests the optical surface detection system of the DASY4 system by repeatedly detecting the surface with the optical and mechanical surface detector and comparing the results. The output gives the detecting heights of both systems, the difference between the two systems and the standard deviation of the detection repeatability. Air bubbles or refraction in the liquid due to separation of the sugar-water mixture gives poor repeatability (above ± 0.1mm). To prevent wrong results tests are only executed when the liquid is free of air bubbles. The difference between the optical surface detection and the actual surface depends on the probe and is specified with each probe. (It does not depend on the surface reflectivity or the probe angle to the surface within ± 30°.)

- Area Scan

The Area Scan is used as a fast scan in two dimensions to find the area of high field values before running a detailed measurement around the hot spot. Before starting the area scan a grid spacing of 15 mm x 15 mm is set. During the scan the distance of the probe to the phantom remains unchanged.

After finishing area scan, the field maxima within a range of 2 dB will be ascertained.

- Zoom Scan

Zoom Scans are used to estimate the peak spatial SAR values within a cubic averaging volume containing 1 g and 10 g of simulated tissue. The default Zoom Scan is done by 7x7x7 points within a cube whose base is centered around the maxima found in the preceding area scan.

- Spatial Peak Detection

The procedure for spatial peak SAR evaluation has been implemented and can determine values of masses of 1g and 10g, as well as for user-specific masses. The DASY4 system allows evaluations that combine measured data and robot positions, such as:

- maximum search
- extrapolation
- boundary correction
- peak search for averaged SAR

During a maximum search, global and local maxima searches are automatically performed in 2-D after each Area Scan measurement with at least 6 measurement points. It is based on the evaluation of the local SAR gradient calculated by the Quadratic Shepard's method. The algorithm will find the global maximum and all local maxima within -2 dB of the global maxima for all SAR distributions.

Extrapolation routines are used to obtain SAR values between the lowest measurement points and the inner phantom surface. The extrapolation distance is determined by the surface detection distance and the probe sensor offset. Several measurements at different distances are necessary for the extrapolation. Extrapolation routines require at least 10 measurement points in 3-D space. They are used in the Zoom Scan to obtain SAR values between the lowest measurement points and the inner phantom surface. The routine uses the modified Quadratic Shepard's method for extrapolation. For a grid using 7x7x7 measurement points with 5mm resolution amounting to 343 measurement points, the uncertainty of the extrapolation routines is less than 1% for 1g and 10g cubes.

- A Z-axis scan measures the total SAR value at the x-and y-position of the maximum SAR value found during the cube 7x7x7 scan. The probe is moved away in z-direction from the bottom of the SAM phantom in 5mm steps.

2.5. Data Storage and Evaluation

2.5.1. Data Storage

The DASY4 software stores the acquired data from the data acquisition electronics as raw data (in microvolt readings from the probe sensors), together with all necessary software parameters for the data evaluation (probe calibration data, liquid parameters and device frequency and modulation data) in measurement files with the extension “.DA4”. The software evaluates the desired unit and format for output each time the data is visualized or exported. This allows verification of the complete software setup even after the measurement and allows correction of incorrect parameter settings. For example, if a measurement has been performed with a wrong crest factor parameter in the device setup, the parameter can be corrected afterwards and the data can be re-evaluated.

The measured data can be visualized or exported in different units or formats, depending on the selected probe type ([V/m], [A/m], [°C], [mW/g], [mW/cm²], [dBrel], etc.). Some of these units are not available in certain situations or show meaningless results, e.g., a SAR output in a lossless media will always be zero. Raw data can also be exported to perform the evaluation with other software packages.

2.5.2. Data Evaluation by SEMCAD

The SEMCAD software automatically executes the following procedures to calculate the field units from the microvolt readings at the probe connector. The parameters used in the evaluation are stored in the configuration modules of the software:

Probe parameters:	- Sensitivity	Normi, a _{i0} , a _{i1} , a _{i2}
	- Conversion factor	ConvF _i
	- Diode compression point	Dcp _i
Device parameters:	- Frequency	f
	- Crest factor	cf
Media parameters:	- Conductivity	σ
	- Density	ρ

These parameters must be set correctly in the software. They can be found in the component documents or they can be imported into the software from the configuration files issued for the DASY4 components. In the direct measuring mode of the multimeter option, the parameters of the actual system setup are used. In the scan visualization and export modes, the parameters stored in the corresponding document files are used.

The first step of the evaluation is a linearization of the filtered input signal to account for the compression characteristics of the detector diode. The compensation depends on the input signal, the diode type and the DC-transmission factor from the diode to the evaluation electronics.

TA Technology (Shanghai) Co., Ltd.
Test Report

Report No. RZA1203-0315SAR

Page 16 of 100

If the exciting field is pulsed, the crest factor of the signal must be known to correctly compensate for peak power. The formula for each channel can be given as:

$$V_i = U_i + U_i^2 \cdot c f / d c p_i$$

With V_i = compensated signal of channel i (i = x, y, z)

U_i = input signal of channel i (i = x, y, z)

cf = crest factor of exciting field (DASY parameter)

dcp_i = diode compression point (DASY parameter)

From the compensated input signals the primary field data for each channel can be evaluated:

E-field probes: $E_i = (V_i / Norm_i \cdot ConvF)^{1/2}$

H-field probes: $H_i = (V_i)^{1/2} \cdot (a_{i0} + a_{i1} f + a_{i2} f^2) / f$

With V_i = compensated signal of channel i (i = x, y, z)

$Norm_i$ = sensor sensitivity of channel i (i = x, y, z)
[mV/(V/m)²] for E-field Probes

$ConvF$ = sensitivity enhancement in solution

a_{ij} = sensor sensitivity factors for H-field probes

f = carrier frequency [GHz]

E_i = electric field strength of channel i in V/m

H_i = magnetic field strength of channel i in A/m

The RSS value of the field components gives the total field strength (Hermitian magnitude):

$$E_{tot} = (E_x^2 + E_y^2 + E_z^2)^{1/2}$$

The primary field data are used to calculate the derived field units.

$$SAR = (E_{tot}^2 \cdot \sigma) / (\rho \cdot 1000)$$

with **SAR** = local specific absorption rate in mW/g

E_{tot} = total field strength in V/m

σ = conductivity in [mho/m] or [Siemens/m]

ρ = equivalent tissue density in g/cm³

Note that the density is normally set to 1 (or 1.06), to account for actual brain density rather than the density of the simulation liquid. The power flow density is calculated assuming the excitation field to be a free space field.

$$P_{pwe} = E_{tot}^2 / 3770 \quad \text{or} \quad P_{pwe} = H_{tot}^2 \cdot 37.7$$

with **P_{pwe}** = equivalent power density of a plane wave in mW/cm²

E_{tot} = total electric field strength in V/m

H_{tot} = total magnetic field strength in A/m

3. Laboratory Environment

Table 1: The Requirements of the Ambient Conditions

Temperature	Min. = 20°C, Max. = 25 °C
Relative humidity	Min. = 30%, Max. = 70%
Ground system resistance	< 0.5 Ω
Ambient noise is checked and found very low and in compliance with requirement of standards.	
Reflection of surrounding objects is minimized and in compliance with requirement of standards.	

4. Tissue-equivalent Liquid

4.1. Tissue-equivalent Liquid Ingredients

The liquid is consisted of water, sugar, salt, Preventol and Cellulose. The liquid has previously been proven to be suited for worst-case. The Table 2 and Table 3 show the detail solution. It's satisfying the latest tissue dielectric parameters requirements proposed by the OET 65.

Table 2: Composition of the Head Tissue Equivalent Matter

MIXTURE%	FREQUENCY(Brain) 450MHz
Water	38.56
Sugar	56.32
Salt	3.95
Preventol	0.10
Cellulose	1.07
Dielectric Parameters Target Value	f=450MHz $\epsilon=43.5$ $\sigma=0.87$

Table 3: Composition of the Body Tissue Equivalent Matter

MIXTURE%	FREQUENCY(Body) 450MHz
Water	51.16
Sugar	46.78
Salt	1.49
Preventol	0.10
Cellulose	0.47
Dielectric Parameters Target Value	f=450MHz $\epsilon=56.7$ $\sigma=0.94$

TA Technology (Shanghai) Co., Ltd.
Test Report

4.2. Tissue-equivalent Liquid Properties

Table 4: Dielectric Performance of Head Tissue Simulating Liquid

Frequency	Description	Dielectric Parameters		Temp °C
		ϵ_r	σ (s/m)	
450MHz (head)	Target value ±5% window	43.50 41.33 — 45.68	0.87 0.83 — 0.91	22.0
	Measurement value 2012-3-23	44.11	0.88	21.6

Table 5: Dielectric Performance of Body Tissue Simulating Liquid

Frequency	Description	Dielectric Parameters		Temp °C
		ϵ_r	σ (s/m)	
450MHz (body)	Target value ±5% window	56.70 53.87 — 59.54	0.94 0.89 — 0.99	22.0
	Measurement value 2012-3-23	55.02	0.92	21.5

5. System Check

5.1. Description of System Check

The manufacturer calibrates the probes annually. Dielectric parameters of the tissue simulants were measured every day using the dielectric probe kit and the network analyser. A system check measurement was made following the determination of the dielectric parameters of the simulant, using the dipole validation kit. A power level of 398 mW was supplied to the dipole antenna, which was placed under the flat section of the twin SAM phantom. The system check results (dielectric parameters and SAR values) are given in the table 6 and table 7.

System check results have to be equal or near the values determined during dipole calibration with the relevant liquids and test system ($\pm 10\%$).

System check is performed regularly on all frequency bands where tests are performed with the DASY4 system.

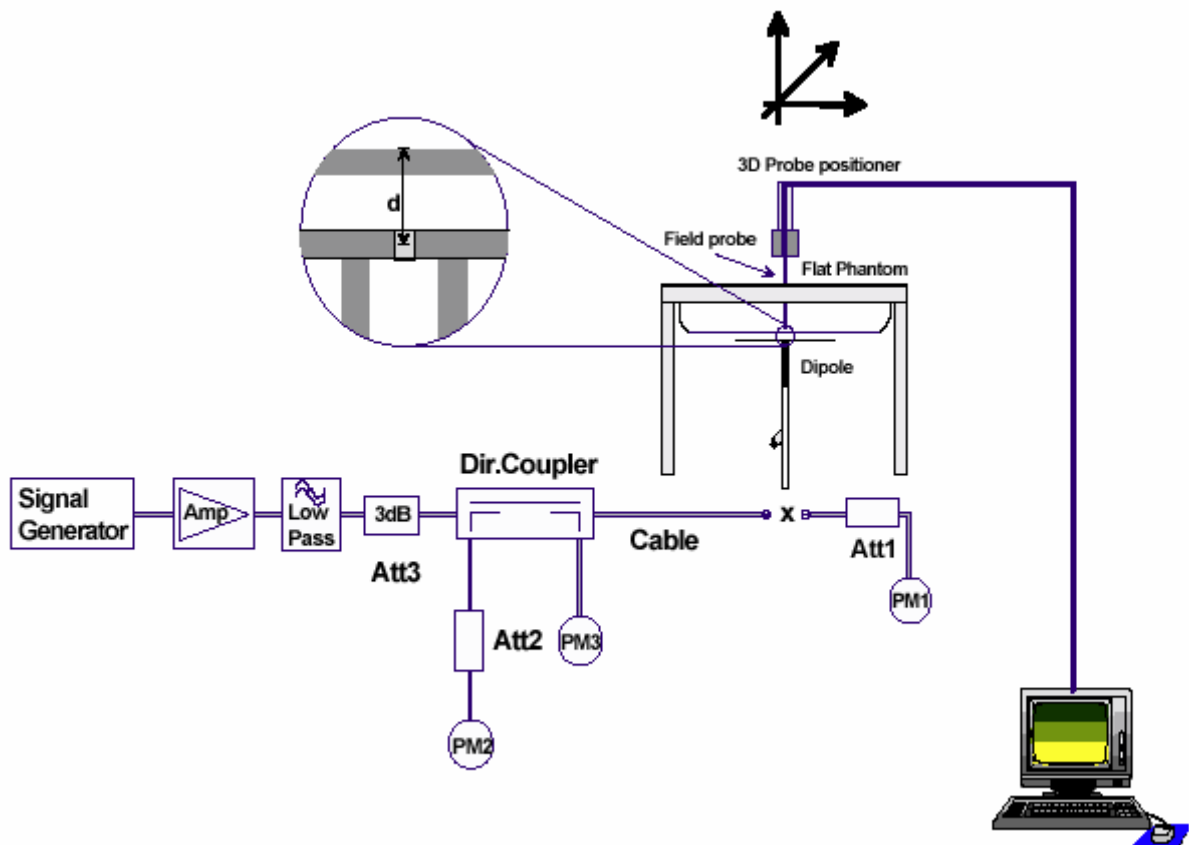

Figure 6. System Check Set-up

TA Technology (Shanghai) Co., Ltd.
Test Report

Report No. RZA1203-0315SAR

Page 21 of 100

Justification for Extended SAR Dipole Calibrations

Usage of SAR dipoles calibrated less than 2 years ago but more than 1 year ago were confirmed in maintaining return loss (< - 20 dB, within 20% of prior calibration) and impedance (within 5 ohm from prior calibration) requirements per extended calibrations in KDB Publication 450824:

Dipole D450V3 SN: 1065				
Head Liquid				
Date of Measurement	Return Loss(dB)	Δ %	Impedance (Ω)	$\Delta\Omega$
11/09/2010	-20.5	3.4%	59.2	1.4 Ω
11/08/2011	-21.2		60.6	
Body Liquid				
Date of Measurement	Return Loss(dB)	Δ %	Impedance (Ω)	$\Delta\Omega$
11/09/2010	-20.4	2.9%	56.5	1.6 Ω
11/08/2011	-19.8		58.1	

TA Technology (Shanghai) Co., Ltd.
Test Report

5.2. System Check Results

Table 6: System Check for Head Tissue Simulating Liquid

Frequency	Test Date	Dielectric Parameters		Temp	398mW Measured SAR _{1g}	1W Normalized SAR _{1g}	1W Target SAR _{1g} (±10% Deviation)
		ϵ_r	σ (s/m)	(°C)	(W/kg)		
450MHz	2012-3-23	44.11	0.88	21.6	2.00	5.03	4.76 (4.28 ~ 5.24)

Note: 1. The graph results see ANNEX B.
2. Target Value used derive from the calibration certificate

Table 7: System Check for Body Tissue Simulating Liquid

Frequency	Test Date	Dielectric Parameters		Temp	398mW Measured SAR _{1g}	1W Normalized SAR _{1g}	1W Target SAR _{1g} (±10% Deviation)
		ϵ_r	σ (s/m)	(°C)	(W/kg)		
450MHz	2012-3-23	55.02	0.92	21.5	1.78	4.47	4.51 (4.06 ~ 4.96)

Note: 1. The graph results see ANNEX B.
2. Target Value used derive from the calibration certificate

6. Operational Conditions during Test

6.1. General Description of Test Procedures

The spatial peak SAR values were assessed for UHF (400.5 MHz, 418 MHz, 435.5MHz, 452.5MHz and 469.5MHz) systems. Battery and accessories shall be specified by the manufacturer. The EUT battery must be fully charged and checked periodically during the test to ascertain uniform power output.

6.2. Test Configuration

6.2.1. Face-Held Configuration

Face-held Configuration - Default Battery Selection - per FCC KDB 643646, Page 2, Section 1) A):
“When multiple standard batteries are supplied with a radio, the battery with the highest capacity is considered the default battery for making head SAR measurements.”

6.2.2. Body-Worn Configuration

a. Body-worn Configuration - Default Battery Selection - per FCC KDB 643646, Page 5, Section 1) A):
Start by testing a PTT radio with the thinnest battery and a standard (default) Body-worn accessory.

b. Body-worn Configuration - Default Body-worn Accessory Selection - the belt-clip was selected as the default Body-worn accessory based on the smaller separation distance it provides between the radio and the user in comparison to the remaining accessories. Per FCC KDB 643646, Page 5, Section 1) A): “When multiple default Body-worn accessories are supplied with a radio, the standard Body-worn accessory expected to result in the highest SAR based on its construction and exposure conditions is considered the default Body-worn accessory for making Body-worn measurements.”

c. Body-worn Configuration - Additional Body-worn Accessories - the remaining Body-worn accessories were evaluated based on the “additional Body-worn accessory” guidance provided in FCC KDB 643646, Page 7, Section 4). The remaining Body-worn accessories can be utilized with all the audio accessory options.

d. Body-worn Configuration - Selection of Default Audio Accessories by Category - the Default Audio Accessories by Category were selected based on the guidance provided in FCC KDB 643646, Section “Body SAR Test Considerations for Audio Accessories without Built-in Antenna”, Page 10: “For audio accessories with similar construction and operating requirements, test only the audio accessory within the group that is expected to result in the highest SAR, with respect to changes in RF characteristics and exposure conditions for the combination. If it is unclear which audio accessory within a group of similar accessories is expected to result in the highest SAR, good engineering judgment and preliminary testing should be applied to select the accessory that is expected to result in the highest SAR.” The Remaining Audio Accessories by Category were evaluated on the highest SAR channel from the Default Audio Accessory evaluations.

7. Test Results

7.1. Conducted Power Results

Table 8: Conducted Power Measurement Results

Analog UHF (12.5KHz)	Conducted Power				
	400.5 MHz	418MHz	435.5MHz	452.5MHz	469.5MHz
Test Result (dBm)	36.79	36.79	36.69	36.74	36.81
Digital UHF	Conducted Power				
	400.5 MHz	418MHz	435.5MHz	452.5MHz	469.5MHz
Test Result (dBm)	36.69	36.76	36.73	36.80	36.79

TA Technology (Shanghai) Co., Ltd.

Test Report

7.2. SAR Test Results

7.2.1. UHF

Table 9: SAR Values (UHF)

Limits	1 g Average (W/kg)		Power Drift (dB)	Graph Results
	8.0		± 0.21	
Frequency	Duty Cycle		Power Drift (dB)	
	100%	50%		
The EUT display towards phantom for 12.5 KHz with Thicker Battery (Analog, Face Held)				
418MHz	5.110	2.555	-0.167	Figure 9
Worst case position with Thinner Battery (Analog, Face Held)				
418MHz	4.580	2.290	-0.077	Figure 10
The EUT display towards ground for 12.5 KHz with Thinner Battery, Belt and Accessory 1 (Analog, Body-Worn)				
400.5MHz	8.550	4.275	-0.033	Figure 11
418MHz	7.500	3.750	-0.156	Figure 12
435.5MHz	7.740	3.870	-0.021	Figure 13
452.5MHz	5.860	2.930	-0.090	Figure 14
469.5MHz	6.010	3.005	-0.061	Figure 15
The EUT display towards ground for 12.5 KHz with Thinner Battery, Belt, Accessory 1 and Earphone 1 (Analog, Body-Worn)				
400.5MHz	8.560	4.280	-0.127	Figure 16
The EUT display towards ground for 12.5 KHz with Thinner Battery, Belt, Accessory 1 and Earphone 2 (Analog, Body-Worn)				
400.5MHz	8.370	4.185	-0.024	Figure 17
The EUT display towards ground for 12.5 KHz with Thinner Battery, Belt and Audio Accessory 2 (Analog, Body-Worn)				
400.5MHz	8.590	4.295	-0.069	Figure 18
The EUT display towards ground for 12.5 KHz with Thinner Battery, Belt and Audio Accessory 3 (Analog, Body-Worn)				
400.5MHz	7.920	3.960	-0.040	Figure 19
The EUT display towards ground for 12.5 KHz with Thinner Battery, Belt and Audio Accessory 4 (Body-Worn)				
400.5MHz	7.990	3.995	-0.035	Figure 20

TA Technology (Shanghai) Co., Ltd.
Test Report

The EUT display towards ground for 12.5 KHz with Thinner Battery, Belt and Audio Accessory 5 (Analog, Body-Worn)				
400.5MHz	8.200	4.100	-0.016	Figure 21
The EUT display towards ground for 12.5 KHz with Thinner Battery, Pocket and Accessory 1 (Analog, Body-Worn)				
400.5MHz	8.040	4.020	-0.072	Figure 22
The EUT display towards ground for 12.5 KHz with Thinner Battery, Pocket, Leather and Accessory 1 (Analog, Body-Worn)				
400.5MHz	5.100	2.550	0.042	Figure 23
Worst case position of Analog for Digital with Thinner Battery, Belt and Audio Accessory 2 (Body-Worn)				
400.5 MHz	3.680	1.840	-0.171	Figure 24
Worst case position with Thicker Battery, Belt and Audio Accessory 2 (Analog, Body-Worn)				
400.5 MHz	8.360	4.180	-0.058	Figure 25
<p>Note: 1. For face-held configuration, battery “Thicker” was selected as the default battery (highest mAh).</p> <p>2. When the head SAR of an antenna tested on the highest output power channel with the default battery is < 3.5 W/kg, testing of all other required channels is not necessary.</p> <p>3. When the SAR for all antennas tested using the default battery is ≤ 4.0 W/kg, test additional batteries using the antenna and channel configuration that resulted in the highest SAR among all antennas.</p> <p>4. For body-worn configuration, battery “Thinner” was selected as the default battery.</p> <p>5. When the body SAR of an antenna is > 4 W/kg and ≤ 6.0 W/kg, testing of all other required channels is required for that antenna.</p> <p>6. When the highest SAR of an antenna tested with the default battery using the default body-worn and audio accessory is > 4 W/kg and ≤ 6.0 W/kg, test additional batteries with the default body-worn and audio accessory on the channel that resulted in the highest SAR for that antenna.</p> <p>7. The audio accessory Speaker Mic was selected as the default audio accessory based on preliminary evaluations resulting in the most conservative SAR of all the disclosed audio accessory options.</p>				

TA Technology (Shanghai) Co., Ltd.
Test Report

Table 10: SAR Values are scaled for the power drift

Limits	1 g Average (W/kg)		Power Drift (dB)	+ Power Drift 10^(dB/10)	SAR 1g (W/kg) (include + power drift)	
	8.0		± 0.21		Duty Cycle	
Frequency	Duty Cycle		Power Drift(dB)		Duty Cycle	
	100%	50%			100%	50%
The EUT display towards phantom for 12.5 KHz with Thicker Battery (Analog, Face Held)						
418MHz	5.110	2.555	0.167	1.039	5.310	2.655
Worst case position with Thinner Battery (Analog, Face Held)						
418MHz	4.580	2.290	0.077	1.018	4.662	2.331
The EUT display towards ground for 12.5 KHz with Thinner Battery, Belt and Accessory 1 (Analog, Body-Worn)						
400.5MHz	8.550	4.275	0.033	1.008	8.615	4.308
418MHz	7.500	3.750	0.156	1.037	7.774	3.887
435.5MHz	7.740	3.870	0.021	1.005	7.778	3.889
452.5MHz	5.860	2.930	0.090	1.021	5.983	2.991
469.5MHz	6.010	3.005	0.061	1.014	6.095	3.048
The EUT display towards ground for 12.5 KHz with Thinner Battery, Belt, Accessory 1 and Earphone 1 (Analog, Body-Worn)						
400.5MHz	8.560	4.280	0.127	1.030	8.814	4.407
The EUT display towards ground for 12.5 KHz with Thinner Battery, Belt, Accessory 1 and Earphone 2 (Analog, Body-Worn)						
400.5MHz	8.370	4.185	0.024	1.006	8.416	4.208
The EUT display towards ground for 12.5 KHz with Thinner Battery, Belt and Audio Accessory 2 (Analog, Body-Worn)						
400.5MHz	8.590	4.295	0.069	1.016	8.728	4.364
The EUT display towards ground for 12.5 KHz with Thinner Battery, Belt and Audio Accessory 3 (Analog, Body-Worn)						
400.5MHz	7.920	3.960	0.040	1.009	7.993	3.997
The EUT display towards ground for 12.5 KHz with Thinner Battery, Belt and Audio Accessory 4 (Analog, Body-Worn)						
400.5MHz	7.990	3.995	0.035	1.008	8.055	4.027

TA Technology (Shanghai) Co., Ltd.
Test Report

Report No. RZA1203-0315SAR

Page 28 of 100

The EUT display towards ground for 12.5 KHz with Thinner Battery, Belt and Audio Accessory 5 (Analog, Body-Worn)						
400.5MHz	8.200	4.100	0.016	1.004	8.230	4.115
The EUT display towards ground for 12.5 KHz with Thinner Battery, Pocket and Accessory 1 (Analog, Body-Worn)						
400.5MHz	8.040	4.020	0.072	1.017	8.174	4.087
The EUT display towards ground for 12.5 KHz with Thinner Battery, Pocket, Leather and Accessory 1 (Analog, Body-Worn)						
400.5MHz	5.100	2.550	0.042	1.010	5.150	2.575
Worst case position of Analog for Digital with Thinner Battery, Belt and Audio Accessory 2 (Body-Worn)						
400.5MHz	3.680	1.840	0.171	1.040	3.828	1.914
Worst case position with Thicker Battery, Belt and Audio Accessory 2 (Analog, Body-Worn)						
400.5 MHz	8.360	4.180	0.058	1.013	8.472	4.236
<p>Note: 1. The value with blue color is the maximum SAR Value of each test band.</p> <p>2. The Exposure category about EUT: controlled environment / Occupational, so the SAR limit is 8.0 W/kg averaged over any 1 gram of tissue.</p> <p>3. The SAR levels reported are based on 50% PTT duty factor including SAR droop.</p>						

TA Technology (Shanghai) Co., Ltd.
Test Report

Report No. RZA1203-0315SAR

Page 29 of 100

6. Measurement Uncertainty

No.	source	Type	Uncertainty Value (%)	Probability Distribution	k	c _i	Standard uncertainty u _i (%)	Degree of freedom V _{eff} or V _i
1	System repetivity	A	0.5	N	1	1	0.5	9
Measurement system								
2	-probe calibration	B	6.7	N	1	1	6.7	∞
3	-axial isotropy of the probe	B	4.7	R	$\sqrt{3}$	$\sqrt{0.5}$	1.9	∞
4	- Hemispherical isotropy of the probe	B	9.4	R	$\sqrt{3}$	$\sqrt{0.5}$	3.9	∞
6	-boundary effect	B	1.9	R	$\sqrt{3}$	1	1.1	∞
7	-probe linearity	B	4.7	R	$\sqrt{3}$	1	2.7	∞
8	- System detection limits	B	1.0	R	$\sqrt{3}$	1	0.6	∞
9	-readout Electronics	B	1.0	N	1	1	1.0	∞
10	-response time	B	0	R	$\sqrt{3}$	1	0	∞
11	-integration time	B	4.32	R	$\sqrt{3}$	1	2.5	∞
12	-noise	B	0	R	$\sqrt{3}$	1	0	∞
13	-RF Ambient Conditions	B	3	R	$\sqrt{3}$	1	1.73	∞
14	-Probe Positioner Mechanical Tolerance	B	0.4	R	$\sqrt{3}$	1	0.2	∞
15	-Probe Positioning with respect to Phantom Shell	B	2.9	R	$\sqrt{3}$	1	1.7	∞
16	-Extrapolation, interpolation and Integration Algorithms for Max. SAR Evaluation	B	3.9	R	$\sqrt{3}$	1	2.3	∞
Test sample Related								
17	-Test Sample Positioning	A	2.9	N	1	1	2.9	71
18	-Device Holder Uncertainty	A	4.1	N	1	1	4.1	5
19	-Output Power Variation - SAR drift measurement	B	5.0	R	$\sqrt{3}$	1	2.9	∞
Physical parameter								
20	-phantom	B	4.0	R	$\sqrt{3}$	1	2.3	∞

TA Technology (Shanghai) Co., Ltd.
Test Report

Report No. RZA1203-0315SAR

Page 30 of 100

21	-liquid conductivity (deviation from target)	B	5.0	R	$\sqrt{3}$	0.64	1.8	∞
22	-liquid conductivity (measurement uncertainty)	B	2.5	N	1	0.64	1.6	9
23	-liquid permittivity (deviation from target)	B	5.0	R	$\sqrt{3}$	0.6	1.7	∞
24	-liquid permittivity (measurement uncertainty)	B	2.5	N	1	0.6	1.5	9
Combined standard uncertainty		$u_c = \sqrt{\sum_{i=1}^{21} c_i^2 u_i^2}$					12.53	
Expanded uncertainty (confidence interval of 95 %)		$u_e = 2u_c$		N	k=2	23.76		

TA Technology (Shanghai) Co., Ltd.
Test Report

Report No. RZA1203-0315SAR

Page 31 of 100

7. Main Test Instruments

Table 11: List of Main Instruments

No.	Name	Type	Serial Number	Calibration Date	Valid Period
01	Network analyzer	Agilent 8753E	US37390326	September 12, 2011	One year
02	Dielectric Probe Kit	Agilent 85070E	US44020115	No Calibration Requested	
03	Power meter	Agilent E4417A	GB41291714	March 11, 2012	One year
04	Power sensor	Agilent N8481H	MY50350004	September 25, 2011	One year
05	Power sensor	E9327A	US40441622	September 24, 2011	One year
06	Signal Generator	HP 8341B	2730A00804	September 12, 2011	One year
07	Amplifier	IXA-020	0401	No Calibration Requested	
08	E-field Probe	EX3DV4	3816	October 3, 2011	One year
09	DAE	DAE4	871	November 22, 2011	One year
10	Validation Kit 450MHz	D450V3	1065	November 9, 2010	Two years
11	Dual directional coupler	778D-012	5051P	August 21, 2011	One year
12	Temperature Probe	JM222	AA1009129	March 15, 2012	One year
13	Hygrothermograph	HTC-1	TASH121602	June 21, 2011	One year

*****END OF REPORT *****

ANNEX A: Test Layout

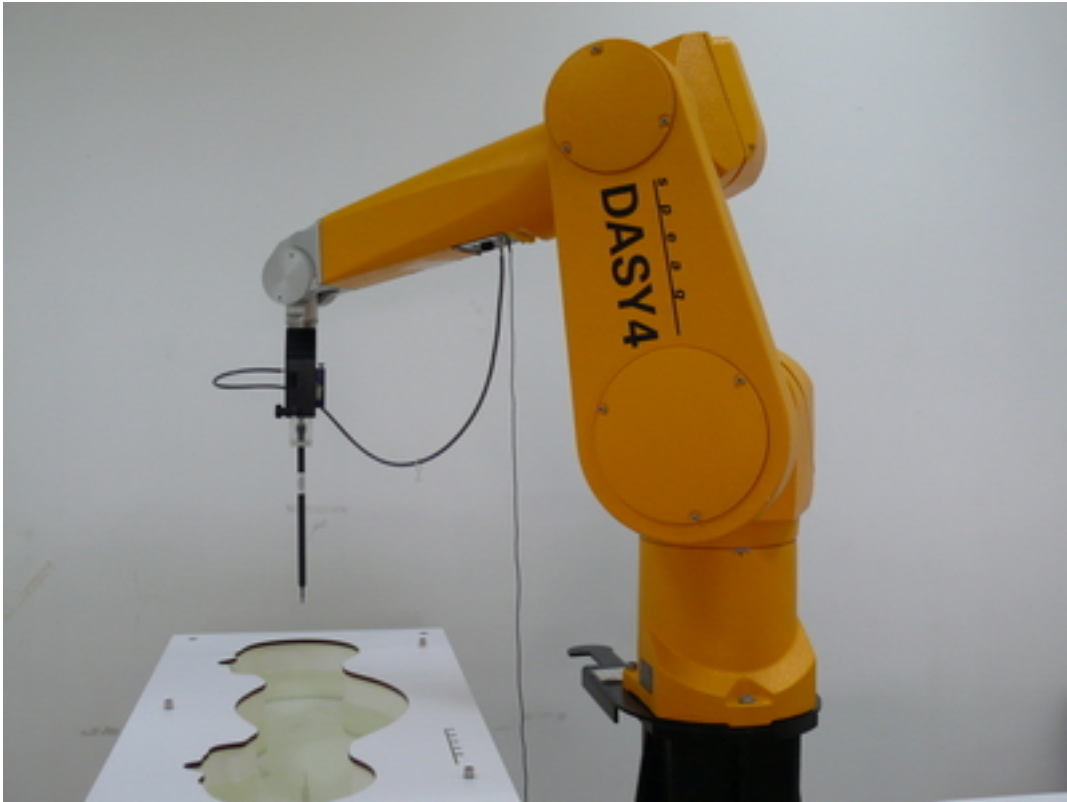

Picture 1: Specific Absorption Rate Test Layout



Picture 2: Liquid depth in the Flat Phantom (450 MHz, 15.4cm depth)

ANNEX B: System Check Results

System Performance Check at 450 MHz Head TSL

DUT: Dipole450 MHz; Type: D450V3; Serial: 1065

Date/Time: 3/23/2012 7:21:21 AM

Communication System: CW; Frequency: 450 MHz; Duty Cycle: 1:1

Medium parameters used: $f = 450$ MHz; $\sigma = 0.88$ mho/m; $\epsilon_r = 44.11$; $\rho = 1000$ kg/m³

Ambient Temperature: 22.3 °C Liquid Temperature: 21.6 °C

DASY4 Configuration:

Probe: EX3DV4 - SN3816; ConvF(9.97, 9.97, 9.97) Calibrated: 10/3/2011;

Electronics: DAE4 Sn871; Calibrated: 11/22/2011

Phantom: SAM 12; Type: SAM V4.0; Serial: TP-1246

Measurement SW: DASY4, V4.7 Build 80; Postprocessing SW: SEMCAD, V1.8 Build 186

d=15mm, Pin=398mW/Area Scan (41x131x1): Measurement grid: dx=15mm, dy=15mm
Maximum value of SAR (interpolated) = 2.15 mW/g

d=15mm, Pin=398mW/Zoom Scan (7x7x7)/Cube 0: Measurement grid: dx=5mm, dy=5mm, dz=5mm

Reference Value = 52.2 V/m; Power Drift = -0.033 dB

Peak SAR (extrapolated) = 3.29 W/kg

SAR(1 g) = 2.00 mW/g; SAR(10 g) = 1.31 mW/g

Maximum value of SAR (measured) = 2.15 mW/g

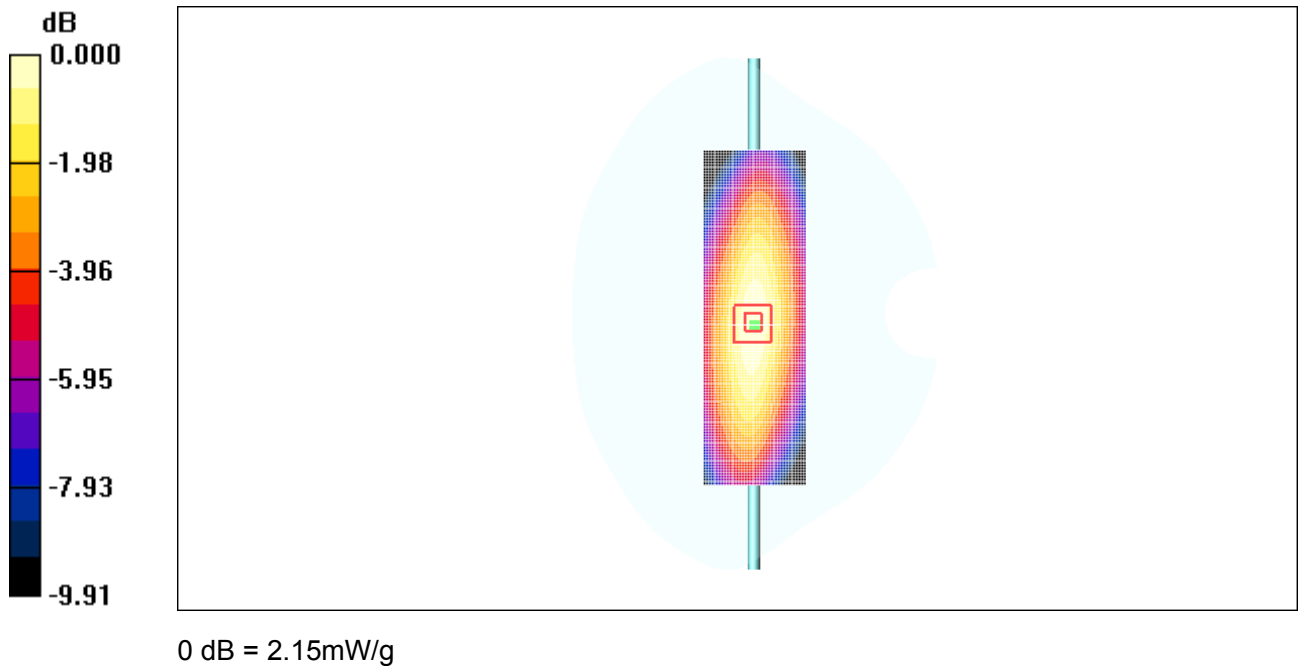

Figure 7 System Performance Check 450MHz 398mW

System Performance Check at 450 MHz Body TSL

DUT: Dipole450 MHz; Type: D450V3; Serial: 1065

Date/Time: 3/23/2012 9:00:21 AM

Communication System: CW; Frequency: 450 MHz; Duty Cycle: 1:1

Medium parameters used: $f = 450 \text{ MHz}$; $\sigma = 0.92 \text{ mho/m}$; $\epsilon_r = 55.02$; $\rho = 1000 \text{ kg/m}^3$

Ambient Temperature: $22.3 \text{ }^\circ\text{C}$ Liquid Temperature: $21.5 \text{ }^\circ\text{C}$

DASY4 Configuration:

Probe: EX3DV4 - SN3816; ConvF(10.83, 10.83, 10.83) Calibrated: 10/3/2011;

Electronics: DAE4 Sn871; Calibrated: 11/22/2011

Phantom: SAM 12; Type: SAM V4.0; Serial: TP-1246

Measurement SW: DASY4, V4.7 Build 80; Postprocessing SW: SEMCAD, V1.8 Build 186

d=15mm, Pin=398mW/Area Scan (61x221x1): Measurement grid: dx=15mm, dy=15mm
Maximum value of SAR (interpolated) = 1.9 mW/g

d=15mm, Pin=398mW/Zoom Scan (7x7x7)/Cube 0: Measurement grid: dx=5mm, dy=5mm, dz=5mm

Reference Value = 44.7 V/m; Power Drift = -0.014 dB

Peak SAR (extrapolated) = 2.64 W/kg

SAR(1 g) = 1.78 mW/g; SAR(10 g) = 1.17 mW/g

Maximum value of SAR (measured) = 1.89 mW/g

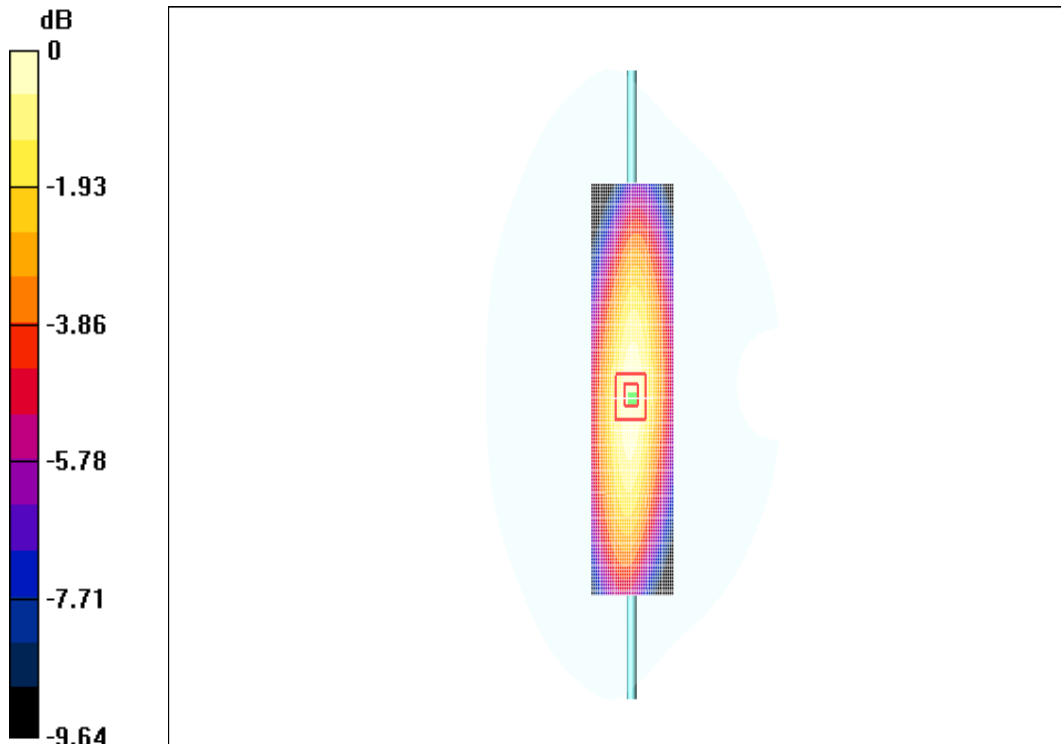

0 dB = 1.89mW/g

Figure 8 System Performance Check 450MHz 398mW

ANNEX C: Graph Results

Face Held with Thicker Battery, Front towards Phantom 418MHz (12.5 KHz Channel Spacing)

Date/Time: 3/23/2012 3:48:58 PM

Communication System: PTT 400-470; Frequency: 418 MHz; Duty Cycle: 1:1

Medium parameters used: $f = 418$ MHz; $\sigma = 0.856$ mho/m; $\epsilon_r = 44.8$; $\rho = 1000$ kg/m³

Ambient Temperature: 22.3 °C Liquid Temperature: 21.5°C

Phantom section: Flat Section

DASY4 Configuration:

Probe: EX3DV4 - SN3816; ConvF(9.97, 9.97, 9.97) Calibrated: 10/3/2011;

Electronics: DAE4 Sn871; Calibrated: 11/22/2011

Phantom: SAM 12; Type: SAM V4.0; Serial: TP-1246

Measurement SW: DASY4, V4.7 Build 80; Postprocessing SW: SEMCAD, V1.8 Build 186

Towards Phantom 418MHz/Area Scan (51x121x1): Measurement grid: dx=15mm, dy=15mm

Maximum value of SAR (interpolated) = 5.44 mW/g

Towards Phantom 418MHz/Zoom Scan (7x7x7)/Cube 0: Measurement grid: dx=5mm, dy=5mm, dz=5mm

Reference Value = 81.7 V/m; Power Drift = -0.167 dB

Peak SAR (extrapolated) = 6.70 W/kg

SAR(1 g) = 5.11 mW/g; SAR(10 g) = 3.93 mW/g

Maximum value of SAR (measured) = 5.33 mW/g

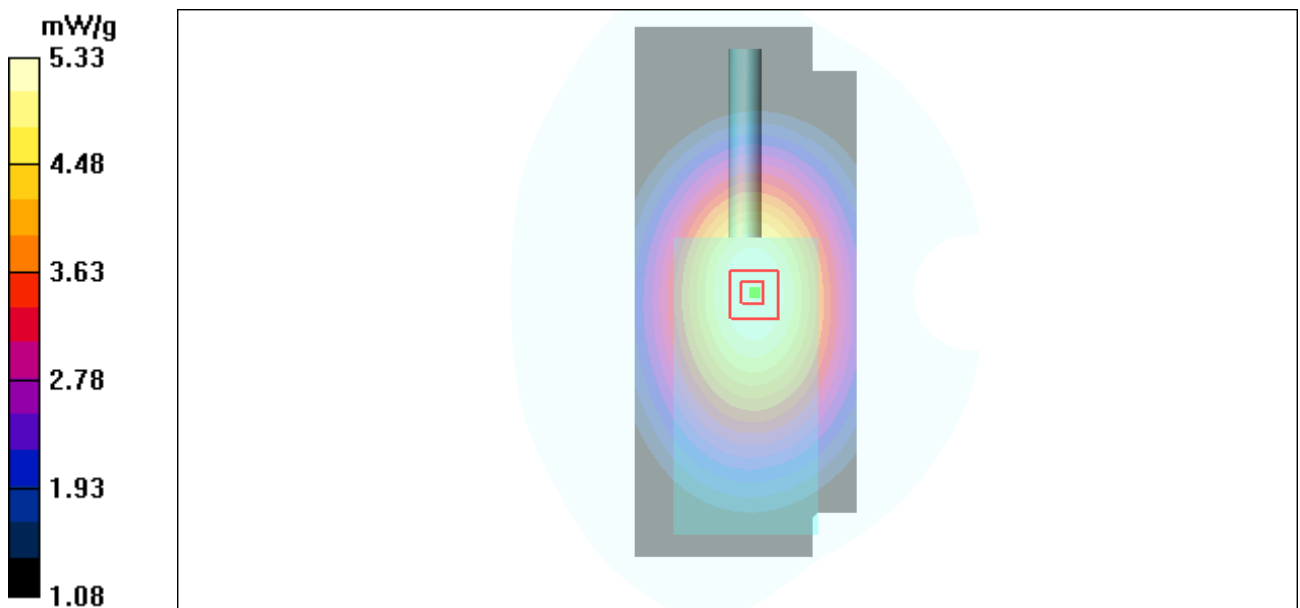

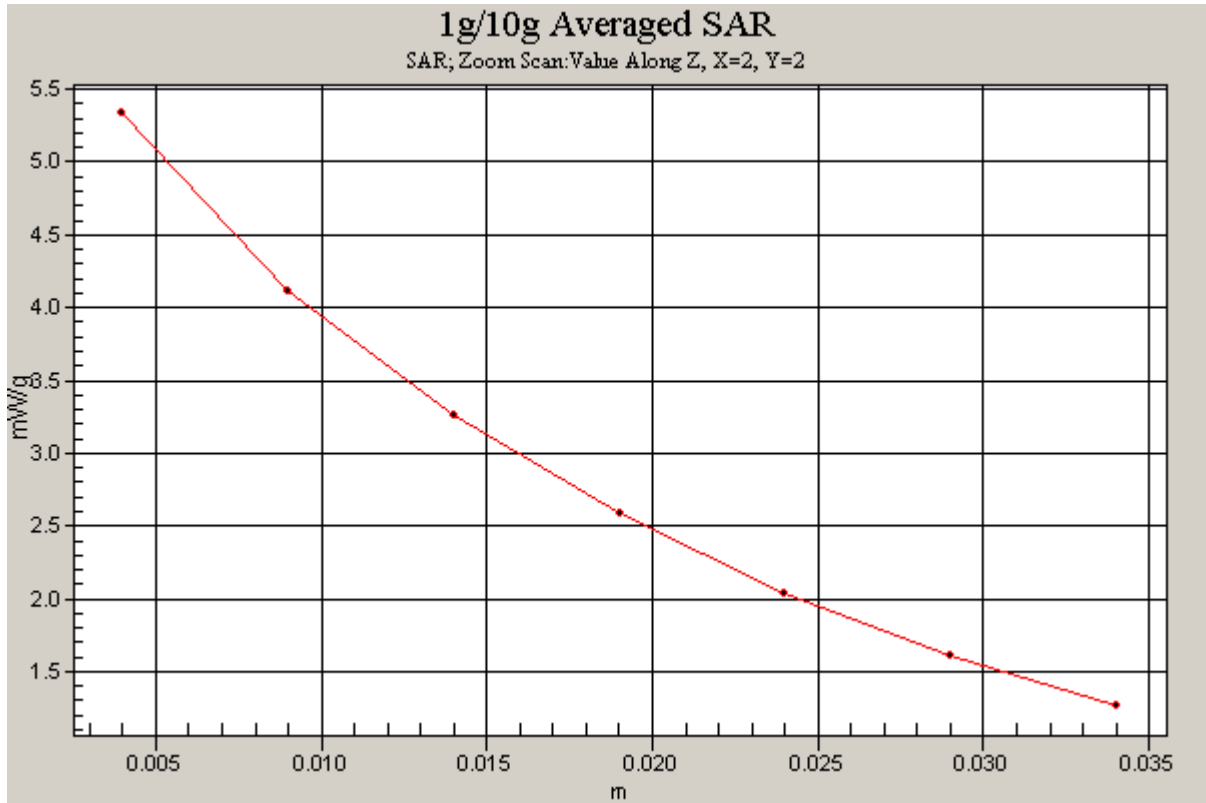

Figure 9 Face Held for 12.5 KHz with Thicker Battery, Front towards Phantom 418MHz (12.5 KHz Channel Spacing)

TA Technology (Shanghai) Co., Ltd.
Test Report

Face Held with Thinner Battery, Front towards Phantom 418MHz (12.5 KHz Channel Spacing)

Date/Time: 3/23/2012 4:46:51 PM

Communication System: PTT 400-470; Frequency: 418 MHz; Duty Cycle: 1:1

Medium parameters used: $f = 418 \text{ MHz}$; $\sigma = 0.856 \text{ mho/m}$; $\epsilon_r = 44.8$; $\rho = 1000 \text{ kg/m}^3$

Ambient Temperature: $22.3 \text{ }^\circ\text{C}$ Liquid Temperature: $21.5 \text{ }^\circ\text{C}$

Phantom section: Flat Section

DASY4 Configuration:

Probe: EX3DV4 - SN3816; ConvF(9.97, 9.97, 9.97) Calibrated: 10/3/2011;

Electronics: DAE4 Sn871; Calibrated: 11/22/2011

Phantom: SAM 12; Type: SAM V4.0; Serial: TP-1246

Measurement SW: DASY4, V4.7 Build 80; Postprocessing SW: SEMCAD, V1.8 Build 186

Towards Phantom 418MHz/Area Scan (51x121x1): Measurement grid: $dx=15\text{mm}$, $dy=15\text{mm}$
Maximum value of SAR (interpolated) = 4.80 mW/g

Towards Phantom 418MHz/Zoom Scan (7x7x7)/Cube 0: Measurement grid: $dx=5\text{mm}$, $dy=5\text{mm}$,
 $dz=5\text{mm}$

Reference Value = 75.8 V/m ; Power Drift = -0.077 dB

Peak SAR (extrapolated) = 6.03 W/kg

SAR(1 g) = 4.58 mW/g ; SAR(10 g) = 3.5 mW/g

Maximum value of SAR (measured) = 4.77 mW/g

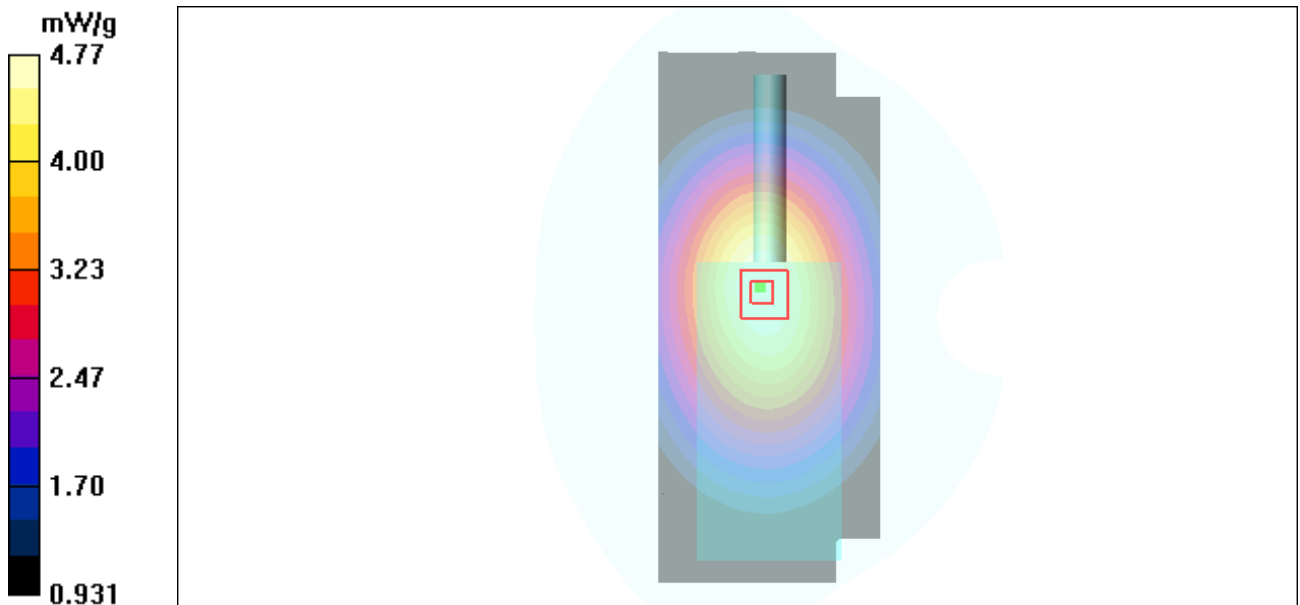

Figure 10 Face Held with Thinner Battery, Front towards Phantom 418MHz (12.5 KHz Channel Spacing)

**Body-Worn with Thinner Battery, Belt and Accessory 1, Front towards Ground
400.5MHz (12.5 KHz Channel Spacing)**

Date/Time: 3/23/2012 11:23:12 AM

Communication System: PTT 400-470; Frequency: 400.5 MHz; Duty Cycle: 1:1

Medium parameters used (interpolated): $f = 400.5$ MHz; $\sigma = 0.895$ mho/m; $\epsilon_r = 56.1$; $\rho = 1000$ kg/m³

Ambient Temperature: 22.3 °C Liquid Temperature: 21.5 °C

Phantom section: Flat Section

DASY4 Configuration:

Probe: EX3DV4 - SN3816; ConvF(10.83, 10.83, 10.83) Calibrated: 10/3/2011;

Electronics: DAE4 Sn871; Calibrated: 11/22/2011

Phantom: SAM 12; Type: SAM V4.0; Serial: TP-1246

Measurement SW: DASY4, V4.7 Build 80; Postprocessing SW: SEMCAD, V1.8 Build 186

Towards Ground 400.5MHz/Area Scan (51x121x1): Measurement grid: dx=15mm, dy=15mm
Maximum value of SAR (interpolated) = 8.89 mW/g

Towards Ground 400.5MHz/Zoom Scan (7x7x7)/Cube 0: Measurement grid: dx=5mm, dy=5mm,
dz=5mm

Reference Value = 95.1 V/m; Power Drift = -0.033 dB

Peak SAR (extrapolated) = 12.7 W/kg

SAR(1 g) = 8.55 mW/g; SAR(10 g) = 6.04 mW/g

Maximum value of SAR (measured) = 9.04 mW/g

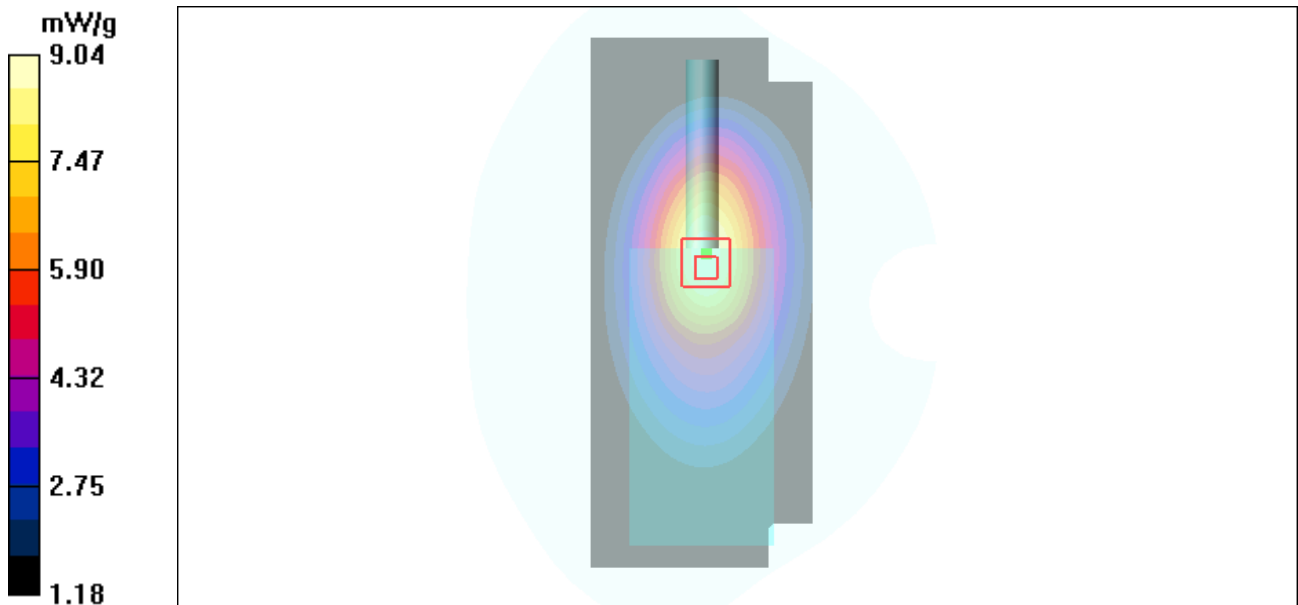

**Figure 11 Body-Worn with Thinner Battery, Belt and Accessory 1, Front towards Ground
400.5MHz (12.5 KHz Channel Spacing)**

TA Technology (Shanghai) Co., Ltd.
Test Report

**Body-Worn with Thinner Battery, Belt and Accessory 1, Front towards Ground
418MHz (12.5 KHz Channel Spacing)**

Date/Time: 3/23/2012 12:21:00 PM

Communication System: PTT 400-470; Frequency: 418 MHz; Duty Cycle: 1:1

Medium parameters used: $f = 418 \text{ MHz}$; $\sigma = 0.902 \text{ mho/m}$; $\epsilon_r = 55.6$; $\rho = 1000 \text{ kg/m}^3$

Ambient Temperature: $22.3 \text{ }^\circ\text{C}$ Liquid Temperature: $21.5 \text{ }^\circ\text{C}$

Phantom section: Flat Section

DASY4 Configuration:

Probe: EX3DV4 - SN3816; ConvF(10.83, 10.83, 10.83) Calibrated: 10/3/2011;

Electronics: DAE4 Sn871; Calibrated: 11/22/2011

Phantom: SAM 12; Type: SAM V4.0; Serial: TP-1246

Measurement SW: DASY4, V4.7 Build 80; Postprocessing SW: SEMCAD, V1.8 Build 186

Towards Ground 418MHz/Area Scan (51x121x1): Measurement grid: $dx=15\text{mm}$, $dy=15\text{mm}$
Maximum value of SAR (interpolated) = 7.86 mW/g

Towards Ground 418MHz/Zoom Scan (7x7x7)/Cube 0: Measurement grid: $dx=5\text{mm}$, $dy=5\text{mm}$,
 $dz=5\text{mm}$

Reference Value = 90.7 V/m ; Power Drift = -0.156 dB

Peak SAR (extrapolated) = 11.2 W/kg

SAR(1 g) = 7.5 mW/g ; SAR(10 g) = 5.3 mW/g

Maximum value of SAR (measured) = 7.87 mW/g

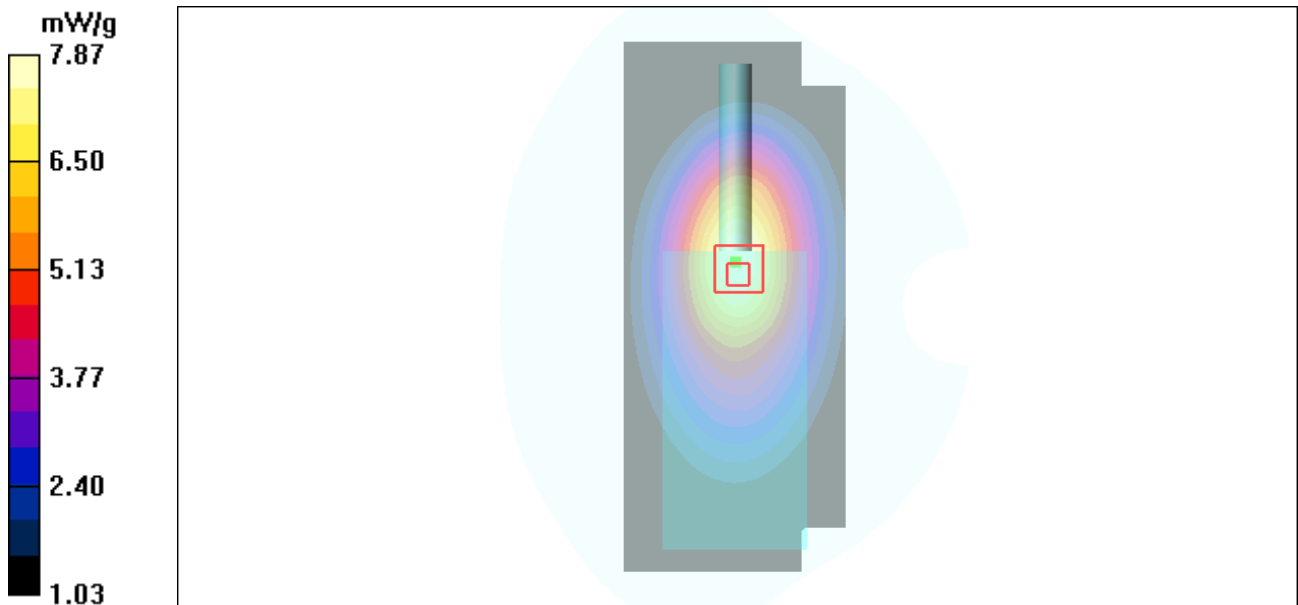

**Figure 12 Body-Worn with Thinner Battery, Belt and Accessory 1, Front towards Ground
418MHz (12.5 KHz Channel Spacing)**

**Body-Worn with Thinner Battery, Belt and Accessory 1, Front towards Ground
435.5MHz (12.5 KHz Channel Spacing)**

Date/Time: 3/23/2012 12:35:18 PM

Communication System: PTT 400-470; Frequency: 435.5 MHz; Duty Cycle: 1:1

Medium parameters used (interpolated): $f = 435.5$ MHz; $\sigma = 0.915$ mho/m; $\epsilon_r = 55.3$; $\rho = 1000$ kg/m³

Ambient Temperature: 22.3 °C Liquid Temperature: 21.5°C

Phantom section: Flat Section

DASY4 Configuration:

Probe: EX3DV4 - SN3816; ConvF(10.83, 10.83, 10.83) Calibrated: 10/3/2011;

Electronics: DAE4 Sn871; Calibrated: 11/22/2011

Phantom: SAM 12; Type: SAM V4.0; Serial: TP-1246

Measurement SW: DASY4, V4.7 Build 80; Postprocessing SW: SEMCAD, V1.8 Build 186

Towards Ground 435.5MHz/Area Scan (51x121x1): Measurement grid: dx=15mm, dy=15mm
Maximum value of SAR (interpolated) = 8.10 mW/g

Towards Ground 435.5MHz/Zoom Scan (7x7x7)/Cube 0: Measurement grid: dx=5mm, dy=5mm,
dz=5mm

Reference Value = 91.3 V/m; Power Drift = -0.021 dB

Peak SAR (extrapolated) = 11.6 W/kg

SAR(1 g) = 7.74 mW/g; SAR(10 g) = 5.45 mW/g

Maximum value of SAR (measured) = 8.18 mW/g

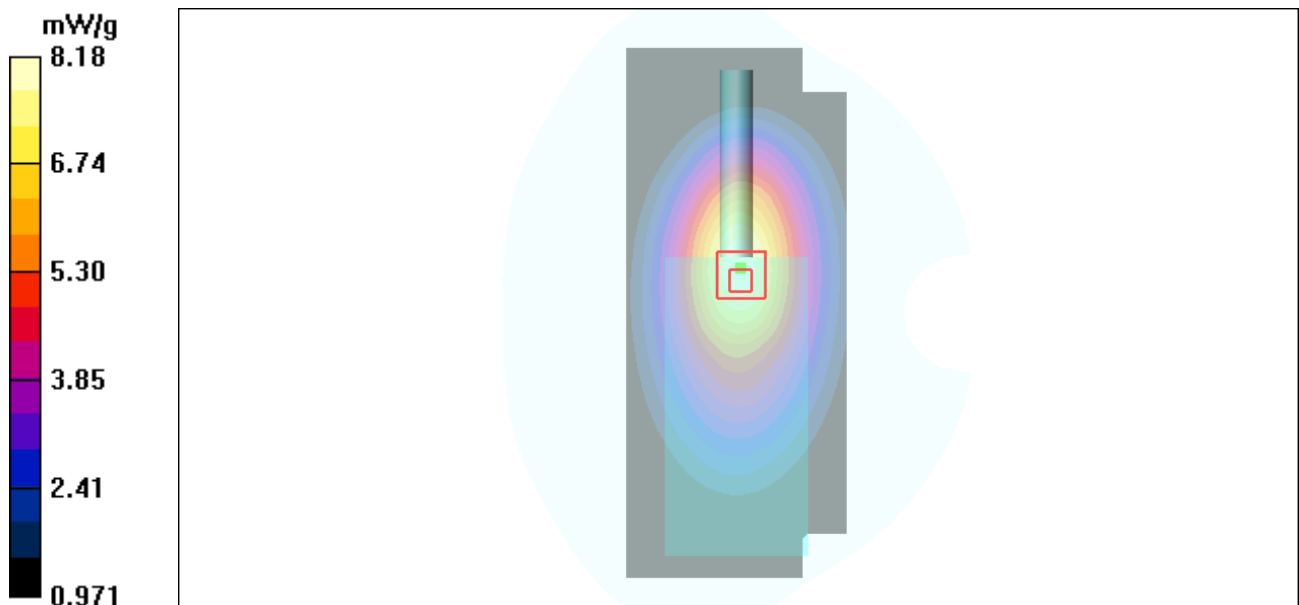

**Figure 13 Body-Worn with Thinner Battery, Belt and Accessory 1, Front towards Ground
435.5MHz (12.5 KHz Channel Spacing)**

**Body-Worn with Thinner Battery, Belt and Accessory 1, Front towards Ground
452.5MHz (12.5 KHz Channel Spacing)**

Date/Time: 3/23/2012 12:51:04 PM

Communication System: PTT 400-470; Frequency: 452.5 MHz; Duty Cycle: 1:1

Medium parameters used (interpolated): $f = 452.5$ MHz; $\sigma = 0.923$ mho/m; $\epsilon_r = 55$; $\rho = 1000$ kg/m³

Ambient Temperature: 22.3 °C Liquid Temperature: 21.5 °C

Phantom section: Flat Section

DASY4 Configuration:

Probe: EX3DV4 - SN3816; ConvF(10.83, 10.83, 10.83) Calibrated: 10/3/2011;

Electronics: DAE4 Sn871; Calibrated: 11/22/2011

Phantom: SAM 12; Type: SAM V4.0; Serial: TP-1246

Measurement SW: DASY4, V4.7 Build 80; Postprocessing SW: SEMCAD, V1.8 Build 186

Towards Ground 452.5MHz/Area Scan (51x121x1): Measurement grid: dx=15mm, dy=15mm
Maximum value of SAR (interpolated) = 7.90 mW/g

Towards Ground 452.5MHz/Zoom Scan (7x7x7)/Cube 0: Measurement grid: dx=5mm, dy=5mm,
dz=5mm

Reference Value = 88.8 V/m; Power Drift = -0.09 dB

Peak SAR (extrapolated) = 8.76 W/kg

SAR(1 g) = 5.86 mW/g; SAR(10 g) = 4.12 mW/g

Maximum value of SAR (measured) = 6.13 mW/g

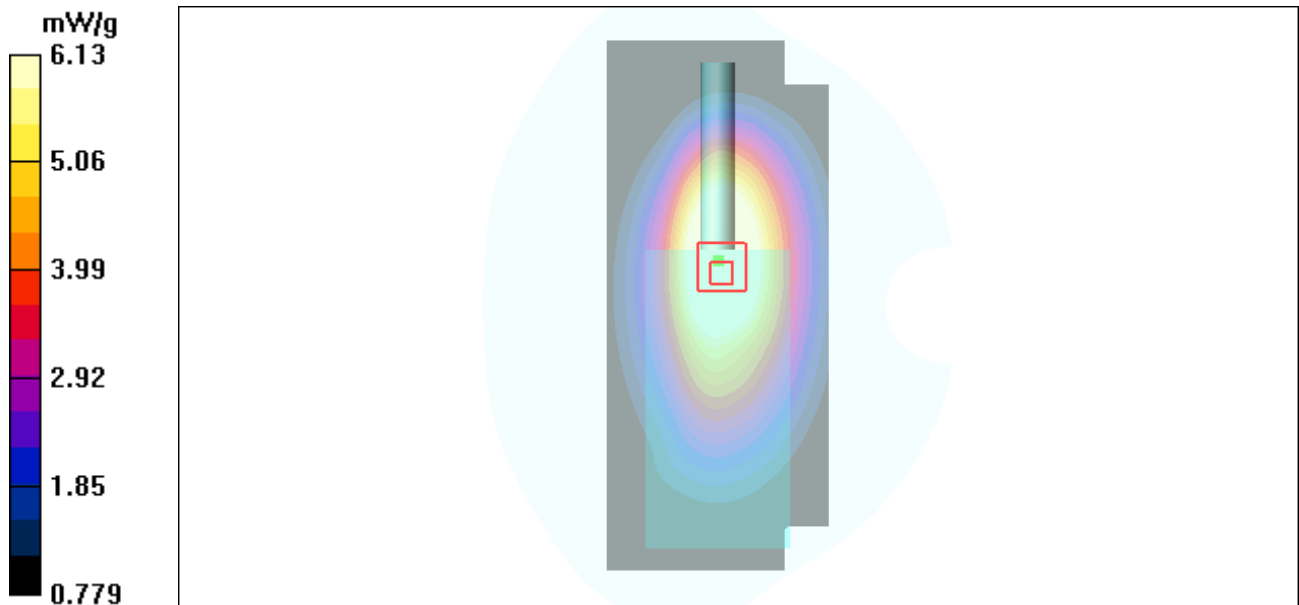

**Figure 14 Body-Worn with Thinner Battery, Belt and Accessory 1, Front towards Ground
452.5MHz (12.5 KHz Channel Spacing)**

**Body-Worn with Thinner Battery, Belt and Accessory 1, Front towards Ground
469.5MHz (12.5 KHz Channel Spacing)**

Date/Time: 3/23/2012 1:08:26 PM

Communication System: PTT 400-470; Frequency: 469.5 MHz; Duty Cycle: 1:1

Medium parameters used (interpolated): $f = 469.5$ MHz; $\sigma = 0.935$ mho/m; $\epsilon_r = 54.8$; $\rho = 1000$ kg/m³

Ambient Temperature: 22.3 °C Liquid Temperature: 21.5 °C

Phantom section: Flat Section

DASY4 Configuration:

Probe: EX3DV4 - SN3816; ConvF(10.83, 10.83, 10.83) Calibrated: 10/3/2011;

Electronics: DAE4 Sn871; Calibrated: 11/22/2011

Phantom: SAM 12; Type: SAM V4.0; Serial: TP-1246

Measurement SW: DASY4, V4.7 Build 80; Postprocessing SW: SEMCAD, V1.8 Build 186

Towards Ground 469.5MHz/Area Scan (51x121x1): Measurement grid: dx=15mm, dy=15mm
Maximum value of SAR (interpolated) = 6.37 mW/g

Towards Ground 469.5MHz/Zoom Scan (7x7x7)/Cube 0: Measurement grid: dx=5mm, dy=5mm,
dz=5mm

Reference Value = 78.8 V/m; Power Drift = -0.061 dB

Peak SAR (extrapolated) = 9.03 W/kg

SAR(1 g) = 6.01 mW/g; SAR(10 g) = 4.21 mW/g

Maximum value of SAR (measured) = 6.31 mW/g

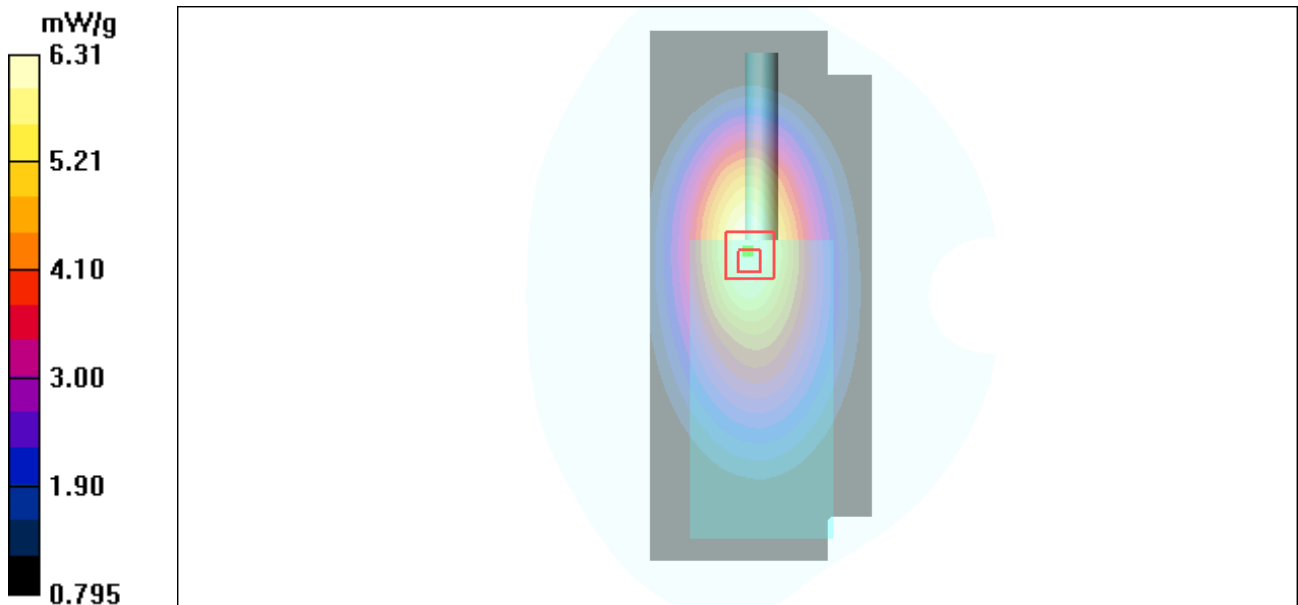

**Figure 15 Body-Worn with Thinner Battery, Belt and Accessory 1, Front towards Ground
469.5MHz (12.5 KHz Channel Spacing)**

Body-Worn with Thinner Battery, Belt, Accessory 1 and Earphone 1, Front towards Ground 400.5MHz (12.5 KHz Channel Spacing)

Date/Time: 3/27/2012 10:48:12 AM

Communication System: PTT 400-470; Frequency: 400.5 MHz; Duty Cycle: 1:1

Medium parameters used (interpolated): $f = 400.5$ MHz; $\sigma = 0.895$ mho/m; $\epsilon_r = 56.1$; $\rho = 1000$ kg/m³

Ambient Temperature: 22.3 °C Liquid Temperature: 21.5 °C

Phantom section: Flat Section

DASY4 Configuration:

Probe: EX3DV4 - SN3816; ConvF(10.83, 10.83, 10.83) Calibrated: 10/3/2011;

Electronics: DAE4 Sn871; Calibrated: 11/22/2011

Phantom: SAM 12; Type: SAM V4.0; Serial: TP-1246

Measurement SW: DASY4, V4.7 Build 80; Postprocessing SW: SEMCAD, V1.8 Build 186

Towards Ground 400.5MHz/Area Scan (51x121x1): Measurement grid: dx=15mm, dy=15mm
Maximum value of SAR (interpolated) = 9.08 mW/g

Towards Ground 400.5MHz/Zoom Scan (7x7x7)/Cube 0: Measurement grid: dx=5mm, dy=5mm, dz=5mm

Reference Value = 94.7 V/m; Power Drift = -0.127 dB

Peak SAR (extrapolated) = 12.6 W/kg

SAR(1 g) = 8.56 mW/g; SAR(10 g) = 6.08 mW/g

Maximum value of SAR (measured) = 9.01 mW/g

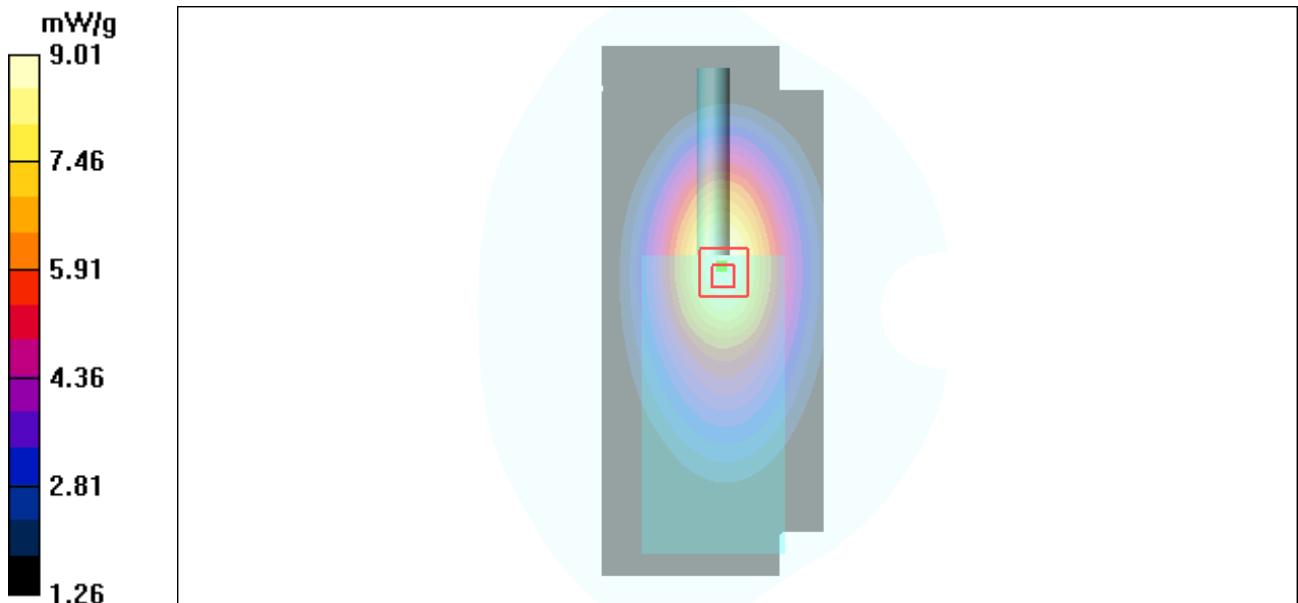

Figure 16 Body-Worn with Thinner Battery, Belt, Accessory 1 and Earphone 1, Front towards Ground 400.5MHz (12.5 KHz Channel Spacing)

TA Technology (Shanghai) Co., Ltd.
Test Report

Body-Worn with Thinner Battery, Belt, Accessory 1 and Earphone 2, Front towards Ground 400.5MHz (12.5 KHz Channel Spacing)

Date/Time: 3/27/2012 10:30:11 AM

Communication System: PTT 400-470; Frequency: 400.5 MHz; Duty Cycle: 1:1

Medium parameters used (interpolated): $f = 400.5$ MHz; $\sigma = 0.895$ mho/m; $\epsilon_r = 56.1$; $\rho = 1000$ kg/m³

Ambient Temperature: 22.3 °C Liquid Temperature: 21.5 °C

Phantom section: Flat Section

DASY4 Configuration:

Probe: EX3DV4 - SN3816; ConvF(10.83, 10.83, 10.83) Calibrated: 10/3/2011;

Electronics: DAE4 Sn871; Calibrated: 11/22/2011

Phantom: SAM 12; Type: SAM V4.0; Serial: TP-1246

Measurement SW: DASY4, V4.7 Build 80; Postprocessing SW: SEMCAD, V1.8 Build 186

Towards Ground 400.5MHz/Area Scan (51x121x1): Measurement grid: dx=15mm, dy=15mm
Maximum value of SAR (interpolated) = 9.11 mW/g

Towards Ground 400.5MHz/Zoom Scan (7x7x7)/Cube 0: Measurement grid: dx=5mm, dy=5mm, dz=5mm

Reference Value = 95.0 V/m; Power Drift = -0.024 dB

Peak SAR (extrapolated) = 12.3 W/kg

SAR(1 g) = 8.37 mW/g; SAR(10 g) = 5.97 mW/g

Maximum value of SAR (measured) = 8.81 mW/g

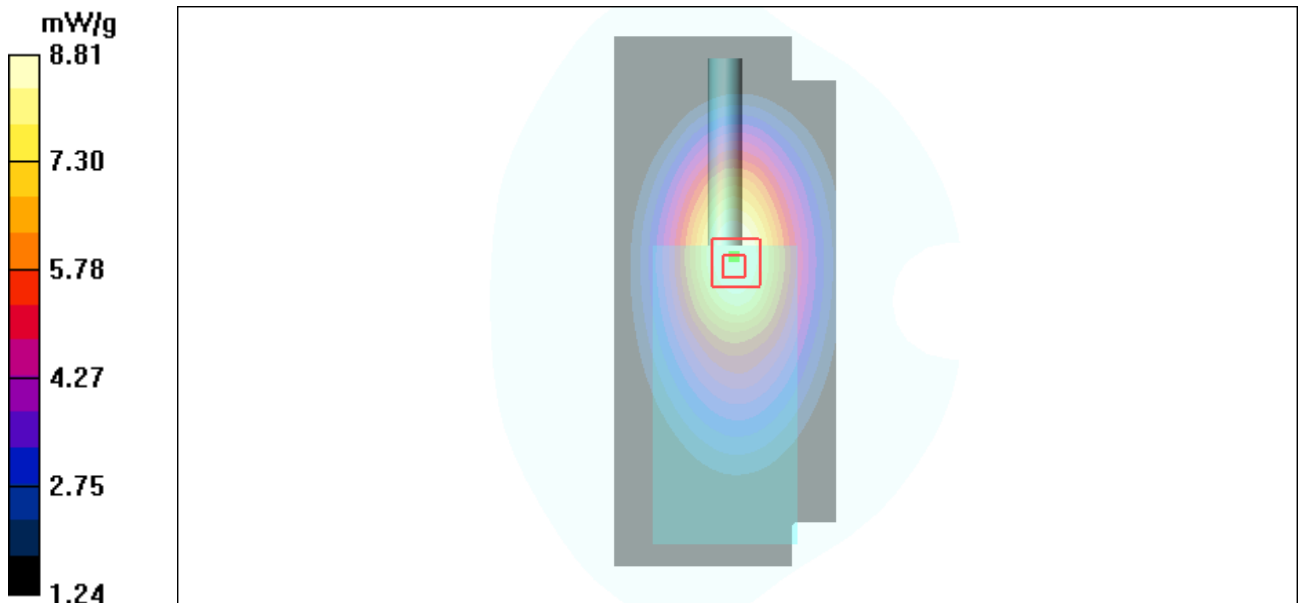

Figure 17 Body-Worn with Thinner Battery, Belt, Accessory 1 and Earphone 2, Front towards Ground 400.5MHz (12.5 KHz Channel Spacing)

TA Technology (Shanghai) Co., Ltd. Test Report

Report No. RZA1203-0315SAR

Page 45 of 100

Body-Worn with Thinner Battery, Belt and Audio Accessory 2, Front towards Ground 400.5MHz (12.5 KHz Channel Spacing)

Date/Time: 3/23/2012 1:26:55 PM

Communication System: PTT 400-470; Frequency: 400.5 MHz; Duty Cycle: 1:1

Medium parameters used (interpolated): $f = 400.5$ MHz; $\sigma = 0.895$ mho/m; $\epsilon_r = 56.1$; $\rho = 1000$ kg/m³

Ambient Temperature: 22.3 °C Liquid Temperature: 21.5 °C

Phantom section: Flat Section

DASY4 Configuration:

Probe: EX3DV4 - SN3816; ConvF(10.83, 10.83, 10.83) Calibrated: 10/3/2011;

Electronics: DAE4 Sn871; Calibrated: 11/22/2011

Phantom: SAM 12; Type: SAM V4.0; Serial: TP-1246

Measurement SW: DASY4, V4.7 Build 80; Postprocessing SW: SEMCAD, V1.8 Build 186

Towards Ground 400.5MHz/Area Scan (51x121x1): Measurement grid: dx=15mm, dy=15mm
Maximum value of SAR (interpolated) = 9.10 mW/g

Towards Ground 400.5MHz/Zoom Scan (7x7x7)/Cube 0: Measurement grid: dx=5mm, dy=5mm, dz=5mm

Reference Value = 98.0 V/m; Power Drift = -0.069 dB

Peak SAR (extrapolated) = 12.6 W/kg

SAR(1 g) = 8.59 mW/g; SAR(10 g) = 6.11 mW/g

Maximum value of SAR (measured) = 9.02 mW/g

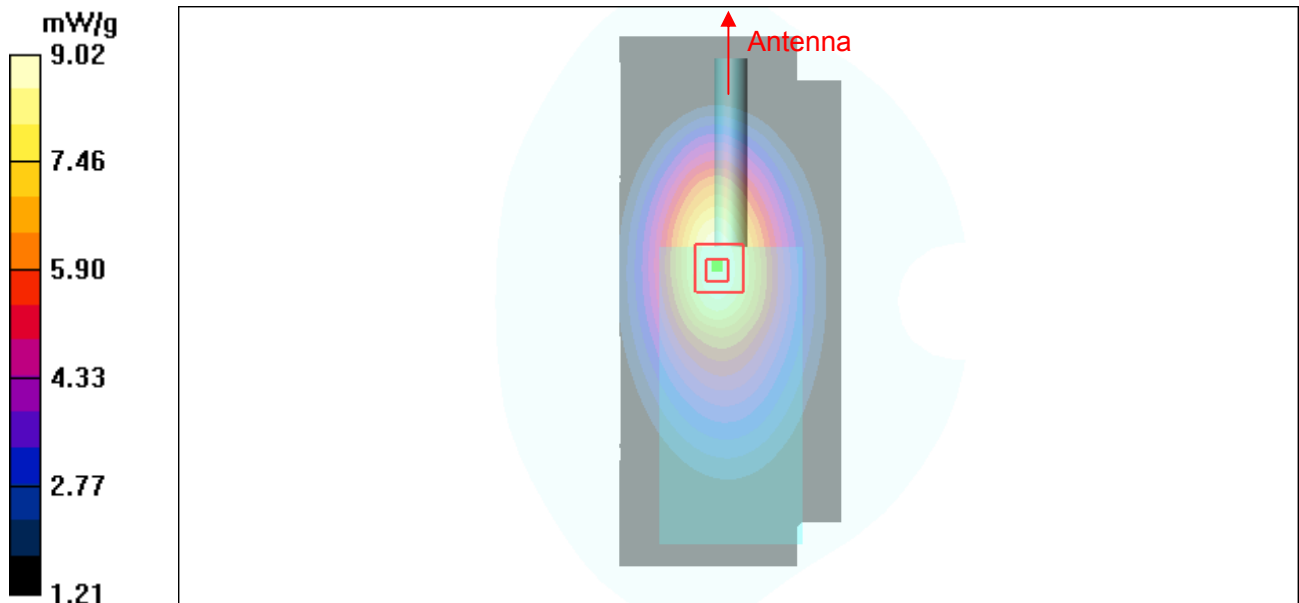

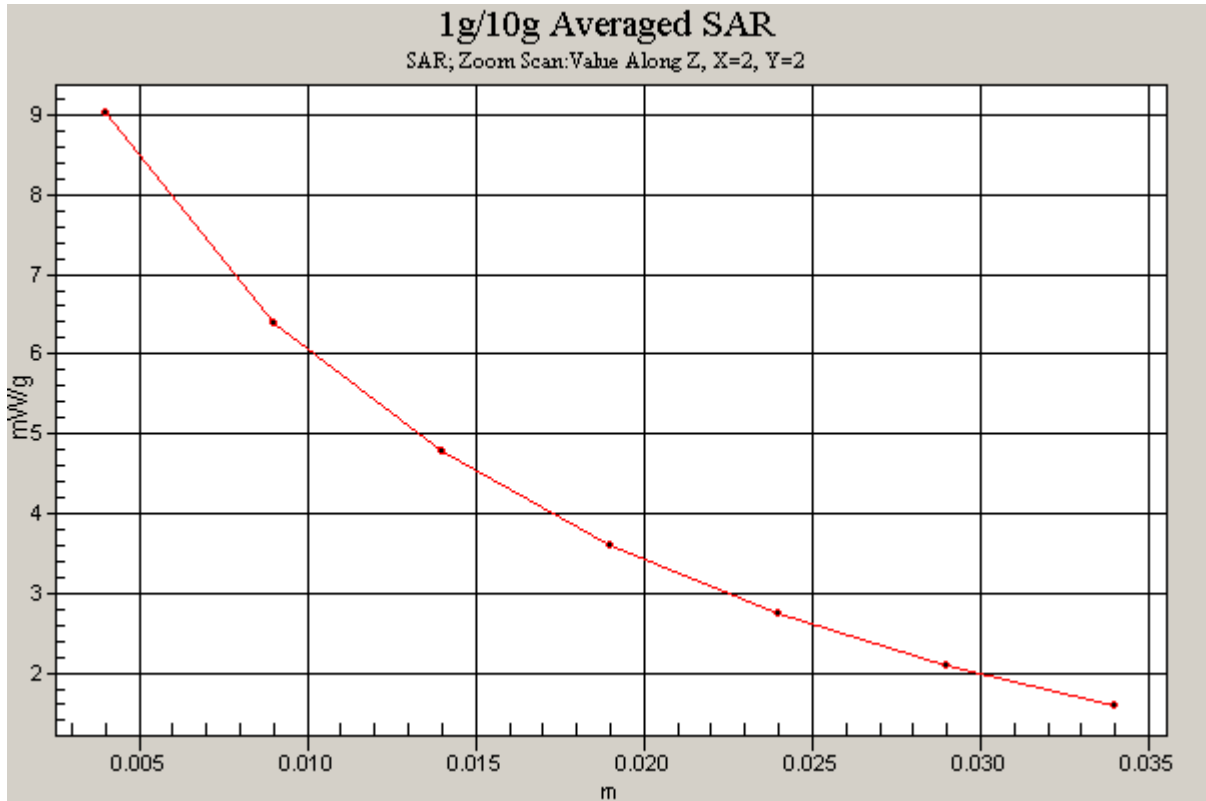

Figure 18 Body-Worn with Thinner Battery, Belt and Audio Accessory 2, Front towards Ground 400.5MHz (12.5 KHz Channel Spacing)

TA Technology (Shanghai) Co., Ltd.
Test Report

Body-Worn with Thinner Battery, Belt and Audio Accessory 3, Front towards Ground 400.5MHz (12.5 KHz Channel Spacing)

Date/Time: 3/23/2012 1:41:16 PM

Communication System: PTT 400-470; Frequency: 400.5 MHz; Duty Cycle: 1:1

Medium parameters used (interpolated): $f = 400.5$ MHz; $\sigma = 0.895$ mho/m; $\epsilon_r = 56.1$; $\rho = 1000$ kg/m³

Ambient Temperature: 22.3 °C Liquid Temperature: 21.5 °C

Phantom section: Flat Section

DASY4 Configuration:

Probe: EX3DV4 - SN3816; ConvF(10.83, 10.83, 10.83) Calibrated: 10/3/2011;

Electronics: DAE4 Sn871; Calibrated: 11/22/2011

Phantom: SAM 12; Type: SAM V4.0; Serial: TP-1246

Measurement SW: DASY4, V4.7 Build 80; Postprocessing SW: SEMCAD, V1.8 Build 186

Towards Ground 400.5MHz/Area Scan (51x121x1): Measurement grid: dx=15mm, dy=15mm
Maximum value of SAR (interpolated) = 8.33 mW/g

Towards Ground 400.5MHz/Zoom Scan (7x7x7)/Cube 0: Measurement grid: dx=5mm, dy=5mm, dz=5mm

Reference Value = 93.8 V/m; Power Drift = -0.040 dB

Peak SAR (extrapolated) = 11.8 W/kg

SAR(1 g) = 7.92 mW/g; SAR(10 g) = 5.61 mW/g

Maximum value of SAR (measured) = 8.29 mW/g

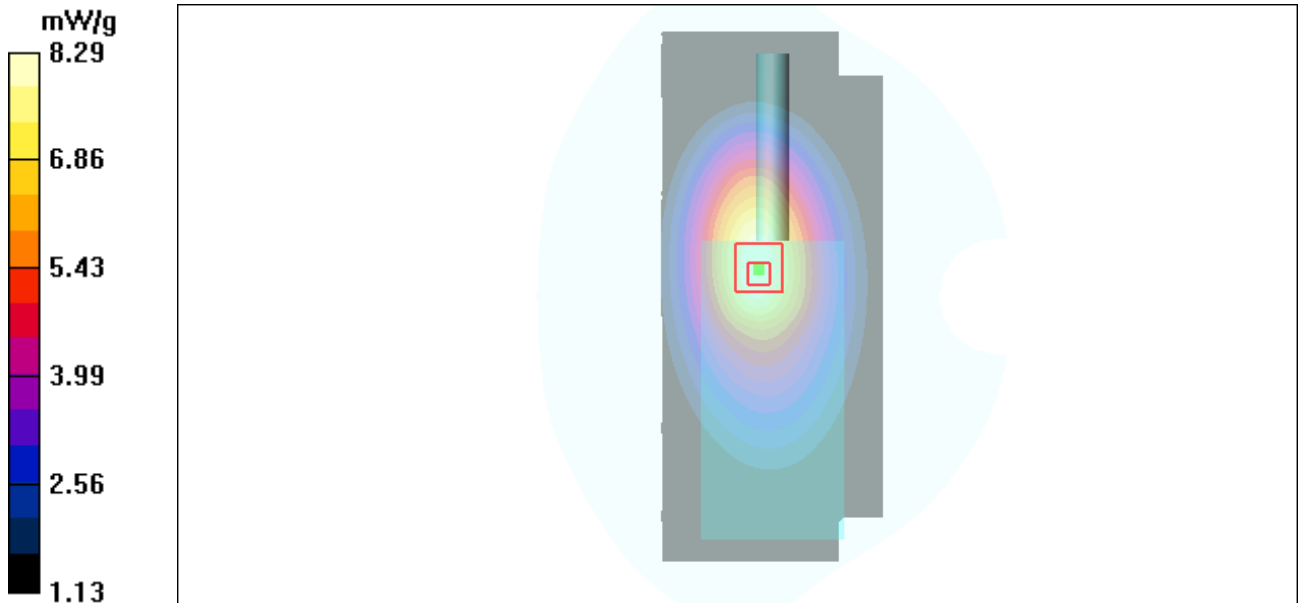

Figure 19 Body-Worn with Thinner Battery, Belt and Audio Accessory 3, Front towards Ground 400.5MHz (12.5 KHz Channel Spacing)

TA Technology (Shanghai) Co., Ltd.
Test Report

Body-Worn with Thinner Battery, Belt and Audio Accessory 4, Front towards Ground 400.5MHz (12.5 KHz Channel Spacing)

Date/Time: 3/23/2012 1:55:44 PM

Communication System: PTT 400-470; Frequency: 400.5 MHz; Duty Cycle: 1:1

Medium parameters used (interpolated): $f = 400.5$ MHz; $\sigma = 0.895$ mho/m; $\epsilon_r = 56.1$; $\rho = 1000$ kg/m³

Ambient Temperature: 22.3 °C Liquid Temperature: 21.5°C

Phantom section: Flat Section

DASY4 Configuration:

Probe: EX3DV4 - SN3816; ConvF(10.83, 10.83, 10.83) Calibrated: 10/3/2011;

Electronics: DAE4 Sn871; Calibrated: 11/22/2011

Phantom: SAM 12; Type: SAM V4.0; Serial: TP-1246

Measurement SW: DASY4, V4.7 Build 80; Postprocessing SW: SEMCAD, V1.8 Build 186

Towards Ground 400.5MHz/Area Scan (51x121x1): Measurement grid: dx=15mm, dy=15mm
Maximum value of SAR (interpolated) = 8.35 mW/g

Towards Ground 400.5MHz/Zoom Scan (7x7x7)/Cube 0: Measurement grid: dx=5mm, dy=5mm, dz=5mm

Reference Value = 94.5 V/m; Power Drift = -0.035 dB

Peak SAR (extrapolated) = 11.9 W/kg

SAR(1 g) = 7.99 mW/g; SAR(10 g) = 5.64 mW/g

Maximum value of SAR (measured) = 8.38 mW/g

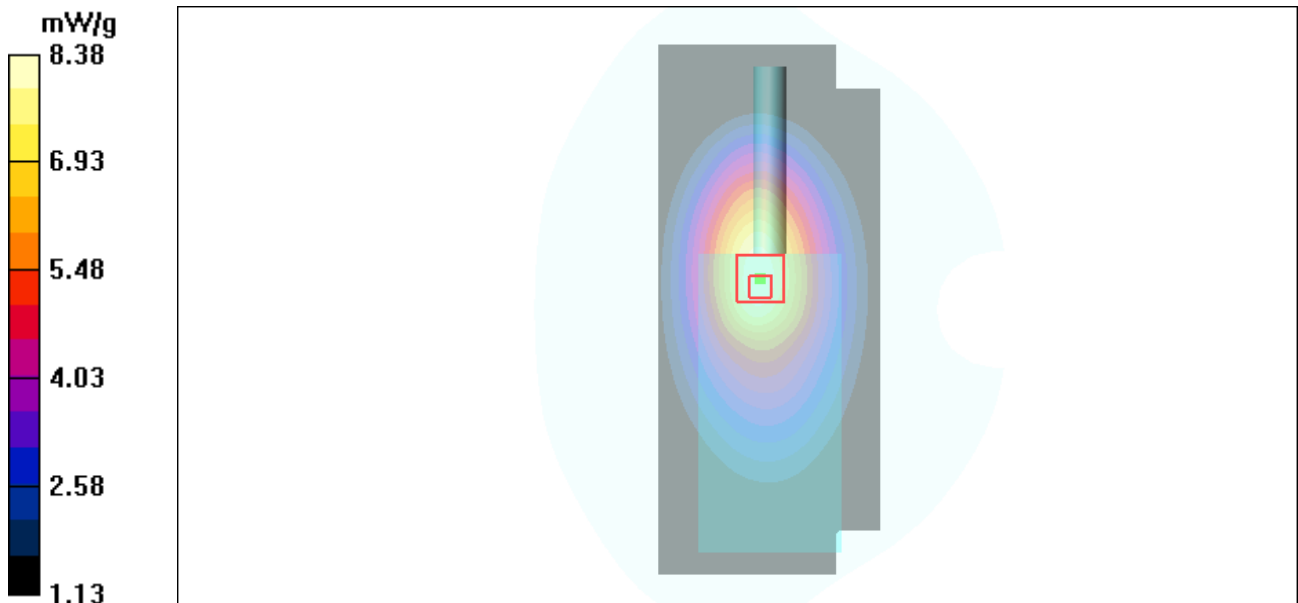

Figure 20 Body-Worn with Thinner Battery, Belt and Audio Accessory 4, Front towards Ground 400.5MHz (12.5 KHz Channel Spacing)

Body-Worn with Thinner Battery, Belt and Audio Accessory 5, Front towards Ground 400.5MHz (12.5 KHz Channel Spacing)

Date/Time: 3/23/2012 2:11:33 PM

Communication System: PTT 400-470; Frequency: 400.5 MHz; Duty Cycle: 1:1

Medium parameters used (interpolated): $f = 400.5$ MHz; $\sigma = 0.895$ mho/m; $\epsilon_r = 56.1$; $\rho = 1000$ kg/m³

Ambient Temperature: 22.3 °C Liquid Temperature: 21.5 °C

Phantom section: Flat Section

DASY4 Configuration:

Probe: EX3DV4 - SN3816; ConvF(10.83, 10.83, 10.83) Calibrated: 10/3/2011;

Electronics: DAE4 Sn871; Calibrated: 11/22/2011

Phantom: SAM 12; Type: SAM V4.0; Serial: TP-1246

Measurement SW: DASY4, V4.7 Build 80; Postprocessing SW: SEMCAD, V1.8 Build 186

Towards Ground 400.5MHz/Area Scan (51x121x1): Measurement grid: dx=15mm, dy=15mm
Maximum value of SAR (interpolated) = 8.59 mW/g

Towards Ground 400.5MHz/Zoom Scan (7x7x7)/Cube 0: Measurement grid: dx=5mm, dy=5mm, dz=5mm

Reference Value = 96.2 V/m; Power Drift = -0.016 dB

Peak SAR (extrapolated) = 12.0 W/kg

SAR(1 g) = 8.2 mW/g; SAR(10 g) = 5.84 mW/g

Maximum value of SAR (measured) = 8.53 mW/g

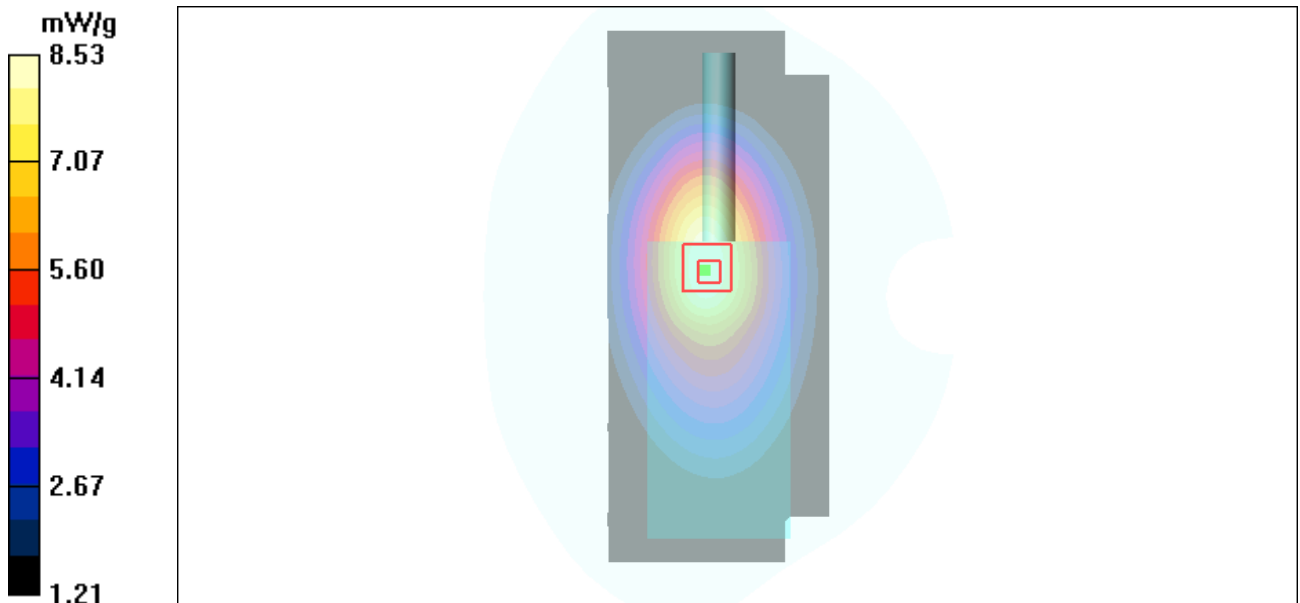

Figure 21 Body-Worn KHz with Thinner Battery, Belt and Audio Accessory 5, Front towards Ground 400.5MHz (12.5 KHz Channel Spacing)

**Body-Worn with Thinner Battery, Pocket and Accessory 1, Front towards Ground
400.5MHz (12.5 KHz Channel Spacing)**

Date/Time: 3/23/2012 10:32:02 AM

Communication System: PTT 400-470; Frequency: 400.5 MHz; Duty Cycle: 1:1

Medium parameters used (interpolated): $f = 400.5$ MHz; $\sigma = 0.895$ mho/m; $\epsilon_r = 56.1$; $\rho = 1000$ kg/m³

Ambient Temperature: 22.3 °C Liquid Temperature: 21.5 °C

Phantom section: Flat Section

DASY4 Configuration:

Probe: EX3DV4 - SN3816; ConvF(10.83, 10.83, 10.83) Calibrated: 10/3/2011;

Electronics: DAE4 Sn871; Calibrated: 11/22/2011

Phantom: SAM 12; Type: SAM V4.0; Serial: TP-1246

Measurement SW: DASY4, V4.7 Build 80; Postprocessing SW: SEMCAD, V1.8 Build 186

Towards Ground 400.5MHz/Area Scan (51x121x1): Measurement grid: dx=15mm, dy=15mm
Maximum value of SAR (interpolated) = 8.38 mW/g

Towards Ground 400.5MHz/Zoom Scan (7x7x7)/Cube 0: Measurement grid: dx=5mm, dy=5mm,
dz=5mm

Reference Value = 99.0 V/m; Power Drift = -0.072 dB

Peak SAR (extrapolated) = 12.1 W/kg

SAR(1 g) = 8.04 mW/g; SAR(10 g) = 5.65 mW/g

Maximum value of SAR (measured) = 8.46 mW/g

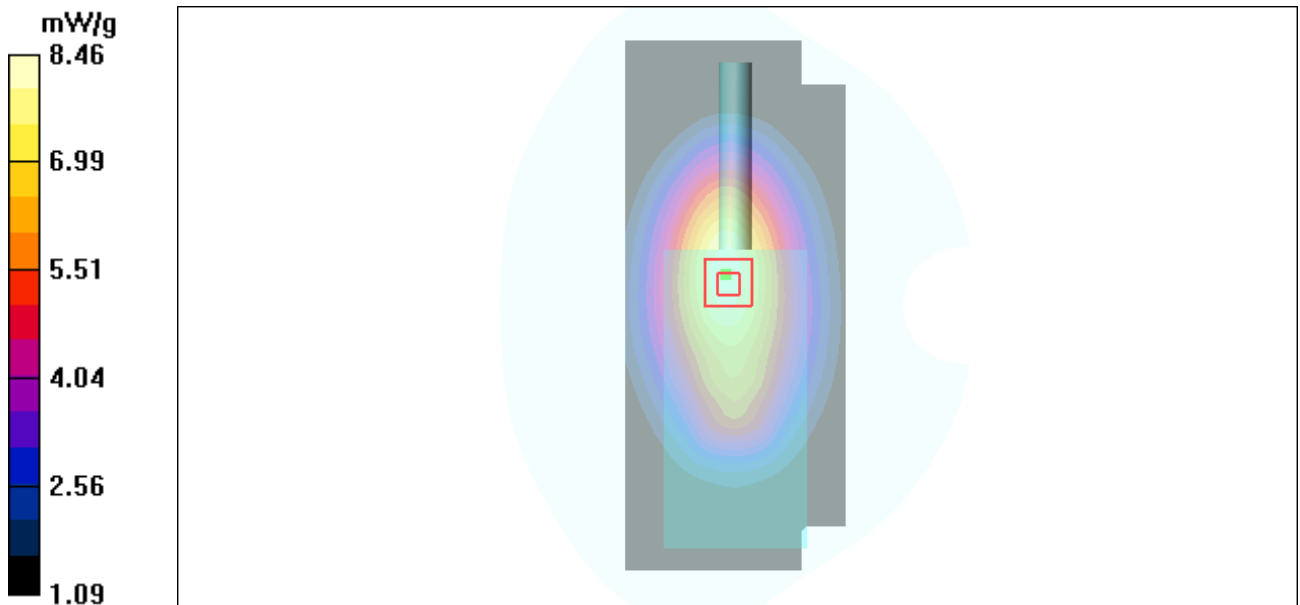

**Figure 22 Body-Worn with Thinner Battery, Pocket and Accessory 1, Front towards Ground
400.5MHz (12.5 KHz Channel Spacing)**

TA Technology (Shanghai) Co., Ltd.
Test Report

Body-Worn with Thinner Battery, Pocket, Leather and Accessory 1, Front towards Ground 400.5MHz (12.5 KHz Channel Spacing)

Date/Time: 3/26/2012 3:39:00 PM

Communication System: PTT 400-470; Frequency: 400.5 MHz; Duty Cycle: 1:1

Medium parameters used (interpolated): $f = 400.5$ MHz; $\sigma = 0.895$ mho/m; $\epsilon_r = 56.1$; $\rho = 1000$ kg/m³

Ambient Temperature: 22.3 °C Liquid Temperature: 21.5 °C

Phantom section: Flat Section

DASY4 Configuration:

Probe: EX3DV4 - SN3816; ConvF(10.83, 10.83, 10.83) Calibrated: 10/3/2011;

Electronics: DAE4 Sn871; Calibrated: 11/22/2011

Phantom: SAM 12; Type: SAM V4.0; Serial: TP-1246

Measurement SW: DASY4, V4.7 Build 80; Postprocessing SW: SEMCAD, V1.8 Build 186

Towards Ground 400.5MHz/Area Scan (51x121x1): Measurement grid: dx=15mm, dy=15mm
Maximum value of SAR (interpolated) = 5.30 mW/g

Towards Ground 400.5MHz/Zoom Scan (7x7x7)/Cube 0: Measurement grid: dx=5mm, dy=5mm, dz=5mm

Reference Value = 76.2 V/m; Power Drift = 0.042 dB

Peak SAR (extrapolated) = 7.05 W/kg

SAR(1 g) = 5.1 mW/g; SAR(10 g) = 3.81 mW/g

Maximum value of SAR (measured) = 5.33 mW/g

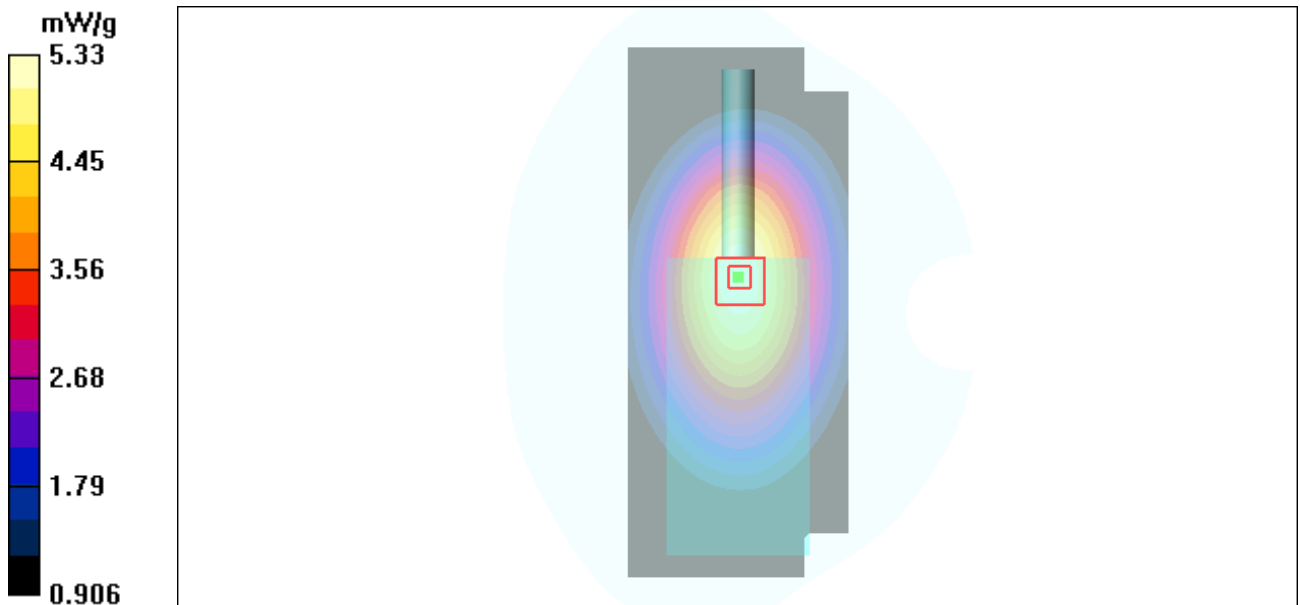

Figure 23 Body-Worn with Thinner Battery, Pocket, Leather and Accessory 1, Front towards Ground 400.5MHz (12.5 KHz Channel Spacing)

Body-Worn for Digital with Thinner Battery, Belt and Audio Accessory 2, Front towards Ground 400.5MHz

Date/Time: 3/23/2012 2:28:52 PM

Communication System: PTT 400-470; Frequency: 400.5 MHz; Duty Cycle: 1:2

Medium parameters used (interpolated): $f = 400.5$ MHz; $\sigma = 0.895$ mho/m; $\epsilon_r = 56.1$; $\rho = 1000$ kg/m³

Ambient Temperature: 22.3 °C Liquid Temperature: 21.5 °C

Phantom section: Flat Section

DASY4 Configuration:

Probe: EX3DV4 - SN3816; ConvF(10.83, 10.83, 10.83) Calibrated: 10/3/2011;

Electronics: DAE4 Sn871; Calibrated: 11/22/2011

Phantom: SAM 12; Type: SAM V4.0; Serial: TP-1246

Measurement SW: DASY4, V4.7 Build 80; Postprocessing SW: SEMCAD, V1.8 Build 186

Towards Ground 400.5MHz/Area Scan (51x121x1): Measurement grid: dx=15mm, dy=15mm
Maximum value of SAR (interpolated) = 3.89 mW/g

Towards Ground 400.5MHz/Zoom Scan (7x7x7)/Cube 0: Measurement grid: dx=5mm, dy=5mm, dz=5mm

Reference Value = 63.4 V/m; Power Drift = -0.171 dB

Peak SAR (extrapolated) = 5.70 W/kg

SAR(1 g) = 3.68 mW/g; SAR(10 g) = 2.57 mW/g

Maximum value of SAR (measured) = 3.89 mW/g

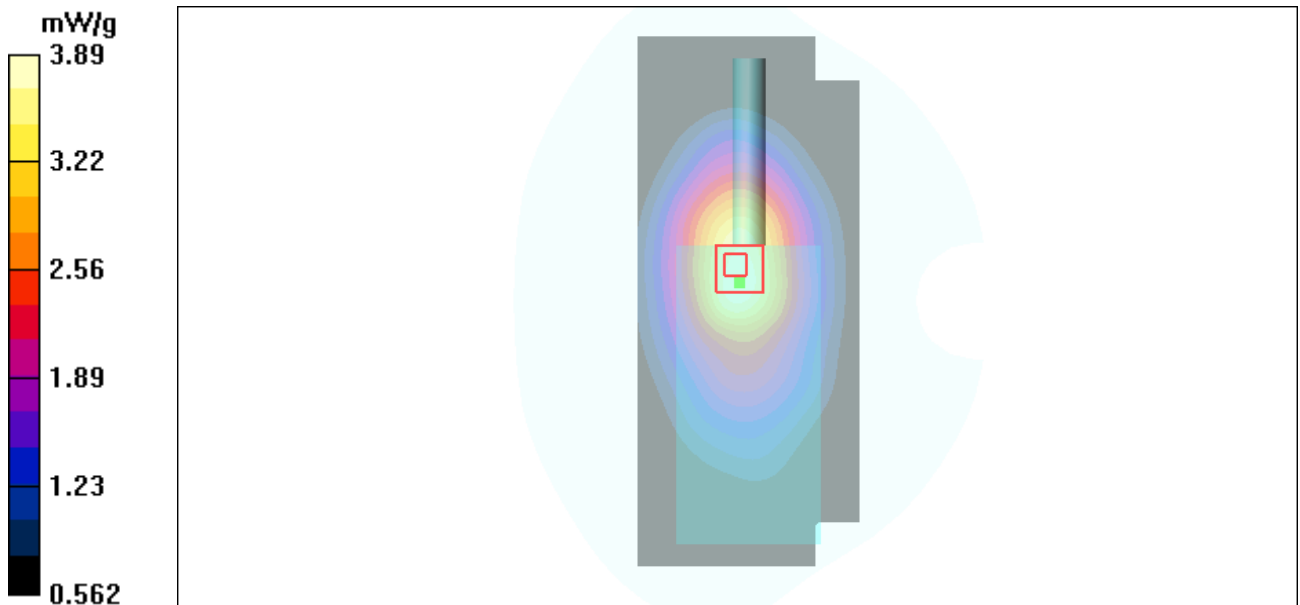

Figure 24 Body-Worn for Digital with Thinner Battery, Belt and Audio Accessory 2, Front towards Ground 400.5MHz

Body-Worn with Thicker Battery, Belt and Audio Accessory 2, Front towards Ground with Digital 400.5MHz (12.5 KHz Channel Spacing)

Date/Time: 3/23/2012 2:54:39 PM

Communication System: PTT 400-470; Frequency: 400.5 MHz; Duty Cycle: 1:1

Medium parameters used (interpolated): $f = 400.5$ MHz; $\sigma = 0.895$ mho/m; $\epsilon_r = 56.1$; $\rho = 1000$ kg/m³

Ambient Temperature: 22.3 °C Liquid Temperature: 21.5 °C

Phantom section: Flat Section

DASY4 Configuration:

Probe: EX3DV4 - SN3816; ConvF(10.83, 10.83, 10.83) Calibrated: 10/3/2011;

Electronics: DAE4 Sn871; Calibrated: 11/22/2011

Phantom: SAM 12; Type: SAM V4.0; Serial: TP-1246

Measurement SW: DASY4, V4.7 Build 80; Postprocessing SW: SEMCAD, V1.8 Build 186

Towards Ground 400.5MHz/Area Scan (51x121x1): Measurement grid: dx=15mm, dy=15mm
Maximum value of SAR (interpolated) = 8.81 mW/g

Towards Ground 400.5MHz/Zoom Scan (7x7x7)/Cube 0: Measurement grid: dx=5mm, dy=5mm, dz=5mm

Reference Value = 98.8 V/m; Power Drift = -0.058 dB

Peak SAR (extrapolated) = 12.2 W/kg

SAR(1 g) = 8.36 mW/g; SAR(10 g) = 5.97 mW/g

Maximum value of SAR (measured) = 8.78 mW/g

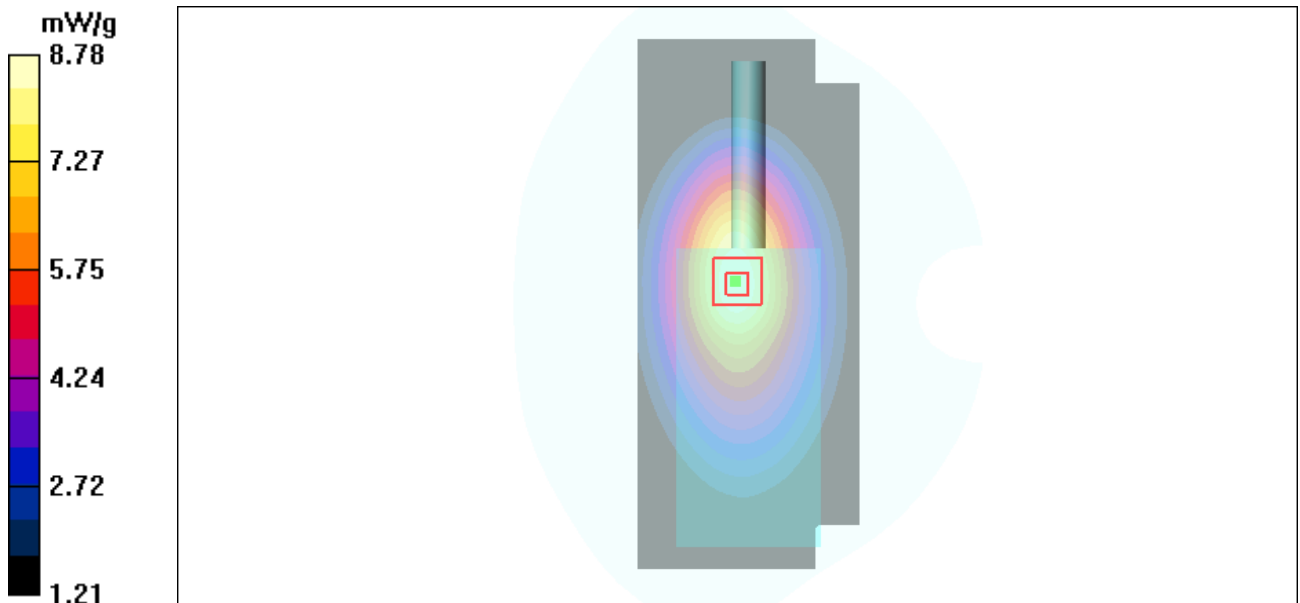

Figure 25 Body-Worn with Thicker Battery, Belt and Audio Accessory 2, Front towards Ground with Digital 400.5MHz (12.5 KHz Channel Spacing)

TA Technology (Shanghai) Co., Ltd. Test Report

Report No. RZA1203-0315SAR

Page 54 of 100

ANNEX D: Probe Calibration Certificate

**Calibration Laboratory of
Schmid & Partner
Engineering AG**
Zeughausstrasse 43, 8004 Zurich, Switzerland



S Schweizerischer Kalibrierdienst
C Service suisse d'étalonnage
S Servizio svizzero di taratura
S Swiss Calibration Service

Accredited by the Swiss Accreditation Service (SAS)
The Swiss Accreditation Service is one of the signatories to the EA
Multilateral Agreement for the recognition of calibration certificates

Accreditation No.: **SCS 108**

Client **TMC Shanghai (Auden)**

Certificate No: **EX3-3816_Oct11**

CALIBRATION CERTIFICATE

Object **EX3DV4 - SN:3816**

Calibration procedure(s) **QA CAL-01.v8, QA CAL-12.v7, QA CAL-23.v4, QA CAL-25.v4
Calibration procedure for dosimetric E-field probes**

Calibration date: **October 3, 2011**

This calibration certificate documents the traceability to national standards, which realize the physical units of measurements (SI).
The measurements and the uncertainties with confidence probability are given on the following pages and are part of the certificate.

All calibrations have been conducted in the closed laboratory facility: environment temperature (22 ± 3)°C and humidity < 70%.

Calibration Equipment used (M&TE critical for calibration)

Primary Standards	ID	Cal Date (Certificate No.)	Scheduled Calibration
Power meter E4419B	GB41293874	31-Mar-11 (No. 217-01372)	Apr-12
Power sensor E4412A	MY41498087	31-Mar-11 (No. 217-01372)	Apr-12
Reference 3 dB Attenuator	SN: S5054 (3c)	29-Mar-11 (No. 217-01389)	Apr-12
Reference 20 dB Attenuator	SN: S5086 (20b)	29-Mar-11 (No. 217-01367)	Apr-12
Reference 30 dB Attenuator	SN: S5129 (30b)	29-Mar-11 (No. 217-01370)	Apr-12
Reference Probe ES3DV2	SN: 3013	29-Dec-10 (No. ES3-3013_Dec10)	Dec-11
DAE4	SN: 654	3-May-11 (No. DAE4-654_May11)	May-12
Secondary Standards	ID	Check Date (In house)	Scheduled Check
RF generator HP 8648C	US3642U01700	4-Aug-99 (in house check Oct-09)	In house check: Oct-11
Network Analyzer HP 8753E	US37390585	18-Oct-01 (in house check Oct-10)	In house check: Oct-11

Calibrated by:	Name Jeton Kastrati	Function Laboratory Technician	Signature
Approved by:	Name Katja Pokovic	Technical Manager	

Issued: October 3, 2011

This calibration certificate shall not be reproduced except in full without written approval of the laboratory.

**Calibration Laboratory of
Schmid & Partner
Engineering AG**
Zeughausstrasse 43, 8004 Zurich, Switzerland



S Schweizerischer Kalibrierdienst
C Service suisse d'étalonnage
S Servizio svizzero di taratura
S Swiss Calibration Service

Accredited by the Swiss Accreditation Service (SAS)
The Swiss Accreditation Service is one of the signatories to the EA
Multilateral Agreement for the recognition of calibration certificates

Accreditation No.: **SCS 108**

Glossary:

TSL	tissue simulating liquid
NORM _{x,y,z}	sensitivity in free space
ConvF	sensitivity in TSL / NORM _{x,y,z}
DCP	diode compression point
CF	crest factor (1/duty_cycle) of the RF signal
A, B, C	modulation dependent linearization parameters
Polarization φ	φ rotation around probe axis
Polarization ϑ	ϑ rotation around an axis that is in the plane normal to probe axis (at measurement center), i.e., $\vartheta = 0$ is normal to probe axis

Calibration is Performed According to the Following Standards:

- a) IEEE Std 1528-2003, "IEEE Recommended Practice for Determining the Peak Spatial-Averaged Specific Absorption Rate (SAR) in the Human Head from Wireless Communications Devices: Measurement Techniques", December 2003
- b) IEC 62209-1, "Procedure to measure the Specific Absorption Rate (SAR) for hand-held devices used in close proximity to the ear (frequency range of 300 MHz to 3 GHz)", February 2005

Methods Applied and Interpretation of Parameters:

- **NORM_{x,y,z}**: Assessed for E-field polarization $\vartheta = 0$ ($f \leq 900$ MHz in TEM-cell; $f > 1800$ MHz: R22 waveguide). NORM_{x,y,z} are only intermediate values, i.e., the uncertainties of NORM_{x,y,z} does not affect the E²-field uncertainty inside TSL (see below ConvF).
- **NORM(f)_{x,y,z}** = NORM_{x,y,z} * frequency_response (see Frequency Response Chart). This linearization is implemented in DASY4 software versions later than 4.2. The uncertainty of the frequency response is included in the stated uncertainty of ConvF.
- **DCP_{x,y,z}**: DCP are numerical linearization parameters assessed based on the data of power sweep with CW signal (no uncertainty required). DCP does not depend on frequency nor media.
- **PAR**: PAR is the Peak to Average Ratio that is not calibrated but determined based on the signal characteristics
- **A_{x,y,z}; B_{x,y,z}; C_{x,y,z}; VR_{x,y,z}**: A, B, C are numerical linearization parameters assessed based on the data of power sweep for specific modulation signal. The parameters do not depend on frequency nor media. VR is the maximum calibration range expressed in RMS voltage across the diode.
- **ConvF and Boundary Effect Parameters**: Assessed in flat phantom using E-field (or Temperature Transfer Standard for $f \leq 800$ MHz) and inside waveguide using analytical field distributions based on power measurements for $f > 800$ MHz. The same setups are used for assessment of the parameters applied for boundary compensation (alpha, depth) of which typical uncertainty values are given. These parameters are used in DASY4 software to improve probe accuracy close to the boundary. The sensitivity in TSL corresponds to NORM_{x,y,z} * ConvF whereby the uncertainty corresponds to that given for ConvF. A frequency dependent ConvF is used in DASY version 4.4 and higher which allows extending the validity from ± 50 MHz to ± 100 MHz.
- **Spherical isotropy (3D deviation from isotropy)**: in a field of low gradients realized using a flat phantom exposed by a patch antenna.
- **Sensor Offset**: The sensor offset corresponds to the offset of virtual measurement center from the probe tip (on probe axis). No tolerance required.

EX3DV4 – SN:3816

October 3, 2011

Probe EX3DV4

SN:3816

Manufactured: September 2, 2011
Calibrated: October 3, 2011

Calibrated for DASY/EASY Systems
(Note: non-compatible with DASY2 system!)

TA Technology (Shanghai) Co., Ltd. Test Report

EX3DV4- SN:3816

October 3, 2011

DASY/EASY - Parameters of Probe: EX3DV4 - SN:3816

Basic Calibration Parameters

	Sensor X	Sensor Y	Sensor Z	Unc (k=2)
Norm ($\mu\text{V}/(\text{V}/\text{m})^{\text{E}^{\text{A}}}$)	0.48	0.56	0.61	$\pm 10.1\%$
DCP (mV) ^B	99.8	102.2	102.1	

Modulation Calibration Parameters

UID	Communication System Name	PAR		A dB	B dB	C dB	VR mV	Unc ^E (k=2)
10000	CW	0.00	X	0.00	0.00	1.00	111.3	$\pm 2.7\%$
			Y	0.00	0.00	1.00	127.3	
			Z	0.00	0.00	1.00	127.7	

The reported uncertainty of measurement is stated as the standard uncertainty of measurement multiplied by the coverage factor $k=2$, which for a normal distribution corresponds to a coverage probability of approximately 95%.

^A The uncertainties of NormX,Y,Z do not affect the E²-field uncertainty inside TSL (see Pages 5 and 6).

^B Numerical linearization parameter: uncertainty not required.

^E Uncertainty is determined using the max. deviation from linear response applying rectangular distribution and is expressed for the square of the field value.

TA Technology (Shanghai) Co., Ltd.
Test Report

EX3DV4- SN:3816

October 3, 2011

DASY/EASY - Parameters of Probe: EX3DV4 - SN:3816

Calibration Parameter Determined in Head Tissue Simulating Media

f (MHz) ^c	Relative Permittivity ^f	Conductivity (S/m) ^f	ConvF X	ConvF Y	ConvF Z	Alpha	Depth (mm)	Unct. (k=2)
450	43.5	0.87	9.97	9.97	9.97	0.11	1.00	± 13.4 %
750	41.9	0.89	9.47	9.47	9.47	0.62	0.78	± 12.0 %
835	41.5	0.90	9.22	9.22	9.22	0.76	0.66	± 12.0 %
1450	40.5	1.20	8.58	8.58	8.58	0.65	0.77	± 12.0 %
1750	40.1	1.37	8.23	8.23	8.23	0.80	0.58	± 12.0 %
1900	40.0	1.40	7.90	7.90	7.90	0.80	0.57	± 12.0 %
2450	39.2	1.80	7.17	7.17	7.17	0.66	0.64	± 12.0 %
2600	39.0	1.96	7.06	7.06	7.06	0.64	0.67	± 12.0 %

^c Frequency validity of ± 100 MHz only applies for DASY v4.4 and higher (see Page 2), else it is restricted to ± 50 MHz. The uncertainty is the RSS of the ConvF uncertainty at calibration frequency and the uncertainty for the indicated frequency band.

^f At frequencies below 3 GHz, the validity of tissue parameters (ϵ and σ) can be relaxed to ± 10% if liquid compensation formula is applied to measured SAR values. At frequencies above 3 GHz, the validity of tissue parameters (ϵ and σ) is restricted to ± 5%. The uncertainty is the RSS of the ConvF uncertainty for indicated target tissue parameters.

EX3DV4- SN:3816

October 3, 2011

DASY/EASY - Parameters of Probe: EX3DV4 - SN:3816

Calibration Parameter Determined in Body Tissue Simulating Media

f (MHz) ^C	Relative Permittivity ^F	Conductivity (S/m) ^F	ConvF X	ConvF Y	ConvF Z	Alpha	Depth (mm)	Unct. (k=2)
450	56.7	0.94	10.83	10.83	10.83	0.02	1.00	± 13.4 %
750	55.5	0.96	9.50	9.50	9.50	0.80	0.70	± 12.0 %
835	55.2	0.97	9.38	9.38	9.38	0.68	0.69	± 12.0 %
1750	53.4	1.49	7.80	7.80	7.80	0.80	0.65	± 12.0 %
1900	53.3	1.52	7.51	7.51	7.51	0.80	0.65	± 12.0 %
2450	52.7	1.95	7.19	7.19	7.19	0.80	0.60	± 12.0 %
2600	52.5	2.16	7.14	7.14	7.14	0.80	0.59	± 12.0 %

^C Frequency validity of ± 100 MHz only applies for DASY v4.4 and higher (see Page 2), else it is restricted to ± 50 MHz. The uncertainty is the RSS of the ConvF uncertainty at calibration frequency and the uncertainty for the indicated frequency band.

^F At frequencies below 3 GHz, the validity of tissue parameters (ϵ and σ) can be relaxed to ± 10% if liquid compensation formula is applied to measured SAR values. At frequencies above 3 GHz, the validity of tissue parameters (ϵ and σ) is restricted to ± 5%. The uncertainty is the RSS of the ConvF uncertainty for indicated target tissue parameters.

EX3DV4- SN:3816

October 3, 2011

Frequency Response of E-Field (TEM-Cell: ifi110 EXX, Waveguide: R22)

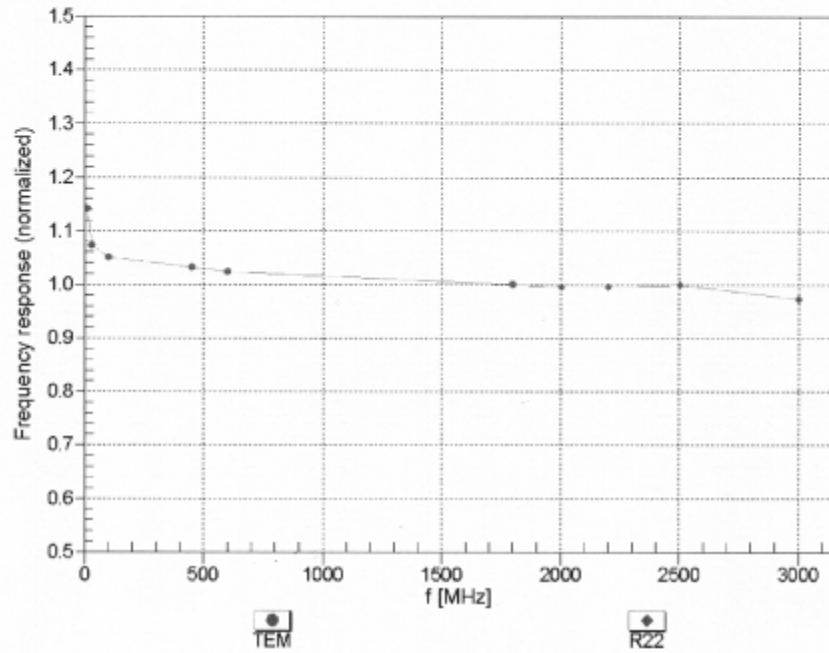

Uncertainty of Frequency Response of E-field: $\pm 6.3\%$ ($k=2$)

EX3DV4-SN:3816

October 3, 2011

Receiving Pattern (ϕ), $\theta = 0^\circ$

f=600 MHz,TEM

f=1800 MHz,R22

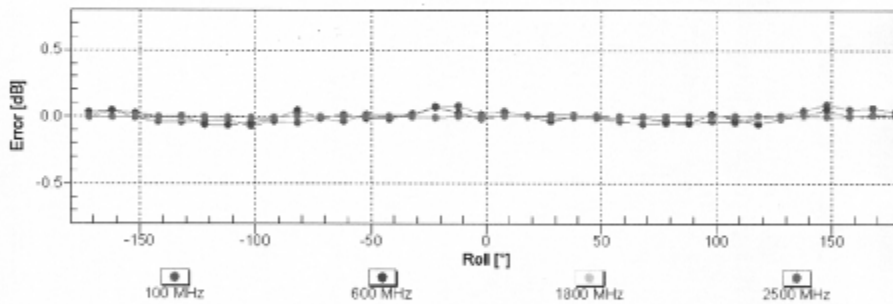
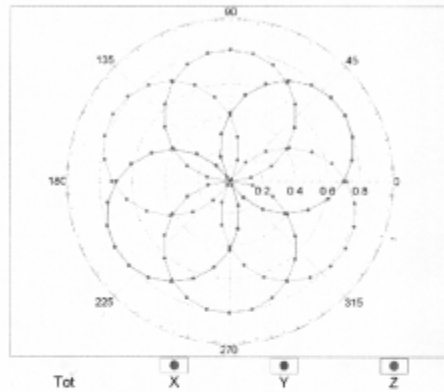
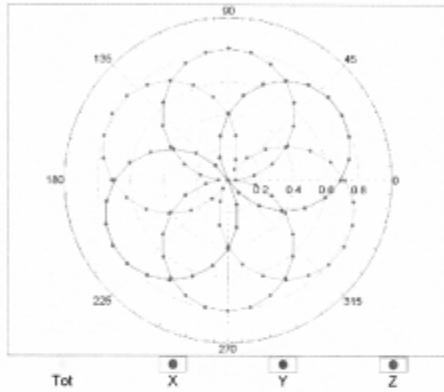

Uncertainty of Axial Isotropy Assessment: $\pm 0.5\%$ (k=2)

EX3DV4- SN:3816

October 3, 2011

Dynamic Range f(SAR_{head})
 (TEM cell , f = 900 MHz)

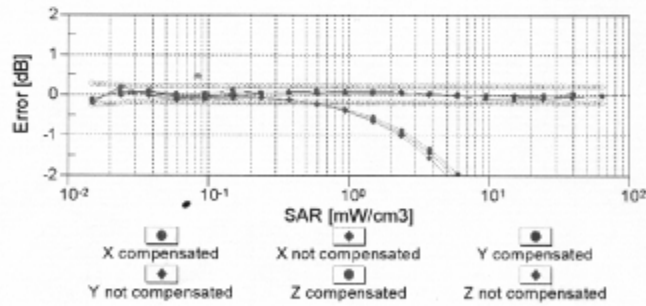
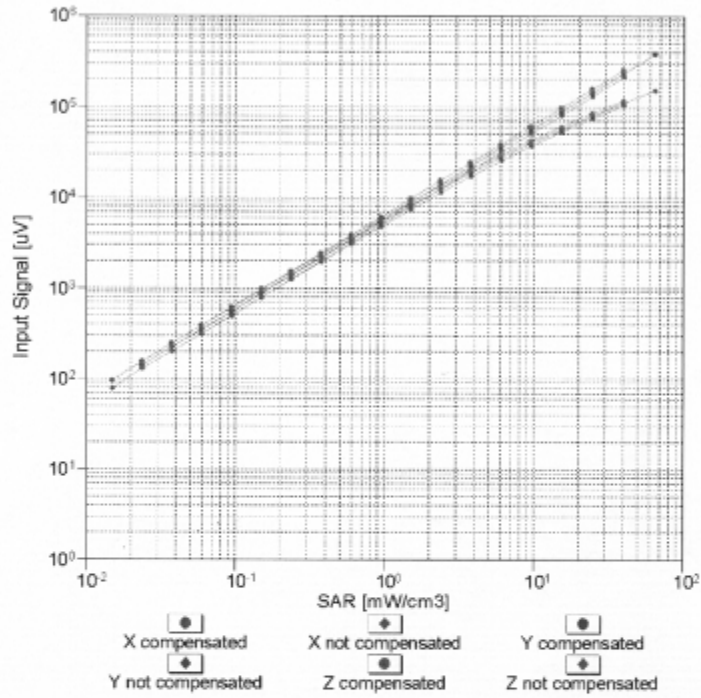

Uncertainty of Linearity Assessment: ± 0.6% (k=2)

EX3DV4- SN:3816

October 3, 2011

Conversion Factor Assessment

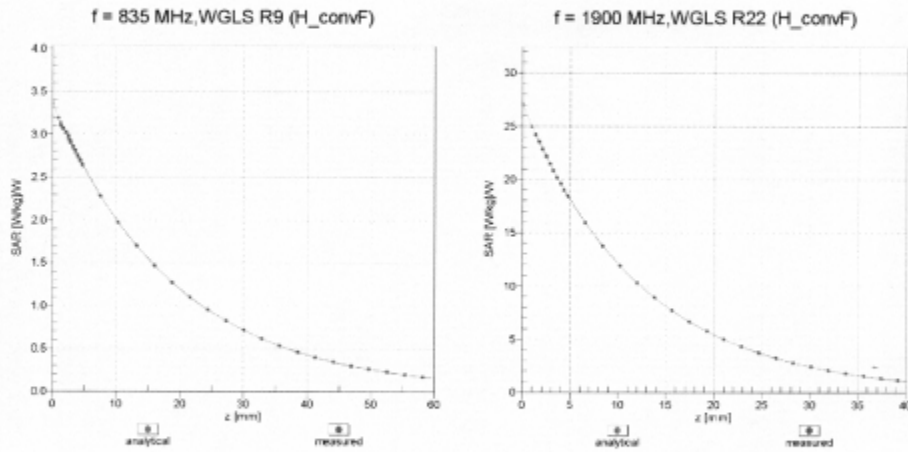

Deviation from Isotropy in Liquid Error (ϕ , θ), f = 900 MHz

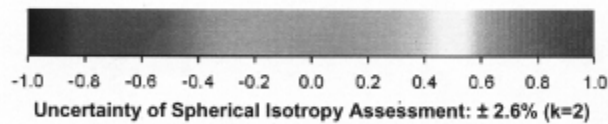
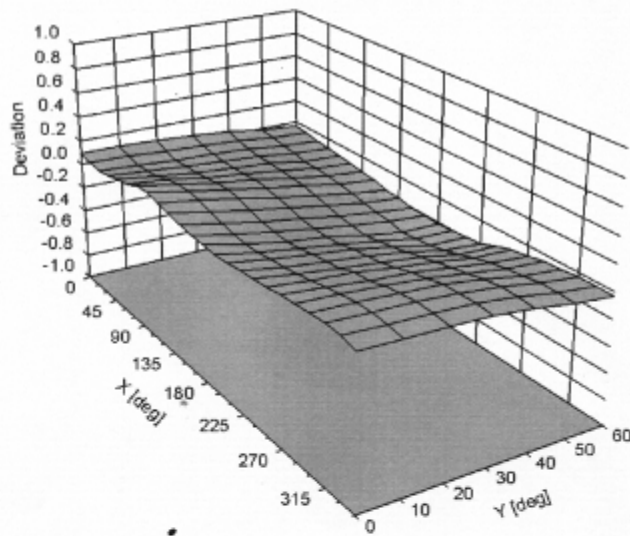

Uncertainty of Spherical Isotropy Assessment: $\pm 2.6\%$ (k=2)

EX3DV4- SN:3816

October 3, 2011

DASY/EASY - Parameters of Probe: EX3DV4 - SN:3816

Other Probe Parameters

Sensor Arrangement	Triangular
Connector Angle (°)	Not applicable
Mechanical Surface Detection Mode	enabled
Optical Surface Detection Mode	disabled
Probe Overall Length	337 mm
Probe Body Diameter	10 mm
Tip Length	9 mm
Tip Diameter	2.5 mm
Probe Tip to Sensor X Calibration Point	1 mm
Probe Tip to Sensor Y Calibration Point	1 mm
Probe Tip to Sensor Z Calibration Point	1 mm
Recommended Measurement Distance from Surface	2 mm

TA Technology (Shanghai) Co., Ltd. Test Report

Report No. RZA1203-0315SAR

Page 65 of 100

ANNEX E: D450V3 Dipole Calibration Certificate

**Calibration Laboratory of
Schmid & Partner
Engineering AG**
Zeughausstrasse 43, 8004 Zurich, Switzerland



S Schweizerischer Kalibrierdienst
C Service suisse d'étalonnage
S Servizio svizzero di taratura
S Swiss Calibration Service

Accredited by the Swiss Accreditation Service (SAS)
The Swiss Accreditation Service is one of the signatories to the EA
Multilateral Agreement for the recognition of calibration certificates

Accreditation No.: **SCS 108**

Client **TA (Auden)**

Certificate No: **D450V3-1065_Nov10**

CALIBRATION CERTIFICATE

Object **D450V3 - SN: 1065**

Calibration procedure(s) **QA CAL-15.v5
Calibration Procedure for dipole validation kits below 800 MHz**

Calibration date: **November 09, 2010**

This calibration certificate documents the traceability to national standards, which realize the physical units of measurements (SI).
The measurements and the uncertainties with confidence probability are given on the following pages and are part of the certificate.

All calibrations have been conducted in the closed laboratory facility: environment temperature (22 ± 3)°C and humidity < 70%.

Calibration Equipment used (M&TE critical for calibration)

Primary Standards	ID #	Cal Date (Calibrated by, Certificate No.)	Scheduled Calibration
Power meter E4419B	GB41293874	1-Apr-10 (No. 217-01030)	Apr-11
Power sensor E4412A	MY41495277	1-Apr-10 (No. 217-01030)	Apr-11
Power sensor E4412A	MY41498087	1-Apr-10 (No. 217-01030)	Apr-11
Reference 3 dB Attenuator	SN: S5054 (3c)	31-Mar-10 (No. 217-01026)	Mar-11
Reference 20 dB Attenuator	SN: S5086 (20b)	31-Mar-10 (No. 217-01028)	Mar-11
Type-N mismatch combination	SN: 5047.2 / 06327	31-Mar-10 (No. 217-01029)	Mar-11
Reference Probe ET3DV6 (LF)	SN: 1507	03-Jul-10 (No. ET3-1507_Jul10)	Jul-11
DAE4	SN: 654	04-May-10 (No. DAE4-654_May10)	May-11
Secondary Standards	ID #	Check Date (in house)	Scheduled Check
RF generator HP 8648C	US3642U01700	04-Aug-99 (in house check Oct-10)	In house check: Oct-11
Network Analyzer HP 8753E	US37390585 S4206	18-Oct-01 (in house check Oct-10)	In house check: Oct-11

	Name	Function	Signature
Calibrated by:	Jeton Kastrati	Laboratory Technician	
Approved by:	Katja Pokovic	Technical Manager	

Issued: November 9, 2010

This calibration certificate shall not be reproduced except in full without written approval of the laboratory.

TA Technology (Shanghai) Co., Ltd.

Test Report

Report No. RZA1203-0315SAR

Page 66 of 100

**Calibration Laboratory of
Schmid & Partner
Engineering AG**
Zeughausstrasse 43, 8004 Zurich, Switzerland



S Schweizerischer Kalibrierdienst
C Service suisse d'étalonnage
S Servizio svizzero di taratura
S Swiss Calibration Service

Accredited by the Swiss Accreditation Service (SAS)
The Swiss Accreditation Service is one of the signatories to the EA
Multilateral Agreement for the recognition of calibration certificates

Accreditation No.: **SCS 108**

Glossary:

TSL	tissue simulating liquid
ConF	sensitivity in TSL / NORM x,y,z
N/A	not applicable or not measured

Calibration is Performed According to the Following Standards:

- IEEE Std 1528-2003, "IEEE Recommended Practice for Determining the Peak Spatial-Averaged Specific Absorption Rate (SAR) in the Human Head from Wireless Communications Devices: Measurement Techniques", December 2003
- IEC 62209-1, "Procedure to measure the Specific Absorption Rate (SAR) for hand-held devices used in close proximity to the ear (frequency range of 300 MHz to 3 GHz)", February 2005
- Federal Communications Commission Office of Engineering & Technology (FCC OET), "Evaluating Compliance with FCC Guidelines for Human Exposure to Radiofrequency Electromagnetic Fields; Additional Information for Evaluating Compliance of Mobile and Portable Devices with FCC Limits for Human Exposure to Radiofrequency Emissions", Supplement C (Edition 01-01) to Bulletin 65

Additional Documentation:

- DASY4 System Handbook

Methods Applied and Interpretation of Parameters:

- Measurement Conditions:** Further details are available from the Validation Report at the end of the certificate. All figures stated in the certificate are valid at the frequency indicated.
- Antenna Parameters with TSL:** The dipole is mounted with the spacer to position its feed point exactly below the center marking of the flat phantom section, with the arms oriented parallel to the body axis.
- Feed Point Impedance and Return Loss:** These parameters are measured with the dipole positioned under the liquid filled phantom. The impedance stated is transformed from the measurement at the SMA connector to the feed point. The Return Loss ensures low reflected power. No uncertainty required.
- Electrical Delay:** One-way delay between the SMA connector and the antenna feed point. No uncertainty required.
- SAR measured:** SAR measured at the stated antenna input power.
- SAR normalized:** SAR as measured, normalized to an input power of 1 W at the antenna connector.
- SAR for nominal TSL parameters:** The measured TSL parameters are used to calculate the nominal SAR result.

TA Technology (Shanghai) Co., Ltd.

Test Report

Measurement Conditions

DASY system configuration, as far as not given on page 1.

DASY Version	DASY5	V5.2
Extrapolation	Advanced Extrapolation	
Phantom	ELI4 Flat Phantom	Shell thickness: 2 ± 0.2 mm
Distance Dipole Center - TSL	15 mm	with Spacer
Area Scan Resolution	dx, dy = 15 mm	
Zoom Scan Resolution	dx, dy, dz = 5 mm	
Frequency	450 MHz \pm 1 MHz	

Head TSL parameters

The following parameters and calculations were applied.

	Temperature	Permittivity	Conductivity
Nominal Head TSL parameters	22.0 °C	43.5	-0.87 mho/m
Measured Head TSL parameters	(22.0 \pm 0.2) °C	44.2 \pm 6 %	0.86 mho/m \pm 6 %
Head TSL temperature during test	(22.0 \pm 0.2) °C	---	---

SAR result with Head TSL

SAR averaged over 1 cm³ (1 g) of Head TSL	condition	
SAR measured	398 mW input power	1.87 mW / g
SAR normalized	normalized to 1W	4.70 mW / g
SAR for nominal Head TSL parameters	normalized to 1W	4.76 mW / g \pm 18.1 % (k=2)

SAR averaged over 10 cm³ (10 g) of Head TSL	condition	
SAR measured	398 mW input power	1.25 mW / g
SAR normalized	normalized to 1W	3.14 mW / g
SAR for nominal Head TSL parameters	normalized to 1W	3.17 mW / g \pm 17.6 % (k=2)

TA Technology (Shanghai) Co., Ltd.
Test Report

Body TSL parameters

The following parameters and calculations were applied.

	Temperature	Permittivity	Conductivity
Nominal Body TSL parameters	22.0 °C	56.7	0.94 mho/m
Measured Body TSL parameters	(22.0 ± 0.2) °C	54.1 ± 6 %	0.90 mho/m ± 6 %
Body TSL temperature during test	(22.0 ± 0.2) °C	----	----

SAR result with Body TSL

SAR averaged over 1 cm ³ (1 g) of Body TSL	condition	
SAR measured	398 mW input power	1.77 mW / g
SAR normalized	normalized to 1W	4.37 mW / g
SAR for nominal Body TSL parameters	normalized to 1W	4.51 mW / g ± 18.1 % (k=2)

SAR averaged over 10 cm ³ (10 g) of Body TSL	condition	
SAR measured	398 mW input power	1.18 mW / g
SAR normalized	normalized to 1W	2.94 mW / g
SAR for nominal Body TSL parameters	normalized to 1W	3.03 mW / g ± 17.6 % (k=2)

TA Technology (Shanghai) Co., Ltd.

Test Report

Appendix

Antenna Parameters with Head TSL

Impedance, transformed to feed point	59.2 Ω - 4.9 j Ω
Return Loss	- 20.5 dB

Antenna Parameters with Body TSL

Impedance, transformed to feed point	56.5 Ω - 7.9 j Ω
Return Loss	- 20.4 dB

General Antenna Parameters and Design

Electrical Delay (one direction)	1.354 ns
----------------------------------	----------

After long term use with 100W radiated power, only a slight warming of the dipole near the feedpoint can be measured.

The dipole is made of standard semirigid coaxial cable. The center conductor of the feeding line is directly connected to the second arm of the dipole. The antenna is therefore short-circuited for DC-signals.

No excessive force must be applied to the dipole arms, because they might bend or the soldered connections near the feedpoint may be damaged.

Additional EUT Data

Manufactured by	SPEAG
Manufactured on	July 16, 2010

DASY5 Validation Report for Head TSL

Date/Time: 09.11.2010 10:36:58

Test Laboratory: The name of your organization

DUT: Dipole 450 MHz; Type: D450V3; Serial: D450V3 - SN:1065

Communication System: CW; Frequency: 450 MHz; Duty Cycle: 1:1

Medium: HSL450

Medium parameters used: $f = 450 \text{ MHz}$; $\sigma = 0.86 \text{ mho/m}$; $\epsilon_r = 44.2$; $\rho = 1000 \text{ kg/m}^3$

Phantom section: Flat Section

Measurement Standard: DASY5 (IEEE/IEC/ANSI C63.19-2007)

DASY5 Configuration:

- Probe: ET3DV6 - SN1507 (LF); ConvF(6.66, 6.66, 6.66); Calibrated: 03.07.2010
- Sensor-Surface: 4mm (Mechanical Surface Detection)
- Electronics: DAE4 Sn654; Calibrated: 04.05.2010
- Phantom: ELI 4.0; Type: QDOVA001BA; Serial: 1003
- Measurement SW: DASY5, V5.2 Build 157; SEMCAD X Version 14.0 Build 57

Pin=398mW /d=15mm /Area Scan (41x111x1): Measurement grid: dx=15mm, dy=15mm
Maximum value of SAR (interpolated) = 1.99 mW/g

Pin=398mW /d=15mm /Zoom Scan (7x7x7)/Cube 0: Measurement grid: dx=5mm, dy=5mm, dz=5mm

Reference Value = 50.3 V/m; Power Drift = -0.00664 dB

Peak SAR (extrapolated) = 2.81 W/kg

SAR(1 g) = 1.87 mW/g; SAR(10 g) = 1.25 mW/g

Maximum value of SAR (measured) = 2.01 mW/g

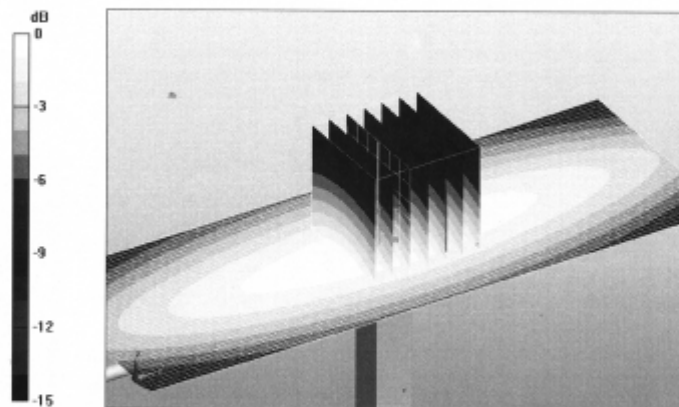

0 dB = 2.01mW/g

Impedance Measurement Plot for Head TSL

9 Nov 2010 10:19:27
[CH1] S11 1 U FS 1: 59.156 Ω -4.8770 Ω 72.520 pF 450.000 000 MHz

*
De1
Cor
Avg
16

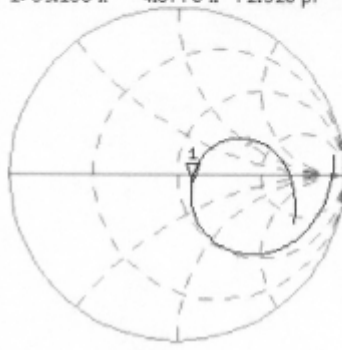

CH2 S11 LOG 5 dB/REF -20 dB 1: -20.446 dB 450.000 000 MHz

Cor
Avg
16

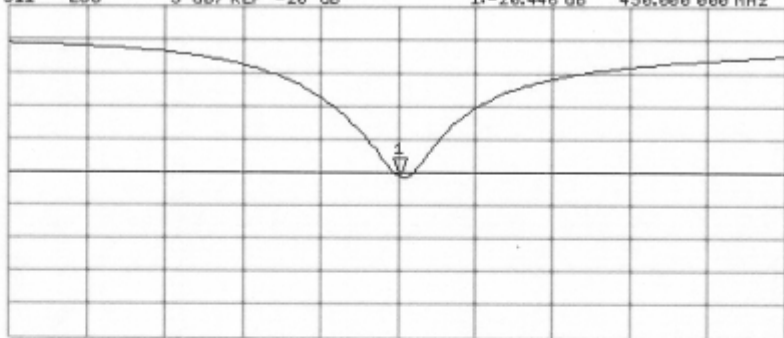

START 250.000 000 MHz STOP 650.000 000 MHz

DASY5 Validation Report for Body TSL

Date/Time: 09.11.2010 13:52:55

Test Laboratory: The name of your organization

DUT: Dipole 450 MHz; Type: D450V3; Serial: D450V3 - SN:1065

Communication System: CW; Frequency: 450 MHz; Duty Cycle: 1:1

Medium: MSL450

Medium parameters used: $f = 450$ MHz; $\sigma = 0.9$ mho/m; $\epsilon_r = 54.1$; $\rho = 1000$ kg/m³

Phantom section: Flat Section

Measurement Standard: DASY5 (IEEE/IEC/ANSI C63.19-2007)

DASY5 Configuration:

- Probe: ET3DV6 - SN1507 (LF); ConvF(7.11, 7.11, 7.11); Calibrated: 03.07.2010
- Sensor-Surface: 4mm (Mechanical Surface Detection)
- Electronics: DAE4 Sn654; Calibrated: 04.05.2010
- Phantom: ELI 4.0; Type: QDOVA001BA; Serial: 1003
- Measurement SW: DASY5, V5.2 Build 157; SEMCAD X Version 14.0 Build 57

Pin=398mW /d=15mm /Area Scan (61x201x1): Measurement grid: dx=10mm, dy=10mm
Maximum value of SAR (interpolated) = 1.89 mW/g

Pin=398mW /d=15mm, /Zoom Scan (7x7x7)/Cube 0: Measurement grid: dx=5mm, dy=5mm, dz=5mm

Reference Value = 47.4 V/m; Power Drift = -0.016 dB

Peak SAR (extrapolated) = 2.7 W/kg

SAR(1 g) = 1.77 mW/g; SAR(10 g) = 1.18 mW/g

Maximum value of SAR (measured) = 1.89 mW/g

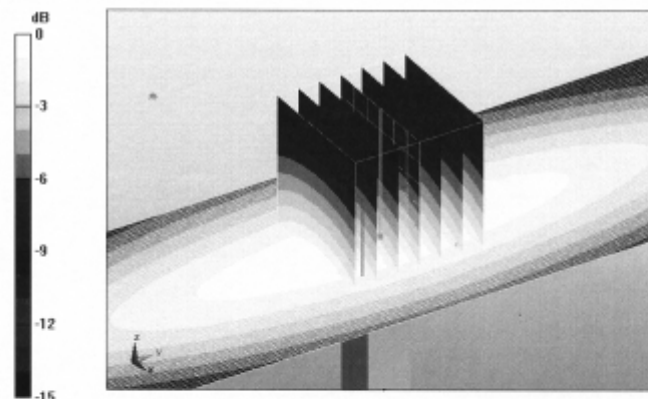

0 dB = 1.89mW/g

TA Technology (Shanghai) Co., Ltd.
Test Report

Impedance Measurement Plot for Body TSL

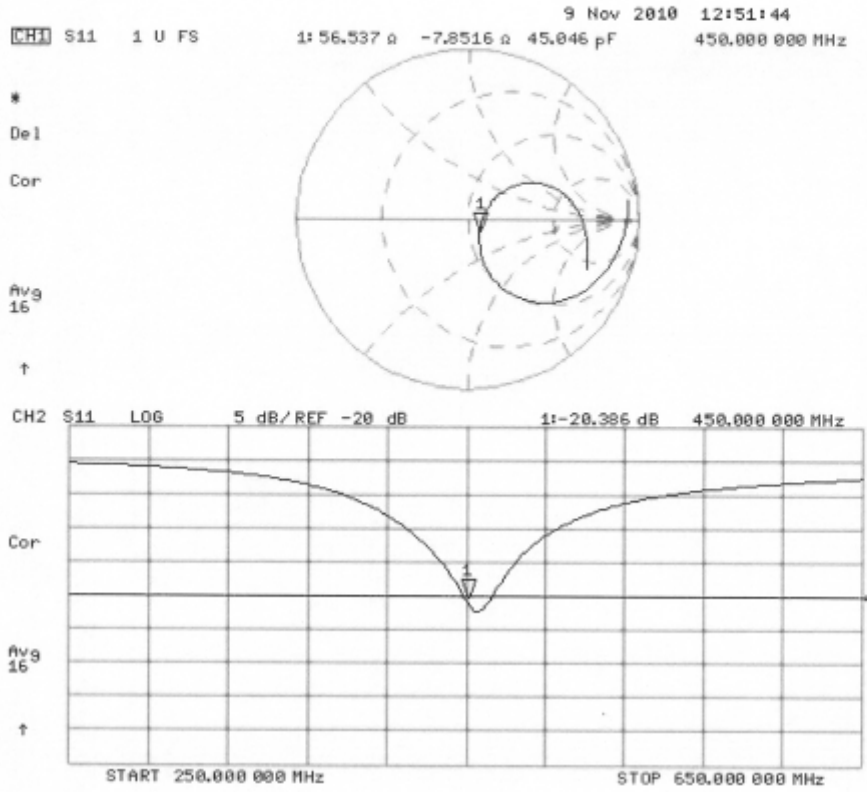

TA Technology (Shanghai) Co., Ltd.

Test Report

Report No. RZA1203-0315SAR

Page 74 of 100

ANNEX F: DAE4 Calibration Certificate

**Calibration Laboratory of
Schmid & Partner
Engineering AG**
Zeughausstrasse 43, 8004 Zurich, Switzerland



S Schweizerischer Kalibrierdienst
C Service suisse d'étalonnage
S Servizio svizzero di taratura
S Swiss Calibration Service

Accredited by the Swiss Accreditation Service (SAS)
The Swiss Accreditation Service is one of the signatories to the EA
Multilateral Agreement for the recognition of calibration certificates

Accreditation No.: **SCS 108**

Client **TA-SH (Auden)**

Certificate No: **DAE4-871_Nov11**

CALIBRATION CERTIFICATE																			
Object	DAE4 - SD 000 D04 BJ - SN: 871																		
Calibration procedure(s)	QA CAL-06.v23 Calibration procedure for the data acquisition electronics (DAE)																		
Calibration date:	November 22, 2011																		
<p>This calibration certificate documents the traceability to national standards, which realize the physical units of measurements (SI). The measurements and the uncertainties with confidence probability are given on the following pages and are part of the certificate.</p> <p>All calibrations have been conducted in the closed laboratory facility; environment temperature (22 ± 3)°C and humidity < 70%.</p> <p>Calibration Equipment used (M&TE critical for calibration)</p> <table border="1" style="width: 100%; border-collapse: collapse;"> <thead> <tr> <th style="width: 30%;">Primary Standards</th> <th style="width: 15%;">ID #</th> <th style="width: 30%;">Cal Date (Certificate No.)</th> <th style="width: 25%;">Scheduled Calibration</th> </tr> </thead> <tbody> <tr> <td>Keithley Multimeter Type 2001</td> <td>SN: 0810278</td> <td>28-Sep-11 (No:11450)</td> <td>Sep-12</td> </tr> <tr> <th>Secondary Standards</th> <th>ID #</th> <th>Check Date (in house)</th> <th>Scheduled Check</th> </tr> <tr> <td>Calibrator Box V1.1</td> <td>SE UMS 006 AB 1004</td> <td>08-Jun-11 (in house check)</td> <td>In house check: Jun-12</td> </tr> </tbody> </table>				Primary Standards	ID #	Cal Date (Certificate No.)	Scheduled Calibration	Keithley Multimeter Type 2001	SN: 0810278	28-Sep-11 (No:11450)	Sep-12	Secondary Standards	ID #	Check Date (in house)	Scheduled Check	Calibrator Box V1.1	SE UMS 006 AB 1004	08-Jun-11 (in house check)	In house check: Jun-12
Primary Standards	ID #	Cal Date (Certificate No.)	Scheduled Calibration																
Keithley Multimeter Type 2001	SN: 0810278	28-Sep-11 (No:11450)	Sep-12																
Secondary Standards	ID #	Check Date (in house)	Scheduled Check																
Calibrator Box V1.1	SE UMS 006 AB 1004	08-Jun-11 (in house check)	In house check: Jun-12																
Calibrated by:	Name Andrea Gunti	Function Technician	Signature 																
Approved by:	Fin Bornholt	R&D Director																	
			Issued: November 22, 2011																
This calibration certificate shall not be reproduced except in full without written approval of the laboratory.																			

**Calibration Laboratory of
Schmid & Partner
Engineering AG**
Zeughausstrasse 43, 8004 Zurich, Switzerland



S Schweizerischer Kalibrierdienst
C Service suisse d'étalonnage
S Servizio svizzero di taratura
S Swiss Calibration Service

Accredited by the Swiss Accreditation Service (SAS)
The Swiss Accreditation Service is one of the signatories to the EA
Multilateral Agreement for the recognition of calibration certificates

Accreditation No.: **SCS 108**

Glossary

DAE data acquisition electronics
Connector angle information used in DASY system to align probe sensor X to the robot coordinate system.

Methods Applied and Interpretation of Parameters

- **DC Voltage Measurement:** Calibration Factor assessed for use in DASY system by comparison with a calibrated instrument traceable to national standards. The figure given corresponds to the full scale range of the voltmeter in the respective range.
- **Connector angle:** The angle of the connector is assessed measuring the angle mechanically by a tool inserted. Uncertainty is not required.
- The following parameters as documented in the Appendix contain technical information as a result from the performance test and require no uncertainty.
 - **DC Voltage Measurement Linearity:** Verification of the Linearity at +10% and -10% of the nominal calibration voltage. Influence of offset voltage is included in this measurement.
 - **Common mode sensitivity:** Influence of a positive or negative common mode voltage on the differential measurement.
 - **Channel separation:** Influence of a voltage on the neighbor channels not subject to an input voltage.
 - **AD Converter Values with inputs shorted:** Values on the internal AD converter corresponding to zero input voltage
 - **Input Offset Measurement:** Output voltage and statistical results over a large number of zero voltage measurements.
 - **Input Offset Current:** Typical value for information; Maximum channel input offset current, not considering the input resistance.
 - **Input resistance:** Typical value for information: DAE input resistance at the connector, during internal auto-zeroing and during measurement.
 - **Low Battery Alarm Voltage:** Typical value for information. Below this voltage, a battery alarm signal is generated.
 - **Power consumption:** Typical value for information. Supply currents in various operating modes.

TA Technology (Shanghai) Co., Ltd.

Test Report

Report No. RZA1203-0315SAR

Page 76 of 100

DC Voltage Measurement

A/D - Converter Resolution nominal

High Range: 1LSB = 6.1 μ V, full range = -100...+300 mV

Low Range: 1LSB = 61nV, full range = -1.....+3mV

DASY measurement parameters: Auto Zero Time: 3 sec; Measuring time: 3 sec

Calibration Factors	X	Y	Z
High Range	404.749 \pm 0.1% (k=2)	404.733 \pm 0.1% (k=2)	405.174 \pm 0.1% (k=2)
Low Range	3.98175 \pm 0.7% (k=2)	3.93601 \pm 0.7% (k=2)	3.96830 \pm 0.7% (k=2)

Connector Angle

Connector Angle to be used in DASY system	90.0 \pm 1 $^{\circ}$
---	-------------------------

TA Technology (Shanghai) Co., Ltd.

Test Report

Appendix

1. DC Voltage Linearity

High Range	Reading (μV)	Difference (μV)	Error (%)
Channel X + Input	199991.9	-0.91	-0.00
Channel X + Input	20000.28	0.48	0.00
Channel X - Input	-19998.51	0.59	-0.00
Channel Y + Input	200003.0	1.24	0.00
Channel Y + Input	19999.67	0.17	0.00
Channel Y - Input	-20000.04	-0.34	0.00
Channel Z + Input	200010.1	-0.11	-0.00
Channel Z + Input	19999.33	-0.07	-0.00
Channel Z - Input	-20001.45	-0.85	0.00

Low Range	Reading (μV)	Difference (μV)	Error (%)
Channel X + Input	2000.0	0.05	0.00
Channel X + Input	199.81	-0.09	-0.04
Channel X - Input	-199.63	0.37	-0.19
Channel Y + Input	1999.9	-0.22	-0.01
Channel Y + Input	198.81	-1.19	-0.59
Channel Y - Input	-201.62	-1.72	0.86
Channel Z + Input	2000.4	0.48	0.02
Channel Z + Input	199.30	-0.70	-0.35
Channel Z - Input	-200.86	-1.06	0.53

2. Common mode sensitivity

DASY measurement parameters: Auto Zero Time: 3 sec; Measuring time: 3 sec

	Common mode Input Voltage (mV)	High Range Average Reading (μV)	Low Range Average Reading (μV)
Channel X	200	14.43	13.13
	-200	-12.22	-13.72
Channel Y	200	-10.07	-9.78
	-200	9.61	8.66
Channel Z	200	-0.56	-0.83
	-200	-0.01	0.11

3. Channel separation

DASY measurement parameters: Auto Zero Time: 3 sec; Measuring time: 3 sec

	Input Voltage (mV)	Channel X (μV)	Channel Y (μV)	Channel Z (μV)
Channel X	200	-	3.08	0.09
Channel Y	200	3.19	-	4.59
Channel Z	200	0.90	-0.06	-

TA Technology (Shanghai) Co., Ltd.

Test Report

4. AD-Converter Values with inputs shorted

DASY measurement parameters: Auto Zero Time: 3 sec; Measuring time: 3 sec

	High Range (LSB)	Low Range (LSB)
Channel X	15920	15519
Channel Y	16179	17567
Channel Z	15791	15270

5. Input Offset Measurement

DASY measurement parameters: Auto Zero Time: 3 sec; Measuring time: 3 sec

Input 10M Ω

	Average (μ V)	min. Offset (μ V)	max. Offset (μ V)	Std. Deviation (μ V)
Channel X	0.03	-1.16	2.66	0.46
Channel Y	-0.63	-3.22	0.29	0.46
Channel Z	-0.87	-2.03	0.28	0.46

6. Input Offset Current

Nominal Input circuitry offset current on all channels: <25fA

7. Input Resistance (Typical values for information)

	Zeroing (kOhm)	Measuring (MOhm)
Channel X	200	200
Channel Y	200	200
Channel Z	200	200

8. Low Battery Alarm Voltage (Typical values for information)

Typical values	Alarm Level (VDC)
Supply (+ Vcc)	+7.9
Supply (- Vcc)	-7.6

9. Power Consumption (Typical values for information)

Typical values	Switched off (mA)	Stand by (mA)	Transmitting (mA)
Supply (+ Vcc)	+0.01	+6	+14
Supply (- Vcc)	-0.01	-8	-9

ANNEX G: The EUT Appearances and Test Configuration



Picture 3-1: EUT

TA Technology (Shanghai) Co., Ltd.
Test Report



Picture 3-2: Thicker Battery

TA Technology (Shanghai) Co., Ltd.
Test Report



Picture 3-3: Thinner Battery



Picture 3-4: Belt



Picture 3-5: Earphone 1



Picture 3-6: Earphone 2

TA Technology (Shanghai) Co., Ltd.
Test Report

Report No. RZA1203-0315SAR

Page 85 of 100



Picture 3-7: Pocket and Leather



Picture 3-8: Accessory 1

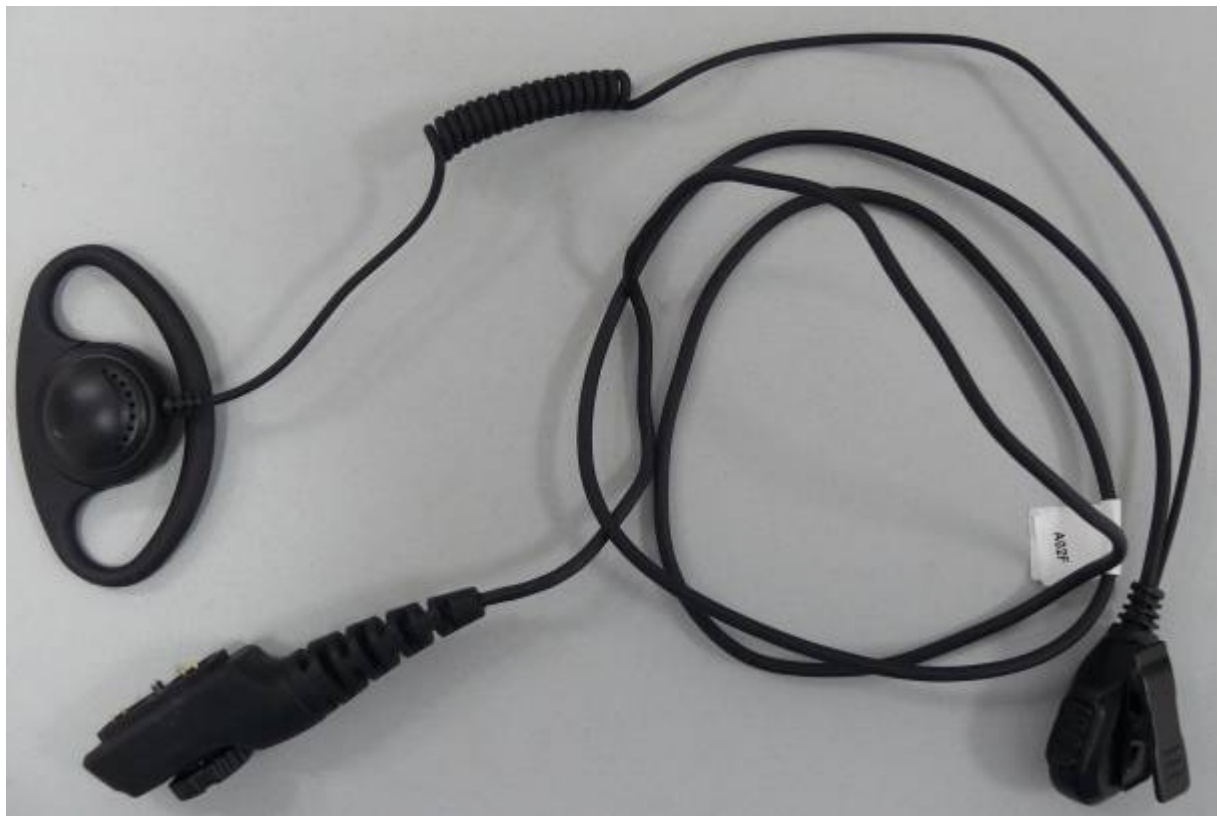

Picture 3-9: Audio Accessory 2



Picture 3-10: Audio Accessory 3



Picture 3-11: Audio Accessory 4



Picture 3-12: Audio Accessory 5

Picture 3: Constituents of the sample

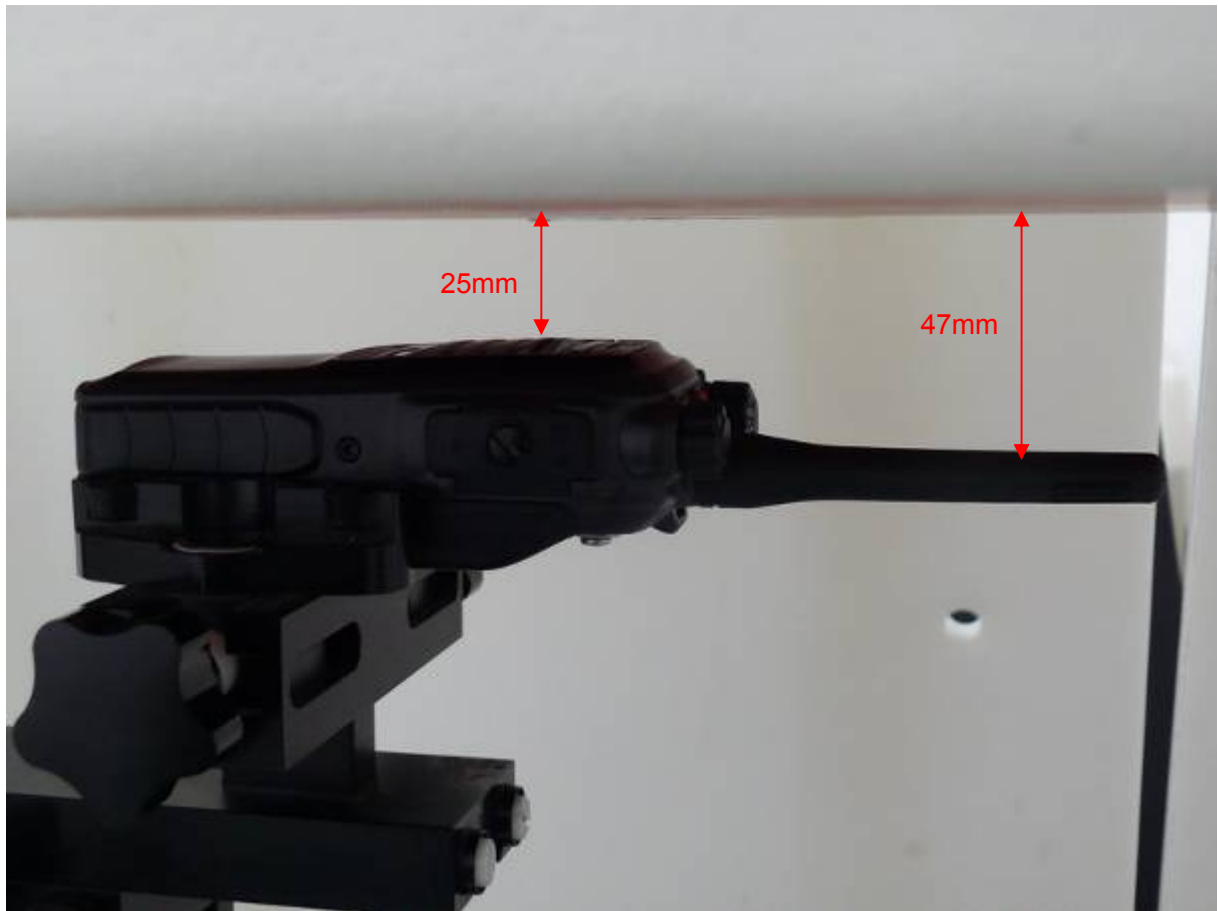

Picture 4: Face-held with Thicker Battery, the front of the EUT towards phantom, the distance from EUT Antenna to the bottom of the Phantom is 47mm

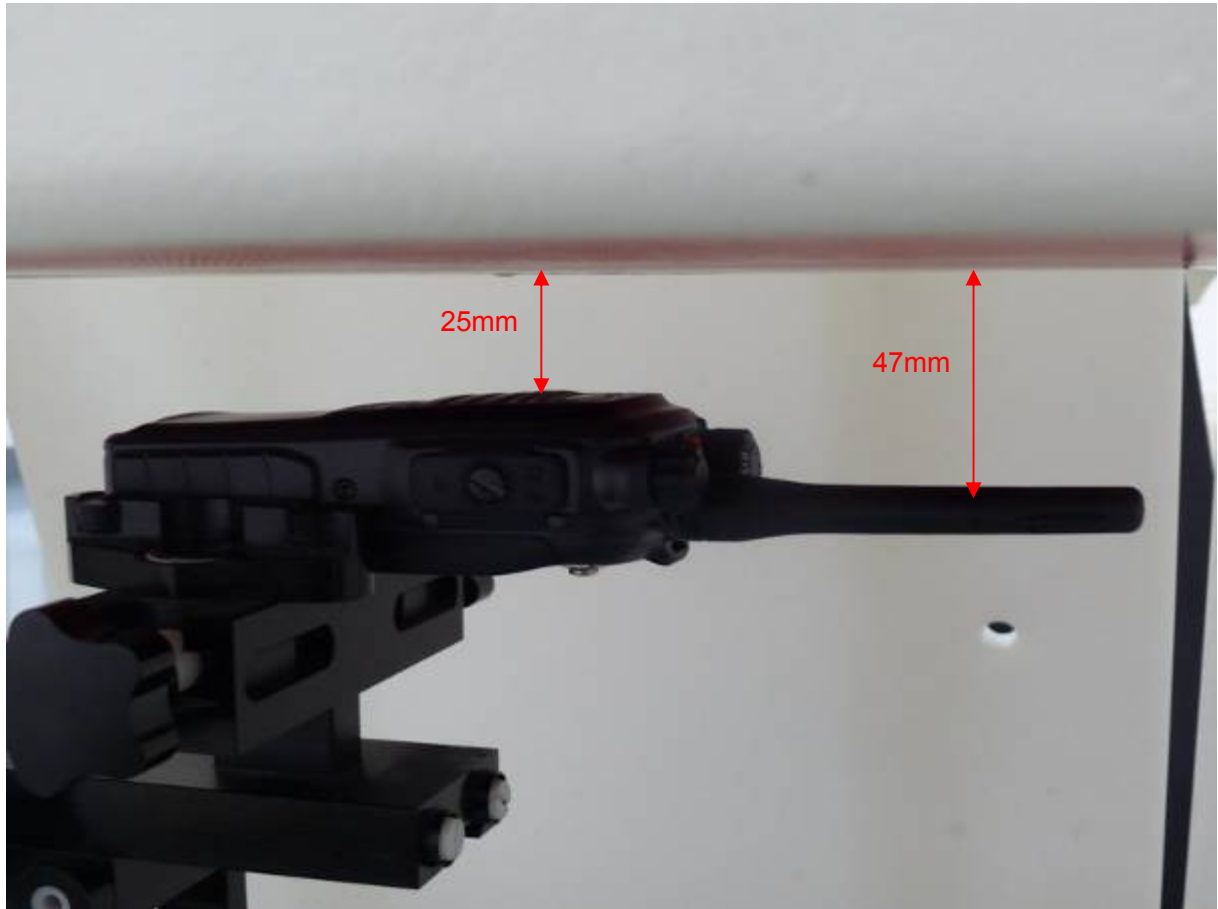

Picture 5: Face-held with Thinner Battery, the front of the EUT towards phantom, the distance from EUT Antenna to the bottom of the Phantom is 47mm



Picture 6: Body-worn with Thinner Battery, Belt and Accessory 1, the front of the EUT towards ground, the distance from EUT Antenna to the bottom of the Phantom is 26mm



Picture 7: Body-worn with Thinner Battery, Belt, Accessory 1 and Earphone 1, the front of the EUT towards ground, the distance from EUT Antenna to the bottom of the Phantom is 26mm



Picture 8: Body-worn with Thinner Battery, Belt, Accessory 1 and Earphone 2, the front of the EUT towards ground, the distance from EUT Antenna to the bottom of the Phantom is 26mm



Picture 9: Body-worn with Thinner Battery, Belt and Audio Accessory 2, the front of the EUT towards ground, the distance from EUT Antenna to the bottom of the Phantom is 26mm



Picture 10: Body-worn with Thinner Battery, Belt and Audio Accessory 3, the front of the EUT towards ground, the distance from EUT Antenna to the bottom of the Phantom is 26mm



Picture 11: Body-worn with Thinner Battery, Belt and Audio Accessory 4, the front of the EUT towards ground, the distance from EUT Antenna to the bottom of the Phantom is 26mm



Picture 12: Body-worn with Thinner Battery, Belt and Audio Accessory 5, the front of the EUT towards ground, the distance from EUT Antenna to the bottom of the Phantom is 26mm



Picture 13: Body-worn with Thinner Battery, Pocket and Accessory 1, the front of the EUT towards ground, the distance from EUT Antenna to the bottom of the Phantom is 26mm



Picture 14: Body-worn with Thinner Battery, Pocket, Leather and Accessory 1, the front of the EUT towards ground, the distance from EUT Antenna to the bottom of the Phantom is 37mm



Picture 15: Body-worn with Thicker Battery, Belt and Audio Accessory 2, the front of the EUT towards ground, the distance from EUT Antenna to the bottom of the Phantom is 24mm