

Preface

Thanks for your favor in our product. This manual is helpful for you to quickly know how to use the product. For detailed features and operations, please refer to the Feature Book along with the product.

This manual is applicable to the following product:
PD682 Um Digital Portable Radio

DIGITAL PORTABLE RADIO



Instructional Icons

 Indicates functions that are available on digital channel only.

 Indicates functions that are available on analog channel only.

Functions marked with no function icons are available on both analog and digital channels.

Disclaimer

Hytera Communications Corporation Limited (the Company) endeavors to achieve the accuracy and completeness of this manual, but no warranty of accuracy or reliability is given. All the specifications and designs are subject to change without notice due to continuous technology development. No part of this manual may be copied, modified, translated, or distributed in any manner without the express written permission of us.

We do not guarantee, for any particular purpose, the accuracy, validity, timeliness, legitimacy or completeness of the Third Party products and contents involved in this manual.

If you have any suggestions or would like to learn more details, please visit our website at:<http://www.hytera.com>.

RF Radiation Information

This product must be restricted to operations in an Occupational/Controlled RF exposure Environments. Users must be fully aware of the hazards of the exposure and able to exercise control over their RF exposure to qualify for the higher exposure limits.

RF Radiation Profile

Radio Frequency (RF) is a frequency of electromagnetic radiation in the range at which radio signals are transmitted. RF technology is widely used in communication, medicine, food processing and other fields. It may generate radiation during use.

RF Radiation Safety

In order to ensure user health, experts from relevant industries including science, engineering, medicine and health work with international organizations to develop standards for safe exposure to RF radiation. These standards consist of:

RF Radiation Information

RF Radiation Profile

Radio Frequency (RF) is a frequency of electromagnetic radiation in the range at which radio signals are transmitted. RF technology is widely used in communication, medicine, food processing and other fields. It may generate radiation during use.

RF Radiation Safety

In order to ensure user health, experts from relevant industries including science, engineering, medicine and health work with international organizations to develop standards for safe exposure to RF radiation. These standards consist of:

- United States Federal Communications Commission, Code of Federal Regulations; 47CFR part 2 sub-part J;
- American National Standards Institute (ANSI)/Institute of Electrical and Electronic Engineers (IEEE) C95. 1-1992;
- Institute of Electrical and Electronic Engineers (IEEE) C95. 1 – 1999;
- International Commission on Non-Ionizing Radiation Protection (ICNIRP) 1998;

Operational Instructions and Training Guidelines

To ensure optimal performance and compliance with the occupational/controlled environment RF energy exposure limits in the above standards and guidelines, users should transmit no more than 50% of the time and always adhere to the following procedures:

Your radio radiates measurable RF energy only while it is transmitting (during talking), not when it is receiving (listening) or in standby mode.

FCC Regulations

Federal Communication Commission (FCC) requires that all radio communication products should meet the requirements set forth in the above standards before they can be marketed in the U.S, and the manufacturer shall post a RF label on the product to inform users of operational instructions, so as to enhance their occupational health against exposure to RF energy.

FCC Statement

This equipment has been tested and found to comply with the limits for a Class B digital device, pursuant to part 15 of FCC Rules. These limits are designed to provide reasonable protection against harmful interference in a residential installation. This equipment generates and can radiate radio frequency energy and, if not installed and used in accordance with the instructions, may cause harmful interference to radio communications. However, there is no guarantee that interference will not occur in a particular installation. If this equipment does cause harmful interference to radio or television reception, which can be determined by turning the equipment off and on, the user is encouraged to try to correct.

The interference by one or more of the following measures:

- Reorient or relocate the receiving antenna. Increase the separation between the equipment and receiver.
- Connect the equipment into an outlet on a circuit different from that to which the receiver is connected.
- Consult the dealer or an experienced radio/TV technician for help

Operation is subject to the following two conditions: 1. This device may not cause harmful interference, and 2. This device must accept any interference received, including interference that may cause undesired operation.

Note:” Changes or modifications to this unit not expressly approved by the party responsible for compliance could void the user’s authority to operate the equipment.”

Compliance with RF Exposure Standards

Hytera’s 2-way radio complies with the following RF energy exposure standards and guidelines:

- United States Federal Communications Commission, Code of Federal Regulations; 47 CFR §§ 1.1307, 1.1310 and 2.1093
- American National Standards Institute (ANSI) / Institute of Electrical and Electronic Engineers (IEEE) C95. 1-1992
- Institute of Electrical and Electronic Engineers (IEEE) C95.1-1999 Edition

RF Exposure Compliance and Control Guidelines and

Operating Instructions

To control your exposure and ensure compliance with the occupational/controlled environment exposure limits always adhere to the following procedures.

Guidelines:

- Do not remove the RF Exposure Label from the device.
- User awareness instructions should accompany device when transferred to other users.
- Do not use this device if the operational requirements described herein are not met.

Operating Instructions:

- Transmit no more than the rated duty factor of 50% of the time. To transmit (talk), push the Push-To-Talk (PTT) button. To receive calls, release the PTT button. Transmitting 50 % of the time, or less, is important because this radio generates measurable RF energy exposure only when transmitting (in terms of measuring for standards compliance).
- Hold the radio in a vertical position in front of face with the microphone (and the other parts of the radio, including the antenna) at least one inch (2.5 cm) away from the nose. Keeping the radio at the proper distance is important because RF exposures decrease with distance from the antenna. Antenna should be kept away from eyes.
- When worn on the body, always place the radio in a Hytera's approved clip, holder, holster, case, or body harness for this product. Using approved body-worn accessories is important because the use of Hytera's or other manufacturer's non-approved accessories may result in exposure levels, which exceed the FCC's occupational/controlled environment RF exposure limits.
- If you are not using a body-worn accessory and are not using the radio in the intended use position in front of the face, then ensure the antenna and the radio are kept at least 2.5 cm (one inch) from the body when transmitting. Keeping the radio at the proper distance is important because RF exposures decrease with increasing distance from the antenna.
- Use only manufacturer's name approved supplied or replacement antennas, batteries, and accessories. Use of non-manufacturer-name approved antennas, batteries, and accessories may exceed the FCC RF exposure guidelines.
- For a list of Hytera's approved accessories (see the user manual), or (visit the following website which lists approved accessories: [http: add website address](http://add website address)), or (The manufacturer should include the appropriate bracketed item{s} in the manual.)
- For a list of Hytera's approved accessories (see the user manual), or (visit the following website which lists approved accessories: www.hytera.cn)

IC statement

The device has been tested and compliance with SAR limits, users can obtain Canadian information on RF exposure and compliance

Après examen de ce matériel aux conformité aux limites DAS et/ou aux limites d'intensité de champ RF, les utilisateurs peuvent sur l'exposition aux radiofréquences et la conformité and compliance d'acquérir les informations correspondantes

EU Regulatory Conformance

As certified by the qualified laboratory, the product is in compliance with the essential requirements and other relevant provisions of the Directive 1999/5/EC. Please note t



- United States Federal Communications Commission, Code of Federal Regulations; 47CFR part 2 sub-part J;
- American National Standards Institute (ANSI)/Institute of Electrical and Electronic Engineers (IEEE) C95. 1-1992;
- Institute of Electrical and Electronic Engineers (IEEE) C95.1-1999;
- International Commission on Non-Ionizing Radiation Protection (ICNIRP) 1998.

FCC Regulations

Federal Communication Commission (FCC) requires that all radio communication products should meet the requirements set forth in the above standards before they can be marketed in the U.S, and the manufacturer shall post a RF label on the product to inform users of operational instructions, so as to enhance their occupational health against exposure to RF energy.

Operational Instructions and Training Guidelines

To ensure optimal performance and compliance with the occupational/controlled environment RF energy exposure limits in the above standards and guidelines, users should transmit not more than 50% of the time and always adhere to the following procedures:





- RF energy will be generated only when the radio is transmitting.
- The radio must be 2.5 centimeters away from human body when transmitting.

EU Regulatory Conformance

As certified by the qualified laboratory, the product is in compliance with the essential requirements and other relevant provisions of the Directive 1999/5/EC.

Please note that the above information is applicable to EU countries only.

Contents

Items in the Package -----	1	Adjusting the Volume	8
Product Overview -----	2	Selecting a Zone	8
Product Controls	2	Selecting a Channel	8
Programmable Keys	3	Inputting via Keypad	9
Before Use -----	3	Locking and Unlocking the Keypad	9
Assembling the Radio	3	Managing the Contacts	9
Charging the Battery	4	Call Services -----	10
Checking the Battery Power	5	Private Call 	10
Status Indication -----	5	Group Call 	11
LCD Icon	5	Calling on Analog Channel (No Signaling) 	11
LED Indicator	6	Emergency Alarm	11
Menu Navigation -----	7	Message Service 	12
Basic Operations -----	8	Troubleshooting -----	13
Powering On/Off	8	Care and Cleaning -----	14
		Optional Accessories -----	15

Items in the Package

Please unpack carefully and check that all items listed below are received. If any item is missing or damaged, please contact your dealer.

 **Note** The frequency band is marked on the label of antenna; if not, please refer to the label on the radio for frequency band information.

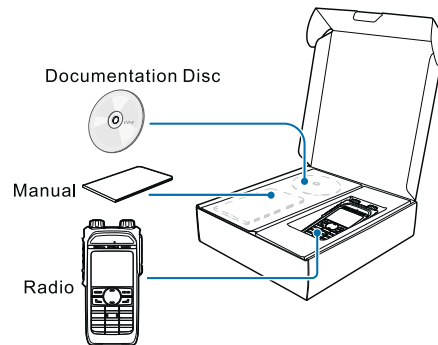

 **Note** All pictures in this manual are for reference only.

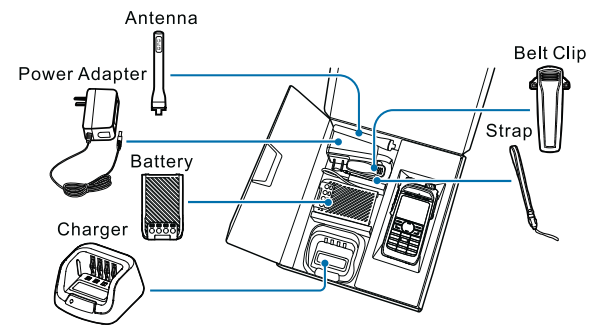

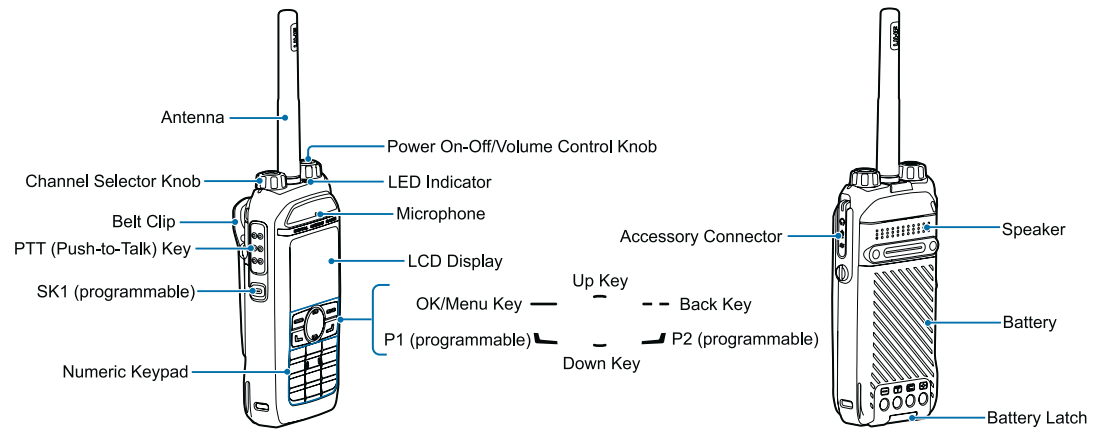

Product Overview

Product Controls



Product Overview

Programmable Keys

For enhanced convenience, you may request your dealer to program the SK1, P1 () and P2 () as shortcuts to certain feature. Please refer to the corresponding Feature Book for feature details.

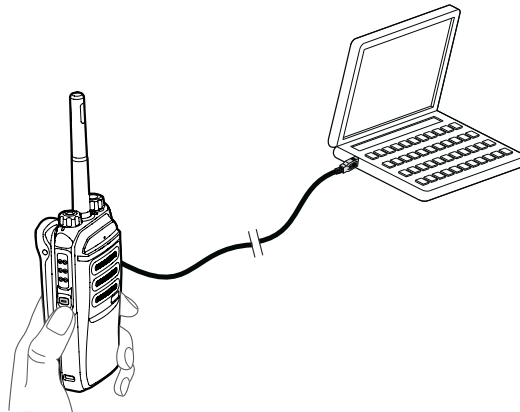

Before Use

Assembling the Radio

1. Assembling the Battery

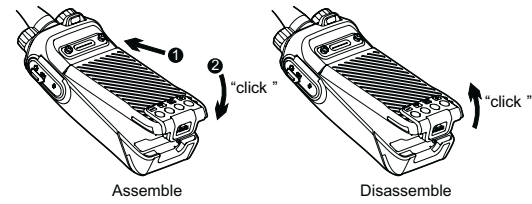

Note

To remove the battery, please turn off the radio first. Then slide the battery latch upwards to unlock the battery.

2. Assembling the Antenna

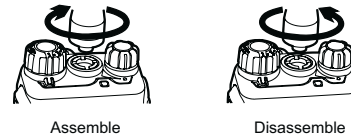

Before Use

Caution  Do not hold the radio by its antenna, otherwise the performance and lifespan of the antenna will be reduced.

3. Assembling the Belt Clip

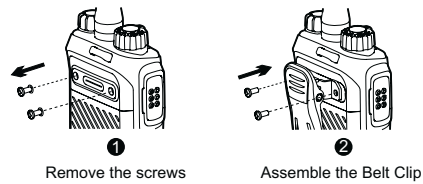

4. Assembling the Accessories

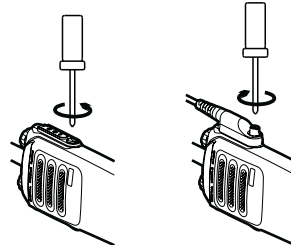





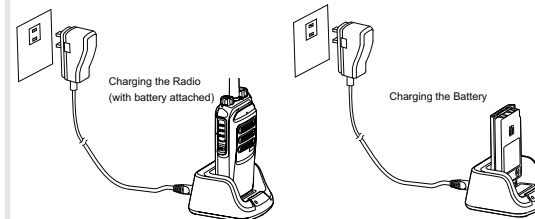

Charging the Battery

Please use the charger specified by the Company, and follow the charging steps as shown below.



Charging Status Indication (on charger):

LED Indication	Current Status
 The LED Indicator flashes red slowly	Standby (no load)
 The LED Indicator glows red	Charging
 The LED Indicator glows orange	90% charged
 The LED Indicator glows green	Fully charged
 The LED Indicator flashes red rapidly	Charging error

- Make sure the radio is powered off before charging.
 - Read the Safety Information Booklet in advance to get necessary safety information.
- Caution**  To achieve optimal battery performance, please charge the battery for at least 5 hours before initial use.

Before Use

Checking the Battery Power

You may check the current battery power by holding down the programmed **Battery Power Indicator** key preset by your dealer. And release the key to exit. Battery power indications are listed below:





















LED Indication	Battery Power
● The LED indicator glows green	High
● The LED indicator glows orange	Medium
● The LED indicator glows red	Low
● The LED indicator glows red and low battery alert beeps	Under the low battery threshold. Please recharge or replace the battery for proper radio operation

Status Indication

LCD Icon







Name	Icon	Radio Status
DTMF Keypad Icon		The DTMF keypad is enabled.
GPS Icon		The GPS feature is enabled, and valid GPS data is received.
Battery Power Icon		The GPS feature is enabled, but no valid GPS data is received.
TX Power Icon		More bars indicate more battery power.
Accessory Icon		Low TX power for the current channel.
Work Order Icon		High TX power for the current channel.
Operation Mode Icon	DM	An accessory is connected.
Monitor Icon		One or more new work orders are received.
Emergency Icon		Direct Mode Operation: Under this mode, the radio communicates with other radios directly.
Roam Icon		Repeater Mode Operation: Under this mode, the radio communicates with other radios via a repeater.
Scrambler/Encrypt Icon		The Monitor feature is enabled.
		The radio is in emergency state (except for silent emergency type) or an emergency call is received.
		The radio is roaming.
		The Scrambler/Encrypt feature is enabled.

Status Indication

Scan Icon		The radio is scanning.
		The radio stays on a non-priority channel.
		The radio stays on Priority Channel 1.
		The radio stays on Priority Channel 2.
VOX Icon		The VOX feature is enabled.
Missed Call Icon		Missed call(s).
Message Icon		Unread message(s).
		Inbox is full.
RSSI Icon		No signal.
		More bars indicate better signal strength.
Speaker Icon		The speaker is unmuted.
LQO Icon		The LQO feature is enabled.
Call/Contact Icon		<ul style="list-style-type: none"> Indicates Private Call during a call.
		<ul style="list-style-type: none"> Indicates Private Contact in the contact list.
		<ul style="list-style-type: none"> Indicates Group Call during a call.
		<ul style="list-style-type: none"> Indicates Group Contact in the contact list.
		<ul style="list-style-type: none"> Indicates All Call during a call.
		<ul style="list-style-type: none"> Indicates All Call Contact in the contact list.

LED Indicator



LED Indication	Product Status
 The LED indicator flashes green	Powering on
 The LED indicator glows green	Receiving
 The LED indicator glows red	Transmitting
 The LED indicator flashes orange slowly	Scanning or Roaming
 The LED indicator flashes orange rapidly	Emergency
 The LED indicator glows orange	Call hung. During a call, you can hold down the PTT key to talk to the other party before the call hang time expires.

Menu Navigation

The following diagram outlines the menu structure of the radio. You can personalize menu option displayed in the radio via your dealer.

To select and confirm the options shown in the menu, press the **Menu** key to enter the main menu, and then press the **Up/Down** key to select the appropriate option, finally press the **OK** key. This manual only describes the paths to the menus in terms of menu operations, for example, to access the contact list, go to "Contact -> Contact List".

The radio supports menu reset function. If you do not operate the menu for a predefined time period set by the dealer, the radio will automatically return to the home screen. You may request your dealer to configure the auto reset time or disable the feature.

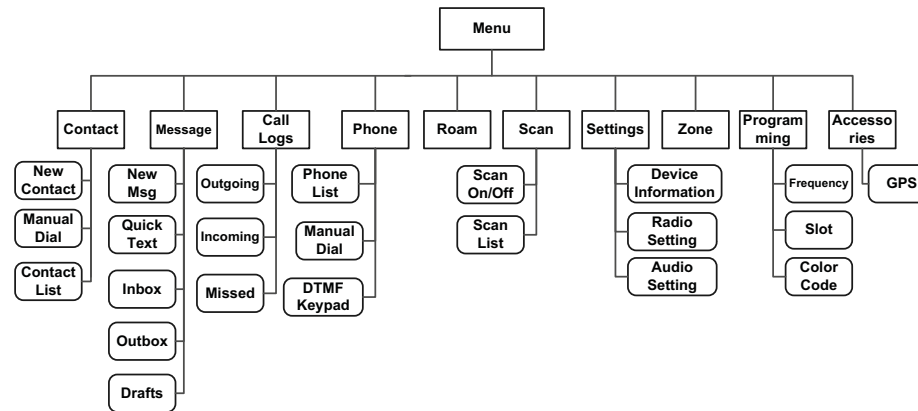

Basic Operations

Powering On/Off

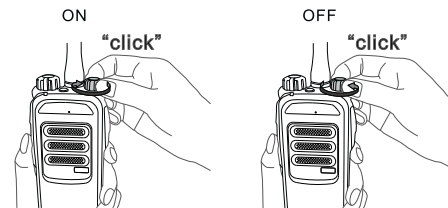

Adjusting the Volume



Selecting a Zone

A zone is a group of channels exhibiting the same property, which is programmed by your dealer and can facilitate convenient management over the channel. The radio supports up to 3 zones, each with a maximum of 16 channels. You can switch to the appropriate zone by pressing the programmed **Zone Up** or **Zone Down** key preset by your dealer.

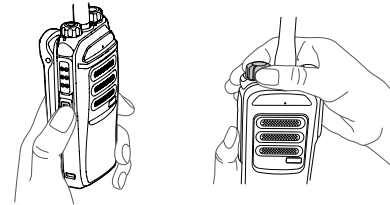

Selecting a Zone

Selecting a Channel

Selecting a Channel



After the radio is powered on, you can rotate the **Channel Selector** knob to select an appropriate channel. You can also switch to the designated channel by pressing the programmed **Preset Channel** key preset by your dealer.

If the Channel Notify feature is enabled, you will hear the corresponding channel number when switching to any channel.

Basic Operations

Inputting via Keypad

You can input alias, call numbers and messages via the keypad of the radio. Besides, you may need to do the following during inputting.

- To switch input method: 
- To input special characters: 
- To input space: 



Locking and Unlocking the Keypad

When the keypad is not in use, you can lock the keypad to avoid mishandling. You can lock or unlock the keypad through any of the following methods:

- Key Combination: Press the **OK** key and then press .
- Programmable Key: Press the programmed **Keypad Lock** key preset by your dealer.
- Menu Navigation: Go to "Settings -> Radio Settings -> Keypad Lock" to enable or disable the feature.
 - » Enable: The keypad will be locked automatically if there is no radio operation within the preset time. After this feature is enabled, you can press the **Up/Down** key to set the Keypad Auto Lock Delay Time.
 - » Disable: The keypad will not be locked automatically. However, you can lock or unlock the keypad via the key combination or **Keypad Lock** key mentioned above.



Note

All keys on the front panel except for P1 () and P2 () will be locked by default. Moreover, you can go to "Settings -> Radio Settings -> Select Button Lock" to configure other lockable keys or knobs

Managing the Contacts

You can manage the contacts via the "Contact" menu.

Contact List

The Contact List is used to save Private Call/Group Call/All Call contacts information such as Call Alias, Call Type and Call ID. You can access the "Contact List" menu via the "Contact" menu or by pressing the programmed **Contact List** key.

In the "Contact List" menu, you can check the contact information, edit or delete the private contact. You can send to a private call contact the following commands: Alert Call, Radio Check, Remote Monitor, Radio Enable or Radio Disable. Please refer to Feature Book for more details.

New Contact

You can add and save a new contact to the contact list. The number and alias of each contact must be unique.



Note

Except for adding a new contact, you can also save the new numbers from Call Logs, ReDial List and BackDial List into the contact list.

Call Services

After the radio is powered on, you can make and receive calls. To ensure optimal volume of the receiving radio, keep the microphone about 2.5 to 5 centimeters away from your mouth when transmitting.

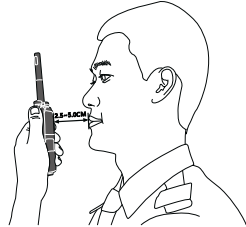

Private Call

Initiating a Private Call

When initiating a private call, the radio will display the icon . You can make a private call through the following ways:

Preset Contact

In the home screen, hold down the **PTT** key to initiate a Private Call to the Private Call contact preset for the current channel.

You may request your dealer to preset a regular Private Call contact, Group Call contact or an All Call contact for each digital channel.

Contact List or Call Logs

1. Go to "Menu -> Contact -> Contact List" or "Menu -> Call Logs -> Outgoing/Incoming/Missed".
2. Use the **Up/Down** key to select an appropriate contact.
3. Hold down the **PTT** key to initiate a Private Call.

Manual Dial

1. Go to "Menu -> Contact -> Manual Dial".
2. Input a Private Call number via the numeric keypad.
3. Hold down the **PTT** key to initiate a Private Call.

- If both the Private Call Manual Dial and Group Call Manual Dial are available, you can press  to switch between the two dialing methods, and the radio will display the call type (private call ID/ group call ID).



Note

- If the Default Numeric Key Selection feature is enabled by your dealer, you can enter a private call number in the home screen, and then press the **PTT** key to transmit the call. However, if the DTMF keypad is enabled, the number entered in the home screen is a phone number. You can dial the private call number through the menu "Manual Dial" only.

Call Services

Receiving and Responding to a Private Call

After receiving a private call, the radio will display the icon , then you can listen without any operation. You can hold down the **PTT** key to call back within the preset time. If you do not respond it, the radio will display appropriate indications.

Group Call

Initiating a Group Call

When initiating a group call, the radio will display the icon . You can make a group call through the following ways. The operation is similar to initiating a private call.

Preset Contact

In the home screen, hold down the **PTT** key to initiate a Group Call to the Group Call contact preset for the current channel.

Contact List

1. Go to "Menu -> Contact -> Contact List".
2. Use the **Up/Down** key to select an appropriate contact.
3. Hold down the **PTT** key to initiate a Group Call.

Manual Dial

The operation is the same as initiating a private call.

Receiving and Responding to a Group Call

After receiving a group call, the radio will display the icon . You can hold down the **PTT** key to call back within the preset time.

Call on Analog Channel (No Signaling)

On an analog channel, you can hold down the **PTT** key and talk to the microphone to transmit, and release the **PTT** key to receive.

Please refer to the corresponding Feature Book for operation description on how to make and receive calls on the analog channel with signaling.

Emergency Call

In case of emergency, you can use this feature to ask for help from your companion or the control center. The Emergency Call has the highest priority which can terminate the ongoing calls with lower priorities on the current channel. You can make an emergency call even when your radio is transmitting or receiving.

This feature needs to be configured and enabled by your dealer. Please refer to the corresponding Feature Book for details.

Message Service

This feature allows you to edit and send a new message, to directly send a quick text message and to forward the messages in the Inbox, Outbox and Drafts.

Sending a message



1. Go to "Menu -> Message -> New Msg" to enter the relevant screen.
2. Type the text and press the **OK** key. Save it to Drafts, or send it to a private call contact or a group call contact.
3. Select the contact or input the contact number manually.
4. Press the **OK** key to send the message. When the message is sent successfully, the radio will display the prompt "Send Success!".

Quick Text

Quick Text are frequently used messages preset by your dealer. You can choose to edit and send any entry.

Inbox



The radio saves the received messages into the Inbox and marks every message with a corresponding icon to indicate its status.

-  : Read message
-  : Unread message

When the Inbox is full, the radio will display the icon , and the earliest message will be overwritten by the latest one automatically.

Outbox

The radio will save the sent messages into the OutBox and marks every message with a corresponding icon to indicate its status.

-  : The message is sent successfully.
-  : The message is not sent successfully. In this case, you can resend it.

When the Outbox is full, the earliest message will be overwritten by the latest one automatically.

Drafts

The radio saves the edited messages into the Drafts. When the Drafts is full, the earliest message will be overwritten by the latest one automatically. After the message in the Drafts is sent successfully, it will be removed from the Drafts and be saved into the Outbox. If not sent successfully, the message will be saved into the Drafts and the Outbox.

Troubleshooting

If the solutions below cannot fix the problems for you, or you may have some other queries, please contact us or your local dealer for more technical support.

Phenomena	Analysis	Solution
Power-on Failure.	The battery may be improperly installed.	Remove the battery and reassemble it.
	The battery power may be used up.	Recharge or replace the battery.
	The battery is poorly connected due to dirtied or damaged battery contacts.	Clean the battery contacts. If the problem cannot be solved, contact your dealer or authorized service center for inspection and repair.
During receiving, the voice is weak, discontinuous or totally inactive.	The battery voltage may be low.	Recharge or replace the battery.
	The volume level may be low.	Increase the volume by rotating the Volume Control knob.
	The antenna may be loosened or improperly installed.	Reassemble the antenna after turning off the radio. Clean the surface of the speaker. If the problem cannot be solved, contact your dealer or authorized service center for inspection and repair.
You cannot communicate with other members.	The speaker may be blocked or damaged.	repair
	The frequency or signaling may be inconsistent with that of other members.	Set your TX/RX frequency and signaling to the same as that of other members.
Irrelevant communication or noise is heard on the channel.	The channel type (digital/analog) may be set inconsistently.	Make sure all members are on the same digital/analog channel.
	You may be too far away from the group members.	Move towards other members.
	You may be interrupted by radios using the same frequency.	Change the frequency, or adjust the squelch level.
The noise is too loud.	The radio may be set with no signaling.	Set signaling for all member radios to avoid interference at the same frequency. And change the signaling settings for all portable radios at the same time.
	You may be too far away from other members.	Move towards other members.
	You may locate in an unfavorable position. For example, your communication may be blocked by high buildings or frustrated in the underground areas. You may suffer from external disturbance (such as electromagnetic interference).	Move to an open and flat area, and restart the radio to try again. Stay away from equipment that may cause interference.

Care and Cleaning

To guarantee optimal performance as well as a long service life of the product, please follow the tips below.

Product Care



Do not pierce or scrape the product.



Keep the product far away from substances that can corrode the circuit.



Do not hold the product by its antenna directly.



Do not hold the product by its earpiece cable directly.



Attach the accessory connector cover when the accessory is not in use.

Product Cleaning



Turn off the product and remove the battery before cleaning.

- Clean up the dust and fine particles on the product surface and charging piece with a clean and dry lint-free cloth or a brush regularly.
- Use neutral cleanser and a non-woven fabric to clean the keys, control knobs and front case after long-time use. Do not use chemical preparations such as stain removers, alcohol, sprays or oil preparations, so as to avoid surface case damage.
- Make sure the product is completely dry before use.

Optional Accessories

The following items are the main optional accessories for the radio. For more information of other accessories, please consult your local dealer.



Caution Use the accessories specified by Hytera only. If not, the Company shall not be liable for any losses or damages arising out of use of unauthorized accessories.



Power Supply: BL2010 2000mAh Li-Ion battery,
MCA08 MCU Multi-unit Charger (for Thick Battery),
CH10A06 Dual Pocket MCU Charger Kit (for Li-ion/Ni-MH Batteries),
PS7501 Switching Power Adapter for MCU Multi-unit Rapid-rate Charger,
MCA05 Battery Optimizing System



Audio: EAN21 3-wire Surveillance Earpiece with Transparent Acoustic Tube(Beige),
ESN14 Remote Earbud,
EHN20 Remote Swivel Earset,
EHN21 Remote C-Earset,
EAN22 Detachable Earpiece with Transparent Acoustic Tube,
SM26N1 Waterproof Remote Speaker Microphone (IP67),

SM26N2 Waterproof Remote Speaker Microphone (IP54),
EAN24 2-wire Surveillance Earpiece with Transparent Acoustic Tube (Beige),
EWN08 Digital Wireless Covert Earpiece (Flatpack Sensor)



Cable: PC45 Programming Cable (USB Port)



Carry Accessories: NCN011 Nylon Carrying Case (half-folded) (non-swivel) (black)