

Test Plot 1#: PTT_FM 12.5kHz_Face Up_136.0125 MHz**DUT: Digital Poratable Radio; Type: PD502i VHF; Serial: 17122000720**

Communication System: FM; Frequency: 136.012 MHz; Duty Cycle: 1:1

Medium parameters used: $f = 136.012$ MHz; $\sigma = 0.768$ S/m; $\epsilon_r = 51.319$; $\rho = 1000$ kg/m³

Phantom section: Flat Section

DASY5 Configuration:

- Probe: EX3DV4 - SN7329; ConvF(12.88, 12.88, 12.88); Calibrated: 2018/1/22;
- Sensor-Surface: 1.4mm (Mechanical Surface Detection)
- Electronics: DAE4 Sn1459; Calibrated: 2017/9/15
- Phantom: ELI v8.0; Type: QDOVA004AA; Serial: 2051
- Measurement SW: DASY52, Version 52.8 (8);

Area Scan (71x151x1): Interpolated grid: dx=1.500 mm, dy=1.500 mm

Maximum value of SAR (interpolated) = 2.64 W/kg

Zoom Scan (5x5x7)/Cube 0: Measurement grid: dx=8mm, dy=8mm, dz=5mm

Reference Value = 43.91 V/m; Power Drift = -0.11 dB

Peak SAR (extrapolated) = 3.74 W/kg

SAR(1 g) = 2.4 W/kg; SAR(10 g) = 1.64 W/kg

Maximum value of SAR (measured) = 2.54 W/kg

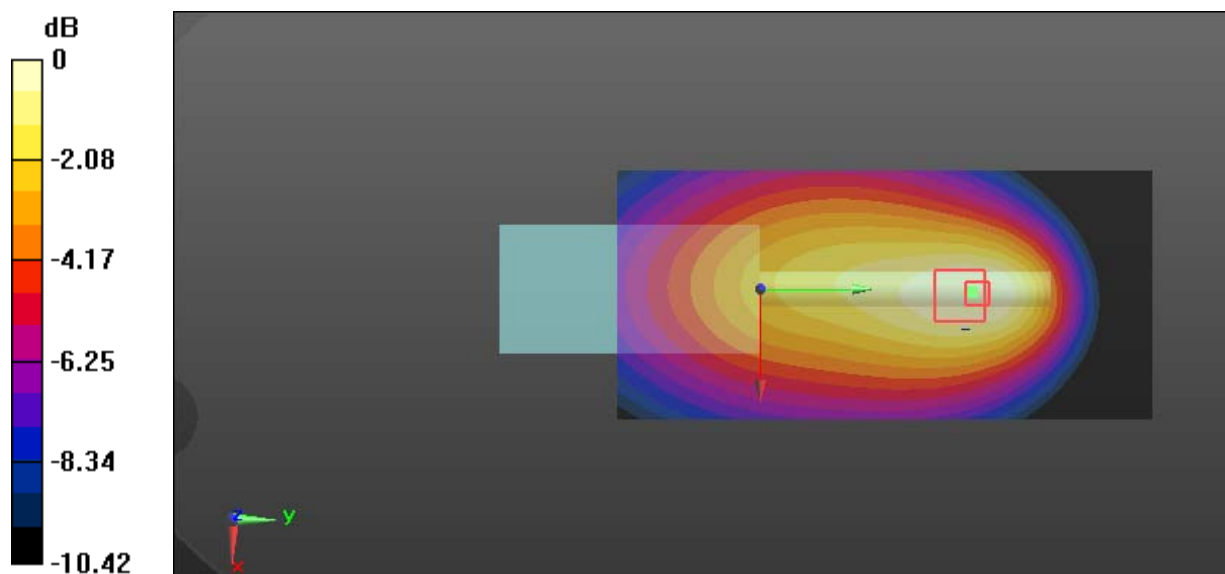

Test Plot 2#: PTT_FM 25kHz_Face Up_136.0125 MHz

DUT: Digital Poratable Radio; Type: PD502i VHF; Serial: 17122000720

Communication System: FM; Frequency: 136.012 MHz;Duty Cycle: 1:1

Medium parameters used: $f = 136.012$ MHz; $\sigma = 0.768$ S/m; $\epsilon_r = 51.319$; $\rho = 1000$ kg/m³

Phantom section: Flat Section

DASY5 Configuration:

- Probe: EX3DV4 - SN7329; ConvF(12.88, 12.88, 12.88); Calibrated: 2018/1/22;
- Sensor-Surface: 1.4mm (Mechanical Surface Detection)
- Electronics: DAE4 Sn1459; Calibrated: 2017/9/15
- Phantom: ELI v8.0; Type: QDOVA004AA; Serial: 2051
- Measurement SW: DASY52, Version 52.8 (8);

Area Scan (71x151x1): Interpolated grid: dx=1.500 mm, dy=1.500 mm

Maximum value of SAR (interpolated) = 2.73 W/kg

Zoom Scan (5x6x7)/Cube 0: Measurement grid: dx=8mm, dy=8mm, dz=5mm

Reference Value = 54.76 V/m; Power Drift = 0.09 dB

Peak SAR (extrapolated) = 3.45 W/kg

SAR(1 g) = 2.68 W/kg; SAR(10 g) = 2.07 W/kg

Maximum value of SAR (measured) = 2.81 W/kg

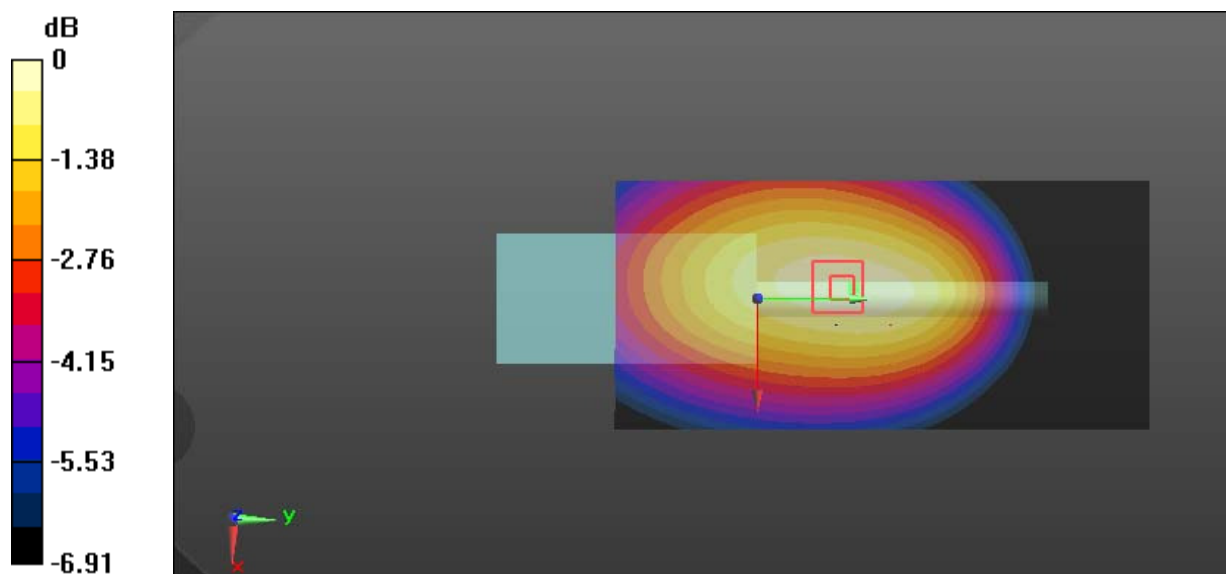

0 dB = 2.81 W/kg = 4.49 dBW/kg

Test Plot 3#: PTT_4FSK 12.5kHz_Face Up_136.0125 MHz**DUT: Digital Poratable Radio; Type: PD502i VHF; Serial: 17122000720**

Communication System: 4FSK; Frequency: 136.012 MHz; Duty Cycle: 1:2

Medium parameters used: $f = 136.012$ MHz; $\sigma = 0.768$ S/m; $\epsilon_r = 51.319$; $\rho = 1000$ kg/m³

Phantom section: Flat Section

DASY5 Configuration:

- Probe: EX3DV4 - SN7329; ConvF(12.88, 12.88, 12.88); Calibrated: 2018/1/22;
- Sensor-Surface: 1.4mm (Mechanical Surface Detection)
- Electronics: DAE4 Sn1459; Calibrated: 2017/9/15
- Phantom: ELI v8.0; Type: QDOVA004AA; Serial: 2051
- Measurement SW: DASY52, Version 52.8 (8);

Area Scan (71x151x1): Interpolated grid: dx=1.500 mm, dy=1.500 mm

Maximum value of SAR (interpolated) = 1.59 W/kg

Zoom Scan (6x7x7)/Cube 0: Measurement grid: dx=8mm, dy=8mm, dz=5mm

Reference Value = 45.98 V/m; Power Drift = -0.10 dB

Peak SAR (extrapolated) = 2.10 W/kg

SAR(1 g) = 1.52 W/kg; SAR(10 g) = 1.2 W/kg

Maximum value of SAR (measured) = 1.58 W/kg

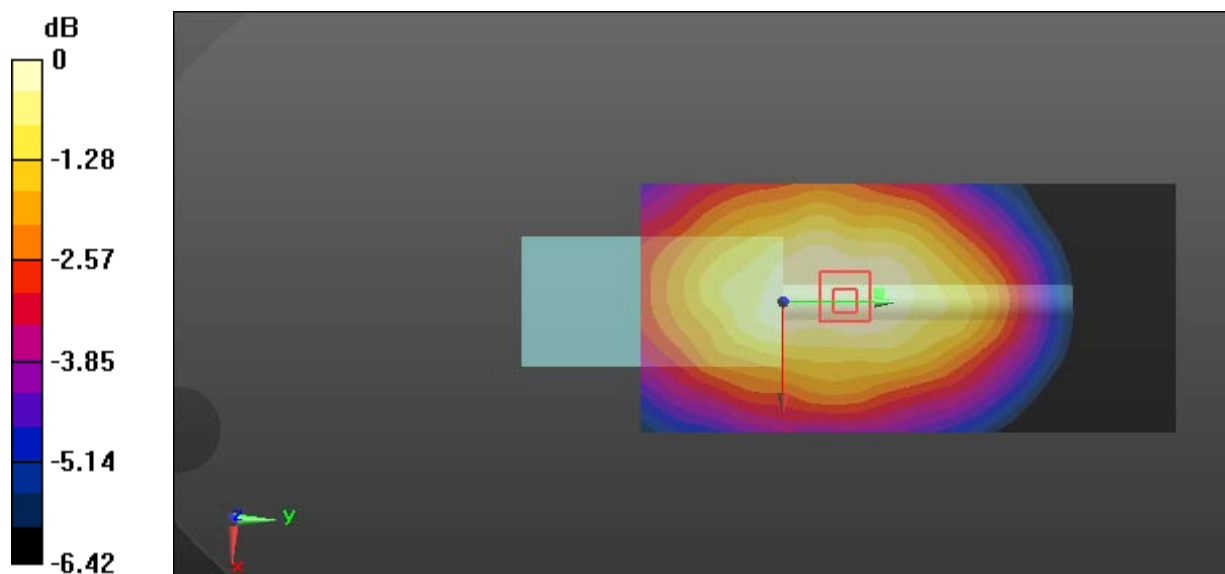

0 dB = 1.58 W/kg = 1.99 dBW/kg

Test Plot 4#: PTT_FM 12.5kHz_Body Back_136.0125 MHz**DUT: Digital Poratable Radio; Type: PD502i VHF; Serial: 17122000720**

Communication System: FM; Frequency: 136.012 MHz; Duty Cycle: 1:1

Medium parameters used: $f = 136.012$ MHz; $\sigma = 0.797$ S/m; $\epsilon_r = 61.407$; $\rho = 1000$ kg/m³

Phantom section: Flat Section

DASY5 Configuration:

- Probe: EX3DV4 - SN7329; ConvF(12.56, 12.56, 12.56); Calibrated: 2018/1/22;
- Sensor-Surface: 1.4mm (Mechanical Surface Detection)
- Electronics: DAE4 Sn1459; Calibrated: 2017/9/15
- Phantom: ELI v8.0; Type: QDOVA004AA; Serial: 2051
- Measurement SW: DASY52, Version 52.8 (8);

Area Scan (71x151x1): Interpolated grid: dx=1.500 mm, dy=1.500 mm

Maximum value of SAR (interpolated) = 6.70 W/kg

Zoom Scan (5x5x7)/Cube 0: Measurement grid: dx=8mm, dy=8mm, dz=5mm

Reference Value = 71.99 V/m; Power Drift = -0.12 dB

Peak SAR (extrapolated) = 12.2 W/kg

SAR(1 g) = 5.98 W/kg; SAR(10 g) = 3.53 W/kg

Maximum value of SAR (measured) = 6.53 W/kg

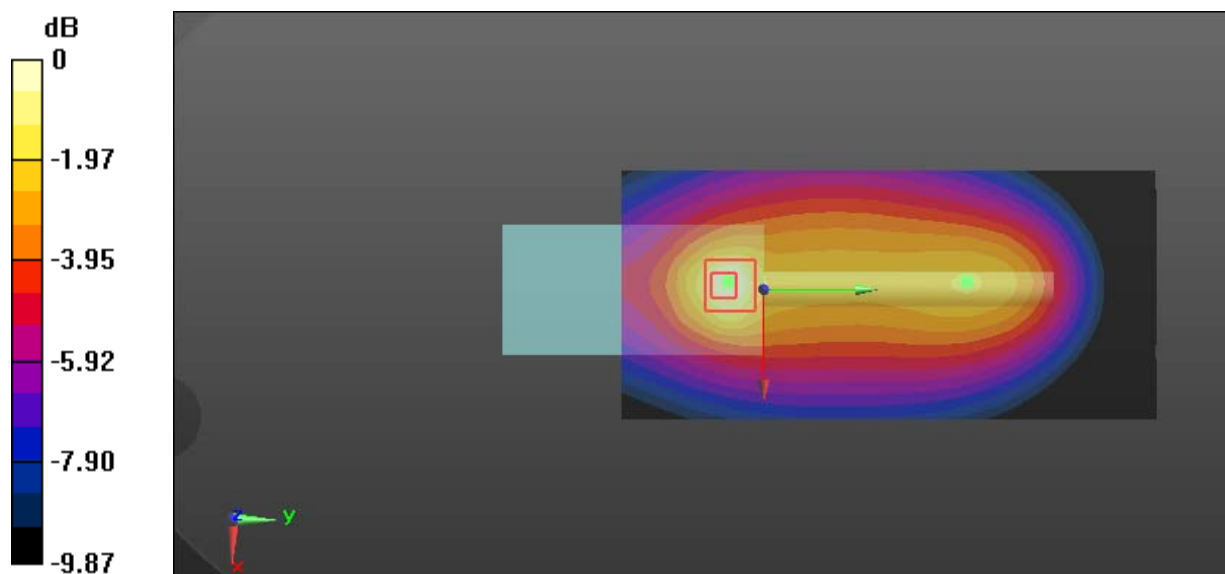

0 dB = 6.53 W/kg = 8.15 dBW/kg

Test Plot 5#: PTT_FM 25kHz_Body Back_136.0125 MHz**DUT: Digital Poratable Radio; Type: PD502i VHF; Serial: 17122000720**

Communication System: FM; Frequency: 136.012 MHz; Duty Cycle: 1:1

Medium parameters used: $f = 136.012$ MHz; $\sigma = 0.797$ S/m; $\epsilon_r = 61.407$; $\rho = 1000$ kg/m³

Phantom section: Flat Section

DASY5 Configuration:

- Probe: EX3DV4 - SN7329; ConvF(12.56, 12.56, 12.56); Calibrated: 2018/1/22;
- Sensor-Surface: 1.4mm (Mechanical Surface Detection)
- Electronics: DAE4 Sn1459; Calibrated: 2017/9/15
- Phantom: ELI v8.0; Type: QDOVA004AA; Serial: 2051
- Measurement SW: DASY52, Version 52.8 (8);

Area Scan (71x151x1): Interpolated grid: dx=1.500 mm, dy=1.500 mm

Maximum value of SAR (interpolated) = 7.06 W/kg

Zoom Scan (5x5x7)/Cube 0: Measurement grid: dx=8mm, dy=8mm, dz=5mm

Reference Value = 73.14 V/m; Power Drift = -0.15 dB

Peak SAR (extrapolated) = 10.1 W/kg

SAR(1 g) = 6.36 W/kg; SAR(10 g) = 4.26 W/kg

Maximum value of SAR (measured) = 6.73 W/kg

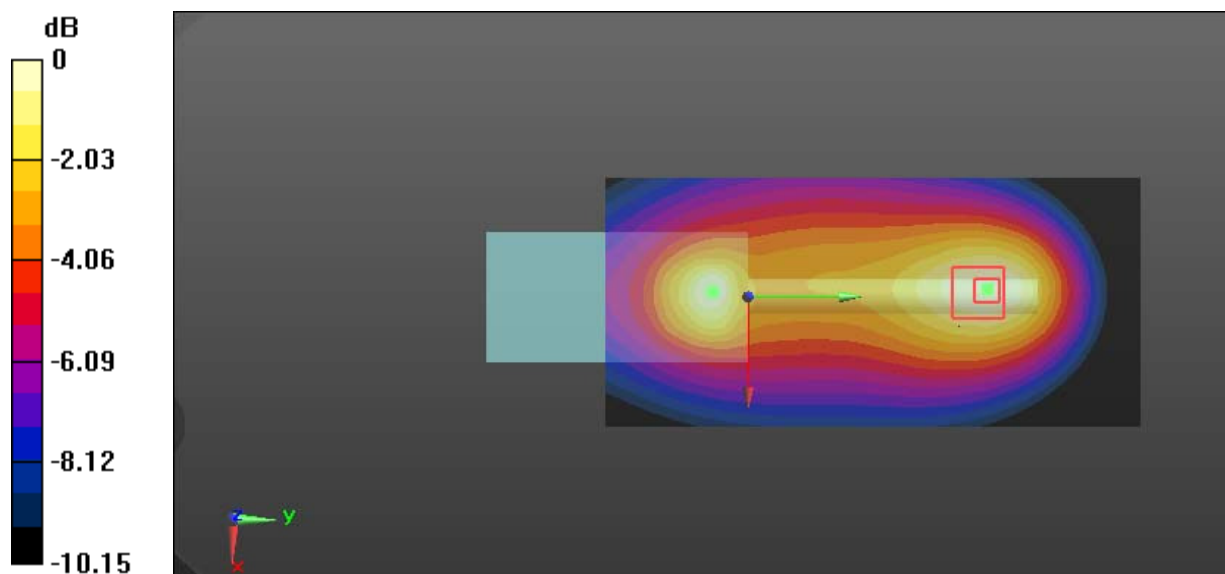

0 dB = 6.73 W/kg = 8.28 dBW/kg

Test Plot 6#: PTT_4FSK 12.5kHz_Body Back_136.0125 MHz**DUT: Digital Poratable Radio; Type: PD502i VHF; Serial: 17122000720**

Communication System: 4FSK; Frequency: 136.012 MHz; Duty Cycle: 1:2

Medium parameters used: $f = 136.012$ MHz; $\sigma = 0.797$ S/m; $\epsilon_r = 61.407$; $\rho = 1000$ kg/m³

Phantom section: Flat Section

DASY5 Configuration:

- Probe: EX3DV4 - SN7329; ConvF(12.56, 12.56, 12.56); Calibrated: 2018/1/22;
- Sensor-Surface: 1.4mm (Mechanical Surface Detection)
- Electronics: DAE4 Sn1459; Calibrated: 2017/9/15
- Phantom: ELI v8.0; Type: QDOVA004AA; Serial: 2051
- Measurement SW: DASY52, Version 52.8 (8);

Area Scan (71x151x1): Interpolated grid: dx=1.500 mm, dy=1.500 mm

Maximum value of SAR (interpolated) = 4.46 W/kg

Zoom Scan (5x5x7)/Cube 0: Measurement grid: dx=8mm, dy=8mm, dz=5mm

Reference Value = 53.14 V/m; Power Drift = -0.09 dB

Peak SAR (extrapolated) = 7.23 W/kg

SAR(1 g) = 4.17 W/kg; SAR(10 g) = 2.59 W/kg

Maximum value of SAR (measured) = 4.43 W/kg

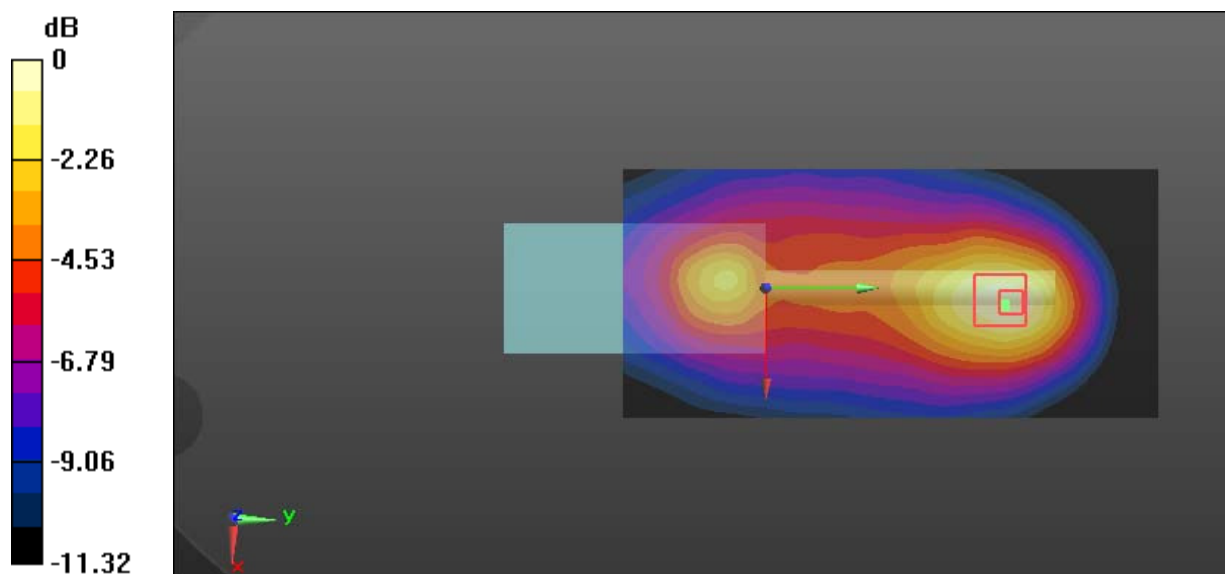

0 dB = 4.43 W/kg = 6.46 dBW/kg

Test Plot 7#: PTT_FM 12.5kHz_Face Up_154 MHz

DUT: Digital Poratable Radio; Type: PD502i VHF; Serial: 17122000720

Communication System: FM; Frequency: 154 MHz;Duty Cycle: 1:1
 Medium parameters used: $f = 154 \text{ MHz}$; $\sigma = 0.785 \text{ S/m}$; $\epsilon_r = 50.766$; $\rho = 1000 \text{ kg/m}^3$
 Phantom section: Flat Section

DASY5 Configuration:

- Probe: EX3DV4 - SN7329; ConvF(12.88, 12.88, 12.88); Calibrated: 2018/1/22;
- Sensor-Surface: 1.4mm (Mechanical Surface Detection)
- Electronics: DAE4 Sn1459; Calibrated: 2017/9/15
- Phantom: ELI v8.0; Type: QDOVA004AA; Serial: 2051
- Measurement SW: DASY52, Version 52.8 (8);

Area Scan (71x151x1): Interpolated grid: $dx=1.500 \text{ mm}$, $dy=1.500 \text{ mm}$
 Maximum value of SAR (interpolated) = 4.41 W/kg

Zoom Scan (6x7x7)/Cube 0: Measurement grid: $dx=8\text{mm}$, $dy=8\text{mm}$, $dz=5\text{mm}$
 Reference Value = 88.49 V/m; Power Drift = -0.15 dB
 Peak SAR (extrapolated) = 5.31 W/kg
SAR(1 g) = 3.21 W/kg; SAR(10 g) = 2.42 W/kg
 Maximum value of SAR (measured) = 4.32 W/kg

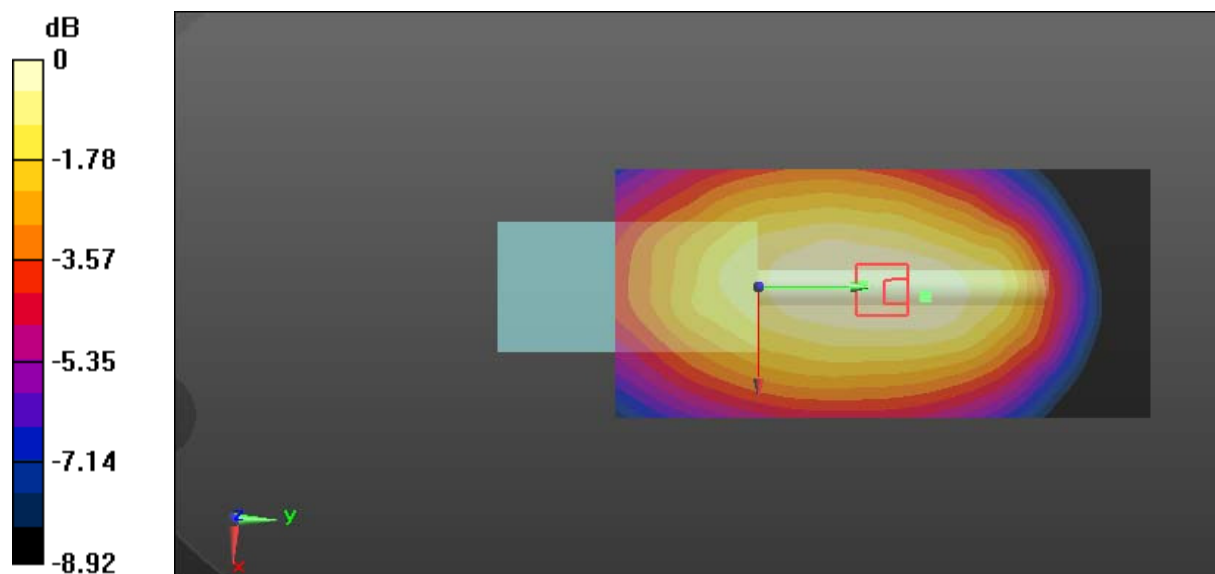

0 dB = 4.32 W/kg = 6.35 dBW/kg

Test Plot 8#: PTT_FM 25kHz_Face Up_154 MHz**DUT: Digital Poratable Radio; Type: PD502i VHF; Serial: 17122000720**

Communication System: FM; Frequency: 154 MHz; Duty Cycle: 1:1

Medium parameters used: $f = 154$ MHz; $\sigma = 0.785$ S/m; $\epsilon_r = 50.766$; $\rho = 1000$ kg/m³

Phantom section: Flat Section

DASY5 Configuration:

- Probe: EX3DV4 - SN7329; ConvF(12.88, 12.88, 12.88); Calibrated: 2018/1/22;
- Sensor-Surface: 1.4mm (Mechanical Surface Detection)
- Electronics: DAE4 Sn1459; Calibrated: 2017/9/15
- Phantom: ELI v8.0; Type: QDOVA004AA; Serial: 2051
- Measurement SW: DASY52, Version 52.8 (8);

Area Scan (71x151x1): Interpolated grid: dx=1.500 mm, dy=1.500 mm

Maximum value of SAR (interpolated) = 4.92 W/kg

Zoom Scan (6x6x7)/Cube 0: Measurement grid: dx=8mm, dy=8mm, dz=5mm

Reference Value = 64.94 V/m; Power Drift = -0.09 dB

Peak SAR (extrapolated) = 5.74 W/kg

SAR(1 g) = 3.61 W/kg; SAR(10 g) = 2.74 W/kg

Maximum value of SAR (measured) = 4.79 W/kg

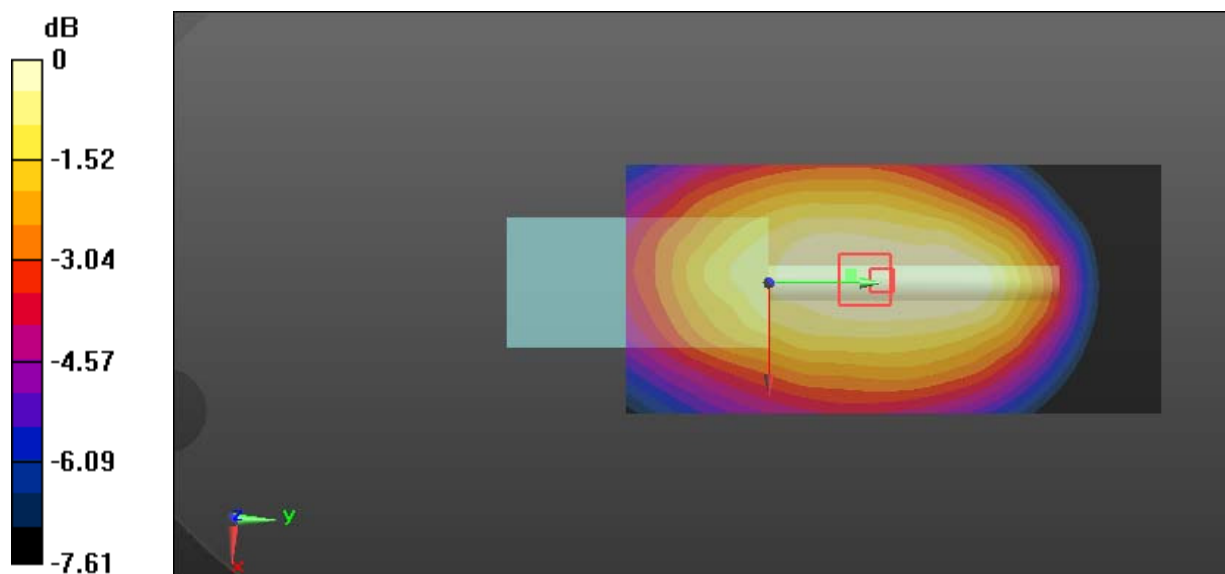

0 dB = 4.79 W/kg = 6.80 dBW/kg

Test Plot 9#: PTT_4FSK 12.5kHz_Face Up_154 MHz

DUT: Digital Poratable Radio; Type: PD502i VHF; Serial: 17122000720

Communication System: 4FSK; Frequency: 154 MHz; Duty Cycle: 1:2
 Medium parameters used: $f = 154 \text{ MHz}$; $\sigma = 0.785 \text{ S/m}$; $\epsilon_r = 50.766$; $\rho = 1000 \text{ kg/m}^3$
 Phantom section: Flat Section

DASY5 Configuration:

- Probe: EX3DV4 - SN7329; ConvF(12.88, 12.88, 12.88); Calibrated: 2018/1/22;
- Sensor-Surface: 1.4mm (Mechanical Surface Detection)
- Electronics: DAE4 Sn1459; Calibrated: 2017/9/15
- Phantom: ELI v8.0; Type: QDOVA004AA; Serial: 2051
- Measurement SW: DASY52, Version 52.8 (8);

Area Scan (71x151x1): Interpolated grid: $dx=1.500 \text{ mm}$, $dy=1.500 \text{ mm}$
 Maximum value of SAR (interpolated) = 2.35 W/kg

Zoom Scan (5x5x7)/Cube 0: Measurement grid: $dx=8\text{mm}$, $dy=8\text{mm}$, $dz=5\text{mm}$
 Reference Value = 44.67 V/m; Power Drift = 0.14 dB
 Peak SAR (extrapolated) = 3.67 W/kg
SAR(1 g) = 1.83 W/kg; SAR(10 g) = 1.34 W/kg
 Maximum value of SAR (measured) = 2.62 W/kg

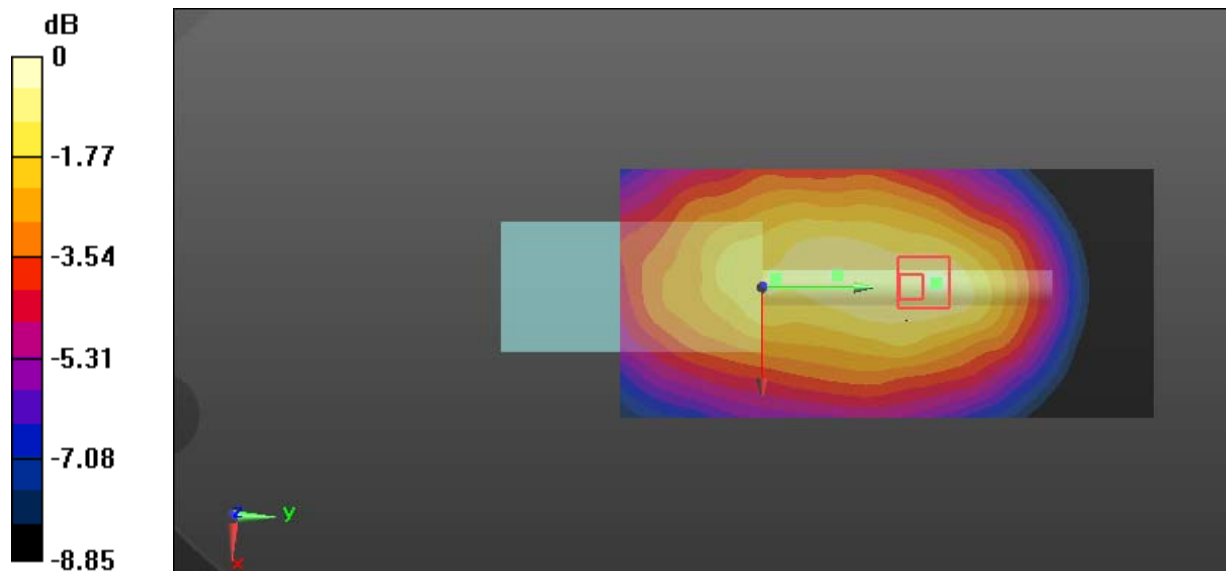

0 dB = 2.62 W/kg = 4.18 dBW/kg

Test Plot 10#: PTT_FM 12.5kHz_Body Back_147.0125 MHz

DUT: Digital Poratable Radio; Type: PD502i VHF; Serial: 17122000720

Communication System: FM; Frequency: 147.012 MHz;Duty Cycle: 1:1

Medium parameters used: $f = 147.012 \text{ MHz}$; $\sigma = 0.803 \text{ S/m}$; $\epsilon_r = 61.227$; $\rho = 1000 \text{ kg/m}^3$

Phantom section: Flat Section

DASY5 Configuration:

- Probe: EX3DV4 - SN7329; ConvF(12.56, 12.56, 12.56); Calibrated: 2018/1/22;
- Sensor-Surface: 1.4mm (Mechanical Surface Detection)
- Electronics: DAE4 Sn1459; Calibrated: 2017/9/15
- Phantom: ELI v8.0; Type: QDOVA004AA; Serial: 2051
- Measurement SW: DASY52, Version 52.8 (8);

Area Scan (71x151x1): Interpolated grid: $dx=1.500 \text{ mm}$, $dy=1.500 \text{ mm}$

Maximum value of SAR (interpolated) = 15.7 W/kg

Zoom Scan (5x5x7)/Cube 0: Measurement grid: $dx=8\text{mm}$, $dy=8\text{mm}$, $dz=5\text{mm}$

Reference Value = 65.55 V/m; Power Drift = 0.12 dB

Peak SAR (extrapolated) = 21.1 W/kg

SAR(1 g) = 7.39 W/kg; SAR(10 g) = 4.17 W/kg

Maximum value of SAR (measured) = 13.6 W/kg

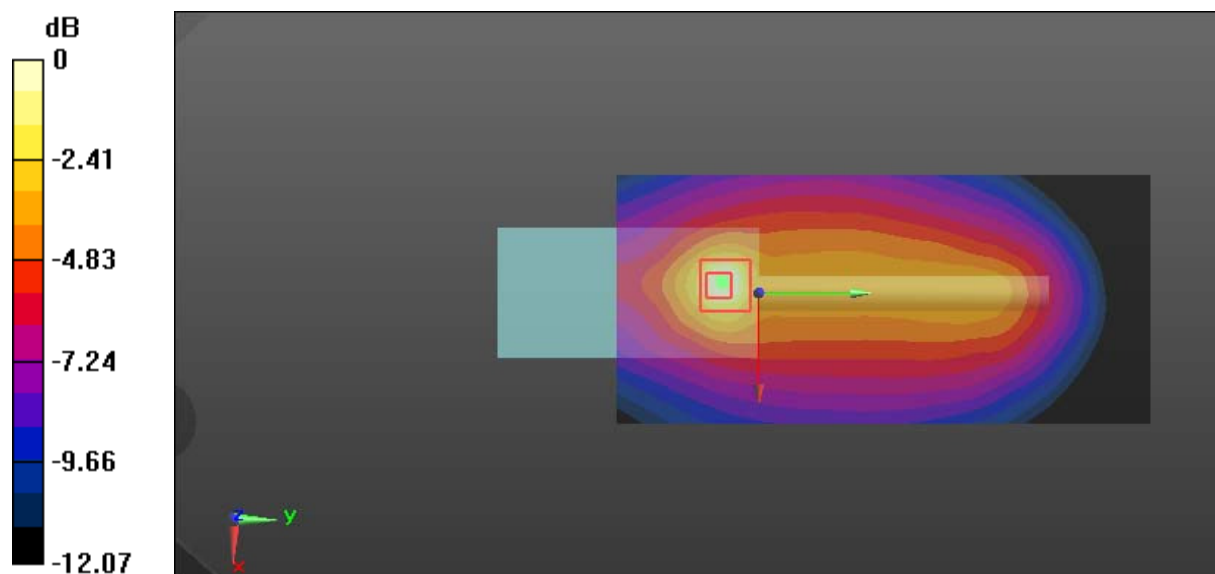

0 dB = 13.6 W/kg = 11.34 dBW/kg

Test Plot 11#: PTT_FM 12.5kHz_Body Back_154 MHz**DUT: Digital Poratable Radio; Type: PD502i VHF; Serial: 17122000720**

Communication System: FM; Frequency: 154 MHz;Duty Cycle: 1:1

Medium parameters used: $f = 154$ MHz; $\sigma = 0.802$ S/m; $\epsilon_r = 60.844$; $\rho = 1000$ kg/m³

Phantom section: Flat Section

DASY5 Configuration:

- Probe: EX3DV4 - SN7329; ConvF(12.56, 12.56, 12.56); Calibrated: 2018/1/22;
- Sensor-Surface: 1.4mm (Mechanical Surface Detection)
- Electronics: DAE4 Sn1459; Calibrated: 2017/9/15
- Phantom: ELI v8.0; Type: QDOVA004AA; Serial: 2051
- Measurement SW: DASY52, Version 52.8 (8);

Area Scan (71x151x1): Interpolated grid: dx=1.500 mm, dy=1.500 mm

Maximum value of SAR (interpolated) = 18.4 W/kg

Zoom Scan (5x5x7)/Cube 0: Measurement grid: dx=8mm, dy=8mm, dz=5mm

Reference Value = 81.52 V/m; Power Drift = 0.10 dB

Peak SAR (extrapolated) = 27.6 W/kg

SAR(1 g) = 9.74 W/kg; SAR(10 g) = 5.62 W/kg

Maximum value of SAR (measured) = 18.2 W/kg

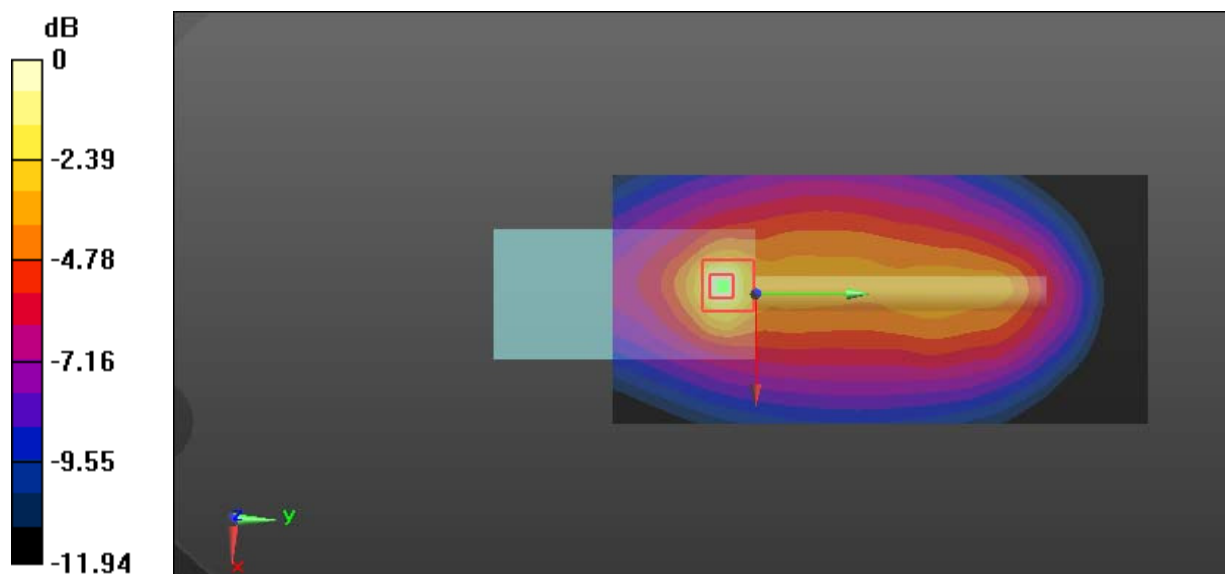

0 dB = 18.2 W/kg = 12.60 dBW/kg

Test Plot 12#: PTT_FM 12.5kHz_Body Back_159.9875 MHz**DUT: Digital Poratable Radio; Type: PD502i VHF; Serial: 17122000720**

Communication System: FM; Frequency: 159.988 MHz;Duty Cycle: 1:1

Medium parameters used: $f = 159.988$ MHz; $\sigma = 0.804$ S/m; $\epsilon_r = 60.739$; $\rho = 1000$ kg/m³

Phantom section: Flat Section

DASY5 Configuration:

- Probe: EX3DV4 - SN7329; ConvF(12.56, 12.56, 12.56); Calibrated: 2018/1/22;
- Sensor-Surface: 1.4mm (Mechanical Surface Detection)
- Electronics: DAE4 Sn1459; Calibrated: 2017/9/15
- Phantom: ELI v8.0; Type: QDOVA004AA; Serial: 2051
- Measurement SW: DASY52, Version 52.8 (8);

Area Scan (71x151x1): Interpolated grid: dx=1.500 mm, dy=1.500 mm

Maximum value of SAR (interpolated) = 13.3 W/kg

Zoom Scan (5x5x7)/Cube 0: Measurement grid: dx=8mm, dy=8mm, dz=5mm

Reference Value = 80.06 V/m; Power Drift = -0.12 dB

Peak SAR (extrapolated) = 18.9 W/kg

SAR(1 g) = 6.94 W/kg; SAR(10 g) = 4.08 W/kg

Maximum value of SAR (measured) = 12.5 W/kg

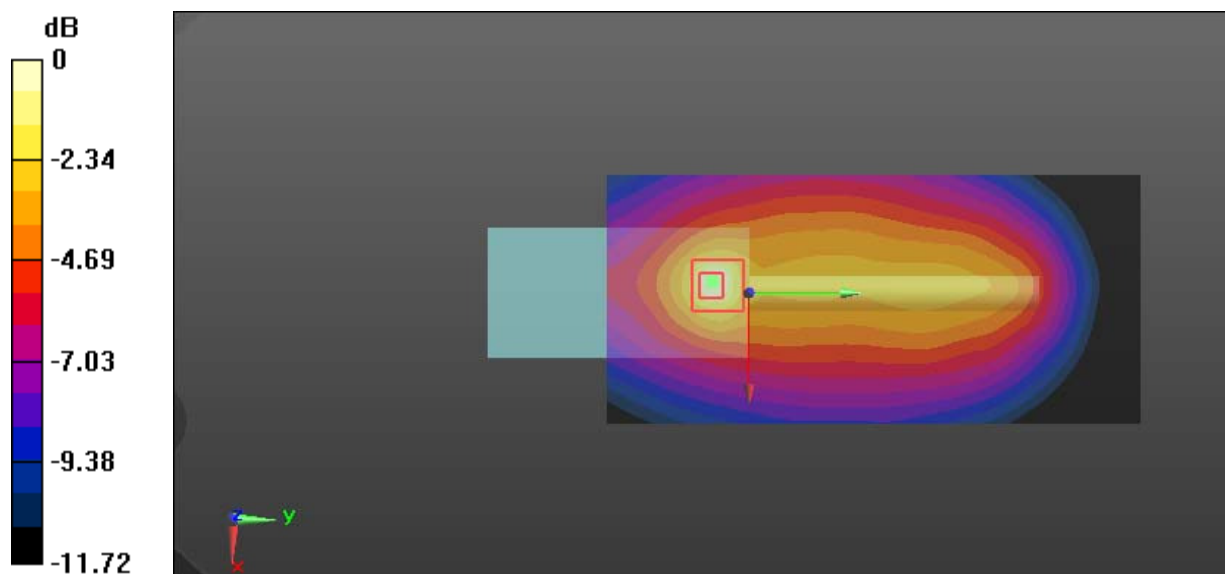

0 dB = 12.5 W/kg = 10.97 dBW/kg

Test Plot 13#: PTT_FM 25kHz_Body Back_147.0125 MHz**DUT: Digital Poratable Radio; Type: PD502i VHF; Serial: 17122000720**

Communication System: FM; Frequency: 147.012 MHz; Duty Cycle: 1:1

Medium parameters used: $f = 147.012$ MHz; $\sigma = 0.803$ S/m; $\epsilon_r = 61.227$; $\rho = 1000$ kg/m³

Phantom section: Flat Section

DASY5 Configuration:

- Probe: EX3DV4 - SN7329; ConvF(12.56, 12.56, 12.56); Calibrated: 2018/1/22;
- Sensor-Surface: 1.4mm (Mechanical Surface Detection)
- Electronics: DAE4 Sn1459; Calibrated: 2017/9/15
- Phantom: ELI v8.0; Type: QDOVA004AA; Serial: 2051
- Measurement SW: DASY52, Version 52.8 (8);

Area Scan (71x151x1): Interpolated grid: dx=1.500 mm, dy=1.500 mm

Maximum value of SAR (interpolated) = 12.2 W/kg

Zoom Scan (5x5x7)/Cube 0: Measurement grid: dx=8mm, dy=8mm, dz=5mm

Reference Value = 68.61 V/m; Power Drift = -0.06 dB

Peak SAR (extrapolated) = 24.5 W/kg

SAR(1 g) = 7.68 W/kg; SAR(10 g) = 4.09 W/kg

Maximum value of SAR (measured) = 15.2 W/kg

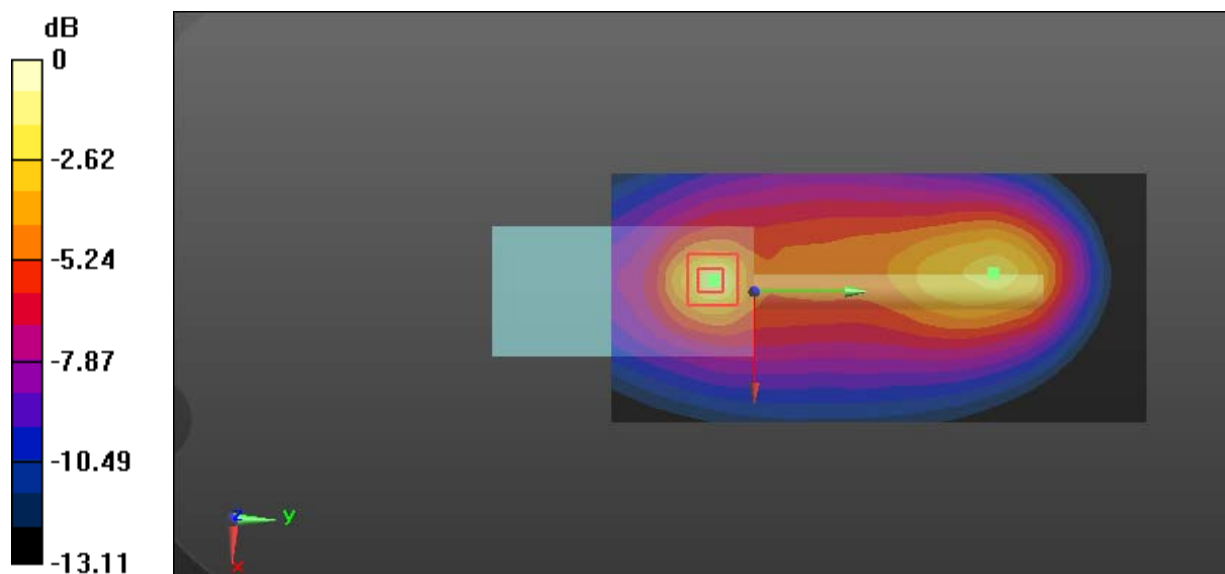

0 dB = 15.2 W/kg = 11.82 dBW/kg

Test Plot 14#: PTT_FM 25kHz_Body Back_154 MHz**DUT: Digital Poratable Radio; Type: PD502i VHF; Serial: 17122000720**

Communication System: FM; Frequency: 154 MHz; Duty Cycle: 1:1

Medium parameters used: $f = 154$ MHz; $\sigma = 0.802$ S/m; $\epsilon_r = 60.844$; $\rho = 1000$ kg/m³

Phantom section: Flat Section

DASY5 Configuration:

- Probe: EX3DV4 - SN7329; ConvF(12.56, 12.56, 12.56); Calibrated: 2018/1/22;
- Sensor-Surface: 1.4mm (Mechanical Surface Detection)
- Electronics: DAE4 Sn1459; Calibrated: 2017/9/15
- Phantom: ELI v8.0; Type: QDOVA004AA; Serial: 2051
- Measurement SW: DASY52, Version 52.8 (8);

Area Scan (71x151x1): Interpolated grid: dx=1.500 mm, dy=1.500 mm

Maximum value of SAR (interpolated) = 21.8 W/kg

Zoom Scan (5x5x7)/Cube 0: Measurement grid: dx=8mm, dy=8mm, dz=5mm

Reference Value = 82.33 V/m; Power Drift = -0.16 dB

Peak SAR (extrapolated) = 34.1 W/kg

SAR(1 g) = 10.4 W/kg; SAR(10 g) = 5.52 W/kg

Maximum value of SAR (measured) = 20.8 W/kg

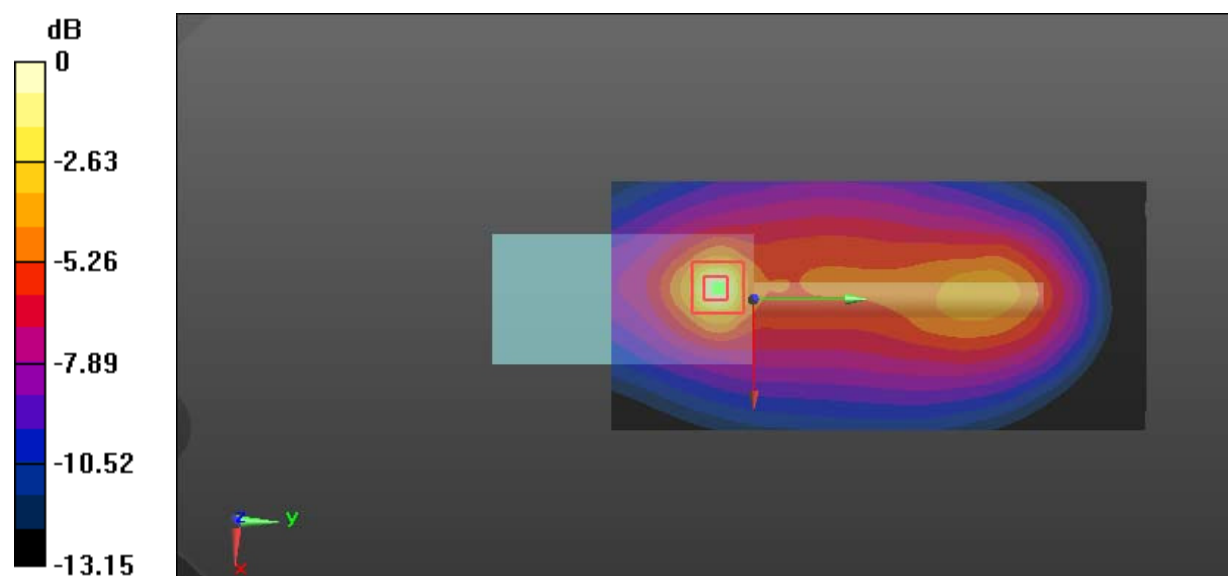

0 dB = 20.8 W/kg = 13.18 dBW/kg

Test Plot 15#: PTT_FM 25kHz_Body Back_159.9875 MHz**DUT: Digital Poratable Radio; Type: PD502i VHF; Serial: 17122000720**

Communication System: FM; Frequency: 159.988 MHz; Duty Cycle: 1:1

Medium parameters used: $f = 159.988$ MHz; $\sigma = 0.804$ S/m; $\epsilon_r = 60.739$; $\rho = 1000$ kg/m³

Phantom section: Flat Section

DASY5 Configuration:

- Probe: EX3DV4 - SN7329; ConvF(12.56, 12.56, 12.56); Calibrated: 2018/1/22;
- Sensor-Surface: 1.4mm (Mechanical Surface Detection)
- Electronics: DAE4 Sn1459; Calibrated: 2017/9/15
- Phantom: ELI v8.0; Type: QDOVA004AA; Serial: 2051
- Measurement SW: DASY52, Version 52.8 (8);

Area Scan (71x151x1): Interpolated grid: dx=1.500 mm, dy=1.500 mm

Maximum value of SAR (interpolated) = 16.3 W/kg

Zoom Scan (5x5x7)/Cube 0: Measurement grid: dx=8mm, dy=8mm, dz=5mm

Reference Value = 67.71 V/m; Power Drift = 0.08 dB

Peak SAR (extrapolated) = 24.4 W/kg

SAR(1 g) = 7.03 W/kg; SAR(10 g) = 3.75 W/kg

Maximum value of SAR (measured) = 14.6 W/kg

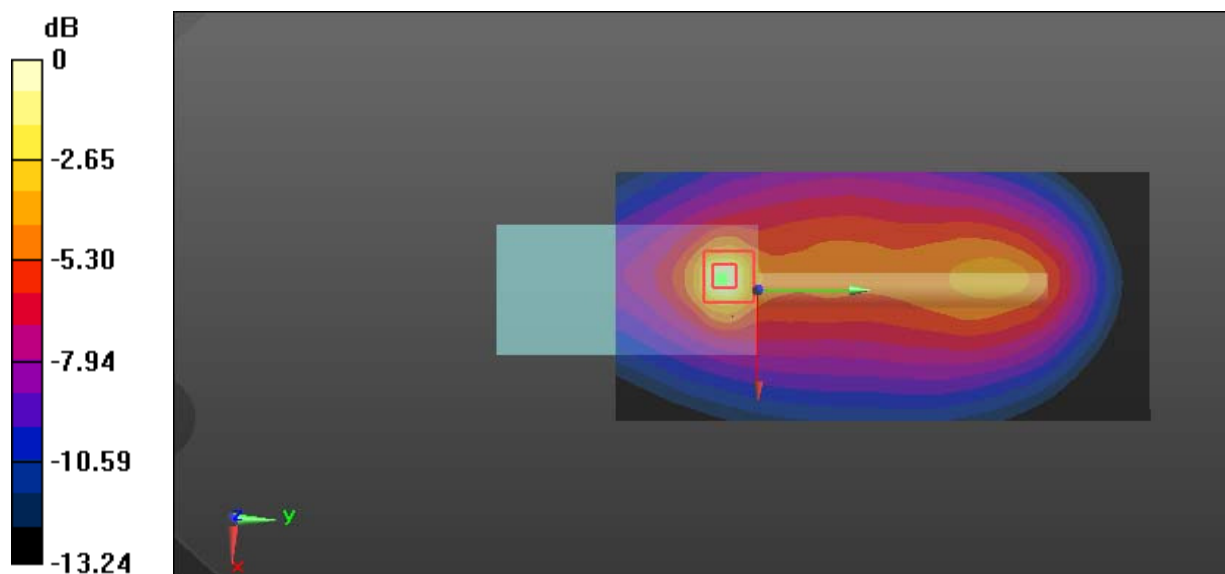

0 dB = 14.6 W/kg = 11.64 dBW/kg

Test Plot 16#: PTT_4FSK 12.5kHz_Body Back_154 MHz**DUT: Digital Poratable Radio; Type: PD502i VHF; Serial: 17122000720**

Communication System: 4FSK; Frequency: 154 MHz; Duty Cycle: 1:2

Medium parameters used: $f = 154$ MHz; $\sigma = 0.802$ S/m; $\epsilon_r = 60.844$; $\rho = 1000$ kg/m³

Phantom section: Flat Section

DASY5 Configuration:

- Probe: EX3DV4 - SN7329; ConvF(12.56, 12.56, 12.56); Calibrated: 2018/1/22;
- Sensor-Surface: 1.4mm (Mechanical Surface Detection)
- Electronics: DAE4 Sn1459; Calibrated: 2017/9/15
- Phantom: ELI v8.0; Type: QDOVA004AA; Serial: 2051
- Measurement SW: DASY52, Version 52.8 (8);

Area Scan (71x151x1): Interpolated grid: dx=1.500 mm, dy=1.500 mm

Maximum value of SAR (interpolated) = 12.2 W/kg

Zoom Scan (5x5x7)/Cube 0: Measurement grid: dx=8mm, dy=8mm, dz=5mm

Reference Value = 63.11 V/m; Power Drift = -0.16 dB

Peak SAR (extrapolated) = 26.9 W/kg

SAR(1 g) = 6.23 W/kg; SAR(10 g) = 3.12 W/kg

Maximum value of SAR (measured) = 13.5 W/kg

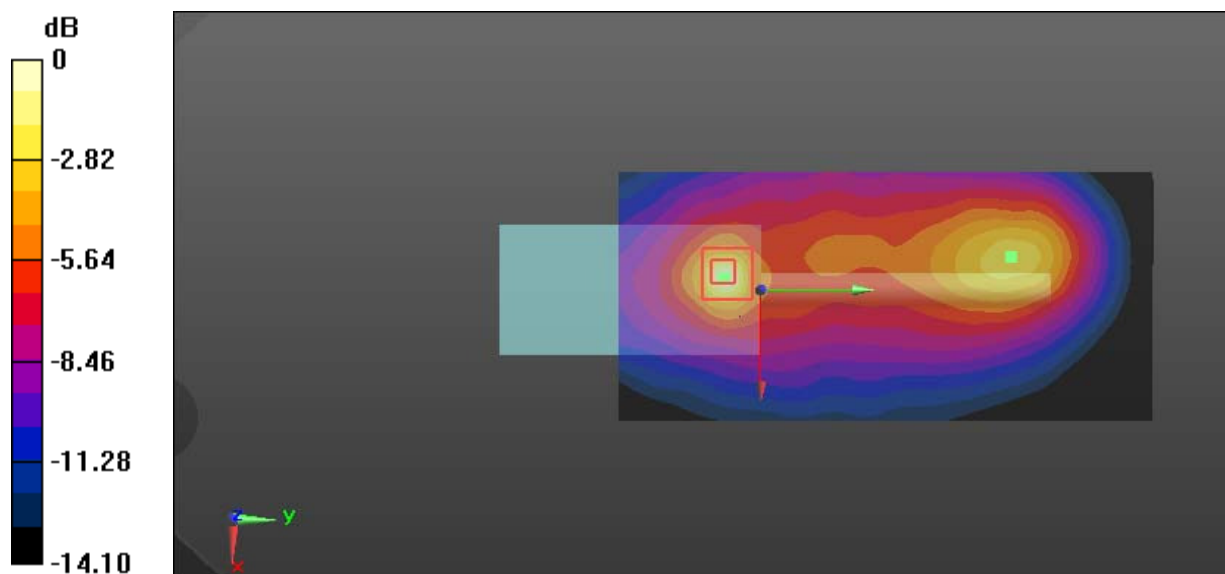

0 dB = 13.5 W/kg = 11.30 dBW/kg

Test Plot 17#: PTT_FM 12.5kHz_Face Up_160.0125 MHz

DUT: Digital Poratable Radio; Type: PD502i VHF; Serial: 17122000720

Communication System: FM; Frequency: 160.012 MHz;Duty Cycle: 1:1

Medium parameters used: $f = 160.012$ MHz; $\sigma = 0.788$ S/m; $\epsilon_r = 50.5$; $\rho = 1000$ kg/m³

Phantom section: Flat Section

DASY5 Configuration:

- Probe: EX3DV4 - SN7329; ConvF(12.88, 12.88, 12.88); Calibrated: 2018/1/22;
- Sensor-Surface: 1.4mm (Mechanical Surface Detection)
- Electronics: DAE4 Sn1459; Calibrated: 2017/9/15
- Phantom: ELI v8.0; Type: QDOVA004AA; Serial: 2051
- Measurement SW: DASY52, Version 52.8 (8);

Area Scan (71x151x1): Interpolated grid: dx=1.500 mm, dy=1.500 mm

Maximum value of SAR (interpolated) = 3.09 W/kg

Zoom Scan (6x6x7)/Cube 0: Measurement grid: dx=8mm, dy=8mm, dz=5mm

Reference Value = 54.67 V/m; Power Drift = -0.11 dB

Peak SAR (extrapolated) = 3.69 W/kg

SAR(1 g) = 2.27 W/kg; SAR(10 g) = 1.7 W/kg

Maximum value of SAR (measured) = 2.99 W/kg

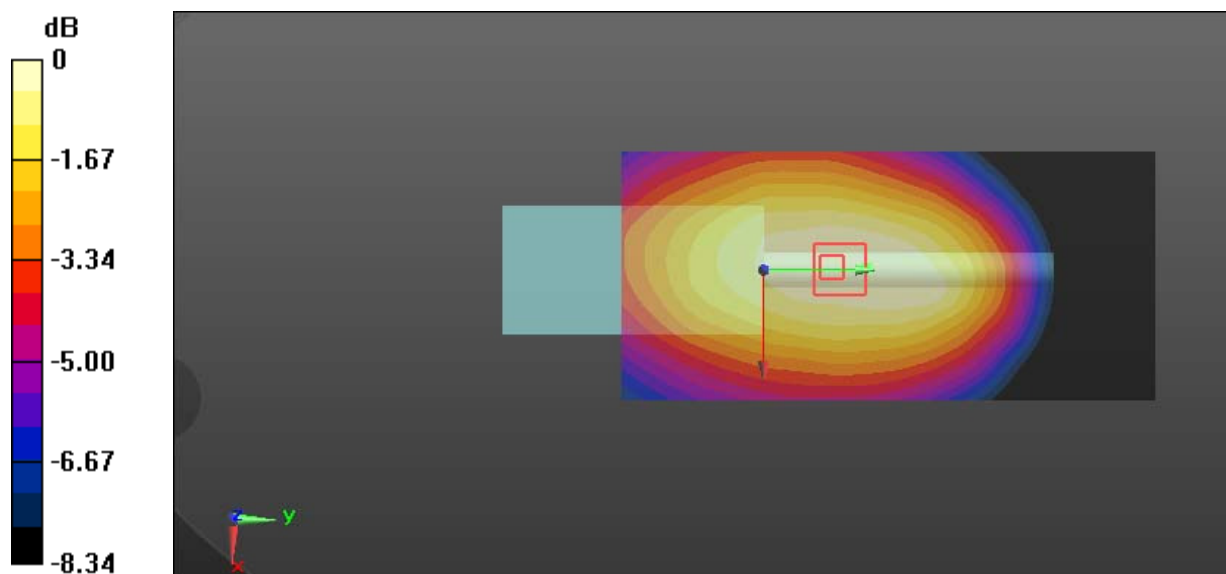

0 dB = 2.99 W/kg = 4.76 dBW/kg

Test Plot 18#: PTT_FM 25kHz_Face Up_160.0125 MHz**DUT: Digital Poratable Radio; Type: PD502i VHF; Serial: 17122000720**

Communication System: FM; Frequency: 160.012 MHz; Duty Cycle: 1:1

Medium parameters used: $f = 160.012$ MHz; $\sigma = 0.788$ S/m; $\epsilon_r = 50.5$; $\rho = 1000$ kg/m³

Phantom section: Flat Section

DASY5 Configuration:

- Probe: EX3DV4 - SN7329; ConvF(12.88, 12.88, 12.88); Calibrated: 2018/1/22;
- Sensor-Surface: 1.4mm (Mechanical Surface Detection)
- Electronics: DAE4 Sn1459; Calibrated: 2017/9/15
- Phantom: ELI v8.0; Type: QDOVA004AA; Serial: 2051
- Measurement SW: DASY52, Version 52.8 (8);

Area Scan (71x151x1): Interpolated grid: dx=1.500 mm, dy=1.500 mm

Maximum value of SAR (interpolated) = 2.74 W/kg

Zoom Scan (5x5x7)/Cube 0: Measurement grid: dx=8mm, dy=8mm, dz=5mm

Reference Value = 53.81 V/m; Power Drift = -0.04 dB

Peak SAR (extrapolated) = 3.46 W/kg

SAR(1 g) = 2.24 W/kg; SAR(10 g) = 1.7 W/kg

Maximum value of SAR (measured) = 2.92 W/kg

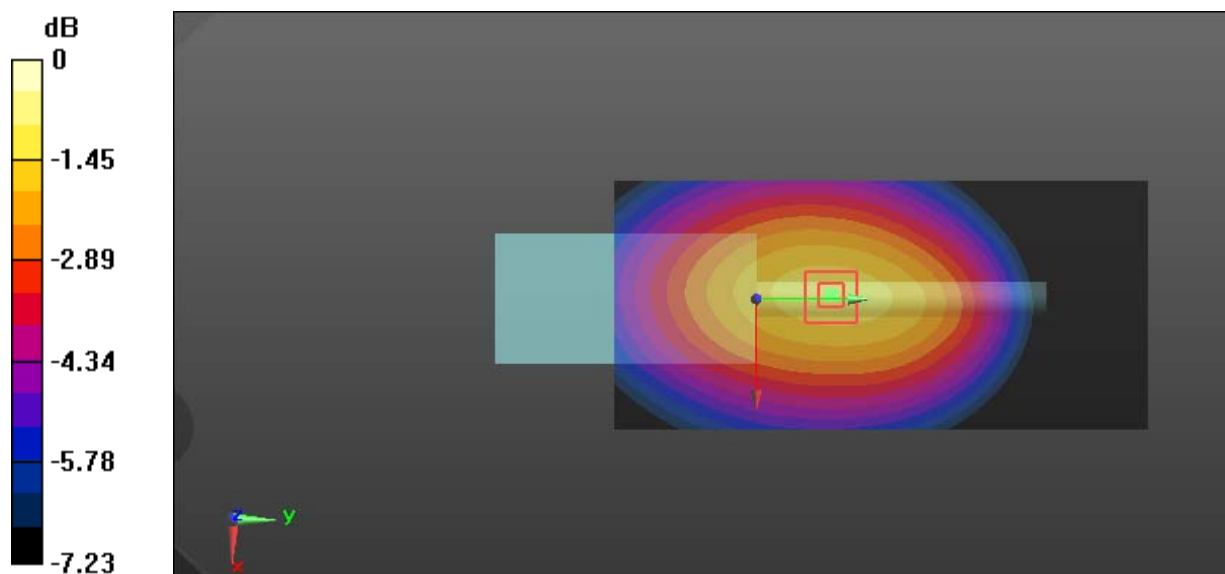

0 dB = 2.92 W/kg = 4.65 dBW/kg

Test Plot 19#: PTT_4FSK 12.5kHz_Face Up_160.0125 MHz**DUT: Digital Poratable Radio; Type: PD502i VHF; Serial: 17122000720**

Communication System: 4FSK; Frequency: 160.012 MHz; Duty Cycle: 1:2

Medium parameters used: $f = 160.012$ MHz; $\sigma = 0.788$ S/m; $\epsilon_r = 50.5$; $\rho = 1000$ kg/m³

Phantom section: Flat Section

DASY5 Configuration:

- Probe: EX3DV4 - SN7329; ConvF(12.88, 12.88, 12.88); Calibrated: 2018/1/22;
- Sensor-Surface: 1.4mm (Mechanical Surface Detection)
- Electronics: DAE4 Sn1459; Calibrated: 2017/9/15
- Phantom: ELI v8.0; Type: QDOVA004AA; Serial: 2051
- Measurement SW: DASY52, Version 52.8 (8);

Area Scan (71x151x1): Interpolated grid: dx=1.500 mm, dy=1.500 mm

Maximum value of SAR (interpolated) = 1.55 W/kg

Zoom Scan (5x5x7)/Cube 0: Measurement grid: dx=8mm, dy=8mm, dz=5mm

Reference Value = 36.98 V/m; Power Drift = -0.14 dB

Peak SAR (extrapolated) = 1.80 W/kg

SAR(1 g) = 1.15 W/kg; SAR(10 g) = 0.878 W/kg

Maximum value of SAR (measured) = 1.48 W/kg

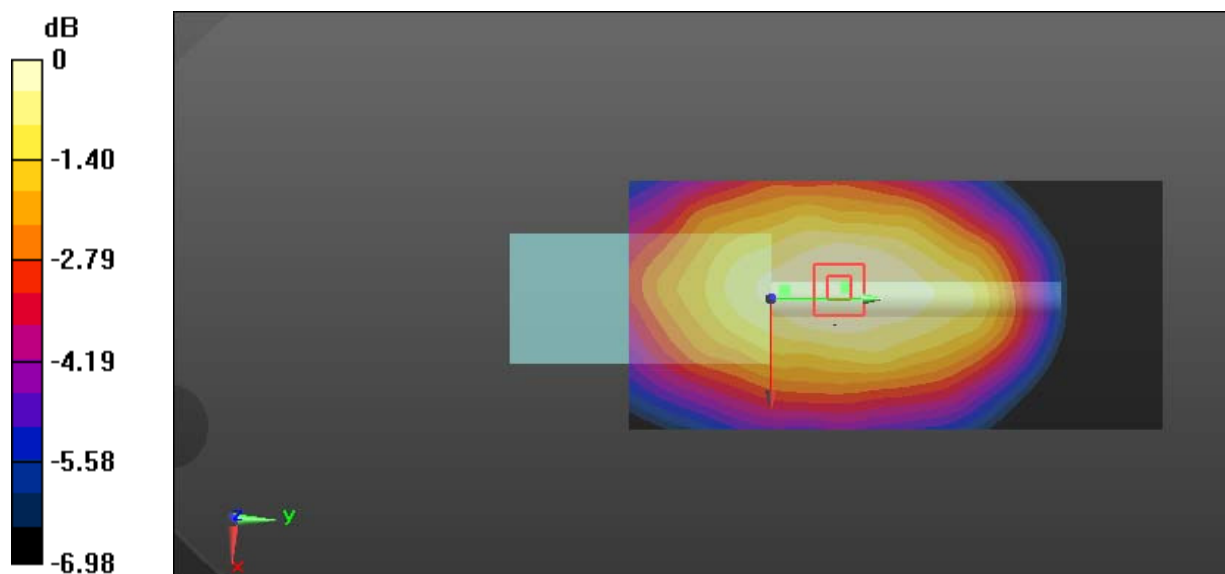

0 dB = 1.48 W/kg = 1.70 dBW/kg

Test Plot 20#: PTT_FM 12.5kHz_Body Back_160.0125 MHz**DUT: Digital Poratable Radio; Type: PD502i VHF; Serial: 17122000720**

Communication System: FM; Frequency: 160.012 MHz; Duty Cycle: 1:1

Medium parameters used: $f = 160.012$ MHz; $\sigma = 0.813$ S/m; $\epsilon_r = 60.174$; $\rho = 1000$ kg/m³

Phantom section: Flat Section

DASY5 Configuration:

- Probe: EX3DV4 - SN7329; ConvF(12.56, 12.56, 12.56); Calibrated: 2018/1/22;
- Sensor-Surface: 1.4mm (Mechanical Surface Detection)
- Electronics: DAE4 Sn1459; Calibrated: 2017/9/15
- Phantom: ELI v8.0; Type: QDOVA004AA; Serial: 2051
- Measurement SW: DASY52, Version 52.8 (8);

Area Scan (71x151x1): Interpolated grid: dx=1.500 mm, dy=1.500 mm

Maximum value of SAR (interpolated) = 14.0 W/kg

Zoom Scan (5x5x7)/Cube 0: Measurement grid: dx=8mm, dy=8mm, dz=5mm

Reference Value = 60.35 V/m; Power Drift = 0.01 dB

Peak SAR (extrapolated) = 22.7 W/kg

SAR(1 g) = 7.51 W/kg; SAR(10 g) = 4.26 W/kg

Maximum value of SAR (measured) = 14.0 W/kg

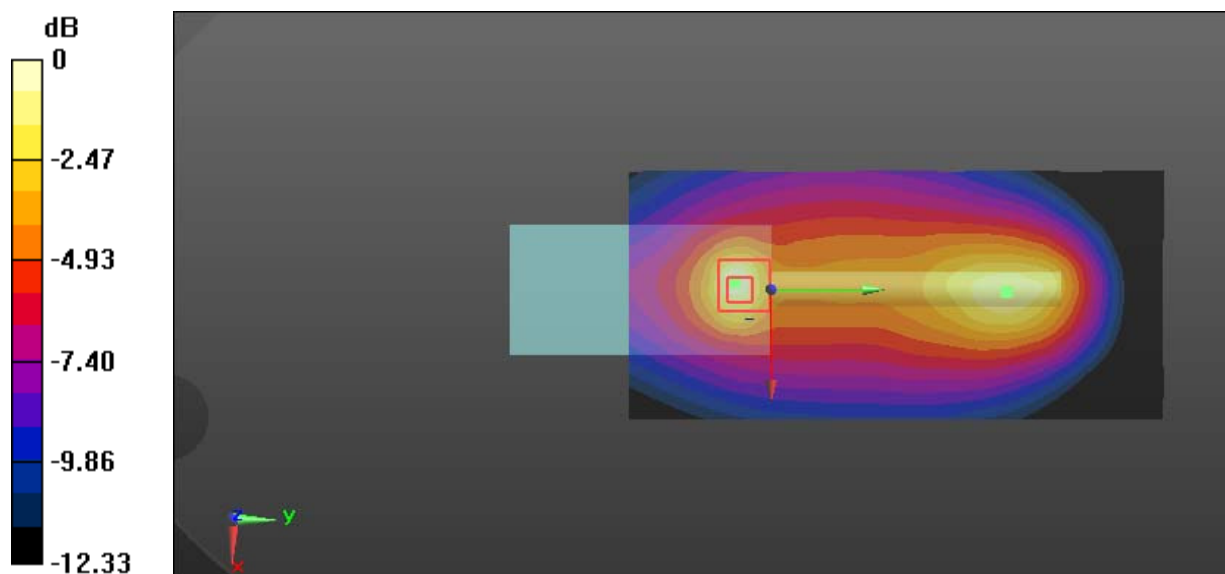

0 dB = 14.0 W/kg = 11.46 dBW/kg

Test Plot 21#: PTT_FM 12.5kHz_Body Back_167 MHz**DUT: Digital Poratable Radio; Type: PD502i VHF; Serial: 17122000720**

Communication System: FM; Frequency: 167 MHz; Duty Cycle: 1:1

Medium parameters used: $f = 167$ MHz; $\sigma = 0.814$ S/m; $\epsilon_r = 60.26$; $\rho = 1000$ kg/m³

Phantom section: Flat Section

DASY5 Configuration:

- Probe: EX3DV4 - SN7329; ConvF(12.56, 12.56, 12.56); Calibrated: 2018/1/22;
- Sensor-Surface: 1.4mm (Mechanical Surface Detection)
- Electronics: DAE4 Sn1459; Calibrated: 2017/9/15
- Phantom: ELI v8.0; Type: QDOVA004AA; Serial: 2051
- Measurement SW: DASY52, Version 52.8 (8);

Area Scan (71x151x1): Interpolated grid: dx=1.500 mm, dy=1.500 mm

Maximum value of SAR (interpolated) = 10.4 W/kg

Zoom Scan (5x5x7)/Cube 0: Measurement grid: dx=8mm, dy=8mm, dz=5mm

Reference Value = 75.62 V/m; Power Drift = -0.14 dB

Peak SAR (extrapolated) = 12.9 W/kg

SAR(1 g) = 5.39 W/kg; SAR(10 g) = 3.36 W/kg

Maximum value of SAR (measured) = 9.09 W/kg

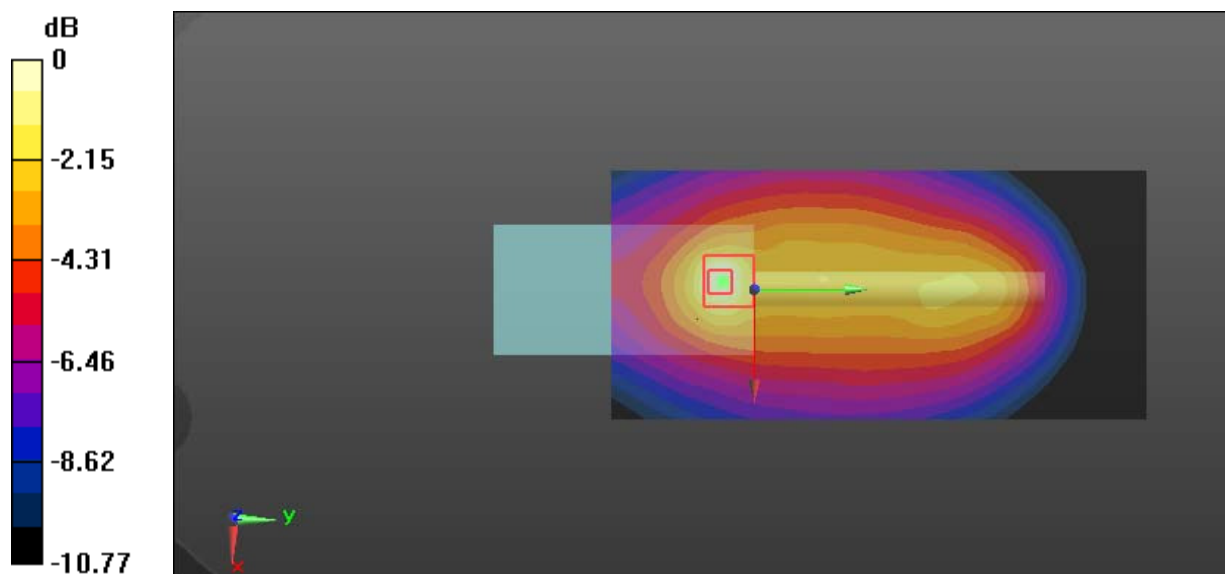

0 dB = 9.09 W/kg = 9.59 dBW/kg

Test Plot 22#: PTT_FM 12.5kHz_Body Back_173.9875 MHz**DUT: Digital Poratable Radio; Type: PD502i VHF; Serial: 17122000720**

Communication System: FM; Frequency: 173.988 MHz; Duty Cycle: 1:1

Medium parameters used: $f = 173.988$ MHz; $\sigma = 0.816$ S/m; $\epsilon_r = 60.015$; $\rho = 1000$ kg/m³

Phantom section: Flat Section

DASY5 Configuration:

- Probe: EX3DV4 - SN7329; ConvF(12.56, 12.56, 12.56); Calibrated: 2018/1/22;
- Sensor-Surface: 1.4mm (Mechanical Surface Detection)
- Electronics: DAE4 Sn1459; Calibrated: 2017/9/15
- Phantom: ELI v8.0; Type: QDOVA004AA; Serial: 2051
- Measurement SW: DASY52, Version 52.8 (8);

Area Scan (71x151x1): Interpolated grid: dx=1.500 mm, dy=1.500 mm

Maximum value of SAR (interpolated) = 4.04 W/kg

Zoom Scan (5x5x7)/Cube 0: Measurement grid: dx=8mm, dy=8mm, dz=5mm

Reference Value = 48.82 V/m; Power Drift = 0.02 dB

Peak SAR (extrapolated) = 6.79 W/kg

SAR(1 g) = 2.44 W/kg; SAR(10 g) = 1.45 W/kg

Maximum value of SAR (measured) = 4.48 W/kg

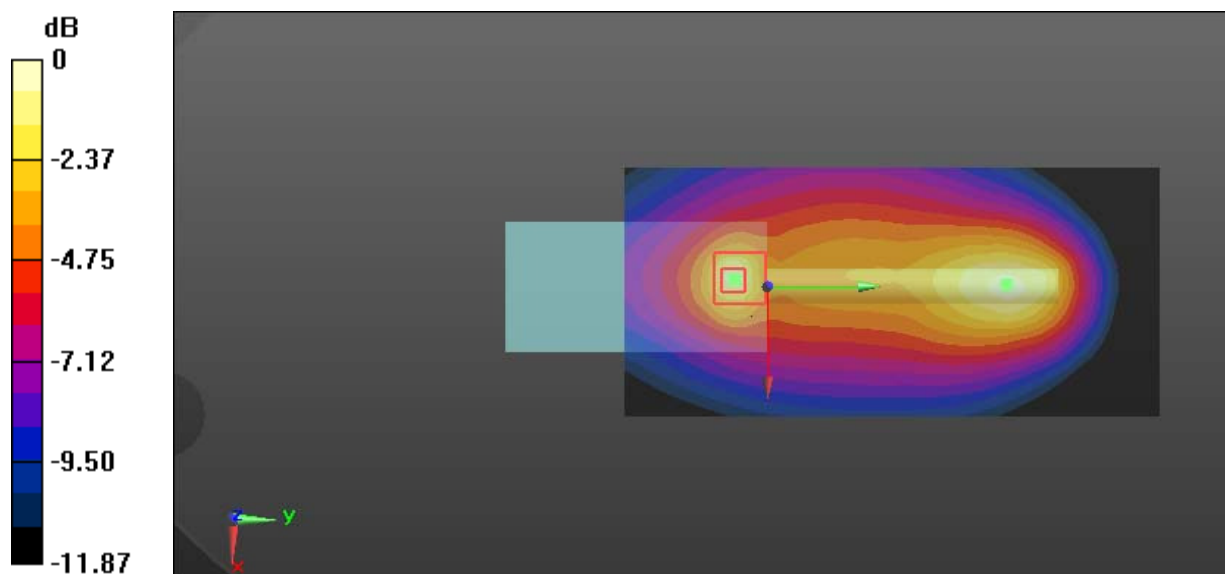

0 dB = 4.48 W/kg = 6.51 dBW/kg

Test Plot 23#: PTT_FM 25kHz_Body Back_160.0125 MHz**DUT: Digital Poratable Radio; Type: PD502i VHF; Serial: 17122000720**

Communication System: FM; Frequency: 160.012 MHz; Duty Cycle: 1:1

Medium parameters used: $f = 160.012$ MHz; $\sigma = 0.813$ S/m; $\epsilon_r = 60.174$; $\rho = 1000$ kg/m³

Phantom section: Flat Section

DASY5 Configuration:

- Probe: EX3DV4 - SN7329; ConvF(12.56, 12.56, 12.56); Calibrated: 2018/1/22;
- Sensor-Surface: 1.4mm (Mechanical Surface Detection)
- Electronics: DAE4 Sn1459; Calibrated: 2017/9/15
- Phantom: ELI v8.0; Type: QDOVA004AA; Serial: 2051
- Measurement SW: DASY52, Version 52.8 (8);

Area Scan (71x151x1): Interpolated grid: dx=1.500 mm, dy=1.500 mm

Maximum value of SAR (interpolated) = 8.24 W/kg

Zoom Scan (5x5x7)/Cube 0: Measurement grid: dx=8mm, dy=8mm, dz=5mm

Reference Value = 72.07 V/m; Power Drift = -0.13 dB

Peak SAR (extrapolated) = 25.0 W/kg

SAR(1 g) = 7.49 W/kg; SAR(10 g) = 4.01 W/kg

Maximum value of SAR (measured) = 15.0 W/kg

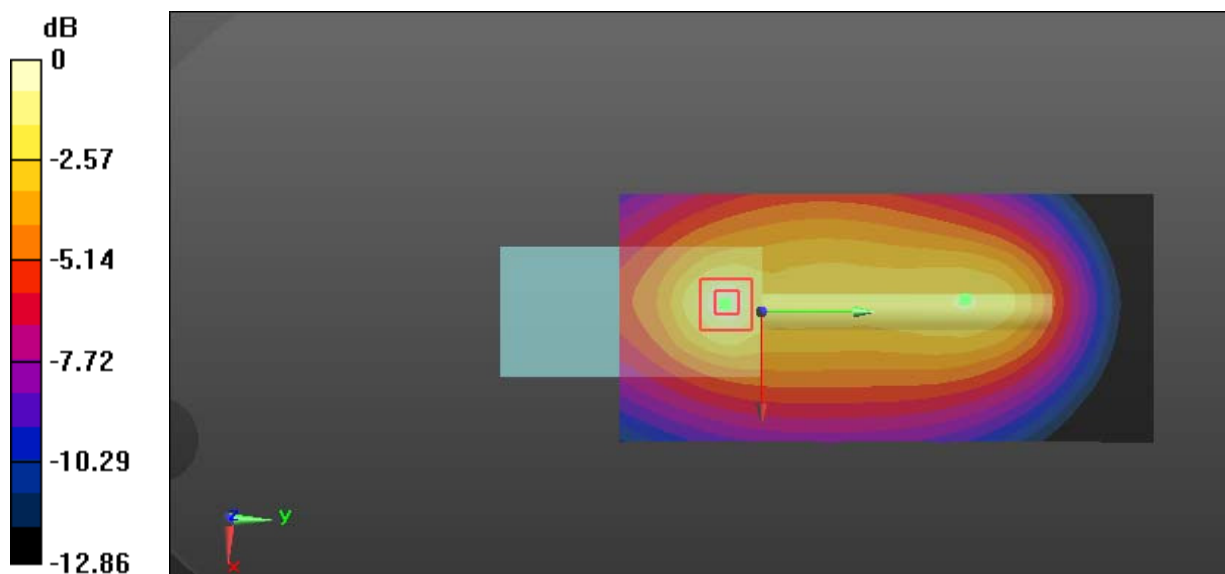

0 dB = 15.0 W/kg = 11.76 dBW/kg

Test Plot 24#: PTT_FM 25kHz_Body Back_167 MHz**DUT: Digital Poratable Radio; Type: PD502i VHF; Serial: 17122000720**

Communication System: FM; Frequency: 167 MHz; Duty Cycle: 1:1

Medium parameters used: $f = 167$ MHz; $\sigma = 0.814$ S/m; $\epsilon_r = 60.26$; $\rho = 1000$ kg/m³

Phantom section: Flat Section

DASY5 Configuration:

- Probe: EX3DV4 - SN7329; ConvF(12.56, 12.56, 12.56); Calibrated: 2018/1/22;
- Sensor-Surface: 1.4mm (Mechanical Surface Detection)
- Electronics: DAE4 Sn1459; Calibrated: 2017/9/15
- Phantom: ELI v8.0; Type: QDOVA004AA; Serial: 2051
- Measurement SW: DASY52, Version 52.8 (8);

Area Scan (71x151x1): Interpolated grid: dx=1.500 mm, dy=1.500 mm

Maximum value of SAR (interpolated) = 9.58 W/kg

Zoom Scan (5x5x7)/Cube 0: Measurement grid: dx=8mm, dy=8mm, dz=5mm

Reference Value = 69.27 V/m; Power Drift = -0.07 dB

Peak SAR (extrapolated) = 15.6 W/kg

SAR(1 g) = 4.96 W/kg; SAR(10 g) = 2.76 W/kg

Maximum value of SAR (measured) = 9.70 W/kg

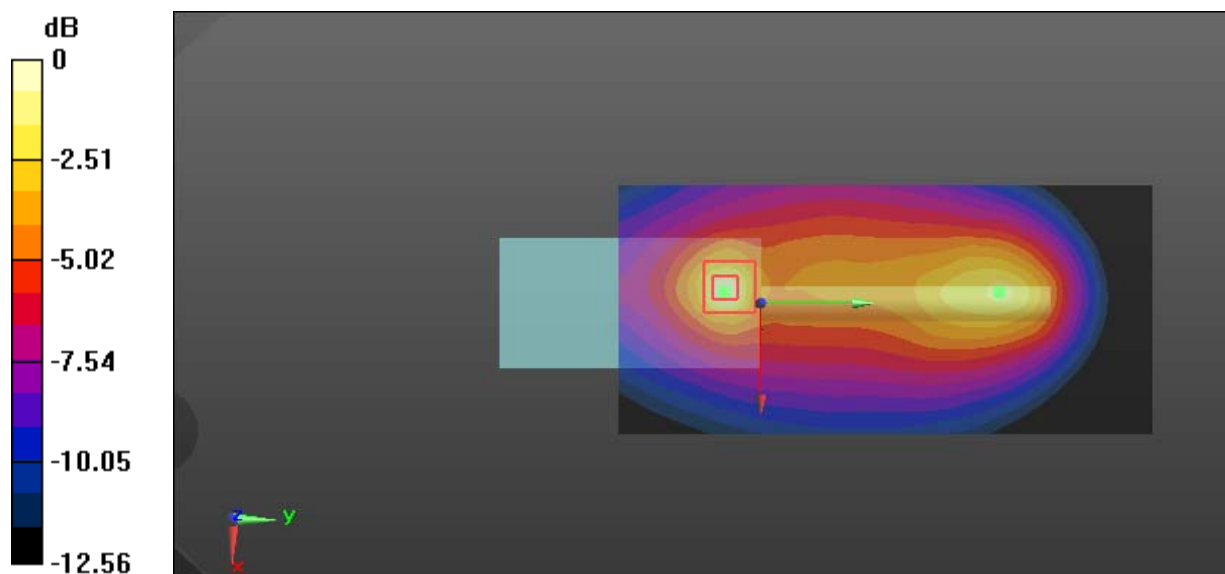

0 dB = 9.70 W/kg = 9.87 dBW/kg

Test Plot 25#: PTT_FM 25kHz_Body Back_173.9875 MHz**DUT: Digital Poratable Radio; Type: PD502i VHF; Serial: 17122000720**

Communication System: FM; Frequency: 173.988 MHz;Duty Cycle: 1:1

Medium parameters used: $f = 173.988$ MHz; $\sigma = 0.816$ S/m; $\epsilon_r = 60.015$; $\rho = 1000$ kg/m³

Phantom section: Flat Section

DASY5 Configuration:

- Probe: EX3DV4 - SN7329; ConvF(12.56, 12.56, 12.56); Calibrated: 2018/1/22;
- Sensor-Surface: 1.4mm (Mechanical Surface Detection)
- Electronics: DAE4 Sn1459; Calibrated: 2017/9/15
- Phantom: ELI v8.0; Type: QDOVA004AA; Serial: 2051
- Measurement SW: DASY52, Version 52.8 (8);

Area Scan (71x151x1): Interpolated grid: dx=1.500 mm, dy=1.500 mm

Maximum value of SAR (interpolated) = 4.61 W/kg

Zoom Scan (5x5x7)/Cube 0: Measurement grid: dx=8mm, dy=8mm, dz=5mm

Reference Value = 47.16 V/m; Power Drift = 0.09 dB

Peak SAR (extrapolated) = 8.28 W/kg

SAR(1 g) = 2.88 W/kg; SAR(10 g) = 1.66 W/kg

Maximum value of SAR (measured) = 5.50 W/kg

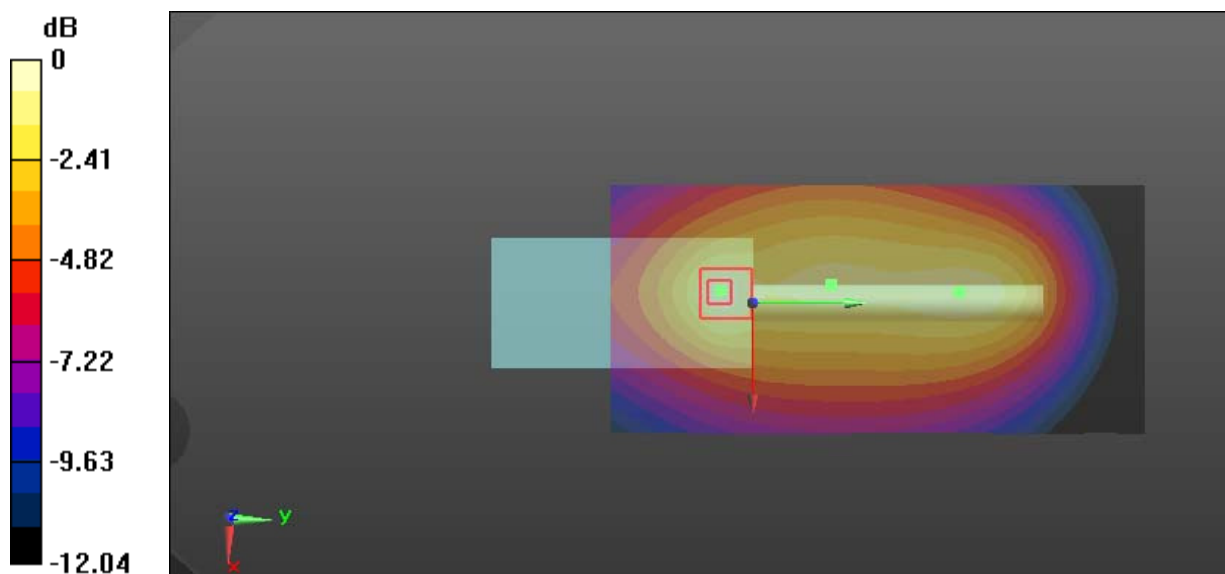

0 dB = 5.50 W/kg = 7.40 dBW/kg

Test Plot 26#: PTT_4FSK 12.5kHz_Body Back_160.0125 MHz**DUT: Digital Poratable Radio; Type: PD502i VHF; Serial: 17122000720**

Communication System: 4FSK; Frequency: 160.012 MHz; Duty Cycle: 1:2

Medium parameters used: $f = 160.012$ MHz; $\sigma = 0.813$ S/m; $\epsilon_r = 60.174$; $\rho = 1000$ kg/m³

Phantom section: Flat Section

DASY5 Configuration:

- Probe: EX3DV4 - SN7329; ConvF(12.56, 12.56, 12.56); Calibrated: 2018/1/22;
- Sensor-Surface: 1.4mm (Mechanical Surface Detection)
- Electronics: DAE4 Sn1459; Calibrated: 2017/9/15
- Phantom: ELI v8.0; Type: QDOVA004AA; Serial: 2051
- Measurement SW: DASY52, Version 52.8 (8);

Area Scan (71x151x1): Interpolated grid: dx=1.500 mm, dy=1.500 mm

Maximum value of SAR (interpolated) = 7.19 W/kg

Zoom Scan (5x5x7)/Cube 0: Measurement grid: dx=8mm, dy=8mm, dz=5mm

Reference Value = 49.12 V/m; Power Drift = -0.00 dB

Peak SAR (extrapolated) = 18.1 W/kg

SAR(1 g) = 4.25 W/kg; SAR(10 g) = 2.17 W/kg

Maximum value of SAR (measured) = 8.79 W/kg

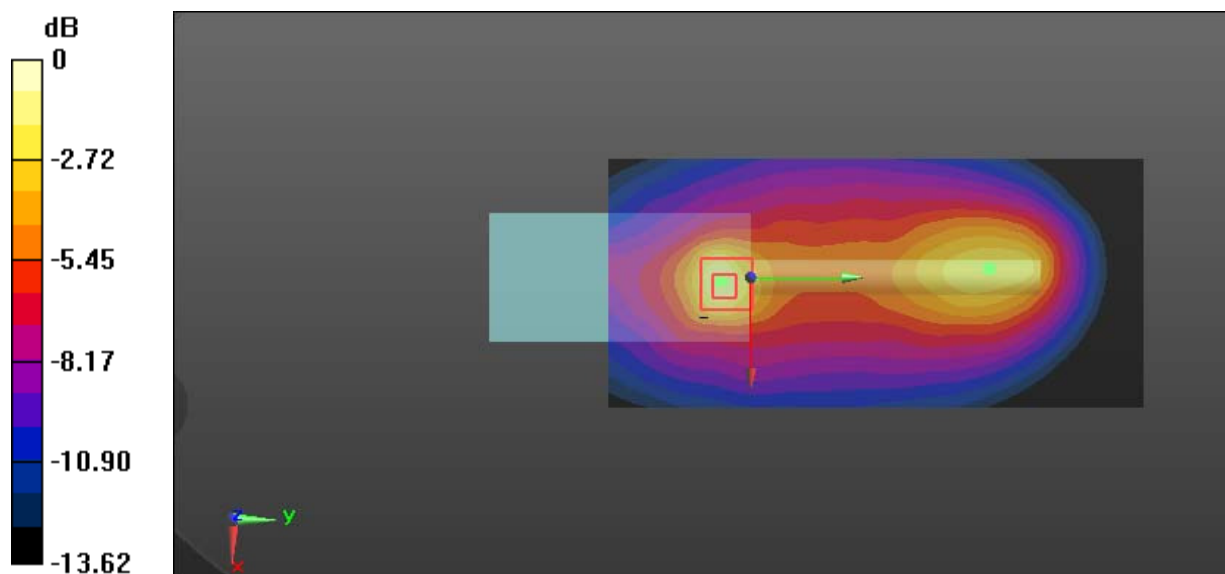

0 dB = 8.79 W/kg = 9.44 dBW/kg