



FCC PART 90 TEST REPORT

FCC Part 90

Report Reference No......: **TRE1311014701 R/C: 84170**

FCC ID.....: **YAMMD65XU1**

Compiled by

(position+printed name+signature)..: File administrators Jerome Luo

Jerome Luo

Supervised by

(position+printed name+signature)..: Test Engineer Yuchao Wang

yuchao.wang

Approved by

(position+printed name+signature)..: Manager Wenliang Li

Wenliang Li

Date of issue.....: Dec 16, 2013

Testing Laboratory Name: **Shenzhen Huatongwei International Inspection Co., Ltd**

Address.....: Keji Nan No.12 Road, Hi-tech Park, Shenzhen, China

Applicant's name: **Hytera Communications Corporation Ltd.**

Address.....: HYT Tower,Hi-Tech Industrial Park North,Nanshan District,Shenzhen China.518057

Test specification

Standard: **FCC Part 90/FCC Part 2/ FCC Part 15B**

TRF Originator.....: Shenzhen Huatongwei International Inspection CO., Ltd

Master TRF: Dated 2006-06

Shenzhen Huatongwei International Inspection Co., Ltd. All rights reserved.

This publication may be reproduced in whole or in part for non-commercial purposes as long as the Shenzhen Huatongwei International Inspection Co., Ltd is acknowledged as copyright owner and source of the material. Shenzhen Huatongwei International Inspection Co., Ltd takes no responsibility for and will not assume liability for damages resulting from the reader's interpretation of the reproduced material due to its placement and context.

Test item description

Digital Mobile Radio

Trade Mark



Manufacturer: **Hytera Communications Corporation Ltd.**

Model/Type reference.....: MD652 U(1)

Listed Models: MD650 U(1), MD655 U(1), MD656 U(1),MD658 U(1)

Ratings.....: DC 13.6V

Modulation: FM&4FSK

Channel Separation.....: 12.5KHz

Rated Power: 25 Watts(43.98dBm)/1Watts(30.00dBm)

Operation Frequency Range: From 400 MHz to 470 MHz

Result.....: **PASS**

TEST REPORT

Test Report No. :	TRE1311014701	Dec 16, 2013
		Date of issue

Equipment under Test : Digital Mobile Radio

Model /Type : MD652 U(1)

Listed Models : MD650 U(1), MD655 U(1), MD656 U(1),MD658 U(1)

Applicant : **Hytera Communications Corporation Ltd.**

Address : HYT Tower,Hi-Tech Industrial Park North,Nanshan District,Shenzhen China.518057

Manufacturer : **Hytera Communications Corporation Ltd.**

Address : HYT Tower,Hi-Tech Industrial Park North,Nanshan District,Shenzhen China.518057

Test Result	PASS
--------------------	-------------

The test report merely corresponds to the test sample.
It is not permitted to copy extracts of these test result without the written permission of the test laboratory.

Contents

1.	<u>TEST STANDARDS</u>	4
2.	<u>SUMMARY</u>	5
2.1.	General Remarks	5
2.2.	Product Description	5
2.3.	Equipment under Test	5
2.4.	Short description of the Equipment under Test (EUT)	6
2.5.	EUT Configuration	6
2.6.	EUT operation mode	6
2.7.	EUT configuration	6
2.8.	Related Submittal(s) / Grant (s)	6
2.9.	Modifications	6
2.10.	Note	6
3.	<u>TEST ENVIRONMENT</u>	7
3.1.	Address of the test laboratory	7
3.2.	Test Facility	7
3.3.	Environmental conditions	8
3.4.	Configuration of Tested System	8
3.5.	Statement of the measurement uncertainty	8
3.6.	Test Description	9
3.7.	Equipments Used during the Test	9
4.	<u>TEST CONDITIONS AND RESULTS</u>	11
4.1.	Conducted Emissions Test	11
4.2.	Occupied Bandwidth and Emission Mask Test	14
4.3.	Transmitter Radiated Spurious Emssion	22
4.4.	Spurious Emssion on Antenna Port	26
4.5.	Modulation Charcateristics	46
4.6.	Frequency Stability Test	49
4.7.	Maximum Transmitter Power	51
4.8.	Transmitter Frequency Behavior	58
4.9.	Receiver Radiated Spurious Emssion	61
4.10.	Receiver Conducted Spurious Emssion	67
5.	<u>TEST SETUP PHOTOS OF THE EUT</u>	74
6.	<u>EXTERNAL AND INTERNAL PHOTOS OF THE EUT</u>	77

1. TEST STANDARDS

The tests were performed according to following standards:

[FCC Rules Part 90 :10-01-2013:](#) PRIVATE LAND MOBILE RADIO SERVICES.

[TIA/EIA 603 D:June 2010:](#) Land Mobile FM or PM Communications Equipment Measurement and Performance Standards.

[47 CFR FCC Part 15 Subpart B: 10-01-2013](#) - Unintentional Radiators

[FCC Part 210-01-2013:](#) FREQUENCY ALLOCA-TIONS AND RADIO TREATY MAT-TERS; GENERAL RULES AND REG-ULATIONS

2. SUMMARY

2.1. General Remarks

Date of receipt of test sample	:	Nov 12, 2013
Testing commenced on	:	Nov 12, 2013
Testing concluded on	:	Dec 16, 2013

2.2. Product Description

The Hytera Communications Corporation Ltd.'s Model: RD652 U(1) or the "EUT" as referred to in this report; more general information as follows, for more details, refer to the user's manual of the EUT.

Name of EUT	Digital Mobile Radio	
Model Number	MD650 U(1), MD652 U(1), MD655 U(1), MD656 U(1),MD658 U(1)	
FCC ID	YAMMD65XU1	
Rated Output Power	25 Watts(43.98dBm)/1 Watts(30.00dBm)	
Support data rate	9.6kbps	
Modulation Type	FM for Analog Voice	
	4FSK for Digital Voice/Digital Data	
	4FSK for Digital Data	
	Analog	11K0F3E for 12.5KHz Channel Separation
Digital	7K60FXD for Digital Data only	
	7K60FXW for Digital Data & Digital Voice	
Channel Separation	Analog Voice	12.5KHz
	Digital Voice/Data	12.5KHz
	Digital Data	12.5KHz
Antenna Type	External	
Frequency Range	From 406 MHz to 470 MHz	
Maximum Transmitter Power	Analog	29.51W for 12.5 KHz Channel Separation
	Digital	29.79W for 12.5 KHz Channel Separation

Note: The product has the same digital working characters when operating in both two digitized voice/data mode (7K60FXD and 7K60FXW). So only one set of test results for digital modulation modes are provided in this test report.

2.3. Equipment under Test

Power supply system utilised

Power supply voltage	:	<input type="radio"/> 120V / 60 Hz	<input type="radio"/> 115V / 60Hz
		<input type="radio"/> 12 V DC	<input type="radio"/> 24 V DC
		<input checked="" type="radio"/> Other (specified in blank below)	

DC 13.60V

Test frequency list

Modulation Type	Test Channel	Channel Separation	Test Frequency (MHz)
Analog/FM	Ch1	12.5KHz	406.5
	Ch2		435.0
	Ch3		469.5
Digital/4FSK	Ch4	12.5KHz	406.5
	Ch5		435.0
	Ch6		469.5

2.4. Short description of the Equipment under Test (EUT)

400-470 MHz U frequency band Digital Mobile Radio.

For more details, refer to the user's manual of the EUT.

2.5. EUT Configuration

The EUT configuration for testing is installed on RF field strength measurement to meet the Commission's requirement and operating in a manner which intends to maximize its emission characteristics in a continuous normal application.

2.6. EUT operation mode

The EUT has been tested under typical operating condition and The Transmitter was operated in the normal operating mode. The TX frequency was fixed which was for the purpose of the measurements.

EUT operation mode no.	Description of operation mode	Additional information
Op 1	FM+BW12.5KHz+TX	The equipment is set with FM modulation and 12.5KHz bandwidth at maximum rated power for transmitter, powered by DC 13.60V
Op 2	FM+BW12.5KHz+TX	The equipment is set with FM modulation and 12.5KHz bandwidth at minimum rated power for transmitter, powered by DC 13.60V
Op 3	4FSK+BW12.5KHz+TX	The equipment is set with 4FSK modulation and 12.5KHz bandwidth at maximum rated power for transmitter, powered by DC 13.60V
Op 4	4FSK+BW12.5KHz+TX	The equipment is set with 4FSK modulation and 12.5KHz bandwidth at minimum rated power for transmitter, powered by DC 13.60V
Op 5	FM+BW12.5KHz+RX	The equipment is set to 12.5KHz bandwidth FM channel for receiver, powered by DC 13.60V
Op 6	4FSK+BW12.5KHz+RX	The equipment is set to 12.5KHz bandwidth Digital channel for receiver, powered by DC 13.60V

2.7. EUT configuration

The following peripheral devices and interface cables were connected during the measurement:

● - supplied by the manufacturer

○ - supplied by the lab

● Power Cable	Length (m) :	3.00
	Shield :	Unshielded
	Detachable :	Undetachable
○ Multimeter	Manufacturer :	/
	Model No. :	/

2.8. Related Submittal(s) / Grant (s)

This submittal(s) (test report) is intended for **FCC ID: YAMMD65XU1** filing to comply with FCC Part 90 rules.

2.9. Modifications

No modifications were implemented to meet testing criteria.

2.10. Note

- The EUT is a U frequency band (400-470MHz) Digital Mobile Radio with GPS function, The functions of the EUT listed as below:

	Test Standards	Reference Report
Radio	FCC Part 90	TRE1311014701
MPE	FCC Part 2.1093	TRE1311014702
MPE	FCC Part 2.1093	TRE1311014703

3. TEST ENVIRONMENT

3.1. Address of the test laboratory

Shenzhen Huatongwei International Inspection Co., Ltd
Keji Nan No.12 Road, Hi-tech Park, Shenzhen, China
Phone: 86-755-26715686 Fax: 86-755-26748089

The sites are constructed in conformance with the requirements of ANSI C63.7, ANSI C63.4 (2009) and CISPR Publication 22.

3.2. Test Facility

The test facility is recognized, certified, or accredited by the following organizations:

CNAS-Lab Code: L1225

Shenzhen Huatongwei International Inspection Co., Ltd. has been assessed and proved to be in compliance with CNAS-CL01 Accreditation Criteria for Testing and Calibration Laboratories (identical to ISO/IEC 17025: 2005 General Requirements) for the Competence of Testing and Calibration Laboratories, Date of Registration: Mar. 01, 2012. Valid time is until Feb. 28, 2015.

A2LA-Lab Cert. No. 2243.01

Shenzhen Huatongwei International Inspection Co., Ltd. EMC Laboratory has been accredited by A2LA for technical competence in the field of electrical testing, and proved to be in compliance with ISO/IEC 17025: 2005 General Requirements for the Competence of Testing and Calibration Laboratories and any additional program requirements in the identified field of testing. Valid time is until Sept. 30, 2015.

FCC-Registration No.: 662850

Shenzhen Huatongwei International Inspection Co., Ltd. EMC Laboratory has been registered and fully described in a report filed with the FCC (Federal Communications Commission). The acceptance letter from the FCC is maintained in our files. Registration 662850, Renewal date June. 01, 2012, valid time is until Jun. 01, 2015.

IC-Registration No.: 5377A

The 3m Alternate Test Site of Shenzhen Huatongwei International Inspection Co., Ltd. has been registered by Certification and Engineering Bureau of Industry Canada for the performance of radiated measurements with Registration No. 5377A on Dec. 30, 2013, valid time is until Dec. 21, 2016.

ACA

Shenzhen Huatongwei International Inspection Co., Ltd. EMC Laboratory can also perform testing for the Australian C-Tick mark as a result of our A2LA accreditation.

VCCI

The 3m Semi-anechoic chamber (12.2m×7.95m×6.7m) and Shielded Room (8m×4m×3m) of Shenzhen Huatongwei International Inspection Co., Ltd. has been registered in accordance with the Regulations for Voluntary Control Measures with Registration No.: G-292. Date of Registration: Dec. 23, 2013. Valid time is until Dec. 22, 2016.

Main Ports Conducted Interference Measurement of Shenzhen Huatongwei International Inspection Co., Ltd. has been registered in accordance with the Regulations for Voluntary Control Measures with Registration No.: C-2726. Date of Registration: Dec. 20, 2012. Valid time is until Dec. 19, 2015.

Telecommunication Ports Conducted Interference Measurement of Shenzhen Huatongwei International Inspection Co., Ltd. has been registered in accordance with the Regulations for Voluntary Control Measures with Registration No.: T-1837. Date of Registration: May 06, 2013. Valid time is until May 05, 2016.

DNV

Shenzhen Huatongwei International Inspection Co., Ltd. has been found to comply with the requirements of DNV towards subcontractor of EMC and safety testing services in conjunction with the EMC and Low voltage Directives and in the voluntary field. The acceptance is based on a formal quality Audit and follow-ups according to relevant parts of ISO/IEC Guide 17025 (2005), in accordance with the requirements of the DNV Laboratory Quality Manual towards subcontractors. Valid time is until Aug. 24, 2016.

3.3. Environmental conditions

During the measurement the environmental conditions were within the listed ranges:

Temperature:	15-35 ° C
Humidity:	30-60 %
Atmospheric pressure:	950-1050mbar

3.4. Configuration of Tested System

Fig. 2-1 Configuration of Tested System

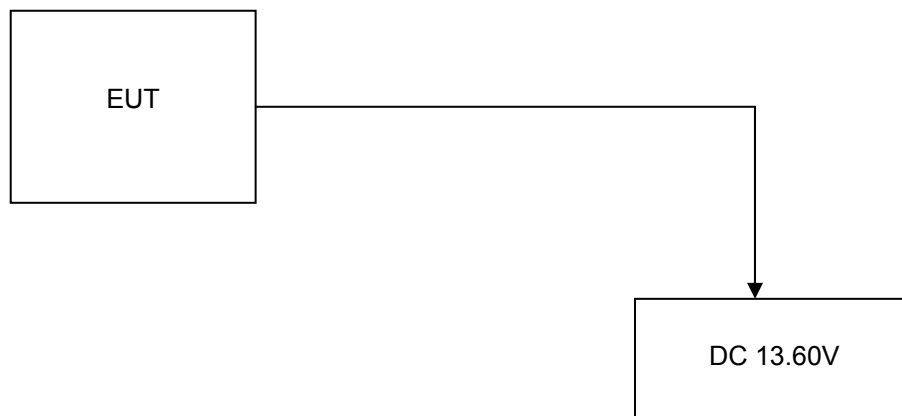

Table 2-1 Equipment Used in Tested System

3.5. Statement of the measurement uncertainty

The data and results referenced in this document are true and accurate. The reader is cautioned that there may be errors within the calibration limits of the equipment and facilities. The measurement uncertainty was calculated for all measurements listed in this test report acc. to CISPR 16 - 4 „Specification for radio disturbance and immunity measuring apparatus and methods – Part 4: Uncertainty in EMC Measurements“ and is documented in the Shenzhen Huatongwei International Inspection Co., Ltd quality system acc. to DIN EN ISO/IEC 17025. Furthermore, component and process variability of devices similar to that tested may result in additional deviation. The manufacturer has the sole responsibility of continued compliance of the device.

Hereafter the best measurement capability for Shenzhen Huatongwei laboratory is reported:

Test Items	Measurement Uncertainty	Notes
Frequency stability	25 Hz	(1)
Transmitter power conducted	0.57 dB	(1)
Transmitter power Radiated	2.20 dB	(1)
Conducted spurious emission 9KHz-40 GHz	1.60 dB	(1)
Conducted Emission 9KHz-30MHz	3.39 dB	(1)
Radiated Emission 30~1000MHz	4.65 dB	(1)
Radiated Emissio 1~18GHz	5.16 dB	(1)
Radiated Emissio 18-40GHz	5.54 dB	(1)
Occupied Bandwidth	-----	(1)
Emission Mask	-----	(1)
Modulation Characteristic	-----	(1)
Transmitter Frequency Behavior	-----	(1)

(1) This uncertainty represents an expanded uncertainty expressed at approximately the 95% confidence level using a coverage factor of k=1.96.

3.6. Test Description

Test specification clause	Test case	Verdict
FCC Part 15.107	Conducted Emission	PASS
FCC Part 90.205	Maximum Transmitter Power	PASS
FCC Part 90.207	Modulation Characteristic	PASS
FCC Part 90.209	Occupied Bandwidth	PASS
FCC Part 90.210	Emission Mask	PASS
FCC Part 90.213	Frequency Stability	PASS
FCC Part 90.214	Transmitter Frequency Behavior	PASS
FCC Part 90.210	Transmitter Radiated Spurious Emssion	PASS
FCC Part 90.210	Spurious Emssion On Antenna Port	PASS
FCC Part 15.109	Receiver Radiated Spurious Emssion	PASS
FCC Part 15.109	Receiver Conducted Spurious Emssion	PASS

Remark: 1.The measurement uncertainty is not included in the test result.

3.7. Equipments Used during the Test

AC Power Conducted Emission				
Name of Equipment	Manufacturer	Model	Serial Number	Calibration Due
Artificial Mains	Rohde&Schwarz	ESH2-Z5	100028	10/25/2014
EMI Test Receiver	Rohde&Schwarz	ESCS 30	100038	10/25/2014
Pulse Limiter	Rohde&Schwarz	ESHSZ2	100044	10/25/2014
EMI Test Software	Rohde&Schwarz	ES-K1 V1.71	N/A	N/A
RF COMMUNICATION TEST SET	HP	8920A	3813A10206	10/25/2014

DC Power Conducted Emission				
Name of Equipment	Manufacturer	Model	Serial Number	Calibration Due
Artificial Mains	Rohde&Schwarz	ESH2-Z6	100210	10/25/2014
Artificial Mains	Rohde&Schwarz	ESH2-Z6	100211	10/25/2014
EMI Test Receiver	Rohde&Schwarz	ESCS 30	100038	10/25/2014
Pulse Limiter	Rohde&Schwarz	ESHSZ2	100044	10/25/2014
EMI Test Software	Rohde&Schwarz	ES-K1 V1.71	N/A	N/A
RF COMMUNICATION TEST SET	HP	8920A	3813A10206	10/25/2014

Modulation Characteristic				
Name of Equipment	Manufacturer	Model	Serial Number	Calibration Due
RF COMMUNICATION TEST SET	HP	8920A	3813A10206	10/25/2014

Frequency Stability				
Name of Equipment	Manufacturer	Model	Serial Number	Calibration Due
RF COMMUNICATION TEST SET	HP	8920A	3813A10206	10/25/2014
Signal Generator	Rohde&Schwarz	SMT03	100059	10/25/2014
Climate Chamber	ESPEC	EL-10KA	05107008	10/25/2014

Transmitter Radiated Spurious Emission				
Name of Equipment	Manufacturer	Model	Serial Number	Calibration Due
Ultra-Broadband Antenna	Rohde&Schwarz	HL562	100015	10/25/2014
EMI Test Receiver	Rohde&Schwarz	ESI 26	100009	10/25/2014
RF Test Panel	Rohde&Schwarz	TS / RSP	335015/ 0017	N/A
HORN ANTENNA	Rohde&Schwarz	HF906	100039	10/25/2014
Turntable	ETS	2088	2149	N/A
Antenna Mast	ETS	2075	2346	N/A
EMI Test Software	Rohde&Schwarz	ES-K1 V1.71	N/A	N/A
RF COMMUNICATION TEST SET	HP	8920A	3813A10206	10/25/2014
Ultra-Broadband Antenna	ShwarzBeck	VULB9163	538	10/25/2014
Ultra-Broadband Antenna	ShwarzBeck	VULB9163	539	10/25/2014
HORN ANTENNA	ShwarzBeck	9120D	1012	10/25/2014
HORN ANTENNA	ShwarzBeck	9120D	1011	10/25/2014
TURNTABLE	MATURO	TT2.0	----	N/A
ANTENNA MAST	MATURO	TAM-4.0-P	----	N/A

Maximum Transmitter Power & Spurious Emission On Antenna Port & Occupied Bandwidth & Emission Mask				
Name of Equipment	Manufacturer	Model	Serial Number	Calibration Due
Receiver	Rohde&Schwarz	ESI 26	100009	10/25/2014
Attenuator	R&S	ESH3-22	100449	10/25/2014
RF COMMUNICATION TEST SET	HP	8920A	3813A10206	10/25/2014
High-Pass Filter	Anritsu	MP526B	6220875256	10/25/2014
High-Pass Filter	Anritsu	MP526D	6220878392	10/25/2014
Spectrum Analyzer	Aglient	E4407B	MY44210775	10/25/2014
Spectrum Analyzer	Rohde&Schwarz	FSP40	1164.4391.40	10/25/2014

Transient Frequency Behavior				
Name of Equipment	Manufacturer	Model	Serial Number	Calibration Due
Signal Generator	Rohde&Schwarz	SMT03	100059	10/25/2014
Storage Oscilloscope	Tektronix	TDS3054B	B033027	10/25/2014
RF COMMUNICATION TEST SET	HP	8920A	3813A10206	10/25/2014

The calibration interval was one year.

4. TEST CONDITIONS AND RESULTS

4.1. Conducted Emissions Test

TEST APPLICABLE

The EUT was tested according to ANSI C63.4 - 2009. The frequency spectrum from 0.15 MHz to 30 MHz was investigated. The LISN used was 50 ohm / 50 u Henry as specified by section 5.1 of ANSI C63.4 - 2009. Cables and peripherals were moved to find the maximum emission levels for each frequency.

TEST CONFIGURATION

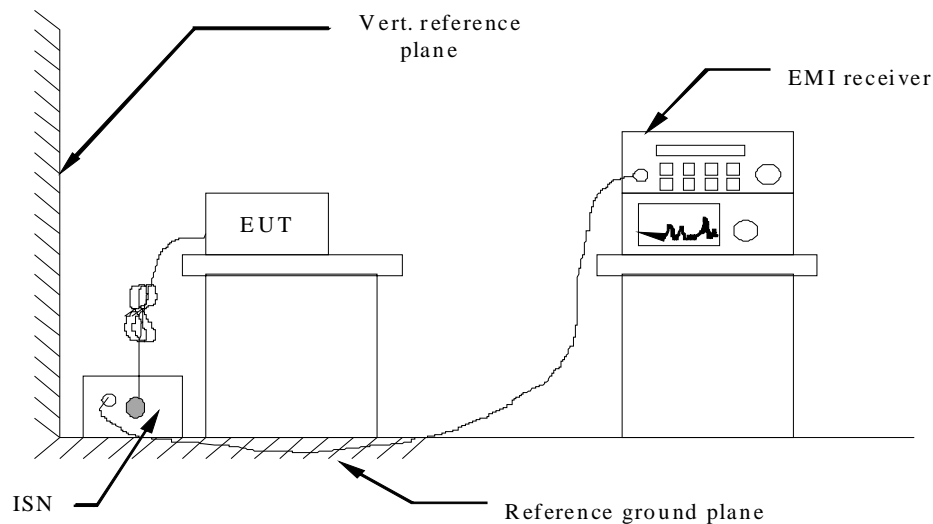

TEST PROCEDURE

- 1 The equipment was set up as per the test configuration to simulate typical actual usage per the user's manual. The EUT is a tabletop system; a wooden table with a height of 0.8 meters is used and is placed on the ground plane as per ANSI C63.4-2009.
- 2 Support equipment, if needed, was placed as per ANSI C63.4-2009.
- 3 All I/O cables were positioned to simulate typical actual usage as per ANSI C63.4-2009.
- 4 If a EUT received AC120V/60Hz power through a Line Impedance Stabilization Network (LISN) which supplied power source and was grounded to the ground plane.
- 5 If a EUT received DC 13.60V power through a Impedance Stabilization Network (ISN) which supplied power source and was grounded to the ground plane.
- 6 All support equipments received AC power from a second LISN, if any.
- 7 The EUT test program was started. Emissions were measured on each current carrying line of the EUT using a spectrum Analyzer / Receiver connected to the LISN powering the EUT. The LISN has two monitoring points: Line 1 (Hot Side) and Line 2 (Neutral Side). Two scans were taken: one with Line 1 connected to Analyzer / Receiver and Line 2 connected to a 50 ohm load; the second scan had Line 1 connected to a 50 ohm load and Line 2 connected to the Analyzer / Receiver.
- 8 Analyzer / Receiver scanned from 150 KHz to 30MHz for emissions in each of the test modes.
- 9 During the above scans, the emissions were maximized by cable manipulation.

Conducted Power Line Emission Limit

For intentional device, according to § 15.207(a) and RSS-Gen Section 7.2.4 for AC Power Conducted Emission Limits is as following:

Frequency (MHz)	Maximum RF Line Voltage (dBµV)			
	CLASS A		CLASS B	
	Q.P.	Ave.	Q.P.	Ave.
0.15 - 0.50	79	66	66-56*	56-46*
0.50 - 5.00	73	60	56	46
5.00 - 30.0	73	60	60	50

* Decreasing linearly with the logarithm of the frequency

TEST RESULTS

Remark: we tested all Op 1 to Op 6, recorded worst case at Op 1 and Op 3.

Op 1

SCAN TABLE: "Voltage (9K-30M) FIN"
 Short Description: 150K-30M Voltage

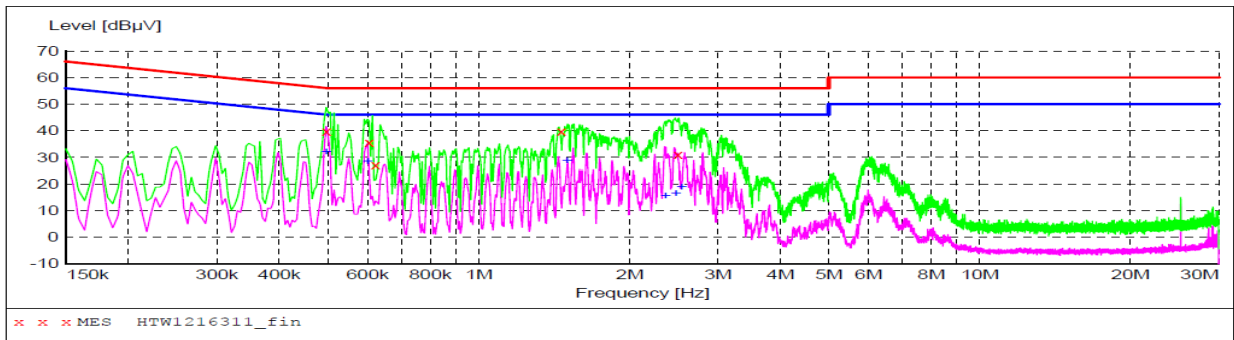

MEASUREMENT RESULT: "HTW1216311_fin"

12/16/2013 1:28PM

Frequency MHz	Level dBuV	Transd dB	Limit dBuV	Margin dB	Detector	Line	PE
0.496500	39.70	10.4	56	16.4	QP	+	GND
0.604500	35.50	10.3	56	20.5	QP	+	GND
0.622500	27.00	10.3	56	29.0	QP	+	GND
1.459500	39.90	10.3	56	16.1	QP	+	GND
2.499000	31.10	10.3	56	24.9	QP	+	GND

MEASUREMENT RESULT: "HTW1216311_fin2"

12/16/2013 1:28PM

Frequency MHz	Level dBuV	Transd dB	Limit dBuV	Margin dB	Detector	Line	PE
0.496500	32.10	10.4	46	14.0	AV	+	GND
0.600000	28.40	10.3	46	17.6	AV	+	GND
1.500000	28.70	10.3	46	17.3	AV	+	GND
2.359500	15.30	10.3	46	30.7	AV	+	GND
2.472000	16.30	10.3	46	29.7	AV	+	GND
2.539500	18.80	10.3	46	27.2	AV	+	GND

SCAN TABLE: "Voltage (9K-30M) FIN"
 Short Description: 150K-30M Voltage

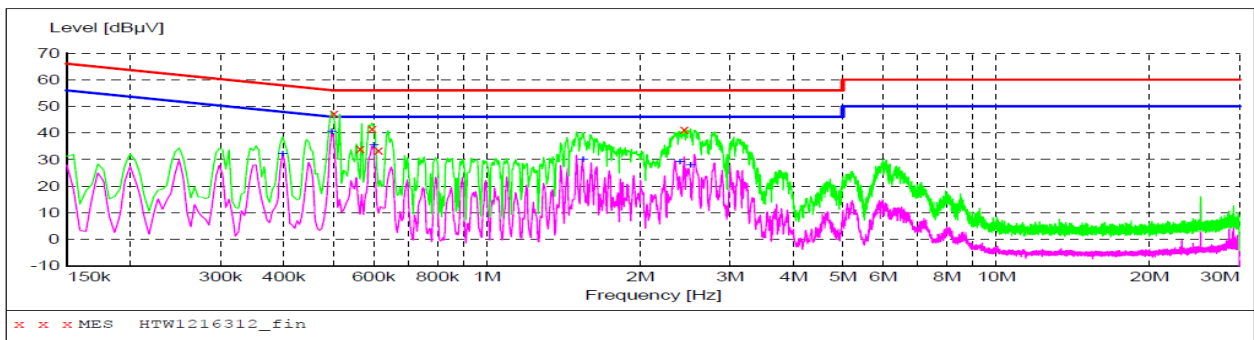

MEASUREMENT RESULT: "HTW1216312_fin"

12/16/2013 1:32PM

Frequency MHz	Level dBuV	Transd dB	Limit dBuV	Margin dB	Detector	Line	PE
0.501000	47.20	10.4	56	8.8	QP	-	GND
0.564000	34.10	10.3	56	21.9	QP	-	GND
0.595500	41.60	10.3	56	14.4	QP	-	GND
0.613500	33.50	10.3	56	22.5	QP	-	GND
2.440500	41.30	10.3	56	14.7	QP	-	GND

MEASUREMENT RESULT: "HTW1216312_fin2"

12/16/2013 1:32PM

Frequency MHz	Level dBuV	Transd dB	Limit dBuV	Margin dB	Detector	Line	PE
0.397500	31.90	10.5	48	16.0	AV	-	GND
0.496500	40.40	10.4	46	5.7	AV	-	GND
0.600000	35.30	10.3	46	10.7	AV	-	GND
1.545000	29.80	10.3	46	16.2	AV	-	GND
2.395500	29.00	10.3	46	17.0	AV	-	GND
2.512500	27.70	10.3	46	18.3	AV	-	GND

Op 3

SCAN TABLE: "Voltage (9K-30M) FIN"
 Short Description: 150K-30M Voltage

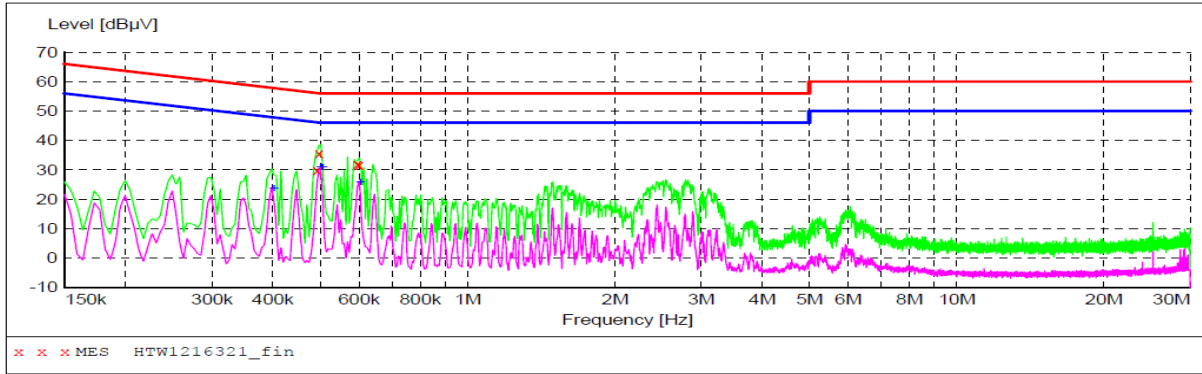

MEASUREMENT RESULT: "HTW1216321_fin"

12/16/2013 2:01PM

Frequency MHz	Level dBµV	Transd dB	Limit dBµV	Margin dB	Detector	Line	PE
0.492000	29.80	10.4	56	26.3	QP	+	GND
0.496500	35.60	10.4	56	20.5	QP	+	GND
0.595500	31.80	10.3	56	24.2	QP	+	GND
0.600000	31.70	10.3	56	24.3	QP	+	GND

MEASUREMENT RESULT: "HTW1216321_fin2"

12/16/2013 2:01PM

Frequency MHz	Level dBµV	Transd dB	Limit dBµV	Margin dB	Detector	Line	PE
0.402000	23.40	10.5	48	24.4	AV	+	GND
0.501000	30.70	10.4	46	15.3	AV	+	GND
0.505500	30.70	10.4	46	15.3	AV	+	GND
0.604500	25.60	10.3	46	20.4	AV	+	GND

SCAN TABLE: "Voltage (9K-30M) FIN"
 Short Description: 150K-30M Voltage

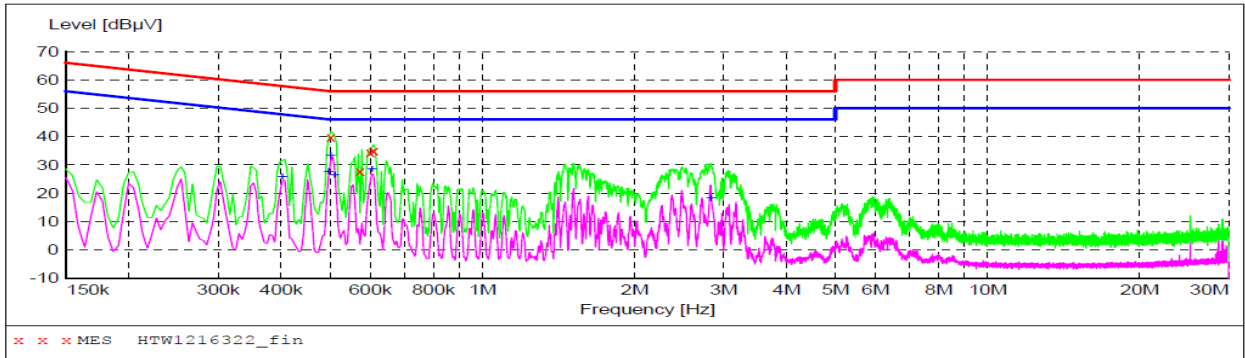

MEASUREMENT RESULT: "HTW1216322_fin"

12/16/2013 2:04PM

Frequency MHz	Level dBµV	Transd dB	Limit dBµV	Margin dB	Detector	Line	PE
0.501000	39.70	10.4	56	16.3	QP	-	GND
0.573000	27.70	10.3	56	28.3	QP	-	GND
0.600000	34.50	10.3	56	21.5	QP	-	GND
0.609000	35.10	10.3	56	20.9	QP	-	GND

MEASUREMENT RESULT: "HTW1216322_fin2"

12/16/2013 2:04PM

Frequency MHz	Level dBµV	Transd dB	Limit dBµV	Margin dB	Detector	Line	PE
0.402000	25.60	10.5	48	22.2	AV	-	GND
0.496500	27.30	10.4	46	18.8	AV	-	GND
0.501000	33.10	10.4	46	12.9	AV	-	GND
0.510000	26.20	10.4	46	19.8	AV	-	GND
0.604500	28.30	10.3	46	17.7	AV	-	GND
2.832000	18.00	10.3	46	28.0	AV	-	GND

4.2. Occupied Bandwidth and Emission Mask Test

TEST APPLICABLE

- (a). Occupied Bandwidth: The EUT was connected to the audio signal generator and the spectrum analyzer via the main RF connector, and through an appropriate attenuator. The EUT was controlled to transmit its maximum power. Then the bandwidth of 99% power can be measured by the spectrum analyzer.
- (b). Emission Mask B: For transmitters that are equipped with an audio low-pass filter pursuant to §90.211(a), the power of any emission must be below the unmodulated carrier power (P) as follows:
- (1) On any frequency removed from the assigned frequency by more than 50 percent, but not more than 100 percent of the authorized bandwidth: At least 25 dB.
 - (2) On any frequency removed from the assigned frequency by more than 100 percent, but not more than 250 percent of the authorized bandwidth: At least 35 dB.
 - (3) On any frequency removed from the assigned frequency by more than 250 percent of the authorized bandwidth: At least $43 + 10 \log (P)$ dB.
- (c). Emission Mask D, 12.5 kHz channel bandwidth equipment: For transmitters designed to operate with a 12.5 kHz channel bandwidth, any emission must be attenuated below the power (P) of the highest emission contained within the authorized bandwidth as follows:
- (1) On any frequency from the center of the authorized bandwidth f_0 to 5.625 kHz removed from f_0 : Zero dB.
 - (2) On any frequency removed from the center of the authorized bandwidth by a displacement frequency (f_d in kHz) of more than 5.625 kHz but no more than 12.5 kHz: At least $7.27(f_d - 2.88 \text{ kHz})$ dB.
 - (3) On any frequency removed from the center of the authorized bandwidth by a displacement frequency (f_d in kHz) of more than 12.5 kHz: At least $50 + 10 \log (P)$ dB or 70 dB, whichever is the lesser attenuation.

TEST CONFIGURATION

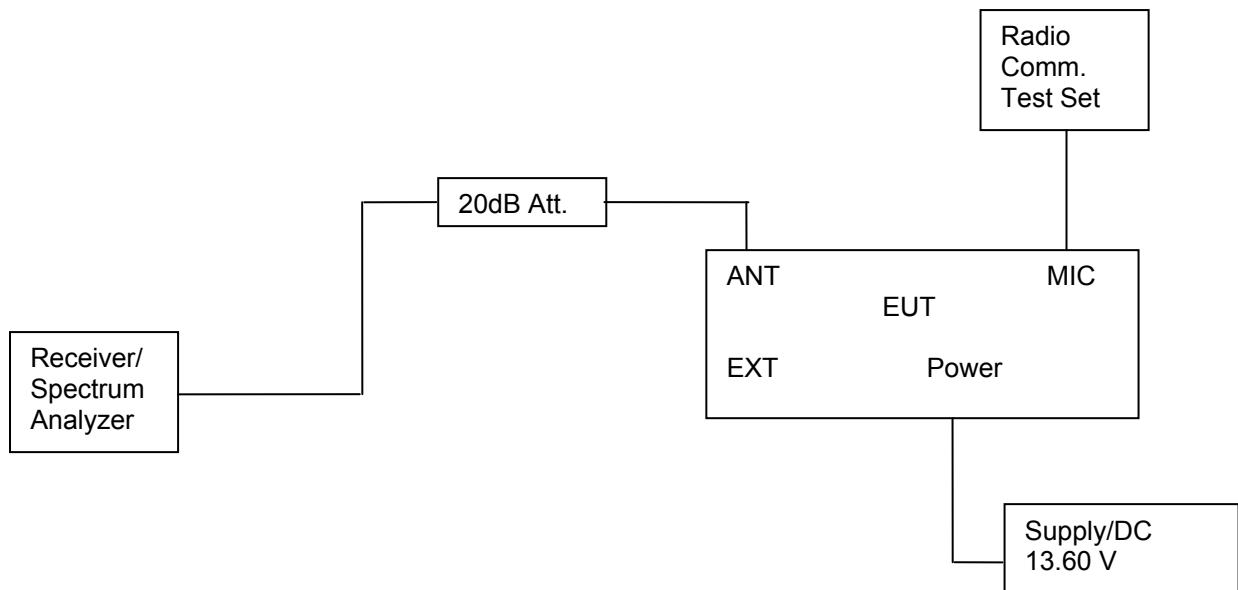

TEST PROCEDURE

- 1 The EUT was placed on a turn table which is 0.8m above ground plane.
- 2 The EUT was modulated by 2.5 KHz Sine wave audio signal; the level of the audio signal employed is 16 dB greater than that necessary to produce 50% of rated system deviation. Rated system deviation is 2.5 kHz (12.5 kHz channel spacing) and 5 kHz (25 kHz channel spacing).
- 3 Set EUT as normal operation.
- 4 Set SPA Center Frequency = fundamental frequency, RBW=300Hz, VBW= 3 KHz, span =50 KHz.
- 5 Set SPA Max hold. Mark peak, Set 99% Occupied Bandwidth and 26dB Occupied Bandwidth.
- 6 Set SPA Center Frequency=fundamental frequency, set =300Hz, VBW=1 KHz, span=50 KHz for 12.5 channel spacing.

TEST RESULTS

Remark:We tested Op 1 to Op 4,recorred worst case at Op 1,Op 3

4.2.1 Occupied Bandwidth

Modulation Type	Channel Sparation	Operation Mode	Test Channel	Test Frequency (MHz)	Occupied Bandwidth (KHz)	
					99%	26dB
Analog/FM	12.5KHz	Op 1	Ch1	406.5	9.80	1040
			Ch2	435.0	9.90	10.50
			Ch3	469.5	9.95	10.50
Digital/4FSK	12.5KHz	Op 3	Ch4	406.5	7.30	9.00
			Ch5	435.0	7.75	9.50
			Ch6	469.5	7.55	9.50
Limit			11.25KHz for 12.5KHz Channel Separation			
Test Results			PASS			

Plots of 99% and 26dB Bandwidth Measurement

Modulation Type	Channel Separation	Operation Mode	Test Channel	Test Frequency (MHz)	Occupied Bandwidth (KHz)		Limit (KHz)	Results
					99%	26dB		
FM	12.5 KHz	Op 1	Ch1	406.5	9.80	10.40	11.25	PASS

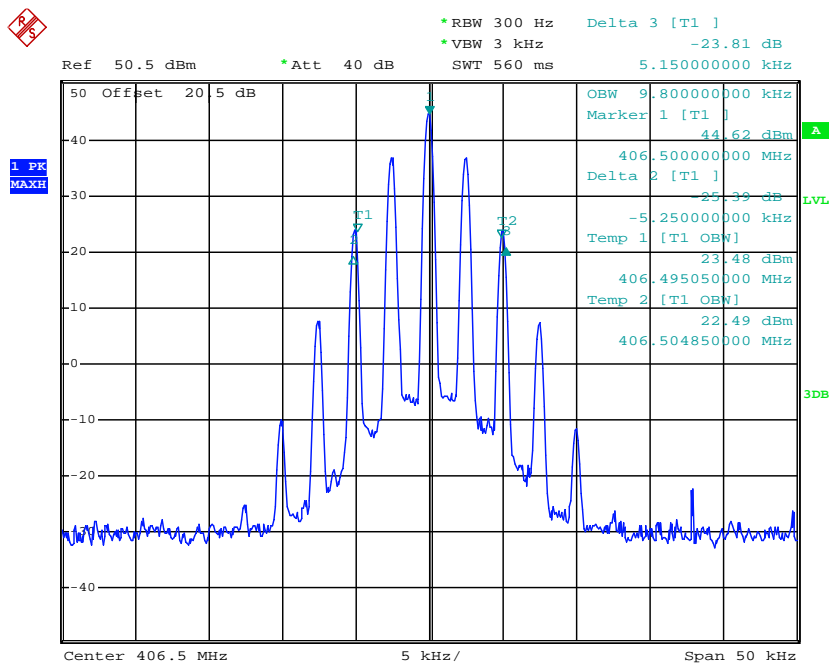

Date: 12.DEC.2013 15:37:55

Modulation Type	Channel Separation	Operation Mode	Test Channel	Test Frequency (MHz)	Occupied Bandwidth (KHz)		Limit (KHz)	Results
					99%	26dB		
FM	12.5 KHz	Op 1	Ch2	435.0	9.90	10.50	11.25	PASS

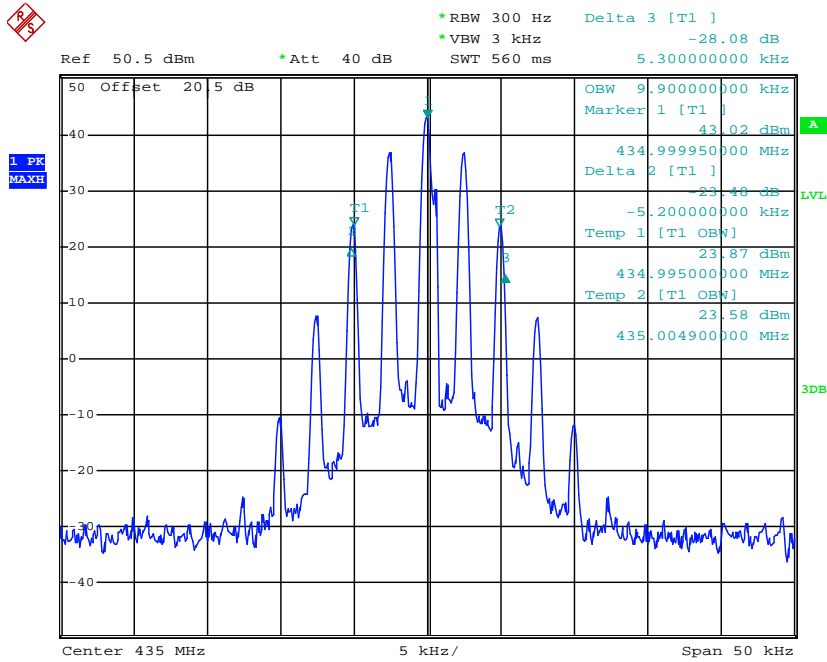

Date: 12.DEC.2013 15:51:48

Modulation Type	Channel Separation	Operation Mode	Test Channel	Test Frequency (MHz)	Occupied Bandwidth (KHz)		Limit (KHz)	Results
					99%	26dB		
FM	12.5 KHz	Op 1	Ch3	469.5	9.95	10.50	11.25	PASS

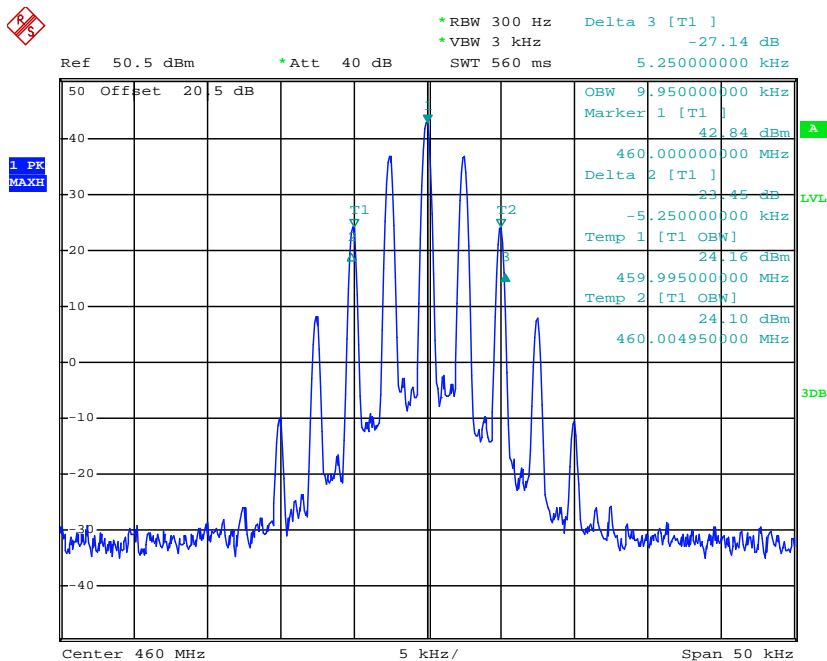

Date: 12.DEC.2013 15:54:09

Modulation Type	Channel Separation	Operation Mode	Test Channel	Test Frequency (MHz)	Occupied Bandwidth (KHz)		Limit (KHz)	Results
					99%	26dB		
4FSK	12.5 KHz	Op 3	Ch4	406.5	7.30	9.00	11.25	PASS

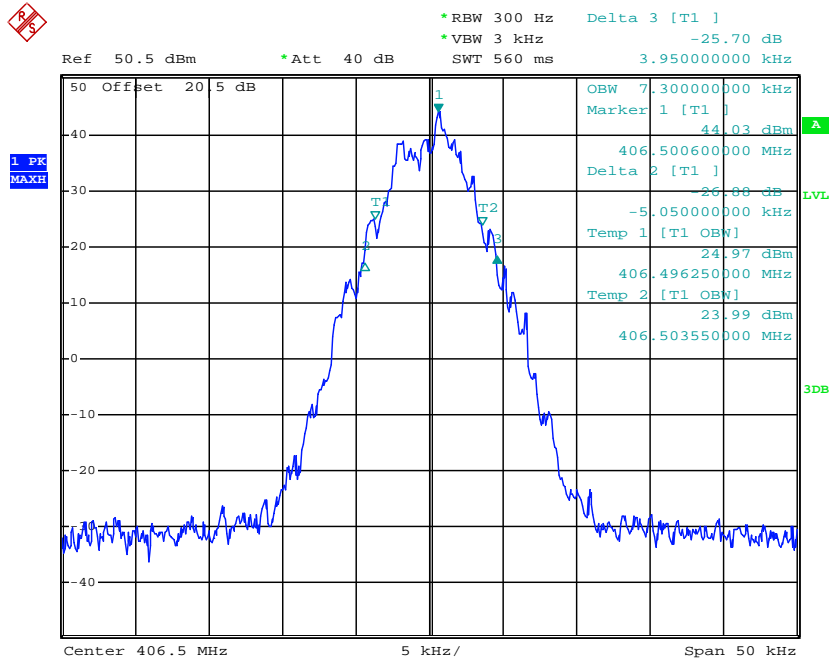

Date: 12.DEC.2013 15:19:49

Modulation Type	Channel Separation	Operation Mode	Test Channel	Test Frequency (MHz)	Occupied Bandwidth (KHz)		Limit (KHz)	Results
					99%	26dB		
4FSK	12.5 KHz	Op 3	Ch5	435.0	7.75	9.50	11.25	PASS

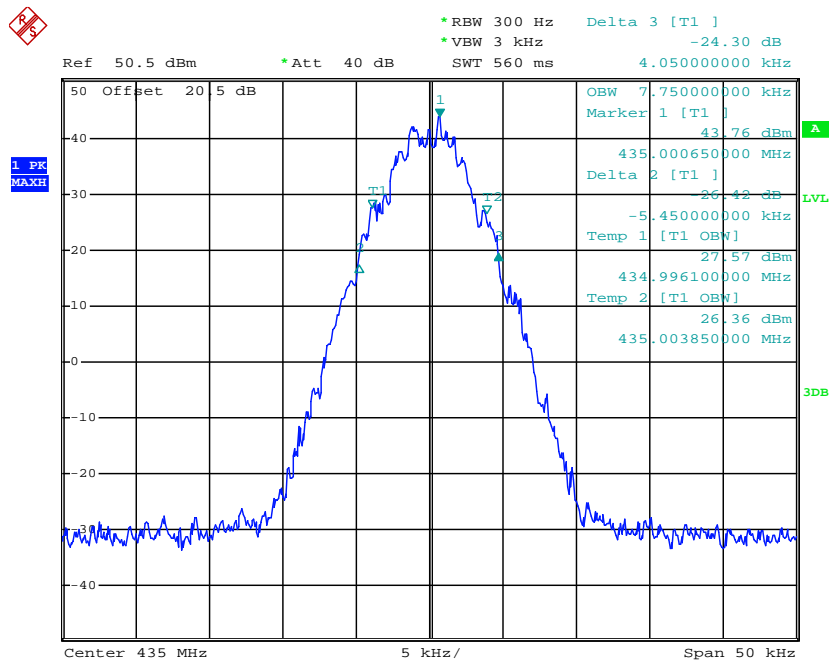

Date: 12.DEC.2013 15:29:38

Modulation Type	Channel Separation	Operation Mode	Test Channel	Test Frequency (MHz)	Occupied Bandwidth (KHz)		Limit (KHz)	Results
					99%	26dB		
4FSK	12.5 KHz	Op 3	Ch6	469.5	7.55	9.50	11.25	PASS

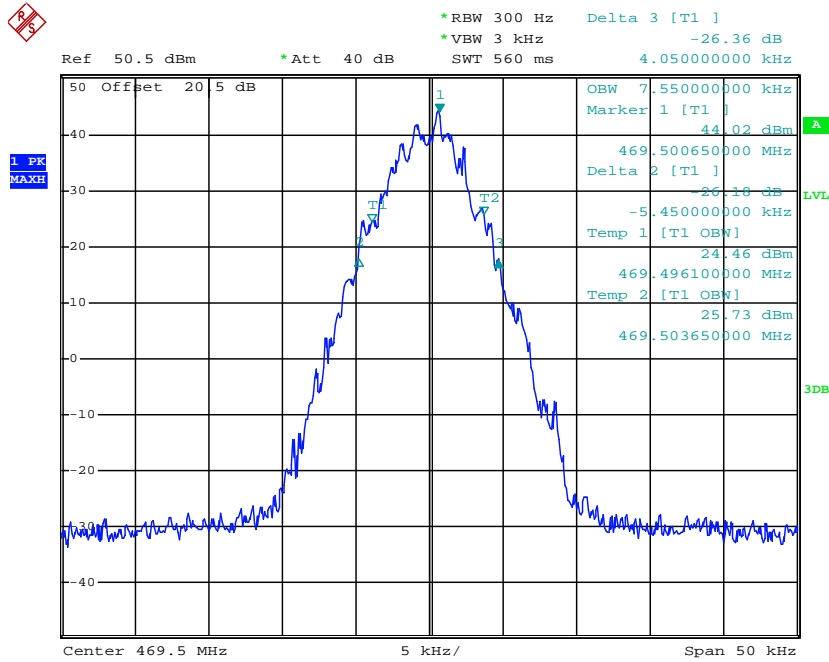

Date: 12.DEC.2013 15:35:26

4.2.2 Emission Mask

Modulation Type	Channel Separation	Operation Mode	Test Channel	Test Frequency (MHz)	Applicable Mask	RBW (Hz)
Analog/FM	12.5 KHz	Op 1	Ch1	406.5	D	300
			Ch2	435.0	D	300
			Ch3	469.5	D	300
Digital/4FSK	12.5 KHz	Op 3	Ch4	406.5	D	300
			Ch5	435.0	D	300
			Ch6	469.5	D	300
Test Results				PASS		

Plots of Emission Mask Measurement

Referred as the attached plot hereinafter
 Note: The Black curve represents unmodulated signal.
 The Blue curve represents modulated signal.

Modulation Type	Channel Separation	Operation Mode	Test Channel	Test Frequency (MHz)	Applicable Mask	RBW (Hz)	Audio Freq. (KHz)	Results
FM	12.5KHz	Op 1	Ch1	406.5	D	300	2.5	PASS

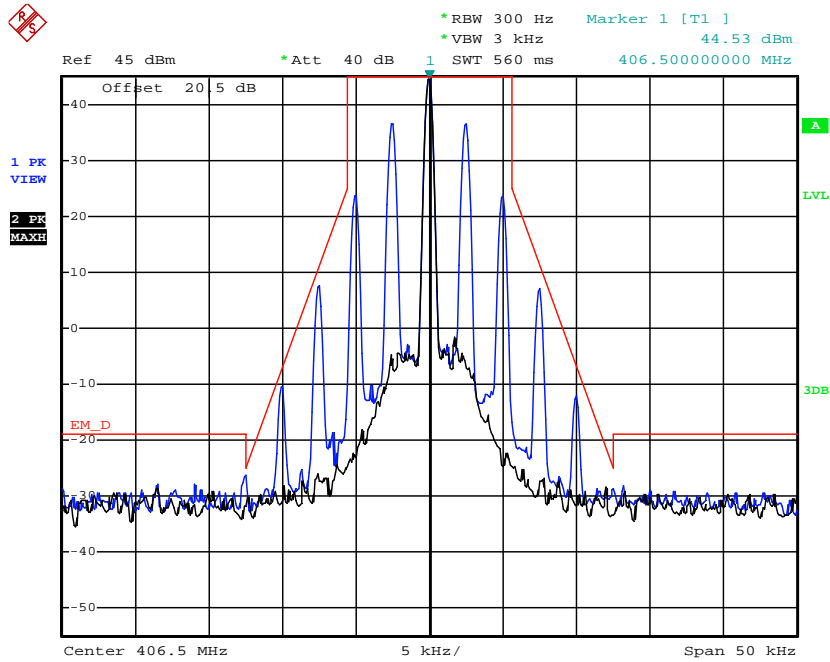

Date: 16.DEC.2013 13:57:09

Modulation Type	Channel Separation	Operation Mode	Test Channel	Test Frequency (MHz)	Applicable Mask	RBW (Hz)	Audio Freq. (KHz)	Results
FM	12.5KHz	Op 1	Ch2	435.0	D	300	2.5	PASS

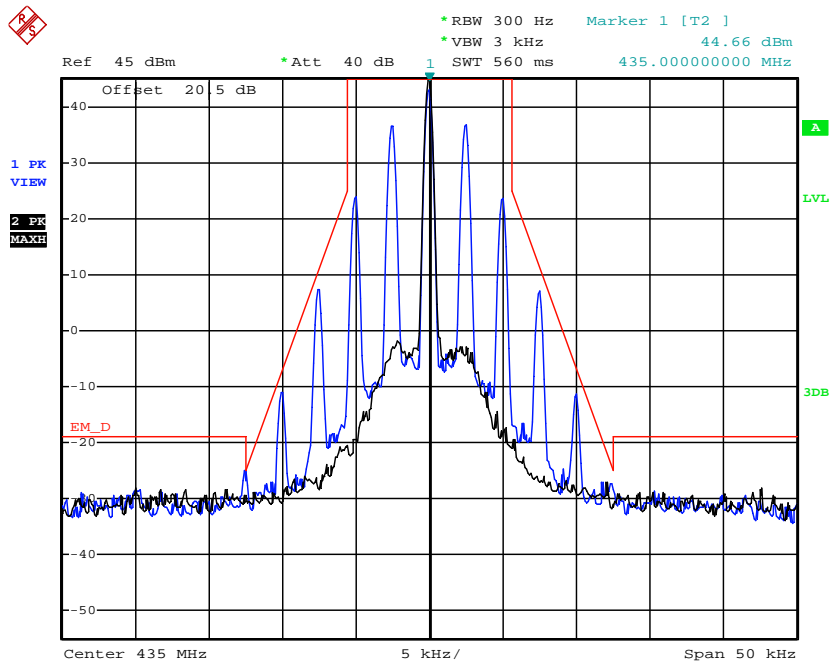

Date: 16.DEC.2013 14:03:18

Modulation Type	Channel Separation	Operation Mode	Test Channel	Test Frequency (MHz)	Applicable Mask	RBW (Hz)	Audio Freq. (KHz)	Results
FM	12.5KHz	Op 1	Ch3	469.5	D	300	2.5	PASS

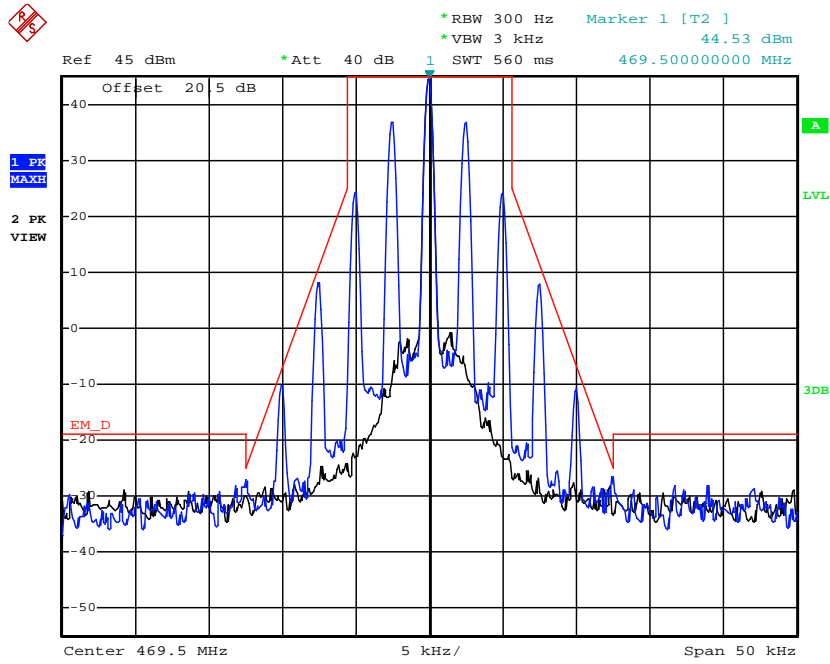

Date: 16.DEC.2013 14:05:41

Modulation Type	Channel Separation	Operation Mode	Test Channel	Test Frequency (MHz)	Applicable Mask	RBW (Hz)	Audio Freq. (KHz)	Results
4FSK	12.5KHz	Op 3	Ch1	406.5	D	300	/	PASS

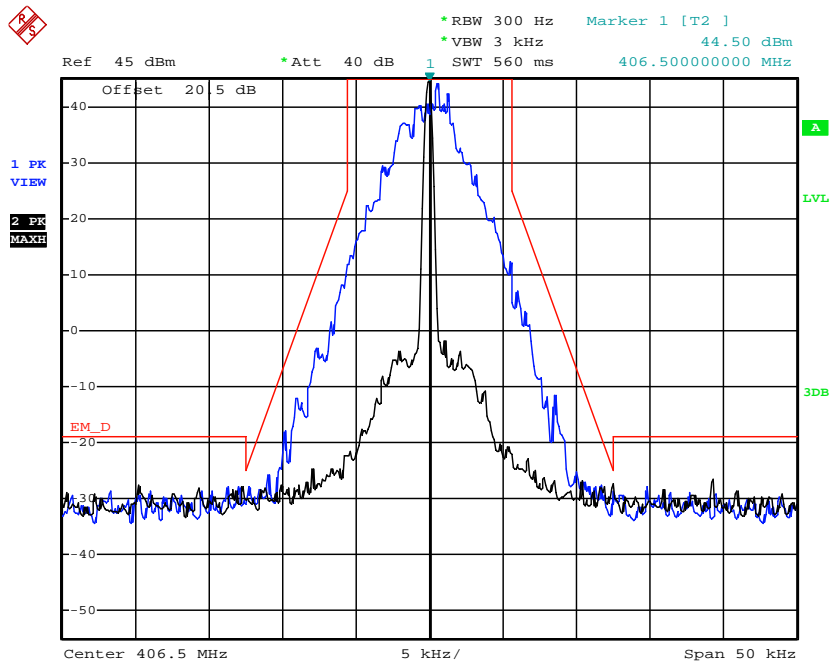

Date: 16.DEC.2013 14:16:02

Modulation Type	Channel Separation	Operation Mode	Test Channel	Test Frequency (MHz)	Applicable Mask	RBW (Hz)	Audio Freq. (KHz)	Results
4FSK	12.5KHz	Op 3	Ch2	435.0	D	300	/	PASS

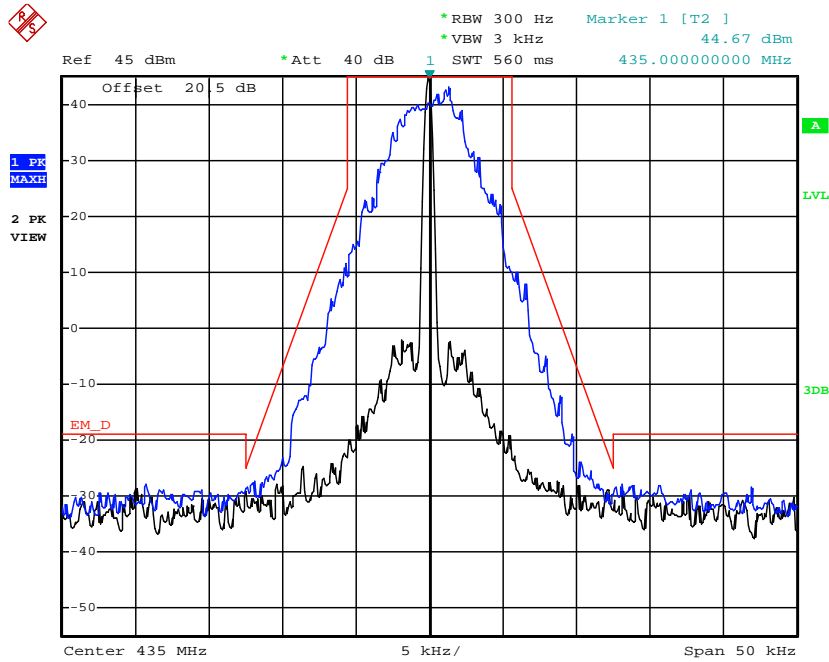

Date: 16.DEC.2013 14:19:25

Modulation Type	Channel Separation	Operation Mode	Test Channel	Test Frequency (MHz)	Applicable Mask	RBW (Hz)	Audio Freq. (KHz)	Results
4FSK	12.5KHz	Op 3	Ch3	469.5	D	300	/	PASS

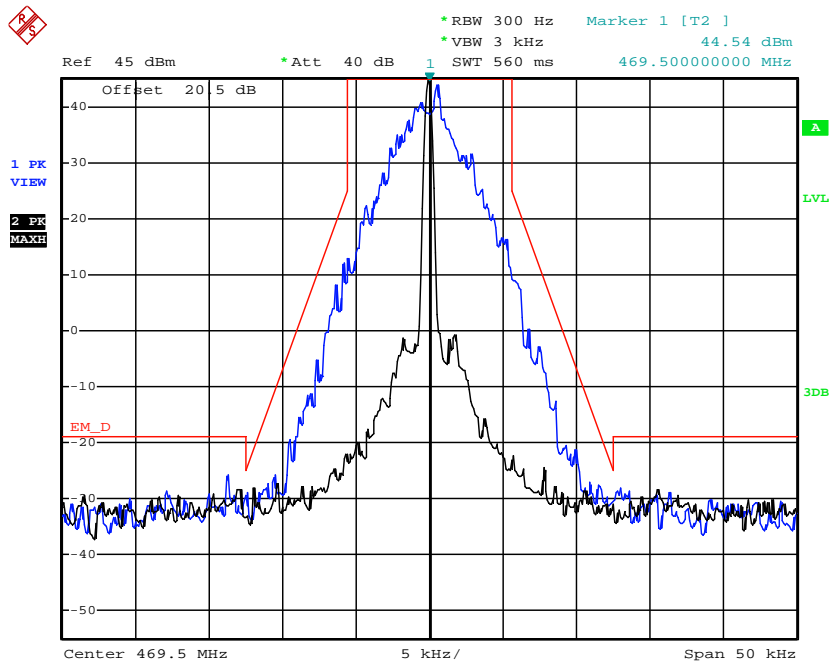

Date: 16.DEC.2013 14:22:32

4.3. Transmitter Radiated Spurious Emission

TEST APPLICABLE

According to the TIA/EIA 603 test method, and according to Section 90.210, the power of each unwanted emission shall be less than Transmitted Power as specified below for transmitters designed to operate with 12.5 KHz channel bandwidth:

- 1 On any frequency removed from the center of the authorized bandwidth f_0 to 5.625 KHz removed from f_0 : Zero dB
- 2 On any frequency removed from the center of the authorized bandwidth by a displacement frequency (f_d in KHz) f_0 of more than 5.625 KHz but no more than 12.5 KHz: At least 7.27dB
- 3 On any frequency removed from the center of the authorized bandwidth by a displacement frequency (f_d in KHz) f_0 of more than 12.5 KHz: At least $50+10 \log (P)$ dB or 70 dB, which ever is lesser attenuation.

For transmitters designed to transmit with 25 KHz channel separation and equipped with an audio low-pass filter, the power of any emission must be attenuated below the unmodulated carrier power (P) as following:

- 1 On any frequency removed from the assigned frequency by more than 50 percent, but no more than 100 percent of the authorized bandwidth: At least 25 dB.
- 2 On any frequency removed from the assigned frequency by more than 100 percent, but no more than 250 percent of the authorized bandwidth: At least 35 dB.
- 3 On any frequency removed from the assigned frequency by more than 250 percent of the authorized bandwidth: At least $43+10\text{Log} (P)$ dB.

TEST CONFIGURATION

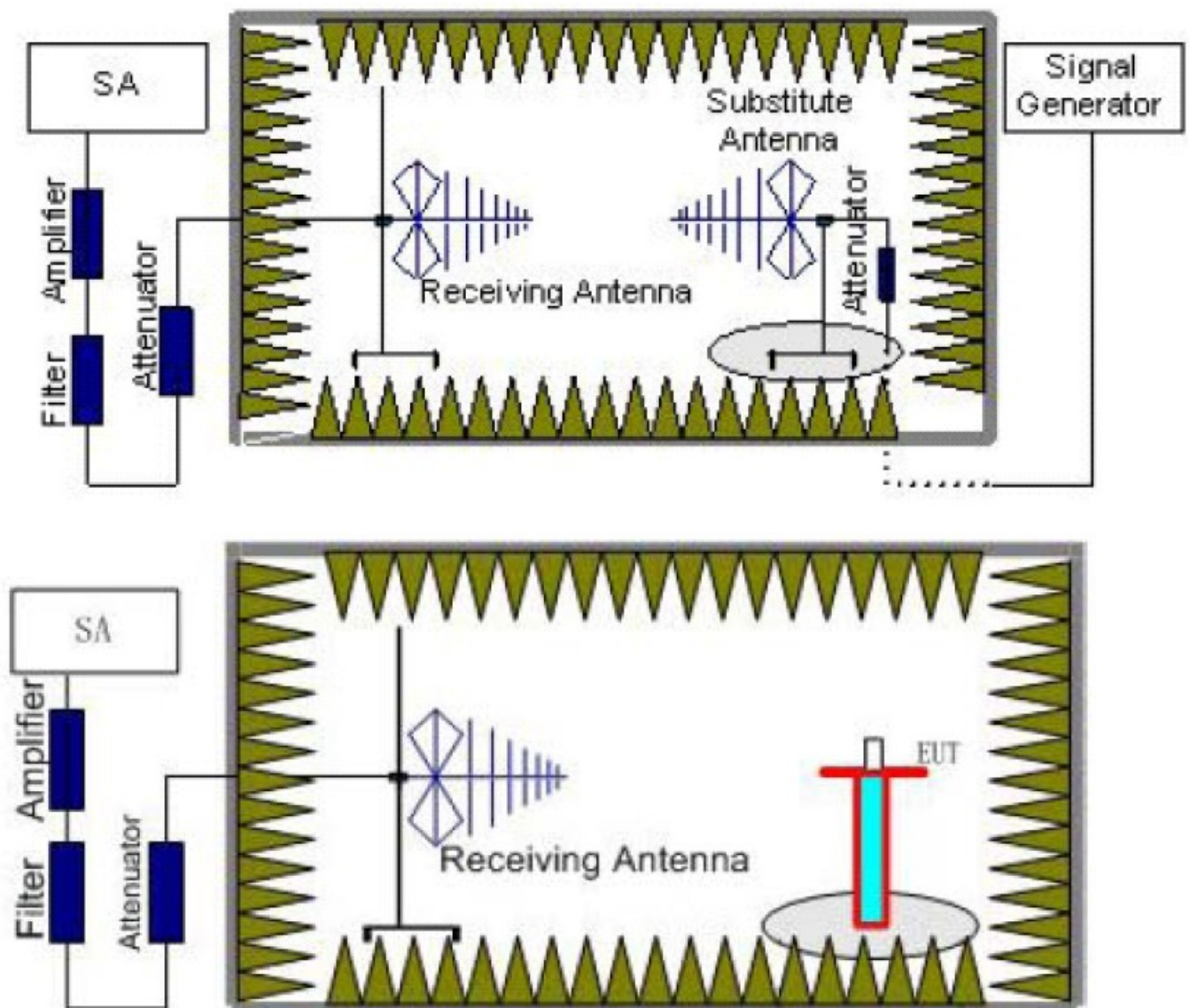

TEST PROCEDURE

1. EUT was placed on a 1.50 meter high non-conductive stand at a 3 meter test distance from the receive antenna. A receiving antenna was placed on the antenna mast 3 meters from the EUT for emission measurements. The height of receiving antenna is 1.50 m. Detected emissions were maximized at each frequency by rotating the EUT through 360° and adjusting the receiving antenna polarization. The radiated emission measurements of all transmit frequencies in six channels were measured with peak detector.
2. A log-periodic antenna or double-ridged waveguide horn antenna shall be substituted in place of the EUT. The log-periodic antenna will be driven by a signal generator and the level will be adjusted till the same power value on the spectrum analyzer or receiver. The level of the spurious emissions can be calculated through the level of the signal generator, cable loss, the gain of the substitution antenna and the reading of the spectrum analyzer or receiver.
3. The EUT is then put into continuously transmitting mode at its maximum power level during the test. Set Test Receiver or Spectrum RBW=1MHz, VBW=3MHz for above 1GHz and RBW=100KHz, VBW=300KHz for 30MHz to 1GHz, And the maximum value of the receiver should be recorded as (P_r).
4. The EUT shall be replaced by a substitution antenna. In the chamber, an substitution antenna for the frequency band of interest is placed at the reference point of the chamber. An RF Signal source for the frequency band of interest is connected to the substitution antenna with a cable that has been constructed to not interfere with the radiation pattern of the antenna. A power (P_{Mea}) is applied to the input of the substitution antenna, and adjust the level of the signal generator output until the value of the receiver reach the previously recorded (P_r). The power of signal source (P_{Mea}) is recorded. The test should be performed by rotating the test item and adjusting the receiving antenna polarization.
5. A amplifier should be connected to the Signal Source output port. And the cable should be connect between the Amplifier and the Substitution Antenna. The cable loss (P_{cl}), the Substitution Antenna Gain (G_a) and the Amplifier Gain (P_{Ag}) should be recorded after test.
The measurement results are obtained as described below:
Power(EIRP)= $P_{Mea} - P_{Ag} - P_{cl} - G_a$
We used SMF100A microwave signal generator which signal level can up to 33dBm, so we not used power Amplifier for substitution test; The measurement results are amend as described below:
Power(EIRP)= $P_{Mea} - P_{cl} - G_a$
6. This value is EIRP since the measurement is calibrated using an antenna of known gain (2.15 dBi) and known input power.
7. ERP can be calculated from EIRP by subtracting the gain of the dipole, $ERP = EIRP - 2.15dBi$.

LIMIT**Modulation Type: FM**

FCC Part 22.359, 74.462, 80.211 and 90.210 and RSS Gen, RSS 119 Issue 11 (12.5 kHz bandwidth only):
On any frequency removed from the center of the authorized bandwidth by a displacement frequency (f_d in kHz) of more than 12.5 kHz at least:

Low: $50 + 10 \log (P_{watts}) = 50 + 10 \log (28.12) = 64.49 \text{ dB}$

High: $50 + 10 \log (P_{watts}) = 50 + 10 \log (29.85) = 64.75 \text{ dB}$

Note: In general, the worse case attenuation requirement shown above was applied.

Calculation: Limit (dBm) = $EL - 50 - 10 \log_{10} (TP)$

Notes: EL is the emission level of the Output Power expressed in dBm,

In this application, the EL is 43.98 dBm.

Limit (dBm) = $43.98 - 50 - 10 \log_{10} (29.85) = -20 \text{ dBm}$

Modulation Type: 4FSK

FCC Part 22.359, 74.462, 80.211 and 90.210 and RSS Gen, RSS 119 Issue 11 (12.5 kHz Bandwidth only):
On any frequency removed from the center of the authorized bandwidth by a displacement frequency (f_d in kHz) of more than 12.5 kHz at least:

Low: $50 + 10 \log (P_{watts}) = 50 + 10 \log (28.58) = 54.56 \text{ dB}$

High: $50 + 10 \log (P_{watts}) = 50 + 10 \log (29.85) = 64.75 \text{ dB}$

Note: In general, the worse case attenuation requirement shown above was applied.

Calculation: Limit (dBm) = $EL - 50 - 10 \log_{10} (TP)$

Notes: EL is the emission level of the Output Power expressed in dBm,

In this application, the EL is 43.98 dBm.

Limit (dBm) = $43.98 - 50 - 10 \log_{10} (29.85) = -20 \text{ dBm}$

Note: 1. In general, the worse case attenuation requirement shown above was applied.

2. The measurement frequency range from 30 MHz to 5 GHz.

3. *** means that the emission level is too low to be measured or at least 20 dB down than the limit.

4.4. Spurious Emission on Antenna Port

TEST APPLICABLE

The same as Section 4.3

TEST PROCEDURE

The RF output of the EUT was connected to a spectrum analyzer through appropriate attenuation. The resolution bandwidth of the spectrum analyzer was set to 100 kHz. Sufficient scans were taken to show any out of band emission up to 10th. Harmonic for the lower and the highest frequency range. Set RBW 100 kHz, VBW 300 kHz in the frequency band 30MHz to 1GHz, while set RBW=1MHz, VBW=3MHz from the 1GHz to 10th Harmonic.

The audio input was set to 0 to get the unmodulated carrier, the resulting picture is print out for each channel separation.

TEST CONFIGURATION

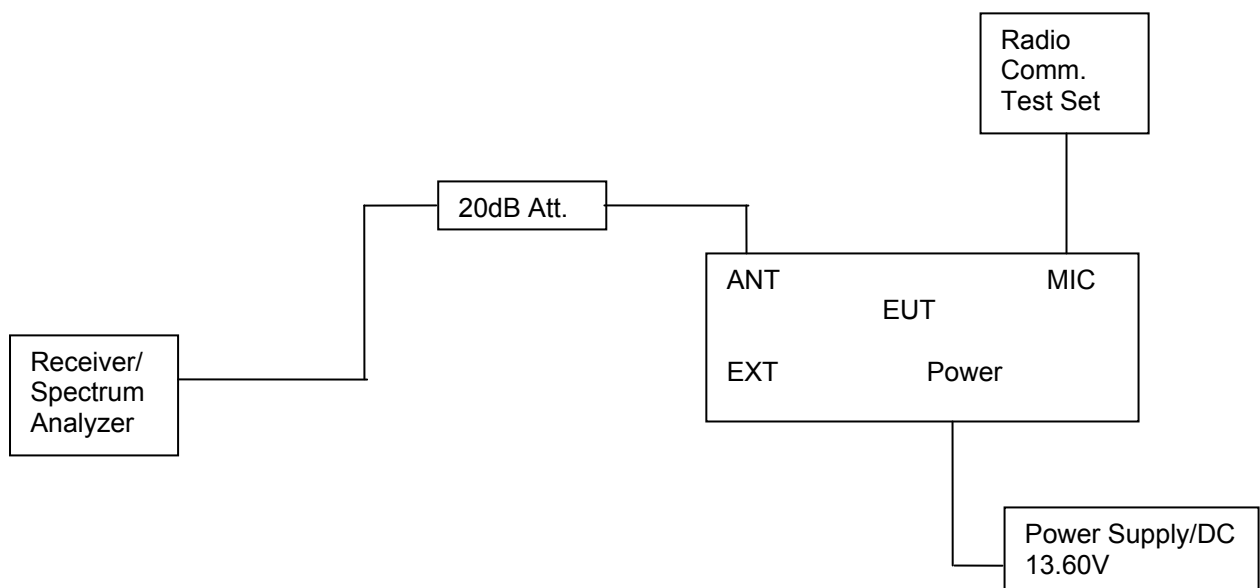

LIMIT

Modulation Type: FM

FCC Part 22.359, 74.462, 80.211 and 90.211 and RSS Gen, RSS 119 Issue 11 (12.5 kHz bandwidth only):
On any frequency removed from the center of the authorized bandwidth by a displacement frequency (f_d in kHz) of more than 12.5 kHz at least:

Low: $50 + 10 \log (P_{\text{watts}}) = 50 + 10 \log (28.12) = 64.49 \text{ dB}$

High: $50 + 10 \log (P_{\text{watts}}) = 50 + 10 \log (29.85) = 64.75 \text{ dB}$

Note: In general, the worse case attenuation requirement shown above was applied.

Calculation: Limit (dBm) = EL - 50 - 10log₁₀ (TP)

Notes: EL is the emission level of the Output Power expressed in dBm,

In this application, the EL is 43.98 dBm.

Limit (dBm) = 43.98 - 50 - 10log₁₀ (29.85) = -20 dBm

Modulation Type: 4FSK

FCC Part 22.359, 74.462, 80.211 and 90.211 and RSS Gen, RSS 119 Issue 11 (12.5 kHz Bandwidth only):
On any frequency removed from the center of the authorized bandwidth by a displacement frequency (f_d in kHz) of more than 12.5 kHz at least:

Low: $50 + 10 \log (P_{\text{watts}}) = 50 + 10 \log (28.58) = 54.56 \text{ dB}$

High: $50 + 10 \log (P_{\text{watts}}) = 50 + 10 \log (29.85) = 64.75 \text{ dB}$

Note: In general, the worse case attenuation requirement shown above was applied.

Calculation: Limit (dBm) = EL - 50 - 10log₁₀ (TP)

Notes: EL is the emission level of the Output Power expressed in dBm,

In this application, the EL is 43.98 dBm.
 Limit (dBm) = 43.98 - 50 - 10log10 (29.85) = -20 dBm

Note: 1. In general, the worse case attenuation requirement shown above was applied.
 2. The measurement frequency range from 30 MHz to 5GHz.

TEST RESULTS

Operation Mode	Test Channel	Test Frequency (MHz)	Maximum Conducted Spurious Emissions Below 1GHz		Maximum Conducted Spurious Emissions Above 1GHz	
			Frequency (MHz)	Datum (dBm)	Frequency (MHz)	Datum (dBm)
Op 1	Ch1	406.5	226.46	-23.27	3584.00	-44.58
	Ch2	435.0	355.15	-24.24	3584.00	-44.12
	Ch3	469.5	255.15	-23.32	3696.00	-44.87
Op 2	Ch1	406.5	250.20	-23.25	3112.00	-44.98
	Ch2	435.0	125.36	-23.57	3128.00	-44.60
	Ch3	469.5	103.67	-24.25	3184.00	-44.82
Op 3	Ch4	406.5	436.38	-24.05	3272.00	-43.53
	Ch5	435.0	268.17	-24.35	3264.00	-44.58
	Ch6	469.5	138.56	-23.47	3160.00	-44.64
Op 4	Ch4	406.5	273.57	-23.67	3304.00	-44.78
	Ch5	435.0	235.67	-24.38	3176.00	-44.95
	Ch6	469.5	378.51	-23.81	3160.00	-44.08
Limit			-20dBm for 12.5KHz Channel Separation			
Test Results			PASS			

Plots of Spurious Emission on Antenna Port Measurement

Operation Mode	Test Channel	Test Frequency (MHz)	Maximum Conducted Spurious Emissions Below 1GHz		Maximum Conducted Spurious Emissions Above 1GHz		Limit (dBm)
			Frequency (MHz)	Datum (dBm)	Frequency (MHz)	Datum (dBm)	
Op 1	Ch1	406.5	226.46	-23.27	3584.00	-44.58	-20.00

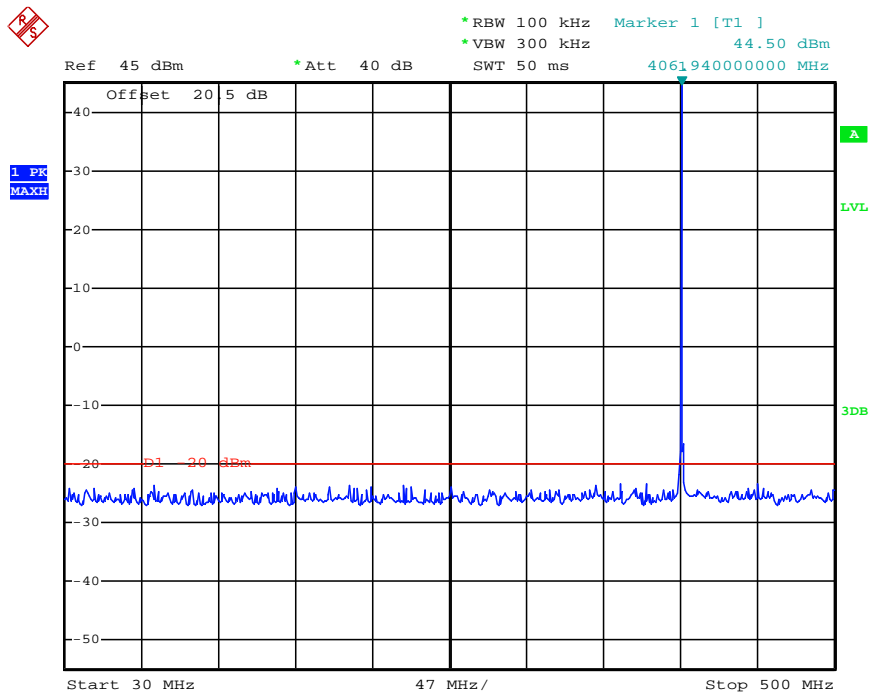



*RBW 100 kHz Marker 1 [T1]
*VBW 300 kHz -48.18 dBm
SWT 50 ms 926.00000000 MHz

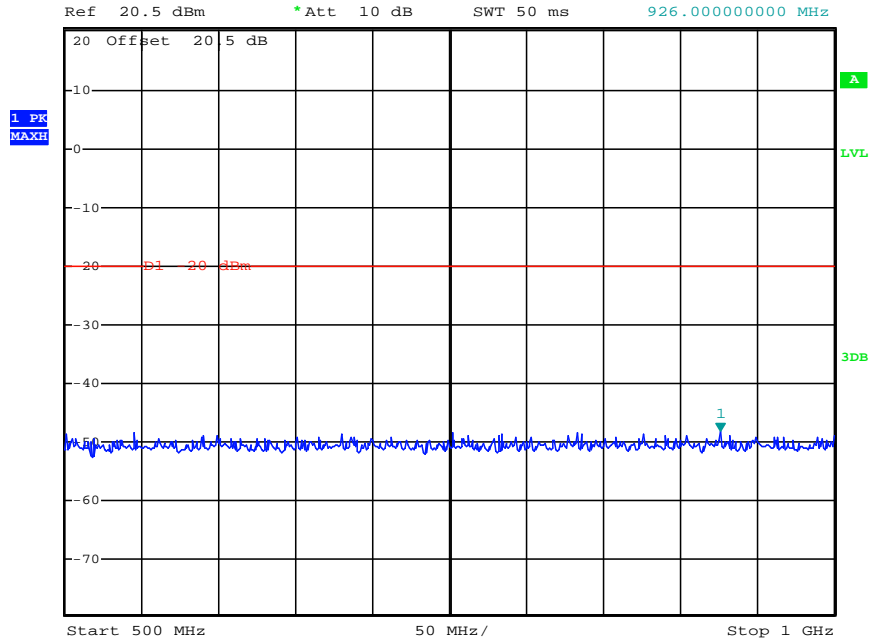

Date: 16.DEC.2013 14:52:15



*RBW 1 MHz Marker 2 [T1]
*VBW 3 MHz -46.66 dBm
SWT 80 ms 1.216000000 GHz

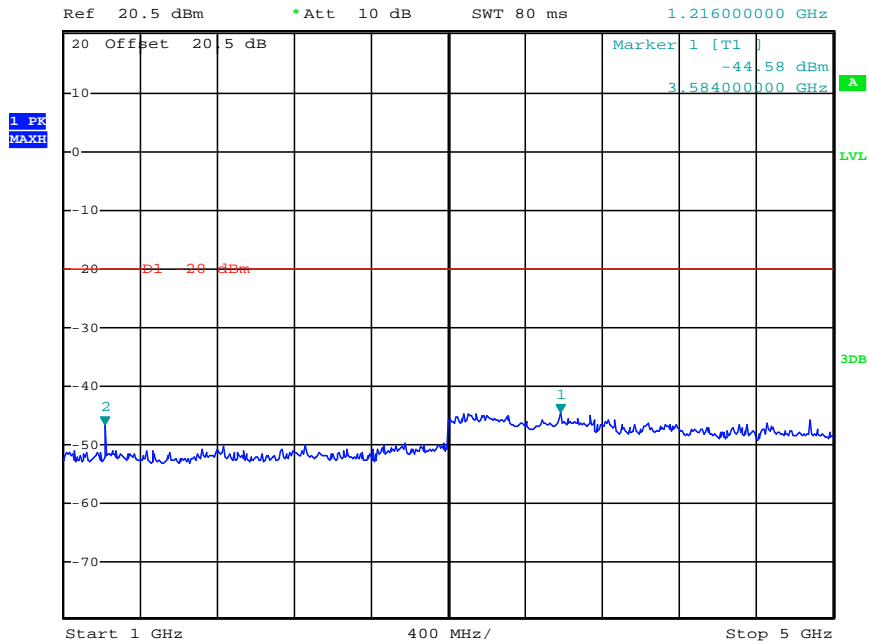

Date: 16.DEC.2013 14:52:47

Operation Mode	Test Channel	Test Frequency (MHz)	Maximum Conducted Spurious Emissions Below 1GHz		Maximum Conducted Spurious Emissions Above 1GHz		Limit (dBm)
			Frequency (MHz)	Datum (dBm)	Frequency (MHz)	Datum (dBm)	
Op 1	Ch2	435.0	355.15	-24.24	3584.00	-44.12	-20.00

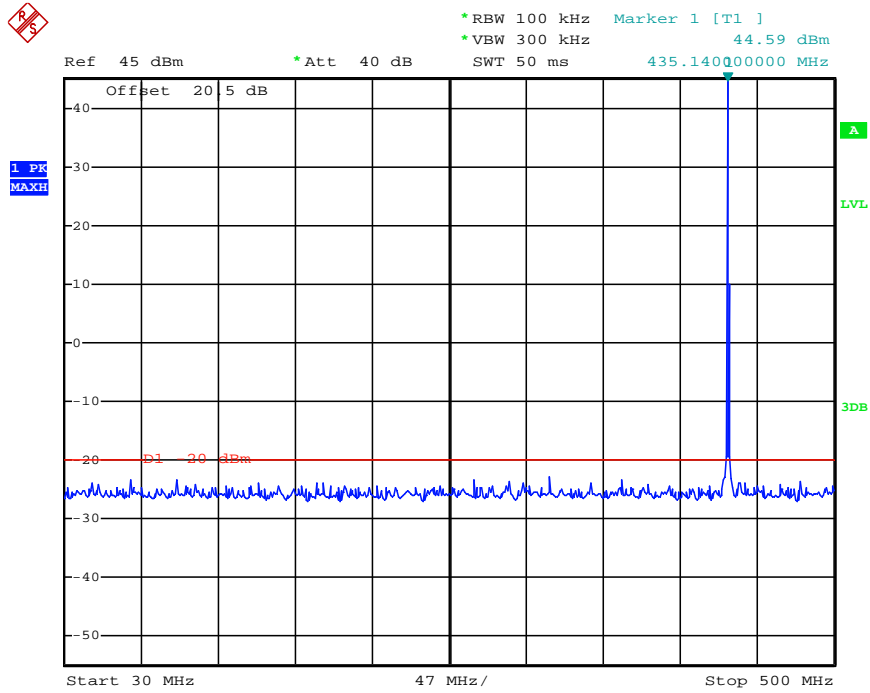

Date: 16.DEC.2013 14:29:20

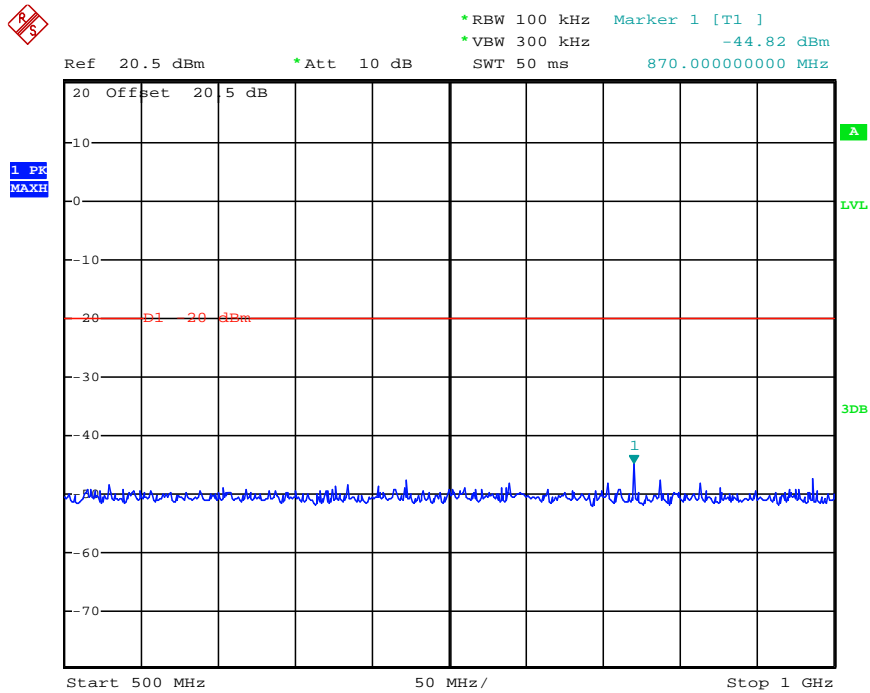

Date: 16.DEC.2013 14:58:22

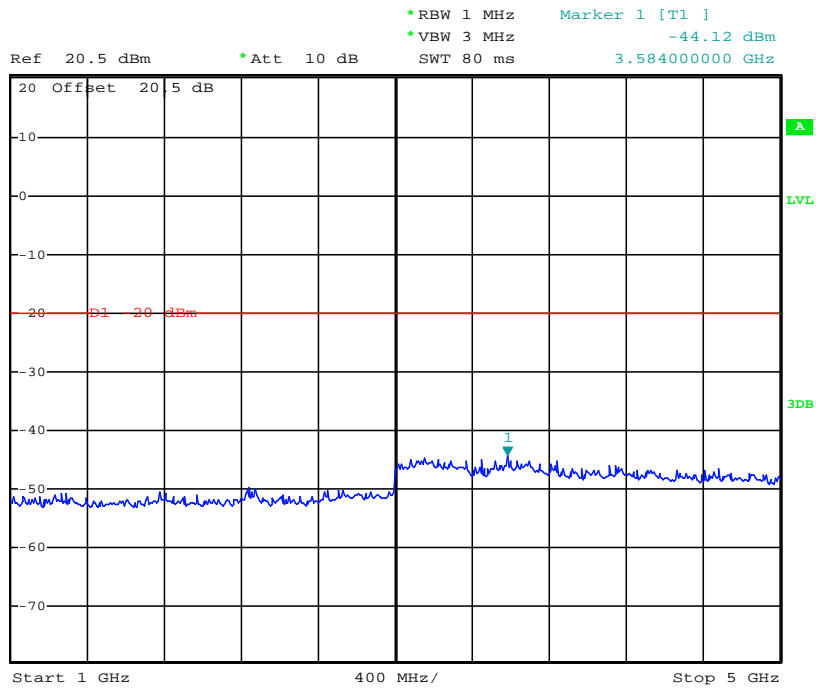

Date: 16.DEC.2013 15:01:05

Operation Mode	Test Channel	Test Frequency (MHz)	Maximum Conducted Spurious Emissions Below 1GHz		Maximum Conducted Spurious Emissions Above 1GHz		Limit (dBm)
			Frequency (MHz)	Datum (dBm)	Frequency (MHz)	Datum (dBm)	
Op 1	Ch3	469.5	255.15	-23.32	3696.00	-44.87	-20.00

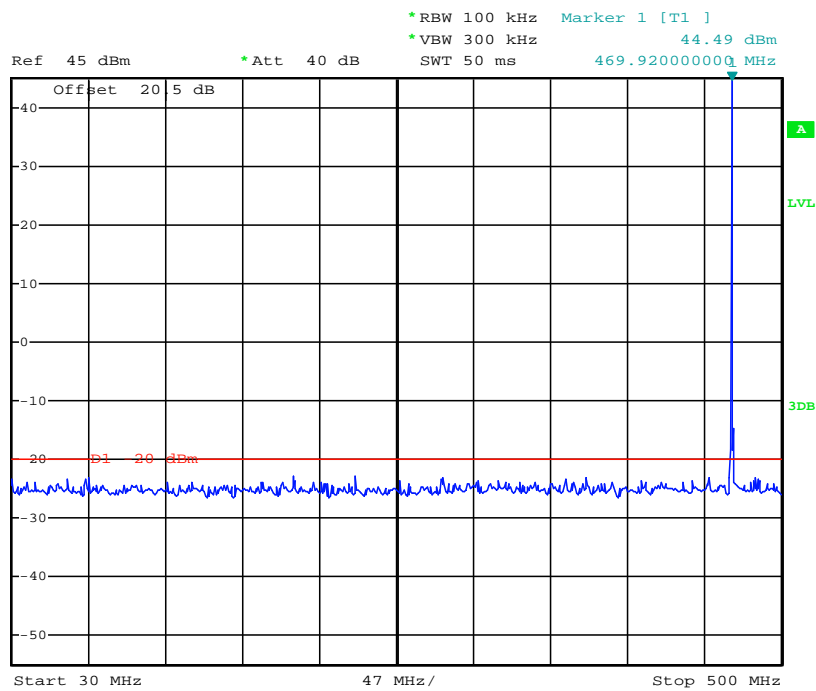

Date: 16.DEC.2013 14:30:48



*RBW 100 kHz Marker 1 [T1]
*VBW 300 kHz -42.06 dBm
SWT 50 ms 939.00000000 MHz

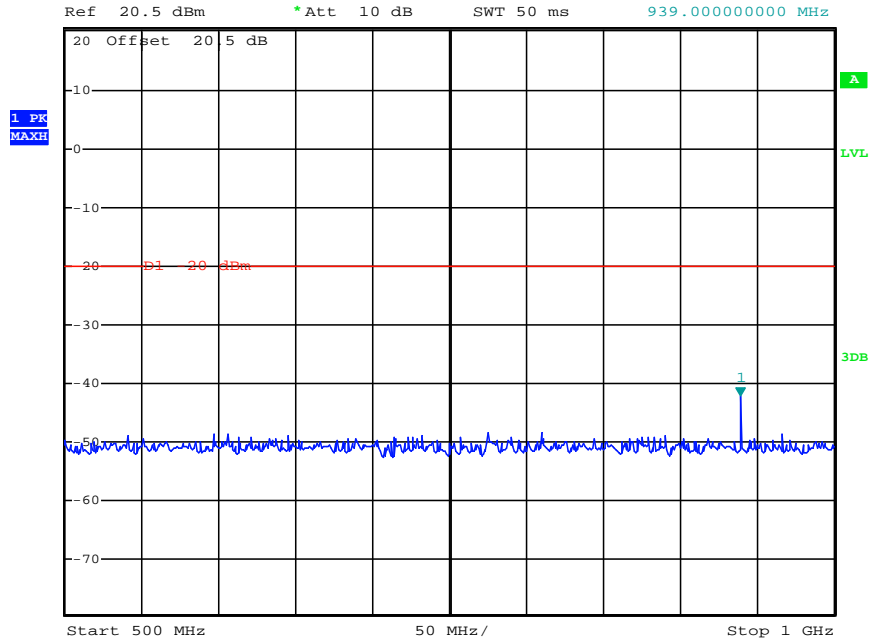

Date: 16.DEC.2013 14:59:14



*RBW 1 MHz Marker 1 [T1]
*VBW 3 MHz -44.87 dBm
SWT 80 ms 3.696000000 GHz

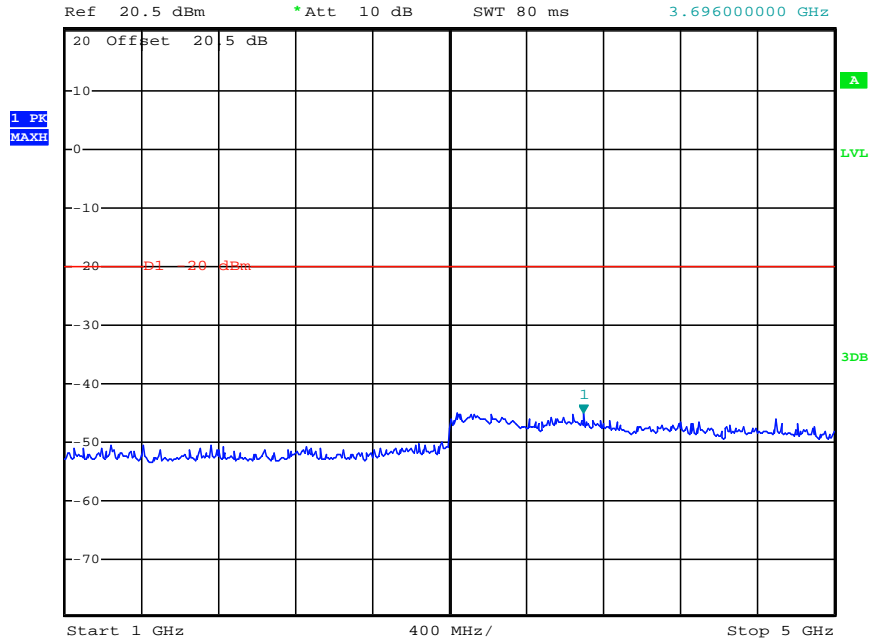

Date: 16.DEC.2013 14:59:36

Operation Mode	Test Channel	Test Frequency (MHz)	Maximum Conducted Spurious Emissions Below 1GHz		Maximum Conducted Spurious Emissions Above 1GHz		Limit (dBm)
			Frequency (MHz)	Datum (dBm)	Frequency (MHz)	Datum (dBm)	
Op 2	Ch1	406.5	250.20	-23.25	3112.00	-44.98	-20.00

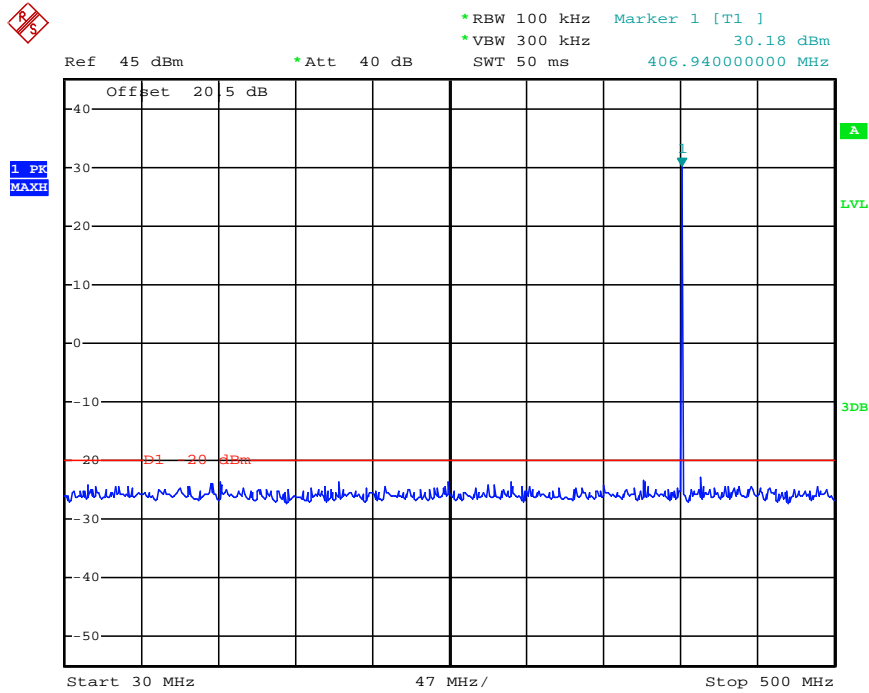

Date: 16.DEC.2013 14:31:50

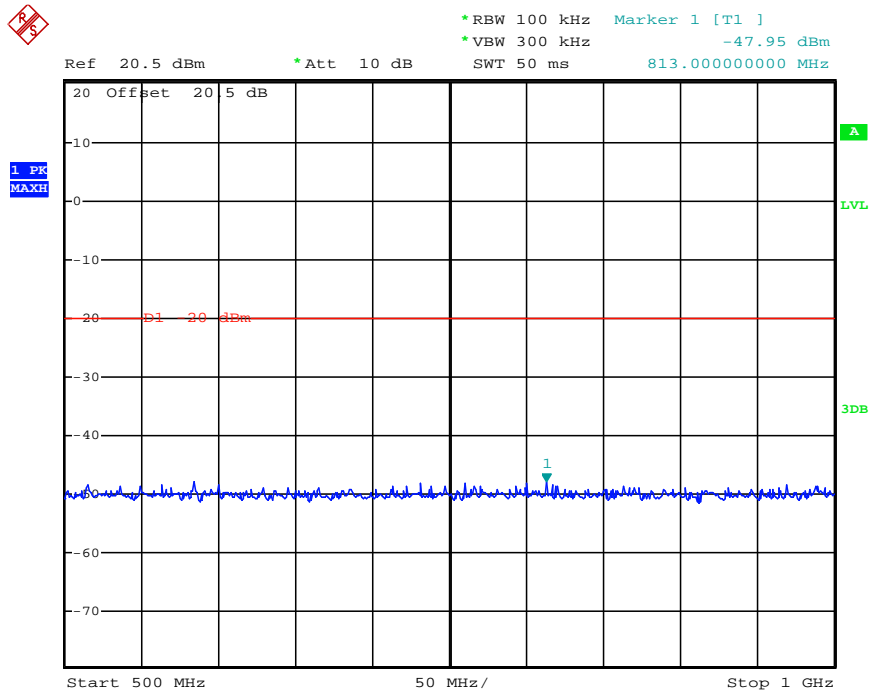

Date: 16.DEC.2013 15:03:28

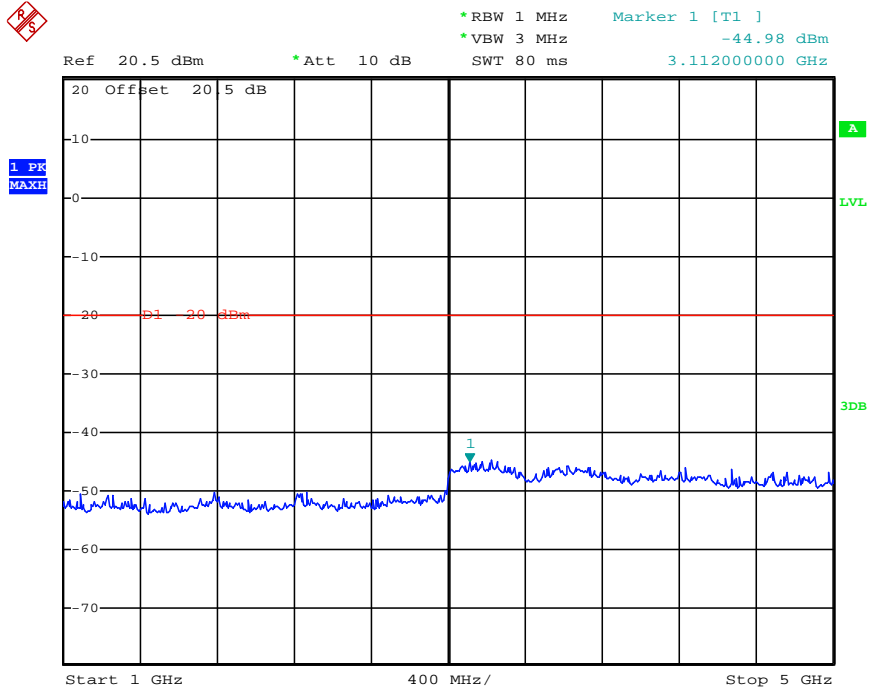

Date: 16.DEC.2013 15:07:32

Operation Mode	Test Channel	Test Frequency (MHz)	Maximum Conducted Spurious Emissions Below 1GHz		Maximum Conducted Spurious Emissions Above 1GHz		Limit (dBm)
			Frequency (MHz)	Datum (dBm)	Frequency (MHz)	Datum (dBm)	
Op 2	Ch2	435.0	125.36	-23.57	3128.00	-44.60	-20.00

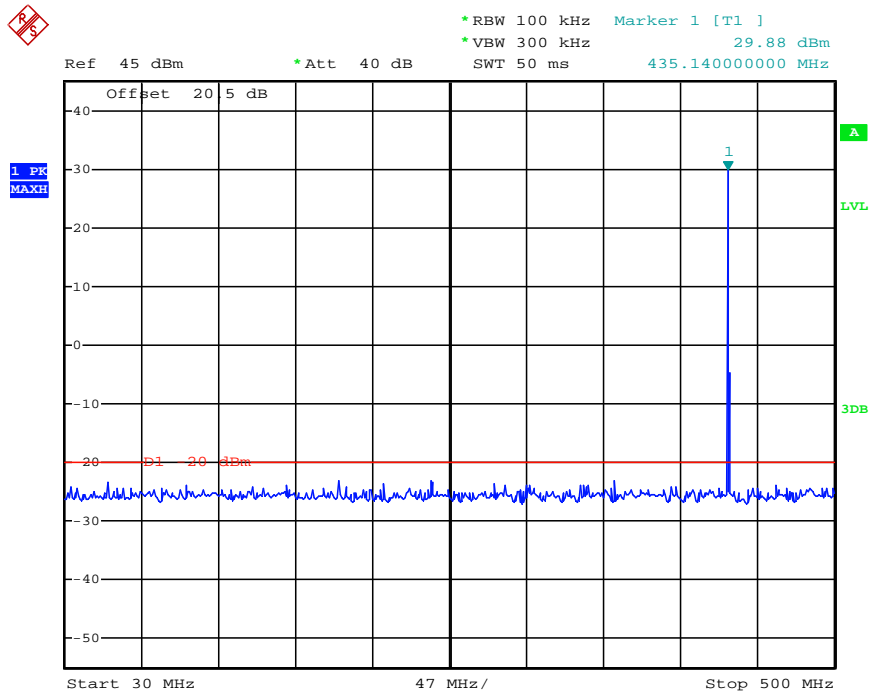

Date: 16.DEC.2013 14:32:50



*RBW 100 kHz Marker 1 [T1]
*VBW 300 kHz -47.71 dBm
SWT 50 ms 837.00000000 MHz

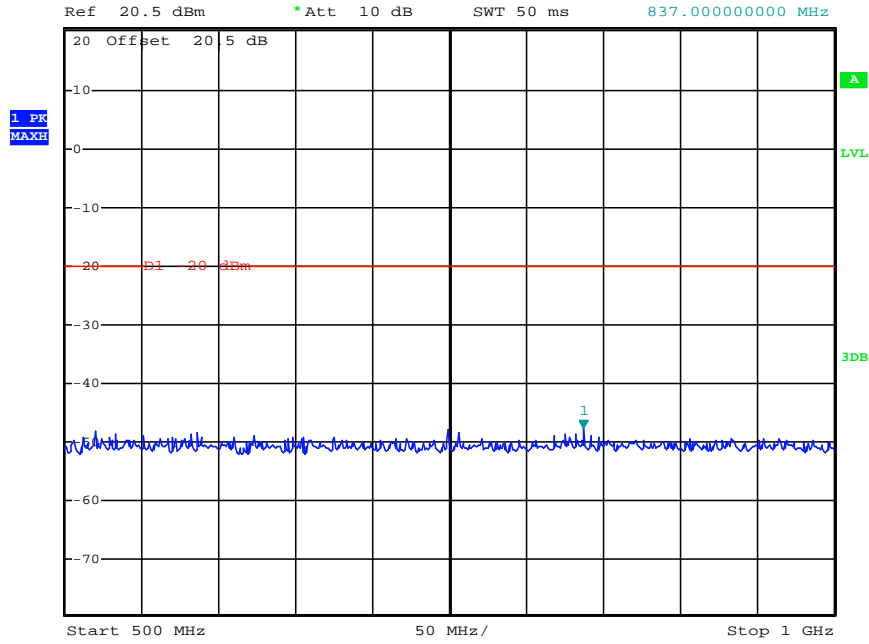

Date: 16.DEC.2013 15:04:21



*RBW 1 MHz Marker 1 [T1]
*VBW 3 MHz -44.60 dBm
SWT 80 ms 3.128000000 GHz

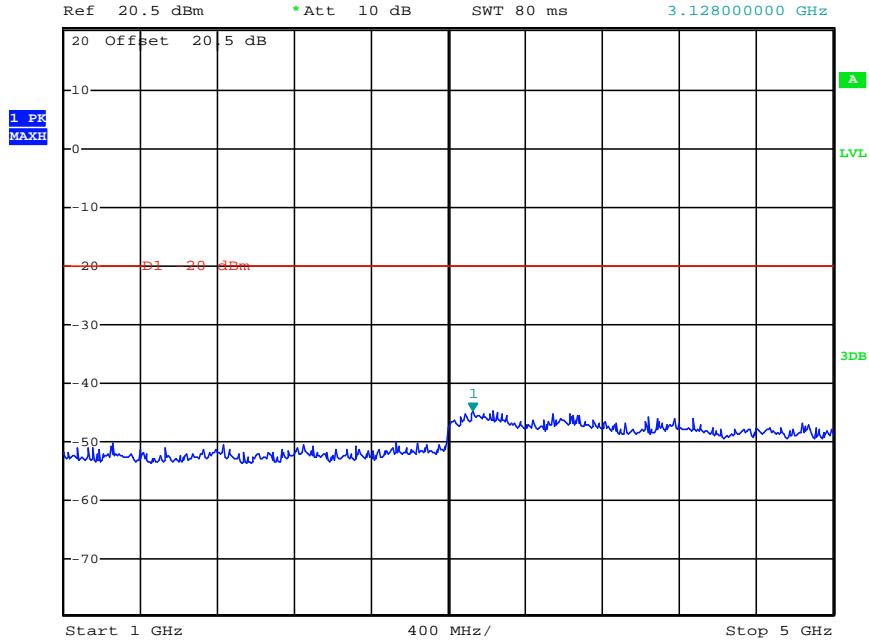

Date: 16.DEC.2013 15:06:35

Operation Mode	Test Channel	Test Frequency (MHz)	Maximum Conducted Spurious Emissions Below 1GHz		Maximum Conducted Spurious Emissions Above 1GHz		Limit (dBm)
			Frequency (MHz)	Datum (dBm)	Frequency (MHz)	Datum (dBm)	
Op 2	Ch3	469.5	103.67	-23.25	3184.00	-44.82	-20.00

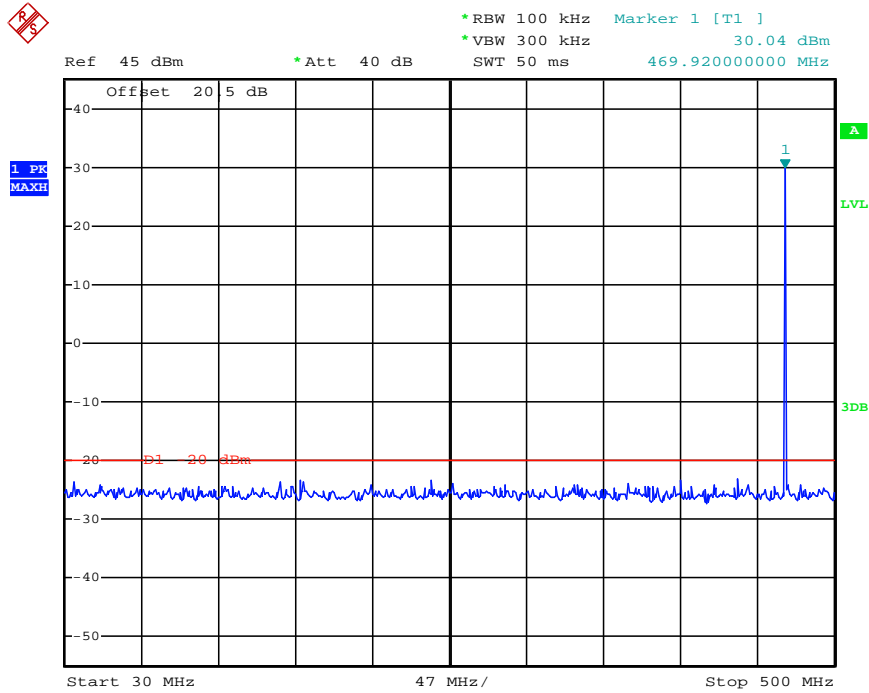

Date: 16.DEC.2013 14:33:41

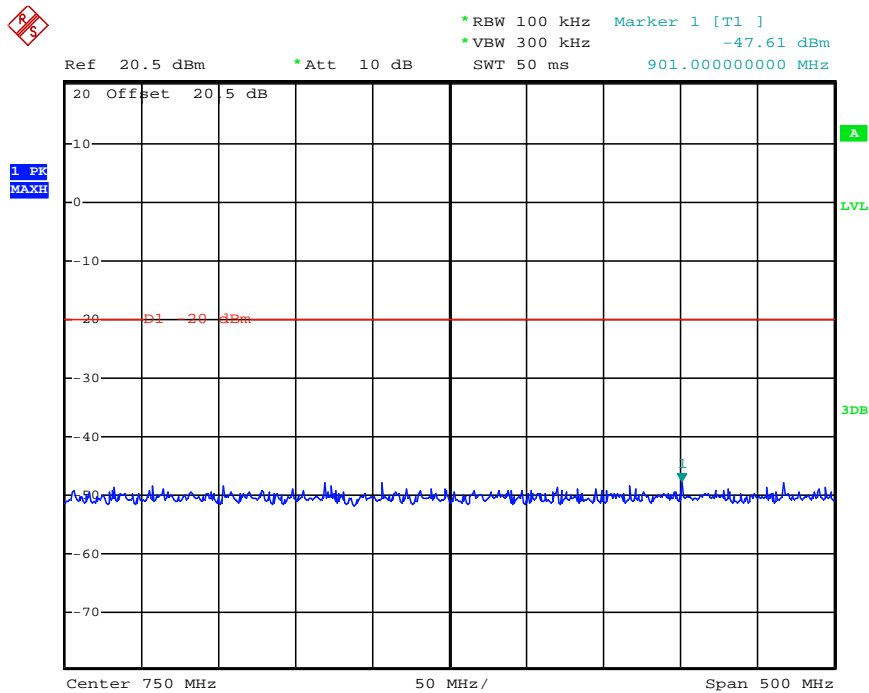

Date: 16.DEC.2013 15:05:12

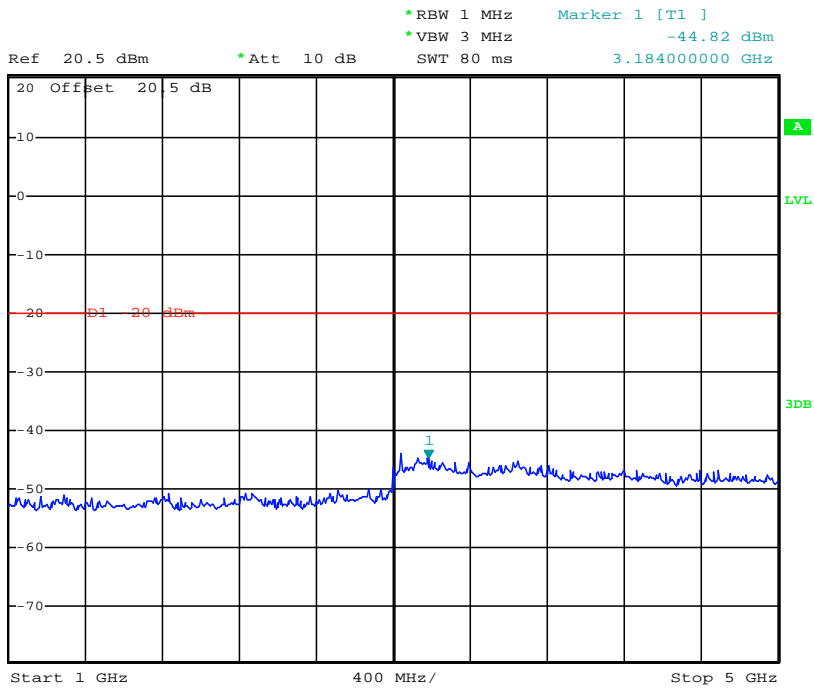

Date: 16.DEC.2013 15:05:41

Operation Mode	Test Channel	Test Frequency (MHz)	Maximum Conducted Spurious Emissions Below 1GHz		Maximum Conducted Spurious Emissions Above 1GHz		Limit (dBm)
			Frequency (MHz)	Datum (dBm)	Frequency (MHz)	Datum (dBm)	
Op 3	Ch4	406.5	436.38	-24.05	3272.00	-43.53	-20.00

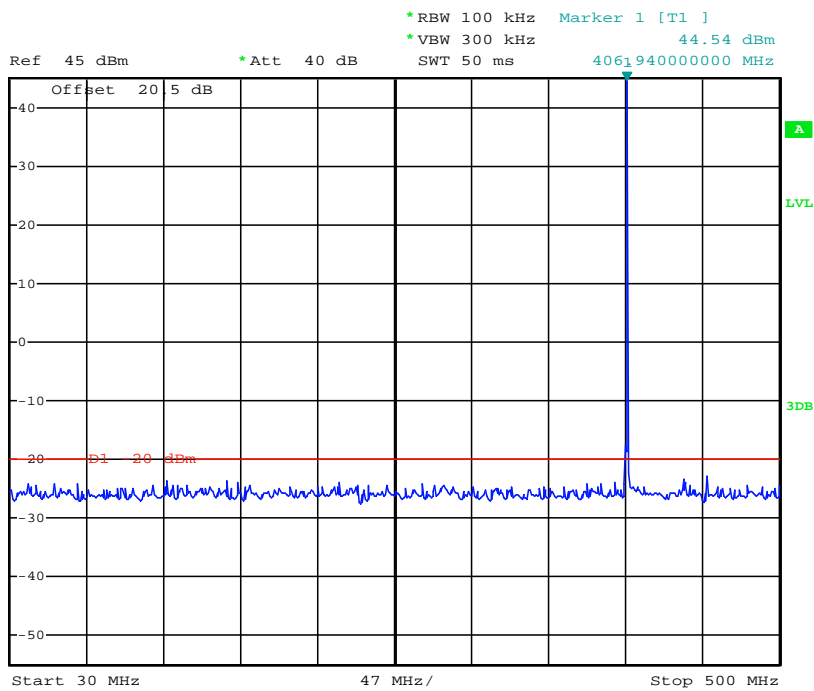

Date: 16.DEC.2013 14:39:28



*RBW 100 kHz Marker 1 [T1]
*VBW 300 kHz -47.87 dBm
SWT 50 ms 813.000000000 MHz

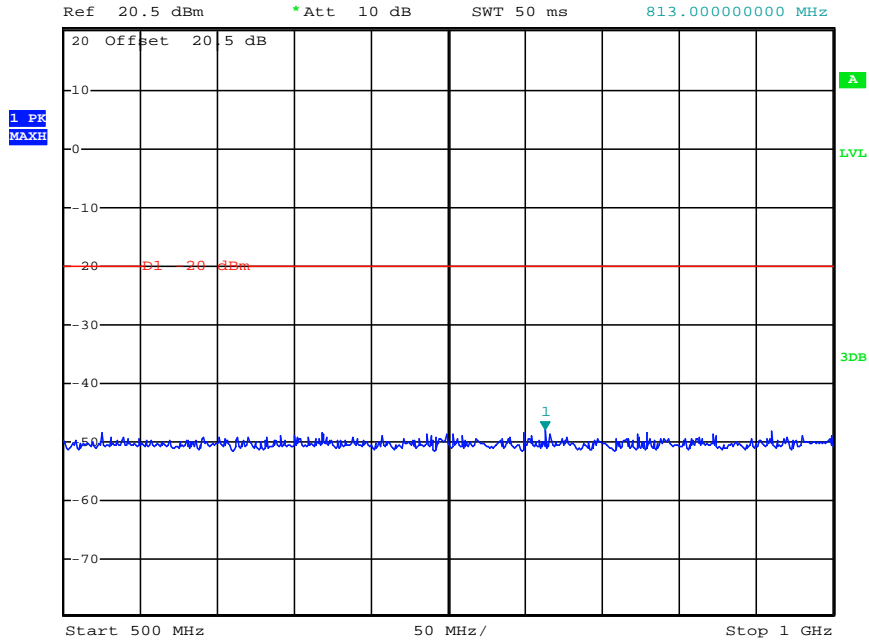

Date: 16.DEC.2013 15:11:04



*RBW 1 MHz Marker 1 [T1]
*VBW 3 MHz -43.53 dBm
SWT 80 ms 3.272000000 GHz

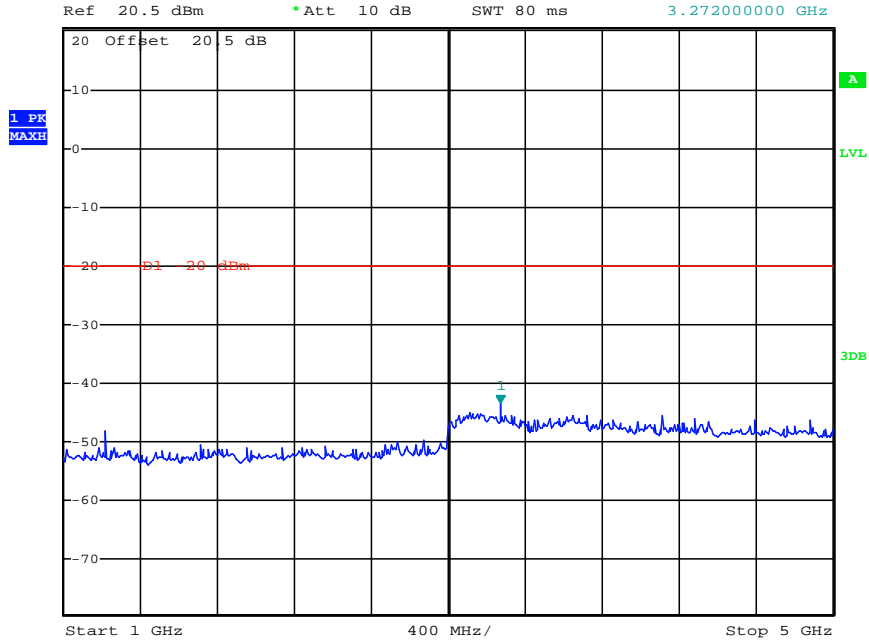

Date: 16.DEC.2013 15:14:50

Operation Mode	Test Channel	Test Frequency (MHz)	Maximum Conducted Spurious Emissions Below 1GHz		Maximum Conducted Spurious Emissions Above 1GHz		Limit (dBm)
			Frequency (MHz)	Datum (dBm)	Frequency (MHz)	Datum (dBm)	
Op 3	Ch5	435.0	268.17	-24.35	3264.00	-44.58	-20.00

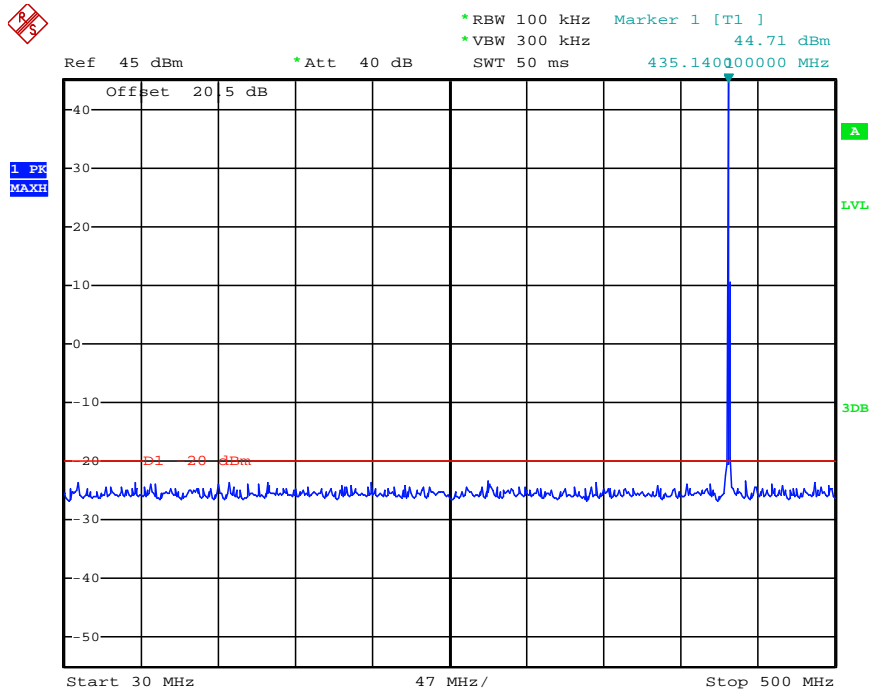

Date: 16.DEC.2013 14:40:33

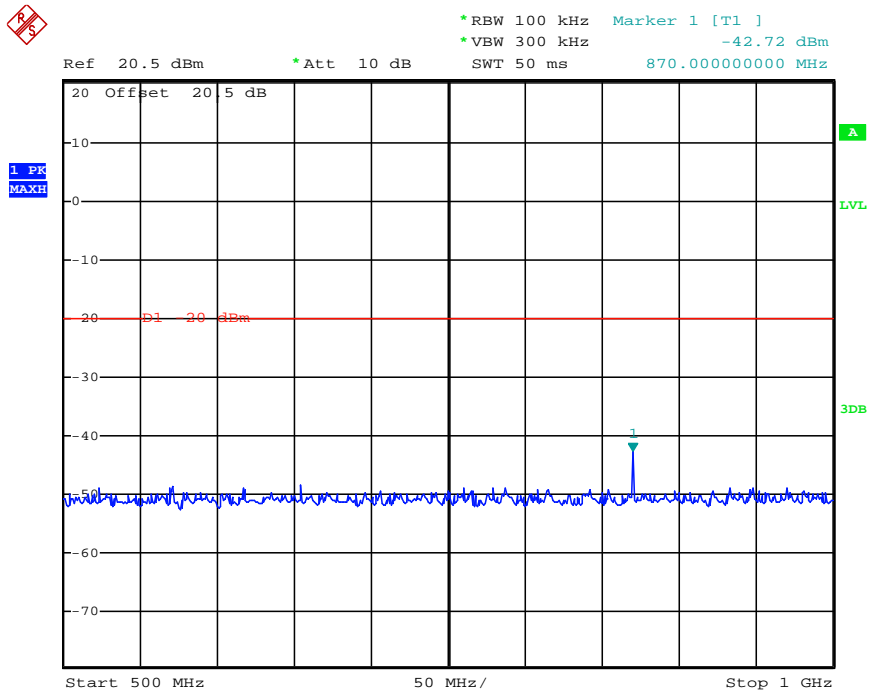

Date: 16.DEC.2013 15:11:52

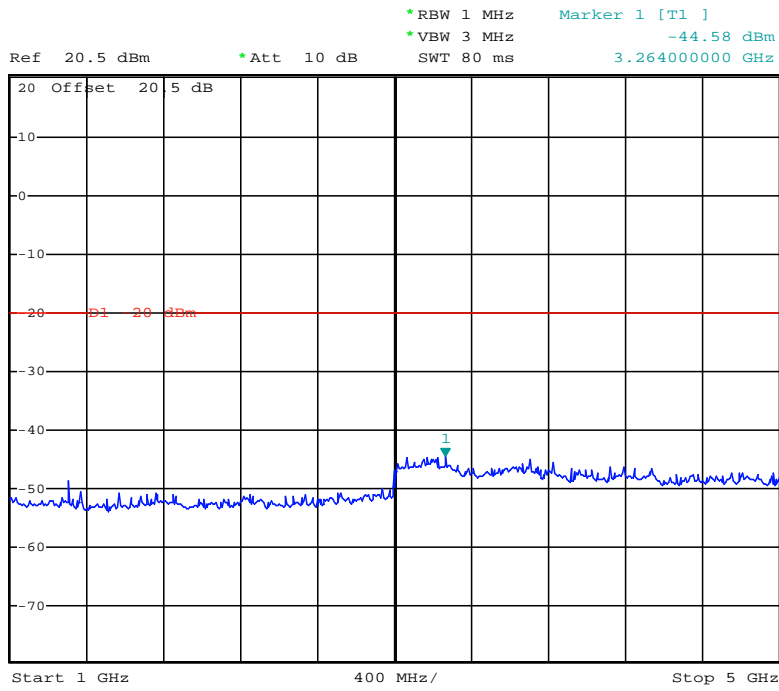

Date: 16.DEC.2013 15:14:01

Operation Mode	Test Channel	Test Frequency (MHz)	Maximum Conducted Spurious Emissions Below 1GHz		Maximum Conducted Spurious Emissions Above 1GHz		Limit (dBm)
			Frequency (MHz)	Datum (dBm)	Frequency (MHz)	Datum (dBm)	
Op 3	Ch6	469.5	138.56	-23.47	3160.00	-44.64	-20.00

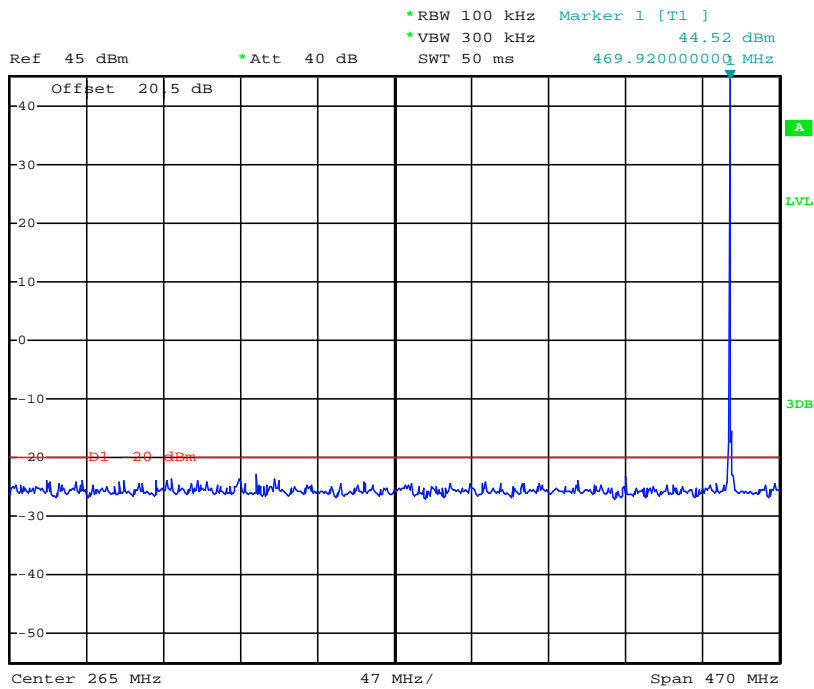

Date: 16.DEC.2013 14:41:20



*RBW 100 kHz Marker 1 [T1]
*VBW 300 kHz -41.97 dBm
SWT 50 ms 939.00000000 MHz

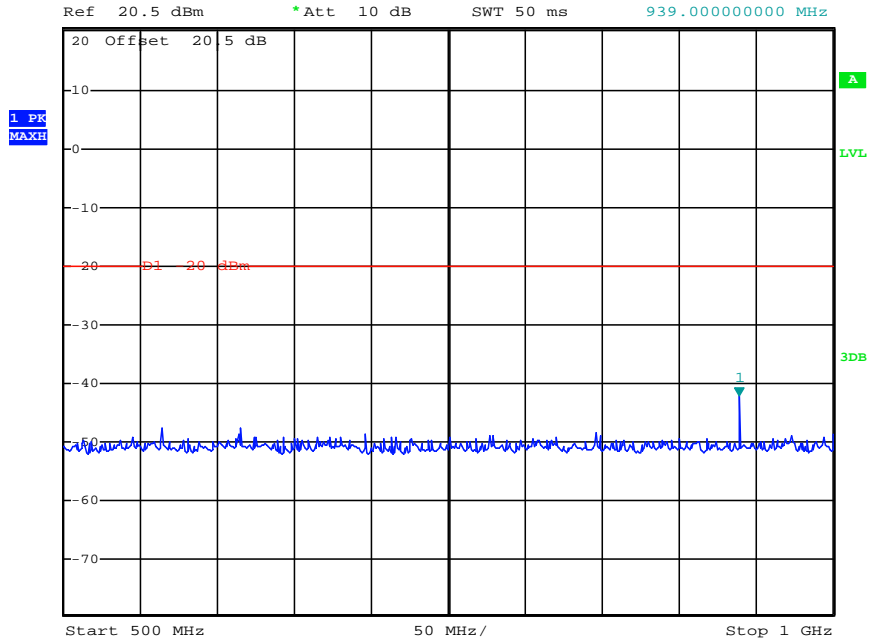

Date: 16.DEC.2013 15:12:37



*RBW 1 MHz Marker 1 [T1]
*VBW 3 MHz -44.64 dBm
SWT 80 ms 3.160000000 GHz

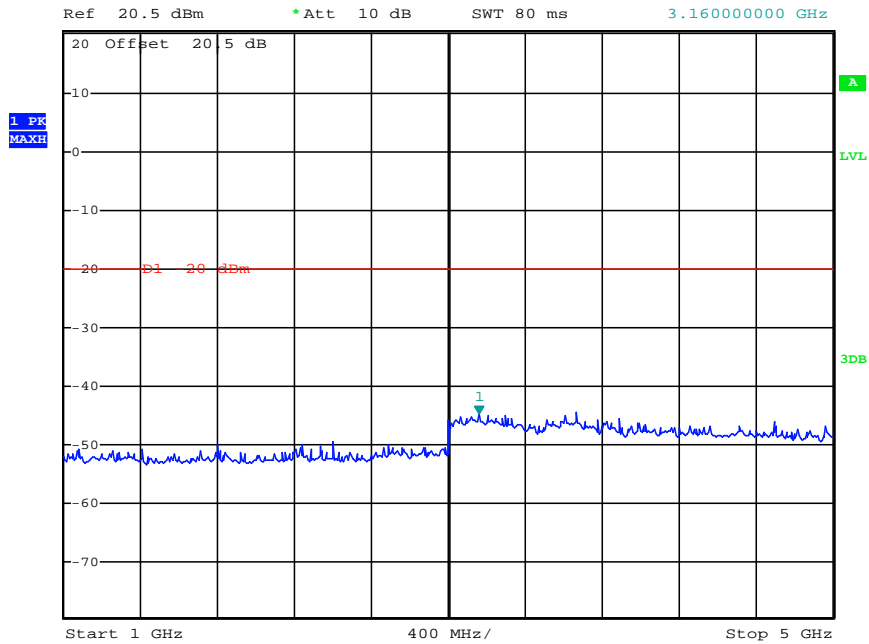

Date: 16.DEC.2013 15:13:07

Operation Mode	Test Channel	Test Frequency (MHz)	Maximum Conducted Spurious Emissions Below 1GHz		Maximum Conducted Spurious Emissions Above 1GHz		Limit (dBm)
			Frequency (MHz)	Datum (dBm)	Frequency (MHz)	Datum (dBm)	
Op 4	Ch4	406.5	273.57	-23.67	3304.00	-44.78	-20.00

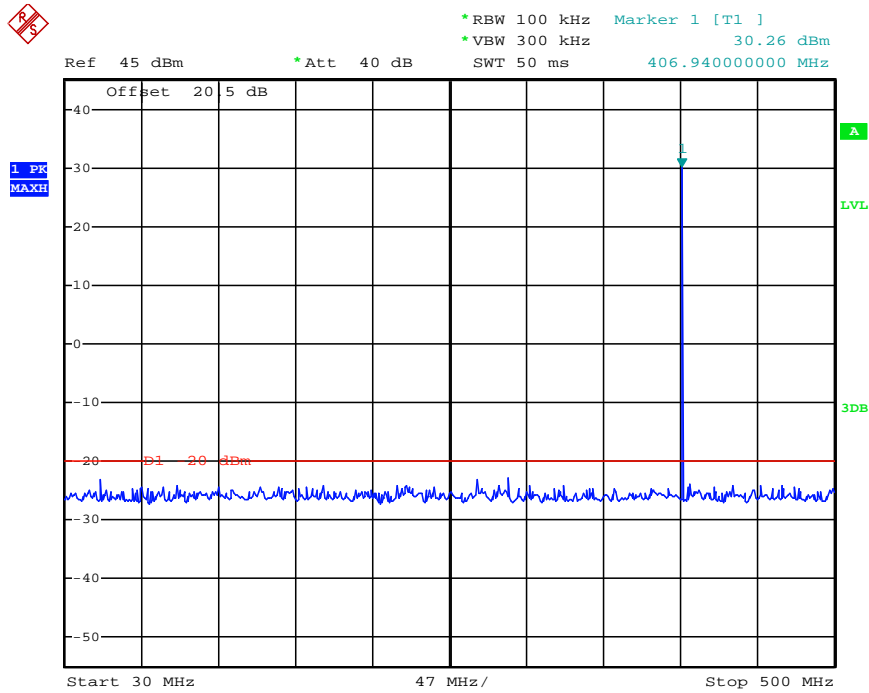

Date: 16.DEC.2013 14:43:15

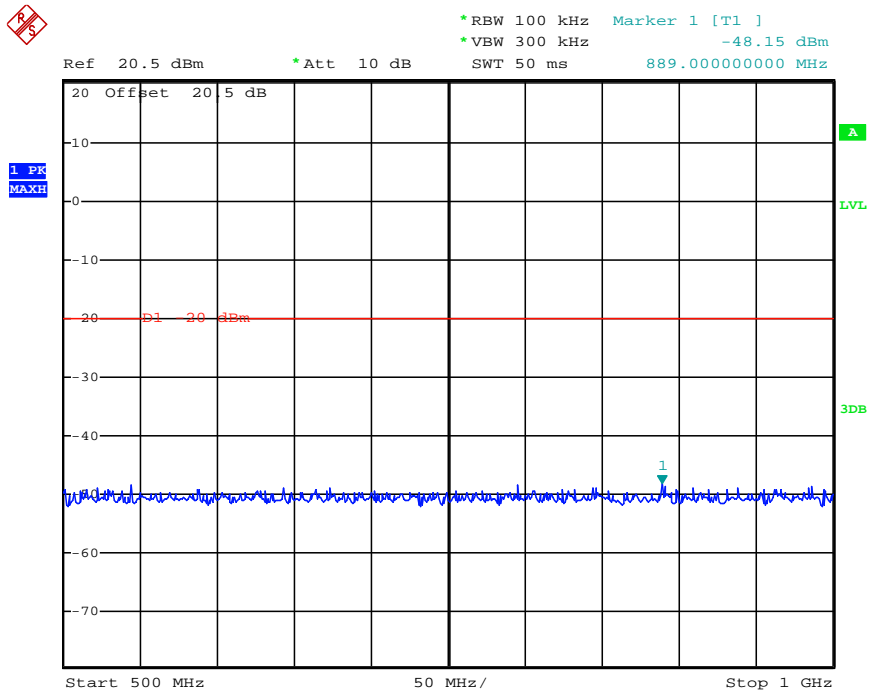

Date: 16.DEC.2013 15:15:53

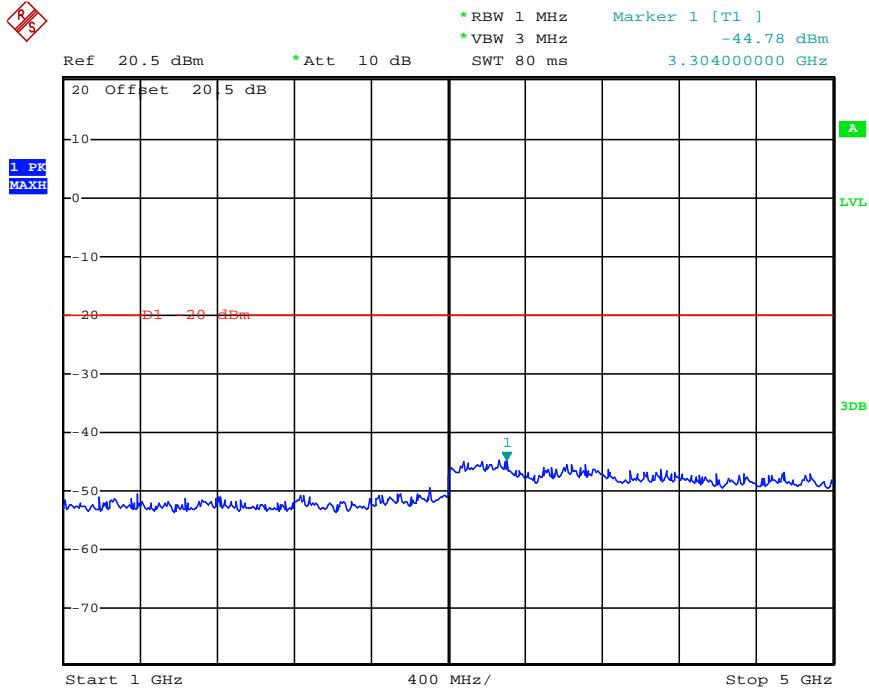

Date: 16.DEC.2013 15:19:17

Operation Mode	Test Channel	Test Frequency (MHz)	Maximum Conducted Spurious Emissions Below 1GHz		Maximum Conducted Spurious Emissions Above 1GHz		Limit (dBm)
			Frequency (MHz)	Datum (dBm)	Frequency (MHz)	Datum (dBm)	
Op 4	Ch5	435.0	235.67	-24.38	3176.00	-44.95	-20.00

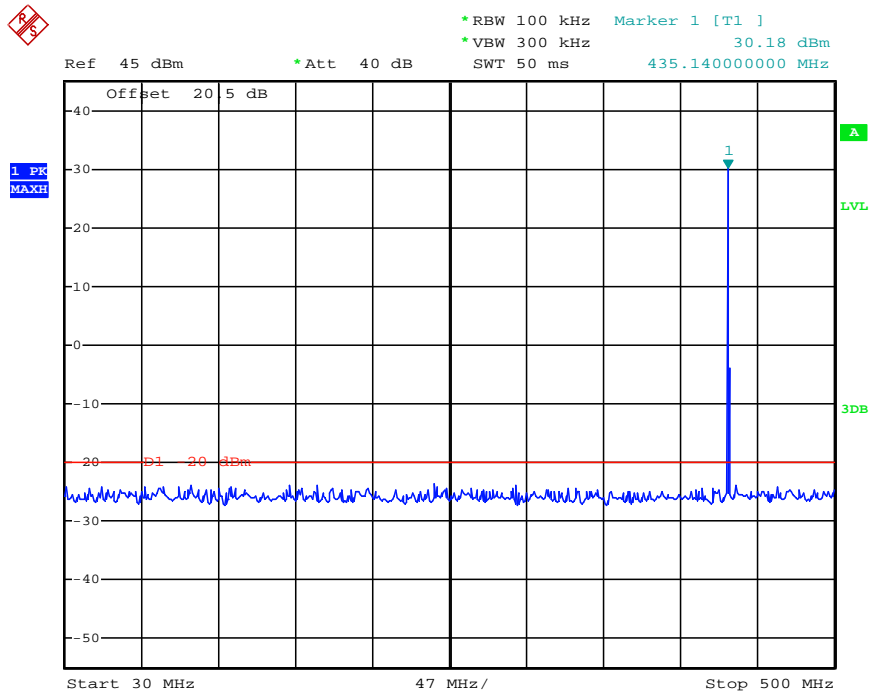

Date: 16.DEC.2013 14:44:16



*RBW 100 kHz Marker 1 [T1]
*VBW 300 kHz -47.74 dBm
SWT 50 ms 574.00000000 MHz

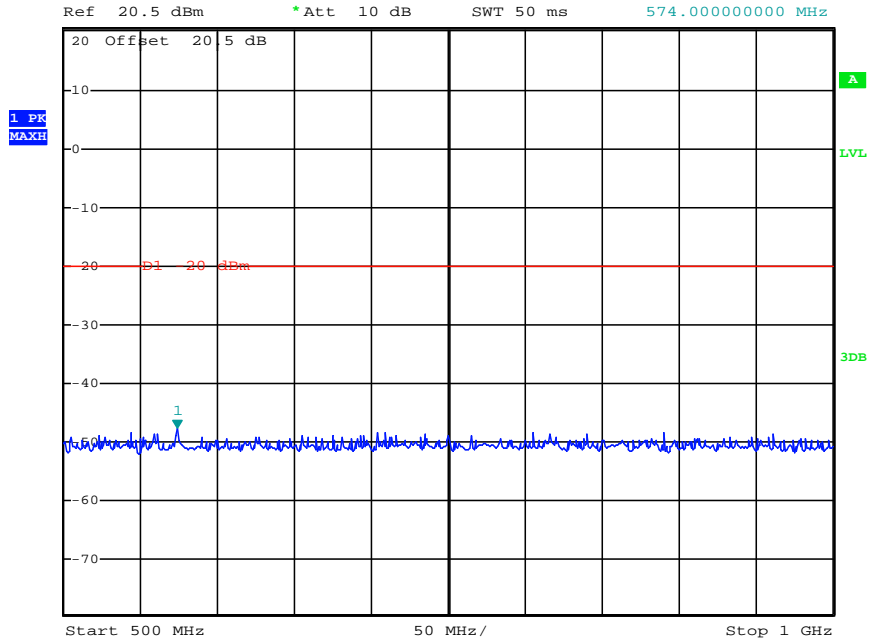

Date: 16.DEC.2013 15:16:35



*RBW 1 MHz Marker 1 [T1]
*VBW 3 MHz -44.95 dBm
SWT 80 ms 3.176000000 GHz

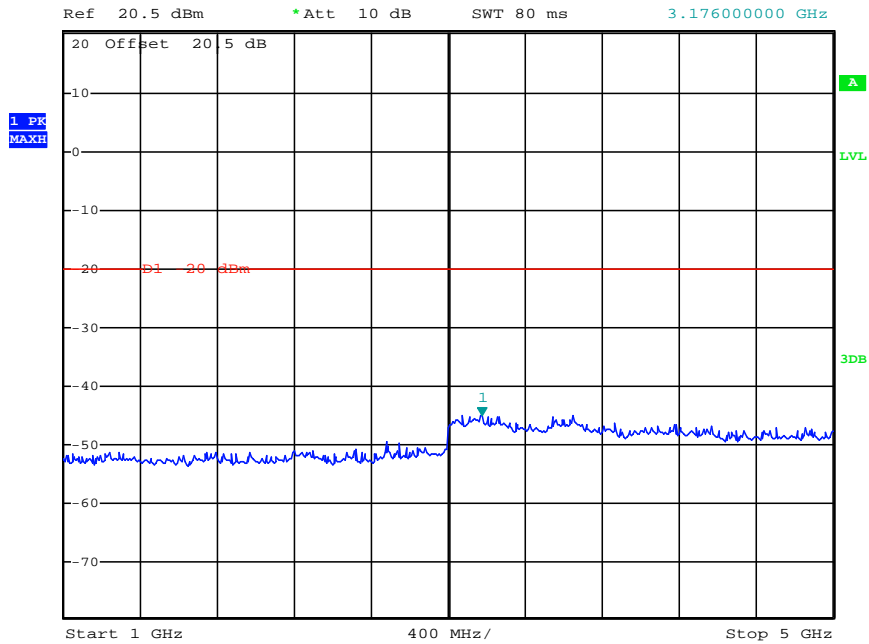

Date: 16.DEC.2013 15:18:31

Operation Mode	Test Channel	Test Frequency (MHz)	Maximum Conducted Spurious Emissions Below 1GHz		Maximum Conducted Spurious Emissions Above 1GHz		Limit (dBm)
			Frequency (MHz)	Datum (dBm)	Frequency (MHz)	Datum (dBm)	
Op 4	Ch6	469.5	378.51	-23.81	3160.00	-44.08	-20.00

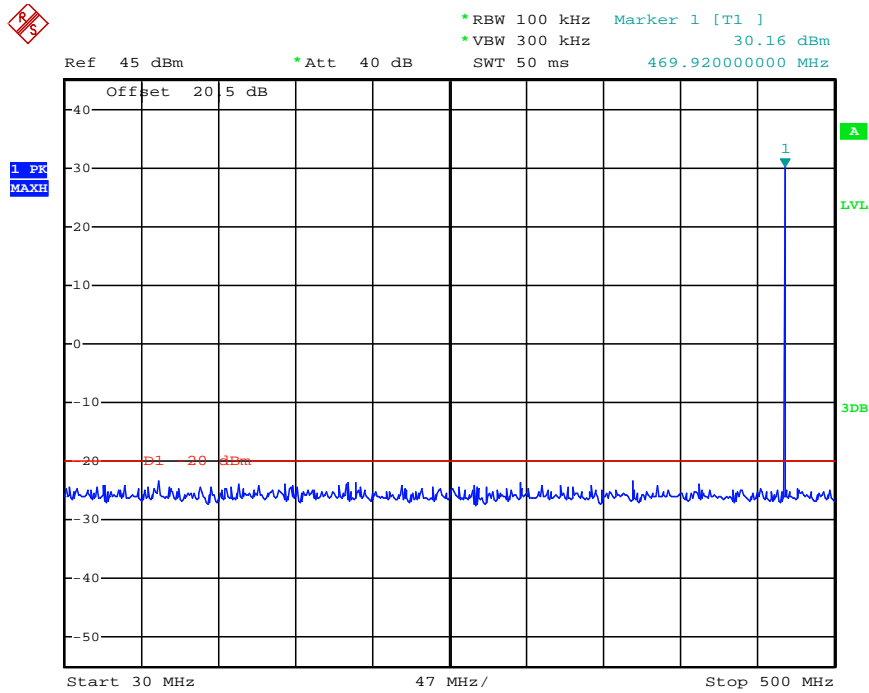

Date: 16.DEC.2013 14:45:09

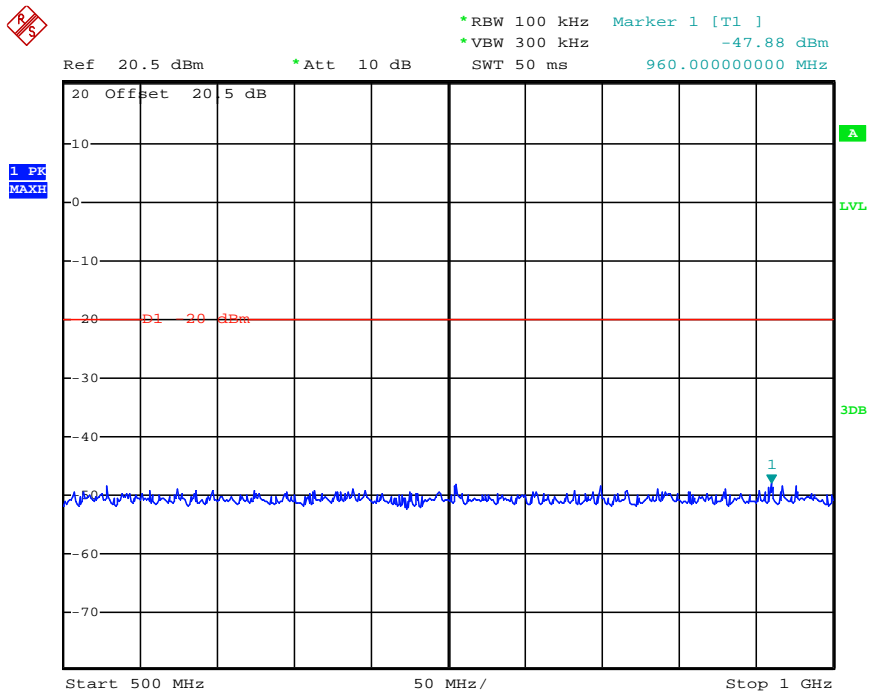

Date: 16.DEC.2013 15:17:25



*RBW 1 MHz Marker 1 [T1]
*VBW 3 MHz -44.08 dBm
SWT 80 ms 3.16000000 GHz

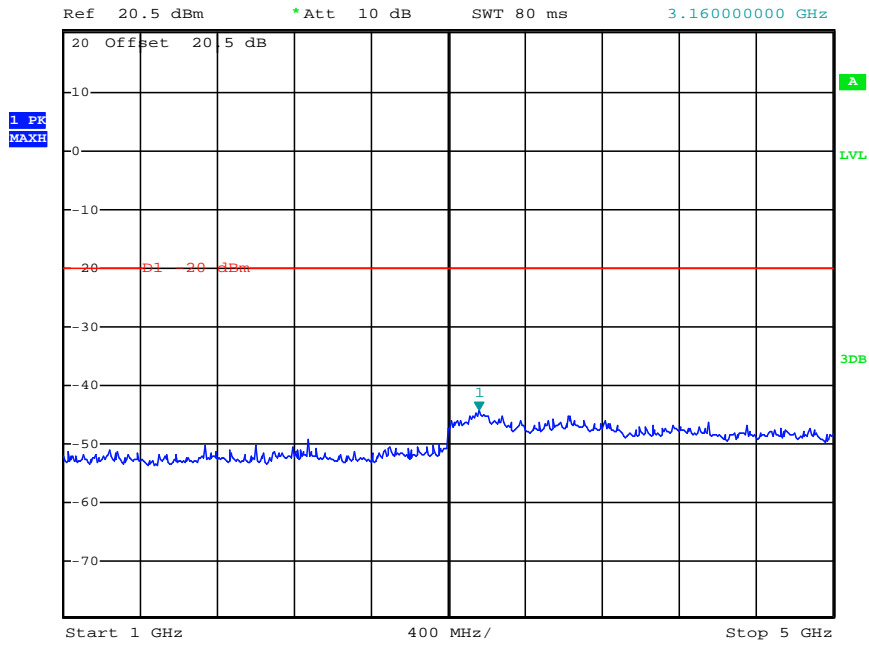

Date: 16.DEC.2013 15:17:46

4.5. Modulation Characteristics

TEST APPLICABLE

According to CFR47 section 2.1047(a), for Voice Modulation Communication Equipment, the frequency response of the audio modulation circuit over a range of 100 to 5000Hz shall be measured.

TEST PROCEDURE

Modulation Limit

- 1 Configure the EUT as shown in figure 1, adjust the audio input for 60% of rated system deviation at 1 KHz using this level as a reference (0dB) and vary the input level from -20 to +20dB. Record the frequency deviation obtained as a function of the input level.
- 2 Repeat step 1 with input frequency changing to 300, 1004, 1500 and 2500Hz in sequence.

Audio Frequency Response

- 1 Configure the EUT as shown in figure 1.
- 2 Adjust the audio input for 20% of rated system deviation at 1 KHz using this level as a reference (0dB).
- 3 Vary the Audio frequency from 100 Hz to 3 KHz and record the frequency deviation.
- 4 Audio Frequency Response = $20\log_{10}$ (Deviation of test frequency/Deviation of 1 KHz reference).

TEST CONFIGURATION

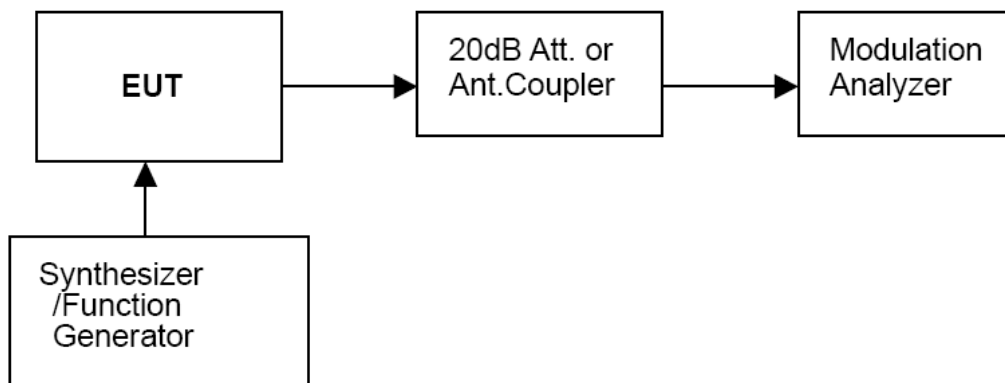

TEST RESULTS

Remark: We tested Op 1 to Op 2. recorded worst case at Op 1.

Modulation Type: FM

12.5 KHz Channel Separation

Modulation Level (dB)	Peak Freq. Deviation At 300 Hz (KHz)	Peak Freq. Deviation At 1004 Hz (KHz)	Peak Freq. Deviation At 1500 Hz (KHz)	Peak Freq. Deviation At 2500 Hz (KHz)
-20	0.15	0.24	0.35	0.48
-15	0.27	0.38	0.48	0.65
-10	0.35	0.69	0.86	1.34
-5	0.55	1.01	1.37	2.10
0	0.56	1.65	2.25	2.30
+5	0.79	2.46	2.27	2.35
+10	1.15	2.40	2.26	2.37
+15	2.35	2.41	2.27	2.36
+20	2.38	2.41	2.28	2.35

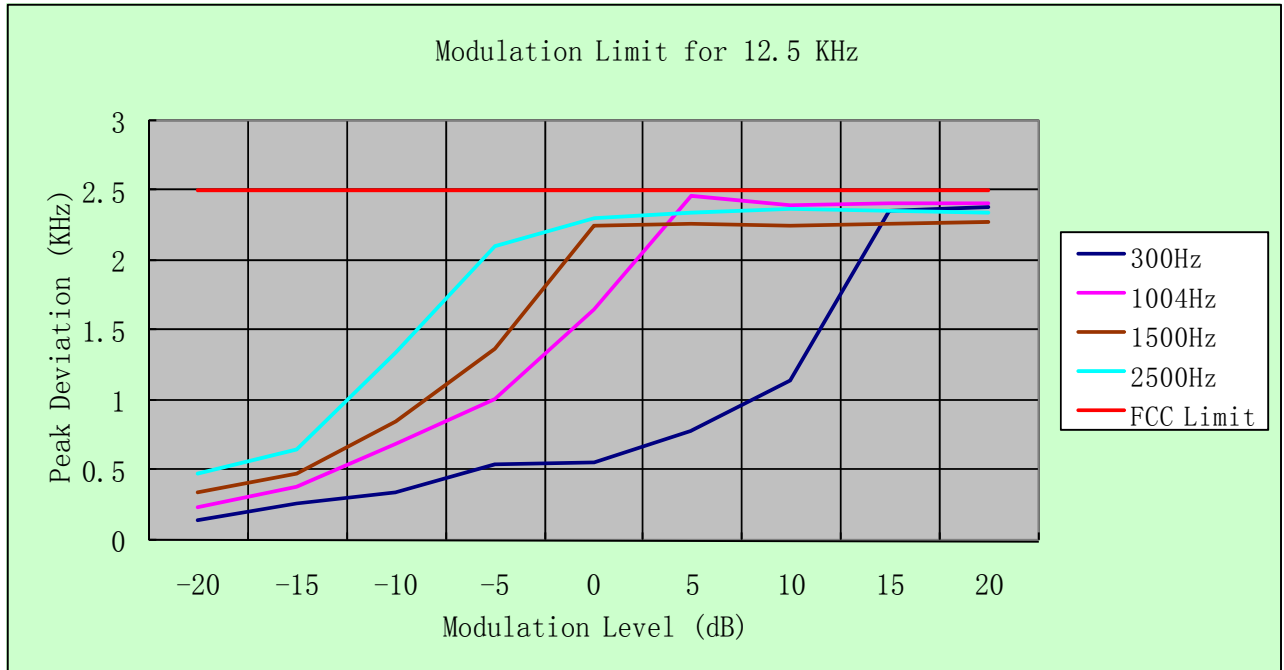

Modulation type: 4FSK

Channel bandwidth: 12.5 kHz

It is not applicable for devices which operate with the digitized voice/data modulation type.

b). Audio Frequency Response:

Rule Part No.: Part 2.1407(a) (b)

Method of Measurement:

The audio frequency response was measured in accordance with TIA/EIA Specification 603 with no exception. A curve or equivalent data showing the frequency response of the audio modulating circuit over a range of 300-3000Hz shall be submitted and Audio Post Limiter Low Pass Filter Response from 3.0 KHz to 50KHz. However, the audio frequency response should test from 100Hz to 5.0 KHz according to FCC Part 90.

Modulation Type: FM

The audio frequency response curve is show below.and

Test Audio Level (1 KHz and 20% maximum deviation) for 12.5 KHz channel separation is 2.80mv.

Note:

1. Not applicable to new standard. However, tests are conducted under FCC's recommendation.
2. The Audio Frequency Response is identical for 12.5 KHz channel separation

12.5 KHz Channel Separation

Frequency (KHz)	Frequency Deviation (KHz)	1KHz Referece Deviation (KHz)	Audio Frequency Response (dB)
0.1	0.06	0.52	-18.76
0.2	0.06	0.52	-18.76
0.3	0.14	0.52	-11.11
0.4	0.14	0.52	-11.21
0.5	0.15	0.52	-10.80
0.6	0.28	0.52	-5.36
0.7	0.28	0.52	-5.39
0.8	0.32	0.52	-4.22
0.9	0.41	0.52	-2.06
1.0	0.52	0.52	0.00
1.2	0.55	0.52	0.49

1.4	0.60	0.52	1.24
1.6	0.62	0.52	1.53
1.8	0.79	0.52	3.58
2.0	0.84	0.52	4.18
2.2	1.01	0.52	5.77
2.4	1.07	0.52	6.27
2.6	1.17	0.52	7.04
2.7	1.22	0.52	7.41
2.8	1.22	0.52	7.42
3.0	1.24	0.52	7.58
3.5	1.24	0.52	7.55
4.0	0.06	0.52	-18.76
4.5	0.06	0.52	-18.76
5.0	0.06	0.52	-18.76

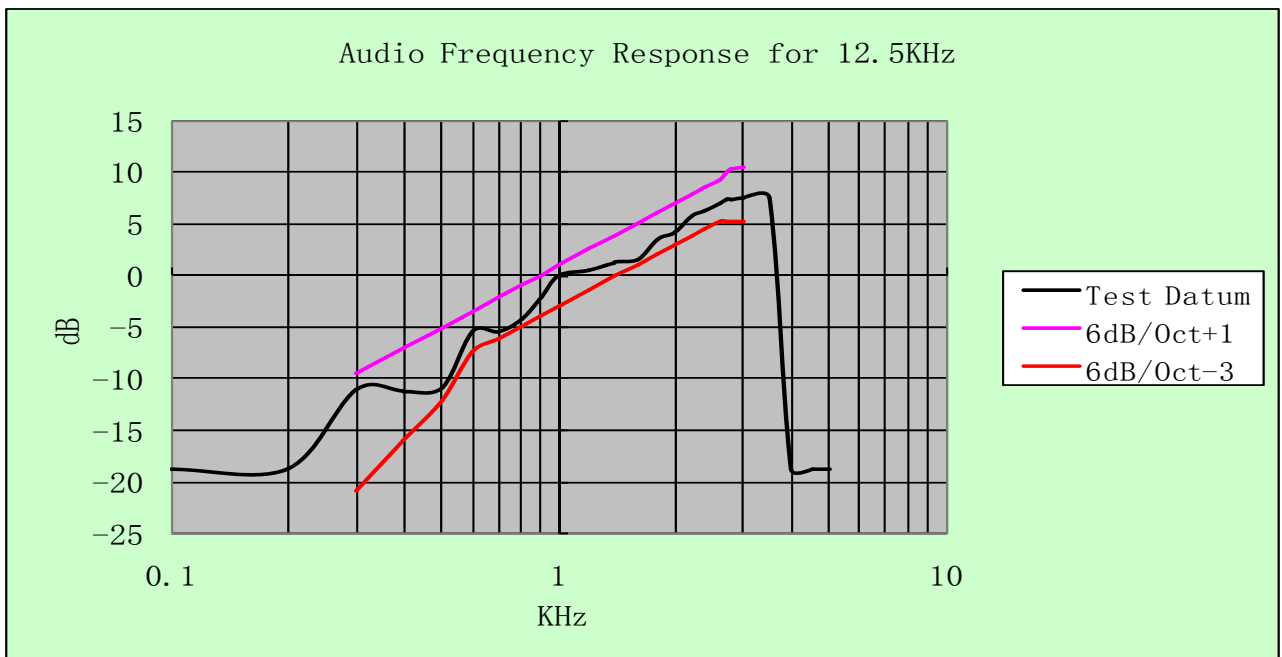

Modulation type: 4FSK

Channel bandwidth: 12.5 kHz

It is not applicable for devices which operate with the digitized voice/data modulation type.

4.6. Frequency Stability Test

TEST APPLICABLE

- 1 According to FCC Part 2 Section 2.1055 (a)(1), the frequency stability shall be measured with variation of ambient temperature from -30°C to +60°C centigrade.
- 2 According to FCC Part 2 Section 2.1055 (d) (2), for battery powered equipment, the frequency stability shall be measured with reducing primary supply voltage to the battery operating end point, which is specified by the manufacture.
- 3 Vary primary supply voltage from 85 to 115 percent of the nominal value.
- 4 According to §90.213, the frequency stability limit is 2.5 ppm for 12.5KHz channel separation

TEST PROCEDURE

The EUT was set in the climate chamber and connected to an external DC power supply. The RF output was directly connected to Spectrum Analyzer ESI 26. The coupling loss of the additional cables was recorded and taken in account for all the measurements. After temperature stabilization (approx. 20 min for each stage), the frequency for the lower, the middle and the highest frequency range was recorded. For Frequency stability Vs. Voltage the EUT was connected to a DC power supply and the voltage was adjusted in the required ranges. The result was recorded.

TEST CONFIGURATION

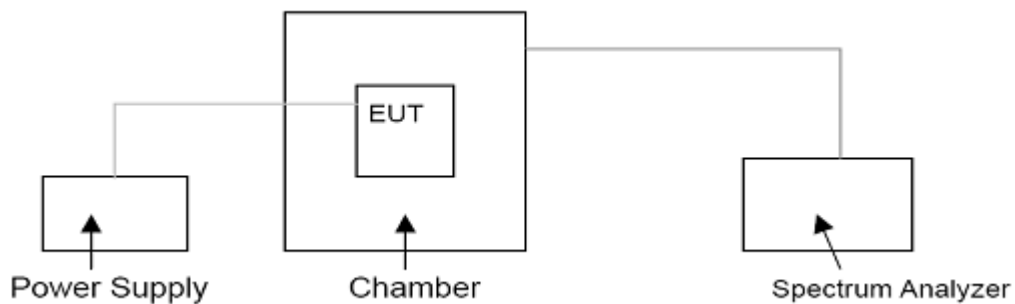

TEST LIMITS

According to 90.213, Transmitters used must have minimum frequency stability as specified in the following table.

Frequency Range (MHz)	Channel Bandwidth (KHz)	Frequency Tolerance (ppm)		
		Fixed and Base Stations	Mobile Stations	
			> 2 W	≤ 2 W
150-174 MHz	6.25	1.0	2.0	2.0
	12.5	2.5	5.0	5.0
	25	5.0	5.0	50.0*
421-512 MHz	6.25	0.5	1.0	1.0
	12.5	1.5	2.5	2.5
	25	2.5	5.0	5.0

- Stations operating in the 154.45 to 154.49 MHz or the 173.2 to 173.4 MHz bands must have a frequency stability of 5 ppm.
- Paging transmitters operating on paging-only frequencies must operate with frequency stability of 5 ppm in the 150-174 MHz band and 2.5 ppm in the 421-512 MHz band.

TEST RESULTS

Remark: We tested Op 1 to Op 4, recorded worst case at Op 1, Op 3

Operation Mode	Channel Separation	Test conditions		Frequency error (ppm)		
		Voltage(V)	Temp(°C)	406.5	435	469.5
Op 1	12.5KHz	13.6	-30	1.00	1.01	0.99
			-20	0.82	0.83	0.81
			-10	0.78	0.77	0.79
			0	0.75	0.76	0.75
			10	0.79	0.78	0.78
			20	0.55	0.56	0.55
			30	0.86	0.84	0.85
			40	0.92	0.91	0.93
			50	1.01	1.02	1.00
		11.56 (85% Rated)	20	0.88	0.95	0.93
		15.64(115% Rated)	20	0.79	0.75	0.78
Limit			2.5 ppm			
Test Results			PASS			

Operation Mode	Channel Separation	Test conditions		Frequency error (ppm)		
		Voltage(V)	Temp(°C)	406.5	435	469.5
Op3	12.5KHz	13.6	-30	1.01	1.03	1.01
			-20	0.84	0.82	0.83
			-10	0.79	0.78	0.77
			0	0.76	0.75	0.75
			10	0.80	0.79	0.79
			20	0.54	0.55	0.53
			30	0.87	0.83	0.82
			40	0.91	0.90	0.90
			50	1.00	1.01	1.01
		11.56 (85% Rated)	20	0.94	0.94	0.94
		15.64(115% Rated)	20	0.79	0.78	0.78
Limit			2.5 ppm			
Test Results			PASS			

4.7. Maximum Transmitter Power

TEST APPLICABLE

Per FCC Part 2.1046 and Part 90.205: Maximum ERP is dependent upon the station's antenna HAAT and required service area.

Per RSS-119 Section 5.4 and 5.4.1: The output power shall be within ± 1.0 dB of the manufacturer's rated power. Typical transmitter output powers are 110 watts for base and/or fixed stations (paging transmitters excepted), and 30 watts for mobile stations. Higher powers may be certified, but it should be noted that mobile stations are normally only licensed up to 30 watts. See the SRSP relevant to the operating frequency for equipment power limits.

TEST PROCEDURE

Measurements shall be made to establish the radio frequency power delivered by the transmitter the standard output termination. The power output shall be monitored and recorded and no adjustment shall be made to the transmitter after the test has begun, except as noted below:

If the power output is adjustable, measurements shall be made for the highest and lowest power levels.

The EUT connect to the Receiver through 20 dB attenuator.

Measurement with Spectrum Analyzer FSP40 conducted, external power supply with 13.60 V stabilized supply voltage.

TEST CONFIGURATION

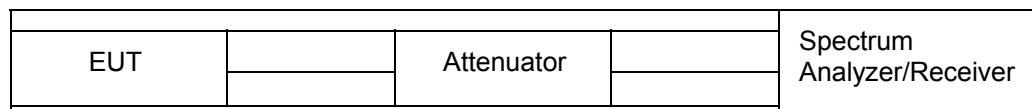

The EUT was directly connected to a RF Communication Test set by a 20 dB attenuator

TEST RESULTS

Modulation Type	Channel SpARATION	Operation Mode	Test Channel	Test Frequency (MHz)	Test Results (dBm)
Analog/FM	12.5KHz	Op 1	Ch1	406.5	44.59
			Ch2	435.0	44.70
			Ch3	469.5	44.58
		Op 2	Ch1	406.5	30.24
			Ch2	435.0	30.02
			Ch3	469.5	30.29
Digital	12.5KHz	Op 3	Ch4	406.5	44.74
			Ch5	435.0	44.69
			Ch6	469.5	44.74
		Op 4	Ch4	406.5	30.50
			Ch5	435.0	30.26
			Ch6	469.5	30.38
Limit	The limit is dependent upon the station's antenna HAAT and required service area.				
Test Results		PASS			

Plots of Transmitter Power Measurement

Modulation Type	Channel Separation	Operation Mode	Test Channel	Test Frequency (MHz)	Rated Power (Watt)	Measurement (dBm)	Limit	Results
FM	12.5KHz	Op 1	Ch1	406.5	25	44.59	Varies	PASS

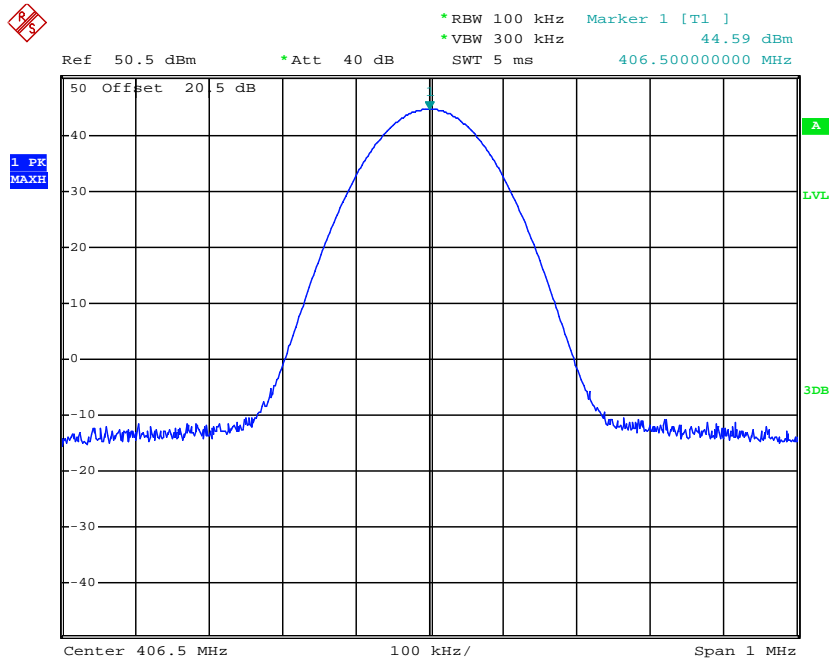

Date: 12.DEC.2013 14:51:32

Modulation Type	Channel Separation	Operation Mode	Test Channel	Test Frequency (MHz)	Rated Power (Watt)	Measurement (dBm)	Limit	Results
FM	12.5KHz	Op 1	Ch2	435.0	25	44.70	Varies	PASS

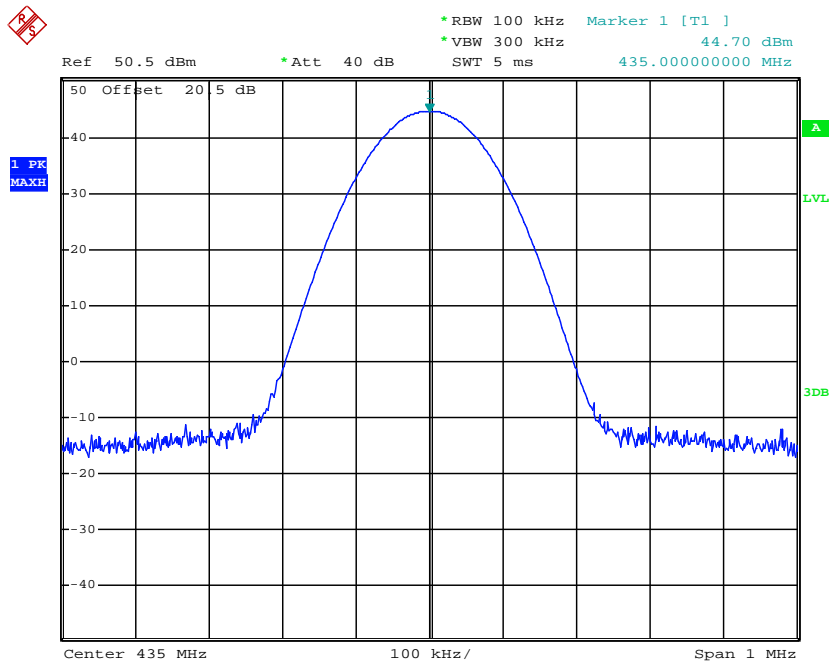

Date: 12.DEC.2013 14:54:49

Modulation Type	Channel Separation	Operation Mode	Test Channel	Test Frequency (MHz)	Rated Power (Watt)	Measurement (dBm)	Limit	Results
FM	12.5KHz	Op 1	Ch3	469.5	25	44.58	Varies	PASS

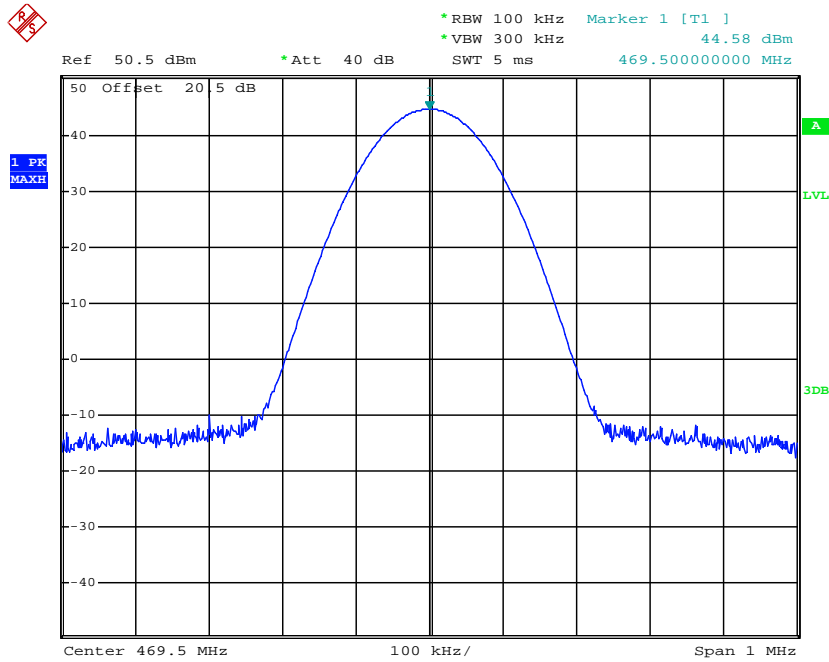

Date: 12.DEC.2013 15:03:39

Modulation Type	Channel Separation	Operation Mode	Test Channel	Test Frequency (MHz)	Rated Power (Watt)	Measurement (dBm)	Limit	Results
FM	12.5KHz	Op 2	Ch1	406.5	1	30.24	Varies	PASS

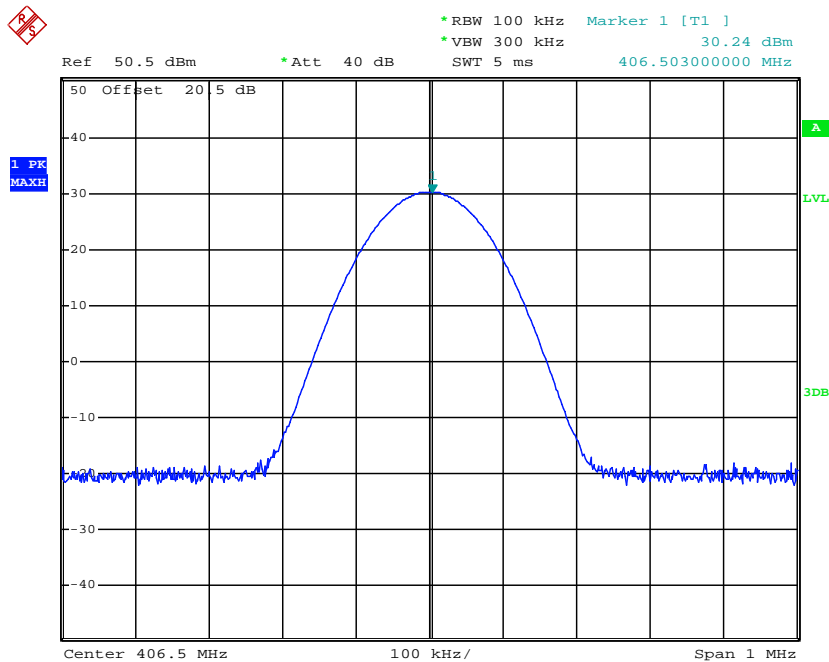

Date: 12.DEC.2013 14:52:04

Modulation Type	Channel Separation	Operation Mode	Test Channel	Test Frequency (MHz)	Rated Power (Watt)	Measurement (dBm)	Limit	Results
FM	12.5KHz	Op 2	Ch2	435.0	1	30.02	Varies	PASS

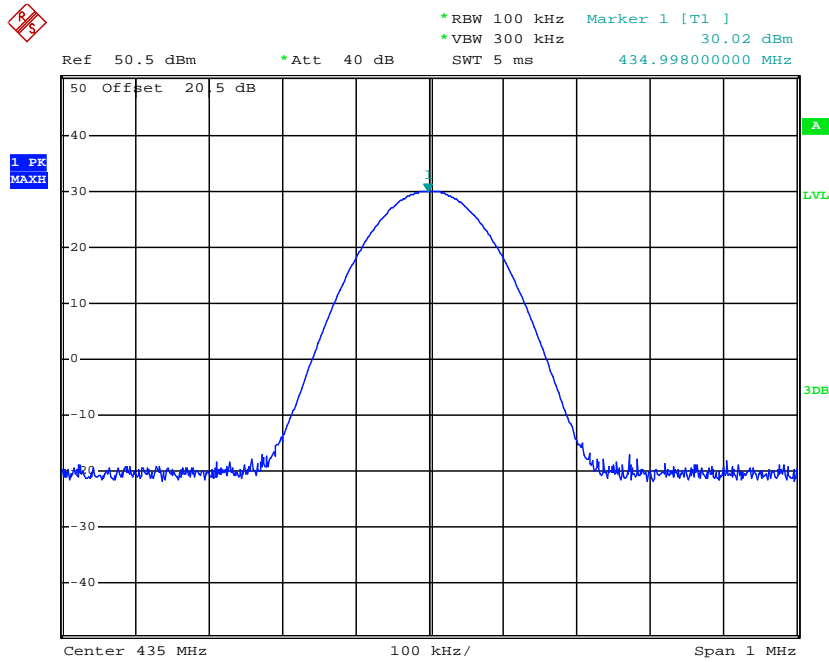

Date: 12.DEC.2013 14:55:14

Modulation Type	Channel Separation	Operation Mode	Test Channel	Test Frequency (MHz)	Rated Power (Watt)	Measurement (dBm)	Limit	Results
FM	12.5KHz	Op 2	Ch3	469.5	1	30.29	Varies	PASS

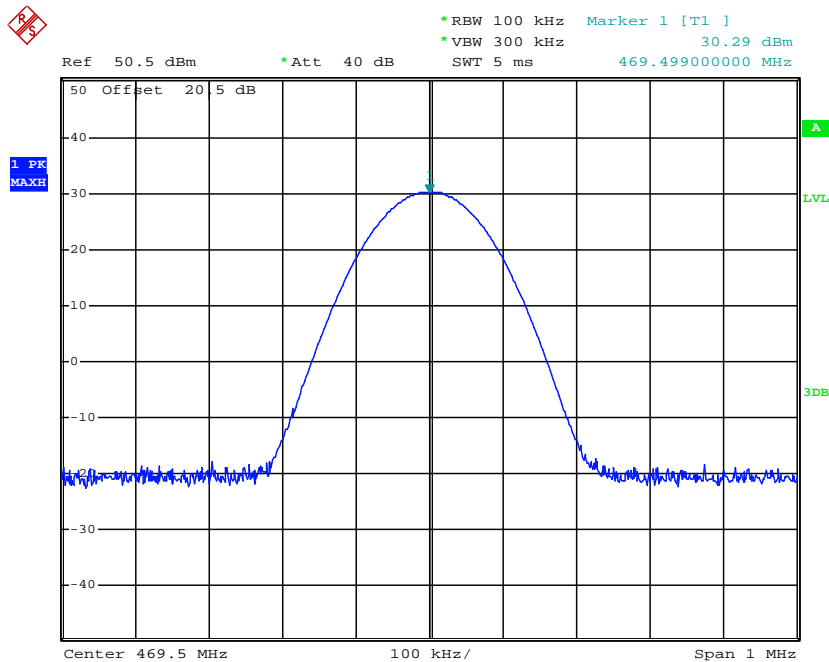

Date: 12.DEC.2013 15:03:55

Modulation Type	Channel Separation	Operation Mode	Test Channel	Test Frequency (MHz)	Rated Power (Watt)	Measurement (dBm)	Limit	Results
4FSK	12.5KHz	Op 3	Ch4	406.5	25	44.74	Varies	PASS

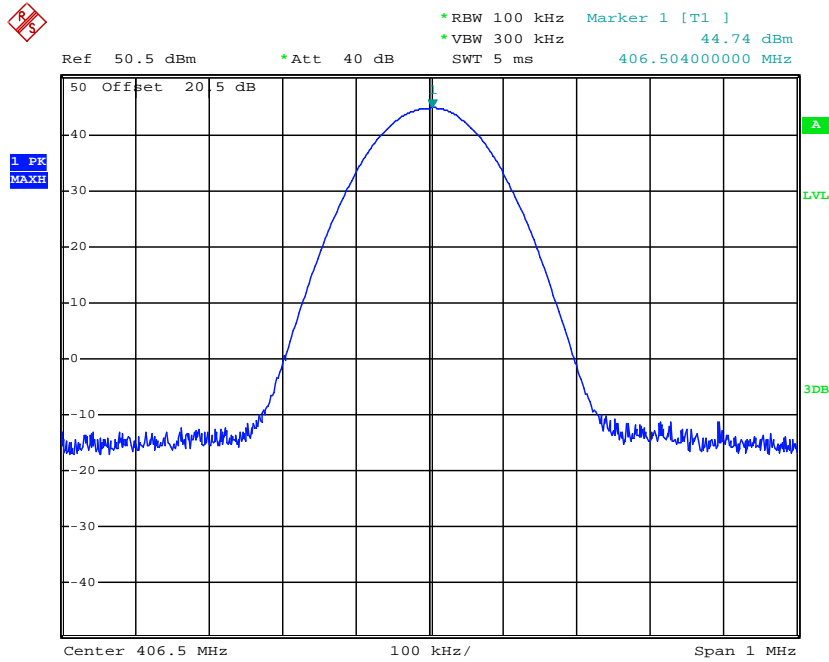

Date: 12.DEC.2013 15:06:32

Modulation Type	Channel Separation	Operation Mode	Test Channel	Test Frequency (MHz)	Rated Power (Watt)	Measurement (dBm)	Limit	Results
4FSK	12.5KHz	Op 3	Ch5	435.0	25	44.69	Varies	PASS

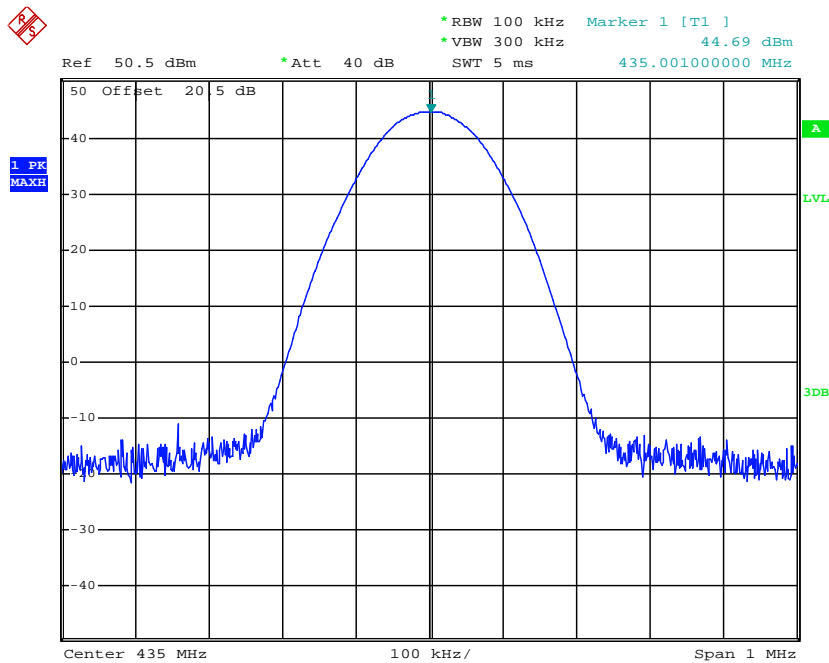

Date: 12.DEC.2013 15:11:35

Modulation Type	Channel Separation	Operation Mode	Test Channel	Test Frequency (MHz)	Rated Power (Watt)	Measurement (dBm)	Limit	Results
4FSK	12.5KHz	Op 3	Ch6	469.5	25	44.74	Varies	PASS

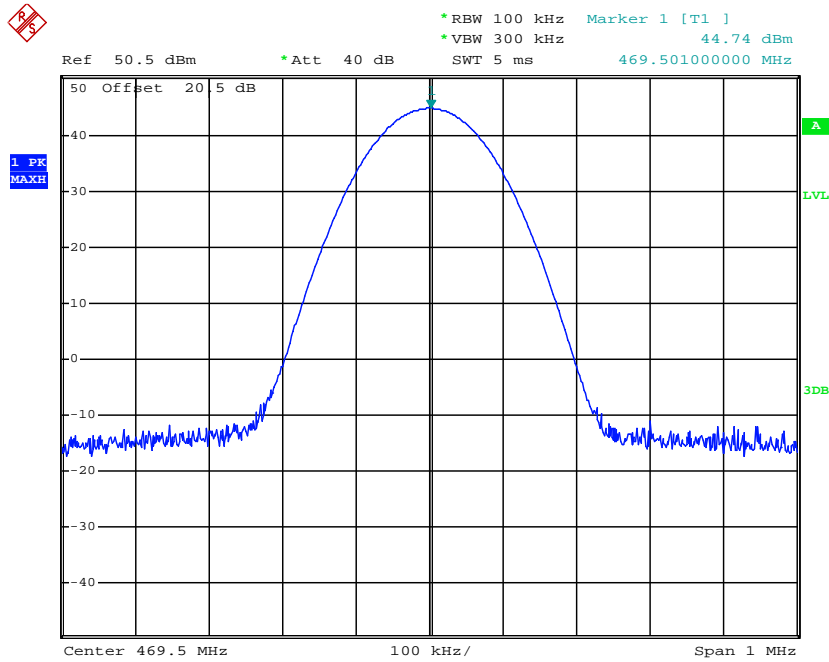

Date: 12.DEC.2013 15:15:06

Modulation Type	Channel Separation	Operation Mode	Test Channel	Test Frequency (MHz)	Rated Power (Watt)	Measurement (dBm)	Limit	Results
4FSK	12.5KHz	Op 4	Ch4	406.5	1	30.50	Varies	PASS

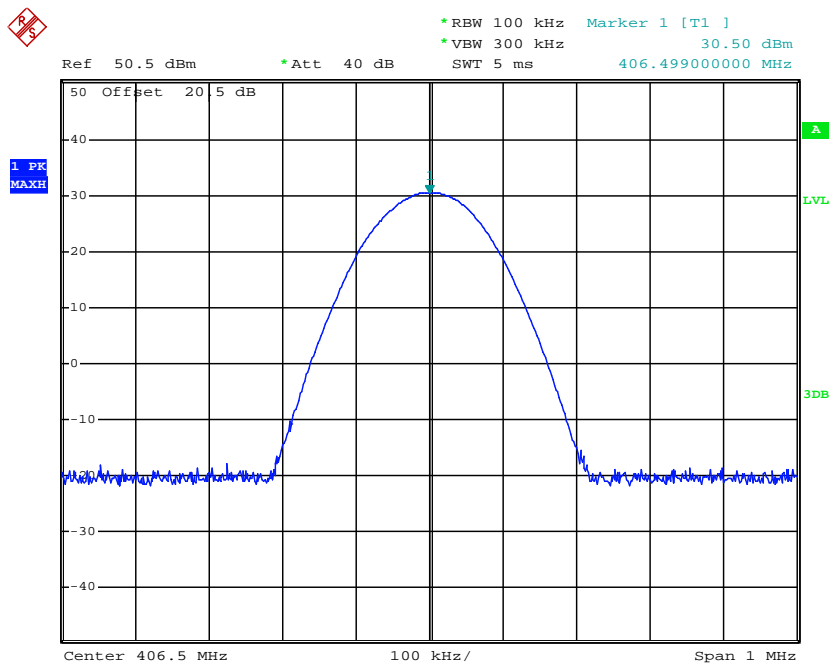

Date: 12.DEC.2013 15:08:25

Modulation Type	Channel Separation	Operation Mode	Test Channel	Test Frequency (MHz)	Rated Power (Watt)	Measurement (dBm)	Limit	Results
4FSK	12.5KHz	Op 4	Ch5	435.0	1	30.26	Varies	PASS

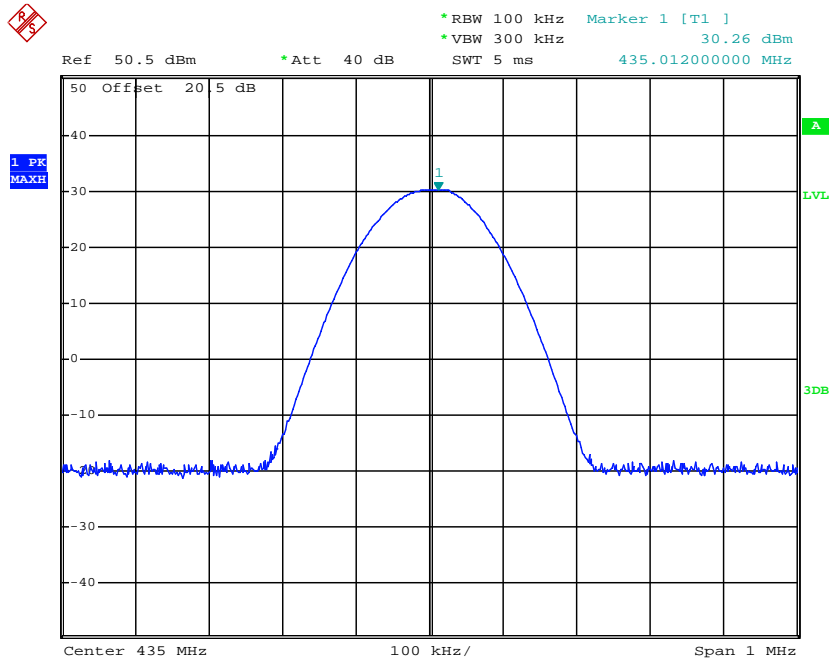

Date: 12.DEC.2013 15:12:46

Modulation Type	Channel Separation	Operation Mode	Test Channel	Test Frequency (MHz)	Rated Power (Watt)	Measurement (dBm)	Limit	Results
4FSK	12.5KHz	Op 4	Ch6	469.5	1	30.38	Varies	PASS

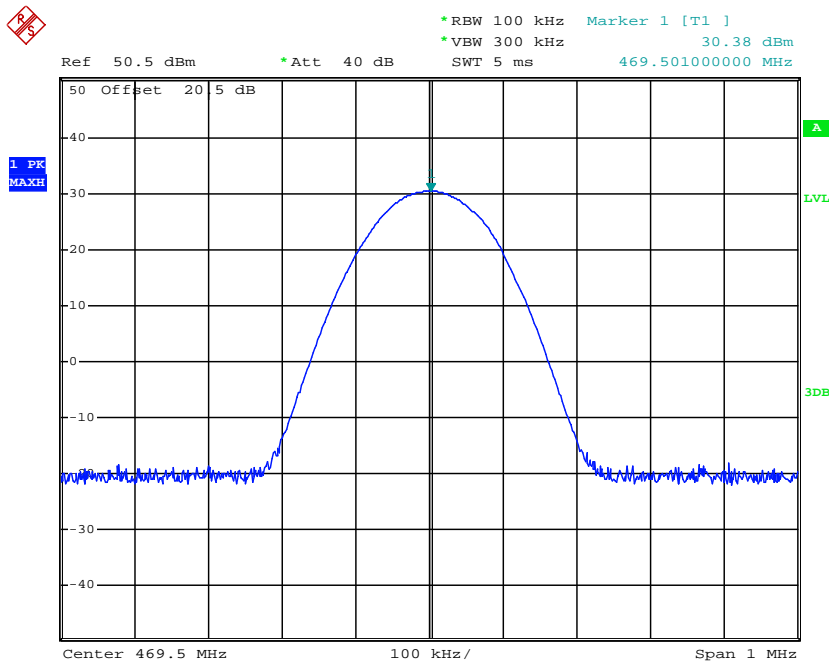

Date: 12.DEC.2013 15:15:31

4.8. Transmitter Frequency Behavior

TEST APPLICABLE

Section 90.214

Transient frequencies must be within the maximum frequency difference limits during the time intervals indicated:

Time intervals ^{1, 2}	Maximum frequency difference ³	All equipment	
		150 to 174 MHz	421 to 512MHz
Transient Frequency Behavior for Equipment Designed to Operate on 25 KHz Channels			
t_1 ⁴	± 25.0 KHz	5.0 ms	10.0 ms
t_2	± 12.5 KHz	20.0 ms	25.0 ms
t_3 ⁴	± 25.0 KHz	5.0 ms	10.0 ms
Transient Frequency Behavior for Equipment Designed to Operate on 12.5 KHz Channels			
t_1 ⁴	± 12.5 KHz	5.0 ms	10.0 ms
t_2	± 6.25 KHz	20.0 ms	25.0 ms
t_3 ⁴	± 12.5 KHz	5.0 ms	10.0 ms
Transient Frequency Behavior for Equipment Designed to Operate on 6.25 KHz Channels			
t_1 ⁴	±6.25 KHz	5.0 ms	10.0 ms
t_2	±3.125 KHz	20.0 ms	25.0 ms
t_3 ⁴	±6.25 KHz	5.0 ms	10.0 ms

- t_{on} is the instant when a 1 KHz test signal is completely suppressed, including any capture time due to phasing.
 t_1 is the time period immediately following t_{on} .
 t_2 is the time period immediately following t_1 .
 t_3 is the time period from the instant when the transmitter is turned off until t_{off} .
 t_{off} is the instant when the 1 KHz test signal starts to rise.
- During the time from the end of t_2 to the beginning of t_3 , the frequency difference must not exceed the limits specified in § 90.213.
- Difference between the actual transmitter frequency and the assigned transmitter frequency.
- If the transmitter carrier output power rating is 6 watts or less, the frequency difference during this time period may exceed the maximum frequency difference for this time period.

TEST CONFIGURATION

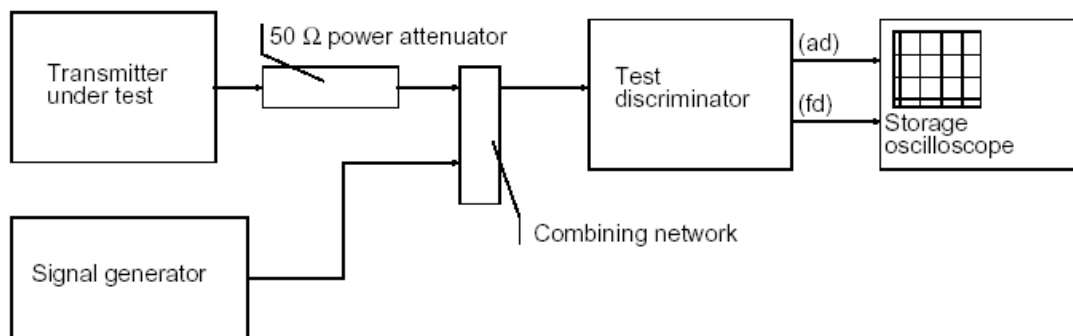

TEST PROCEDURE

According to TIA/EIA-603 2.2.19 requirement.As for the product different from PTT,we use test steps as follows:

- Connect DUT into Test discriminator and Storage Oscilloscope and keep DUT stats ON;
- Inut 1KHz signal into DUT;
- Set the modulation domain analyzer to trigger on the rising edge of the waveform in order to capture a single-shot turn-on of the transmitter signals;
- Keep DUT in OFF state and Key the PTT;
- Observe the stored oscilloscope of modulation domain analyzer.The signal trace shall be maintained within the allowable limits during the periods t_1 and t_2 ,and shall also remain within limits following t_2 ;
- Adjust the modulation domain anzlyzer to trigger on the falling edge of the transmitter waveform in order to capture a single-shot turn-off transmitter of the transmitter signal.
- Keep the digital portable radio in ON state and Unkey the PTT;

- 8. Observe the stored oscilloscope of modulation domain analyzer. The signal trace shall be maintained within the allowable limits during the period t_3 .

TEST RESULTS

Please refer to the following plots.

Modulation Type: FM

Transmitter Frequency Behaviour @ 12.5 KHz Channel Separation-----Off – On

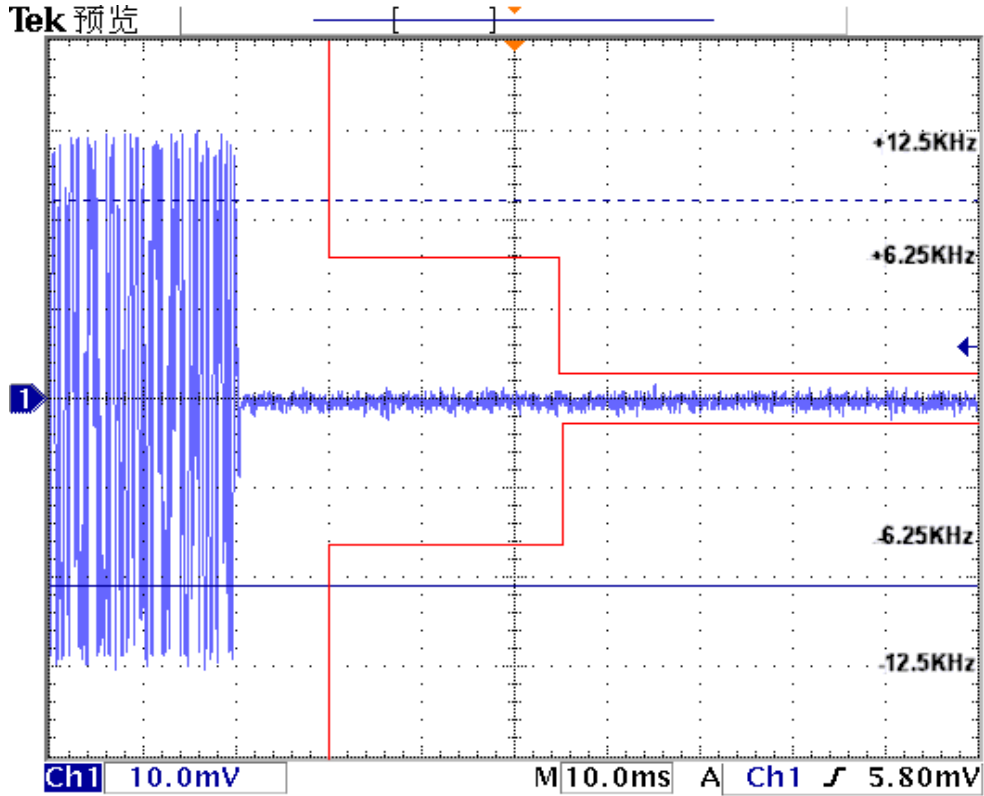

Transmitter Frequency Behaviour @ 12.5 KHz Channel Separation-----On – Off

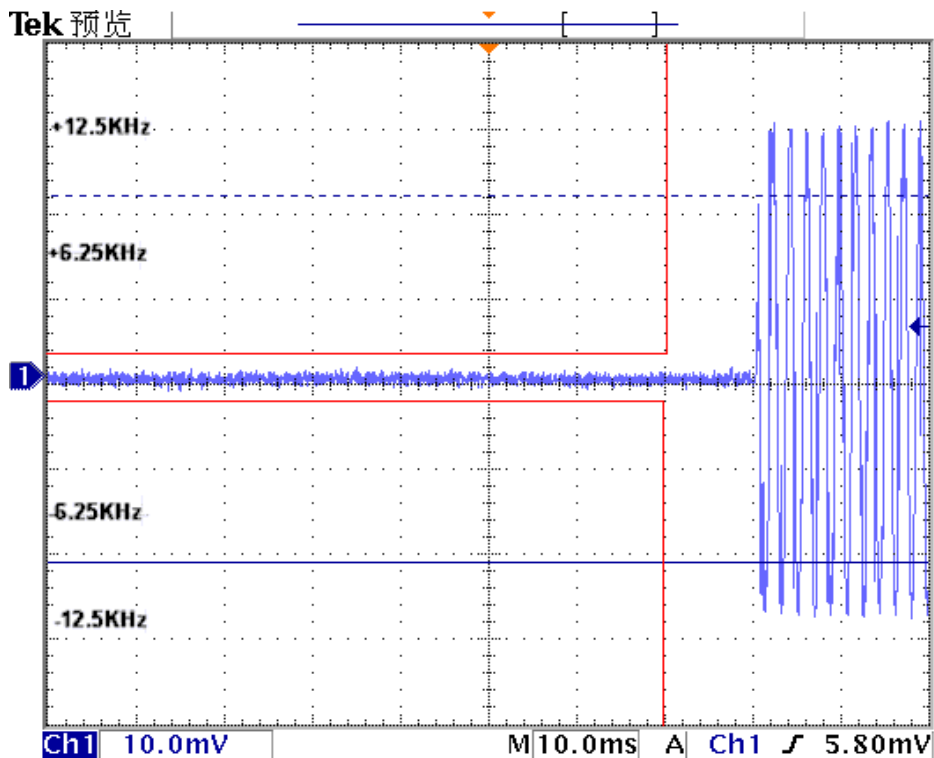

Modulation Type: 4FSK

Transmitter Frequency Behaviour @ 12.5 KHz Channel Separation-----Off – On

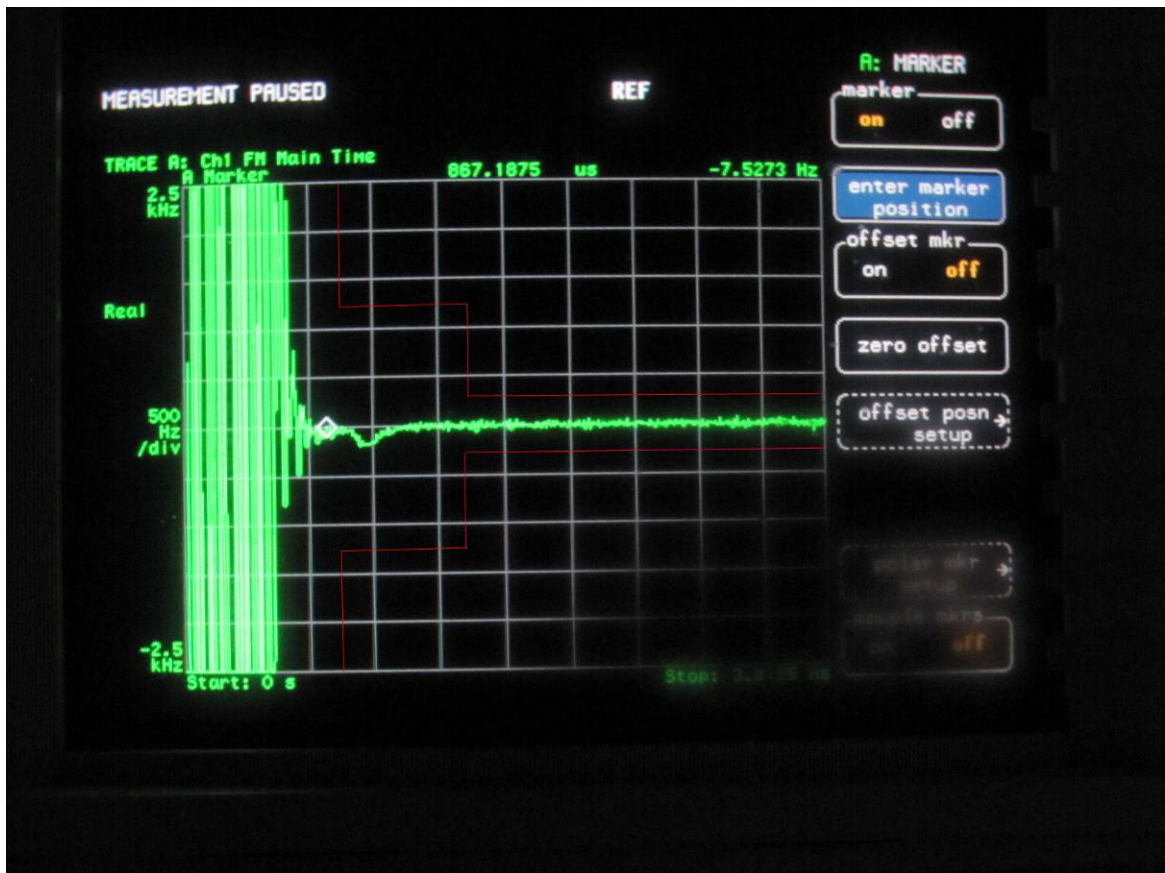

Transmitter Frequency Behaviour @ 12.5 KHz Channel Separation-----On – Off

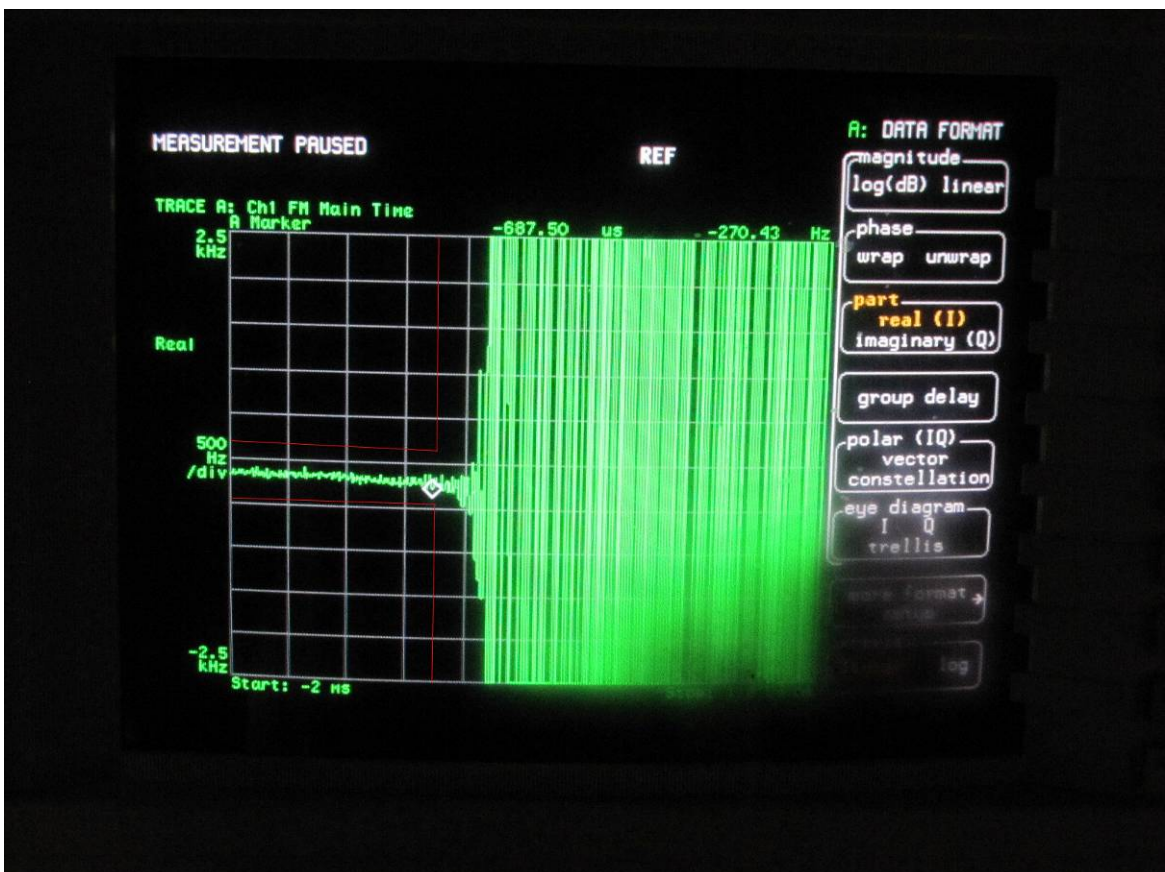

4.9. Receiver Radiated Spurious Emission

TEST APPLICABLE

The field strength is calculated by adding the Antenna Factor and Cable Factor and subtracting the Amplifier Gain and Duty Cycle Correction Factor (if any) from the measured reading. The basic equation with a sample calculation is as follows:

$$FS = RA + AF + CL - AG$$

Where FS = Field Strength	CL = Cable Attenuation Factor (Cable Loss)
RA = Reading Amplitude	AG = Amplifier Gain
AF = Antenna Factor	

TEST CONFIGURATION

(A) Radiated Emission Test Set-Up, Frequency below 1000MHz

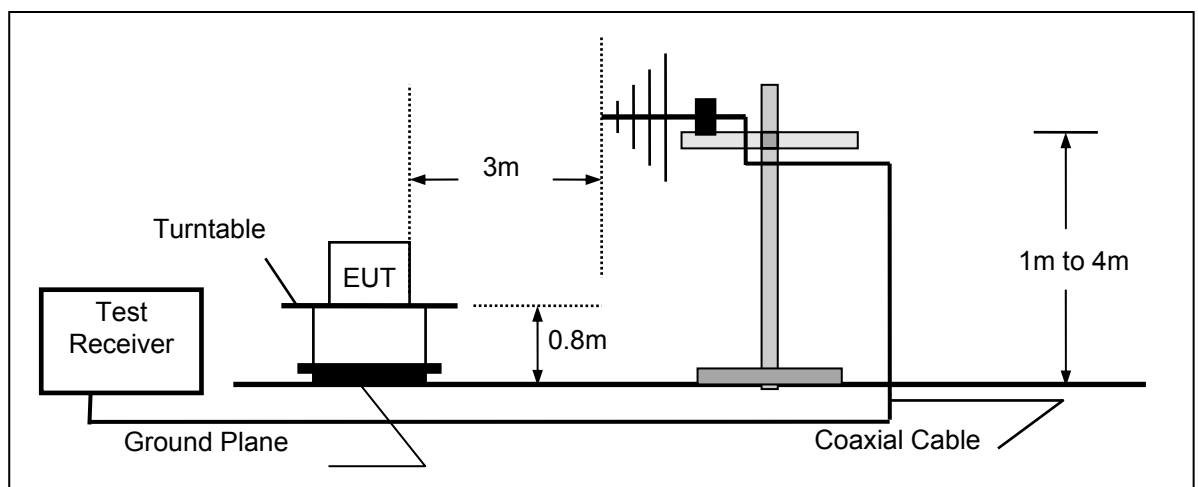

(B) Radiated Emission Test Set-Up, Frequency above 1000MHz

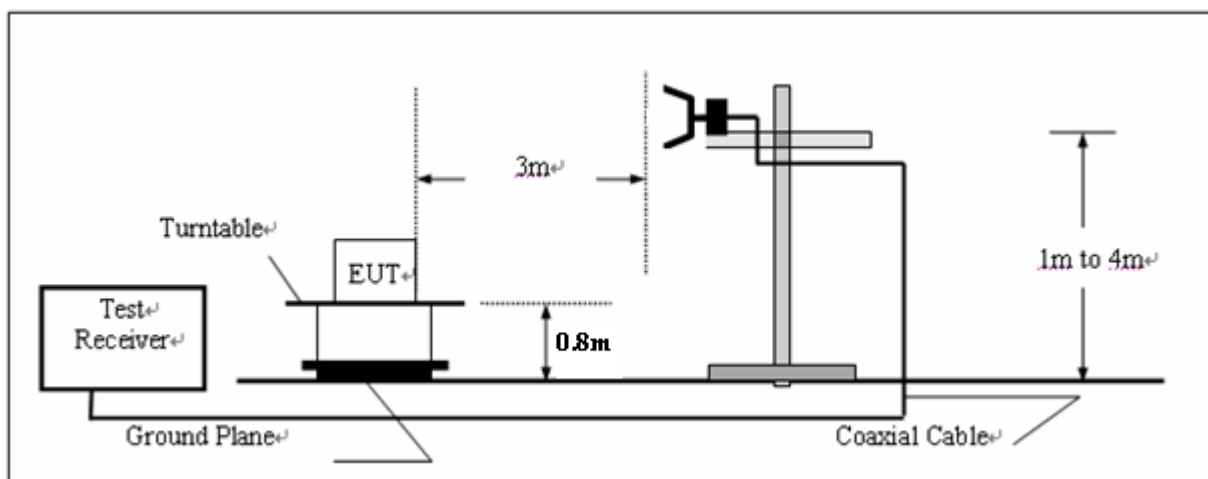

TEST PROCEDURE

- 1 The EUT was placed on a turn table which is 0.8m above ground plane.
- 2 Maximum procedure was performed by raising the receiving antenna from 1m to 4m and rotating the turn table from 0° to 360° to acquire the highest emissions from EUT
- 3 And also, each emission was to be maximized by changing the polarization of receiving antenna both horizontal and vertical.
- 4 Repeat above procedures until all frequency measurements have been completed.

RECEIVER RADIATED SPOUIOUS LIMIT

For unintentional device, according to § 15.109(a) and RSS-Gen, except for Class A digital devices, the field strength of radiated emissions from unintentional radiators at a distance of 3 meters shall not exceed the following values:

Frequency (MHz)	Distance (Meters)	Radiated (dBµV/m)	Radiated (µV/m)
30-88	3	40.0	100
88-216	3	43.5	150
216-960	3	46.0	200
Above 960	3	54.0	500

For intentional device, according to § 15.209(a), the general requirement of field strength of radiated emissions from intentional radiators at a distance of 3 meters shall not exceed the above table.

TEST RESULTS

- Remak: 1.The Radiated Measurement (Standby mode /Receiver mode) are performed to the three channels (the high channel, the middle channel and the low channel), the datum recorded below is the worst case for each channel separation;and the EUT shall be scanned from 30 MHz to the 5th harmonic of the highest oscillator frequency in the digital devices or 1 GHz whichever is higher.
- 2.Test performed at Op 5 , Op 6 operation mode respectively.And the datum append below is the worst case at low channel of each operation mode

Operation Mode	Test Channel	Test Frequency (MHz)	Polar.	Maximum Radiated Emissions		Limit (dBuV/m)
				Frequency (MHz)	Datum (dBuV/m)	
Op 5	Ch 1	406.50	H	952.47	34.80	46.00
			V	45.52	34.50	40.00
Test Results			Compliance			

SWEEP TABLE: "test (30M-1G)"

Short Description: Field Strength
 Start Stop Detector Meas. IF Transducer
 Frequency Frequency Time Bandw.
 30.0 MHz 1.0 GHz MaxPeak Coupled 100 kHz VULB9163

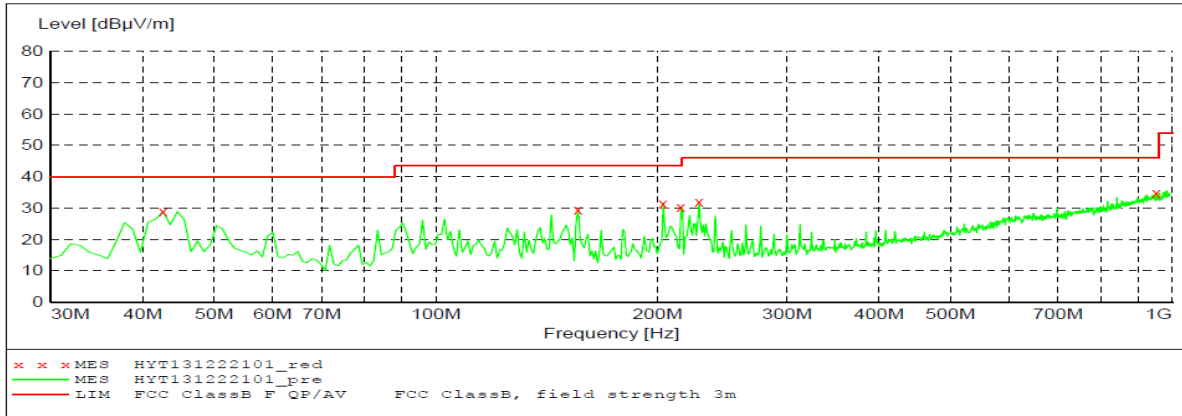

MEASUREMENT RESULT: "HYT131222101_red"

12/23/2013 8:57AM

Frequency MHz	Level dBuV/m	Transd dB	Limit dBuV/m	Margin dB	Det.	Height cm	Azimuth deg	Polarization
42.610000	28.90	-15.0	40.0	11.1	PK	300.0	9.00	HORIZONTAL
156.100000	29.40	-17.8	43.5	14.1	PK	300.0	216.00	HORIZONTAL
203.630000	31.40	-14.7	43.5	12.1	PK	100.0	239.00	HORIZONTAL
215.270000	30.30	-15.0	43.5	13.2	PK	100.0	229.00	HORIZONTAL
227.880000	31.90	-15.1	46.0	14.1	PK	100.0	239.00	HORIZONTAL
952.470000	34.80	3.4	46.0	11.2	PK	100.0	135.00	HORIZONTAL

SWEEP TABLE: "test (30M-1G)"

Short Description: Field Strength
 Start Stop Detector Meas. IF Transducer
 Frequency Frequency Time Bandw.
 30.0 MHz 1.0 GHz MaxPeak Coupled 100 kHz VULB9163

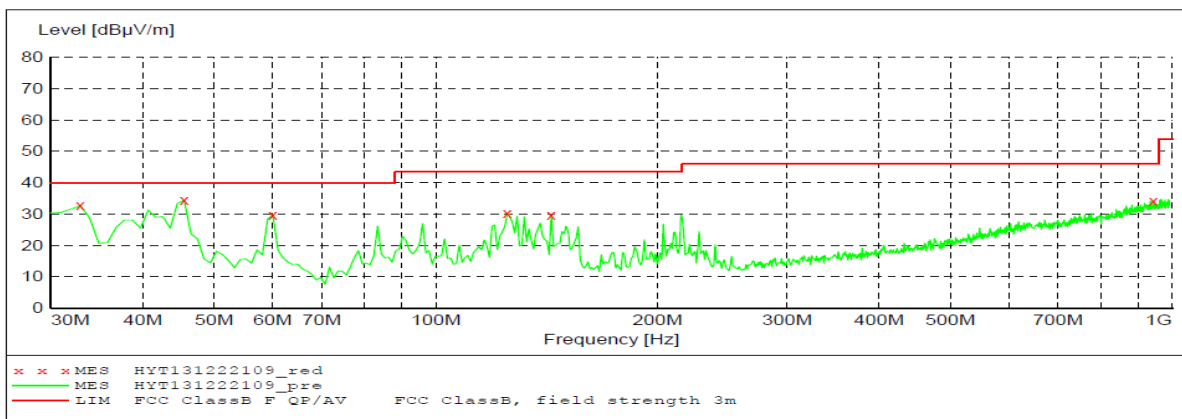

MEASUREMENT RESULT: "HYT131222109_red"

12/23/2013 9:24AM

Frequency MHz	Level dBuV/m	Transd dB	Limit dBuV/m	Margin dB	Det.	Height cm	Azimuth deg	Polarization
32.910000	32.70	-16.3	40.0	7.3	PK	100.0	250.00	VERTICAL
45.520000	34.50	-15.0	40.0	5.5	PK	100.0	117.00	VERTICAL
60.070000	29.80	-15.7	40.0	10.2	PK	100.0	279.00	VERTICAL
125.060000	30.30	-17.2	43.5	13.2	PK	100.0	250.00	VERTICAL
143.490000	29.80	-18.4	43.5	13.7	PK	100.0	220.00	VERTICAL
942.770000	34.20	3.3	46.0	11.8	PK	100.0	307.00	VERTICAL

Operation Mode	Test Channel	Test Frequency (MHz)	Polar.	Maximum Radiated Emissions		Limit (dBuV/m)
				Frequency (MHz)	Datum (dBuV/m)	
Op 5	Ch 1	406.50	H	3588.65	40.25	54.00
			V	4030.03	41.58	54.00
Test Results			Compliance			

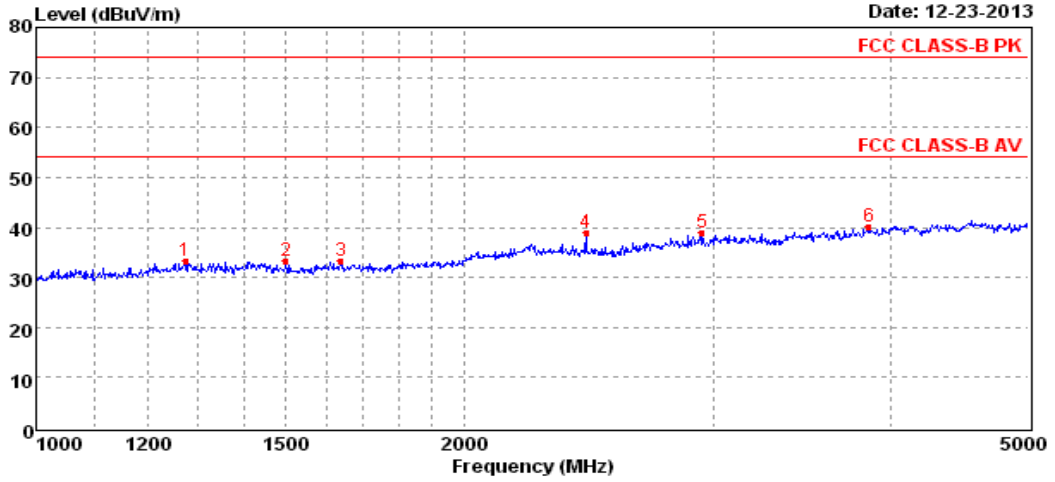

Mark	Frequency MHz	Level dBuV/m	Factor dB	Reading dBuV/m	Limit dBuV/m	Margin dB	Polarization	Det.
1	1273.05	33.44	-8.20	41.64	74.00	40.56	HORIZONTAL	Peak
2	1500.17	33.29	-8.35	41.64	74.00	40.71	HORIZONTAL	Peak
3	1639.02	33.29	-8.38	41.67	74.00	40.71	HORIZONTAL	Peak
4	2439.10	38.95	-5.27	44.22	74.00	35.05	HORIZONTAL	Peak
5	2944.48	38.93	-3.35	42.28	74.00	35.07	HORIZONTAL	Peak
6	3858.65	40.25	-0.98	41.23	74.00	33.75	HORIZONTAL	Peak

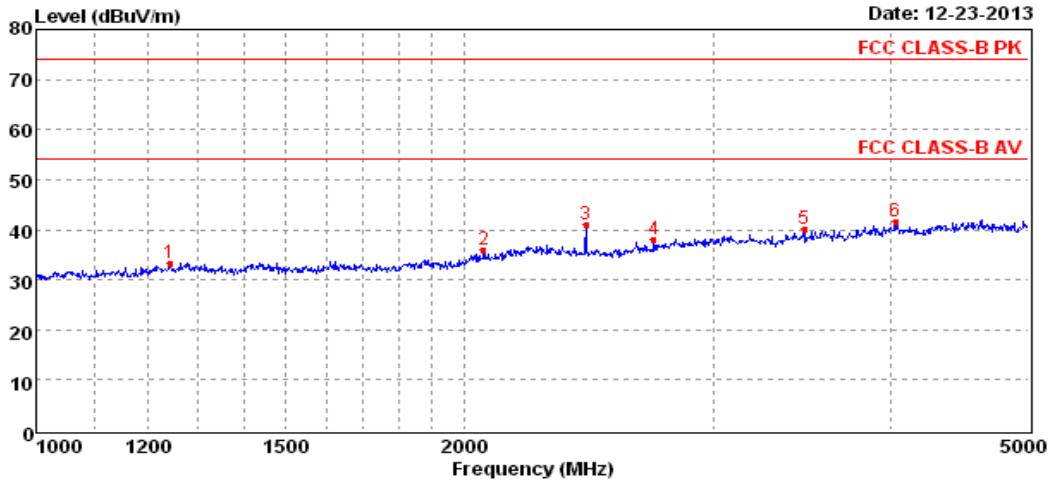

Mark	Frequency MHz	Level dBuV/m	Factor dB	Reading dBuV/m	Limit dBuV/m	Margin dB	Polarization	Det.
1	1242.69	33.43	-8.48	41.91	74.00	40.57	VERTICAL	Peak
2	2066.50	36.03	-6.30	42.33	74.00	37.97	VERTICAL	Peak
3	2439.10	41.08	-5.27	46.35	74.00	32.92	VERTICAL	Peak
4	2725.58	38.07	-4.19	42.26	74.00	35.93	VERTICAL	Peak
5	3475.38	40.27	-2.39	42.66	74.00	33.73	VERTICAL	Peak
6	4030.03	41.58	-0.34	41.92	74.00	32.42	VERTICAL	Peak

Operation Mode	Test Channel	Test Frequency (MHz)	Polar.	Maximum Radiated Emissions		Limit (dBuV/m)
				Frequency (MHz)	Datum (dBuV/m)	
Op 6	Ch 4	406.50	H	957.32	33.90	46.00
			V	943.74	34.20	46.00
Test Results			Compliance			

SWEEP TABLE: "test (30M-1G)"

Short Description: Field Strength
 Start Stop Detector Meas. IF Transducer
 Frequency Frequency Time Bandw.
 30.0 MHz 1.0 GHz MaxPeak Coupled 100 kHz VULB9163

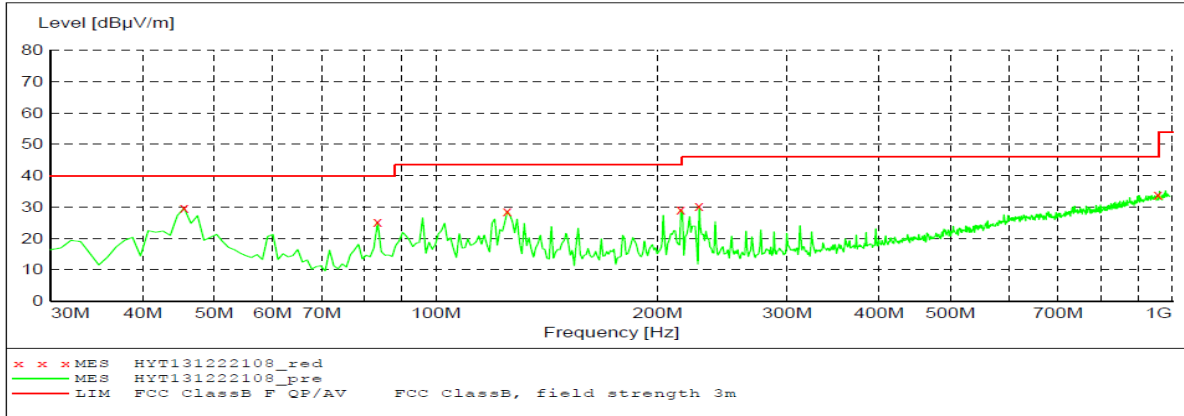

MEASUREMENT RESULT: "HYT131222108_red"

12/23/2013 9:21AM

Frequency MHz	Level dBuV/m	Transd dB	Limit dBuV/m	Margin dB	Det.	Height cm	Azimuth deg	Polarization
45.520000	29.70	-15.0	40.0	10.3	PK	300.0	182.00	HORIZONTAL
83.350000	25.20	-17.9	40.0	14.8	PK	300.0	182.00	HORIZONTAL
125.060000	28.70	-17.2	43.5	14.8	PK	300.0	224.00	HORIZONTAL
215.270000	29.10	-15.0	43.5	14.4	PK	100.0	241.00	HORIZONTAL
227.880000	30.40	-15.1	46.0	15.6	PK	100.0	49.00	HORIZONTAL
957.320000	33.90	3.5	46.0	12.1	PK	300.0	237.00	HORIZONTAL

SWEEP TABLE: "test (30M-1G)"

Short Description: Field Strength
 Start Stop Detector Meas. IF Transducer
 Frequency Frequency Time Bandw.
 30.0 MHz 1.0 GHz MaxPeak Coupled 100 kHz VULB9163

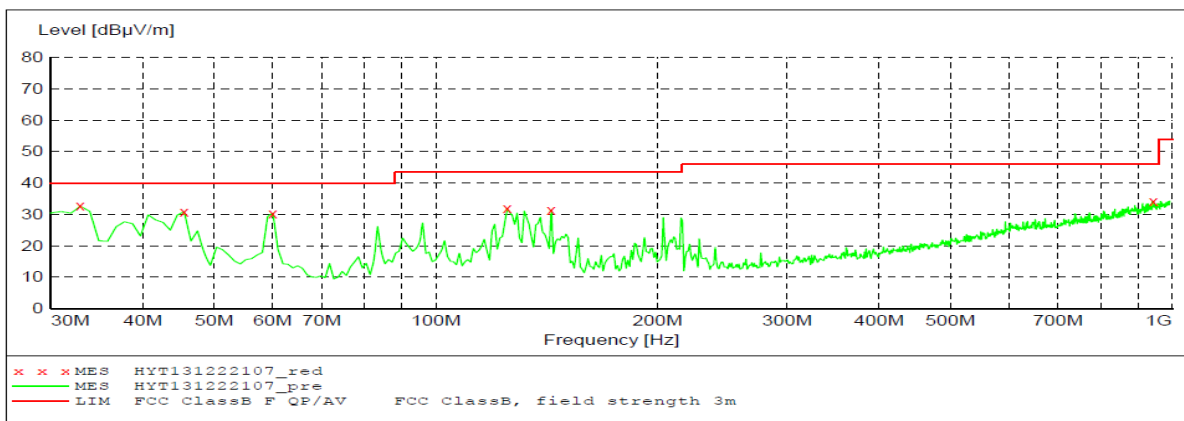

MEASUREMENT RESULT: "HYT131222107_red"

12/23/2013 9:18AM

Frequency MHz	Level dBuV/m	Transd dB	Limit dBuV/m	Margin dB	Det.	Height cm	Azimuth deg	Polarization
32.910000	32.70	-16.3	40.0	7.3	PK	100.0	247.00	VERTICAL
45.520000	30.90	-15.0	40.0	9.1	PK	100.0	119.00	VERTICAL
60.070000	30.40	-15.7	40.0	9.6	PK	100.0	289.00	VERTICAL
125.060000	32.00	-17.2	43.5	11.5	PK	100.0	260.00	VERTICAL
143.490000	31.50	-18.4	43.5	12.0	PK	100.0	235.00	VERTICAL
943.740000	34.20	3.3	46.0	11.8	PK	100.0	192.00	VERTICAL

Operation Mode	Test Channel	Test Frequency (MHz)	Polar.	Maximum Radiated Emissions		IC Limit (dBuV/m)
				Frequency (MHz)	Datum (dBuV/m)	
Op 6	Ch 4	406.50	H	2439.10	40.81	54.00
			V	4479.68	41.44	54.00
Test Results			Compliance			

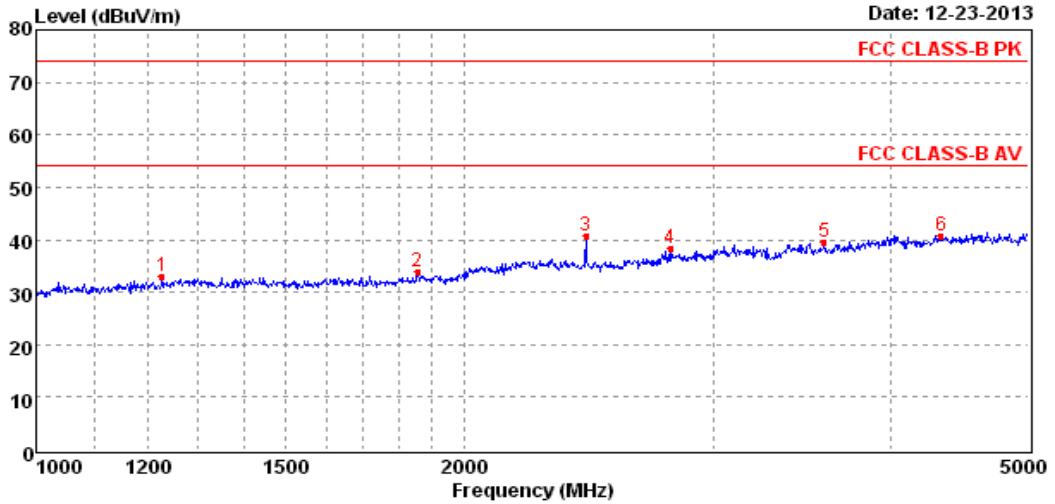

Mark	Frequency MHz	Level dBuV/m	Factor dB	Reading dBuV/m	Limit dBuV/m	Margin dB	Polarization	Det.
1	1226.79	33.14	-8.63	41.77	74.00	40.86	HORIZONTAL	Peak
2	1855.26	33.83	-8.01	41.84	74.00	40.17	HORIZONTAL	Peak
3	2439.10	40.81	-5.27	46.08	74.00	33.19	HORIZONTAL	Peak
4	2796.67	38.22	-3.83	42.05	74.00	35.78	HORIZONTAL	Peak
5	3589.07	39.61	-1.81	41.42	74.00	34.39	HORIZONTAL	Peak
6	4339.71	40.79	0.71	40.08	74.00	33.21	HORIZONTAL	Peak

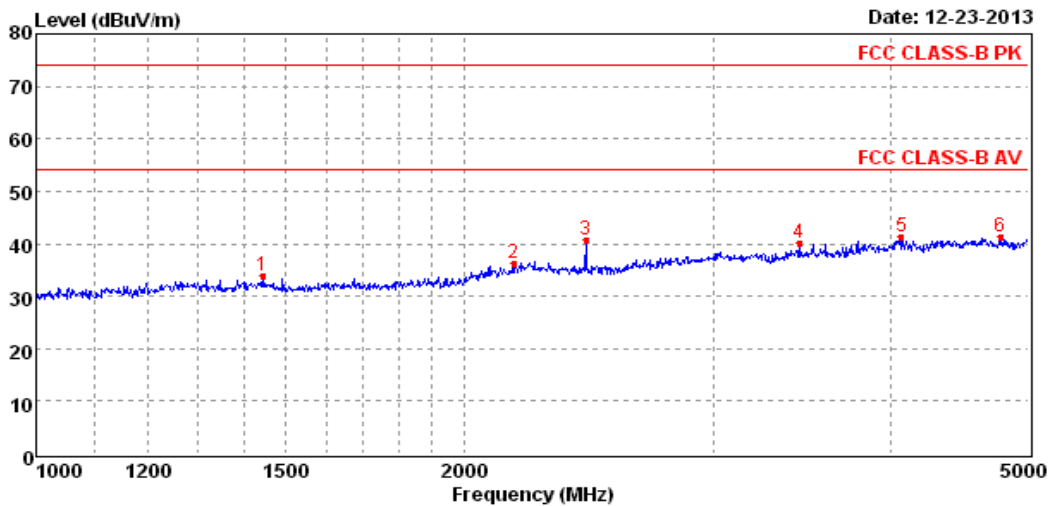

Mark	Frequency MHz	Level dBuV/m	Factor dB	Reading dBuV/m	Limit dBuV/m	Margin dB	Polarization	Det.
1	1443.33	34.00	-8.20	42.20	74.00	40.00	VERTICAL	Peak
2	2168.73	36.22	-5.23	41.45	74.00	37.78	VERTICAL	Peak
3	2439.10	40.85	-5.27	46.12	74.00	33.15	VERTICAL	Peak
4	3447.53	40.06	-2.60	42.66	74.00	33.94	VERTICAL	Peak
5	4069.13	41.42	-0.14	41.56	74.00	32.58	VERTICAL	Peak
6	4779.68	41.44	2.06	39.38	74.00	32.56	VERTICAL	Peak

4.10. Receiver Conducted Spurious Emission

TEST APPLICABLE

The same as Section 4.3

TEST PROCEDURE

The spectrum analyzer was connected to the RF output power of the EUT, the EUT was setup in receiving mode; The RBW of the spectrum analyzer was set to 100 kHz and the VBW set to 300 KHz below the test frequency 1GHz. While the RBW of the spectrum analyzer was set to the 1MHz and VBW set to the 3MHz from 1GHz to the 10th harmonic.

TEST CONFIGURATION

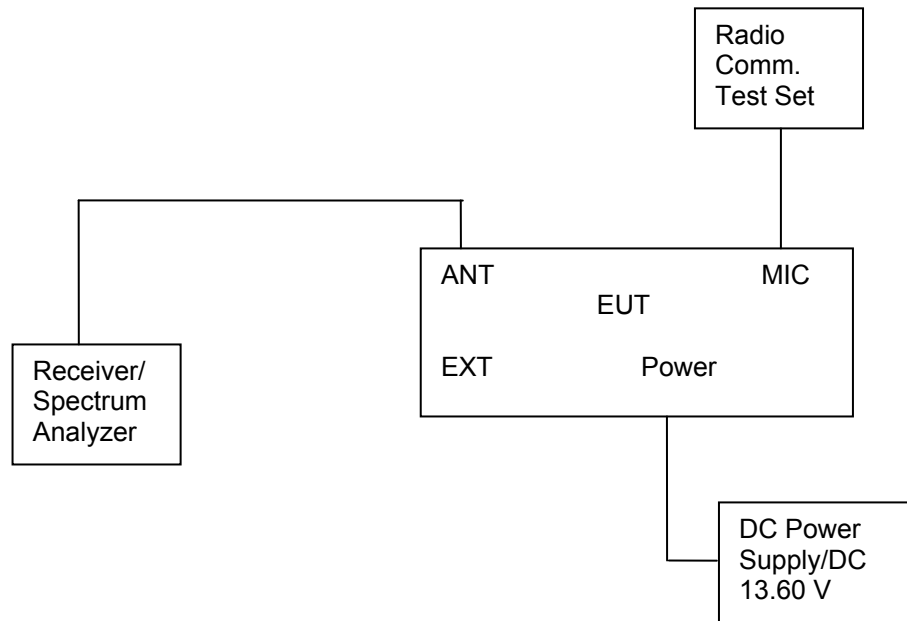

LIMIT

The power at the antenna terminal shall not exceed 2.0 nanowatts (-57dBm).

TEST RESULTS

The Receiver Conducted Spurious Emissions Measurement is performed to the five channels (the top channel, the middle channel and the bottom channel), the datums recorded below were for the five channels; and the EUT shall be scanned from 30 MHz to the 5GHz.

Operation Mode	Test Channel	Test Frequency (MHz)	Maximum Conducted Spurious Emissions Below 1GHz		Maximum Conducted Spurious Emissions Above 1GHz	
			Frequency (MHz)	Datum (dBm)	Frequency (MHz)	Datum (dBm)
Op 5	Ch1	406.5	348.16	-69.90	1736.00	-69.65
	Ch2	435.0	377.26	-65.75	1880.00	-70.38
	Ch3	469.5	412.18	-60.83	2472.00	-66.49
Op 6	Ch4	406.5	348.16	-70.01	1736.00	-69.90
	Ch5	435.0	377.26	-65.79	1880.00	-69.42
	Ch6	469.5	412.18	-60.68	2472.00	-66.13
Limit			-57dBm for 12.5KHz Channel Separation			
Test Results			PASS			

Plots of Receiver Spurious Emission on Antenna Port Measurement

Operation Mode	Test Channel	Test Frequency (MHz)	Maximum Conducted Spurious Emissions Below 1GHz		Maximum Conducted Spurious Emissions Above 1GHz		Limit (dBm)
			Frequency (MHz)	Datum (dBm)	Frequency (MHz)	Datum (dBm)	
Op 5	Ch1	406.50	348.16	-69.90	1736.00	-69.65	-57.00

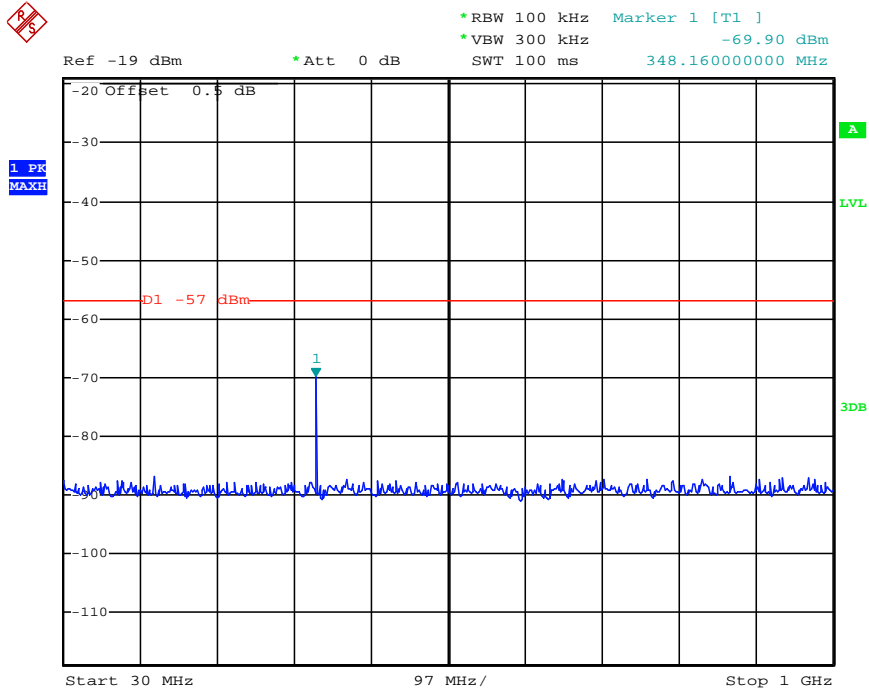

Date: 16.DEC.2013 15:58:57

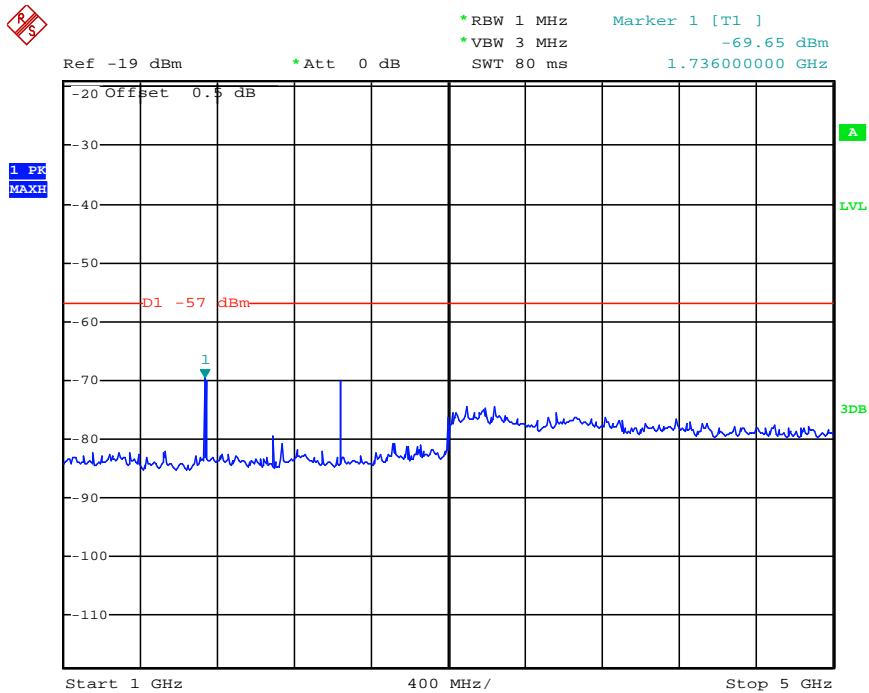

Date: 16.DEC.2013 16:05:46

Operation Mode	Test Channel	Test Frequency (MHz)	Maximum Conducted Spurious Emissions Below 1GHz		Maximum Conducted Spurious Emissions Above 1GHz		Limit (dBm)
			Frequency (MHz)	Datum (dBm)	Frequency (MHz)	Datum (dBm)	
Op 5	Ch2	435.00	377.26	-65.75	1880.00	-70.38	-57.00

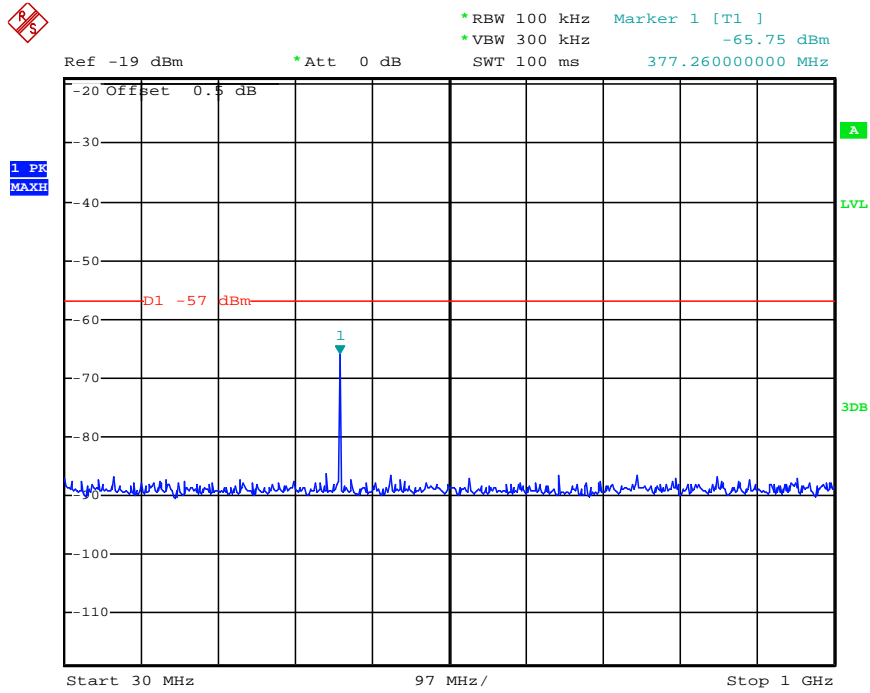

Date: 16.DEC.2013 15:59:38

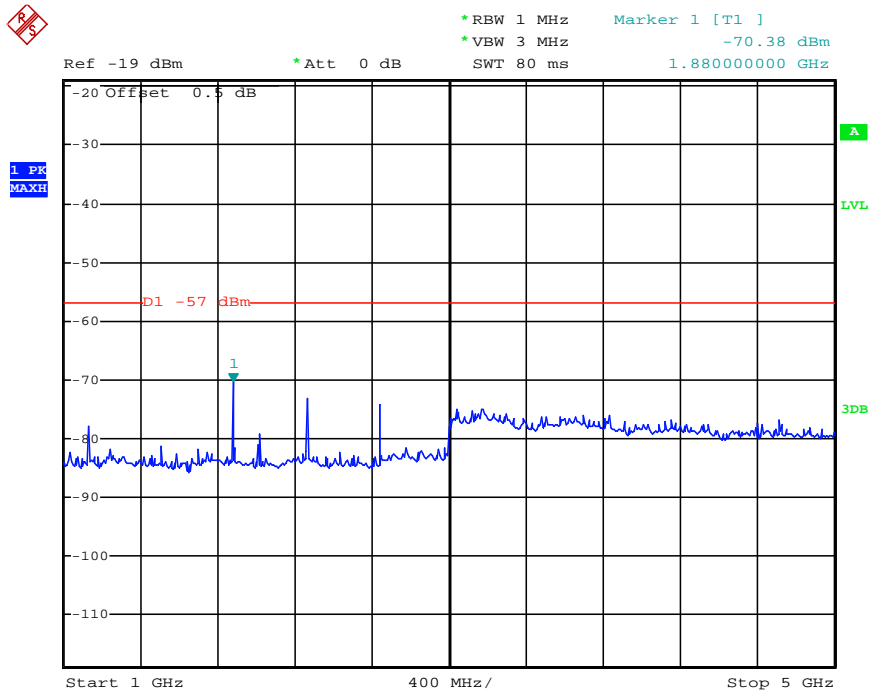

Date: 16.DEC.2013 16:06:23

Operation Mode	Test Channel	Test Frequency (MHz)	Maximum Conducted Spurious Emissions Below 1GHz		Maximum Conducted Spurious Emissions Above 1GHz		Limit (dBm)
			Frequency (MHz)	Datum (dBm)	Frequency (MHz)	Datum (dBm)	
Op 5	Ch3	469.50	412.18	-60.83	2472.00	-66.49	-57.00

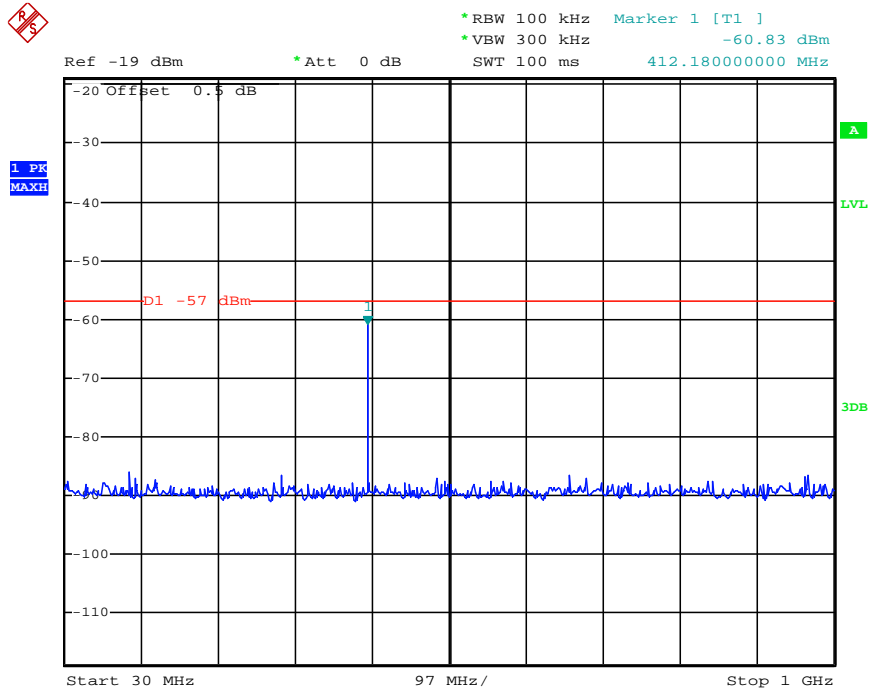

Date: 16.DEC.2013 16:00:19

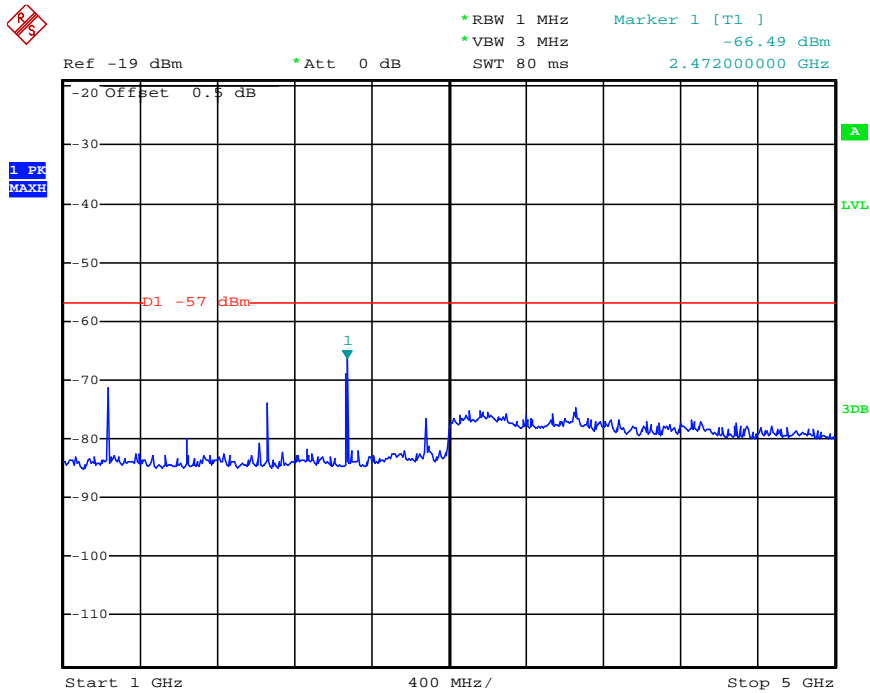

Date: 16.DEC.2013 16:06:57

Operation Mode	Test Channel	Test Frequency (MHz)	Maximum Conducted Spurious Emissions Below 1GHz		Maximum Conducted Spurious Emissions Above 1GHz		Limit (dBm)
			Frequency (MHz)	Datum (dBm)	Frequency (MHz)	Datum (dBm)	
Op 6	Ch4	406.50	348.16	-70.01	1736.00	-69.90	-57.00

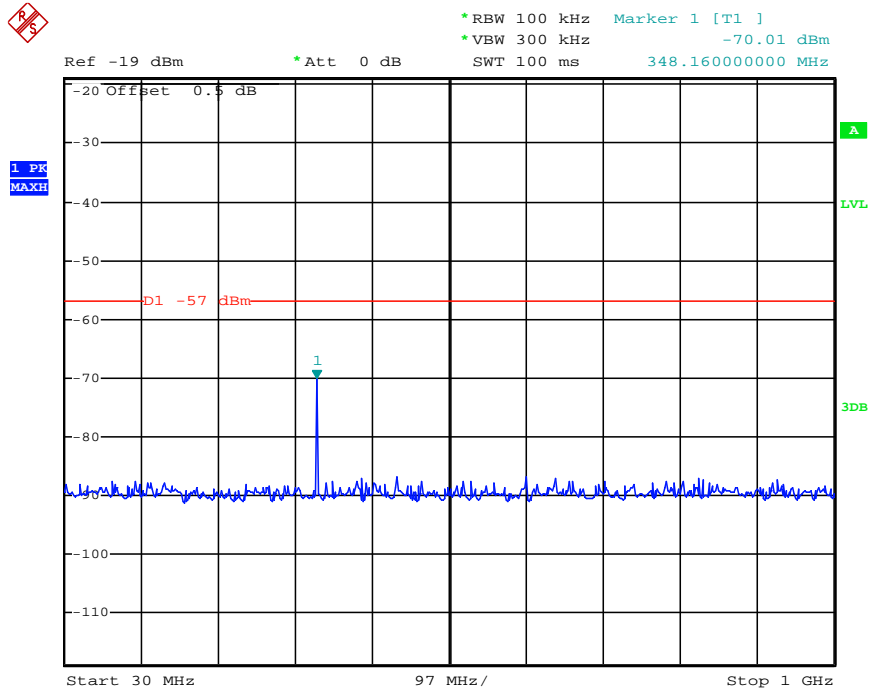

Date: 16.DEC.2013 16:02:23

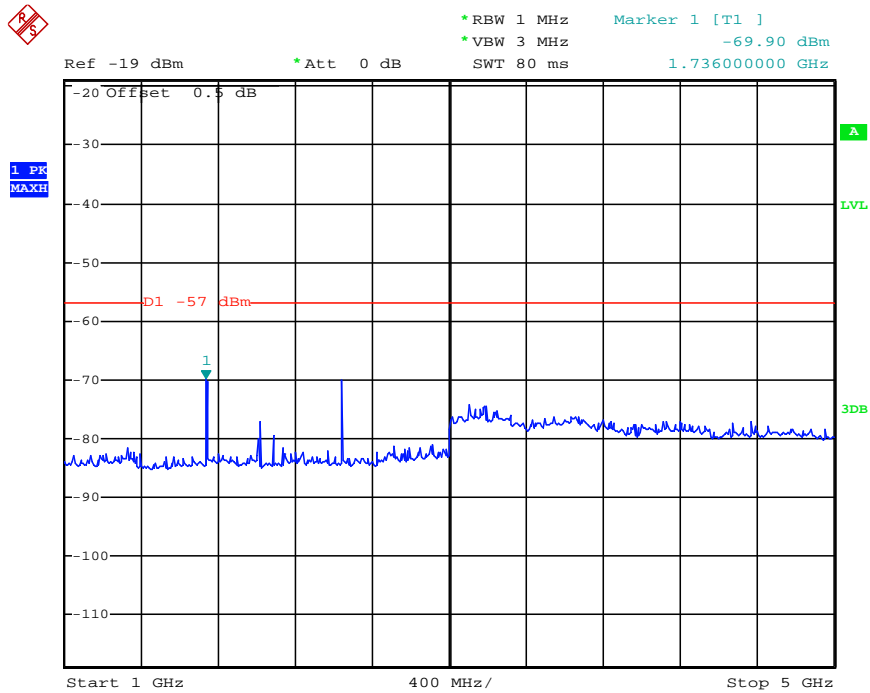

Date: 16.DEC.2013 16:05:20

Operation Mode	Test Channel	Test Frequency (MHz)	Maximum Conducted Spurious Emissions Below 1GHz		Maximum Conducted Spurious Emissions Above 1GHz		Limit (dBm)
			Frequency (MHz)	Datum (dBm)	Frequency (MHz)	Datum (dBm)	
Op 6	Ch5	435.00	377.26	-65.79	1880.00	-69.42	-57.00

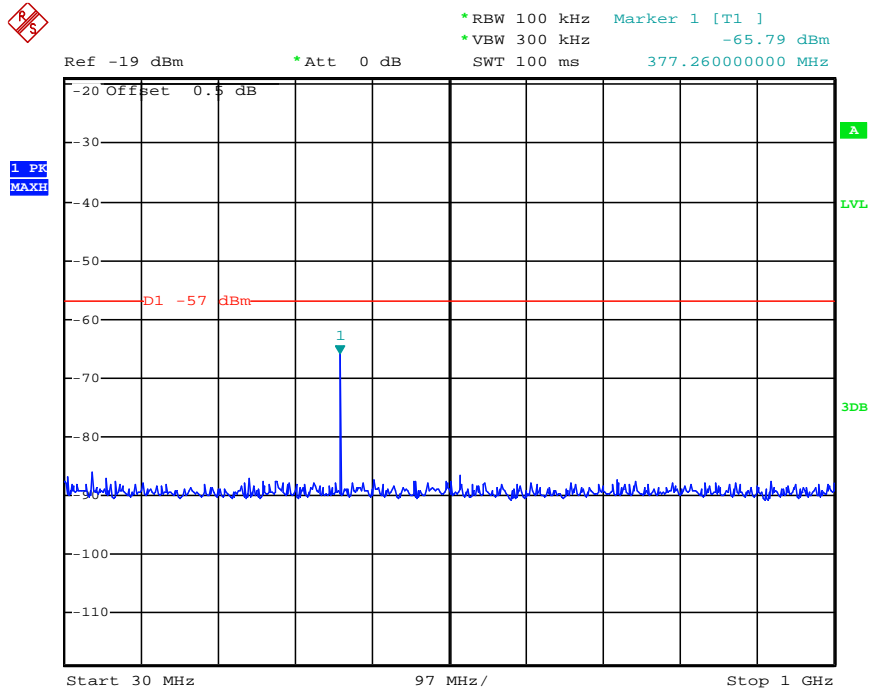

Date: 16.DEC.2013 16:03:04

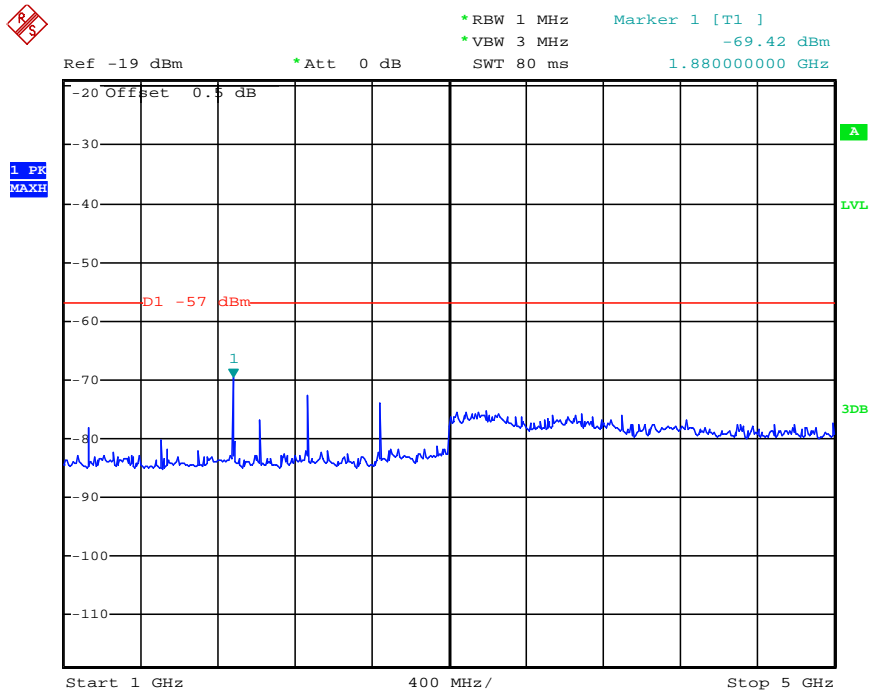

Date: 16.DEC.2013 16:04:46

Operation Mode	Test Channel	Test Frequency (MHz)	Maximum Conducted Spurious Emissions Below 1GHz		Maximum Conducted Spurious Emissions Above 1GHz		Limit (dBm)
			Frequency (MHz)	Datum (dBm)	Frequency (MHz)	Datum (dBm)	
Op 6	Ch6	469.50	412.18	-60.68	2472.00	-66.13	-57.00

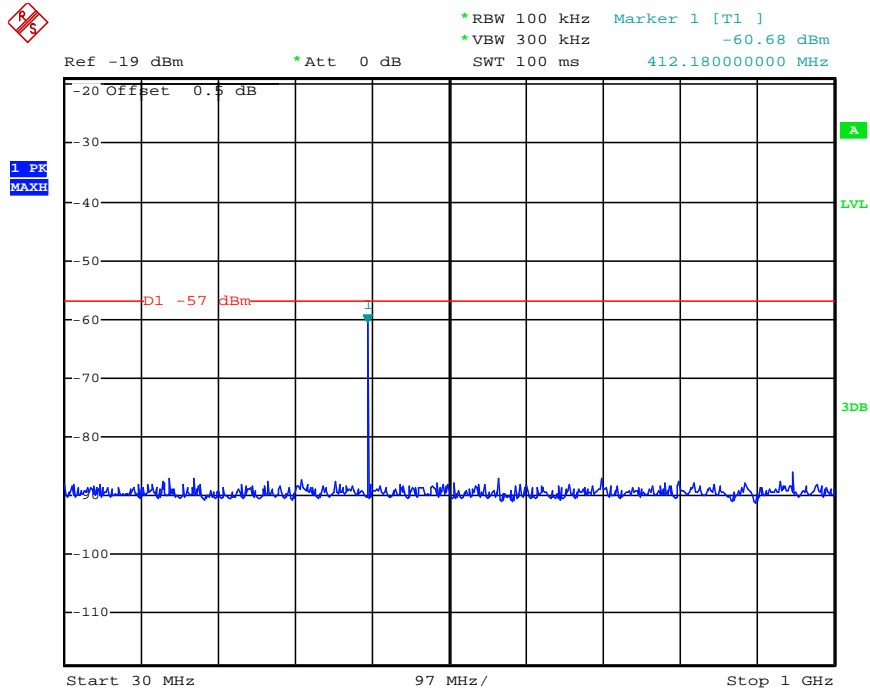

Date: 16.DEC.2013 16:03:38

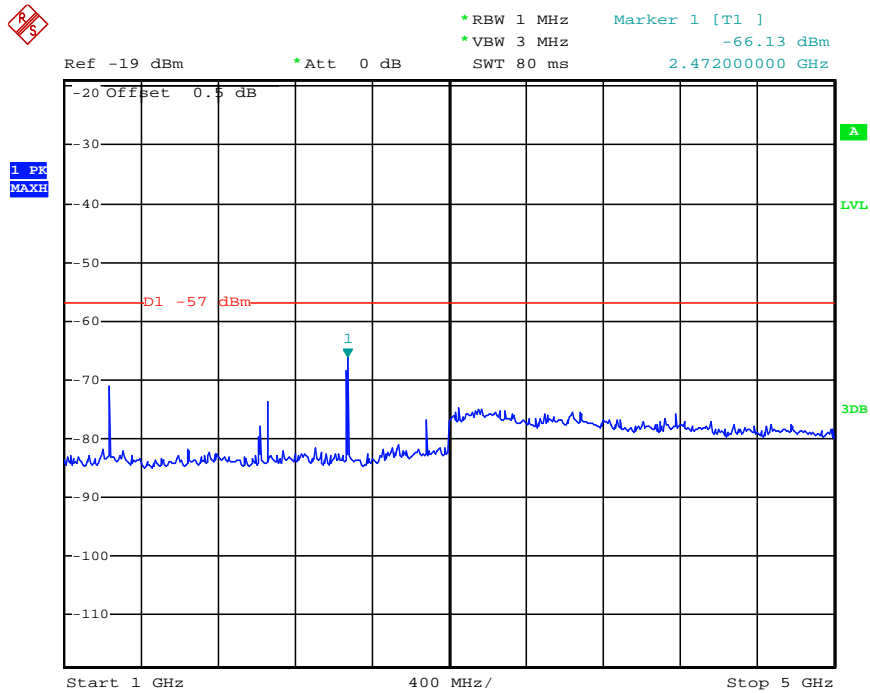

Date: 16.DEC.2013 16:04:05

5. Test Setup Photos of the EUT

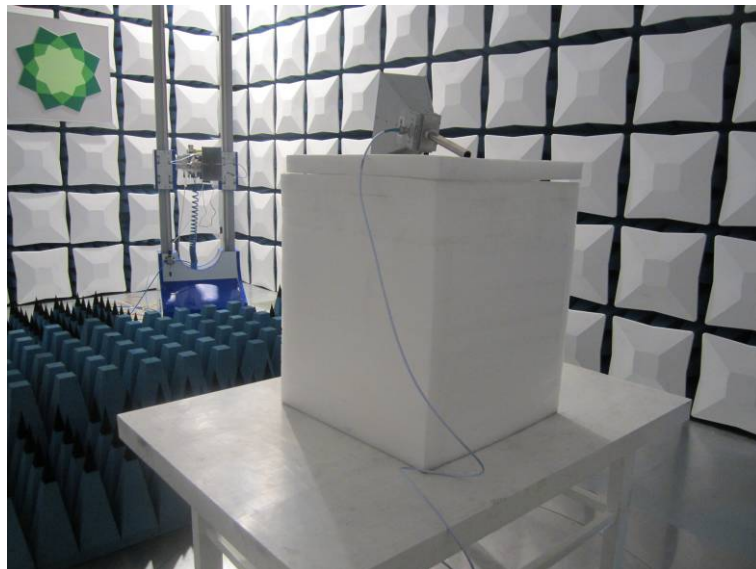

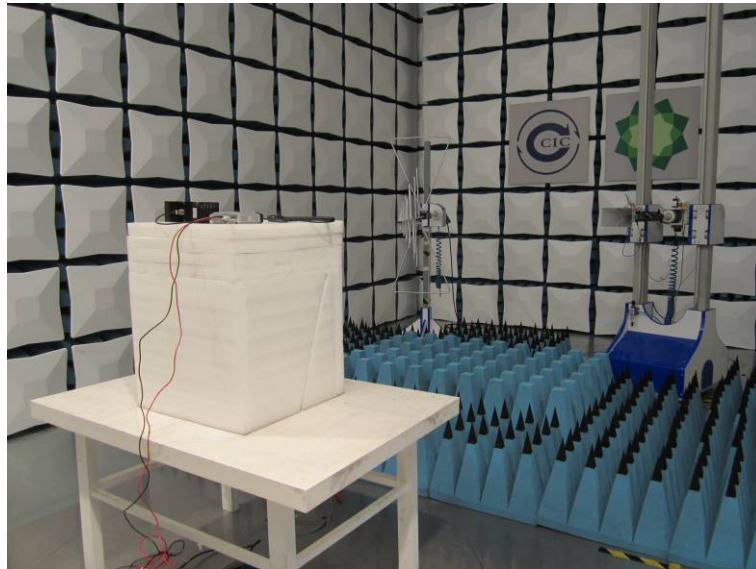



6. External and Internal Photos of the EUT

External photos of the EUT







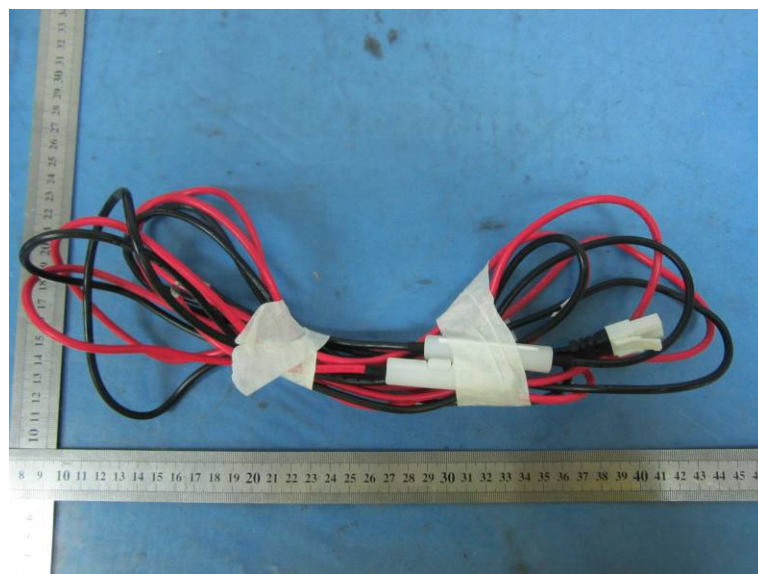

Internal photos of the EUT

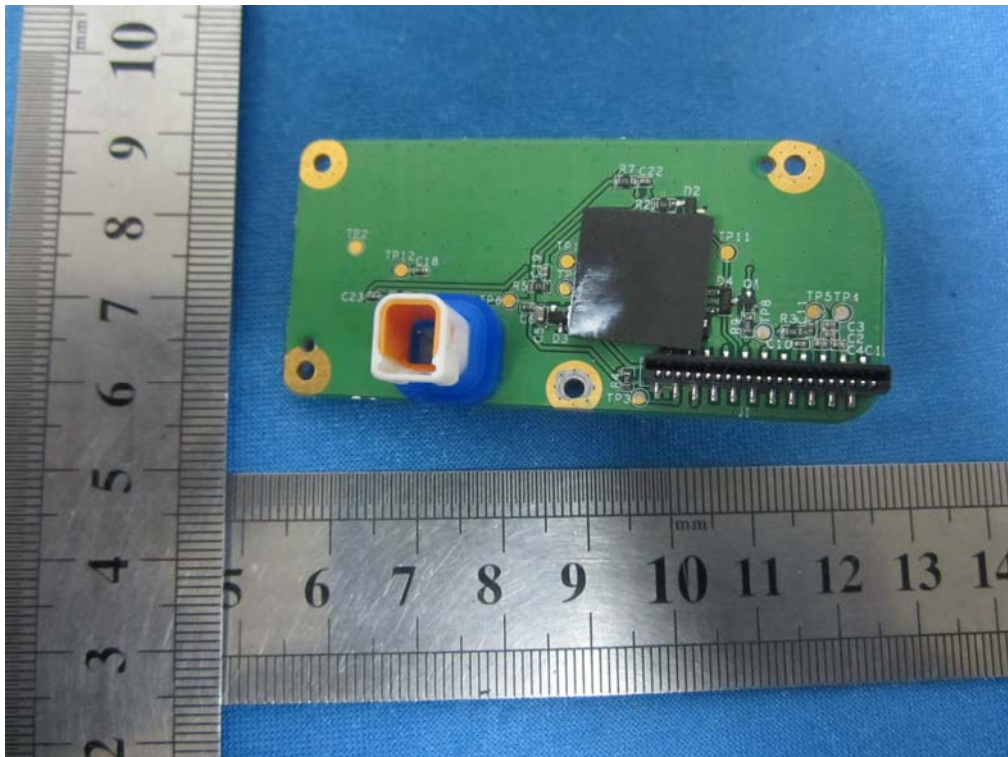

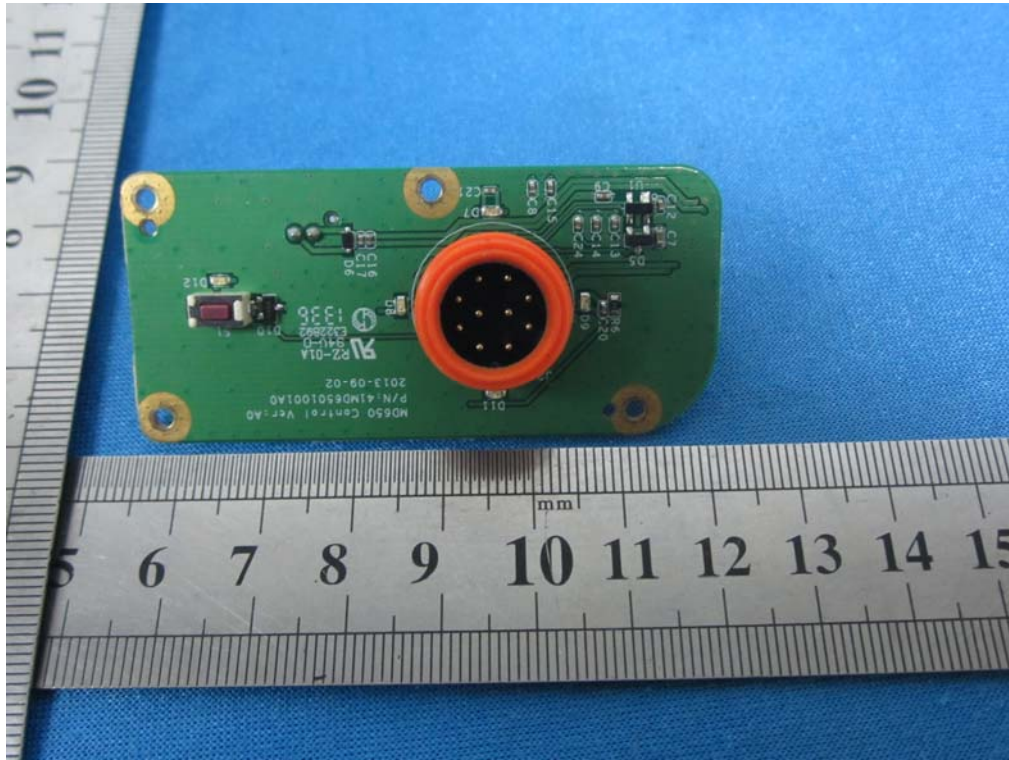

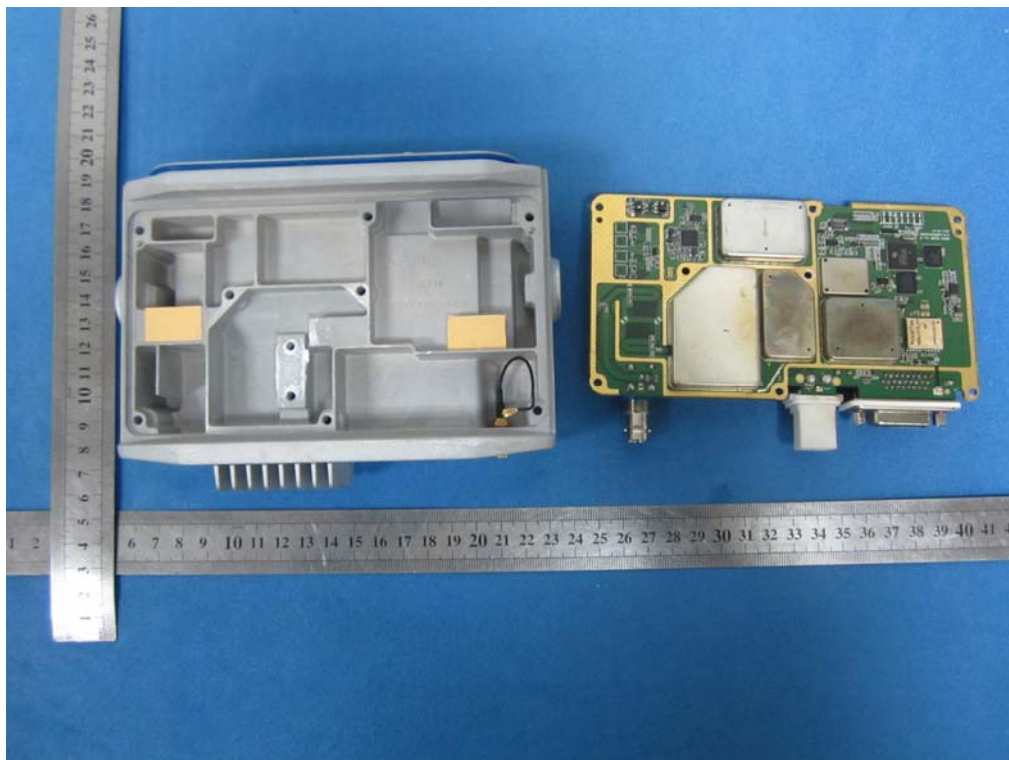

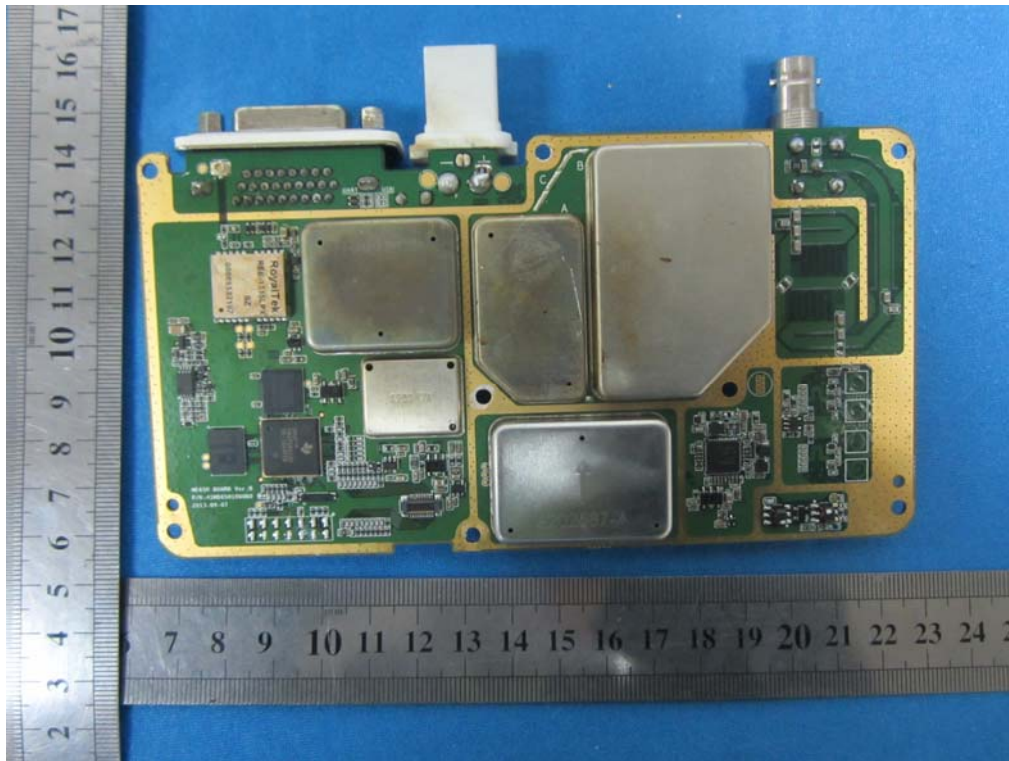
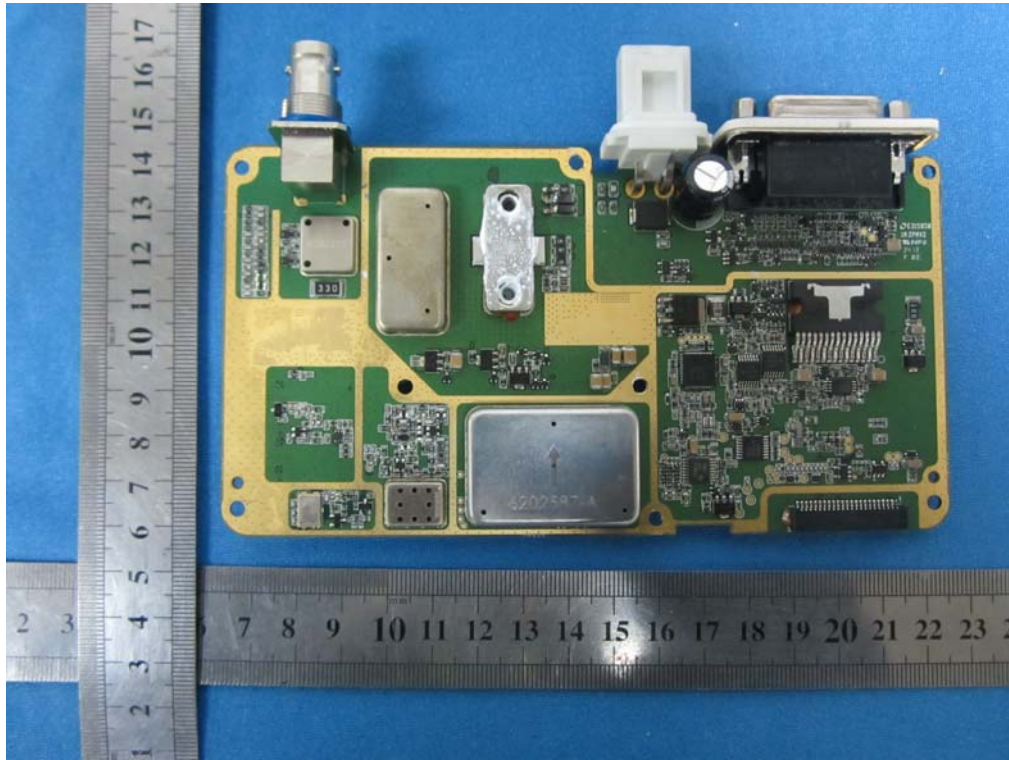



.....End of Report.....