

### 5.9. Transmitter Radiated Spurious Emission

Radiated spurious emissions are emissions from the equipment when transmitting into a nonradiating load on a frequency or frequencies that are outside an occupied band sufficient to ensure transmission of information of required quality for the class of communications desired.

**LIMIT**

Please refer to FCC 47 CFR 2.1051, 2.1057, 74.462(c) for specification details.

Emissions shall be attenuated below the mean output power of the transmitter as follows:

FCC Rules	Attenuation Limit (dBc)
§ 74.462(c)§90.210(b)(3)	At least 43 +10log10 (mean power in watts) dB
§ 74.462(c)§90.210(d)(3)	At least 50 +10log10 (mean power in watts) dB

50 +10 log (Pwatts)

Note: In general, the worse case attenuation requirement shown above was applied.

Calculation: Limit (dBm) =EL-50-10log10 (TP)

EL is the emission level of the Output Power expressed in dBm,

In this application, the EL is P (dBm)

Limit (dBm) = P (dBm)-50-10 log (Pwatts) = -20dBm

43 + 10 log (Pwatts)

Calculation: Limit (dBm) =EL-43-10log10 (TP)

Notes: EL is the emission level of the Output Power expressed in dBm,

In this application, the EL is P (dBm).

Limit (dBm) = P (dBm)-43-10 log (Pwatts) = -13 dBm

**TEST CONFIGURATION**

Below 1GHz:

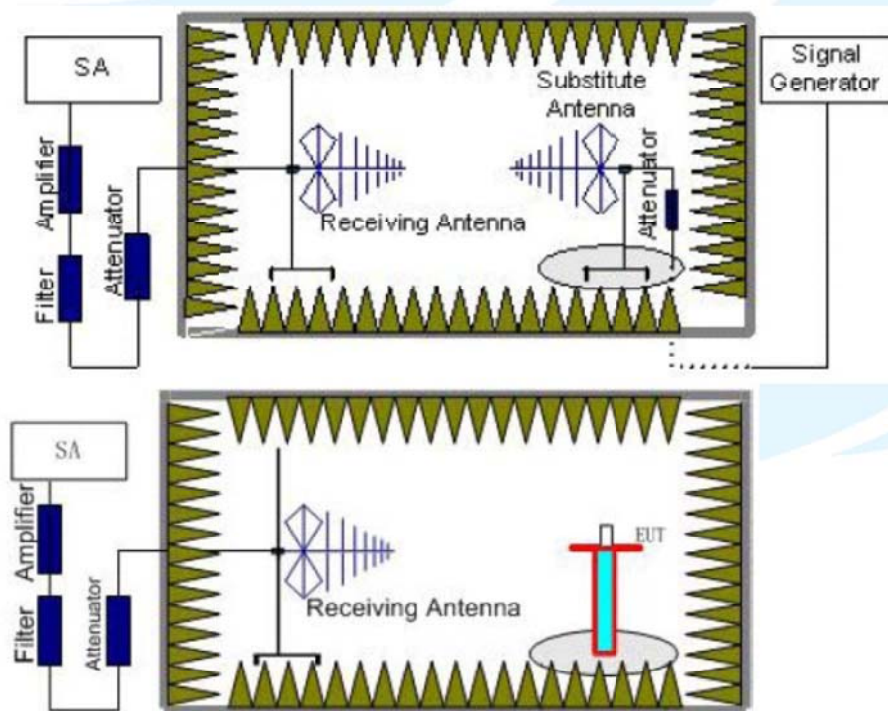

Above 1GHz:

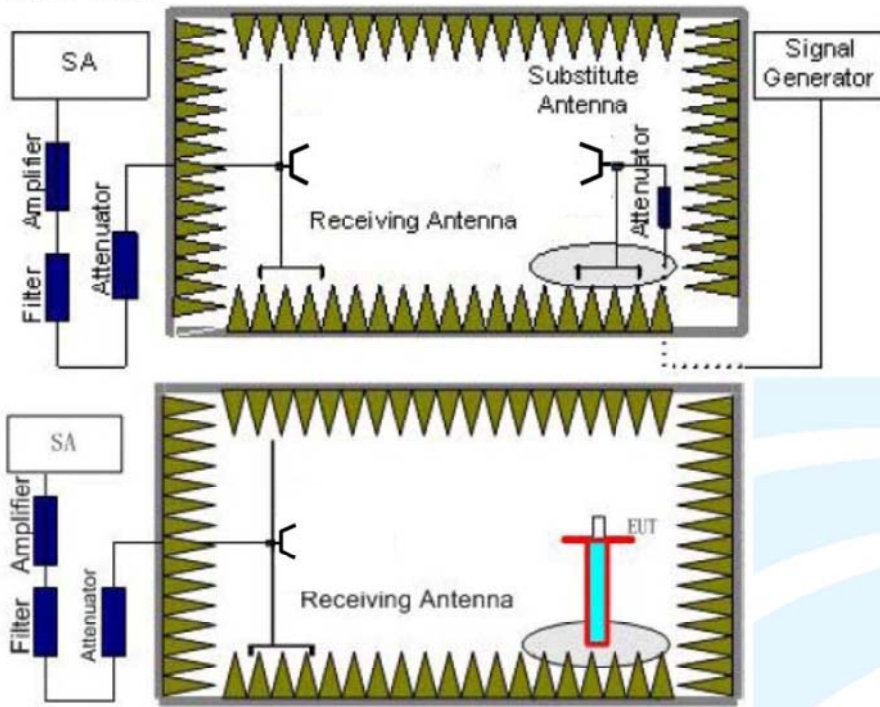

## TEST PROCEDURE

1. Standard Transmitter Load with a  $50\ \Omega$  input impedance and an output impedance matched to the test equipment.
2. EUT was placed on a 0.8 meter high non-conductive stand at a 3 meter test distance from the receive antenna. A receiving antenna was placed on the antenna mast 3 meters from the EUT for emission measurements. The height of receiving antenna is 1.0 m. Detected emissions were maximized at each frequency by rotating the EUT through  $360^\circ$  and adjusting the receiving antenna polarization. The radiated emission measurements of all transmit frequencies in six channels were measured with peak detector.
3. A log-periodic antenna or double-ridged waveguide horn antenna shall be substituted in place of the EUT. The log-periodic antenna will be driven by a signal generator and the level will be adjusted till the same power value on the spectrum analyzer or receiver. The level of the spurious emissions can be calculated through the level of the signal generator, cable loss, the gain of the substitution antenna and the reading of the spectrum analyzer or receiver.
4. The EUT is then put into continuously transmitting mode at its maximum power level during the test. Set Test Receiver or Spectrum RBW=1MHz, VBW=3MHz for above 1GHz and RBW=100kHz, VBW=300kHz for 30MHz to 1GHz, And the maximum value of the receiver should be recorded as (Pr).
5. The EUT shall be replaced by a substitution antenna. In the chamber, an substitution antenna for the frequency band of interest is placed at the reference point of the chamber. An RF Signal source for the frequency band of interest is connected to the substitution antenna with a cable that has been constructed to not interfere with the radiation pattern of the antenna. A power (PMea) is applied to the input of the substitution antenna, and adjust the level of the signal generator output until the value of the receiver reach the previously recorded (Pr). The power of signal source (PMea) is recorded. The test should be performed by rotating the test item and adjusting the receiving antenna polarization.
6. A amplifier should be connected to the Signal Source output port. And the cable should be connect between the Amplifier and the Substitution Antenna. The cable loss (Pcl), the Substitution Antenna Gain (Ga) and the Amplifier Gain (PAg) should be recorded after test.  
The measurement results are obtained as described below:  
Power(EIRP)=PMea- PAg - Pcl - Ga  
We used SMF100A microwave signal generator which signal level can up to 33dBm,so we not used power Amplifier for substitution test; The measurement results are amend as described below:  
Power(EIRP)=PMea- Pcl - Ga
7. This value is EIRP since the measurement is calibrated using an antenna of known gain (2.15 dBi) and known input power.
8. ERP can be calculated from EIRP by subtracting the gain of the dipole, ERP = EIRP-2.15dBi.

## UnionTrust Quality and Technology Co., Ltd.

**TEST MODE:**

Please reference to the section 3.4

**TEST RESULTS**

**Passed**       **Not Applicable**

Note:

1. In general, the worse case attenuation requirement shown above was applied.
2. The measurement frequency range from 30 MHz to 5 GHz.
3. We tested TX1 to TX6 recorded worst case TX1, TX3 and TX5.

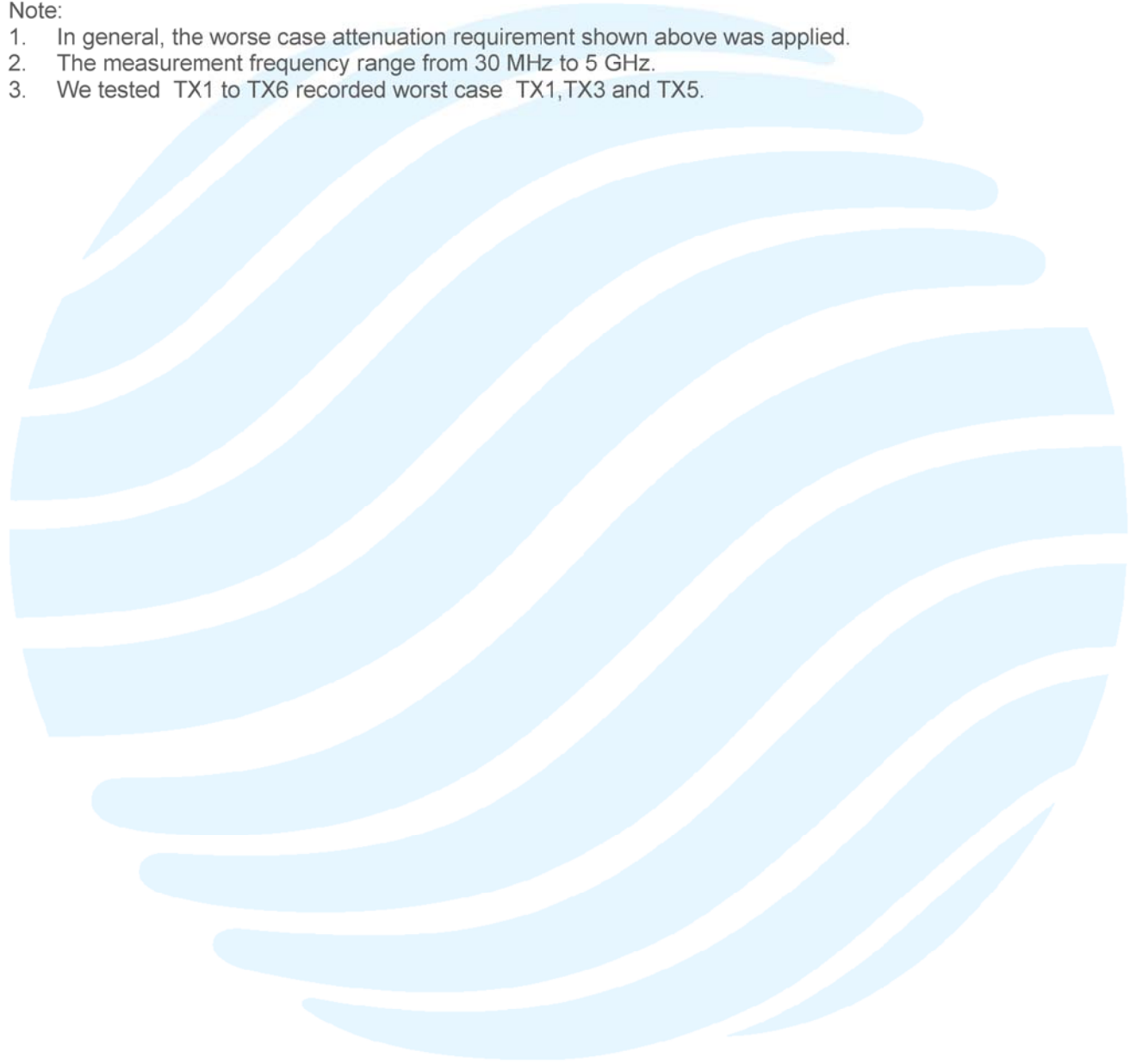

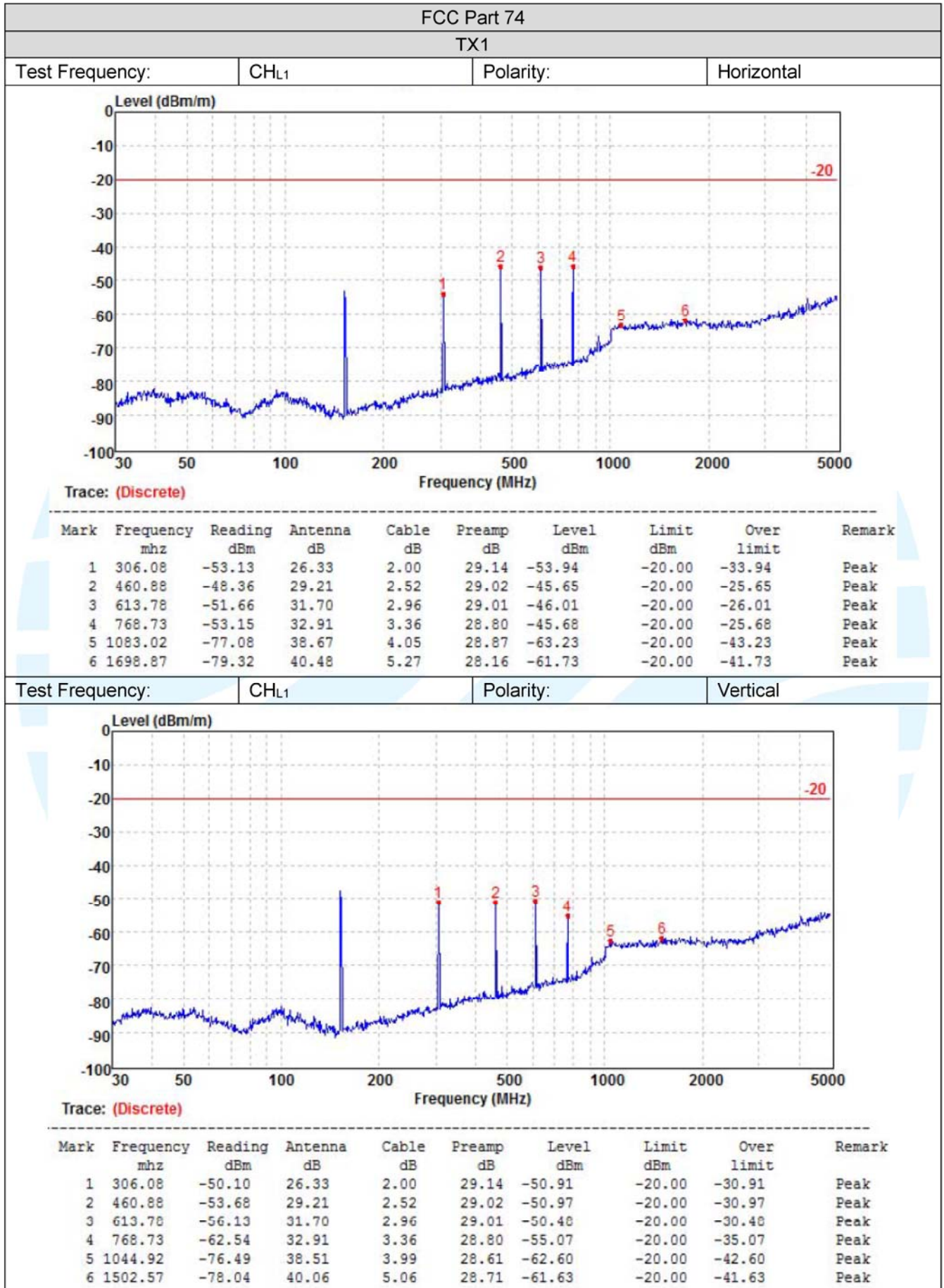

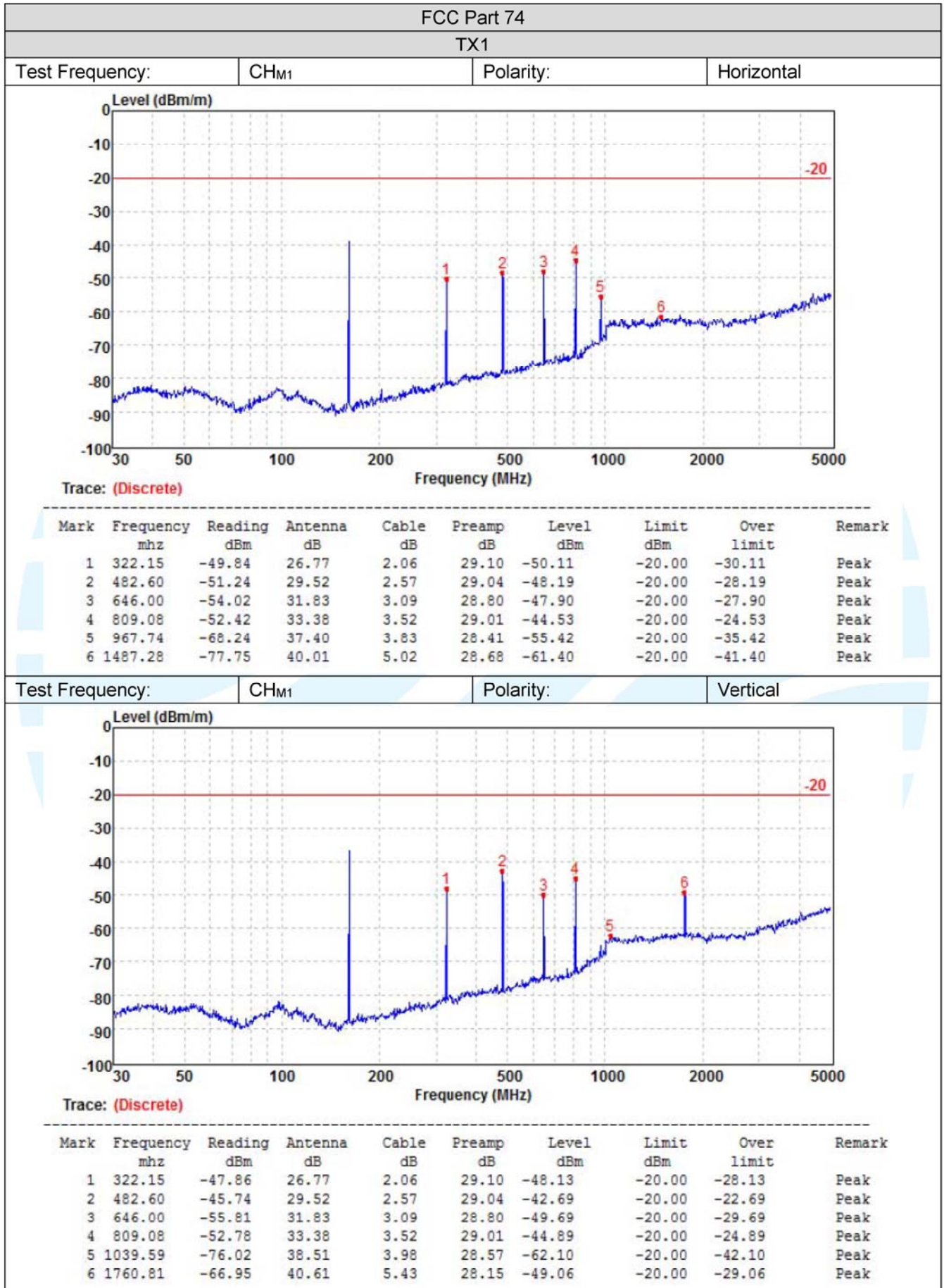

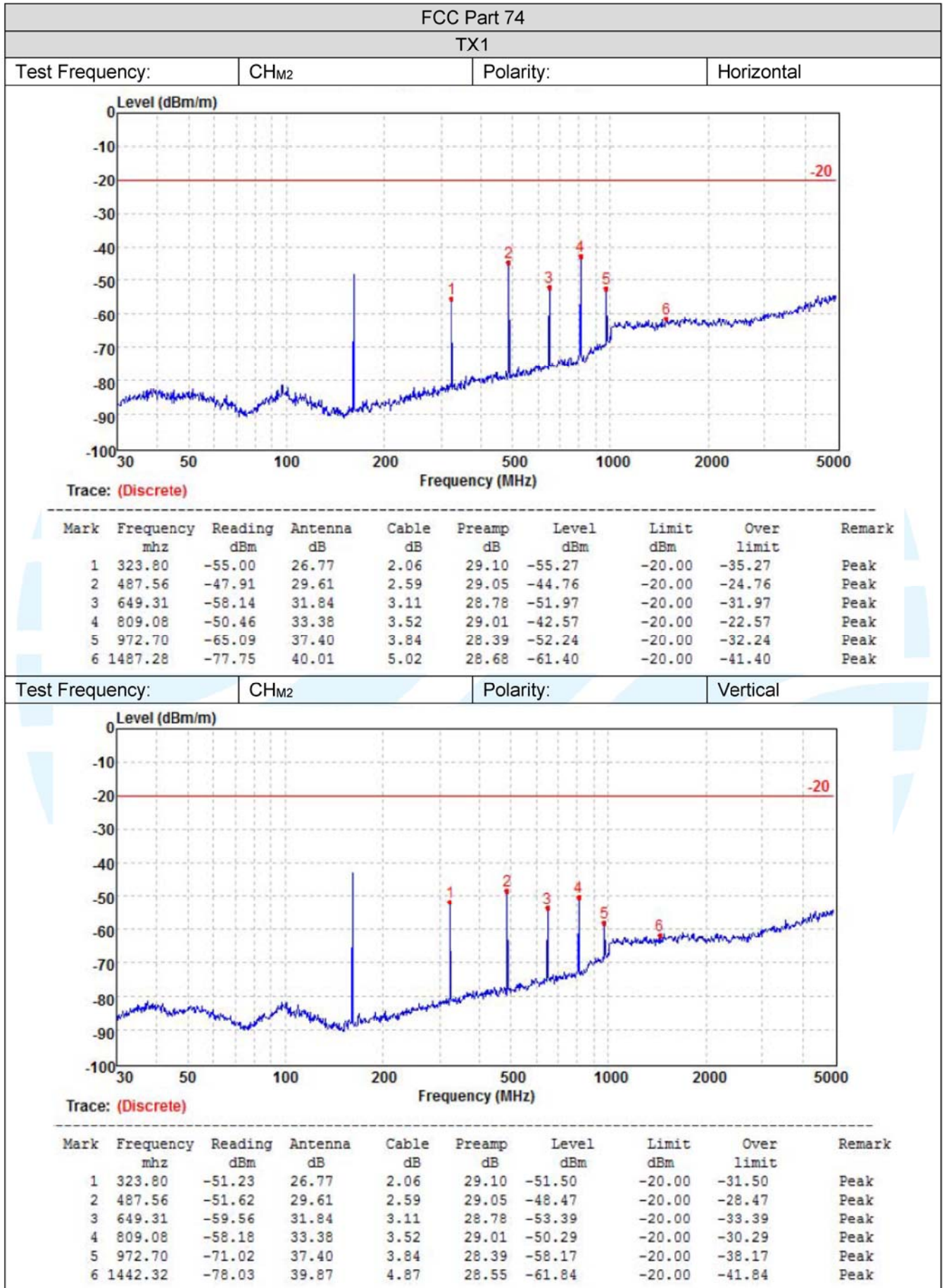

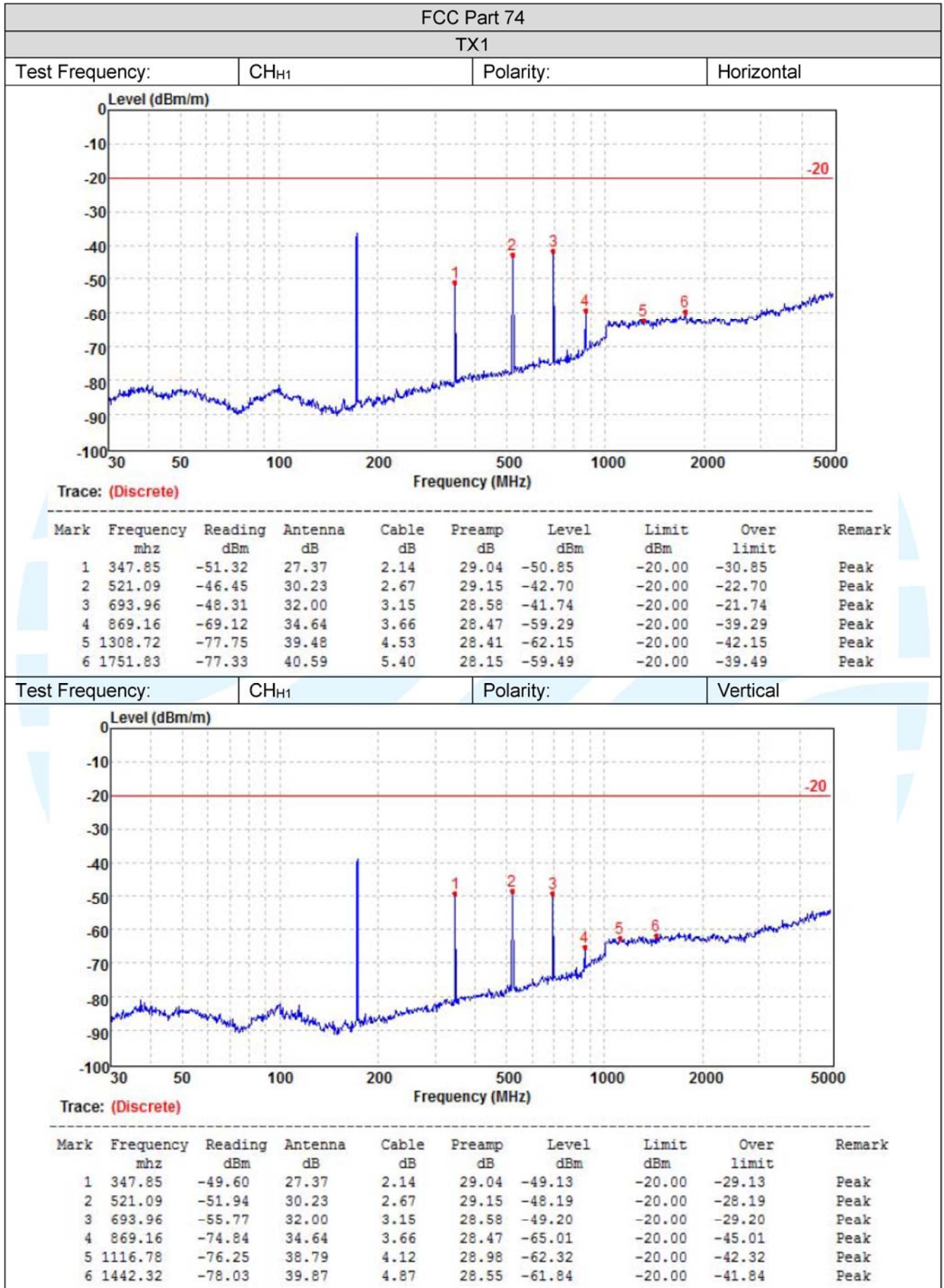

FCC Part 74

TX3

Test Frequency: CHL1      Polarity: Horizontal

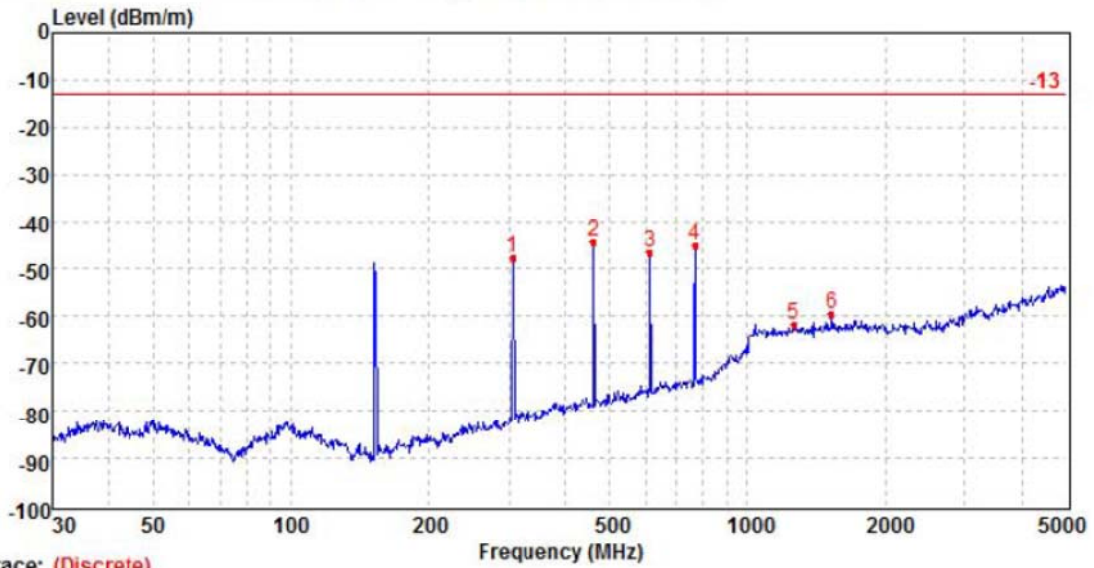

Trace: (Discrete)

Mark	Frequency mhz	Reading dBm	Antenna dB	Cable dB	Preamp dB	Level dBm	Limit dBm	Over limit	Remark
1	306.08	-46.87	26.33	2.00	29.14	-47.68	-13.00	-34.68	Peak
2	460.88	-46.95	29.21	2.52	29.02	-44.24	-13.00	-31.24	Peak
3	613.78	-52.24	31.70	2.96	29.01	-46.59	-13.00	-33.59	Peak
4	768.73	-52.52	32.91	3.36	28.80	-45.05	-13.00	-32.05	Peak
5	1262.68	-76.82	39.32	4.44	28.61	-61.67	-13.00	-48.67	Peak
6	1525.81	-76.03	40.11	5.08	28.72	-59.56	-13.00	-46.56	Peak

Test Frequency: CHL1      Polarity: Vertical

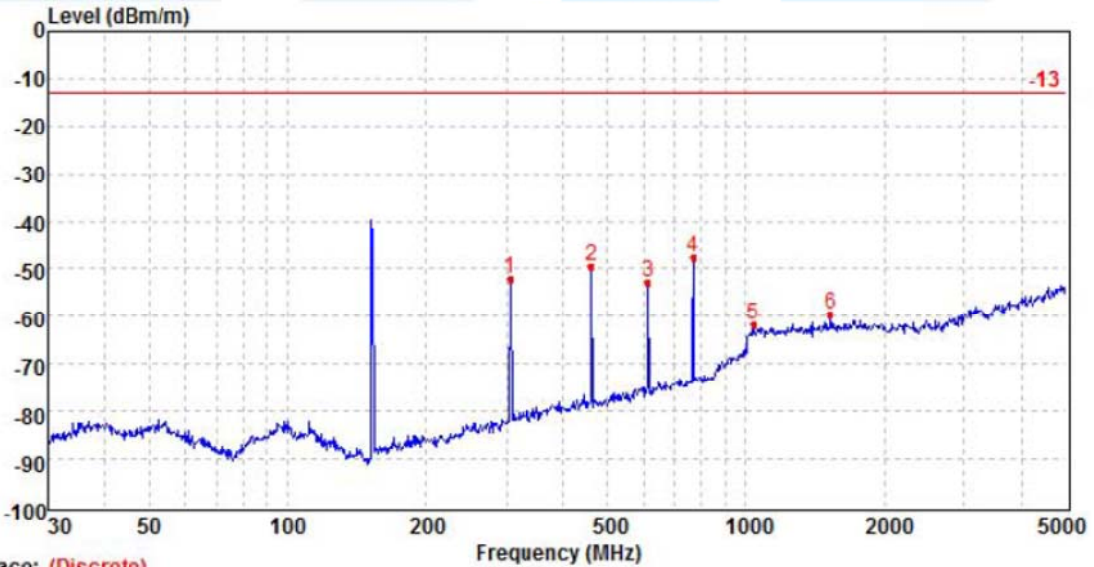

Trace: (Discrete)

Mark	Frequency mhz	Reading dBm	Antenna dB	Cable dB	Preamp dB	Level dBm	Limit dBm	Over limit	Remark
1	306.08	-51.17	26.33	2.00	29.14	-51.98	-13.00	-38.98	Peak
2	460.88	-52.15	29.21	2.52	29.02	-49.44	-13.00	-36.44	Peak
3	613.78	-58.46	31.70	2.96	29.01	-52.81	-13.00	-39.81	Peak
4	768.73	-54.90	32.91	3.36	28.80	-47.43	-13.00	-34.43	Peak
5	1039.59	-75.64	38.51	3.98	28.57	-61.72	-13.00	-48.72	Peak
6	1525.81	-76.03	40.11	5.08	28.72	-59.56	-13.00	-46.56	Peak



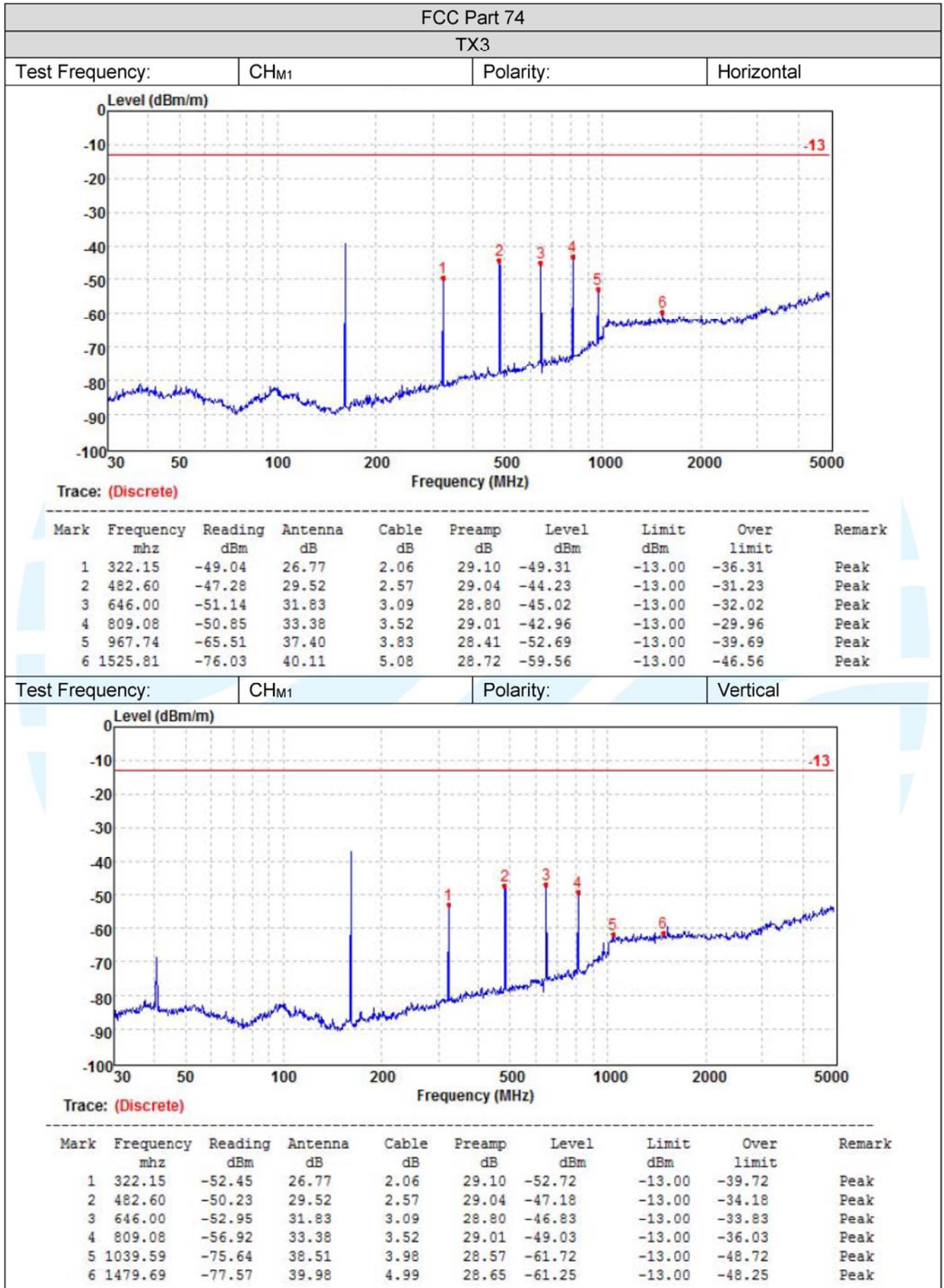

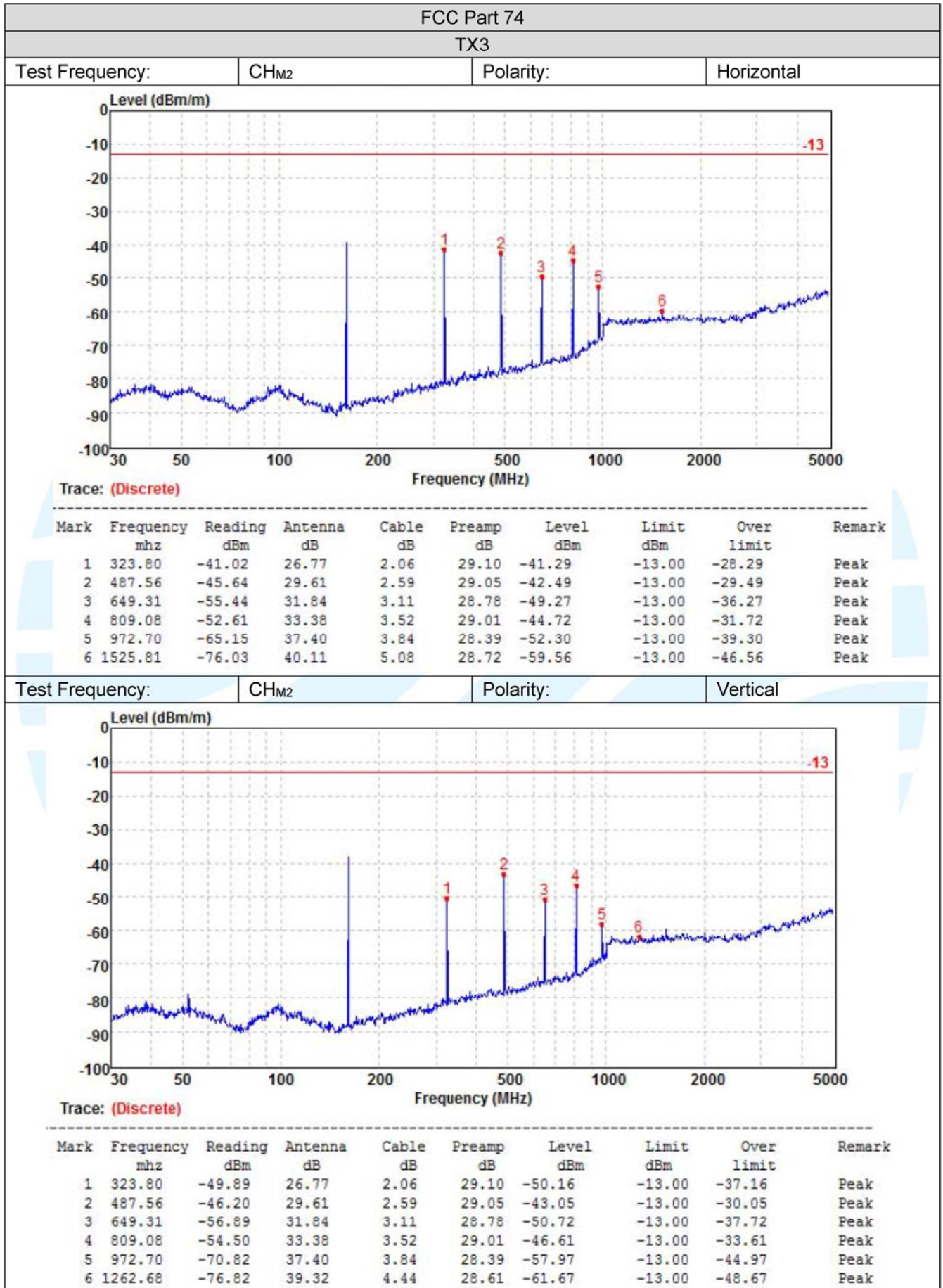

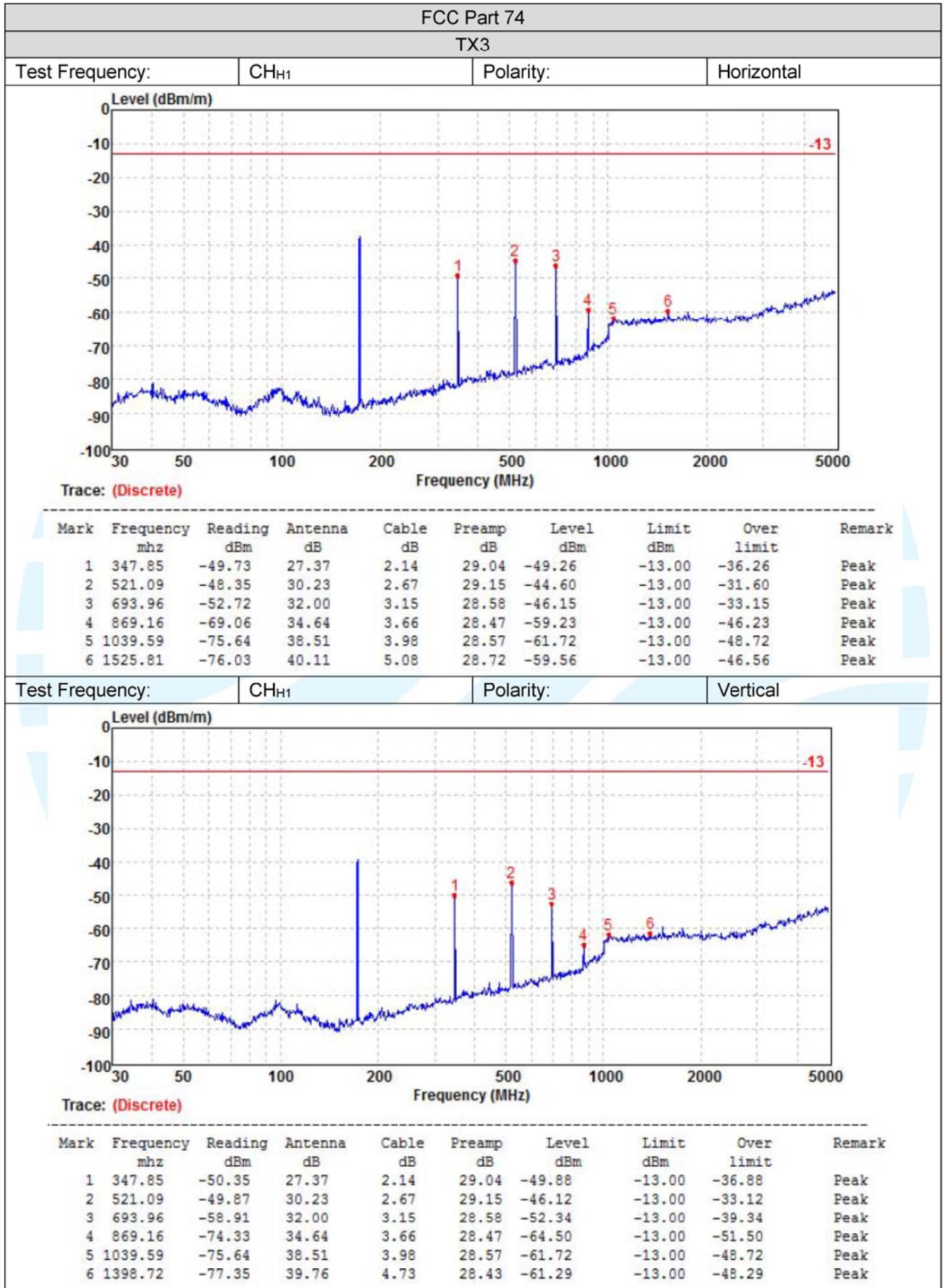

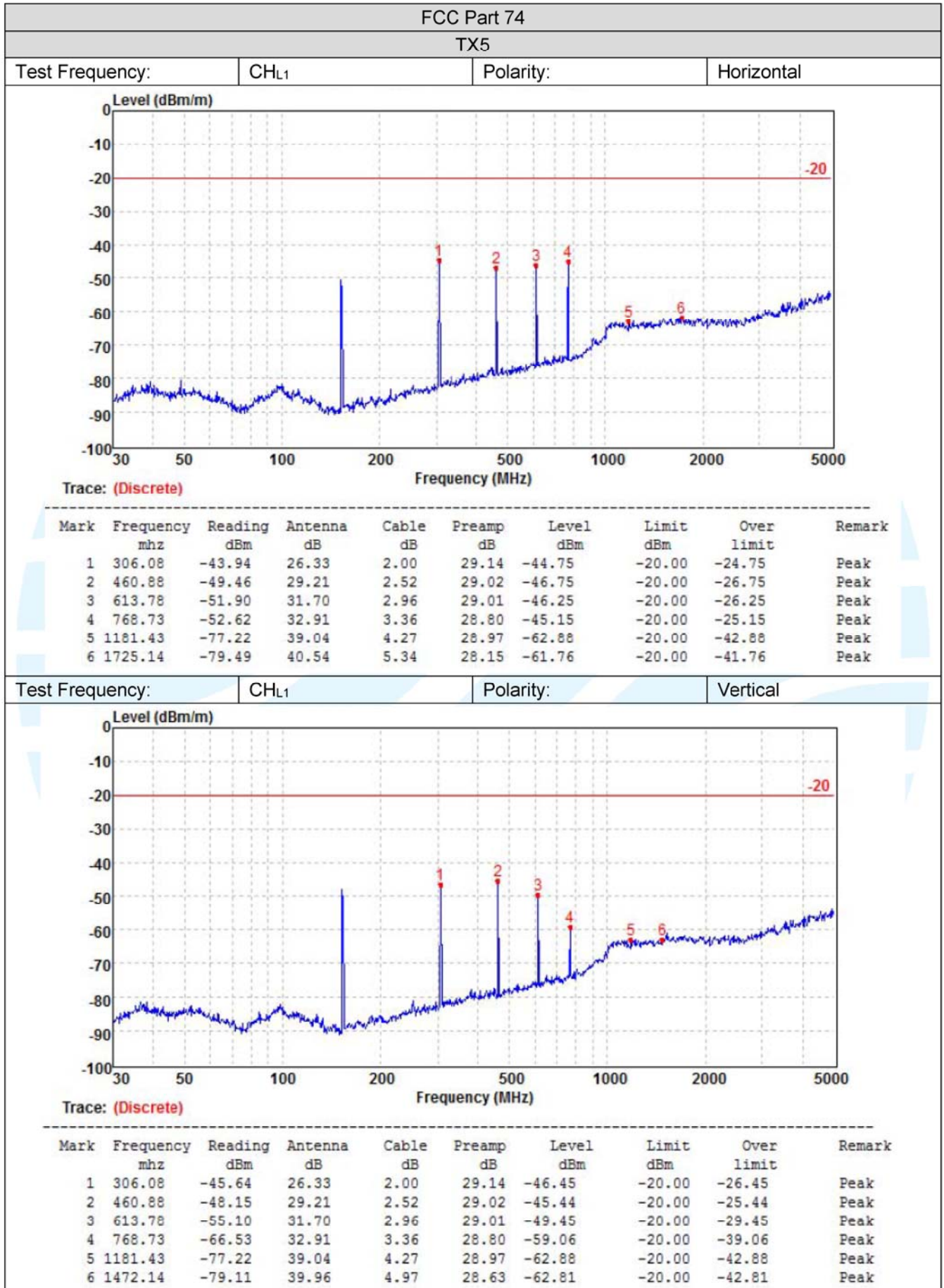

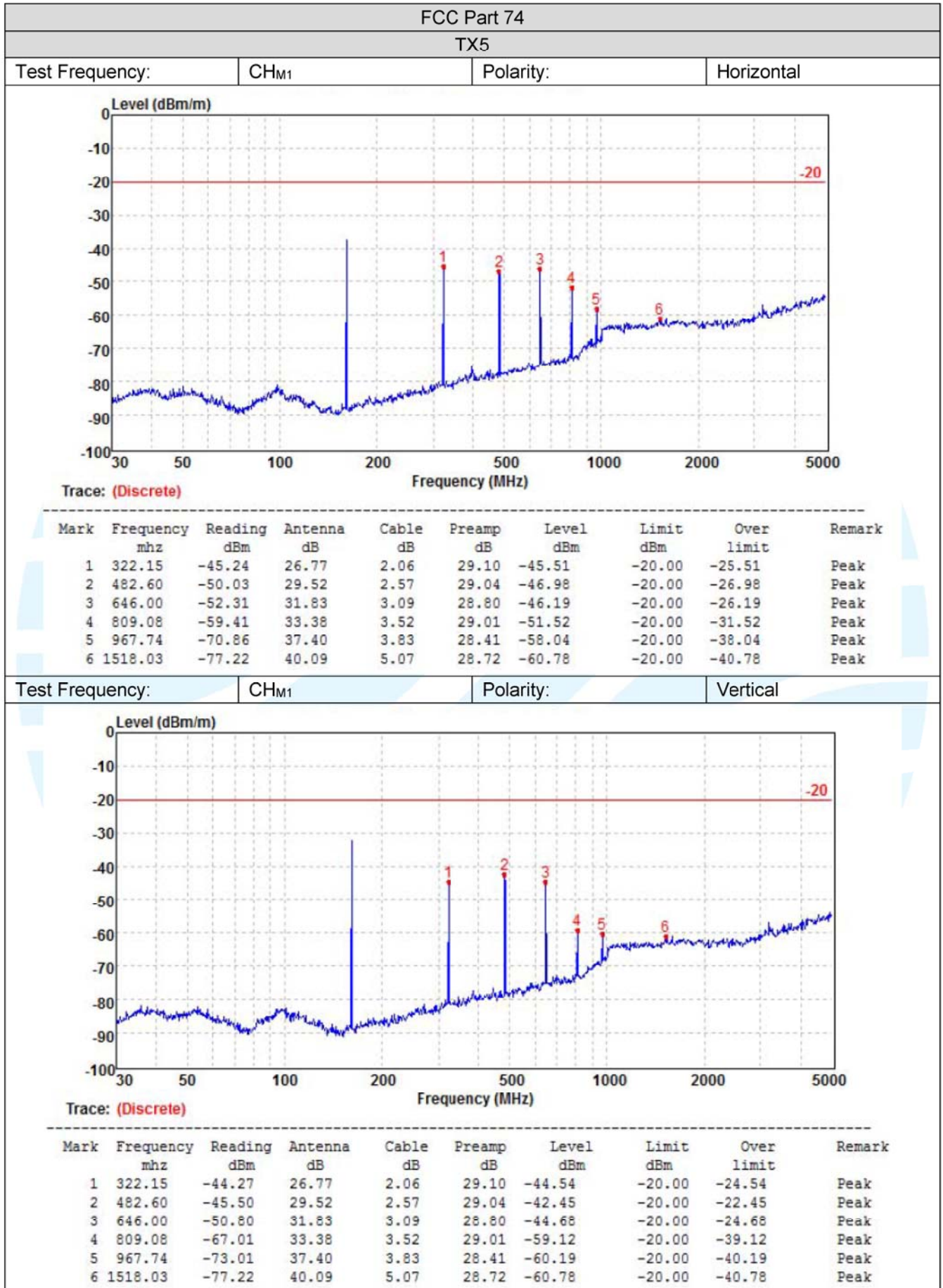

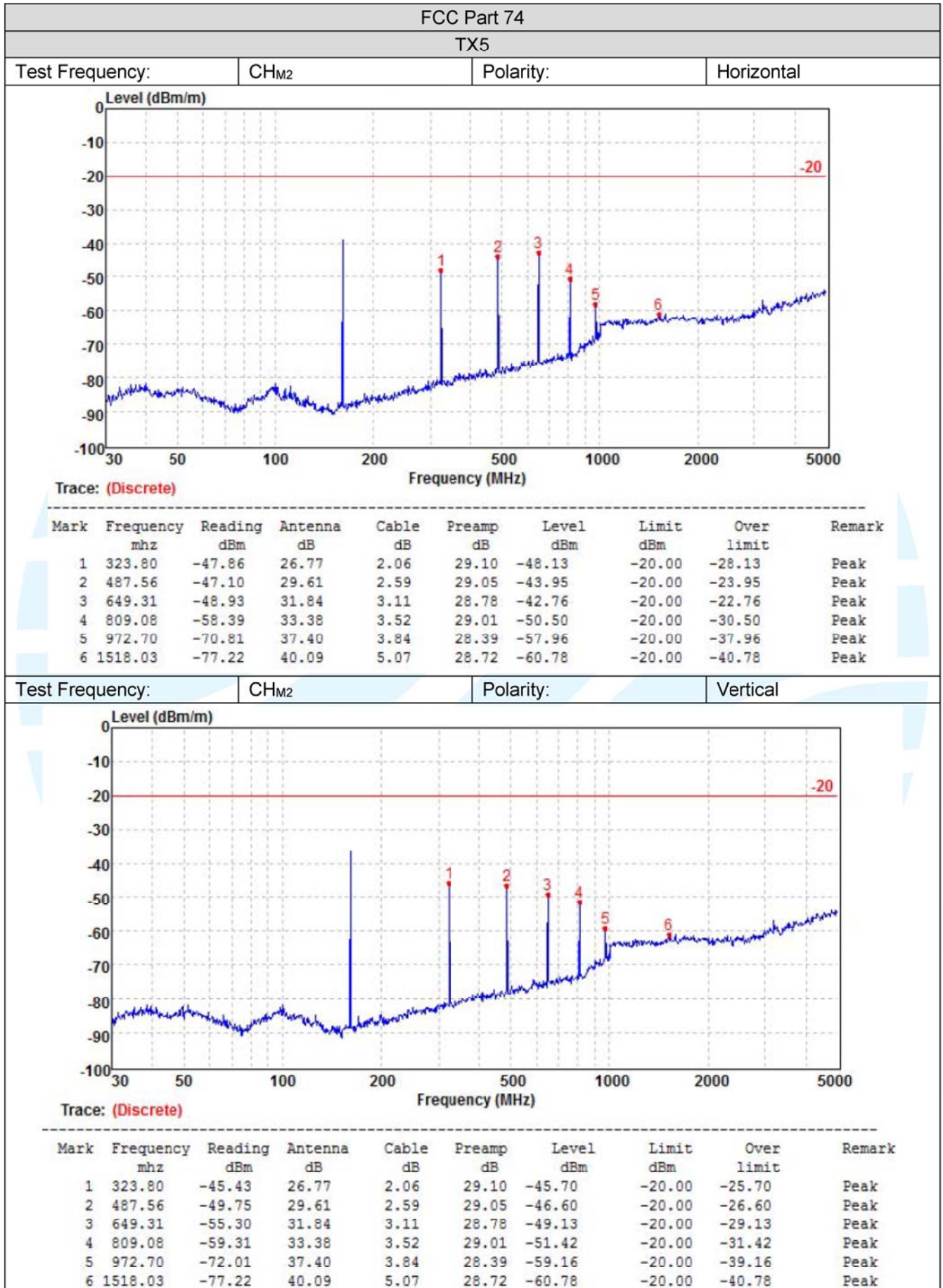

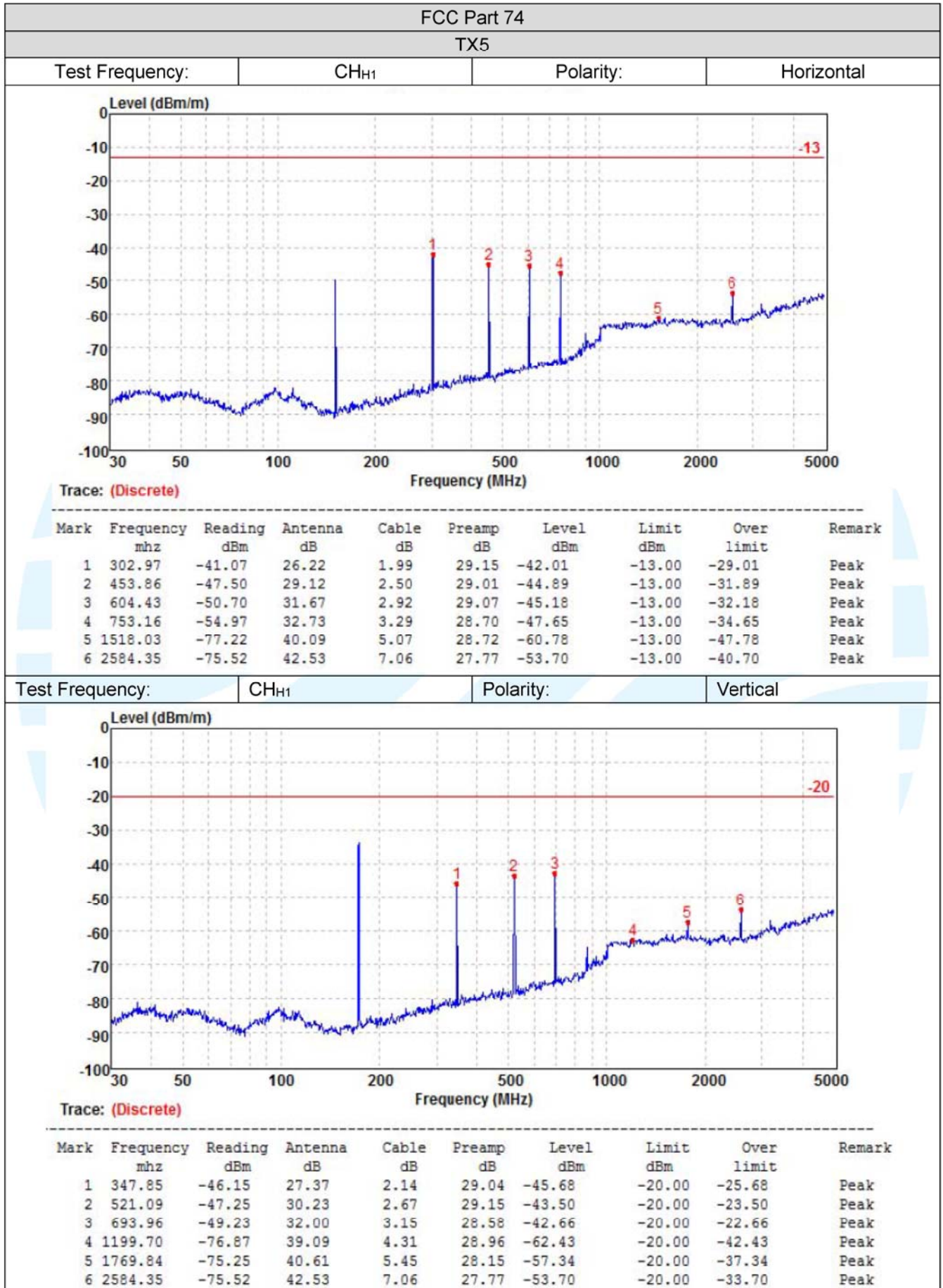

## 6. Test Setup Photos of the EUT

Transmitter Radiated Spurious Emission:

30MHz-1GHz

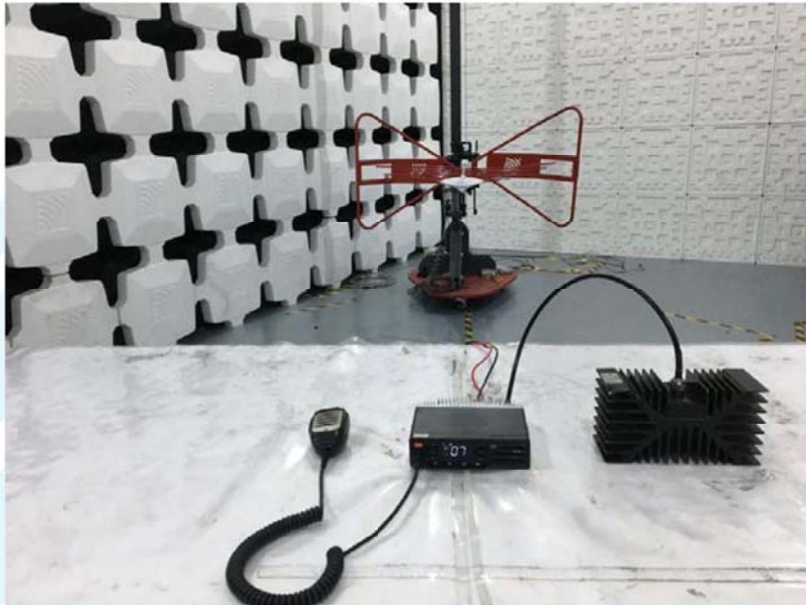

Above 1GHz

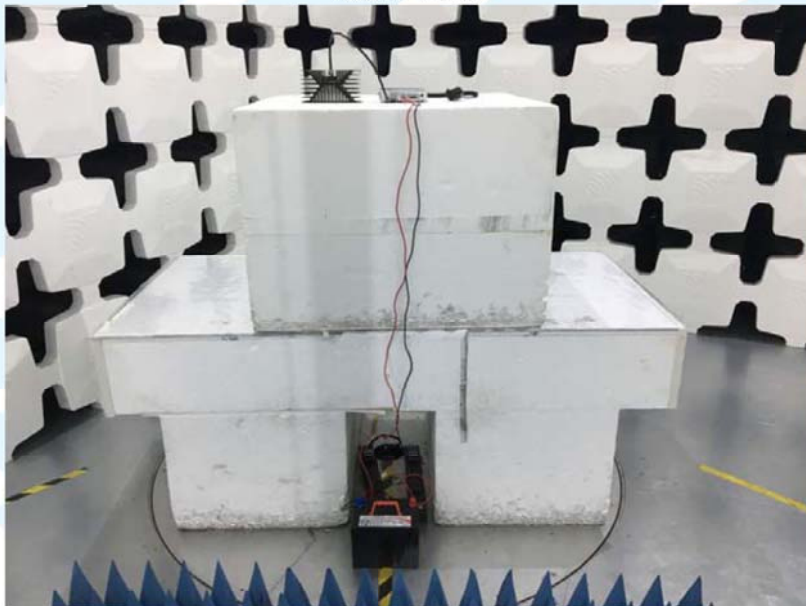



Frequency stability:



## 7. External and Internal Photos of the EUT

Reference to Test Report No.: TRE1711016601.

-----End of Report-----