

# 1. Product Overview

## 1.1 Front Panel

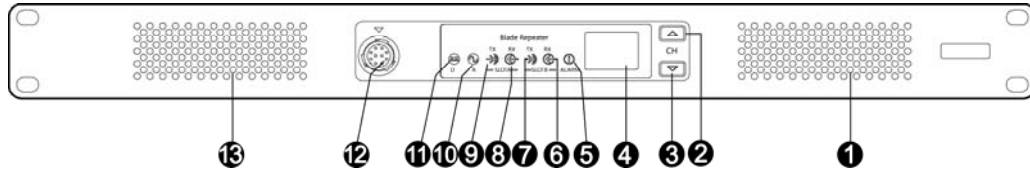

| No. | Part Name               | No. | Part Name                   |
|-----|-------------------------|-----|-----------------------------|
| 1   | Air Inlet for PA        | 8   | Timeslot A RX Indicator     |
| 2   | Channel Up Key          | 9   | Timeslot A TX Indicator     |
| 3   | Channel Down Key        | 10  | Analog Mode Indicator       |
| 4   | Seven-segment Display   | 11  | Digital Mode Indicator      |
| 5   | Alarm Indicator         | 12  | Audio/Programming Connector |
| 6   | Timeslot B RX Indicator | 13  | Air Inlet for Power Supply  |
| 7   | Timeslot B TX Indicator | /   | /                           |

## 1.2 Rear Panel

### 1.2.1 General Version

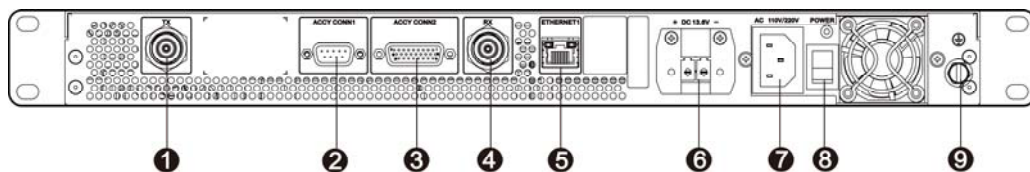

| No. | Part Name                | No. | Part Name       |
|-----|--------------------------|-----|-----------------|
| 1   | TX Antenna Connector     | 6   | DC Power Inlet  |
| 2   | Monitor/Tuning Interface | 7   | AC Power Inlet  |
| 3   | Accessory Connector      | 8   | AC Power Switch |
| 4   | RX Antenna Connector     | 9   | Ground Screw    |
| 5   | LAN Interface            | /   | /               |

## 1.2.2 Enhanced Version

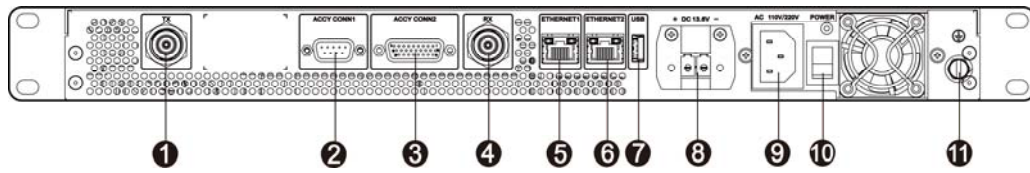

| No. | Part Name                | No. | Part Name       |
|-----|--------------------------|-----|-----------------|
| 1   | TX Antenna Connector     | 7   | USB Connector   |
| 2   | Monitor/Tuning Interface | 8   | DC Power Inlet  |
| 3   | Accessory connector      | 9   | AC Power Inlet  |
| 4   | RX Antenna Connector     | 10  | AC Power Switch |
| 5   | LAN Interface            | 11  | Ground Screw    |
| 6   | WAN Interface            | /   | /               |

## 1.3 Internal Parts

### 1.3.1 General Version

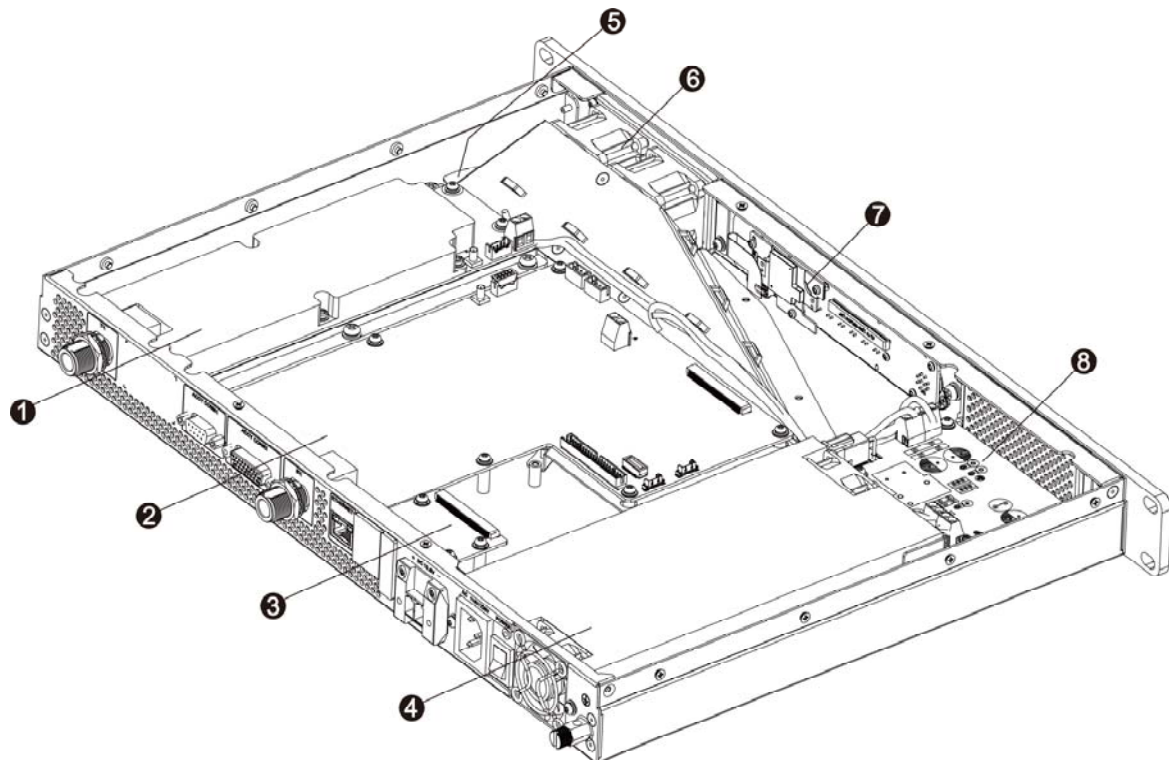

| No. | Part Name           | No. | Part Name             |
|-----|---------------------|-----|-----------------------|
| 1   | PA Module           | 5   | Wind Scooper          |
| 2   | Baseband Module     | 6   | Fan                   |
| 3   | Network Board       | 7   | Control Panel         |
| 4   | Power Supply Module | 8   | Floating Charge Board |

### 1.3.2 Enhanced Version

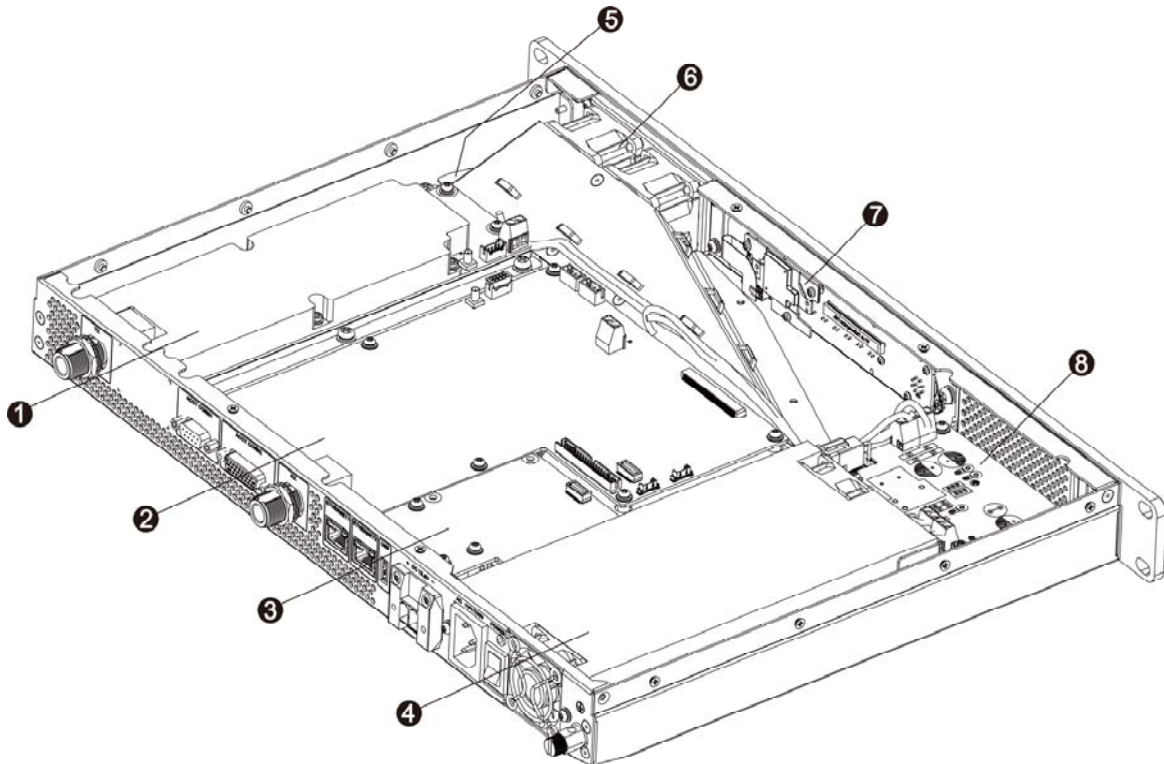

| No. | Part Name           | No. | Part Name             |
|-----|---------------------|-----|-----------------------|
| 1   | PA Module           | 5   | Wind Scooper          |
| 2   | Baseband Module     | 6   | Fan                   |
| 3   | Coprocessor         | 7   | Control Panel         |
| 4   | Power Supply Module | 8   | Floating Charge Board |

## 2. Installation

To ensure optimum performance and reliability of the repeater, read the following instructions carefully.

### 2.1 Installation Requirements

#### Installation Environment

The repeater must be installed in a dry and well-ventilated place. The ambient temperature ranges from  $-30^{\circ}\text{C}$  to  $+60^{\circ}\text{C}$ , and the relative humidity is 95%.

#### Installation Location

The repeater can be installed in a rack, bracket, and cabinet, or on a desk.

---

#### NOTE

For more information, refer to the *Safety Information Booklet*.

---

### 2.2 Pre-installation Tasks

#### Preparing the tools

- Phillips screwdriver
- T-10 torx screwdriver
- Spanner
- Anti-static gloves
- Multimeter

#### Checking the power supply

Before you install the repeater, make sure that the power supply meets the following requirements:

- DC power voltage:  $13.6 \pm 15\%$  V
- AC power voltage: 100–240 V

### 2.3 Installation Procedure

To install the repeater, do as follows:

1. Wear the anti-static gloves.
  2. Place the repeater to a proper location.
  3. Connect accessories including the antenna, feed lines, and power cords to the repeater.
- 

 **NOTE**

You must purchase the antenna and feed lines separately.

---

4. Ground the repeater through the ground screw located on the rear panel.

## 2.4 Post-installation Check

To check whether the repeater works properly, do as follows:

1. Turn the repeater on.
  2. Observe the LED indicators and the display in the front panel.
- 

 **NOTE**

For details, refer to [3.3 Checking Status Indications](#).

---

## 3. Basic Operations

### 3.1 Turning the Repeater On or Off

- If the repeater is connected to a DC power supply, press the power switch on the DC power supply to turn the repeater on or off.
- If the repeater is connected to an AC power supply, press the **AC Power Switch** located in the rear panel to turn the repeater on or off.

### 3.2 Switching the Channel

You can use the **Channel Up** or **Channel Down** key in the front panel to switch the channel. After you switch the channel, the current channel number appears on the display of the repeater.

- To go back to the previous channel, press the **Channel Up** key.
- To go to the next channel, press the **Channel Down** key.

### 3.3 Checking Status Indications

#### 3.3.1 Repeater Status

| Indicator     | Description | Repeater Status  |
|---------------|-------------|--|
| Digital Mode  | Blue        | The repeater is operating in digital mode.   |
| Analog Mode   | Yellow      | The repeater is operating in analog mode.  |
| Alarm         | Red         | The repeater is not working properly.  |
| Timeslot A TX | Red         | <ul style="list-style-type: none"><li>● Analog mode: The repeater is transmitting.</li><li>● Digital mode: The repeater is transmitting in timeslot A.</li></ul> |
| Timeslot A RX | Green       | <ul style="list-style-type: none"><li>● Analog mode: The repeater is receiving.</li><li>● Digital mode: The repeater is receiving in timeslot A.</li></ul>       |
| Timeslot B TX | Red         | Digital mode: The repeater is transmitting in  |

| Indicator     | Description | Repeater Status  |
|---------------|-------------|--|
|               |             | timeslot B.  |
| Timeslot B RX | Green       | Digital mode: The repeater is receiving in timeslot B. |

### 3.3.2 Network Interface

| Indicator                   |       | Description | Repeater Status                             |
|-----------------------------|-------|-------------|---|
| LAN interface/WAN interface | LED 1 | Flashing    | The network card is transmitting data.      |
|                             | LED 2 | Glowing     | The data transmission rate is 1000 M/100 M. |
|                             |       | Off         | The Data transmission rate is 10 M.         |

## **FCC Statement**

This equipment has been tested and found to comply with the limits for a Class B digital device, pursuant to part 15 of FCC Rules. These limits are designed to provide reasonable protection against harmful interference in a residential installation. This equipment generates and can radiate radio frequency energy. If not installed and used in accordance with the instructions, it may cause harmful interference to radio communications. However, there is no guarantee that interference will not occur in a particular installation. Verification of harmful interference by this equipment to radio or television reception can be determined by turning it off and then on. The user is encouraged to try to correct the interference by one or more of the following measures:

- Reorient or relocate the receiving antenna. Increase the separation between the equipment and receiver.
- Connect the equipment into an outlet on a different circuit to that of the receiver's outlet.
- Consult the dealer or an experienced radio/TV technician for help.

Operation is subject to the following two conditions:

- This device may not cause harmful interference.
- This device must accept any interference received, including interference that may cause undesired operation.

Note: Any changes or modifications to this unit not expressly approved by the party responsible for compliance could void the user's authority to operate the equipment.

## **Operational Instructions and Training Guidelines**

To ensure optimal performance and compliance with the occupational/controlled environment RF energy exposure limits in the above standards and guidelines, users should transmit not more than 50% of the time and always adhere to the following procedures:

- Antenna gain must not exceed 10dBi.
- The antenna must be installed complying with the requirements of manufacturer or supplier, and it must be at least 200 cm away from human body.



## **FCC Radiation Exposure Statement:**

This equipment complies with FCC radiation exposure limits set forth for an occupational/controlled environment.

This transmitter must not be co-located or operating in conjunction with any other antenna or transmitter. This equipment should be installed and operated with minimum distance 200cm between the radiator & your body.

## **ISED Statement**

This device complies with Innovation, Science and Economic Development Canada Compliance license-exempt RSS standard(s). Operation is subject to the following two conditions:

- This device may not cause harmful interference.
- This device must accept any interference received, including interference that may cause undesired operation.

Le présent appareil est conforme aux CNR d'Industrie Canada applicables aux appareils radio exempts de licence. L'exploitation est autorisée aux deux conditions suivantes: (1) l'appareil ne doit pas produire de brouillage, et (2) l'utilisateur de l'appareil doit accepter tout brouillage radioélectrique subi, même si le brouillage est susceptible d'en compromettre le fonctionnement

## **ISED Radiation Exposure Statement:**

This equipment complies with ISED RF radiation exposure limits set forth for an occupational/controlled environment. This transmitter must not be co-located or operating in conjunction with any other antenna or transmitter. This equipment should be installed and operated with minimum distance 200cm between the radiator & your body.

## **IC exposition aux radiations:**

Cet équipement est conforme avec ISED les limites d'exposition aux rayonnements définies pour un environnement professionnel/contrôlé. Cet émetteur ne doit pas être co-localisés ou fonctionner en conjonction avec une autre antenne ou émetteur. Cet équipement doit être installé et utilisé avec une distance minimale de 200cm entre le radiateur & votre corps.

## **RF Exposure Compliance and Control Guidelines and Operating Instructions**

To control your exposure and ensure compliance with the occupational/controlled environmental exposure limits, always adhere to the following procedures.

Guidelines:

- Do not remove the RF Exposure Label from the device.

- User awareness instructions should accompany device when transferred to other users.

- Do not use this device if the operational requirements described herein are not met.

Operating Instructions:

- Transmit no more than the rated duty factor of 50% of the time.

- Keep the radio unit at least 200 cm away from the human.