

**Test Plot 1#: PTT\_FM 12.5kHz\_Face Up\_350.0125 MHz****DUT: HP782 Uv; Type: Digital Portable Radio; Serial: 19052100220**

Communication System: FM; Frequency: 350.012 MHz; Duty Cycle: 1:1

Medium parameters used:  $f = 350.012$  MHz;  $\sigma = 0.836$  S/m;  $\epsilon_r = 45.856$ ;  $\rho = 1000$  kg/m<sup>3</sup>

Phantom section: Flat Section

DASY5 Configuration:

- Probe: ES3DV2 - SN3019; ConvF(7.18, 7.18, 7.18); Calibrated: 2018/8/20;
- Sensor-Surface: 4mm (Mechanical Surface Detection)
- Electronics: DAE3 Sn471; Calibrated: 2018/12/3
- Phantom: ELI v8.0; Type: QDOVA004AA; Serial: 2051
- Measurement SW: DASY52, Version 52.8 (8);

**Area Scan (61x121x1):** Interpolated grid: dx=1.500 mm, dy=1.500 mm

Maximum value of SAR (interpolated) = 6.23 W/kg

**Zoom Scan (5x5x7)/Cube 0:** Measurement grid: dx=8mm, dy=8mm, dz=5mm

Reference Value = 85.54 V/m; Power Drift = -0.16 dB

Peak SAR (extrapolated) = 6.58 W/kg

**SAR(1 g) = 5.58 W/kg; SAR(10 g) = 4.33 W/kg**

Maximum value of SAR (measured) = 5.85 W/kg

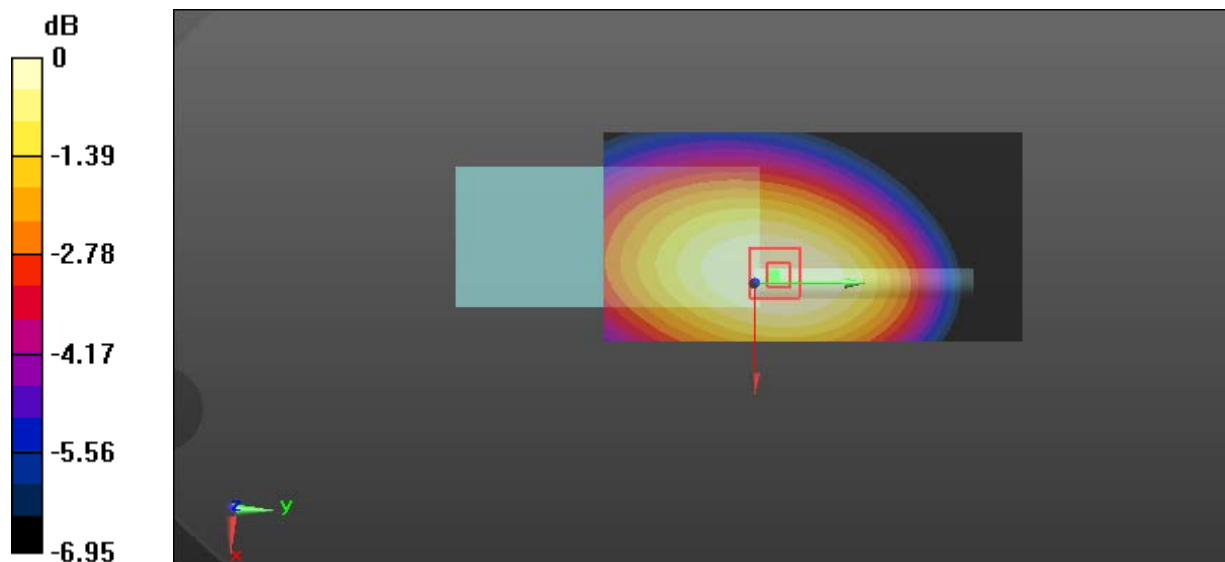

0 dB = 5.85 W/kg = 7.67 dBW/kg

**Test Plot 2#: PTT\_FM 25kHz\_Face Up\_350.0125 MHz****DUT: HP782 Uv; Type: Digital Portable Radio; Serial: 19052100220**

Communication System: FM; Frequency: 350.012 MHz; Duty Cycle: 1:1

Medium parameters used:  $f = 350.012$  MHz;  $\sigma = 0.836$  S/m;  $\epsilon_r = 45.856$ ;  $\rho = 1000$  kg/m<sup>3</sup>

Phantom section: Flat Section

DASY5 Configuration:

- Probe: ES3DV2 - SN3019; ConvF(7.18, 7.18, 7.18); Calibrated: 2018/8/20;
- Sensor-Surface: 4mm (Mechanical Surface Detection)
- Electronics: DAE3 Sn471; Calibrated: 2018/12/3
- Phantom: ELI v8.0; Type: QDOVA004AA; Serial: 2051
- Measurement SW: DASY52, Version 52.8 (8);

**Area Scan (61x121x1):** Interpolated grid: dx=1.500 mm, dy=1.500 mm

Maximum value of SAR (interpolated) = 6.00 W/kg

**Zoom Scan (5x5x7)/Cube 0:** Measurement grid: dx=8mm, dy=8mm, dz=5mm

Reference Value = 83.73 V/m; Power Drift = -0.10 dB

Peak SAR (extrapolated) = 6.62 W/kg

**SAR(1 g) = 5.62 W/kg; SAR(10 g) = 4.36 W/kg**

Maximum value of SAR (measured) = 5.90 W/kg

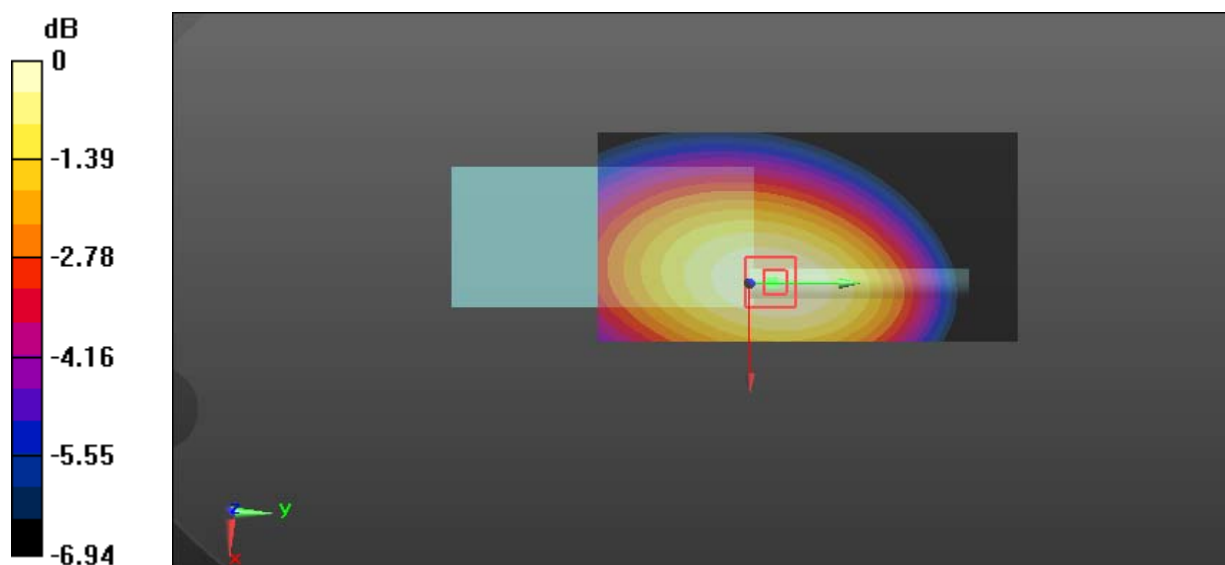

0 dB = 5.90 W/kg = 7.71 dBW/kg

**Test Plot 3#: PTT\_4FSK 12.5kHz\_Face Up\_350.0125 MHz****DUT: HP782 Uv; Type: Digital Portable Radio; Serial: 19052100220**

Communication System: 4FSK; Frequency: 350.012 MHz; Duty Cycle: 1:2

Medium parameters used:  $f = 350.012$  MHz;  $\sigma = 0.836$  S/m;  $\epsilon_r = 45.856$ ;  $\rho = 1000$  kg/m<sup>3</sup>

Phantom section: Flat Section

DASY5 Configuration:

- Probe: ES3DV2 - SN3019; ConvF(7.18, 7.18, 7.18); Calibrated: 2018/8/20;
- Sensor-Surface: 4mm (Mechanical Surface Detection)
- Electronics: DAE3 Sn471; Calibrated: 2018/12/3
- Phantom: ELI v8.0; Type: QDOVA004AA; Serial: 2051
- Measurement SW: DASY52, Version 52.8 (8);

**Area Scan (61x121x1):** Interpolated grid: dx=1.500 mm, dy=1.500 mm

Maximum value of SAR (interpolated) = 2.97 W/kg

**Zoom Scan (5x5x7)/Cube 0:** Measurement grid: dx=8mm, dy=8mm, dz=5mm

Reference Value = 57.13 V/m; Power Drift = -0.11 dB

Peak SAR (extrapolated) = 3.48 W/kg

**SAR(1 g) = 2.76 W/kg; SAR(10 g) = 2.12 W/kg**

Maximum value of SAR (measured) = 2.94 W/kg

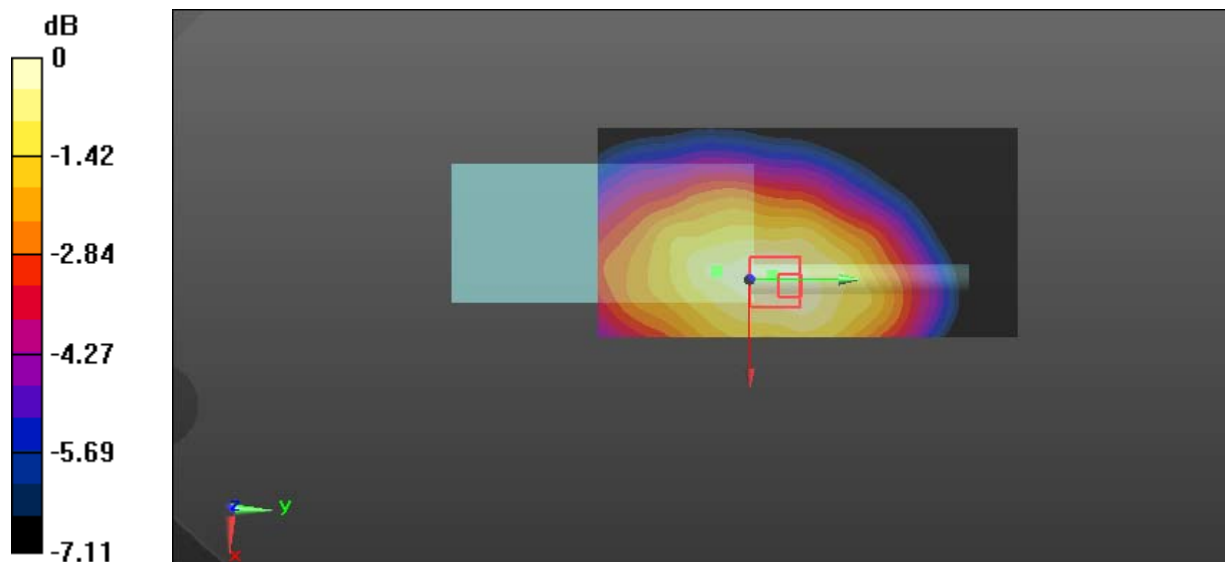

0 dB = 2.94 W/kg = 4.68 dBW/kg

**Test Plot 4#: PTT\_FM 12.5kHz\_Body Back\_350.0125 MHz****DUT: HP782 Uv; Type: Digital Portable Radio; Serial: 19052100220**

Communication System: FM; Frequency: 350.012 MHz; Duty Cycle: 1:1

Medium parameters used:  $f = 350.012$  MHz;  $\sigma = 0.901$  S/m;  $\epsilon_r = 58.327$ ;  $\rho = 1000$  kg/m<sup>3</sup>

Phantom section: Flat Section

DASY5 Configuration:

- Probe: ES3DV2 - SN3019; ConvF(7.1, 7.1, 7.1); Calibrated: 2018/8/20;
- Sensor-Surface: 4mm (Mechanical Surface Detection)
- Electronics: DAE3 Sn471; Calibrated: 2018/12/3
- Phantom: ELI v8.0; Type: QDOVA004AA; Serial: 2051
- Measurement SW: DASY52, Version 52.8 (8);

**Area Scan (61x121x1):** Interpolated grid: dx=1.500 mm, dy=1.500 mm

Maximum value of SAR (interpolated) = 10.1 W/kg

**Zoom Scan (5x5x7)/Cube 0:** Measurement grid: dx=8mm, dy=8mm, dz=5mm

Reference Value = 100.8 V/m; Power Drift = -0.08 dB

Peak SAR (extrapolated) = 11.6 W/kg

**SAR(1 g) = 9.6 W/kg; SAR(10 g) = 7.94 W/kg**

Maximum value of SAR (measured) = 9.95 W/kg

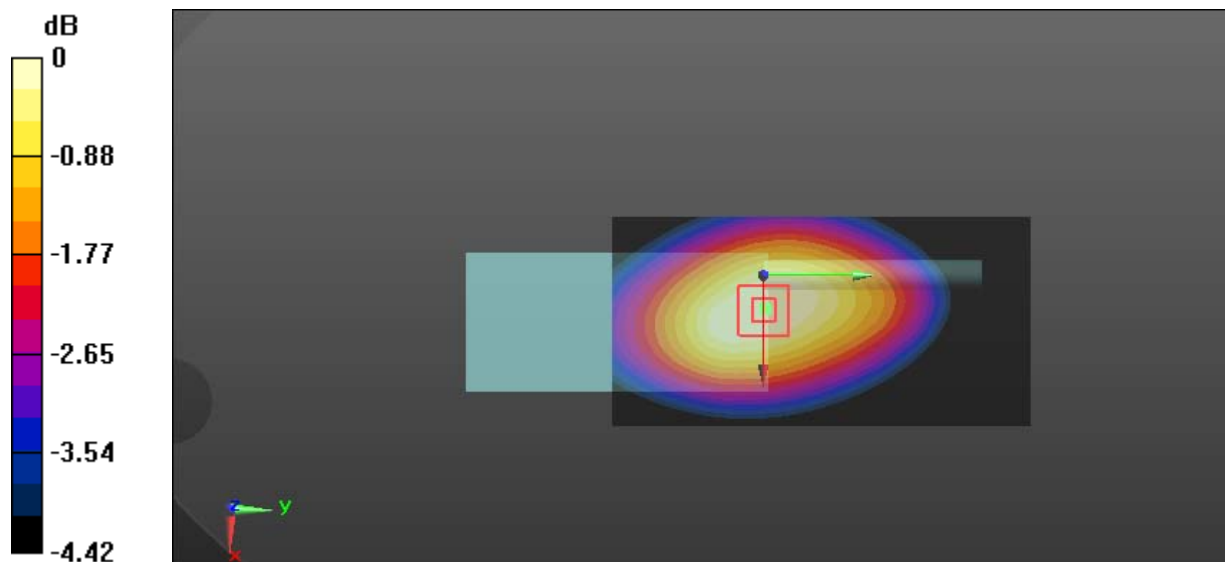

0 dB = 9.95 W/kg = 9.98 dBW/kg

**Test Plot 5#: PTT\_FM 12.5kHz\_Body Back\_362.5125 MHz****DUT: HP782 Uv; Type: Digital Portable Radio; Serial: 19052100220**

Communication System: FM; Frequency: 362.512 MHz; Duty Cycle: 1:1

Medium parameters used:  $f = 362.512$  MHz;  $\sigma = 0.906$  S/m;  $\epsilon_r = 58.169$ ;  $\rho = 1000$  kg/m<sup>3</sup>

Phantom section: Flat Section

DASY5 Configuration:

- Probe: ES3DV2 - SN3019; ConvF(7.1, 7.1, 7.1); Calibrated: 2018/8/20;
- Sensor-Surface: 4mm (Mechanical Surface Detection)
- Electronics: DAE3 Sn471; Calibrated: 2018/12/3
- Phantom: ELI v8.0; Type: QDOVA004AA; Serial: 2051
- Measurement SW: DASY52, Version 52.8 (8);

**Area Scan (61x121x1):** Interpolated grid: dx=1.500 mm, dy=1.500 mm

Maximum value of SAR (interpolated) = 10.5 W/kg

**Zoom Scan (5x5x7)/Cube 0:** Measurement grid: dx=8mm, dy=8mm, dz=5mm

Reference Value = 102.4 V/m; Power Drift = -0.20 dB

Peak SAR (extrapolated) = 11.8 W/kg

**SAR(1 g) = 9.76 W/kg; SAR(10 g) = 7.99 W/kg**

Maximum value of SAR (measured) = 10.1 W/kg

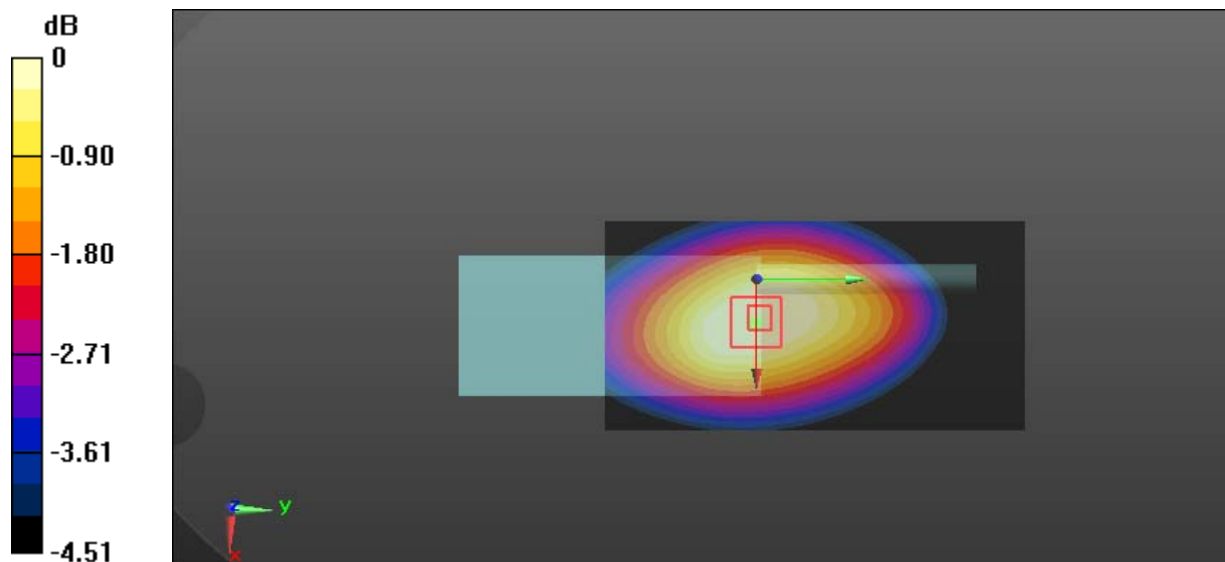

0 dB = 10.1 W/kg = 10.04 dBW/kg

**Test Plot 6#: PTT\_FM 12.5kHz\_Body Back\_375.0125 MHz****DUT: HP782 Uv; Type: Digital Portable Radio; Serial: 19052100220**

Communication System: FM; Frequency: 375.012 MHz; Duty Cycle: 1:1

Medium parameters used:  $f = 375.012$  MHz;  $\sigma = 0.911$  S/m;  $\epsilon_r = 58.023$ ;  $\rho = 1000$  kg/m<sup>3</sup>

Phantom section: Flat Section

DASY5 Configuration:

- Probe: ES3DV2 - SN3019; ConvF(7.1, 7.1, 7.1); Calibrated: 2018/8/20;
- Sensor-Surface: 4mm (Mechanical Surface Detection)
- Electronics: DAE3 Sn471; Calibrated: 2018/12/3
- Phantom: ELI v8.0; Type: QDOVA004AA; Serial: 2051
- Measurement SW: DASY52, Version 52.8 (8);

**Area Scan (61x121x1):** Interpolated grid: dx=1.500 mm, dy=1.500 mm

Maximum value of SAR (interpolated) = 6.70 W/kg

**Zoom Scan (5x5x7)/Cube 0:** Measurement grid: dx=8mm, dy=8mm, dz=5mm

Reference Value = 83.46 V/m; Power Drift = -0.19 dB

Peak SAR (extrapolated) = 7.69 W/kg

**SAR(1 g) = 6.29 W/kg; SAR(10 g) = 5.1 W/kg**

Maximum value of SAR (measured) = 6.54 W/kg

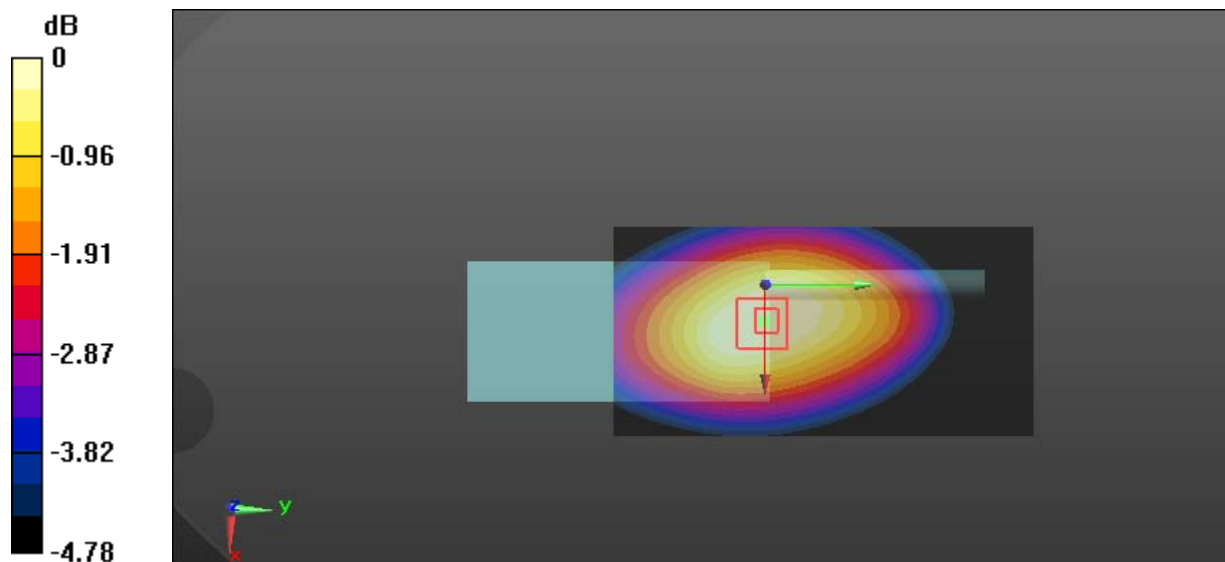

0 dB = 6.54 W/kg = 8.16 dBW/kg

**Test Plot 7#: PTT\_FM 12.5kHz\_Body Back\_387.4875 MHz****DUT: HP782 Uv; Type: Digital Portable Radio; Serial: 19052100220**

Communication System: FM; Frequency: 387.488 MHz; Duty Cycle: 1:1

Medium parameters used:  $f = 387.488$  MHz;  $\sigma = 0.915$  S/m;  $\epsilon_r = 57.854$ ;  $\rho = 1000$  kg/m<sup>3</sup>

Phantom section: Flat Section

DASY5 Configuration:

- Probe: ES3DV2 - SN3019; ConvF(7.1, 7.1, 7.1); Calibrated: 2018/8/20;
- Sensor-Surface: 4mm (Mechanical Surface Detection)
- Electronics: DAE3 Sn471; Calibrated: 2018/12/3
- Phantom: ELI v8.0; Type: QDOVA004AA; Serial: 2051
- Measurement SW: DASY52, Version 52.8 (8);

**Area Scan (61x121x1):** Interpolated grid: dx=1.500 mm, dy=1.500 mm

Maximum value of SAR (interpolated) = 3.55 W/kg

**Zoom Scan (5x5x7)/Cube 0:** Measurement grid: dx=8mm, dy=8mm, dz=5mm

Reference Value = 58.48 V/m; Power Drift = -0.08 dB

Peak SAR (extrapolated) = 4.14 W/kg

**SAR(1 g) = 3.38 W/kg; SAR(10 g) = 2.72 W/kg**

Maximum value of SAR (measured) = 3.50 W/kg

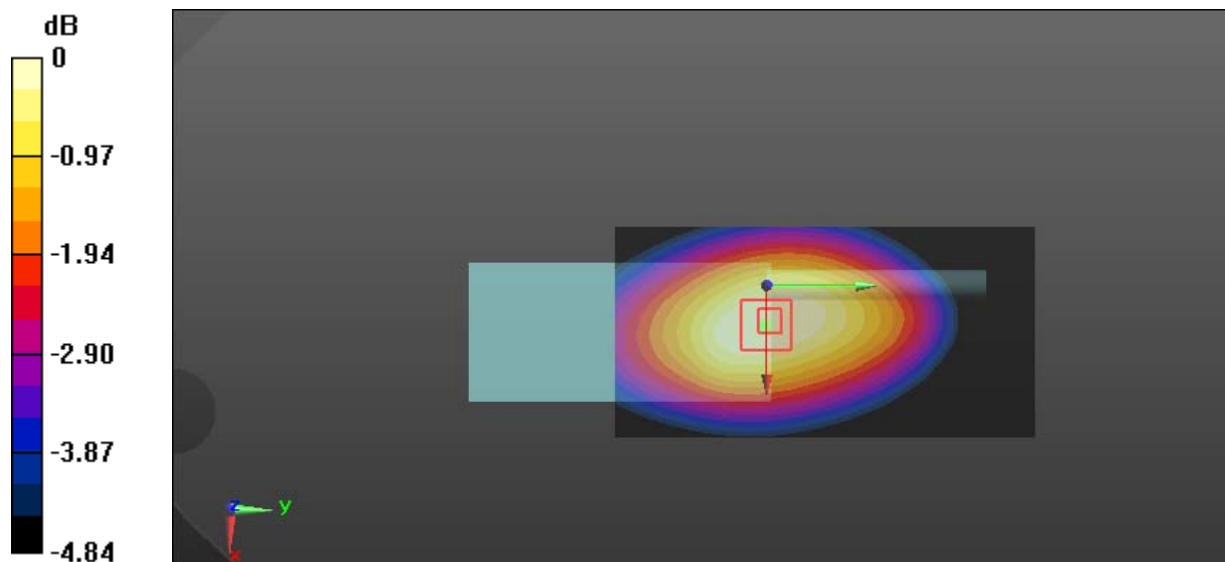

0 dB = 3.50 W/kg = 5.44 dBW/kg

**Test Plot 8#: PTT\_FM 12.5kHz\_Body Back\_399.9875 MHz****DUT: HP782 Uv; Type: Digital Portable Radio; Serial: 19052100220**

Communication System: FM; Frequency: 399.988 MHz; Duty Cycle: 1:1

Medium parameters used:  $f = 399.988$  MHz;  $\sigma = 0.918$  S/m;  $\epsilon_r = 57.697$ ;  $\rho = 1000$  kg/m<sup>3</sup>

Phantom section: Flat Section

DASY5 Configuration:

- Probe: ES3DV2 - SN3019; ConvF(7.1, 7.1, 7.1); Calibrated: 2018/8/20;
- Sensor-Surface: 4mm (Mechanical Surface Detection)
- Electronics: DAE3 Sn471; Calibrated: 2018/12/3
- Phantom: ELI v8.0; Type: QDOVA004AA; Serial: 2051
- Measurement SW: DASY52, Version 52.8 (8);

**Area Scan (61x121x1):** Interpolated grid: dx=1.500 mm, dy=1.500 mm

Maximum value of SAR (interpolated) = 2.58 W/kg

**Zoom Scan (5x5x7)/Cube 0:** Measurement grid: dx=8mm, dy=8mm, dz=5mm

Reference Value = 50.26 V/m; Power Drift = -0.05 dB

Peak SAR (extrapolated) = 3.05 W/kg

**SAR(1 g) = 2.46 W/kg; SAR(10 g) = 1.96 W/kg**

Maximum value of SAR (measured) = 2.56 W/kg

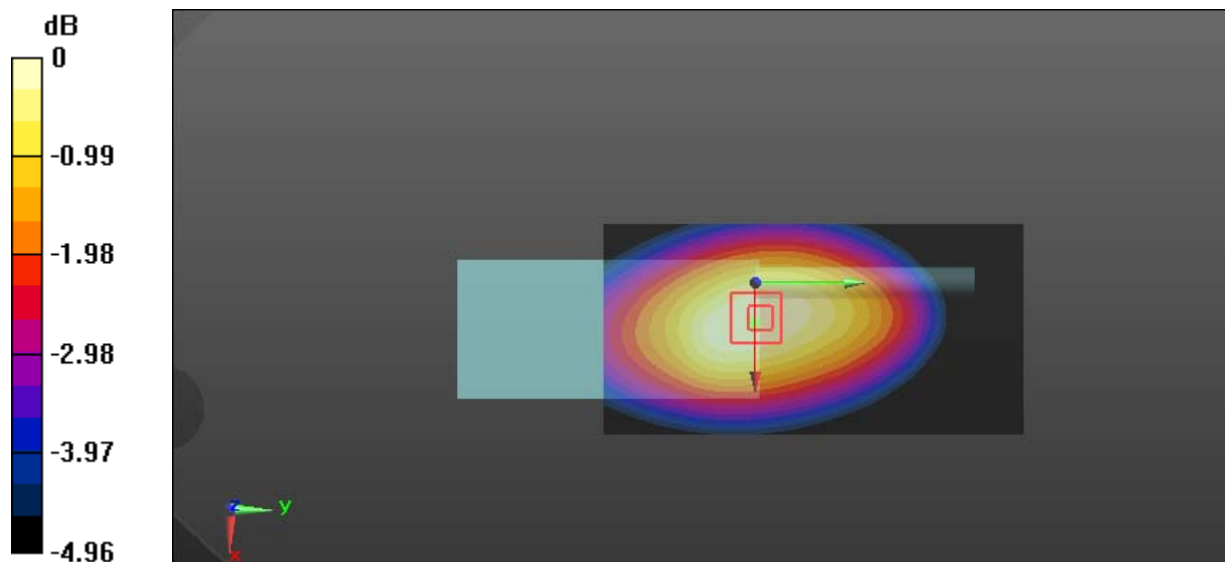

0 dB = 2.56 W/kg = 4.08 dBW/kg



**Test Plot 9#: PTT\_FM 25kHz\_Body Back\_350.0125 MHz****DUT: HP782 Uv; Type: Digital Portable Radio; Serial: 19052100220**

Communication System: FM; Frequency: 350.012 MHz; Duty Cycle: 1:1

Medium parameters used:  $f = 350.012$  MHz;  $\sigma = 0.901$  S/m;  $\epsilon_r = 58.327$ ;  $\rho = 1000$  kg/m<sup>3</sup>

Phantom section: Flat Section

DASY5 Configuration:

- Probe: ES3DV2 - SN3019; ConvF(7.1, 7.1, 7.1); Calibrated: 2018/8/20;
- Sensor-Surface: 4mm (Mechanical Surface Detection)
- Electronics: DAE3 Sn471; Calibrated: 2018/12/3
- Phantom: ELI v8.0; Type: QDOVA004AA; Serial: 2051
- Measurement SW: DASY52, Version 52.8 (8);

**Area Scan (61x121x1):** Interpolated grid: dx=1.500 mm, dy=1.500 mm

Maximum value of SAR (interpolated) = 9.25 W/kg

**Zoom Scan (5x5x7)/Cube 0:** Measurement grid: dx=8mm, dy=8mm, dz=5mm

Reference Value = 99.43 V/m; Power Drift = -0.06 dB

Peak SAR (extrapolated) = 10.8 W/kg

**SAR(1 g) = 8.74 W/kg; SAR(10 g) = 7.08 W/kg**

Maximum value of SAR (measured) = 9.07 W/kg

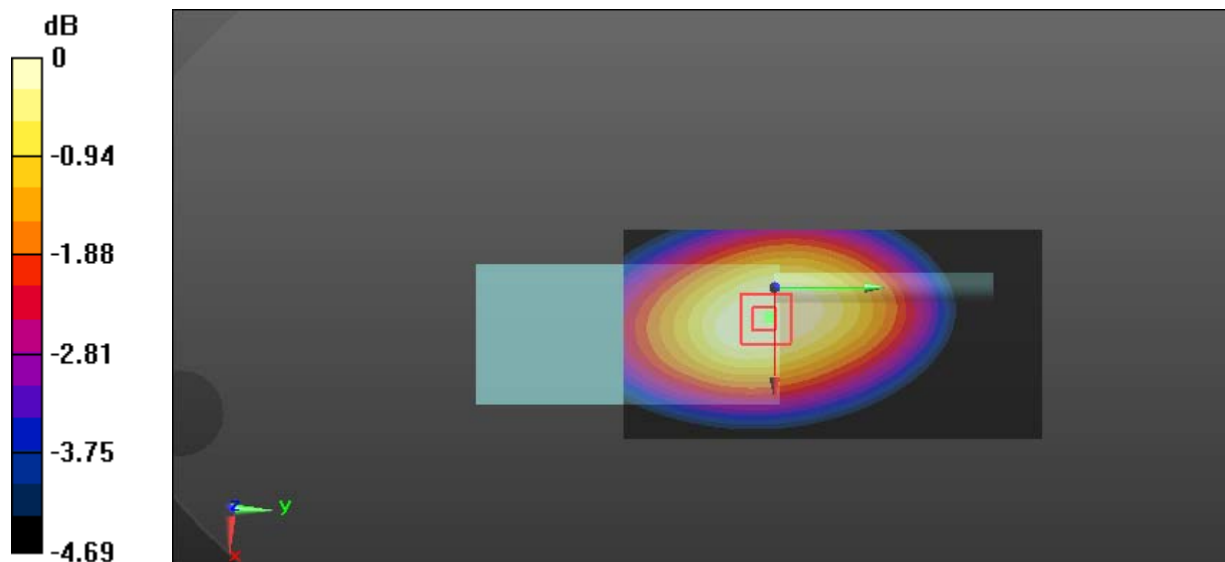

0 dB = 9.07 W/kg = 9.58 dBW/kg

**Test Plot 10#: PTT\_FM 25kHz\_Body Back\_362.5125 MHz****DUT: HP782 Uv; Type: Digital Portable Radio; Serial: 19052100220**

Communication System: FM; Frequency: 362.512 MHz; Duty Cycle: 1:1

Medium parameters used:  $f = 362.512$  MHz;  $\sigma = 0.906$  S/m;  $\epsilon_r = 58.169$ ;  $\rho = 1000$  kg/m<sup>3</sup>

Phantom section: Flat Section

DASY5 Configuration:

- Probe: ES3DV2 - SN3019; ConvF(7.1, 7.1, 7.1); Calibrated: 2018/8/20;
- Sensor-Surface: 4mm (Mechanical Surface Detection)
- Electronics: DAE3 Sn471; Calibrated: 2018/12/3
- Phantom: ELI v8.0; Type: QDOVA004AA; Serial: 2051
- Measurement SW: DASY52, Version 52.8 (8);

**Area Scan (61x121x1):** Interpolated grid: dx=1.500 mm, dy=1.500 mm

Maximum value of SAR (interpolated) = 9.51 W/kg

**Zoom Scan (6x6x7)/Cube 0:** Measurement grid: dx=8mm, dy=8mm, dz=5mm

Reference Value = 101.2 V/m; Power Drift = -0.04 dB

Peak SAR (extrapolated) = 11.2 W/kg

**SAR(1 g) = 9.12 W/kg; SAR(10 g) = 7.47 W/kg**

Maximum value of SAR (measured) = 9.43 W/kg

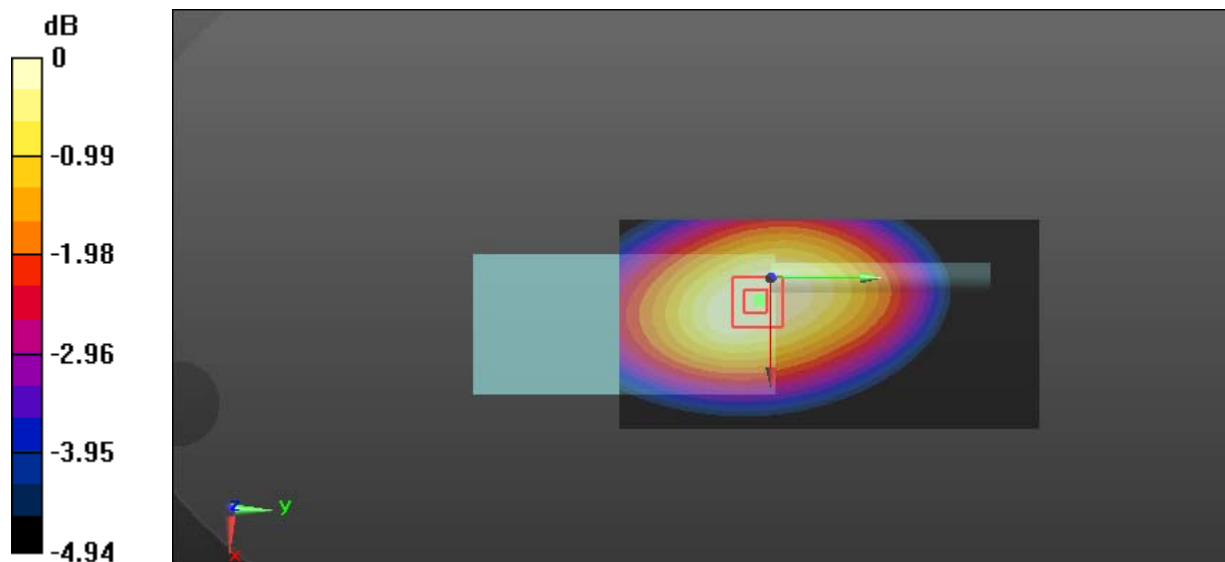

0 dB = 9.43 W/kg = 9.75 dBW/kg

**Test Plot 11#: PTT\_FM 25kHz\_Body Back\_375.0125 MHz****DUT: HP782 Uv; Type: Digital Portable Radio; Serial: 19052100220**

Communication System: FM; Frequency: 375.012 MHz; Duty Cycle: 1:1

Medium parameters used:  $f = 375.012$  MHz;  $\sigma = 0.911$  S/m;  $\epsilon_r = 58.023$ ;  $\rho = 1000$  kg/m<sup>3</sup>

Phantom section: Flat Section

DASY5 Configuration:

- Probe: ES3DV2 - SN3019; ConvF(7.1, 7.1, 7.1); Calibrated: 2018/8/20;
- Sensor-Surface: 4mm (Mechanical Surface Detection)
- Electronics: DAE3 Sn471; Calibrated: 2018/12/3
- Phantom: ELI v8.0; Type: QDOVA004AA; Serial: 2051
- Measurement SW: DASY52, Version 52.8 (8);

**Area Scan (61x121x1):** Interpolated grid: dx=1.500 mm, dy=1.500 mm

Maximum value of SAR (interpolated) = 6.37 W/kg

**Zoom Scan (5x5x7)/Cube 0:** Measurement grid: dx=8mm, dy=8mm, dz=5mm

Reference Value = 80.99 V/m; Power Drift = -0.08 dB

Peak SAR (extrapolated) = 7.50 W/kg

**SAR(1 g) = 6.06 W/kg; SAR(10 g) = 4.87 W/kg**

Maximum value of SAR (measured) = 6.28 W/kg

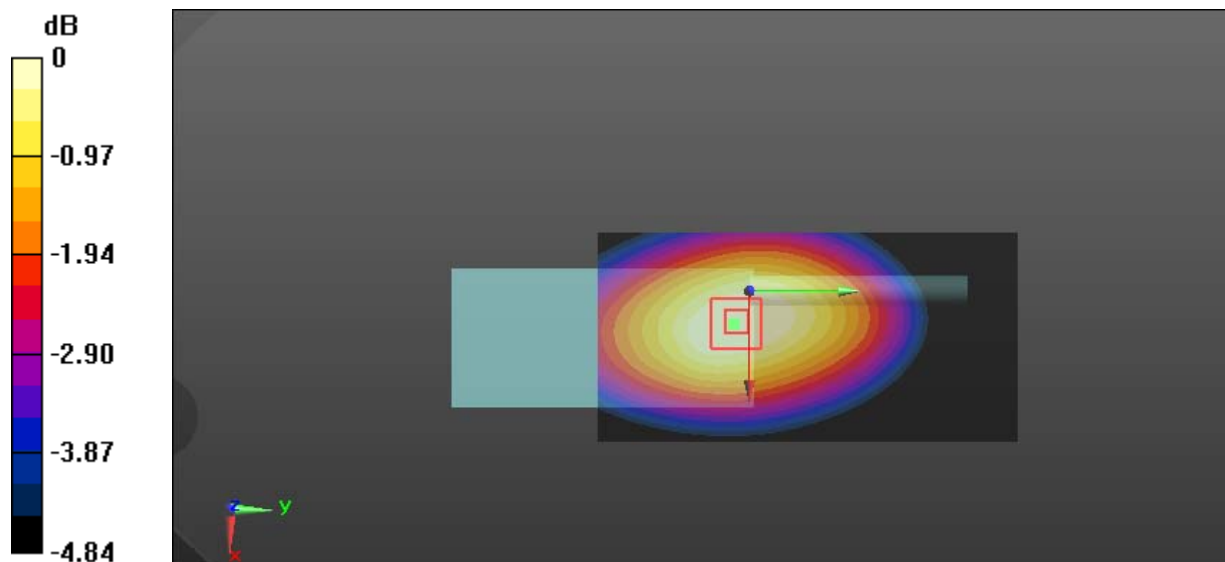

0 dB = 6.28 W/kg = 7.98 dBW/kg

**Test Plot 12#: PTT\_FM 25kHz\_Body Back\_387.4875 MHz****DUT: HP782 Uv; Type: Digital Portable Radio; Serial: 19052100220**

Communication System: FM; Frequency: 387.488 MHz; Duty Cycle: 1:1

Medium parameters used:  $f = 387.488$  MHz;  $\sigma = 0.915$  S/m;  $\epsilon_r = 57.854$ ;  $\rho = 1000$  kg/m<sup>3</sup>

Phantom section: Flat Section

DASY5 Configuration:

- Probe: ES3DV2 - SN3019; ConvF(7.1, 7.1, 7.1); Calibrated: 2018/8/20;
- Sensor-Surface: 4mm (Mechanical Surface Detection)
- Electronics: DAE3 Sn471; Calibrated: 2018/12/3
- Phantom: ELI v8.0; Type: QDOVA004AA; Serial: 2051
- Measurement SW: DASY52, Version 52.8 (8);

**Area Scan (61x121x1):** Interpolated grid: dx=1.500 mm, dy=1.500 mm

Maximum value of SAR (interpolated) = 3.57 W/kg

**Zoom Scan (6x6x7)/Cube 0:** Measurement grid: dx=8mm, dy=8mm, dz=5mm

Reference Value = 60.85 V/m; Power Drift = -0.11 dB

Peak SAR (extrapolated) = 4.20 W/kg

**SAR(1 g) = 3.37 W/kg; SAR(10 g) = 2.68 W/kg**

Maximum value of SAR (measured) = 3.49 W/kg

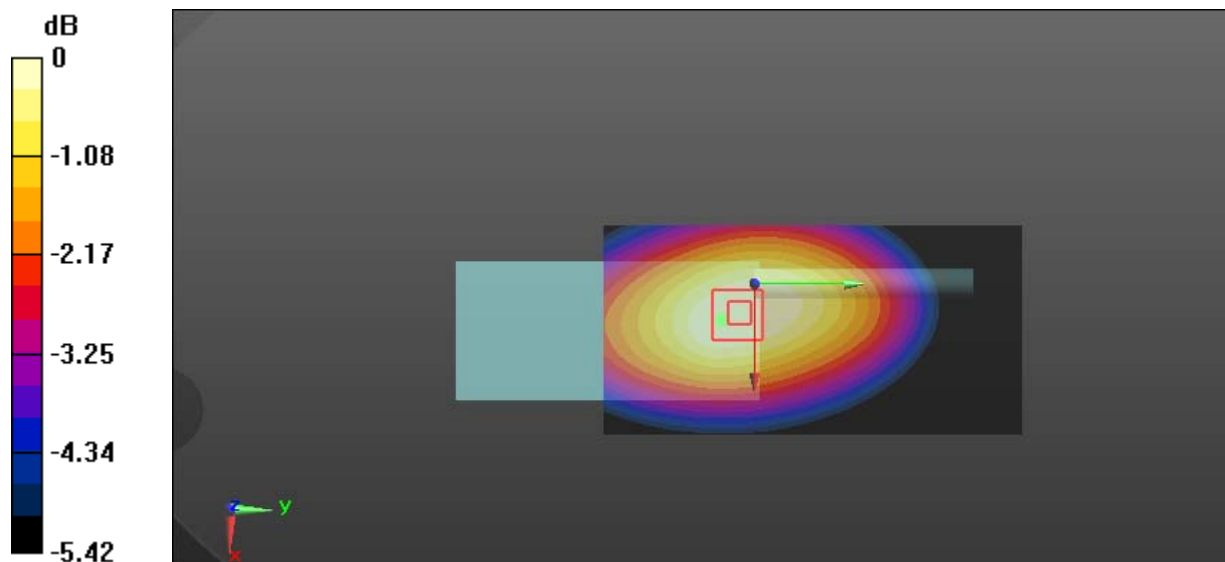

0 dB = 3.49 W/kg = 5.43 dBW/kg

**Test Plot 13#: PTT\_FM 25kHz\_Body Back\_399.9875 MHz****DUT: HP782 Uv; Type: Digital Portable Radio; Serial: 19052100220**

Communication System: FM; Frequency: 399.988 MHz; Duty Cycle: 1:1

Medium parameters used:  $f = 399.988$  MHz;  $\sigma = 0.918$  S/m;  $\epsilon_r = 57.697$ ;  $\rho = 1000$  kg/m<sup>3</sup>

Phantom section: Flat Section

DASY5 Configuration:

- Probe: ES3DV2 - SN3019; ConvF(7.1, 7.1, 7.1); Calibrated: 2018/8/20;
- Sensor-Surface: 4mm (Mechanical Surface Detection)
- Electronics: DAE3 Sn471; Calibrated: 2018/12/3
- Phantom: ELI v8.0; Type: QDOVA004AA; Serial: 2051
- Measurement SW: DASY52, Version 52.8 (8);

**Area Scan (61x121x1):** Interpolated grid: dx=1.500 mm, dy=1.500 mm

Maximum value of SAR (interpolated) = 2.57 W/kg

**Zoom Scan (6x6x7)/Cube 0:** Measurement grid: dx=8mm, dy=8mm, dz=5mm

Reference Value = 50.99 V/m; Power Drift = -0.05 dB

Peak SAR (extrapolated) = 3.08 W/kg

**SAR(1 g) = 2.44 W/kg; SAR(10 g) = 1.92 W/kg**

Maximum value of SAR (measured) = 2.55 W/kg

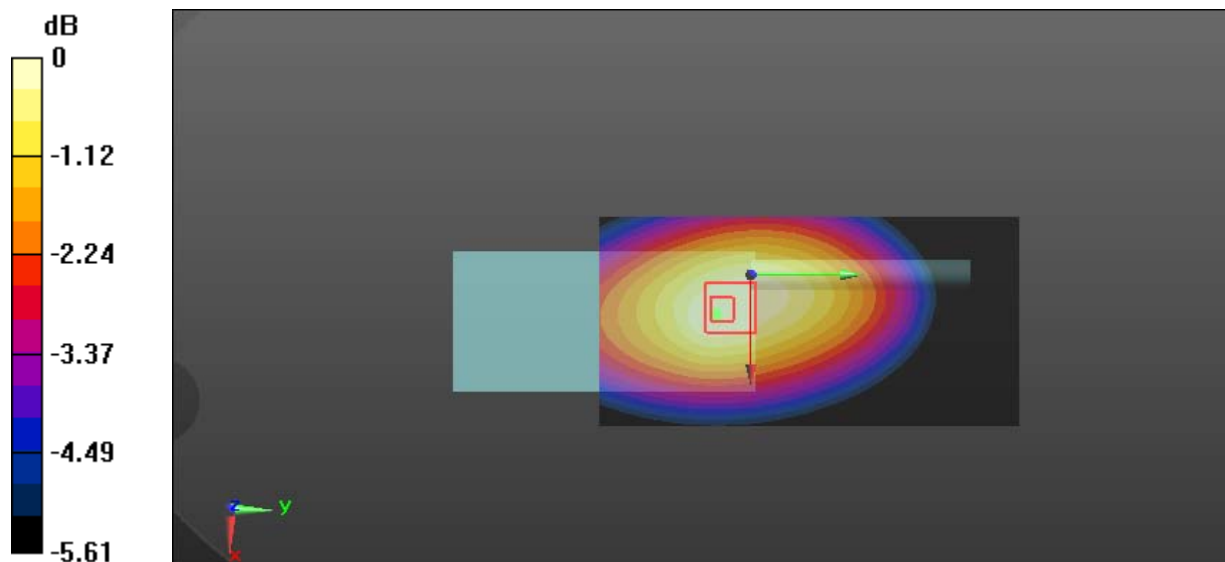

0 dB = 2.55 W/kg = 4.07 dBW/kg

**Test Plot 14#: PTT\_4FSK 12.5kHz\_Body Back\_350.0125 MHz****DUT: HP782 Uv; Type: Digital Portable Radio; Serial: 19052100220**

Communication System: 4FSK; Frequency: 350.012 MHz; Duty Cycle: 1:2

Medium parameters used:  $f = 350.012$  MHz;  $\sigma = 0.901$  S/m;  $\epsilon_r = 58.327$ ;  $\rho = 1000$  kg/m<sup>3</sup>

Phantom section: Flat Section

DASY5 Configuration:

- Probe: ES3DV2 - SN3019; ConvF(7.1, 7.1, 7.1); Calibrated: 2018/8/20;
- Sensor-Surface: 4mm (Mechanical Surface Detection)
- Electronics: DAE3 Sn471; Calibrated: 2018/12/3
- Phantom: ELI v8.0; Type: QDOVA004AA; Serial: 2051
- Measurement SW: DASY52, Version 52.8 (8);

**Area Scan (61x121x1):** Interpolated grid: dx=1.500 mm, dy=1.500 mm

Maximum value of SAR (interpolated) = 5.04 W/kg

**Zoom Scan (5x5x7)/Cube 0:** Measurement grid: dx=8mm, dy=8mm, dz=5mm

Reference Value = 73.58 V/m; Power Drift = -0.09 dB

Peak SAR (extrapolated) = 6.25 W/kg

**SAR(1 g) = 4.72 W/kg; SAR(10 g) = 3.88 W/kg**

Maximum value of SAR (measured) = 5.04 W/kg

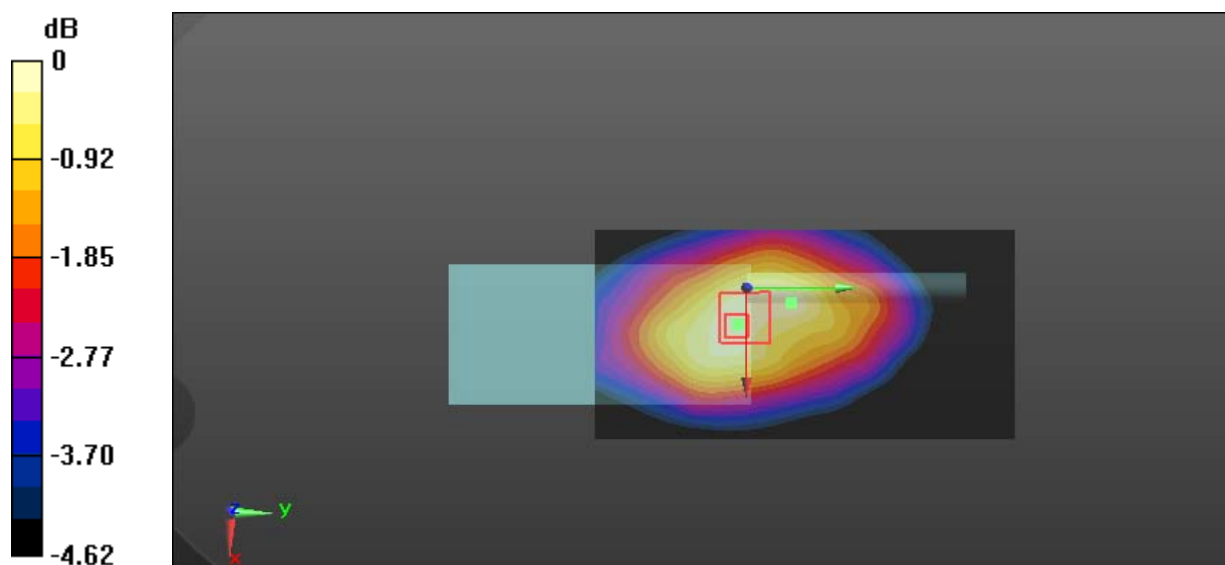

0 dB = 5.04 W/kg = 7.02 dBW/kg

**Test Plot 15#: PTT\_FM 12.5kHz\_Face Up\_435.0125 MHz****DUT: HP782 Uv; Type: Digital Portable Radio; Serial: 19052100220**

Communication System: FM; Frequency: 435.012 MHz; Duty Cycle: 1:1

Medium parameters used:  $f = 435.012$  MHz;  $\sigma = 0.877$  S/m;  $\epsilon_r = 43.982$ ;  $\rho = 1000$  kg/m<sup>3</sup>

Phantom section: Flat Section

DASY5 Configuration:

- Probe: ES3DV2 - SN3019; ConvF(7.18, 7.18, 7.18); Calibrated: 2018/8/20;
- Sensor-Surface: 4mm (Mechanical Surface Detection)
- Electronics: DAE3 Sn471; Calibrated: 2018/12/3
- Phantom: ELI v8.0; Type: QDOVA004AA; Serial: 2051
- Measurement SW: DASY52, Version 52.8 (8);

**Area Scan (61x121x1):** Interpolated grid: dx=1.500 mm, dy=1.500 mm

Maximum value of SAR (interpolated) = 7.29 W/kg

**Zoom Scan (5x5x7)/Cube 0:** Measurement grid: dx=8mm, dy=8mm, dz=5mm

Reference Value = 92.87 V/m; Power Drift = -0.01 dB

Peak SAR (extrapolated) = 8.01 W/kg

**SAR(1 g) = 6.67 W/kg; SAR(10 g) = 5.1 W/kg**

Maximum value of SAR (measured) = 7.02 W/kg

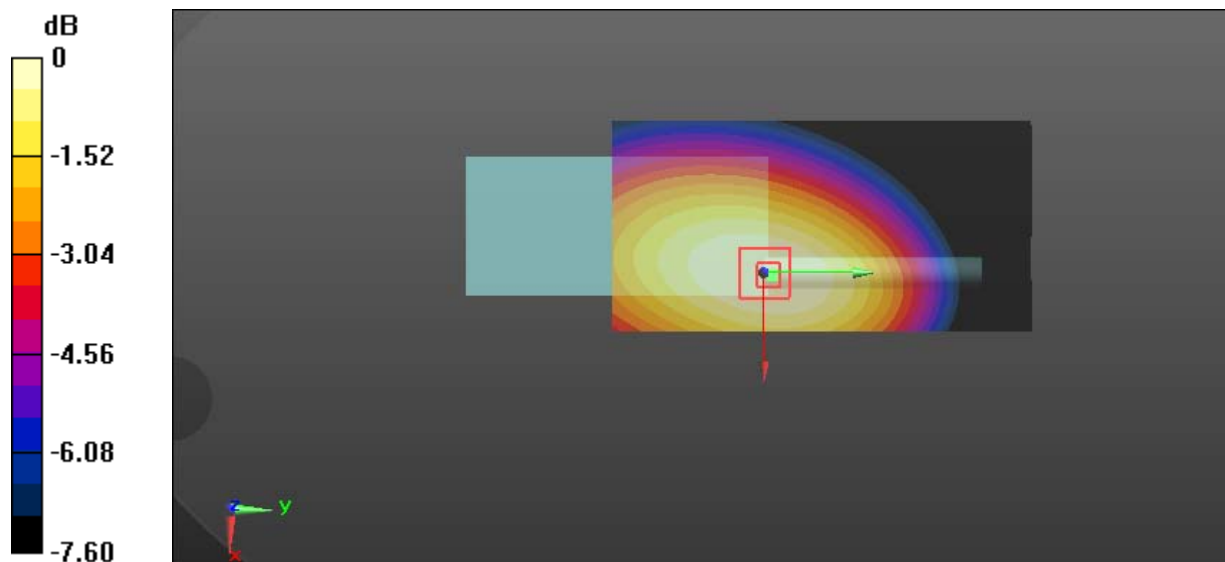

0 dB = 7.02 W/kg = 8.46 dBW/kg

**Test Plot 16#: PTT\_FM 25kHz\_Face Up\_435.0125 MHz****DUT: HP782 Uv; Type: Digital Portable Radio; Serial: 19052100220**

Communication System: FM; Frequency: 435.012 MHz; Duty Cycle: 1:1

Medium parameters used:  $f = 435.012$  MHz;  $\sigma = 0.877$  S/m;  $\epsilon_r = 43.982$ ;  $\rho = 1000$  kg/m<sup>3</sup>

Phantom section: Flat Section

DASY5 Configuration:

- Probe: ES3DV2 - SN3019; ConvF(7.18, 7.18, 7.18); Calibrated: 2018/8/20;
- Sensor-Surface: 4mm (Mechanical Surface Detection)
- Electronics: DAE3 Sn471; Calibrated: 2018/12/3
- Phantom: ELI v8.0; Type: QDOVA004AA; Serial: 2051
- Measurement SW: DASY52, Version 52.8 (8);

**Area Scan (61x121x1):** Interpolated grid: dx=1.500 mm, dy=1.500 mm

Maximum value of SAR (interpolated) = 6.77 W/kg

**Zoom Scan (5x5x7)/Cube 0:** Measurement grid: dx=8mm, dy=8mm, dz=5mm

Reference Value = 87.48 V/m; Power Drift = -0.11 dB

Peak SAR (extrapolated) = 7.54 W/kg

**SAR(1 g) = 6.28 W/kg; SAR(10 g) = 4.81 W/kg**

Maximum value of SAR (measured) = 6.61 W/kg

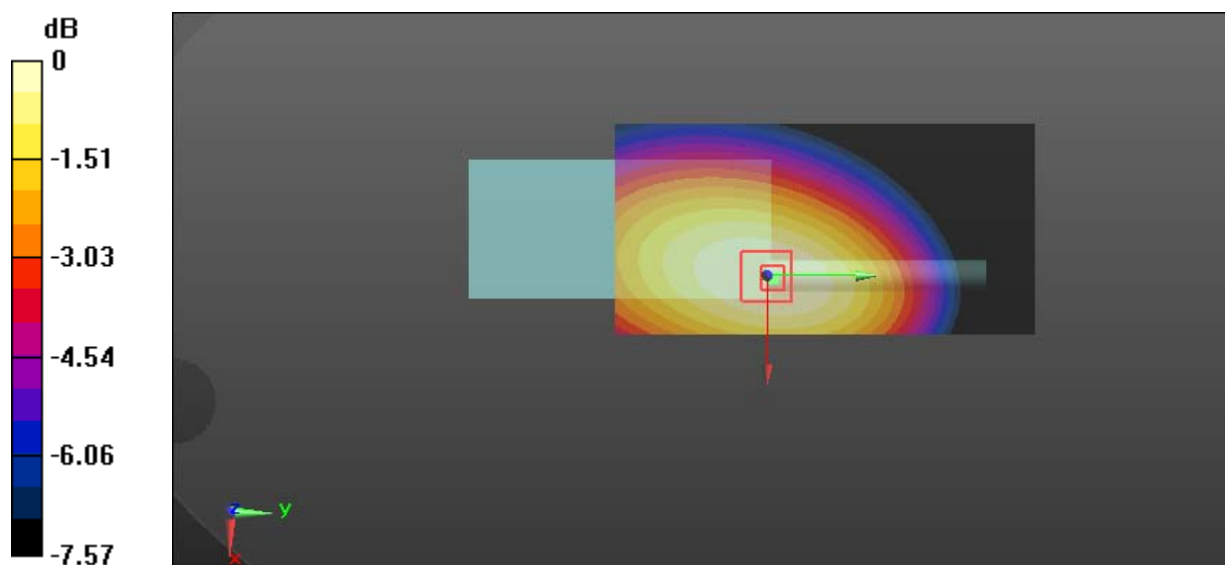

0 dB = 6.61 W/kg = 8.20 dBW/kg



**Test Plot 17#: PTT\_4FSK 12.5kHz\_Face Up\_435.0125 MHz****DUT: HP782 Uv; Type: Digital Portable Radio; Serial: 19052100220**

Communication System: 4FSK; Frequency: 435.012 MHz; Duty Cycle: 1:2

Medium parameters used:  $f = 435.012$  MHz;  $\sigma = 0.877$  S/m;  $\epsilon_r = 43.982$ ;  $\rho = 1000$  kg/m<sup>3</sup>

Phantom section: Flat Section

DASY5 Configuration:

- Probe: ES3DV2 - SN3019; ConvF(7.18, 7.18, 7.18); Calibrated: 2018/8/20;
- Sensor-Surface: 4mm (Mechanical Surface Detection)
- Electronics: DAE3 Sn471; Calibrated: 2018/12/3
- Phantom: ELI v8.0; Type: QDOVA004AA; Serial: 2051
- Measurement SW: DASY52, Version 52.8 (8);

**Area Scan (61x121x1):** Interpolated grid: dx=1.500 mm, dy=1.500 mm

Maximum value of SAR (interpolated) = 3.95 W/kg

**Zoom Scan (6x6x7)/Cube 0:** Measurement grid: dx=8mm, dy=8mm, dz=5mm

Reference Value = 67.93 V/m; Power Drift = -0.00 dB

Peak SAR (extrapolated) = 5.48 W/kg

**SAR(1 g) = 3.81 W/kg; SAR(10 g) = 2.96 W/kg**

Maximum value of SAR (measured) = 4.01 W/kg

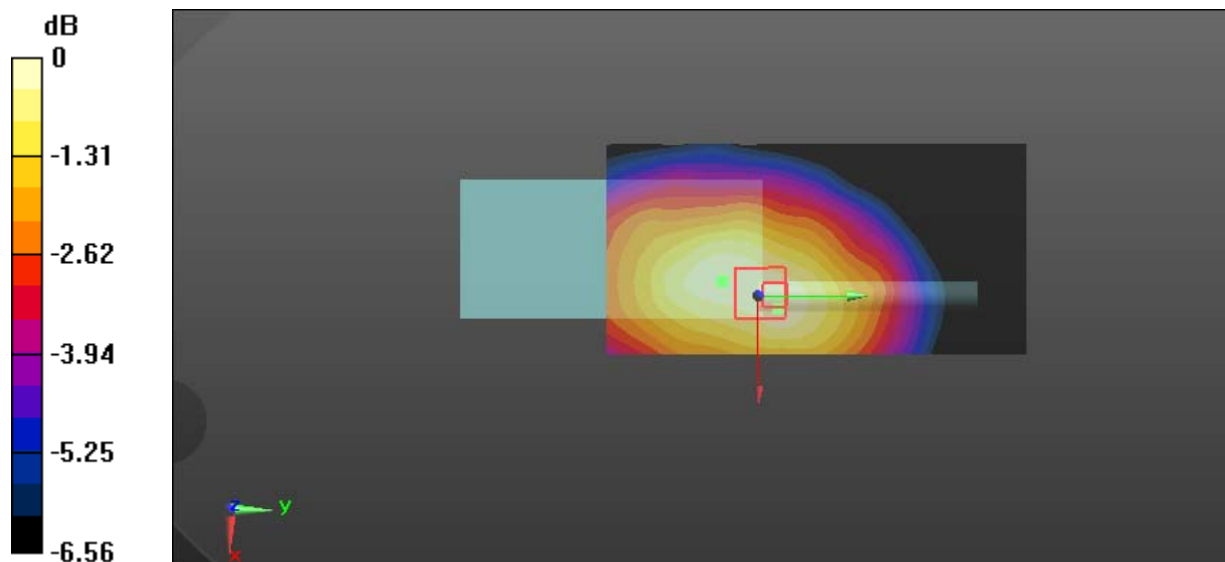

0 dB = 4.01 W/kg = 6.03 dBW/kg

**Test Plot 18#: PTT\_FM 12.5kHz\_Body Back\_400.0125 MHz****DUT: HP782 Uv; Type: Digital Portable Radio; Serial: 19052100220**

Communication System: FM; Frequency: 400.012 MHz; Duty Cycle: 1:1

Medium parameters used:  $f = 400.012$  MHz;  $\sigma = 0.919$  S/m;  $\epsilon_r = 57.696$ ;  $\rho = 1000$  kg/m<sup>3</sup>

Phantom section: Flat Section

DASY5 Configuration:

- Probe: ES3DV2 - SN3019; ConvF(7.1, 7.1, 7.1); Calibrated: 2018/8/20;
- Sensor-Surface: 4mm (Mechanical Surface Detection)
- Electronics: DAE3 Sn471; Calibrated: 2018/12/3
- Phantom: ELI v8.0; Type: QDOVA004AA; Serial: 2051
- Measurement SW: DASY52, Version 52.8 (8);

**Area Scan (61x121x1):** Interpolated grid: dx=1.500 mm, dy=1.500 mm

Maximum value of SAR (interpolated) = 11.8 W/kg

**Zoom Scan (5x5x7)/Cube 0:** Measurement grid: dx=8mm, dy=8mm, dz=5mm

Reference Value = 115.2 V/m; Power Drift = -0.09 dB

Peak SAR (extrapolated) = 13.3 W/kg

**SAR(1 g) = 10.8 W/kg; SAR(10 g) = 8.47 W/kg**

Maximum value of SAR (measured) = 11.2 W/kg

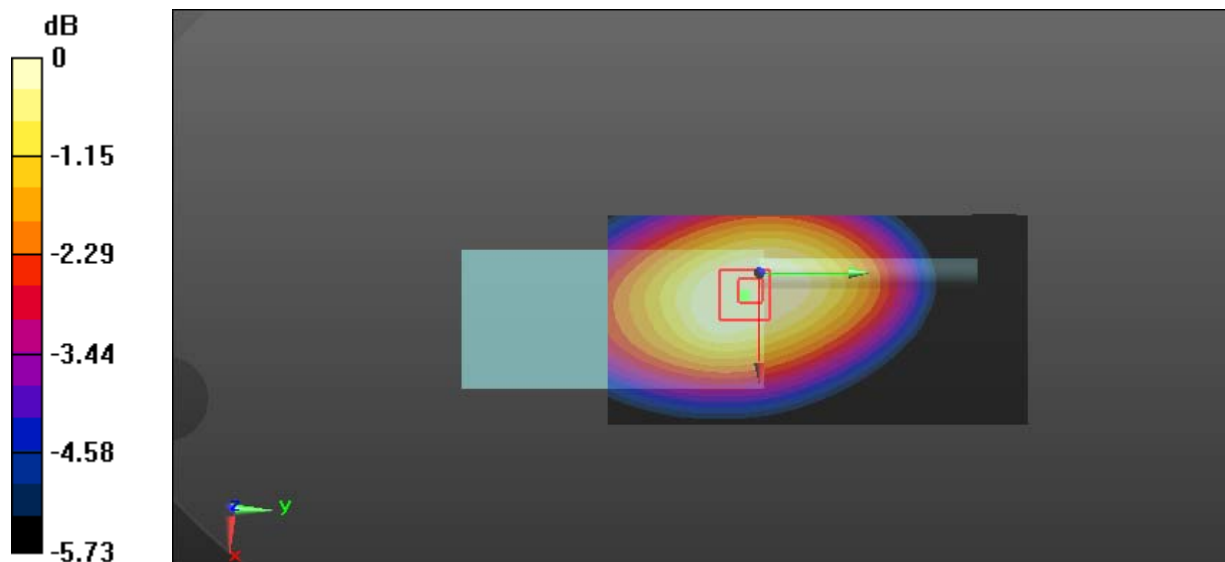

0 dB = 11.2 W/kg = 10.49 dBW/kg

**Test Plot 19#: PTT\_FM 12.5kHz\_Body Back\_417.5125 MHz****DUT: HP782 Uv; Type: Digital Portable Radio; Serial: 19052100220**

Communication System: FM; Frequency: 417.512 MHz; Duty Cycle: 1:1

Medium parameters used:  $f = 417.512$  MHz;  $\sigma = 0.926$  S/m;  $\epsilon_r = 57.476$ ;  $\rho = 1000$  kg/m<sup>3</sup>

Phantom section: Flat Section

DASY5 Configuration:

- Probe: ES3DV2 - SN3019; ConvF(7.1, 7.1, 7.1); Calibrated: 2018/8/20;
- Sensor-Surface: 4mm (Mechanical Surface Detection)
- Electronics: DAE3 Sn471; Calibrated: 2018/12/3
- Phantom: ELI v8.0; Type: QDOVA004AA; Serial: 2051
- Measurement SW: DASY52, Version 52.8 (8);

**Area Scan (61x121x1):** Interpolated grid: dx=1.500 mm, dy=1.500 mm

Maximum value of SAR (interpolated) = 11.7 W/kg

**Zoom Scan (5x5x7)/Cube 0:** Measurement grid: dx=8mm, dy=8mm, dz=5mm

Reference Value = 113.8 V/m; Power Drift = -0.16 dB

Peak SAR (extrapolated) = 13.6 W/kg

**SAR(1 g) = 11 W/kg; SAR(10 g) = 8.66 W/kg**

Maximum value of SAR (measured) = 11.5 W/kg

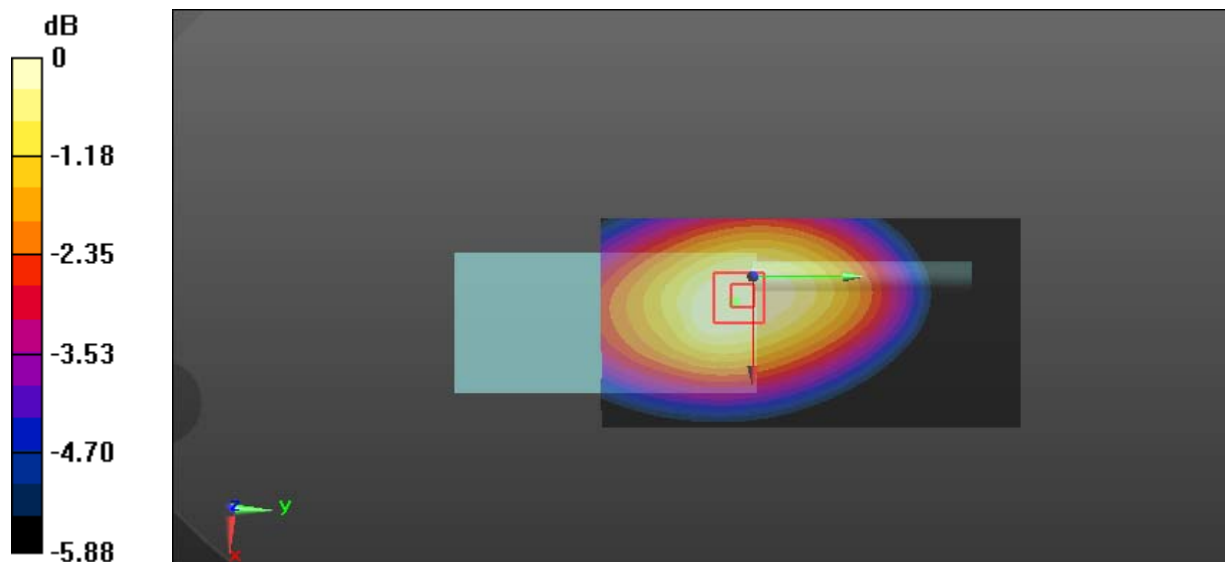

0 dB = 11.5 W/kg = 10.61 dBW/kg

**Test Plot 20#: PTT\_FM 12.5kHz\_Body Back\_435.0125 MHz****DUT: HP782 Uv; Type: Digital Portable Radio; Serial: 19052100220**

Communication System: FM; Frequency: 435.012 MHz; Duty Cycle: 1:1

Medium parameters used:  $f = 435.012$  MHz;  $\sigma = 0.932$  S/m;  $\epsilon_r = 57.255$ ;  $\rho = 1000$  kg/m<sup>3</sup>

Phantom section: Flat Section

DASY5 Configuration:

- Probe: ES3DV2 - SN3019; ConvF(7.1, 7.1, 7.1); Calibrated: 2018/8/20;
- Sensor-Surface: 4mm (Mechanical Surface Detection)
- Electronics: DAE3 Sn471; Calibrated: 2018/12/3
- Phantom: ELI v8.0; Type: QDOVA004AA; Serial: 2051
- Measurement SW: DASY52, Version 52.8 (8);

**Area Scan (61x121x1):** Interpolated grid: dx=1.500 mm, dy=1.500 mm

Maximum value of SAR (interpolated) = 11.9 W/kg

**Zoom Scan (5x5x7)/Cube 0:** Measurement grid: dx=8mm, dy=8mm, dz=5mm

Reference Value = 113.4 V/m; Power Drift = -0.11 dB

Peak SAR (extrapolated) = 13.9 W/kg

**SAR(1 g) = 11.2 W/kg; SAR(10 g) = 8.79 W/kg**

Maximum value of SAR (measured) = 11.7 W/kg

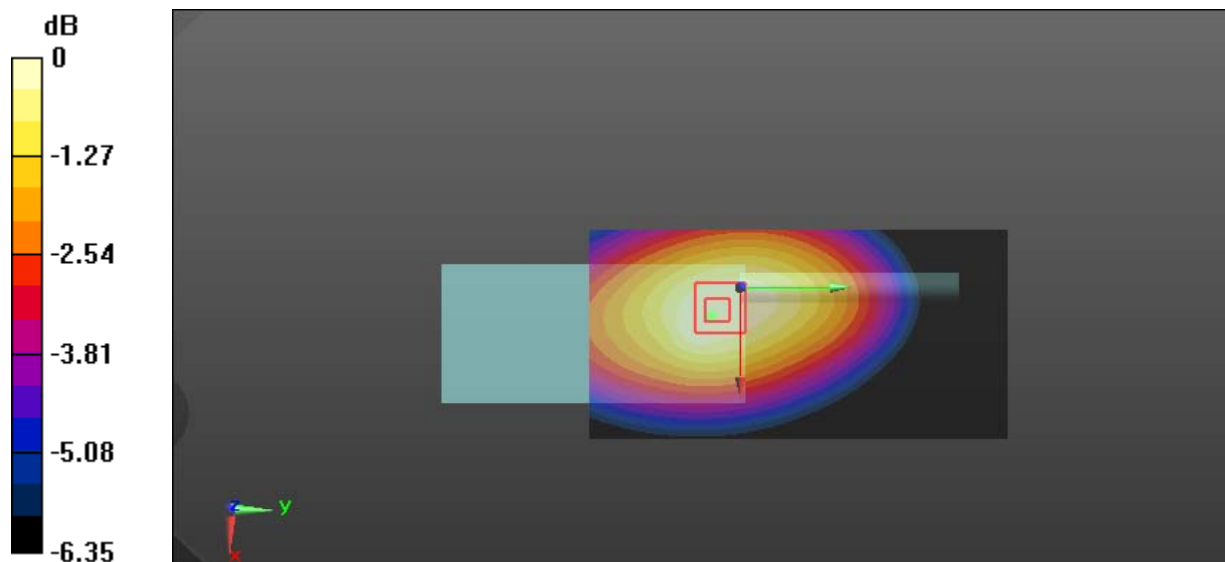

0 dB = 11.7 W/kg = 10.68 dBW/kg

**Test Plot 21#: PTT\_FM 12.5kHz\_Body Back\_452.4875 MHz****DUT: HP782 Uv; Type: Digital Portable Radio; Serial: 19052100220**

Communication System: FM; Frequency: 452.488 MHz; Duty Cycle: 1:1

Medium parameters used:  $f = 452.488$  MHz;  $\sigma = 0.939$  S/m;  $\epsilon_r = 57.039$ ;  $\rho = 1000$  kg/m<sup>3</sup>

Phantom section: Flat Section

DASY5 Configuration:

- Probe: ES3DV2 - SN3019; ConvF(7.1, 7.1, 7.1); Calibrated: 2018/8/20;
- Sensor-Surface: 4mm (Mechanical Surface Detection)
- Electronics: DAE3 Sn471; Calibrated: 2018/12/3
- Phantom: ELI v8.0; Type: QDOVA004AA; Serial: 2051
- Measurement SW: DASY52, Version 52.8 (8);

**Area Scan (61x121x1):** Interpolated grid: dx=1.500 mm, dy=1.500 mm

Maximum value of SAR (interpolated) = 11.2 W/kg

**Zoom Scan (5x5x7)/Cube 0:** Measurement grid: dx=8mm, dy=8mm, dz=5mm

Reference Value = 108.8 V/m; Power Drift = -0.14 dB

Peak SAR (extrapolated) = 13.1 W/kg

**SAR(1 g) = 10.5 W/kg; SAR(10 g) = 8.14 W/kg**

Maximum value of SAR (measured) = 11.0 W/kg

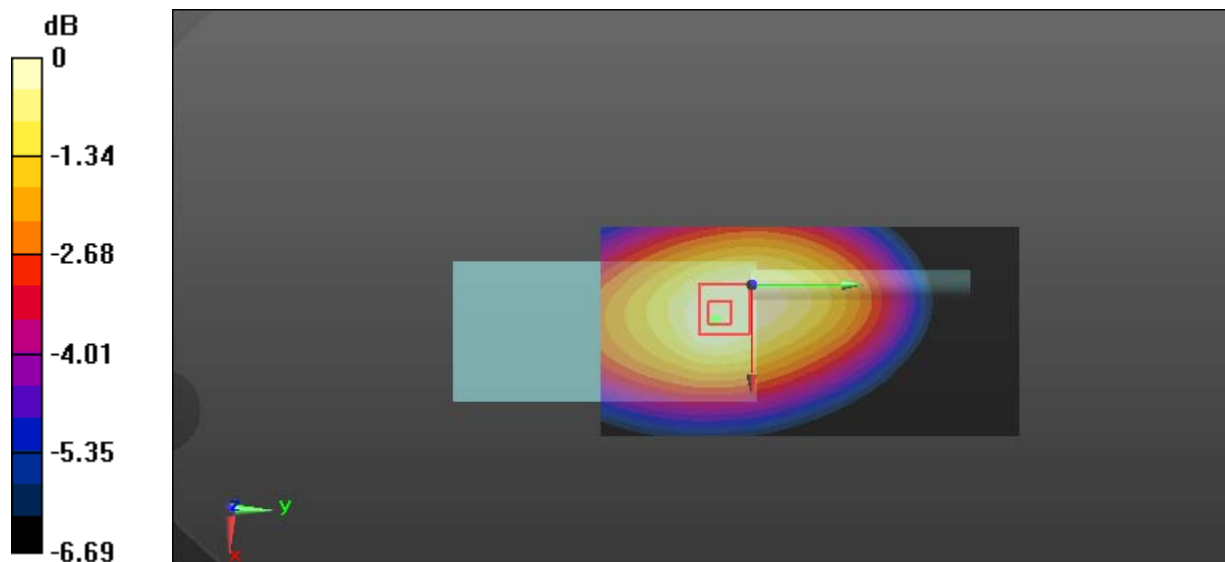

0 dB = 11.0 W/kg = 10.41 dBW/kg

**Test Plot 22#: PTT\_FM 12.5kHz\_Body Back\_469.9875 MHz****DUT: HP782 Uv; Type: Digital Portable Radio; Serial: 19052100220**

Communication System: FM; Frequency: 469.988 MHz; Duty Cycle: 1:1

Medium parameters used:  $f = 469.988$  MHz;  $\sigma = 0.945$  S/m;  $\epsilon_r = 56.825$ ;  $\rho = 1000$  kg/m<sup>3</sup>

Phantom section: Flat Section

DASY5 Configuration:

- Probe: ES3DV2 - SN3019; ConvF(7.1, 7.1, 7.1); Calibrated: 2018/8/20;
- Sensor-Surface: 4mm (Mechanical Surface Detection)
- Electronics: DAE3 Sn471; Calibrated: 2018/12/3
- Phantom: ELI v8.0; Type: QDOVA004AA; Serial: 2051
- Measurement SW: DASY52, Version 52.8 (8);

**Area Scan (61x121x1):** Interpolated grid: dx=1.500 mm, dy=1.500 mm

Maximum value of SAR (interpolated) = 8.22 W/kg

**Zoom Scan (5x5x7)/Cube 0:** Measurement grid: dx=8mm, dy=8mm, dz=5mm

Reference Value = 92.48 V/m; Power Drift = -0.18 dB

Peak SAR (extrapolated) = 9.76 W/kg

**SAR(1 g) = 7.78 W/kg; SAR(10 g) = 6.02 W/kg**

Maximum value of SAR (measured) = 8.13 W/kg

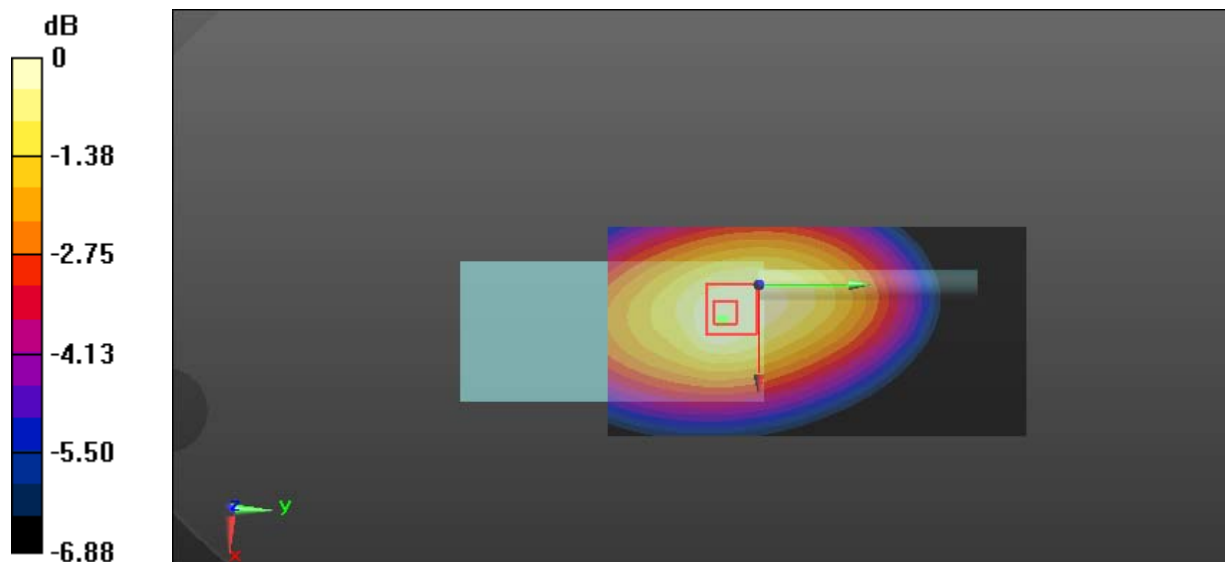

0 dB = 8.13 W/kg = 9.10 dBW/kg

**Test Plot 23#: PTT\_FM 25kHz\_Body Back\_400.0125 MHz****DUT: HP782 Uv; Type: Digital Portable Radio; Serial: 19052100220**

Communication System: FM; Frequency: 400.012 MHz; Duty Cycle: 1:1

Medium parameters used:  $f = 400.012$  MHz;  $\sigma = 0.919$  S/m;  $\epsilon_r = 57.696$ ;  $\rho = 1000$  kg/m<sup>3</sup>

Phantom section: Flat Section

DASY5 Configuration:

- Probe: ES3DV2 - SN3019; ConvF(7.1, 7.1, 7.1); Calibrated: 2018/8/20;
- Sensor-Surface: 4mm (Mechanical Surface Detection)
- Electronics: DAE3 Sn471; Calibrated: 2018/12/3
- Phantom: ELI v8.0; Type: QDOVA004AA; Serial: 2051
- Measurement SW: DASY52, Version 52.8 (8);

**Area Scan (61x121x1):** Interpolated grid: dx=1.500 mm, dy=1.500 mm

Maximum value of SAR (interpolated) = 11.2 W/kg

**Zoom Scan (5x5x7)/Cube 0:** Measurement grid: dx=8mm, dy=8mm, dz=5mm

Reference Value = 110.2 V/m; Power Drift = -0.13 dB

Peak SAR (extrapolated) = 12.8 W/kg

**SAR(1 g) = 10.2 W/kg; SAR(10 g) = 7.91 W/kg**

Maximum value of SAR (measured) = 10.6 W/kg

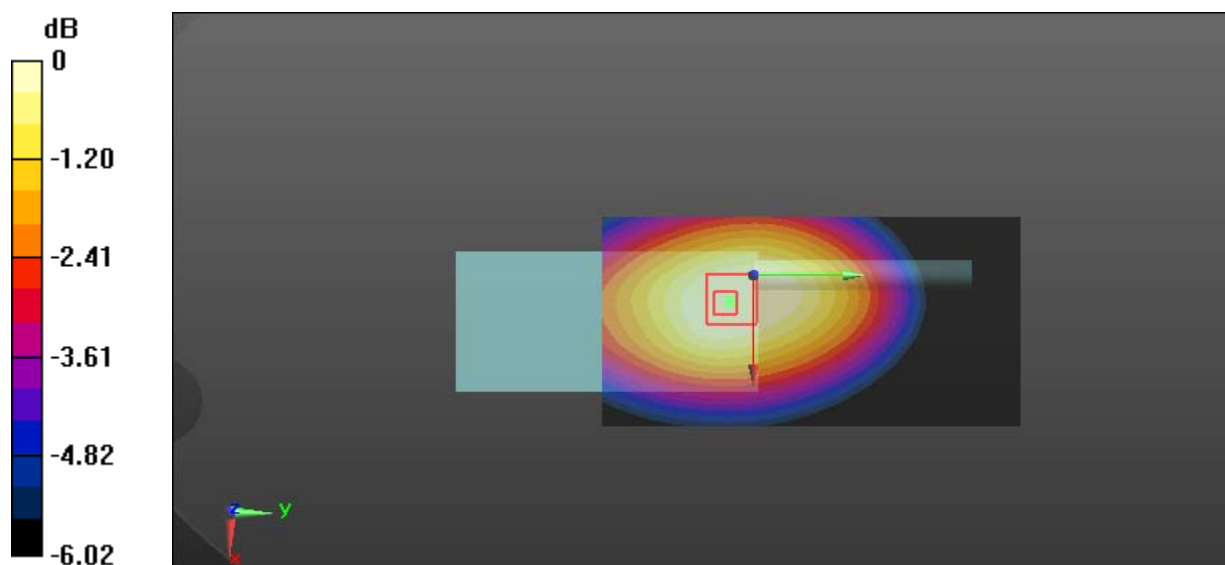

0 dB = 10.6 W/kg = 10.25 dBW/kg

**Test Plot 24#: PTT\_FM 25kHz\_Body Back\_417.5125 MHz****DUT: HP782 Uv; Type: Digital Portable Radio; Serial: 19052100220**

Communication System: FM; Frequency: 417.512 MHz; Duty Cycle: 1:1

Medium parameters used:  $f = 417.512$  MHz;  $\sigma = 0.926$  S/m;  $\epsilon_r = 57.476$ ;  $\rho = 1000$  kg/m<sup>3</sup>

Phantom section: Flat Section

DASY5 Configuration:

- Probe: ES3DV2 - SN3019; ConvF(7.1, 7.1, 7.1); Calibrated: 2018/8/20;
- Sensor-Surface: 4mm (Mechanical Surface Detection)
- Electronics: DAE3 Sn471; Calibrated: 2018/12/3
- Phantom: ELI v8.0; Type: QDOVA004AA; Serial: 2051
- Measurement SW: DASY52, Version 52.8 (8);

**Area Scan (61x121x1):** Interpolated grid: dx=1.500 mm, dy=1.500 mm

Maximum value of SAR (interpolated) = 11.0 W/kg

**Zoom Scan (5x5x7)/Cube 0:** Measurement grid: dx=8mm, dy=8mm, dz=5mm

Reference Value = 110.4 V/m; Power Drift = -0.16 dB

Peak SAR (extrapolated) = 13.2 W/kg

**SAR(1 g) = 10.4 W/kg; SAR(10 g) = 8.1 W/kg**

Maximum value of SAR (measured) = 10.8 W/kg

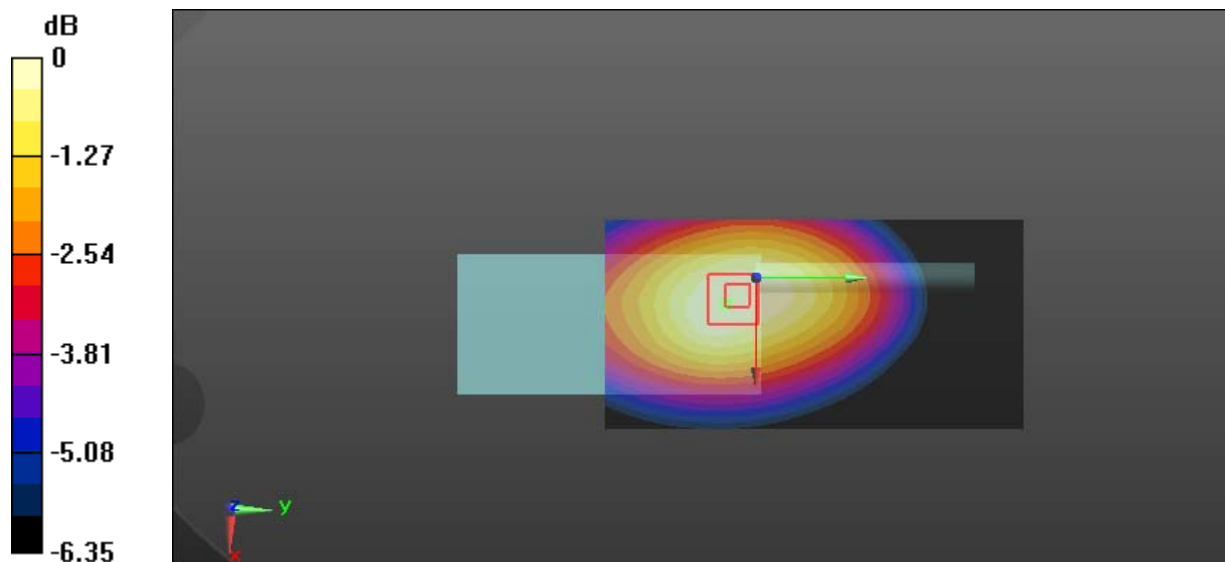

0 dB = 10.8 W/kg = 10.33 dBW/kg



**Test Plot 25#: PTT\_FM 25kHz\_Body Back\_435.0125 MHz****DUT: HP782 Uv; Type: Digital Portable Radio; Serial: 19052100220**

Communication System: FM; Frequency: 435.012 MHz; Duty Cycle: 1:1

Medium parameters used:  $f = 435.012$  MHz;  $\sigma = 0.932$  S/m;  $\epsilon_r = 57.255$ ;  $\rho = 1000$  kg/m<sup>3</sup>

Phantom section: Flat Section

DASY5 Configuration:

- Probe: ES3DV2 - SN3019; ConvF(7.1, 7.1, 7.1); Calibrated: 2018/8/20;
- Sensor-Surface: 4mm (Mechanical Surface Detection)
- Electronics: DAE3 Sn471; Calibrated: 2018/12/3
- Phantom: ELI v8.0; Type: QDOVA004AA; Serial: 2051
- Measurement SW: DASY52, Version 52.8 (8);

**Area Scan (61x121x1):** Interpolated grid: dx=1.500 mm, dy=1.500 mm

Maximum value of SAR (interpolated) = 11.3 W/kg

**Zoom Scan (5x5x7)/Cube 0:** Measurement grid: dx=8mm, dy=8mm, dz=5mm

Reference Value = 108.7 V/m; Power Drift = -0.00 dB

Peak SAR (extrapolated) = 13.8 W/kg

**SAR(1 g) = 10.9 W/kg; SAR(10 g) = 8.42 W/kg**

Maximum value of SAR (measured) = 11.3 W/kg

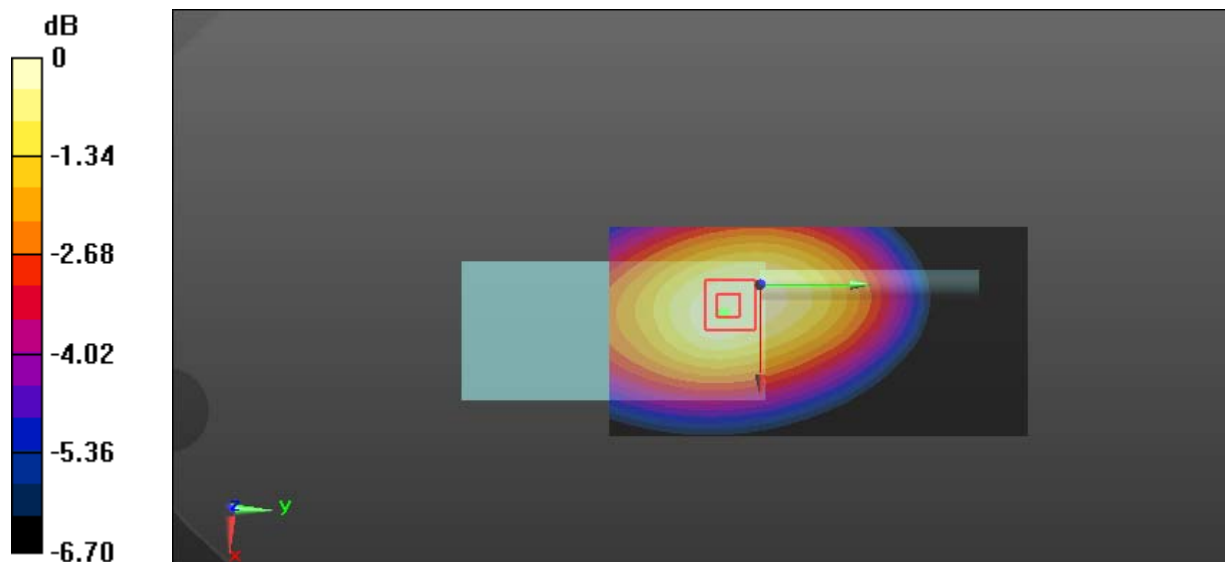

0 dB = 11.3 W/kg = 10.53 dBW/kg

**Test Plot 26#: PTT\_FM 25kHz\_Body Back\_452.4875 MHz****DUT: HP782 Uv; Type: Digital Portable Radio; Serial: 19052100220**

Communication System: FM; Frequency: 452.488 MHz; Duty Cycle: 1:1

Medium parameters used:  $f = 452.488$  MHz;  $\sigma = 0.939$  S/m;  $\epsilon_r = 57.039$ ;  $\rho = 1000$  kg/m<sup>3</sup>

Phantom section: Flat Section

DASY5 Configuration:

- Probe: ES3DV2 - SN3019; ConvF(7.1, 7.1, 7.1); Calibrated: 2018/8/20;
- Sensor-Surface: 4mm (Mechanical Surface Detection)
- Electronics: DAE3 Sn471; Calibrated: 2018/12/3
- Phantom: ELI v8.0; Type: QDOVA004AA; Serial: 2051
- Measurement SW: DASY52, Version 52.8 (8);

**Area Scan (61x121x1):** Interpolated grid: dx=1.500 mm, dy=1.500 mm

Maximum value of SAR (interpolated) = 10.3 W/kg

**Zoom Scan (5x5x7)/Cube 0:** Measurement grid: dx=8mm, dy=8mm, dz=5mm

Reference Value = 101.1 V/m; Power Drift = -0.03 dB

Peak SAR (extrapolated) = 12.3 W/kg

**SAR(1 g) = 9.8 W/kg; SAR(10 g) = 7.55 W/kg**

Maximum value of SAR (measured) = 10.2 W/kg

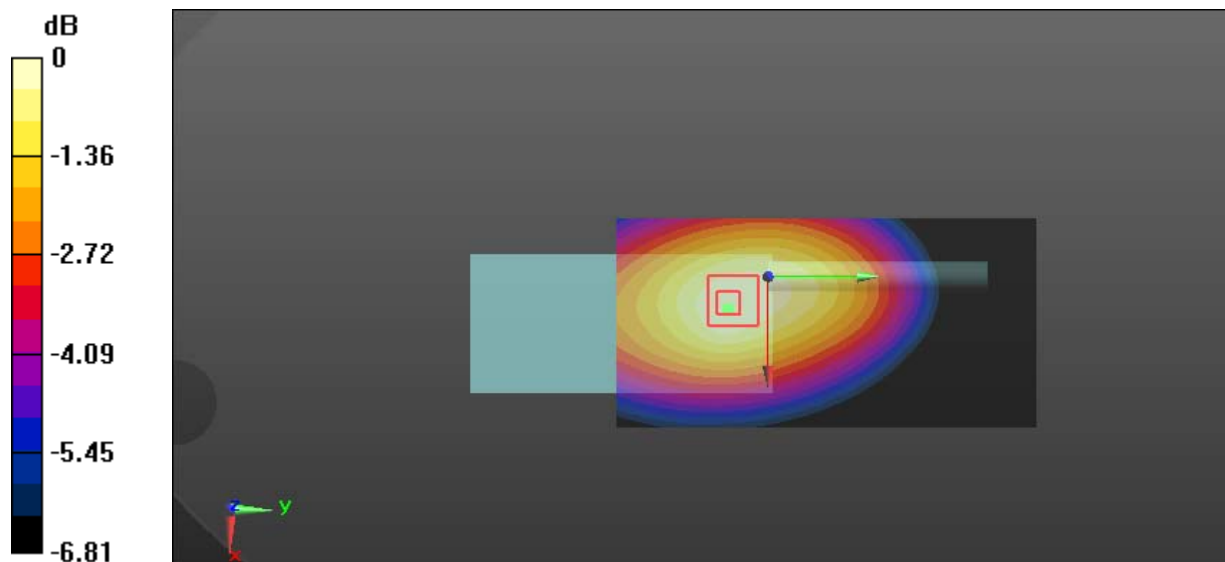

0 dB = 10.2 W/kg = 10.09 dBW/kg

**Test Plot 27#: PTT\_FM 25kHz\_Body Back\_469.9875 MHz****DUT: HP782 Uv; Type: Digital Portable Radio; Serial: 19052100220**

Communication System: FM; Frequency: 469.988 MHz; Duty Cycle: 1:1

Medium parameters used:  $f = 469.988$  MHz;  $\sigma = 0.945$  S/m;  $\epsilon_r = 56.825$ ;  $\rho = 1000$  kg/m<sup>3</sup>

Phantom section: Flat Section

DASY5 Configuration:

- Probe: ES3DV2 - SN3019; ConvF(7.1, 7.1, 7.1); Calibrated: 2018/8/20;
- Sensor-Surface: 4mm (Mechanical Surface Detection)
- Electronics: DAE3 Sn471; Calibrated: 2018/12/3
- Phantom: ELI v8.0; Type: QDOVA004AA; Serial: 2051
- Measurement SW: DASY52, Version 52.8 (8);

**Area Scan (61x121x1):** Interpolated grid: dx=1.500 mm, dy=1.500 mm

Maximum value of SAR (interpolated) = 7.99 W/kg

**Zoom Scan (5x5x7)/Cube 0:** Measurement grid: dx=8mm, dy=8mm, dz=5mm

Reference Value = 91.12 V/m; Power Drift = 0.06 dB

Peak SAR (extrapolated) = 10.1 W/kg

**SAR(1 g) = 7.91 W/kg; SAR(10 g) = 6.08 W/kg**

Maximum value of SAR (measured) = 8.30 W/kg

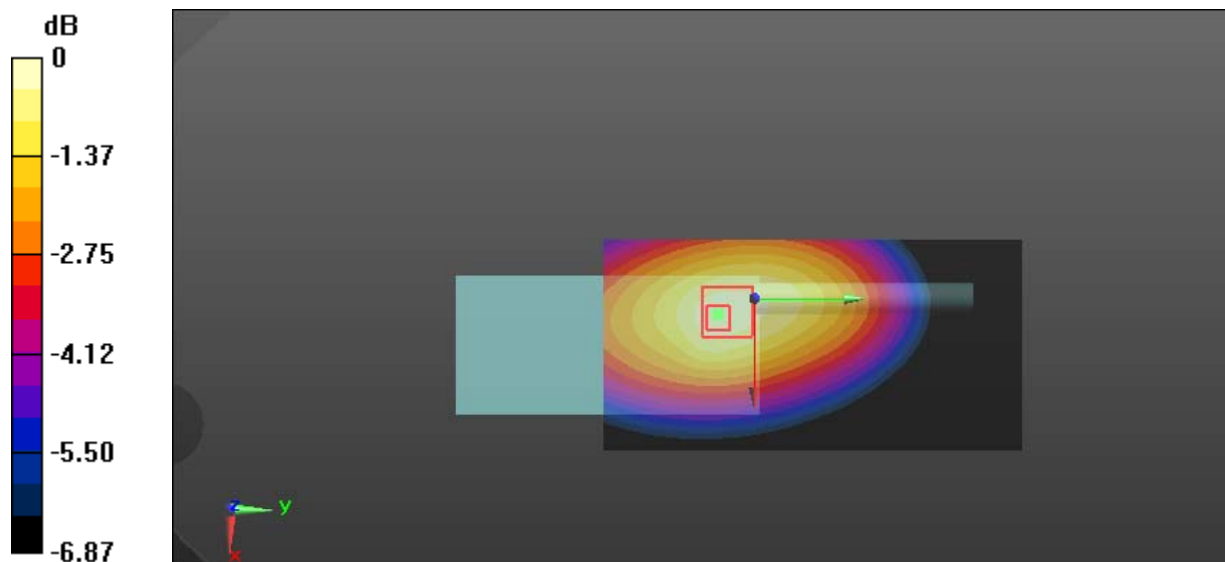

0 dB = 8.30 W/kg = 9.19 dBW/kg

**Test Plot 28#: PTT\_4FSK 12.5kHz\_Body Back\_435.0125 MHz****DUT: HP782 Uv; Type: Digital Portable Radio; Serial: 19052100220**

Communication System: 4FSK; Frequency: 435.012 MHz; Duty Cycle: 1:2

Medium parameters used:  $f = 435.012$  MHz;  $\sigma = 0.932$  S/m;  $\epsilon_r = 57.255$ ;  $\rho = 1000$  kg/m<sup>3</sup>

Phantom section: Flat Section

DASY5 Configuration:

- Probe: ES3DV2 - SN3019; ConvF(7.1, 7.1, 7.1); Calibrated: 2018/8/20;
- Sensor-Surface: 4mm (Mechanical Surface Detection)
- Electronics: DAE3 Sn471; Calibrated: 2018/12/3
- Phantom: ELI v8.0; Type: QDOVA004AA; Serial: 2051
- Measurement SW: DASY52, Version 52.8 (8);

**Area Scan (61x121x1):** Interpolated grid: dx=1.500 mm, dy=1.500 mm

Maximum value of SAR (interpolated) = 6.60 W/kg

**Zoom Scan (6x6x7)/Cube 0:** Measurement grid: dx=8mm, dy=8mm, dz=5mm

Reference Value = 80.04 V/m; Power Drift = -0.02 dB

Peak SAR (extrapolated) = 7.92 W/kg

**SAR(1 g) = 6.15 W/kg; SAR(10 g) = 4.73 W/kg**

Maximum value of SAR (measured) = 6.52 W/kg

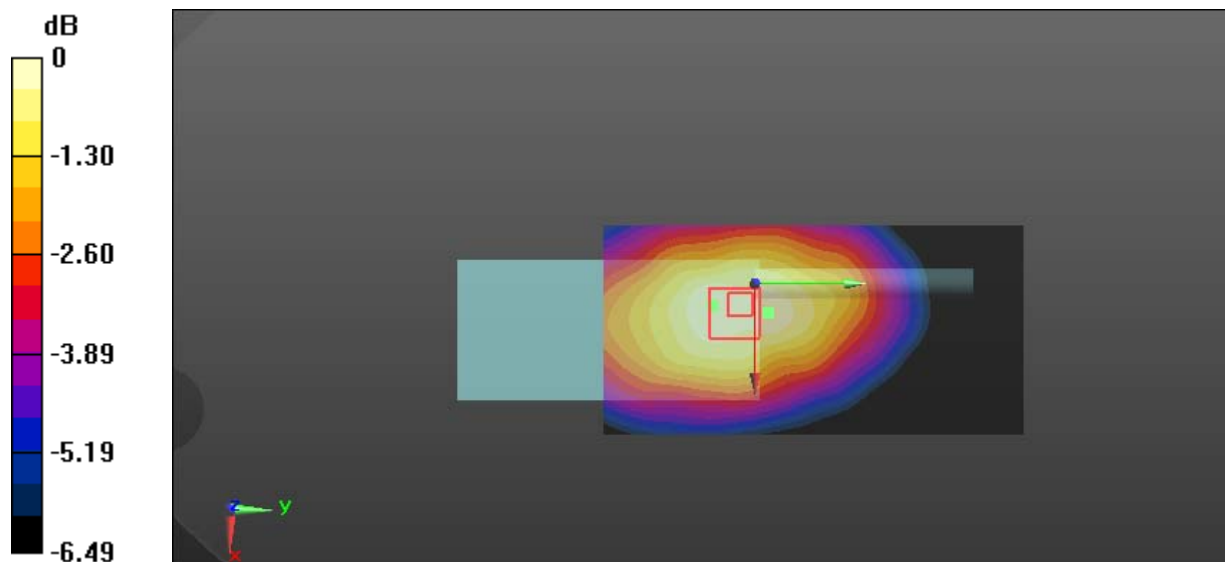

0 dB = 6.52 W/kg = 8.14 dBW/kg