



FCC PART 22, 74, 80 and 90

TEST REPORT

For

Hytera Communications Corporation Limited

Hytera Tower, Hi-Tech Industrial Park North, 9108# Beihuan Road, Nan shan District, Shenzhen,
518057 China

FCC ID: YAMHM78XVHFS

Report Type: Original Report	Product Type: DIGITAL MOBILE RADIO
Report Number: <u>DG2210702-26804E-00C</u>	
Report Date: <u>2021-07-30</u>	
Reviewed By: Gavin Xu RF Engineer	
Prepared By:	Bay Area Compliance Laboratories Corp. (Dongguan) No.12, Pulong East 1 st Road, Tangxia Town, Dongguan, Guangdong, China Tel: +86-769-86858888 Fax: +86-769-86858891 www.baclcorp.com.cn

TABLE OF CONTENTS

GENERAL INFORMATION	3
PRODUCT DESCRIPTION FOR EQUIPMENT UNDER TEST (EUT)	3
TECHNICAL SPECIFICATION	3
OBJECTIVE	3
RELATED SUBMITTAL(S)/GRANT(S)	3
TEST METHODOLOGY	3
MEASUREMENT UNCERTAINTY	4
TEST FACILITY	4
DECLARATIONS	4
SYSTEM TEST CONFIGURATION	5
DESCRIPTION OF TEST CONFIGURATION.....	5
EQUIPMENT MODIFICATIONS.....	5
EUT EXERCISE SOFTWARE	5
SUPPORT CABLE LIST AND DETAILS.....	5
BLOCK DIAGRAM OF TEST SETUP	5
TEST EQUIPMENT LIST	6
ENVIRONMENTAL CONDITIONS	6
SUMMARY OF TEST RESULTS	7
2 - RF OUTPUT POWER	8
APPLICABLE STANDARD.....	8
TEST PROCEDURE.....	8
TEST DATA.....	8
3 - MODULATION CHARACTERISTIC	14
APPLICABLE STANDARD.....	14
TEST PROCEDURE.....	14
TEST DATA.....	14
4 – OCCUPIED BANDWIDTH & EMISSION MASK.....	19
APPLICABLE STANDARD.....	19
TEST PROCEDURE.....	19
TEST DATA.....	19
5 - SPURIOUS EMISSIONS AT ANTENNA TERMINALS.....	29
APPLICABLE STANDARD.....	29
TEST PROCEDURE.....	29
TEST DATA.....	29
6 - RADIATED SPURIOUS EMISSIONS.....	34
APPLICABLE STANDARD.....	34
TEST PROCEDURE.....	34
TEST DATA.....	34
7 - FREQUENCY STABILITY	43
APPLICABLE STANDARD.....	43
TEST PROCEDURE.....	43
TEST DATA.....	43
8 - TRANSIENT FREQUENCY BEHAVIOR	47
APPLICABLE STANDARD.....	47
TEST PROCEDURE.....	47
TEST DATA.....	48

GENERAL INFORMATION

Product Description for Equipment under Test (EUT)

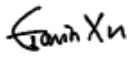
EUT Name:	DIGITAL MOBILE RADIO
EUT Model:	HM782 VHF
Multiple Models:	HM785 VHF, HM786 VHF, HM788 VHF HDM782 VHF, HDM785 VHF, HDM786 VHF, HDM788 VHF
Model Difference:	Refer to the DOS letter
Rated Input Voltage:	DC 13.6V
Serial Number:	DG2210702-26804E-RF-S1
EUT Received Date:	2021.07.03
EUT Received Status:	Good

Technical Specification

Operation Frequency Range (MHz):	136-174
Rated RF Output Power (Conducted) (W):	High power level: 50 Low power level: 5
Modulation Type:	FM, 4FSK
Channel Spacing (kHz):	12.5/25

Objective

This test report is prepared on behalf of *Hytera Communications Corporation Limited* in accordance with Part 2, and Part 22,74,80 and 90 of the Federal Communication Commissions rules.

Related Submittal(s)/Grant(s)

FCC Part 15C DSS submissions with FCC ID: YAMHM78XVHFS
FCC Part 15C DTS submissions with FCC ID: YAMHM78XVHFS

Test Methodology

All tests and measurements indicated in this document were performed in accordance with:

the Code of federal Regulations Title 47, Part 2, Part 22, Part 74, Part 80 and Part 90

ANSI C63.26-2015, American National Standard for Compliance Testing of Transmitters Used in Licensed Radio Services

TIA-603-E-2016, Land Mobile FM or PM Communications Equipment Measurement and Performance Standards

All emissions measurement was performed at Bay Area Compliance Laboratories Corp. (Dongguan). The radiated testing was performed at an antenna-to-EUT distance of 3 meters.

Measurement Uncertainty

Parameter	Measurement Uncertainty
Occupied Channel Bandwidth	±5 %
RF output power, conducted	±0.61dB
Unwanted Emissions, radiated	30MHz ~ 1GHz: 5.85 dB 1G~26.5GHz: 5.23 dB
Unwanted Emissions, conducted	±1.5 dB
Temperature	±1°C
Humidity	±5%
DC and low frequency voltages	±0.4%
Duty Cycle	1%

Note: Otherwise required by the applicant or Product Regulations, Decision Rule in this report did not consider the uncertainty. The extended uncertainty given in this report is obtained by combining the standard uncertainty times the coverage factor K with the 95% confidence interval.

Test Facility

The Test site used by Bay Area Compliance Laboratories Corp. (Dongguan) to collect test data is located on the No.12, Pulong East 1st Road, Tangxia Town, Dongguan, Guangdong, China.

The lab has been recognized as the FCC accredited lab under the KDB 974614 D01 and is listed in the FCC Public Access Link (PAL) database, FCC Registration No. : 897218, the FCC Designation No. : CN1220.

The lab has been recognized by Innovation, Science and Economic Development Canada to test to Canadian radio equipment requirements, the CAB identifier: CN0022.

Declarations

BACL is not responsible for the authenticity of any test data provided by the applicant. Data included from the applicant that may affect test results are marked with a triangle symbol “▲”. Customer model name, addresses, names, trademarks etc. are not considered data.

Unless otherwise stated the results shown in this test report refer only to the sample(s) tested.

This report cannot be reproduced except in full, without prior written approval of the Company.

This report is valid only with a valid digital signature. The digital signature may be available only under the Adobe software above version 7.0.

This report may contain data that are not covered by the accreditation scope and shall be marked with an asterisk “★”.

SYSTEM TEST CONFIGURATION

Description of Test Configuration

The system was configured for testing in a test mode which has been done in the factory.

Equipment Modifications

No modification was made to the EUT.

EUT Exercise Software

No software was tested in test.

Local Support Equipment List and Details

Manufacturer	Description	Model	Serial Number
Proinstrument	DC Power Supply	pps3300	3300012
DELL	Laptop	E6410	CB30920865
BEW	Coaxial Termination	TF300-6-B	/

Support Cable List and Details

Cable Description	Shielding Type	Ferrite Core	Length(m)	From	To
DC Line	No	No	3	DC Power Supply	EUT
Coaxial Cable	Yes	No	0.5	EUT	Termination
GPS Antenna Cable	Yes	No	3	EUT	GPS Antenna
Network Cable	No	Yes	10	EUT	Laptop
MIC Cable	No	No	1	EUT	MIC

Block Diagram of Test Setup

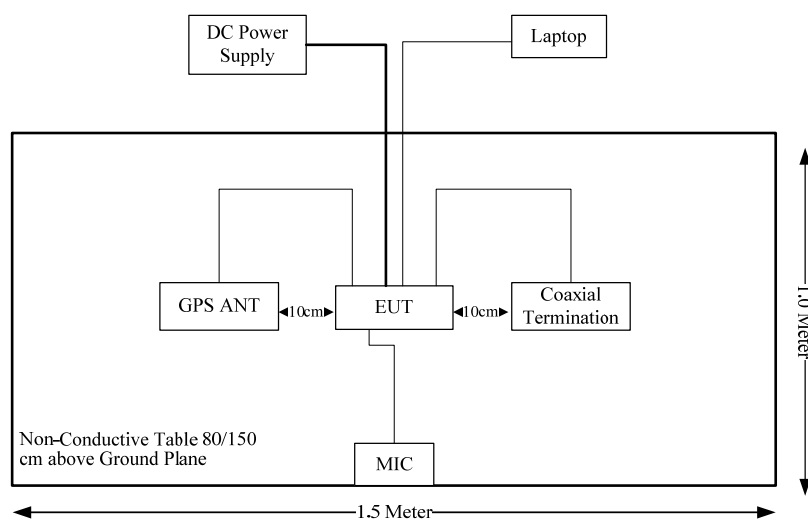

Test Equipment List

Manufacturer	Description	Model	Serial Number	Calibration Date	Calibration Due Date
Radiated emissions below 1GHz					
Sunol Sciences	Antenna	JB3	A060611-2	2020-08-25	2023-08-25
R&S	EMI Test Receiver	ESCI	100224	2020-09-12	2021-09-12
Unknown	Coaxial Cable	C-NJNJ-50	C-1000-01	2020-09-05	2021-09-05
Unknown	Coaxial Cable	C-NJNJ-50	C-0400-02	2020-09-05	2021-09-05
Unknown	Coaxial Cable	C-NJNJ-50	C-0530-01	2020-09-24	2021-09-24
Sonoma	Amplifier	310N	185914	2020-10-13	2021-10-13
EMCO	Adjustable Dipole Antenna	3121C	9109-753	N/A	N/A
Unknown	Coaxial Cable	C-NJNJ-50	C-0200-02	2020-09-05	2021-09-05
Agilent	Signal Generator	E8247C	MY43321350	2021-04-25	2022-04-24
Mini-Circuits	High Pass Filter	BHP-300+	15542	2020-09-05	2021-09-05
Radiated emissions above 1GHz					
ETS-Lindgren	Horn Antenna	3115	000 527 35	2018-10-12	2021-10-12
Agilent	Spectrum Analyzer	E4440A	SG43360054	2021-07-07	2022-07-07
Unknown	Coaxial Cable	C-SJSJ-50	C-0800-01	2020-09-05	2021-09-05
Mini-Circuit	Amplifier	ZVA-213-S+	54201245	2020-09-05	2021-09-05
TDK RF	Horn Antenna	HRN-0118	130 084	2018-10-12	2021-10-12
Unknown	Coaxial Cable	C-NJNJ-50	C-0200-02	2020-09-05	2021-09-05
Agilent	Signal Generator	E8247C	MY43321350	2020-12-09	2021-12-08
Mini-Circuits	High Pass Filter	BHP-300+	15542	2020-09-05	2021-09-05
RF Conducted Test					
R&S	Spectrum Analyzer	FSV40	101474	2021-07-06	2022-07-05
Rohde & Schwarz	Signal Analyzer	FSIQ26	831929/005	2020-09-12	2021-09-12
yzjingcheng	Coaxial Cable	KTRFBU-141-50	41010013	2020-09-05	2021-09-05
yzjingcheng	Coaxial Cable	KTRFBU-141-50	41005012	2020-09-05	2021-09-05
E-Microwave	Blocking Control	EMDCB-00036	0E01201047	2021-05-06	2022-05-06
Weinschel	Coaxial Attenuators	53-20-34	LN749	2020-09-06	2021-09-06
E-Microwave	Coaxial Attenuators	EMCA40-200SN-6	OE01201046	2020-09-06	2021-09-06
HP	RF Communications Test Set	8920A	3438A05201	2021-07-07	2022-07-07
BACL	TEMP&HUMI Test Chamber	BTH-150	30022	2021-02-24	2022-02-23
UNI-T	Multimeter	UT39A	M130199938	2021-07-01	2022-07-01
Pro instrument	DC Power Supply	pps3300	3300012	N/A	N/A
Mini-Circuits	High Pass Filter	BHP-300+	15542	2020-09-05	2021-09-05

* **Statement of Traceability:** Bay Area Compliance Laboratories Corp. (Dongguan) attests that all calibrations have been performed, traceable to National Primary Standards and International System of Units (SI).

Environmental Conditions

Test Item:	RF Conducted	Radiation Below 1GHz	Radiation Above 1GHz
Temperature:	26.2~27.2°C	26.6 °C	29.4 °C
Relative Humidity:	47~56 %	54%	29 %
ATM Pressure:	100.3~101.1 kPa	100.5kPa	100.5kPa
Tester:	Levi Shi	Burt Hu	Jeremy Liang
Test Date:	2021.07.08~2021.07.29	2021.07.14	2021.07.14

SUMMARY OF TEST RESULTS

S/N	FCC Rules	Description of Test	Results
2	§2.1046; § 22.727; §80.215; §74.461; §90.205	RF Output Power	Compliance
3	§2.1047	Modulation Characteristic	Compliance
4	§2.1049;§22.357;§ 22.731; §74.462;§80.205; §80.207 §90.209; §90.210	Occupied Bandwidth & Emission Mask	Compliance
5	§2.1051; §22.359; §74.462; §80.211;§90.210	Spurious Emission at Antenna Terminal	Compliance
6	§2.1053;§22.861; §74.462;§80.211;§90.210	Spurious Radiated Emissions	Compliance
7	§2.1055; § 22.355; §74.464; §80.209; §90.213	Frequency Stability	Compliance
8	§90.214	Transient Frequency Behavior	Compliance

2 - RF OUTPUT POWER

Applicable Standard

FCC §2.1046, § 22.727, §74.461, §80.215 and §90.205

Test Procedure

Conducted RF Output Power:

The RF output of the transmitter was connected to the input of the spectrum analyzer through sufficient attenuation.

Spectrum Analyzer Setting:

R B/W Video B/W
 100 kHz 300 kHz

Test Data

Test Mode: Transmitting

Test Result: Compliance. *Please refer to following table and plots.*

Channel Separation	Test Modulation	Test Channel	Test Frequency (MHz)	Conducted Output Power (dBm)		Limit (dBm)		Note
				High Power Level	Low Power Level	High Power Level	Low Power Level	
12.5kHz	FM	Low	136.0125	47.40	37.22	47.78	37.78	FCC
		Middle	155.7525	47.33	37.38	47.78	37.78	Part 90
		High	173.9875	47.45	37.24	47.78	37.78	FCC
		Additional	150.8125	47.33	36.55	47.78	37.78	Part 22
		Additional	161.1000	47.31	37.33	47.78	37.78	Part 74
	4FSK	Low	136.0125	47.38	37.17	47.78	37.78	FCC
		Middle	155.7525	47.32	37.33	47.78	37.78	Part 90
		High	173.9875	47.44	37.18	47.78	37.78	FCC
25kHz	FM	Additional	150.8125	47.33	36.51	47.78	37.78	Part 22
		Additional	154.0125	47.32	37.07	47.78	37.78	Part 80
		Additional	161.1000	47.31	37.31	47.78	37.78	Part 74

Note:

The high rated power level is 50W(47dBm), and low rated power level is 5W(37dBm).

The output power shall not exceed by more than 20 percent the manufacturer's rated output power for the particular transmitter specifically listed on the authorization.

FM, 12.5kHz:

Low Channel, 136.0125 MHz High Power

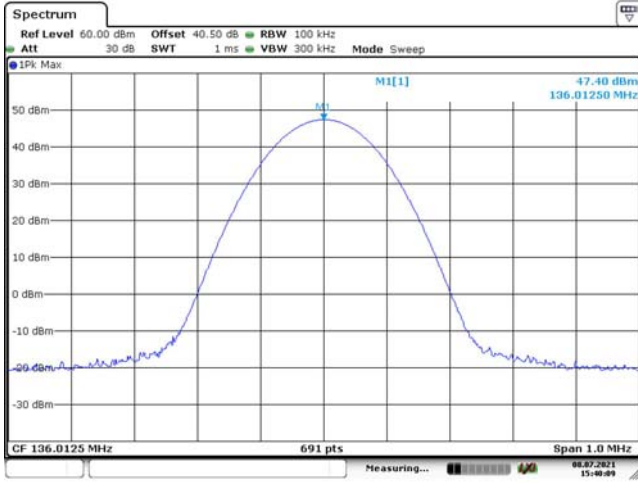

Low Channel, 136.0125 MHz Low Power



Part 90, Middle Channel, 155.7525 MHz High Power

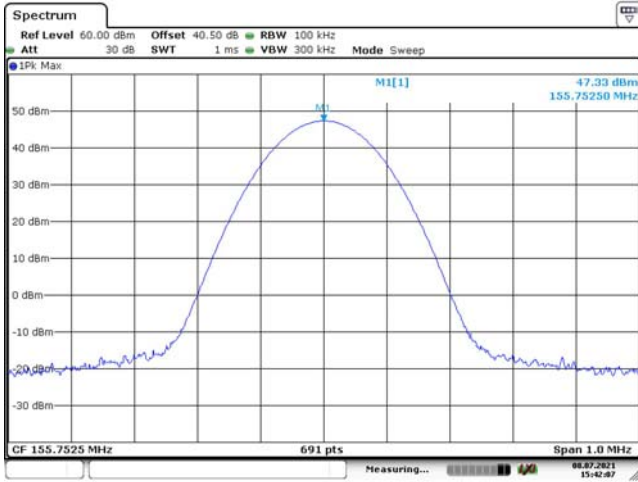

Part 90, Middle Channel, 155.7525 MHz Low Power

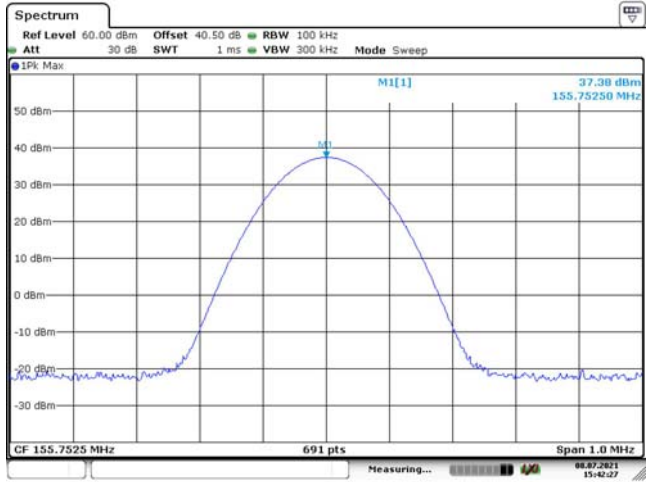

High Channel, 173.9875 MHz High Power

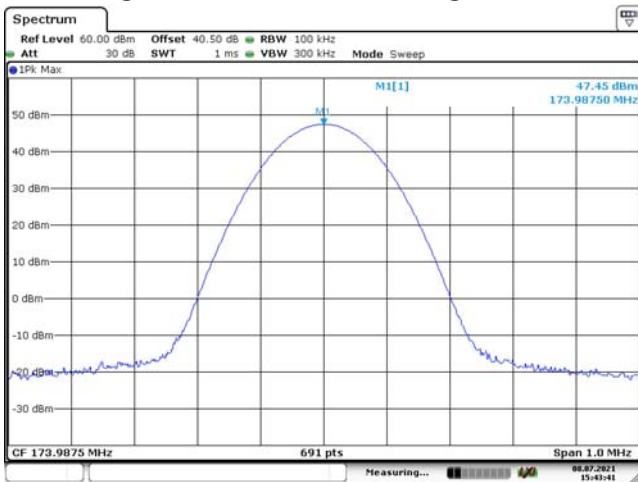

High Channel, 173.9875 MHz Low Power

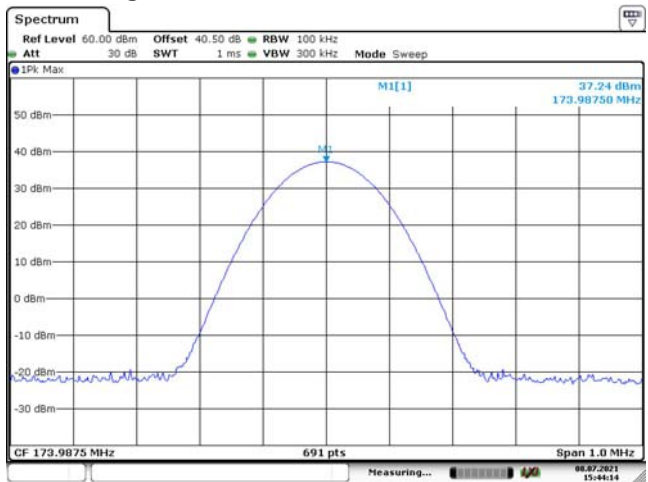

Part 22, Additional Channel, 150.8125 MHz High Power

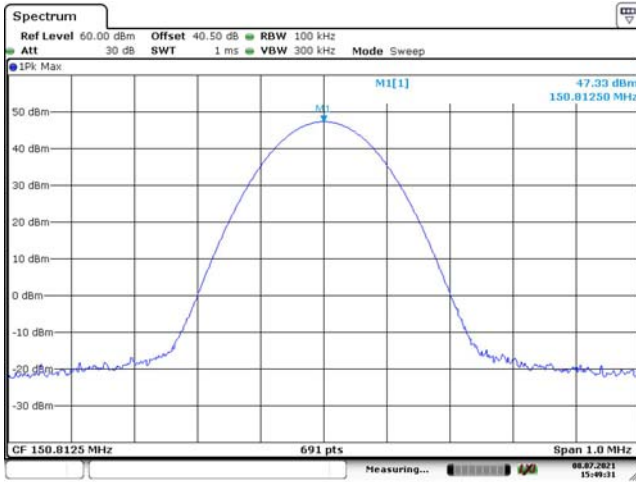

Date: 8_JUL_2021 15:49:32

Part 22, Additional Channel, 150.8125 MHz Low Power

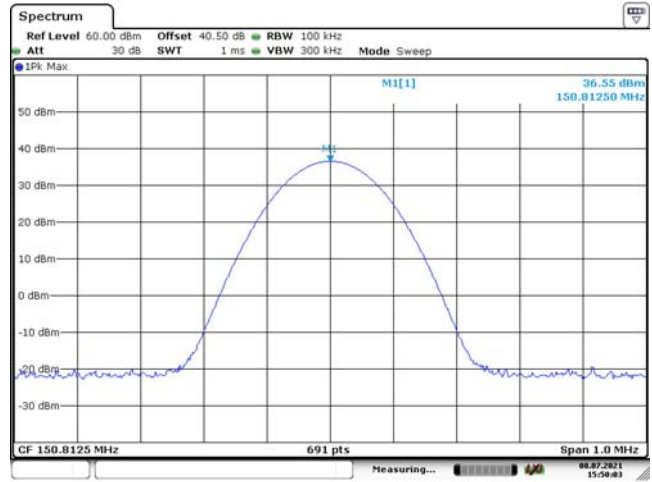

Date: 8_JUL_2021 15:50:04

Part 74, Additional Channel, 161.1 MHz High Power

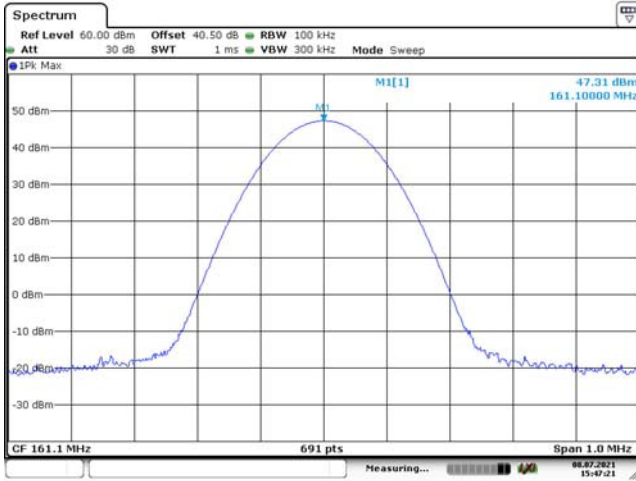

Date: 8_JUL_2021 15:47:22

Part 74, Additional Channel, 161.1 MHz Low Power

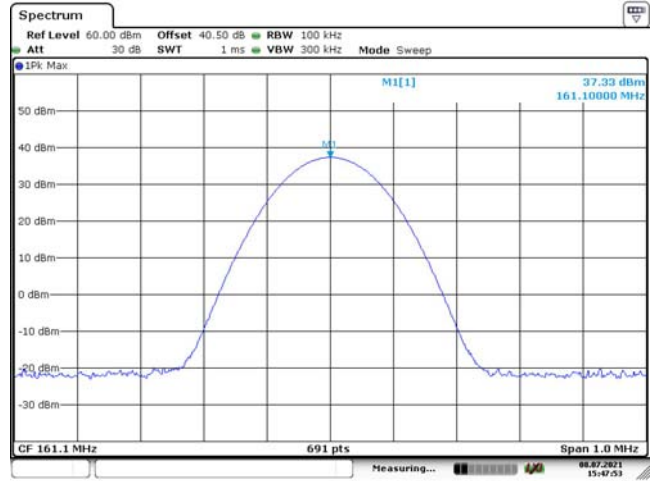

Date: 8_JUL_2021 15:47:54

4FSK, 12.5kHz:

Low Channel, 136.0125 MHz High Power

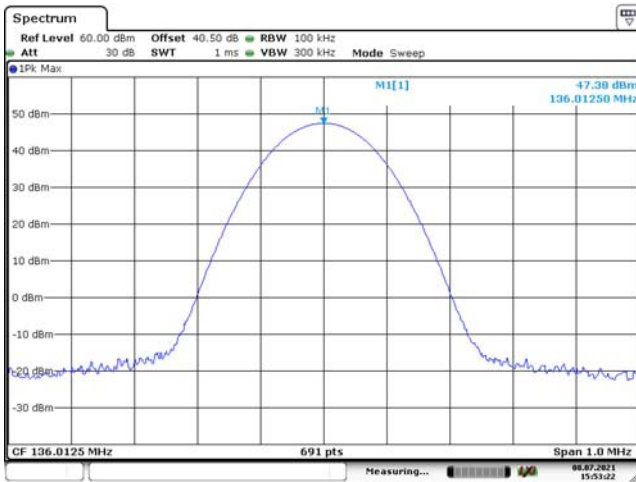

Date: 8_JUL_2021 15:53:23

Low Channel, 136.0125 MHz Low Power

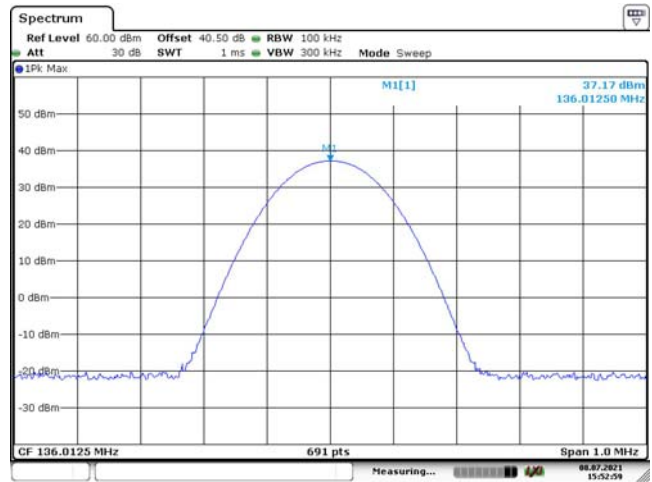

Date: 8_JUL_2021 15:53:00

Part 90, Middle Channel, 155.7525 MHz High Power

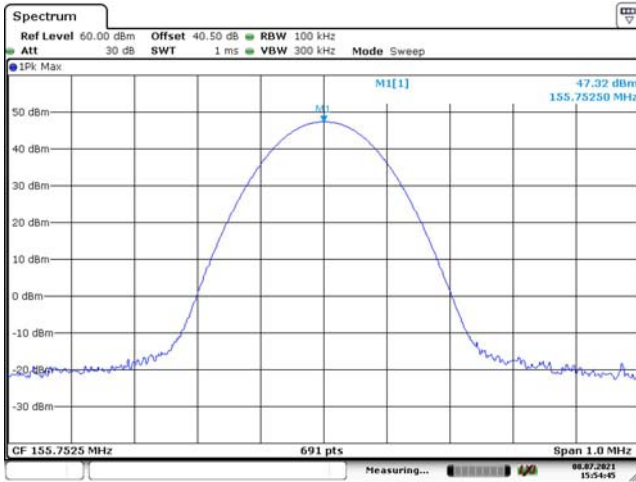

Date: 8.JUL.2021 15:54:46

Part 90, Middle Channel, 155.7525 MHz Low Power

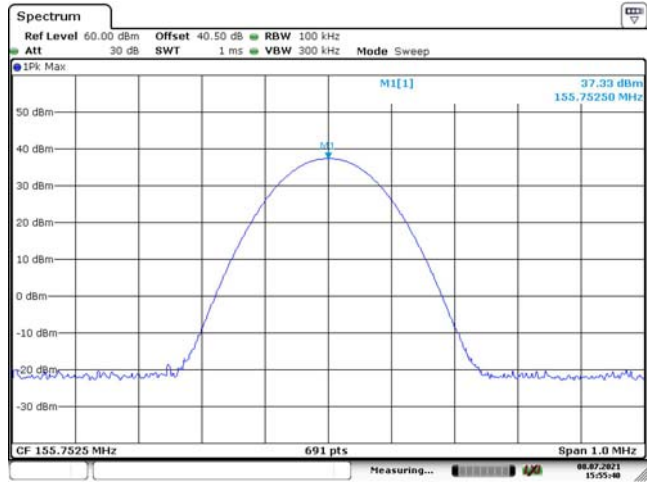

Date: 8.JUL.2021 15:55:41

High Channel, 173.9875 MHz High Power

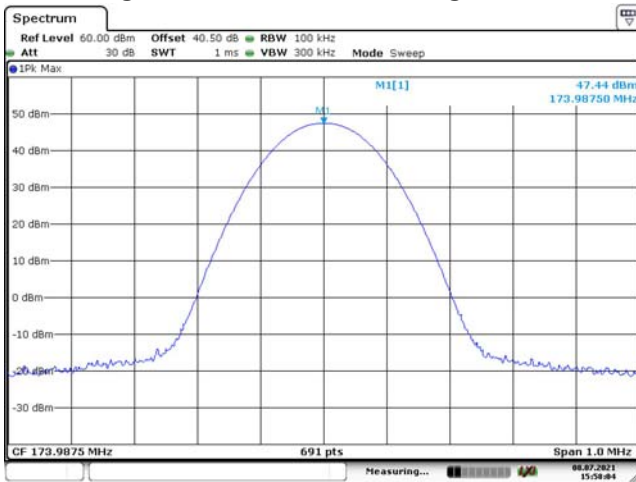

Date: 8.JUL.2021 15:58:04

High Channel, 173.9875 MHz Low Power

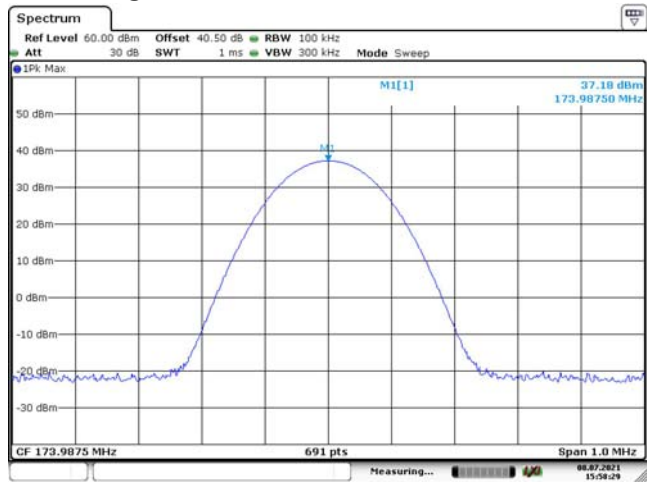

Date: 8.JUL.2021 15:58:29

Part 22, Additional Channel, 150.8125 MHz High Power

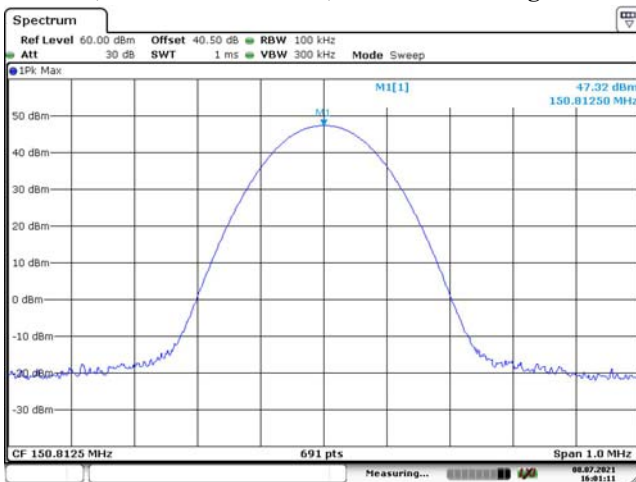

Date: 8.JUL.2021 16:01:11

Part 22, Additional Channel, 150.8125 MHz Low Power

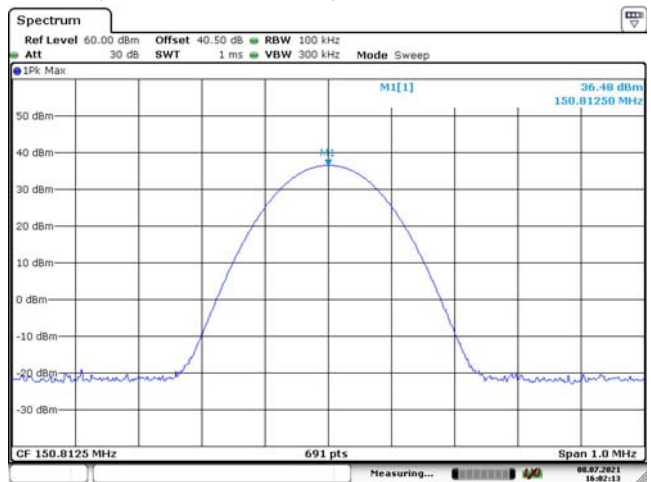

Date: 8.JUL.2021 16:02:13

Part 74, Additional Channel, 161.1 MHz High Power

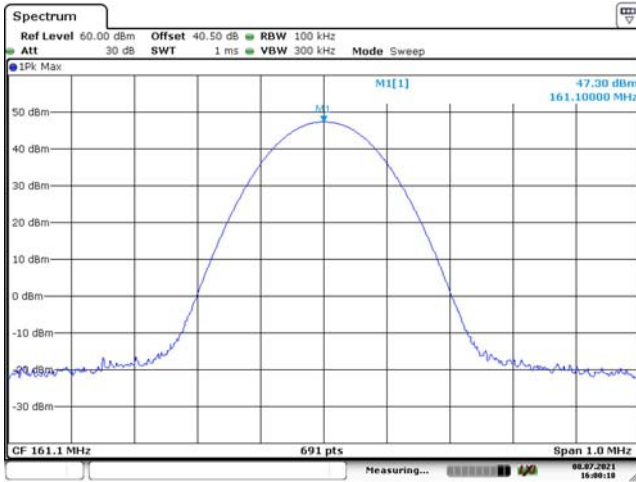

Part 74, Additional Channel, 161.1 MHz Low Power

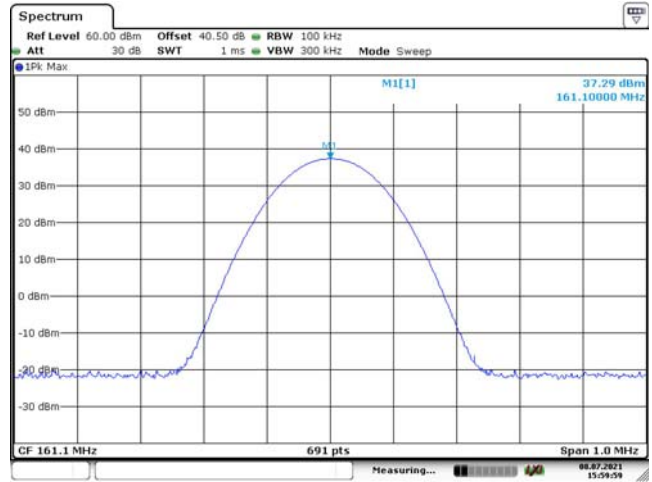

FM, 25kHz:

Part 22, Additional Channel, 150.8125 MHz High Power

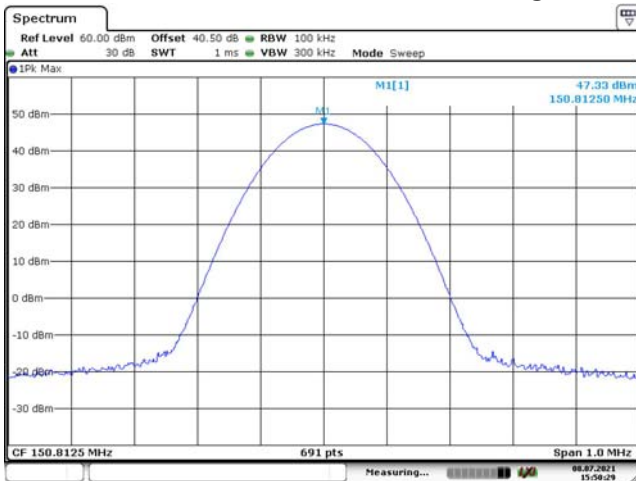

Part 22, Additional Channel, 150.8125 MHz Low Power

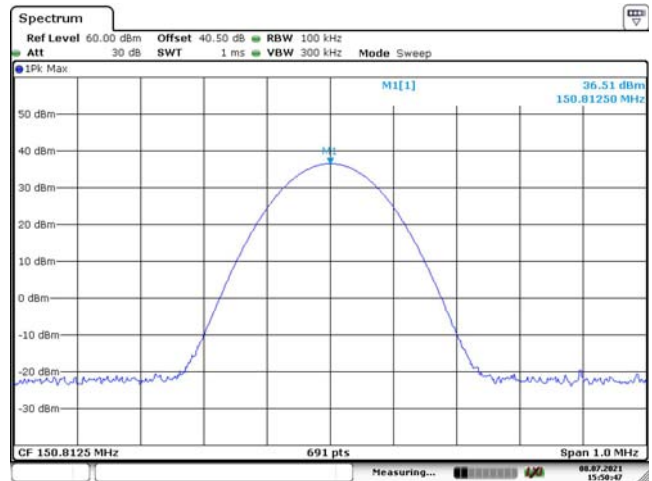

Part 80, Additional Channel, 154.0125 MHz High Power

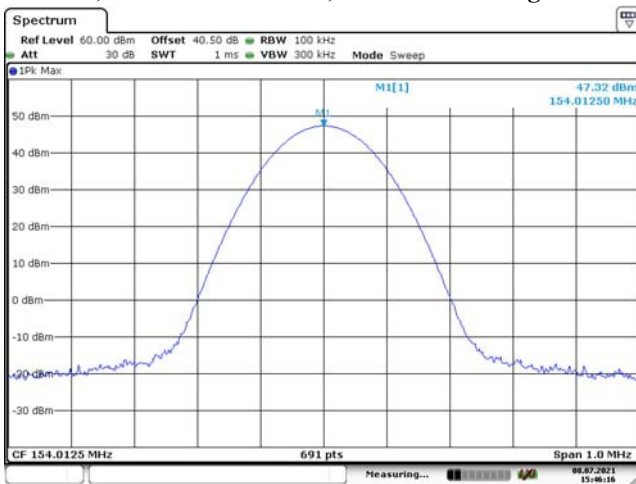

Part 80, Additional Channel, 154.0125 MHz Low Power



Part 74, Additional Channel, 161.1 MHz High Power

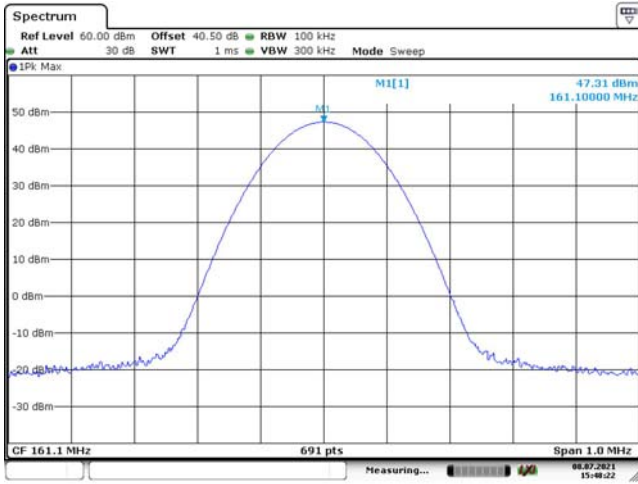

Date: 8.JUL.2021 15:48:23

Part 74, Additional Channel, 161.1 MHz Low Power

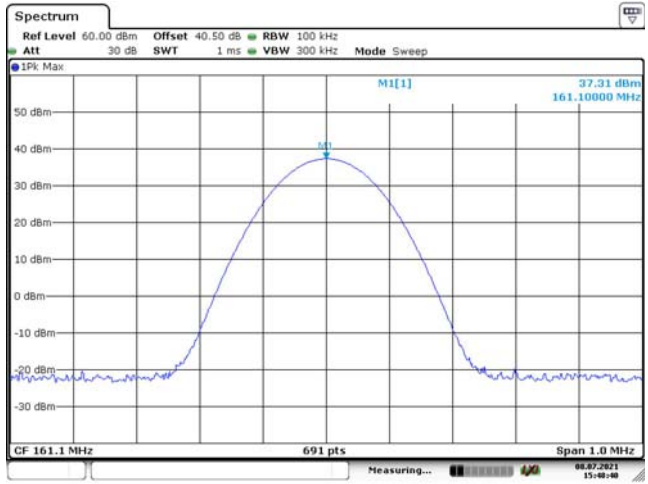

Date: 8.JUL.2021 15:48:41

3 - MODULATION CHARACTERISTIC

Applicable Standard

FCC §2.1047

- (a) Equipment which utilizes voice modulated communication shall show the frequency response of the audio modulating circuit over a range of 100 to 5000 Hz. for equipment which is required to have a low pass filter, the frequency response of the filter, or all of the circuitry installed between the modulation limited and the modulated stage shall be supplied.
- (b) Equipment which employs modulation limiting, a curve showing the percentage of modulation versus the modulation input voltage shall be supplied.

Test Procedure

Test Method: TIA-603-E 2.2.3

Test Data

Test Mode: Transmitting

Test Result: Compliance.

Please refer to the following tables and plots.

Audio Frequency Response – High Power

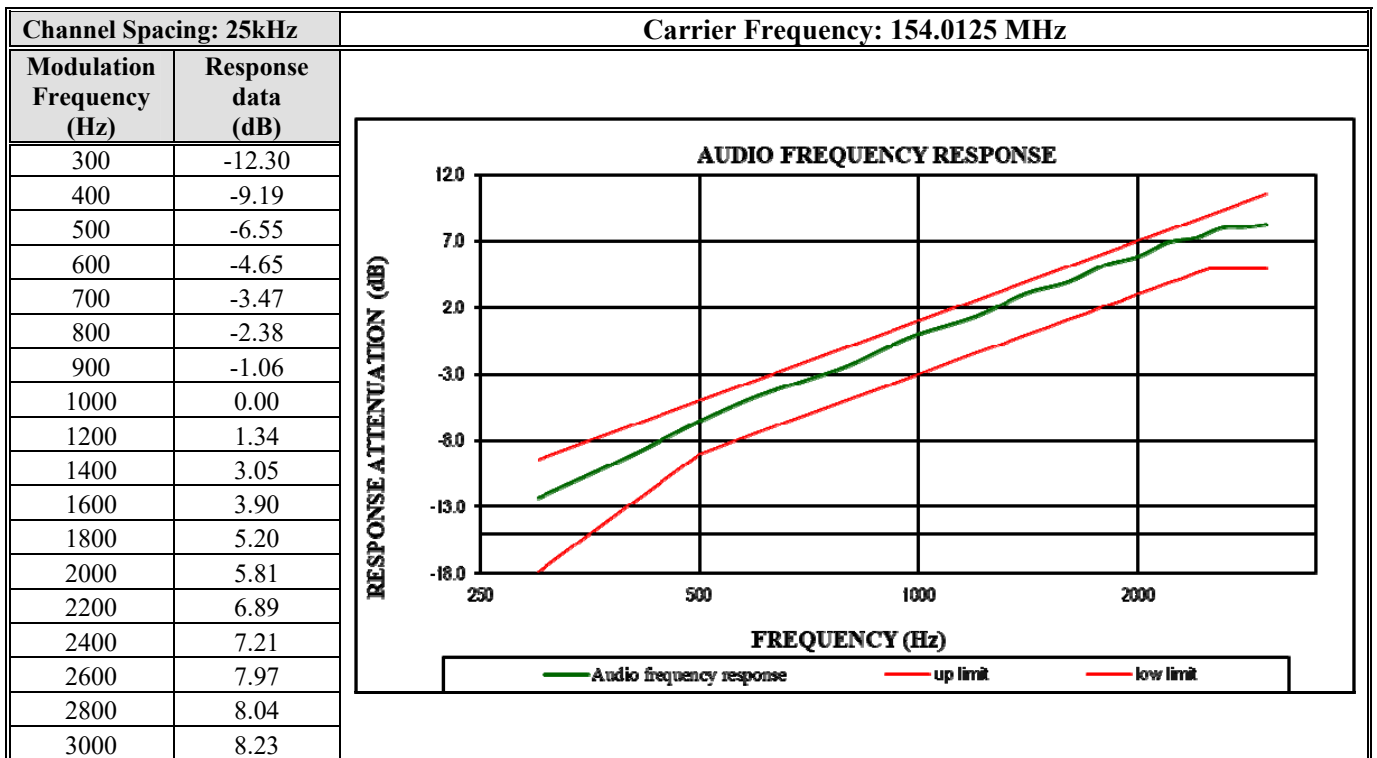
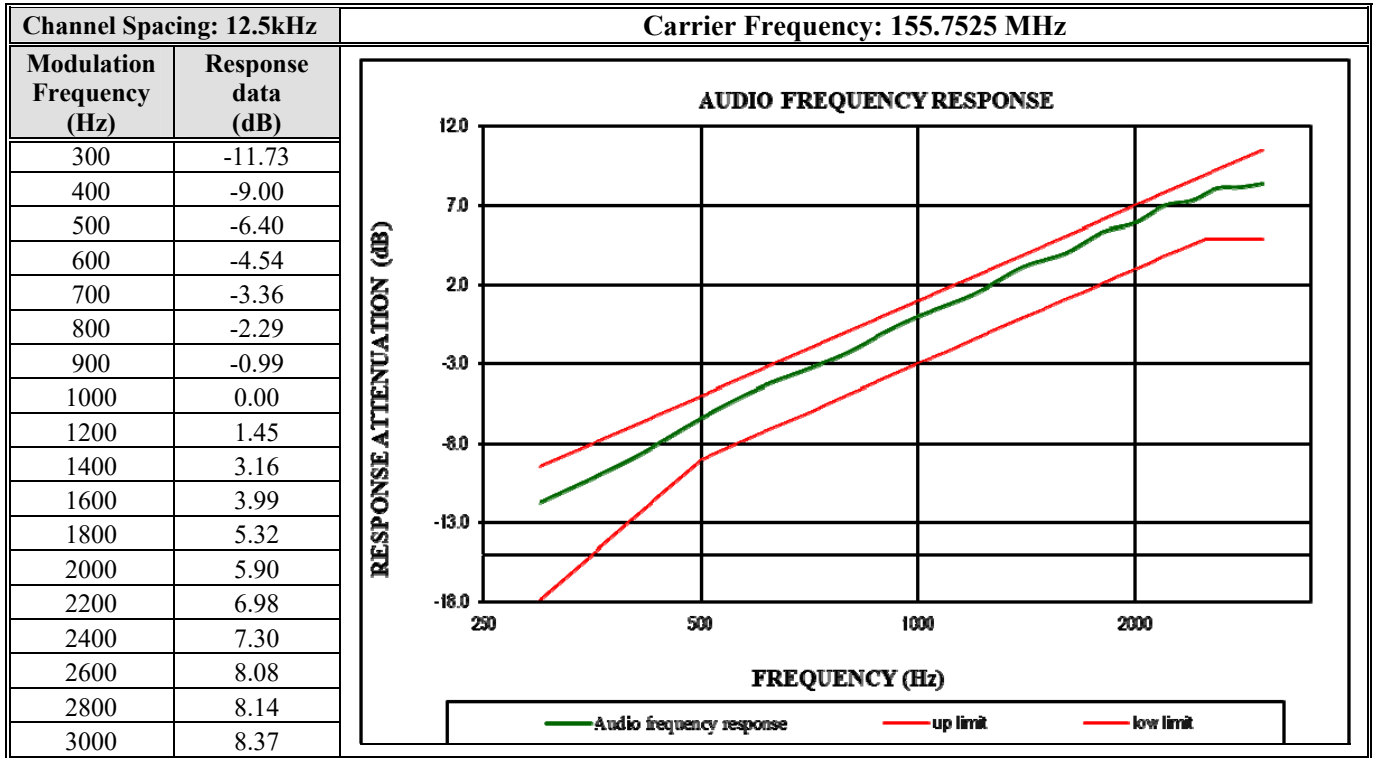

Modulation Limiting – High Power

Channel Spacing: 12.5kHz		Carrier Frequency: 155.7525 MHz			
Audio Frequency (Hz)	Instantaneous		Steady-state		Limit [kHz]
	Deviation (@+20dB) [kHz]	Deviation (@-20dB) [kHz]	Deviation (@+20dB) [kHz]	Deviation (@-20dB) [kHz]	
300	1.014	0.076	1.011	0.068	2.5
400	1.418	0.086	1.412	0.085	2.5
500	1.880	0.103	1.876	0.102	2.5
600	2.270	0.122	2.256	0.121	2.5
700	2.320	0.183	2.314	0.182	2.5
800	2.340	0.212	2.325	0.206	2.5
900	2.220	0.231	2.215	0.226	2.5
1000	2.120	0.203	2.116	0.201	2.5
1200	2.420	0.225	2.384	0.221	2.5
1400	2.380	0.236	2.374	0.234	2.5
1600	2.330	0.274	2.326	0.269	2.5
1800	2.350	0.314	2.348	0.306	2.5
2000	2.380	0.355	2.367	0.345	2.5
2200	2.270	0.365	2.257	0.358	2.5
2400	2.210	0.389	2.204	0.378	2.5
2600	2.070	0.412	2.067	0.406	2.5
2800	1.860	0.375	1.854	0.365	2.5
3000	1.580	0.331	1.556	0.328	2.5

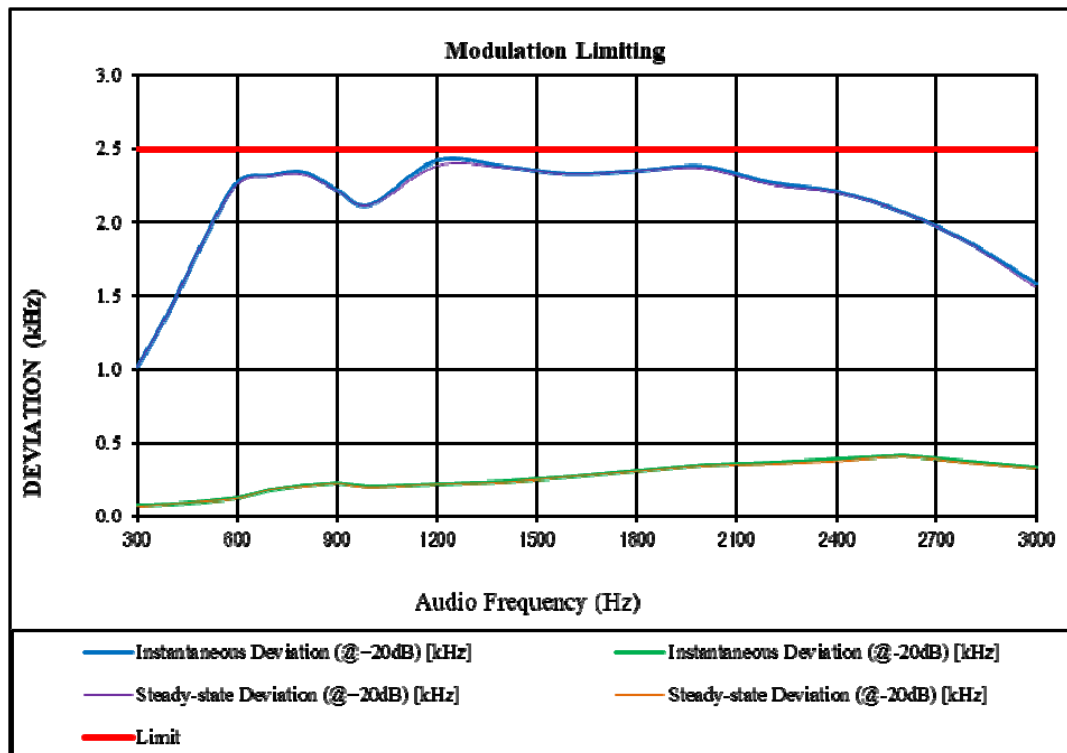

Channel Spacing: 25kHz		Carrier Frequency: 154.0125 MHz			
Audio Frequency (Hz)	Instantaneous		Steady-state		Limit [kHz]
	Deviation (@+20dB) [kHz]	Deviation (@-20dB) [kHz]	Deviation (@+20dB) [kHz]	Deviation (@-20dB) [kHz]	
300	2.013	0.121	2.010	0.118	5
400	2.753	0.208	2.754	0.201	5
500	3.750	0.175	3.745	0.168	5
600	4.460	0.225	4.458	0.216	5
700	4.530	0.275	4.524	0.268	5
800	4.550	0.312	4.541	0.309	5
900	4.290	0.294	4.250	0.286	5
1000	4.130	0.362	4.158	0.357	5
1200	4.660	0.417	4.652	0.408	5
1400	4.700	0.427	4.685	0.426	5
1600	4.430	0.519	4.425	0.506	5
1800	4.610	0.623	4.608	0.621	5
2000	4.663	0.628	4.669	0.624	5
2200	4.450	0.674	4.425	0.668	5
2400	4.330	0.657	4.315	0.652	5
2600	4.022	0.690	4.021	0.683	5
2800	3.620	0.649	3.618	0.645	5
3000	3.020	0.592	3.012	0.586	5

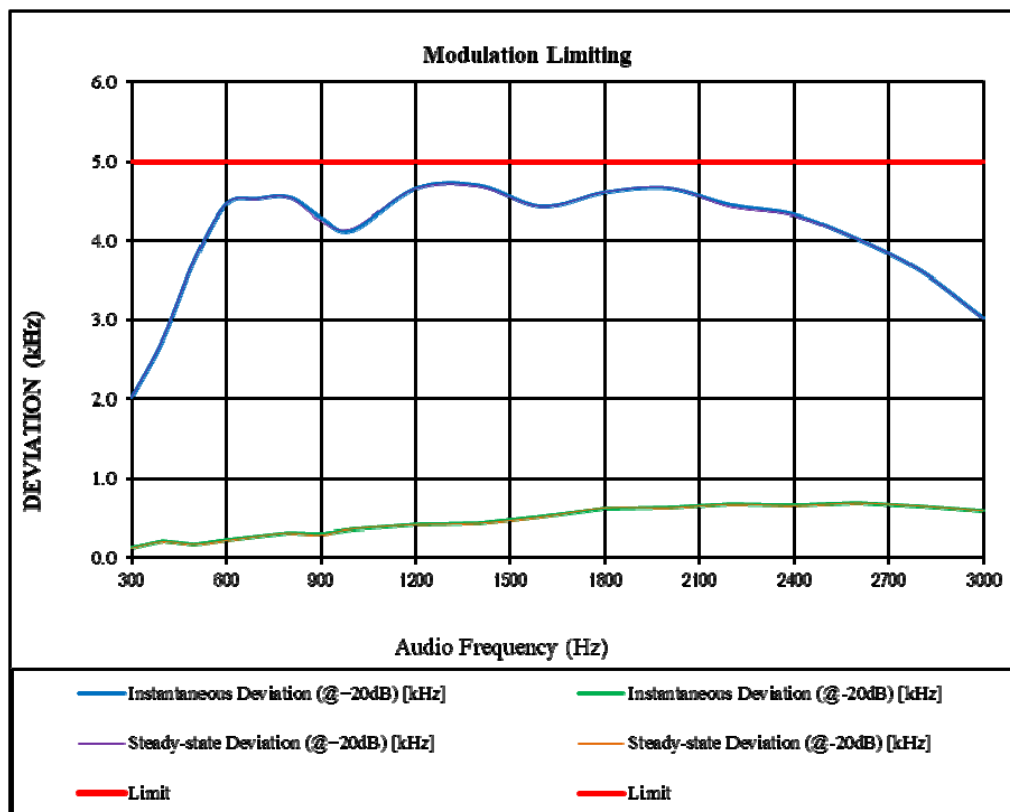

Audio Frequency Low Pass Filter Response – High Power

Channel Spacing: 12.5kHz		
Carrier Frequency: 155.7525 MHz		
Audio Frequency (kHz)	Response Attenuation (dB)	Limit (dB)
3.0	-5.8	0.0
3.5	-13.1	-6.7
4.0	-18.5	-12.5
5.0	-27.9	-22.2
7.0	-43.5	-36.8
10.0	-60.1	-52.3
15.0	-75.8	-69.9
20.0	-87.4	-82.5

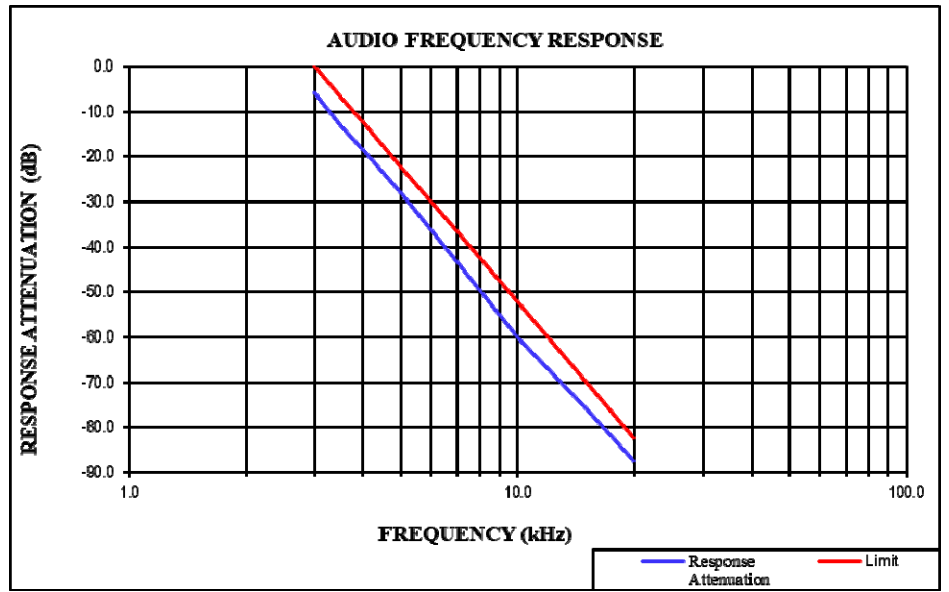

Channel Spacing: 25kHz		
Carrier Frequency: 154.0125 MHz		
Audio Frequency (kHz)	Response Attenuation (dB)	Limit (dB)
3.0	-6.6	0.0
3.5	-12.8	-2.7
4.0	-18.9	-5.0
5.0	-29.5	-8.9
7.0	-44.8	-14.7
10.0	-61.0	-20.9
15.0	-75.8	-28.0
20.0	-86.5	-28.0
30.0	-86.9	-28.0
50.0	-87.3	-28.0
70.0	-87.6	-28.0

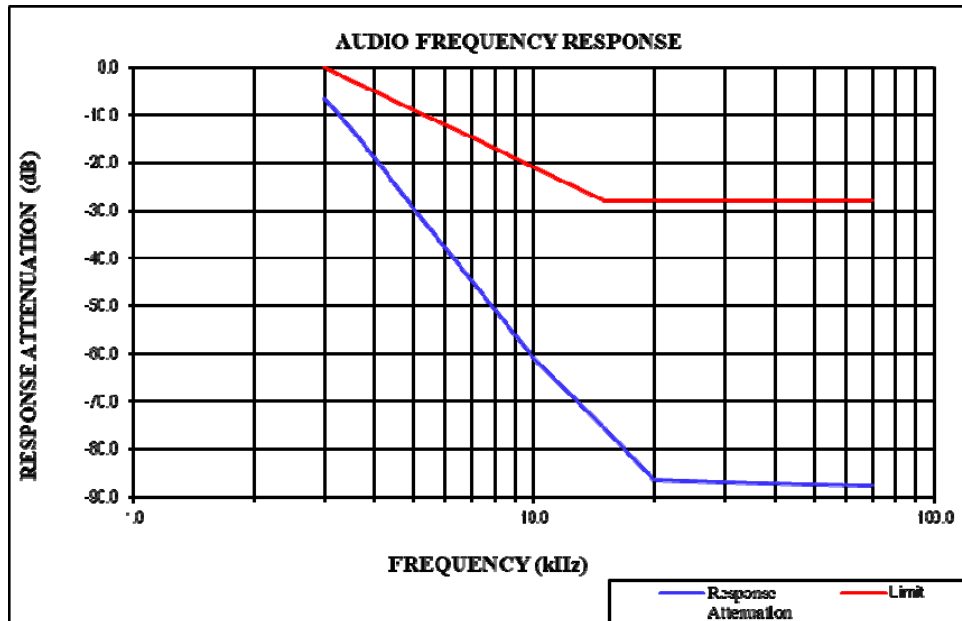

4 – OCCUPIED BANDWIDTH & EMISSION MASK

Applicable Standard

FCC §2.1049, §22.357, § 22.731, §74.462, §80.205, §80.207,§90.209 and §90.210

Test Procedure

The RF output of the transmitter was connected to the input of the spectrum analyzer through sufficient attenuation.

The resolution bandwidth of the spectrum analyzer was set at 100 Hz or 300 Hz and the spectrum was recorded in the frequency band ±50 kHz from the carrier frequency.

Test Data

Test Mode: Transmitting

Test Result: Compliance. Please refer to following table and plots.

Test Mode	Test Channel	Test Frequency (MHz)	High Power Level		Low Power Level		Note
			99% Occupied Bandwidth (kHz)	26dB Emission Bandwidth (kHz)	99% Occupied Bandwidth (kHz)	26dB Emission Bandwidth (kHz)	
FM 12.5kHz	Low	136.0125	5.090	5.390	5.190	5.490	FCC
	Middle	155.7525	5.190	5.390	5.190	5.490	FCC Part 90
	High	173.9875	7.485	10.380	5.090	5.390	FCC
	Additional	150.8125	5.090	5.390	5.190	5.390	FCC Part 22
	Additional	161.1000	5.190	5.390	5.190	5.390	FCC Part 74
4FSK 12.5kHz	Low	136.0125	7.385	9.580	7.086	9.180	FCC
	Middle	155.7525	6.986	8.980	7.186	9.580	FCC Part 90
	High	173.9875	7.285	9.380	7.086	8.680	FCC
	Additional	150.8125	7.186	8.780	7.385	9.680	FCC Part 22
	Additional	161.1000	6.986	9.180	7.485	9.500	FCC Part 74
FM 25kHz	Additional	150.8125	9.780	10.780	9.780	10.780	FCC Part 22
	Additional	154.0125	14.970	15.990	15.170	15.990	FCC Part 80
	Additional	161.1000	9.780	10.680	9.780	10.680	FCC Part 74

Note: Emission bandwidth was based on calculation method instead of measurement.

Emission Designator: Per CFR 47 §2.201& §2.202, BW = 2M + 2D

For FM Mode (Channel Spacing: 12.5 kHz)

Emission Designator: 11K0F3E

In this case, the maximum modulating frequency is 3.0 kHz with a 2.5 kHz deviation.

$$BW = 2(M+D) = 2*(3.0 \text{ kHz} + 2.5 \text{ kHz}) = 11 \text{ kHz} = 11K0$$

F3E portion of the designator represents an FM voice transmission

Therefore, the entire designator for 12.5 kHz channel spacing FM mode is 11K0F3E.

For FM Mode (Channel Spacing: 25 kHz)

Emission Designator: 16K0F3E

In this case, the maximum modulating frequency is 3.0 kHz with a 5.0 kHz deviation.

$$BW = 2(M+D) = 2*(3.0 \text{ kHz} + 5.0 \text{ kHz}) = 16 \text{ kHz} = 16K0$$

F3E portion of the designator represents an FM voice transmission

Therefore, the entire designator for 25 kHz channel spacing FM mode is 16K0F3E.

For Digital Mode (Channel Spacing: 12.5 kHz)

Emission Designator: 7K60F1D and 7K60F1E

The 99% energy rule (title 47CFR 2.1049) was used for digital mode. It basically states that 99% of the modulation energy falls within X kHz, in this case, 7.60 kHz. The emission mask was obtained from 47CFR 90.210(d).

F1D and F1E portion of the designator indicates digital information.

Therefore, the entire designator for 12.5 kHz channel spacing digital mode is 7K60F1D and 7K60F1E.

FM, 12.5kHz, High Power:

Low Channel

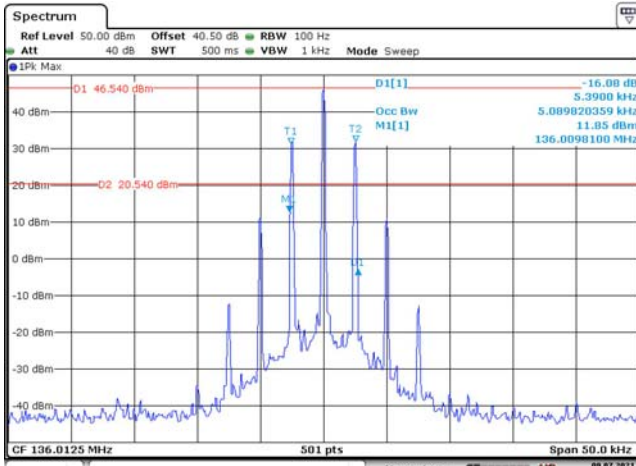

Date: 9.JUL.2021 11:44:20

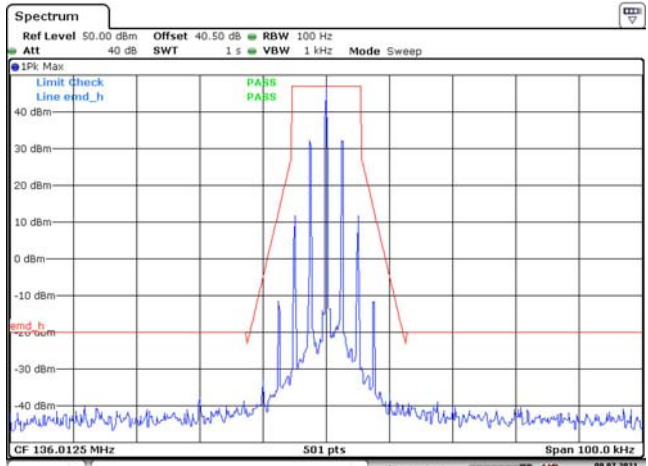

Date: 9.JUL.2021 11:51:27

Middle Channel

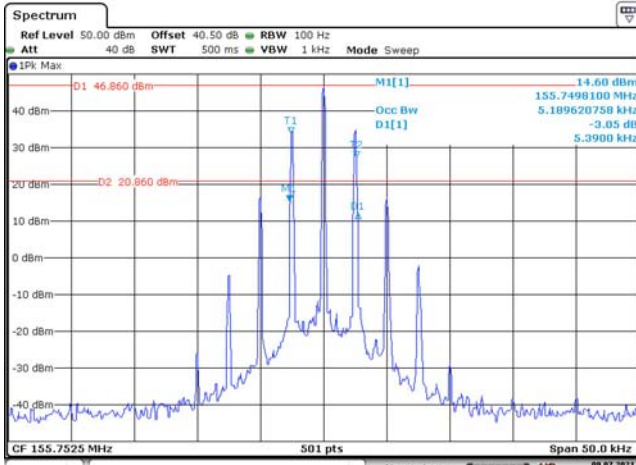

Date: 9.JUL.2021 12:06:15

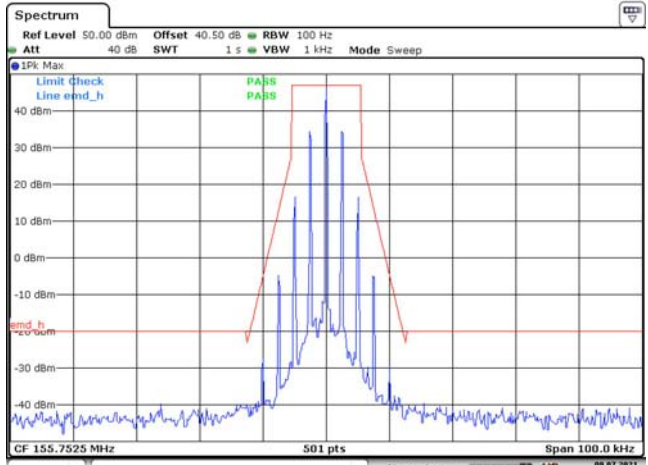

Date: 9.JUL.2021 11:54:27

High Channel

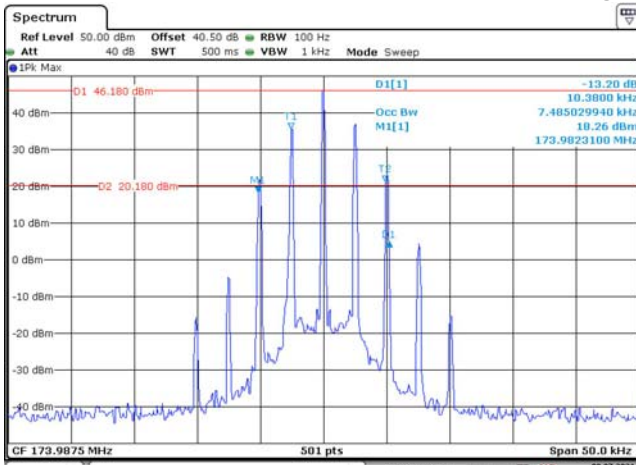

Date: 9.JUL.2021 12:14:18

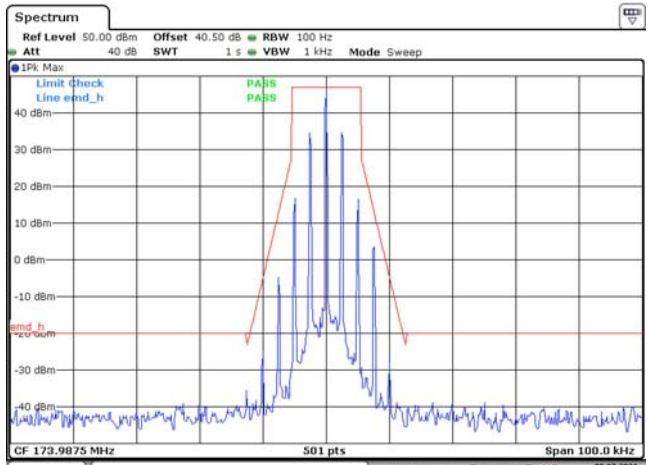

Date: 9.JUL.2021 12:24:24

Additional Channel Part 22, 150.8125 MHz

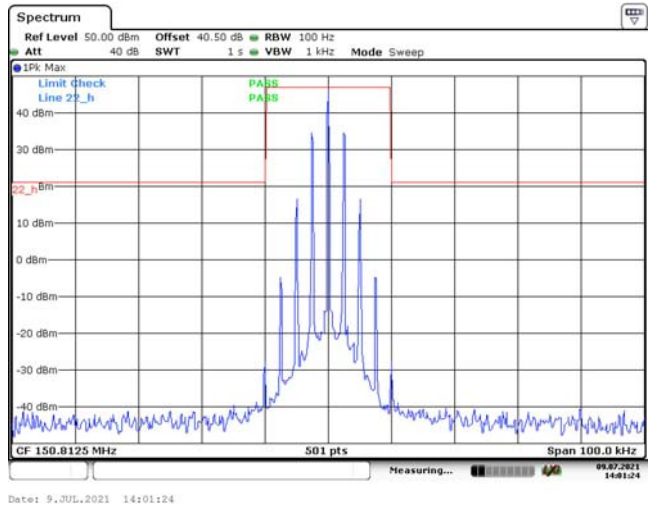
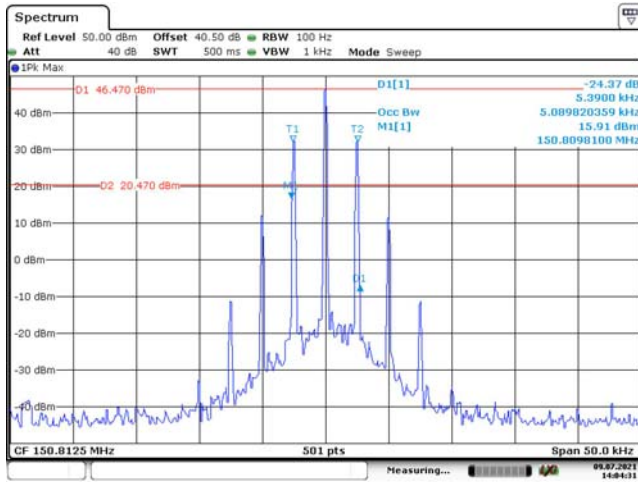

Additional Channel Part 74, 161.1 MHz

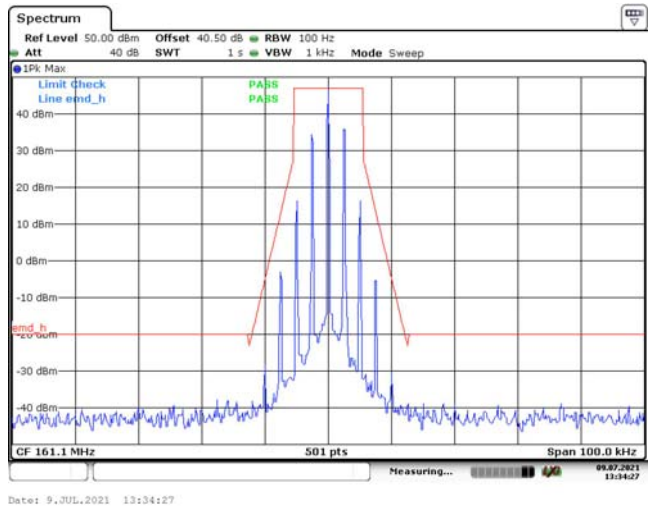
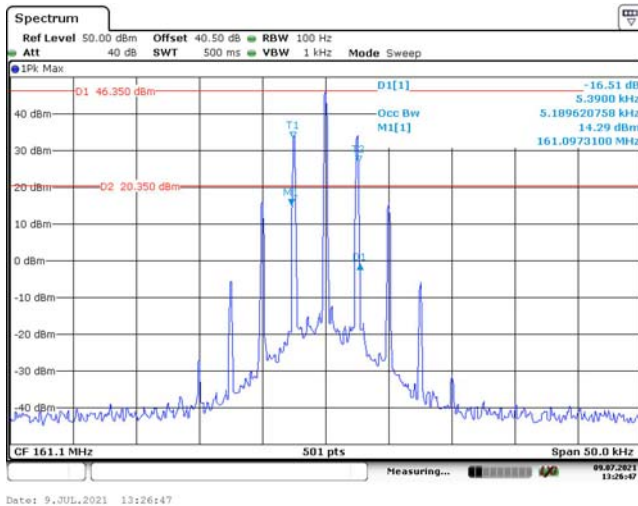

FM, 12.5kHz, Low Power:

Low Channel

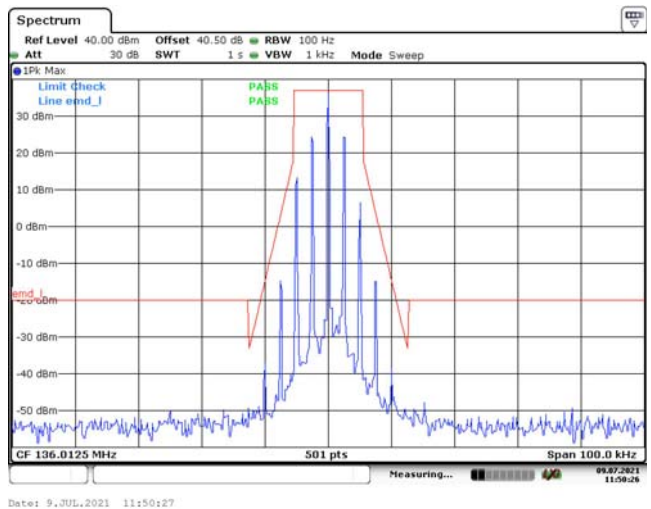
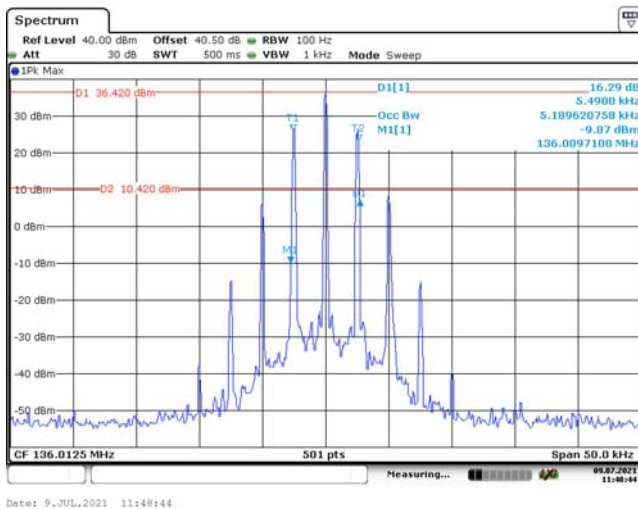

Middle Channel

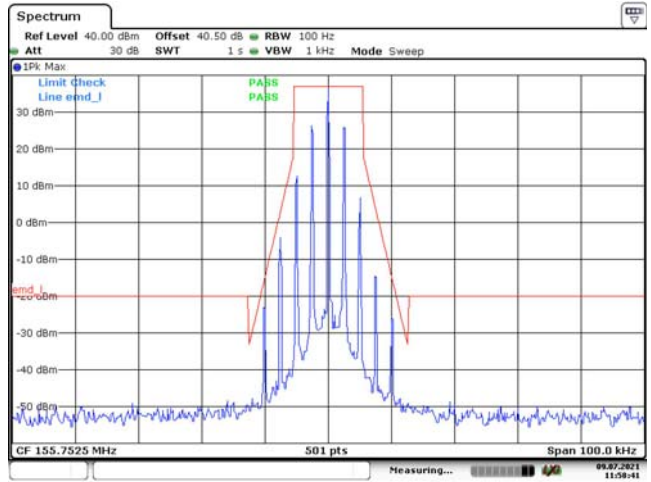
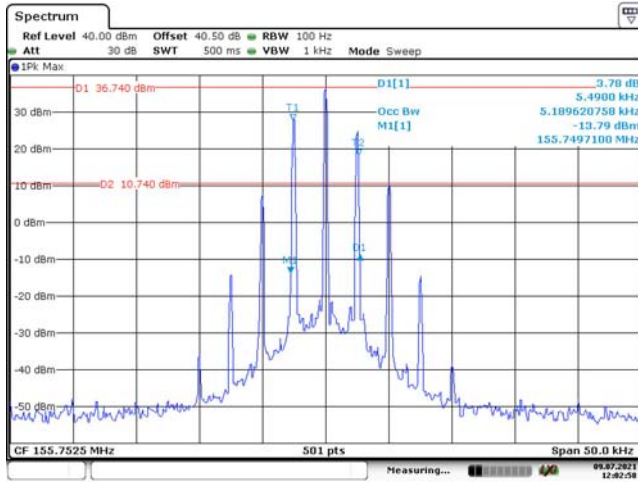

High Channel

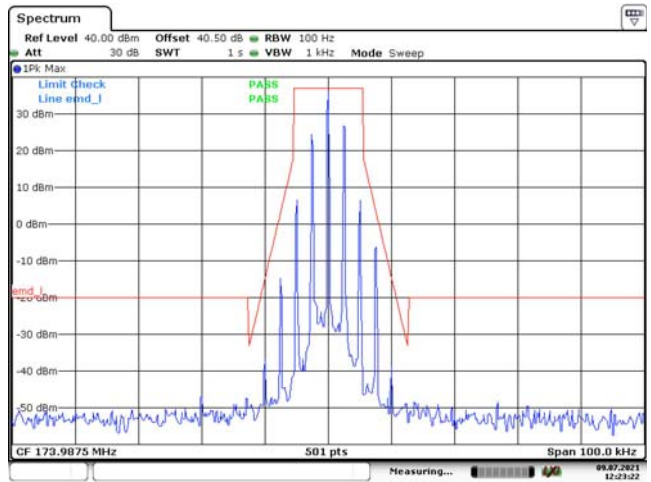
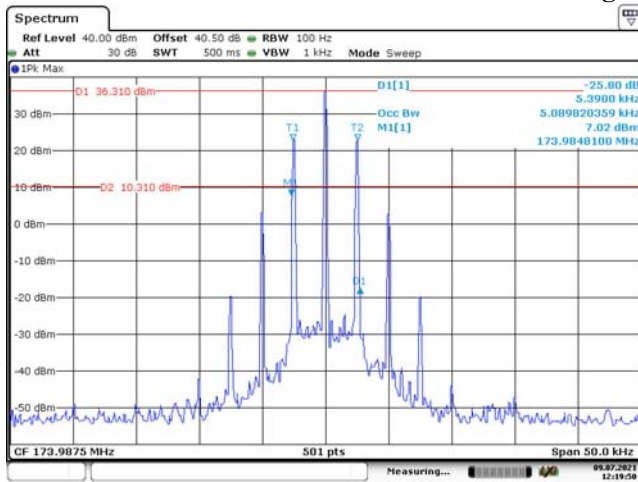

Additional Channel Part 22, 150.8125 MHz

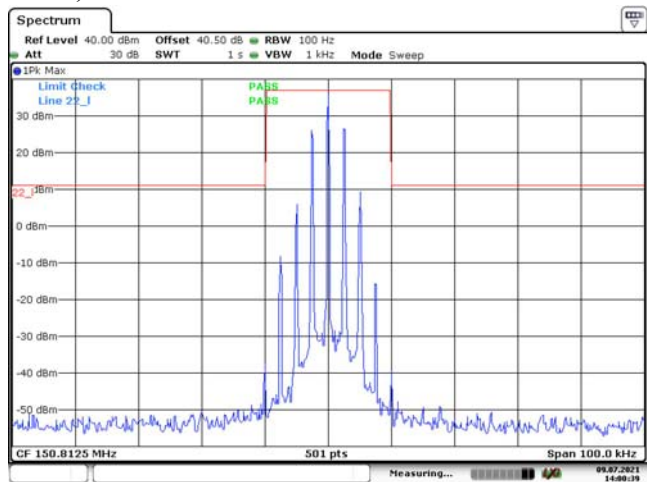
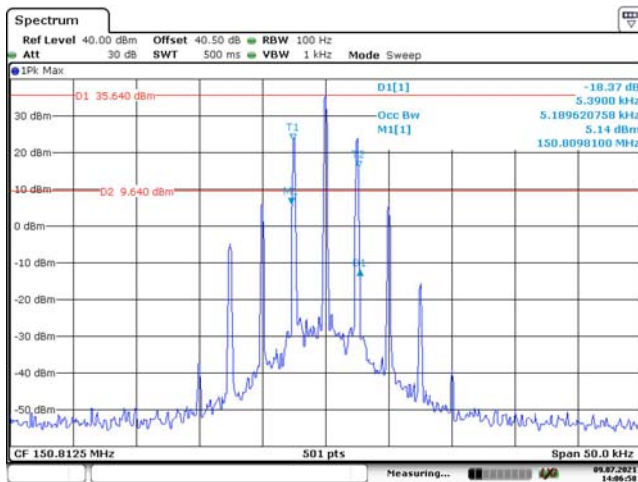

Additional Channel Part 74, 161.1 MHz

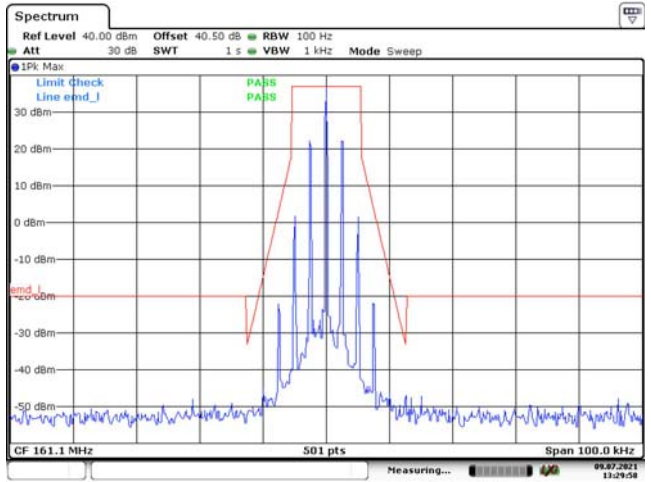
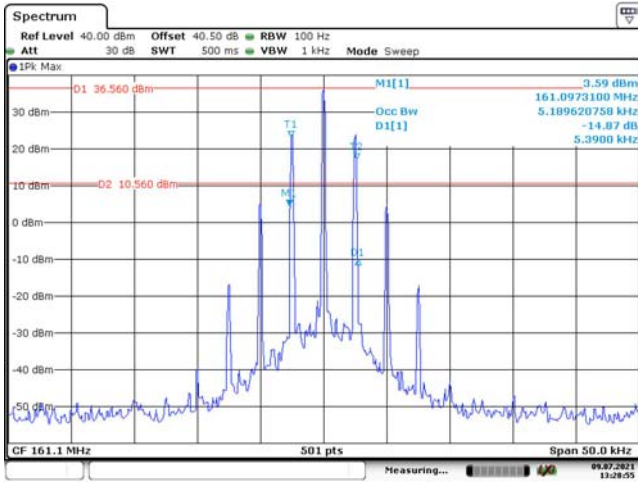

4FSK, 12.5kHz, High Power:

Low Channel

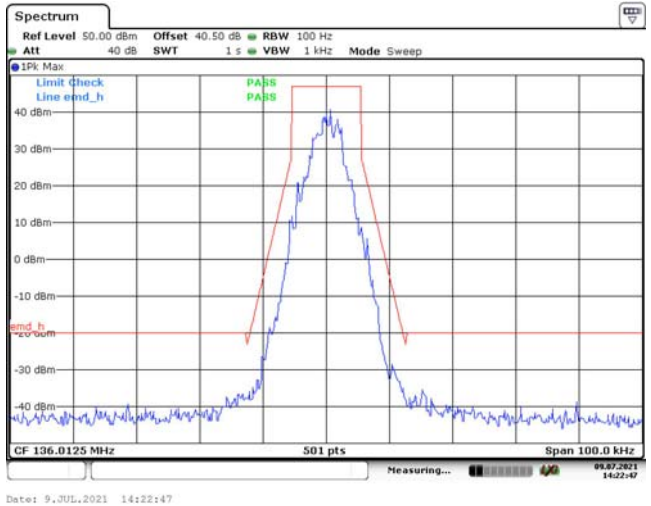
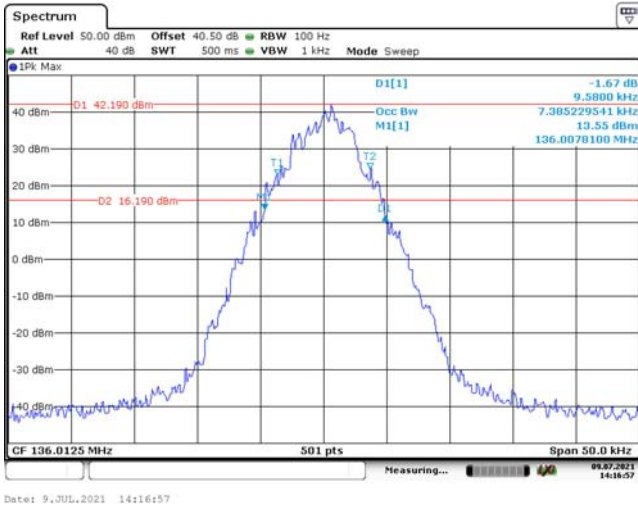

Middle Channel

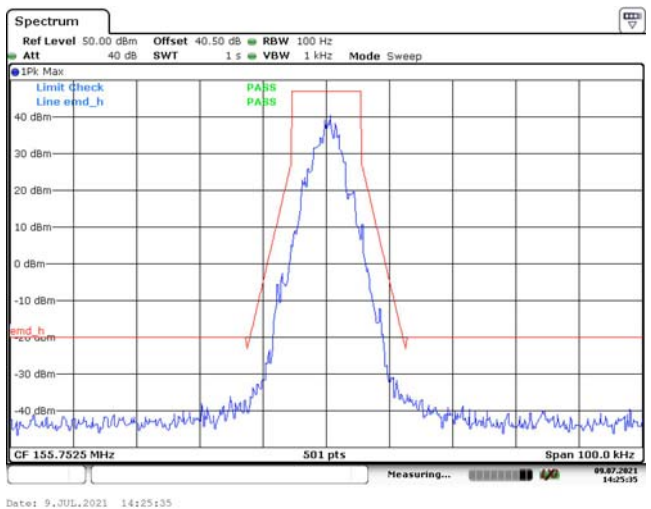
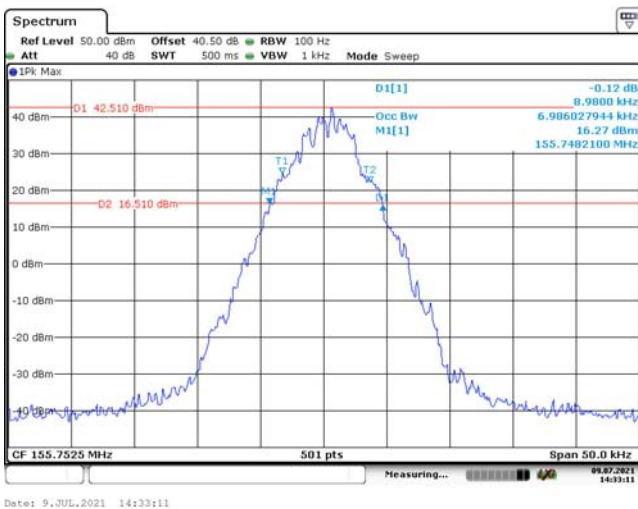

High Channel

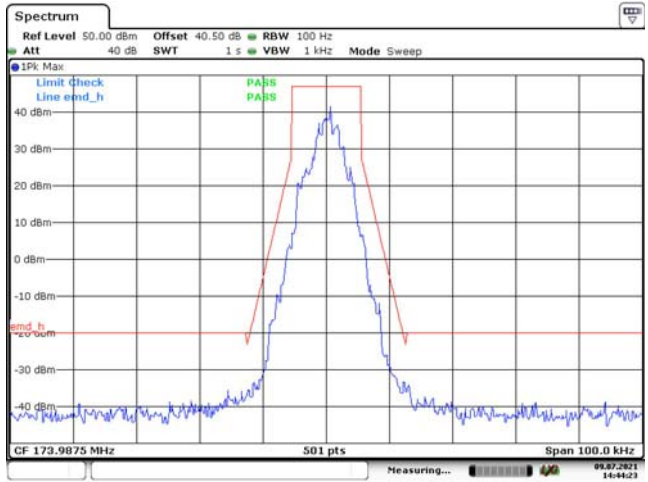
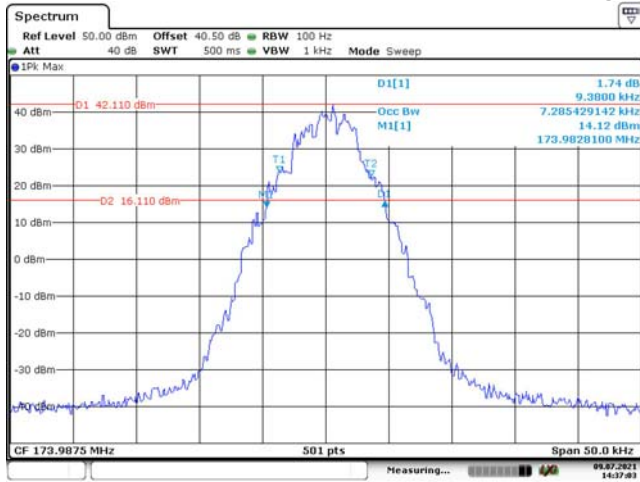

Additional Channel Part 22, 150.8125 MHz

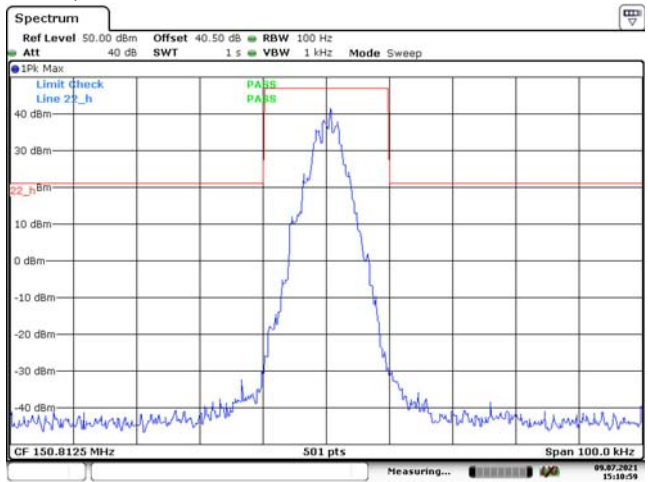
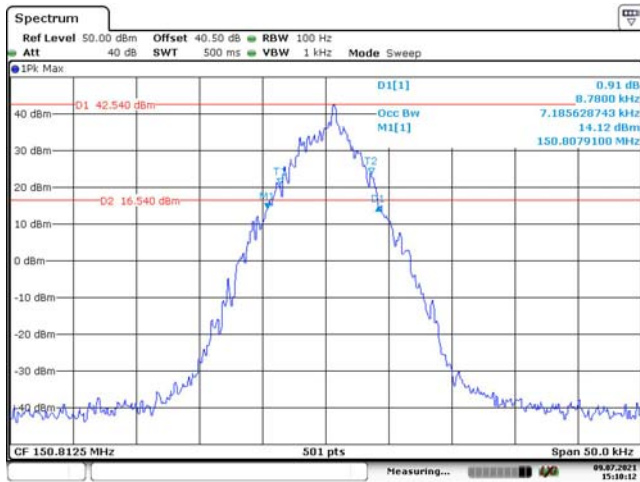

Additional Channel Part 74, 161.1MHz

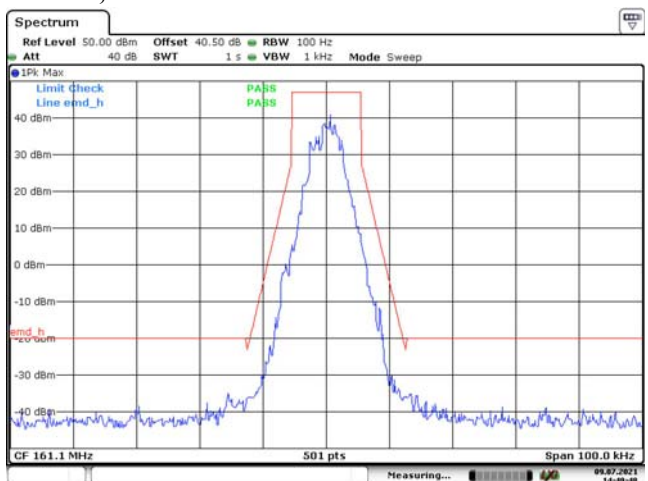
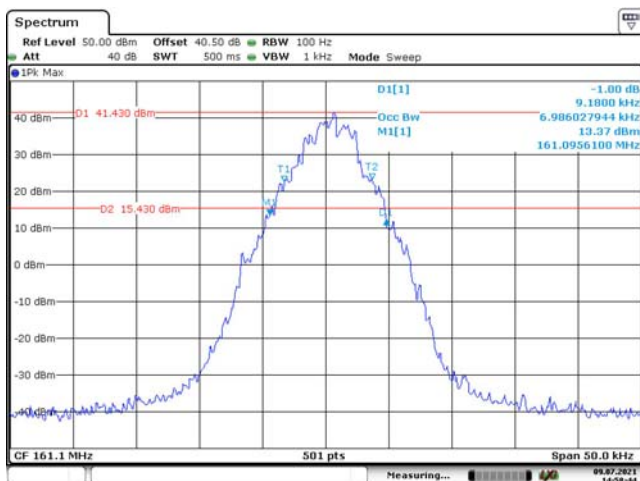

4FSK, 12.5kHz, Low Power:

Low Channel

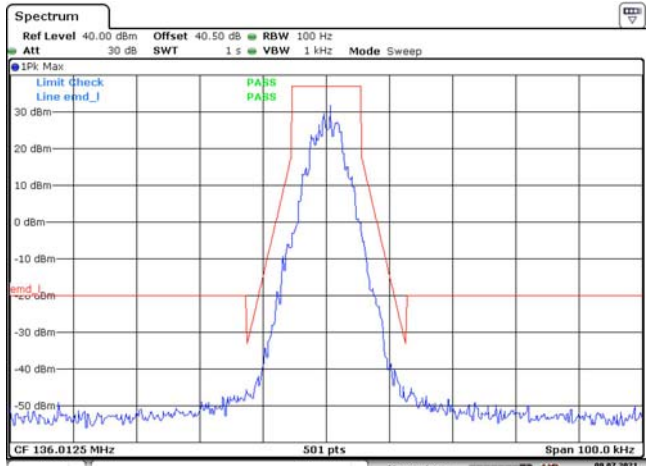
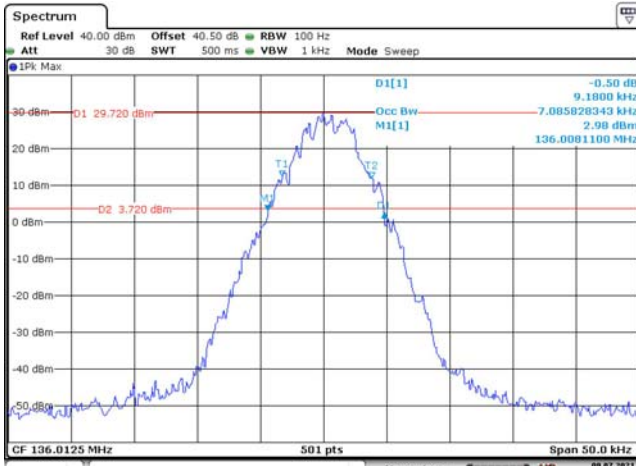

Middle Channel

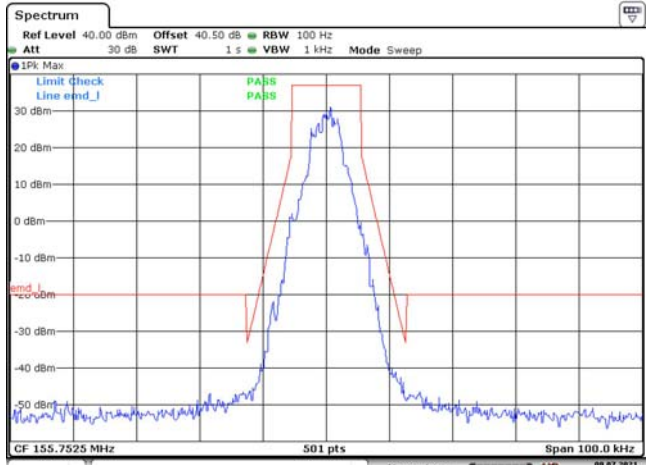
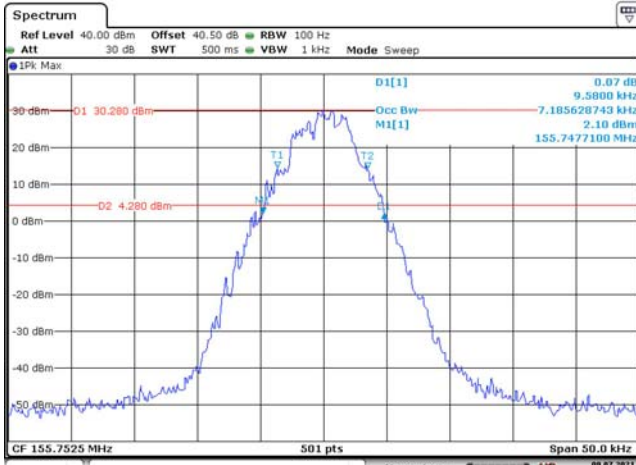

High Channel

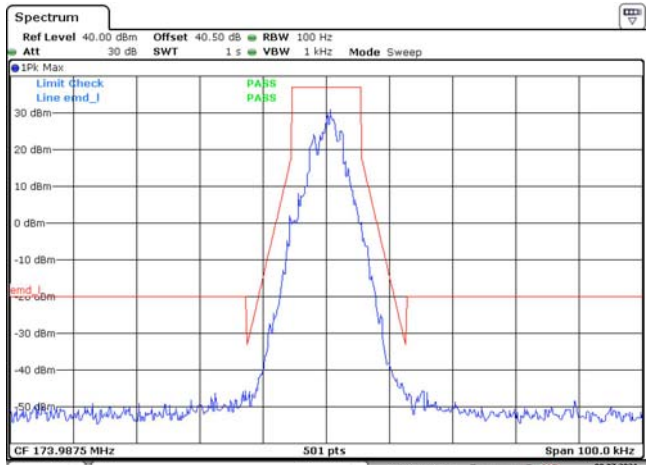
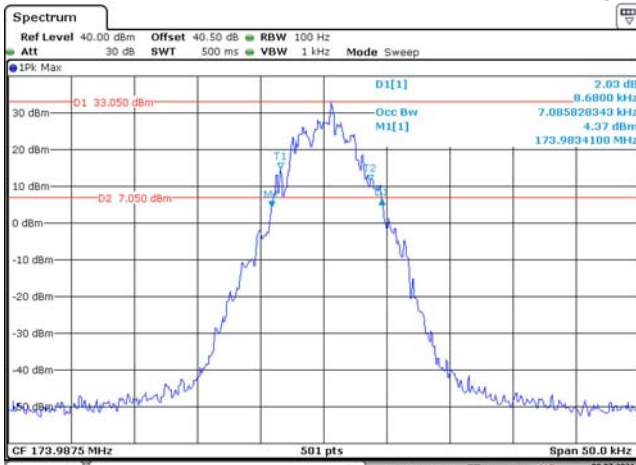

Additional Channel Part 22, 150.8125 MHz

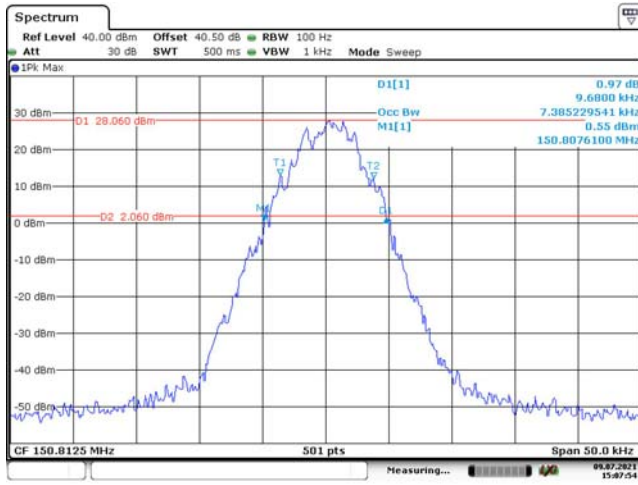

Date: 9.JUL.2021 15:07:54

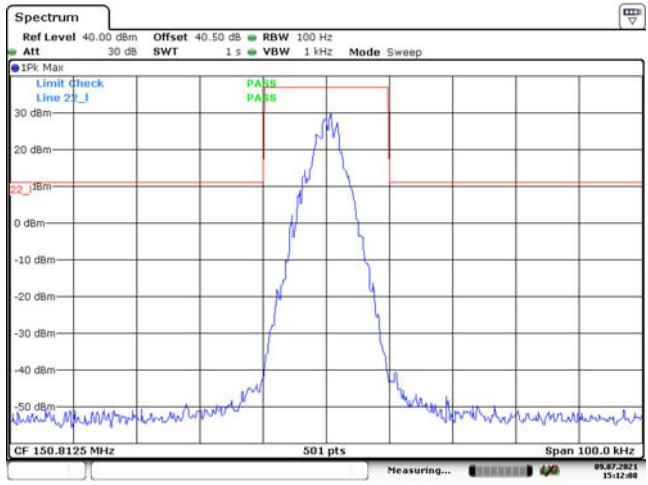

Date: 9.JUL.2021 15:12:09

Additional Channel Part 74, 161.1 MHz

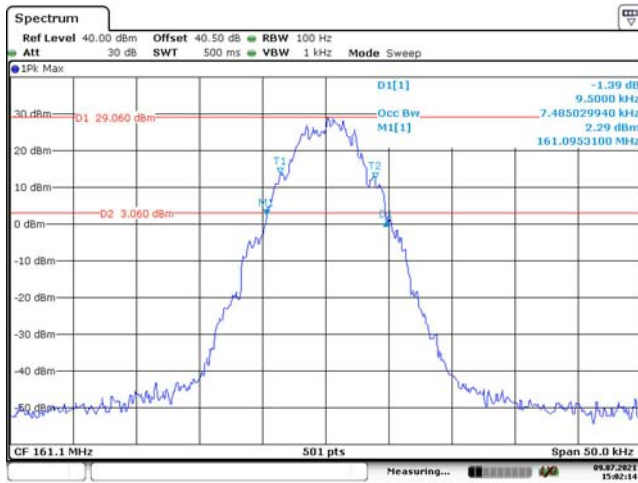

Date: 9.JUL.2021 15:02:14

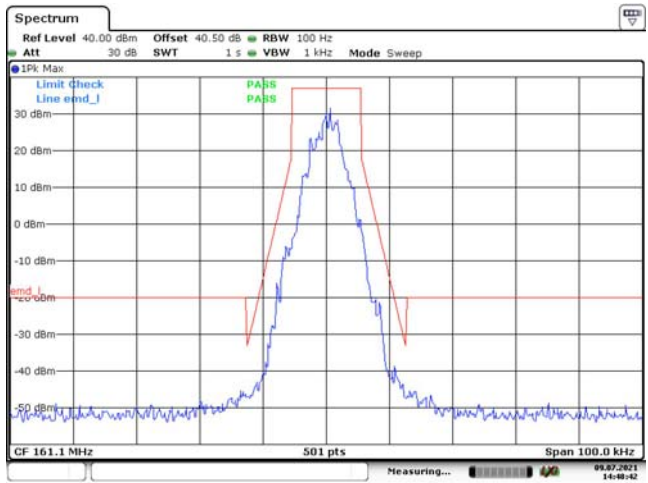

Date: 9.JUL.2021 14:48:42

FM, 25 kHz, High Power:

Additional Channel Part 22, 150.8125 MHz

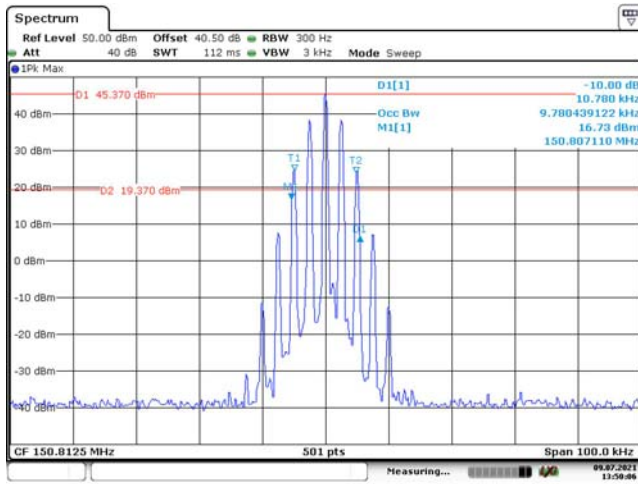

Date: 9.JUL.2021 13:50:06

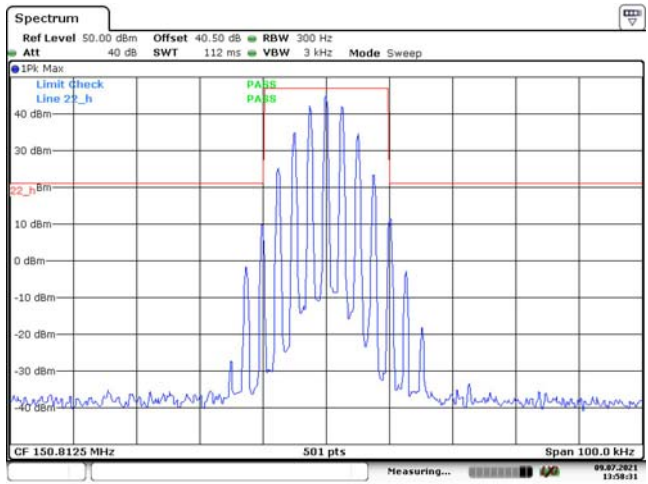

Date: 9.JUL.2021 13:58:32

Additional Channel Part 80, 154.0125 MHz

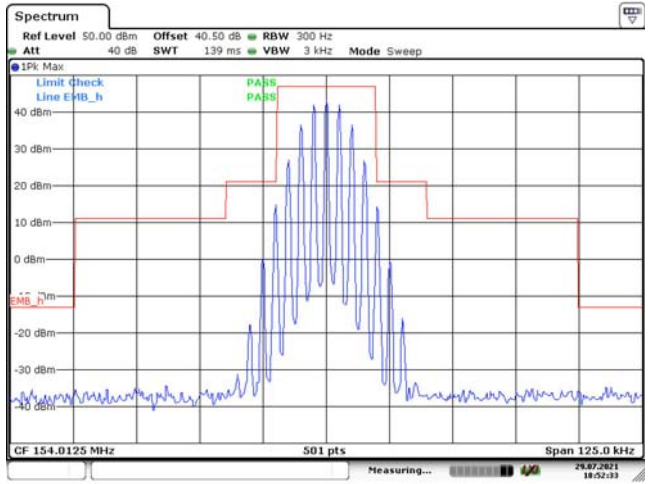
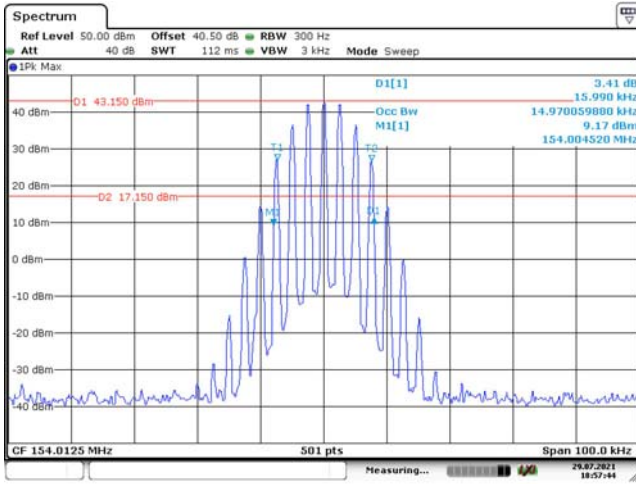

Date: 29.JUL.2021 18:57:44

Date: 29.JUL.2021 18:52:33

Additional Channel Part 74, 161.1 MHz

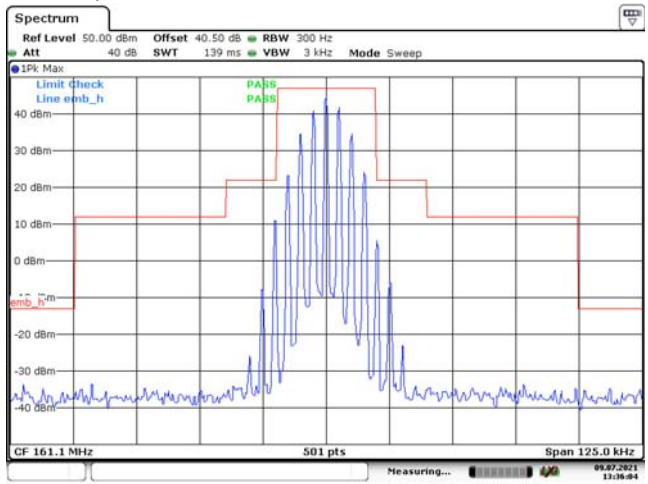
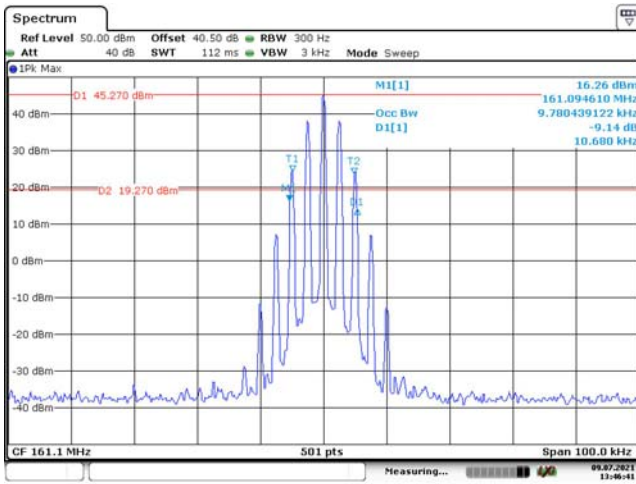

Date: 9.JUL.2021 13:46:41

Date: 9.JUL.2021 13:36:04

FM, 25 kHz, Low Power:

Additional Channel Part 22, 150.8125 MHz

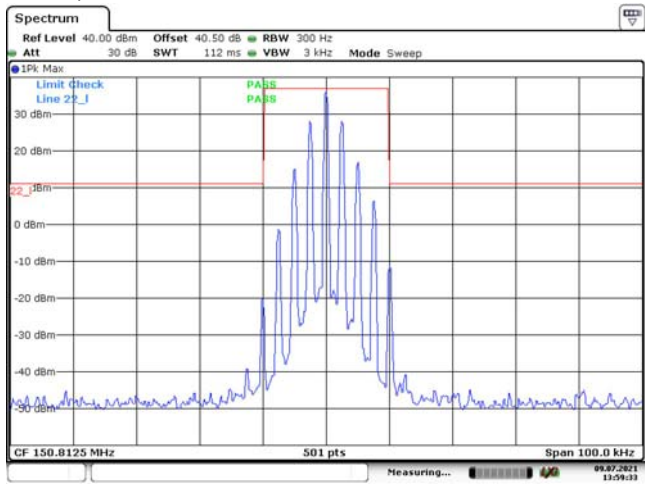
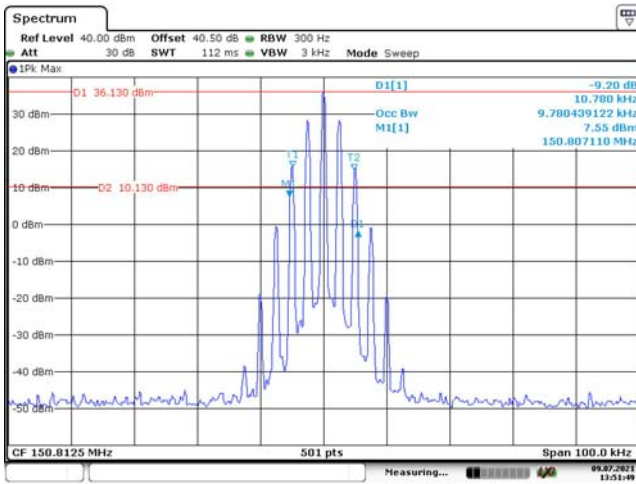

Date: 9.JUL.2021 13:51:49

Date: 9.JUL.2021 13:59:33

Additional Channel Part 80, 154.0125 MHz

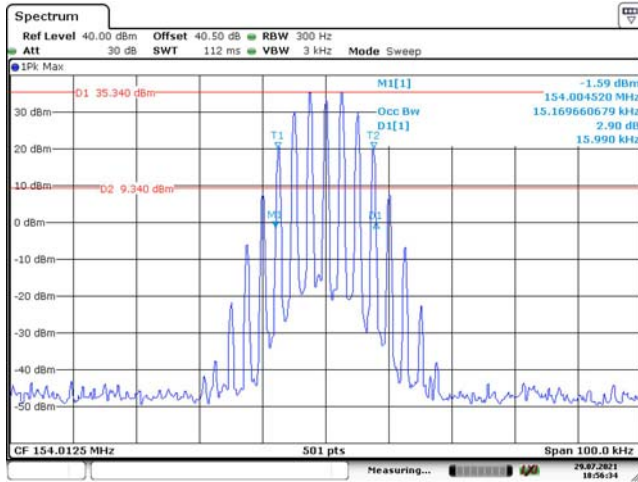

Date: 29.JUL.2021 18:56:35

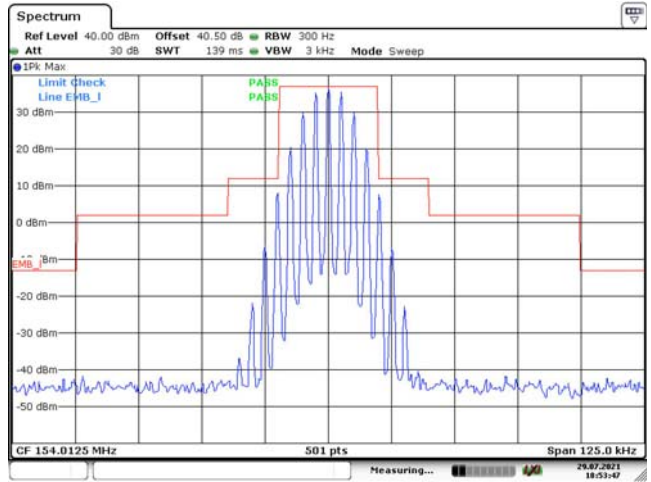

Date: 29.JUL.2021 18:53:47

Additional Channel Part 74, 161.1 MHz

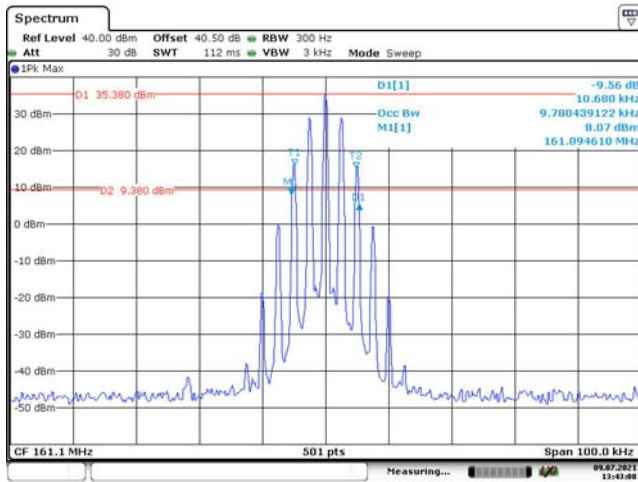

Date: 9.JUL.2021 13:43:07

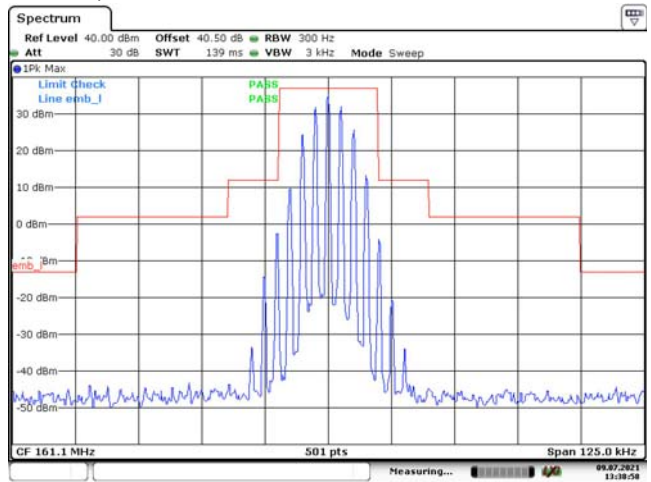

Date: 9.JUL.2021 13:38:58

5 - SPURIOUS EMISSIONS AT ANTENNA TERMINALS

Applicable Standard

FCC §2.1051, §22.359, §74.462, §80.211, and §90.210

Test Procedure

The RF output of the EUT was connected to a spectrum analyzer through appropriate attenuation. The resolution bandwidth of the spectrum analyzer was set at 100kHz for below 1GHz, and 1MHz for above 1GHz. Sufficient scans were taken to show any out of band emissions up to 10th harmonic.

Test Data

Test Mode: Transmitting

Test Result: Compliance. Please refer to following plots.

Test performed at high power level with Band Rejector Filter, please refer to the following table.

FM, 12.5kHz:

Low Channel, 136.0125 MHz

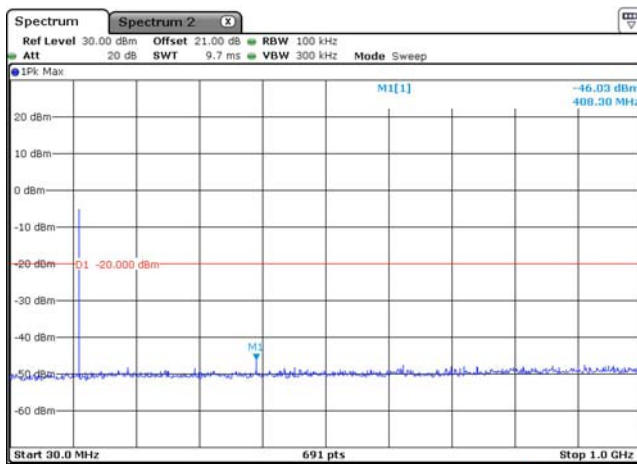

Date: 8 JUL 2021 18:50:40

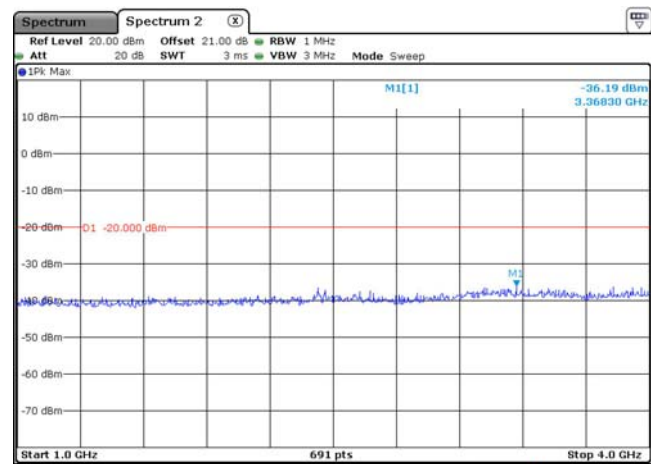

Date: 8 JUL 2021 18:50:58

Middle Channel, 155.7525 MHz

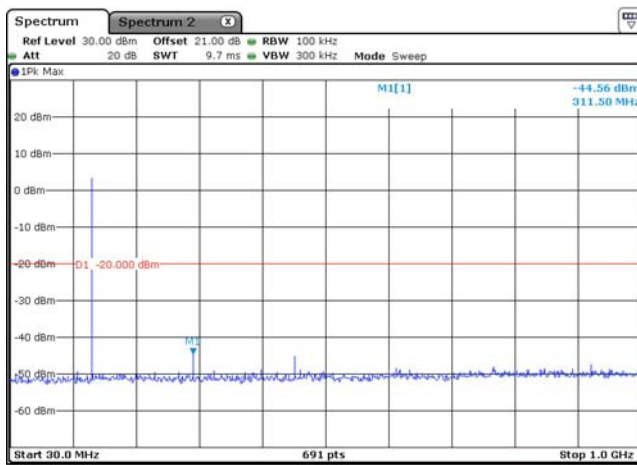

Date: 8 JUL 2021 18:52:07

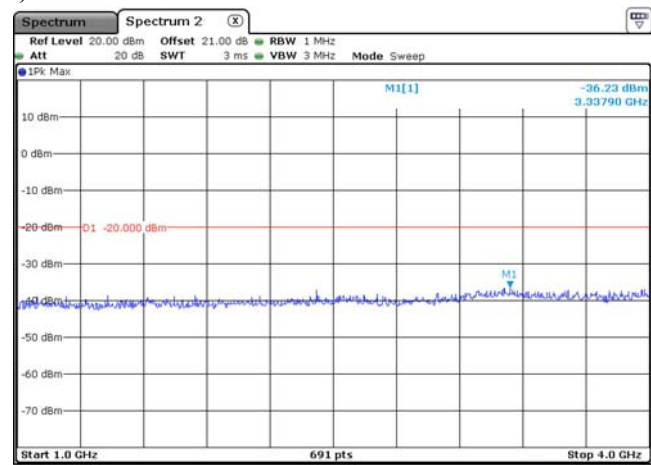

Date: 8 JUL 2021 18:51:49

High Channel, 173.9875 MHz

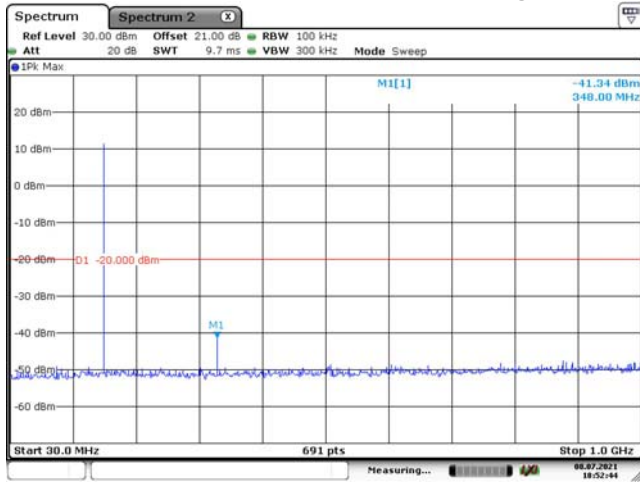

Date: 8.JUL.2021 18:52:44

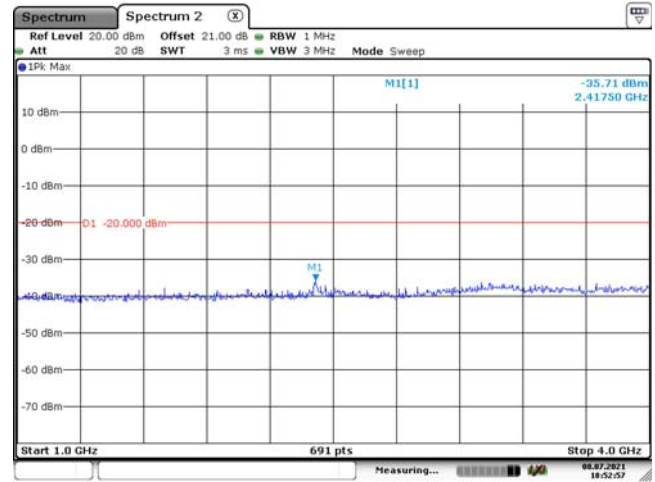

Date: 8.JUL.2021 18:52:57

4FSK, 12.5kHz:

Low Channel, 136.0125 MHz

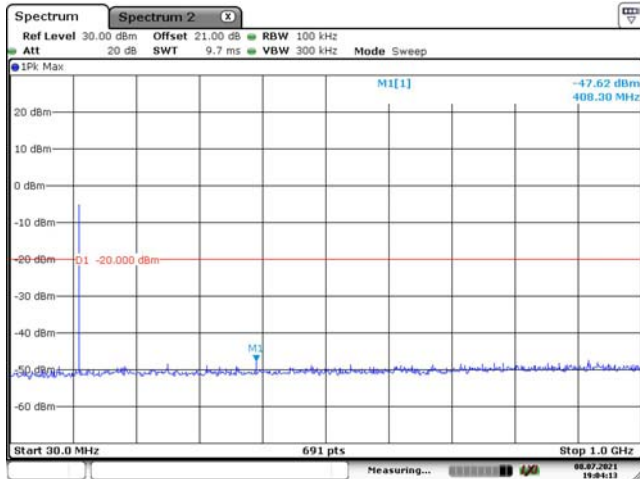

Date: 8.JUL.2021 19:04:13

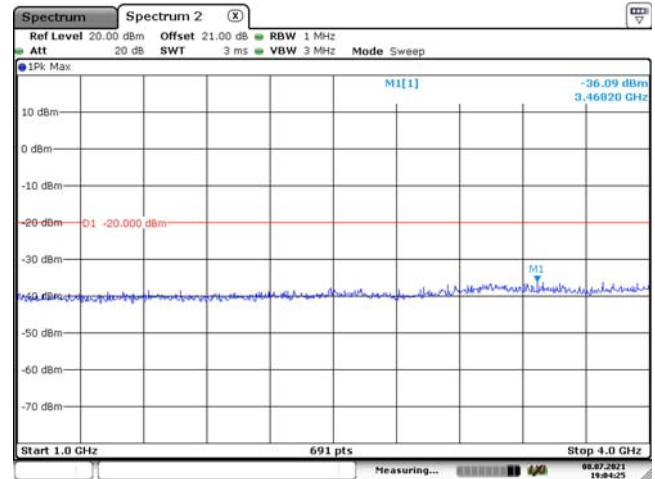

Date: 8.JUL.2021 19:04:25

Middle Channel, 155.7525 MHz

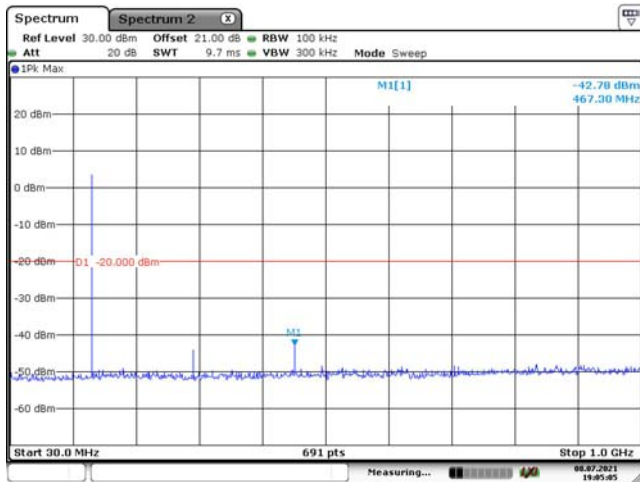

Date: 8.JUL.2021 19:05:05

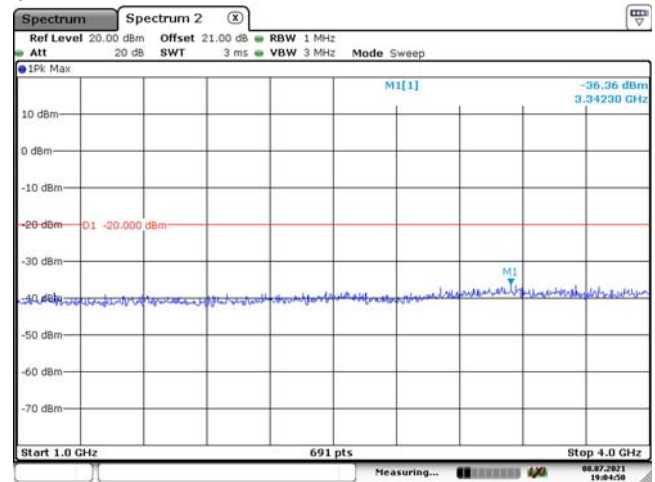

Date: 8.JUL.2021 19:04:56

High Channel, 173.9875 MHz

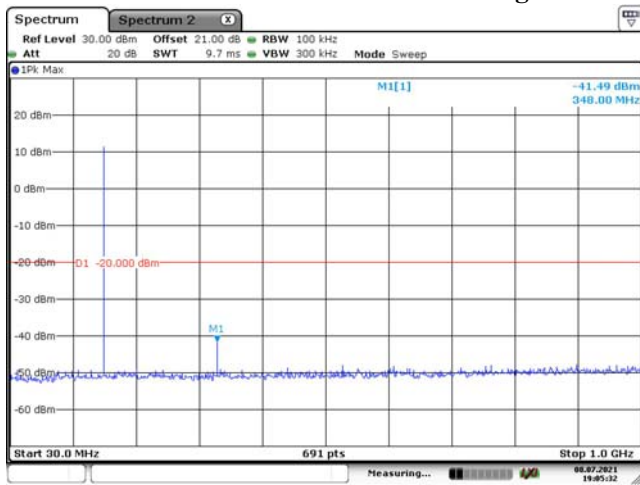

Date: 8.JUL.2021 19:05:32

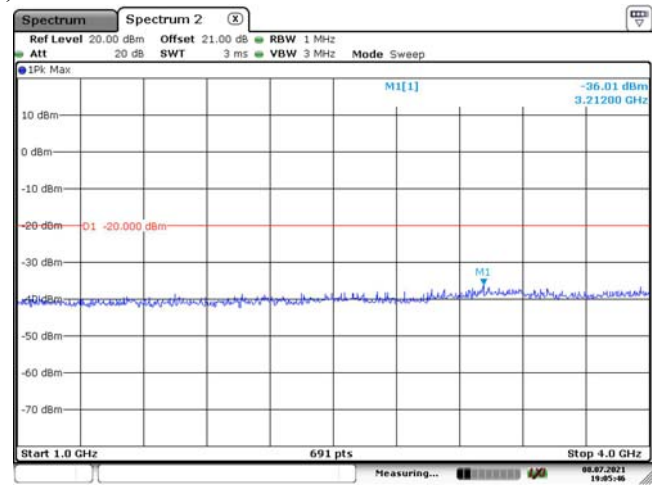

Date: 8.JUL.2021 19:05:46

Part 80:

FM, 25kHz, 154.0125 MHz

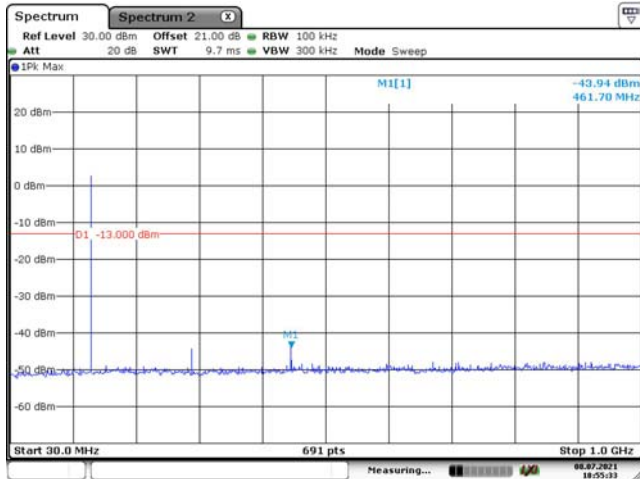

Date: 8.JUL.2021 18:55:33

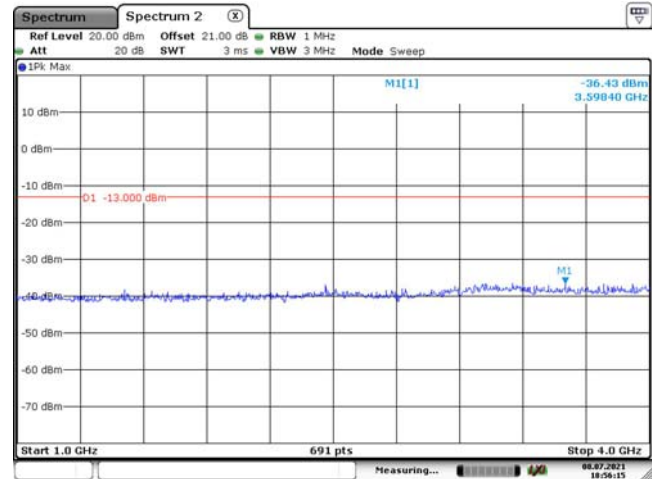

Date: 8.JUL.2021 18:56:15

Part 74:

FM, 12.5kHz, 161.1 MHz

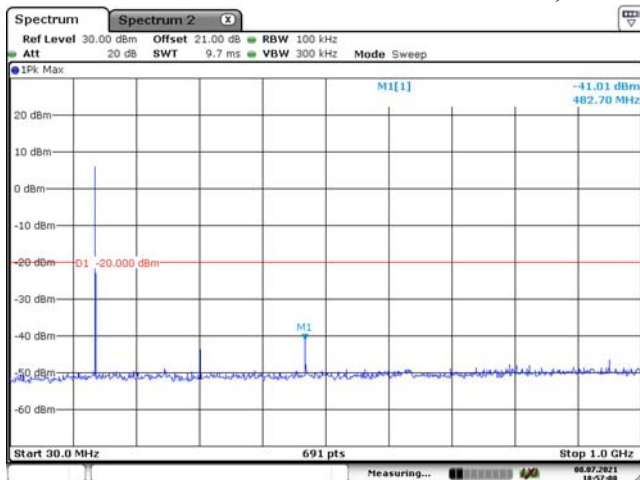

Date: 8.JUL.2021 18:57:08

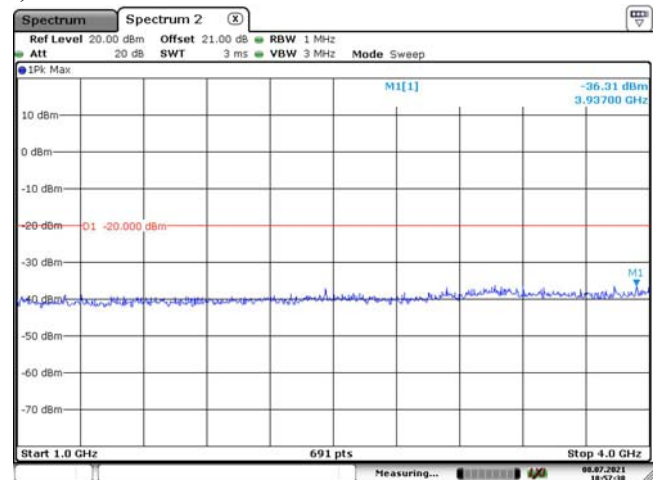

Date: 8.JUL.2021 18:57:38

FM, 25kHz, 161.1 MHz

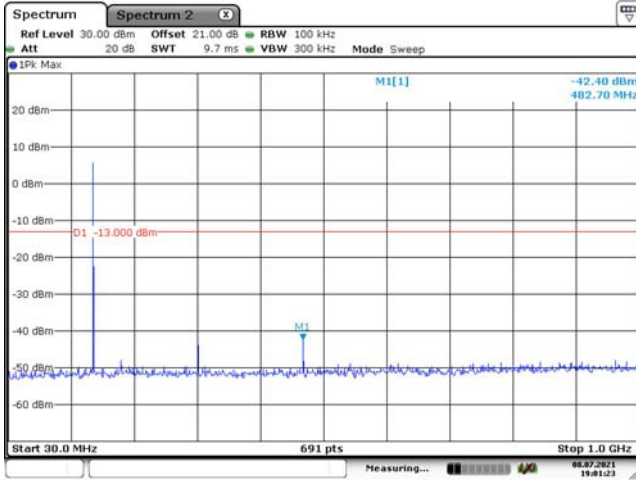

Date: 8.JUL.2021 19:01:23

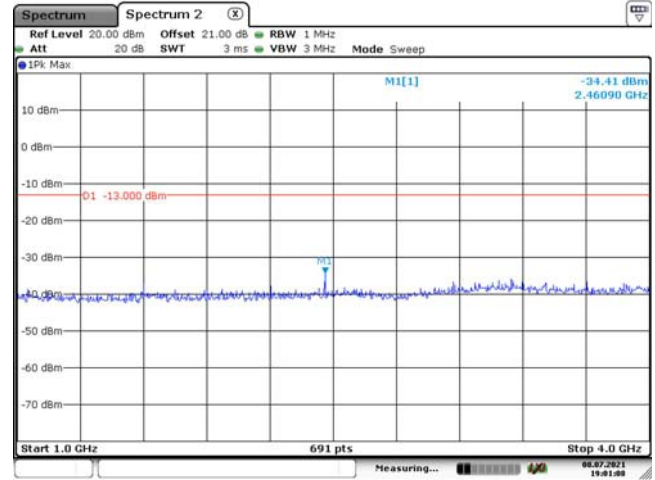

Date: 8.JUL.2021 19:01:09

4FSK, 12.5kHz, 161.1 MHz

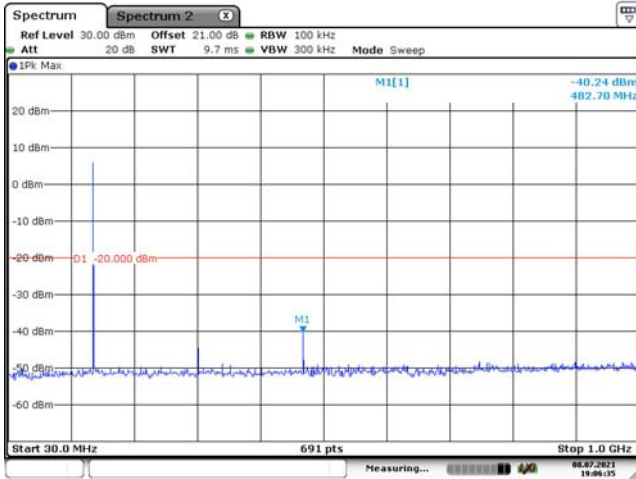

Date: 8.JUL.2021 19:06:35

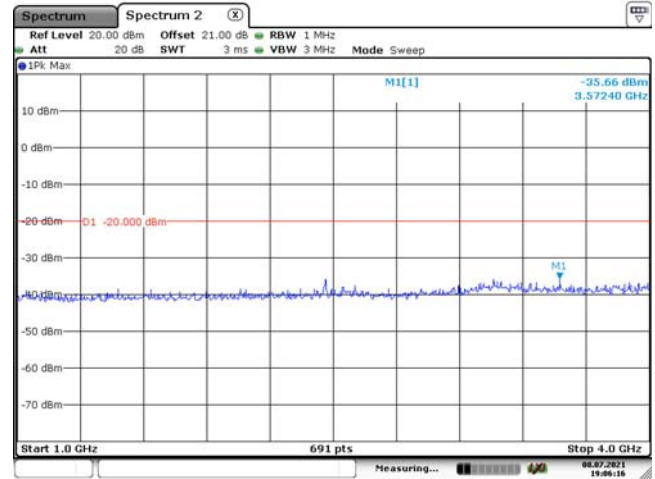

Date: 8.JUL.2021 19:06:16

Part 22:

FM, 12.5kHz, 150.8125 MHz

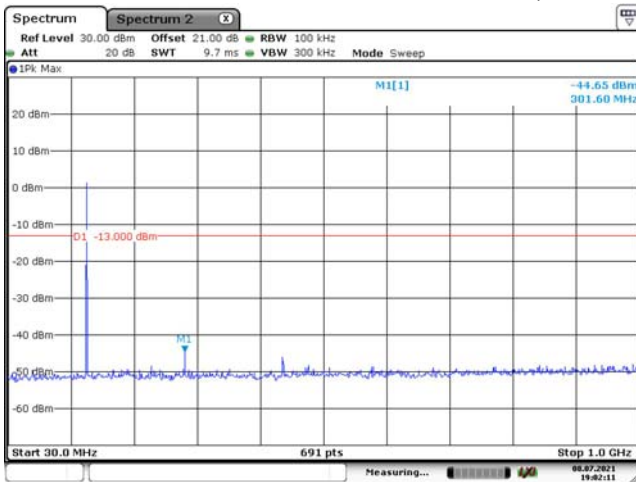

Date: 8.JUL.2021 19:02:11

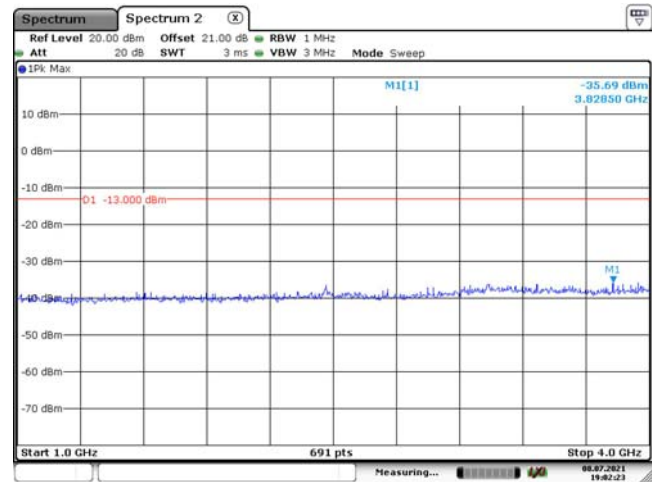

Date: 8.JUL.2021 19:02:24

FM,25kHz, 150.8125 MHz

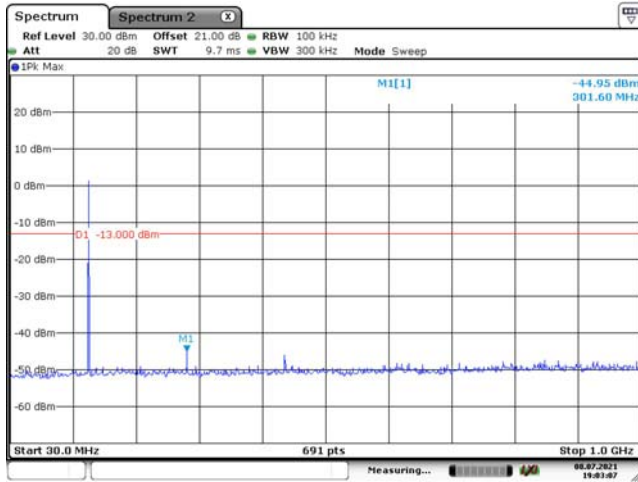

Date: 8.JUL.2021 19:03:07

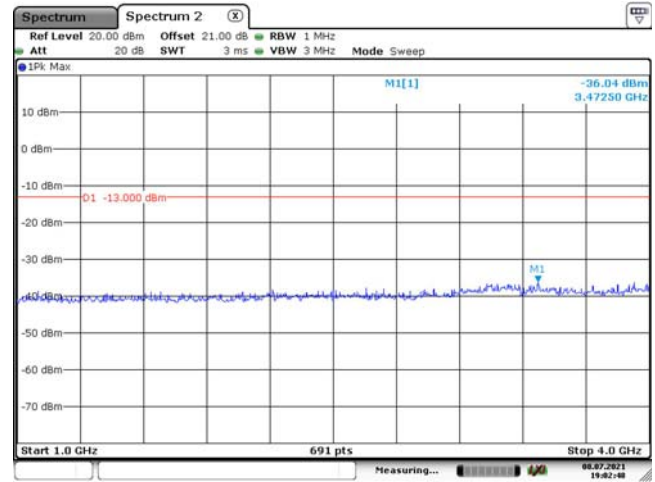

Date: 8.JUL.2021 19:02:48

4FSK, 12.5kHz, 150.8125 MHz

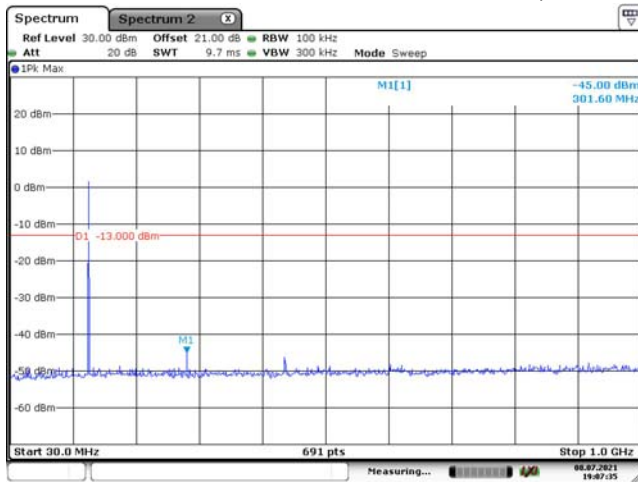

Date: 8.JUL.2021 19:07:35

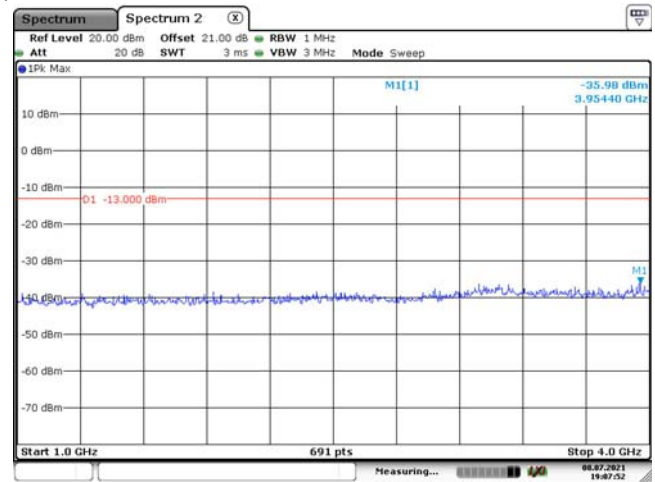

Date: 8.JUL.2021 19:07:52

6 - RADIATED SPURIOUS EMISSIONS

Applicable Standard

FCC §2.1053, §22.861, §74.462, §80.211 and §90.210

Test Procedure

The transmitter was placed on a wooden turntable, and it was transmitting into a non-radiating load, which was also placed on the turntable.

The measurement antenna was placed at a distance of 3 meters from the EUT. During the tests, the antenna height and polarization as well as EUT azimuth were varied in order to identify the maximum level of emissions from the EUT. The test was performed by placing the EUT on 3-orthogonal axis.

The frequency range up to tenth harmonic of the fundamental frequency was investigated.

Remove the EUT and replace it with substitution antenna. A signal generator was connected to the substitution antenna by a non-radiating cable. The absolute levels of the spurious emissions were measured by the substitution.

Spurious emissions in dB = 10 lg (TXpwr in Watts/0.001)-the absolute level

Test Data

Test Mode: Transmitting

Test Result: Compliance.

Test performed at high power level with Band Rejector Filter, *please refer to the following table.*

30MHz - 2GHz:

Frequency (MHz)	Polar (H/V)	Receiver Reading (dBµV)	Substituted Method			Absolute Level (dBm)	Limit (dBm)	Margin (dB)
			Substituted Level (dBm)	Antenna Gain (dBd/dBi)	Cable Loss (dB)			
FM, Frequency: 136.0125MHz-12.5 kHz								
272.03	H	36.24	-48.25	0.00	0.29	-48.54	-20.00	28.54
272.03	V	38.77	-43.39	0.00	0.29	-43.68	-20.00	23.68
408.04	H	44.50	-37.71	0.00	0.38	-38.09	-20.00	18.09
408.04	V	39.11	-40.51	0.00	0.38	-40.89	-20.00	20.89
544.05	H	40.49	-38.29	0.00	0.35	-38.64	-20.00	18.64
544.05	V	35.66	-41.23	0.00	0.35	-41.58	-20.00	21.58
680.06	H	34.69	-41.61	0.00	0.38	-41.99	-20.00	21.99
680.06	V	33.79	-39.92	0.00	0.38	-40.30	-20.00	20.30
816.08	H	33.69	-40.86	0.00	0.49	-41.35	-20.00	21.35
816.08	V	36.80	-34.86	0.00	0.49	-35.35	-20.00	15.35
952.09	H	35.20	-36.68	0.00	0.51	-37.19	-20.00	17.19
952.09	V	33.64	-35.07	0.00	0.51	-35.58	-20.00	15.58
1088.10	H	39.64	-64.20	7.46	0.99	-57.73	-20.00	37.73
1088.10	V	38.59	-65.67	7.46	0.99	-59.20	-20.00	39.20
1224.11	H	54.21	-48.97	7.54	1.11	-42.54	-20.00	22.54
1224.11	V	58.59	-45.64	7.54	1.11	-39.21	-20.00	19.21
1360.13	H	55.12	-48.43	8.72	1.20	-40.91	-20.00	20.91
1360.13	V	50.78	-53.49	8.72	1.20	-45.97	-20.00	25.97
4FSK, Frequency: 136.0125MHz-12.5 kHz								
272.03	H	35.60	-48.89	0.00	0.29	-49.18	-20.00	29.18
272.03	V	31.50	-50.66	0.00	0.29	-50.95	-20.00	30.95
408.04	H	32.50	-49.71	0.00	0.38	-50.09	-20.00	30.09
408.04	V	28.53	-51.09	0.00	0.38	-51.47	-20.00	31.47
544.05	H	33.40	-45.38	0.00	0.35	-45.73	-20.00	25.73
544.05	V	28.35	-48.54	0.00	0.35	-48.89	-20.00	28.89
680.06	H	30.50	-45.80	0.00	0.38	-46.18	-20.00	26.18
680.06	V	28.25	-45.46	0.00	0.38	-45.84	-20.00	25.84
816.08	H	32.00	-42.55	0.00	0.49	-43.04	-20.00	23.04
816.08	V	29.30	-42.36	0.00	0.49	-42.85	-20.00	22.85
952.09	H	33.41	-38.47	0.00	0.51	-38.98	-20.00	18.98
952.09	V	30.60	-38.11	0.00	0.51	-38.62	-20.00	18.62
1088.10	H	36.98	-66.86	7.46	0.99	-60.39	-20.00	40.39
1088.10	V	36.48	-67.78	7.46	0.99	-61.31	-20.00	41.31
1224.11	H	57.73	-45.45	7.54	1.11	-39.02	-20.00	19.02
1224.11	V	54.62	-49.61	7.54	1.11	-43.18	-20.00	23.18
1360.13	H	54.25	-49.30	8.72	1.20	-41.78	-20.00	21.78
1360.13	V	51.28	-52.99	8.72	1.20	-45.47	-20.00	25.47

Frequency (MHz)	Polar (H/V)	Receiver Reading (dBµV)	Substituted Method			Absolute Level (dBm)	Limit (dBm)	Margin (dB)
			Substituted Level (dBm)	Antenna Gain (dBd/dBi)	Cable Loss (dB)			
FM, Frequency: 155.7525MHz-12.5 kHz								
311.51	H	37.98	-45.78	0.00	0.32	-46.10	-20.00	26.10
311.51	V	35.94	-46.27	0.00	0.32	-46.59	-20.00	26.59
467.26	H	32.54	-48.16	0.00	0.36	-48.52	-20.00	28.52
467.26	V	31.12	-47.15	0.00	0.36	-47.51	-20.00	27.51
623.01	H	30.60	-46.48	0.00	0.36	-46.84	-20.00	26.84
623.01	V	29.12	-46.29	0.00	0.36	-46.65	-20.00	26.65
778.76	H	33.25	-41.81	0.00	0.47	-42.28	-20.00	22.28
778.76	V	31.07	-41.14	0.00	0.47	-41.61	-20.00	21.61
934.52	H	32.71	-39.63	0.00	0.51	-40.14	-20.00	20.14
934.52	V	30.86	-38.29	0.00	0.51	-38.80	-20.00	18.80
1090.27	H	36.47	-67.37	7.45	0.99	-60.91	-20.00	40.91
1090.27	V	36.85	-67.41	7.45	0.99	-60.95	-20.00	40.95
1246.02	H	37.64	-65.72	7.76	1.14	-59.10	-20.00	39.10
1246.02	V	37.56	-66.81	7.76	1.14	-60.19	-20.00	40.19
1401.77	H	41.59	-61.83	9.01	1.20	-54.02	-20.00	34.02
1401.77	V	45.68	-58.33	9.01	1.20	-50.52	-20.00	30.52
1557.53	H	37.26	-67.47	9.85	0.96	-58.58	-20.00	38.58
1557.53	V	37.68	-67.44	9.85	0.96	-58.55	-20.00	38.55
4FSK, Frequency:155.7525MHz-12.5 kHz								
311.51	H	38.89	-44.87	0.00	0.32	-45.19	-20.00	25.19
311.51	V	38.20	-44.01	0.00	0.32	-44.33	-20.00	24.33
467.26	H	39.65	-41.05	0.00	0.36	-41.41	-20.00	21.41
467.26	V	38.64	-39.63	0.00	0.36	-39.99	-20.00	19.99
623.01	H	38.27	-38.81	0.00	0.36	-39.17	-20.00	19.17
623.01	V	38.05	-37.36	0.00	0.36	-37.72	-20.00	17.72
778.76	H	38.38	-36.68	0.00	0.47	-37.15	-20.00	17.15
778.76	V	38.40	-33.81	0.00	0.47	-34.28	-20.00	14.28
934.52	H	39.60	-32.74	0.00	0.51	-33.25	-20.00	13.25
934.52	V	38.79	-30.36	0.00	0.51	-30.87	-20.00	10.87
1090.27	H	37.89	-65.95	7.45	0.99	-59.49	-20.00	39.49
1090.27	V	37.82	-66.44	7.45	0.99	-59.98	-20.00	39.98
1246.02	H	48.39	-54.97	7.76	1.14	-48.35	-20.00	28.35
1246.02	V	44.35	-60.02	7.76	1.14	-53.40	-20.00	33.40
1401.77	H	60.35	-43.07	9.01	1.20	-35.26	-20.00	15.26
1401.77	V	59.08	-44.93	9.01	1.20	-37.12	-20.00	17.12
1557.53	H	42.83	-61.90	9.85	0.96	-53.01	-20.00	33.01
1557.53	V	43.61	-61.51	9.85	0.96	-52.62	-20.00	32.62

Frequency (MHz)	Polar (H/V)	Receiver Reading (dBµV)	Substituted Method			Absolute Level (dBm)	Limit (dBm)	Margin (dB)
			Substituted Level (dBm)	Antenna Gain (dBd/dBi)	Cable Loss (dB)			
FM, Frequency: 173.9875MHz-12.5 kHz								
347.98	H	39.65	-43.55	0.00	0.34	-43.89	-20.00	23.89
347.98	V	35.60	-45.62	0.00	0.34	-45.96	-20.00	25.96
521.96	H	36.47	-42.86	0.00	0.35	-43.21	-20.00	23.21
521.96	V	33.90	-43.31	0.00	0.35	-43.66	-20.00	23.66
695.95	H	42.80	-33.28	0.00	0.38	-33.66	-20.00	13.66
695.95	V	38.60	-34.64	0.00	0.38	-35.02	-20.00	15.02
869.94	H	41.23	-32.47	0.00	0.50	-32.97	-20.00	12.97
869.94	V	38.47	-32.14	0.00	0.50	-32.64	-20.00	12.64
1043.93	H	36.78	-67.04	7.68	0.86	-60.22	-20.00	40.22
1043.93	V	37.15	-67.19	7.68	0.86	-60.37	-20.00	40.37
1217.91	H	51.69	-51.43	7.48	1.11	-45.06	-20.00	25.06
1217.91	V	49.20	-54.99	7.48	1.11	-48.62	-20.00	28.62
1391.90	H	46.13	-57.29	8.94	1.20	-49.55	-20.00	29.55
1391.90	V	48.49	-55.55	8.94	1.20	-47.81	-20.00	27.81
1565.89	H	41.86	-62.85	9.90	0.91	-53.86	-20.00	33.86
1565.89	V	46.94	-58.20	9.90	0.91	-49.21	-20.00	29.21
1739.88	H	37.06	-66.86	10.92	0.72	-56.66	-20.00	36.66
1739.88	V	36.63	-67.89	10.92	0.72	-57.69	-20.00	37.69
4FSK, Frequency:173.9875MHz-12.5 kHz								
347.98	H	39.48	-43.72	0.00	0.34	-44.06	-20.00	24.06
347.98	V	35.80	-45.42	0.00	0.34	-45.76	-20.00	25.76
521.96	H	40.92	-38.41	0.00	0.35	-38.76	-20.00	18.76
521.96	V	38.60	-38.61	0.00	0.35	-38.96	-20.00	18.96
695.95	H	37.20	-38.88	0.00	0.38	-39.26	-20.00	19.26
695.95	V	35.06	-38.18	0.00	0.38	-38.56	-20.00	18.56
869.94	H	39.64	-34.06	0.00	0.50	-34.56	-20.00	14.56
869.94	V	38.20	-32.41	0.00	0.50	-32.91	-20.00	12.91
1043.93	H	37.38	-66.45	7.68	0.86	-59.63	-20.00	39.63
1043.93	V	37.36	-66.98	7.68	0.86	-60.16	-20.00	40.16
1217.91	H	53.15	-49.97	7.48	1.11	-43.60	-20.00	23.60
1217.91	V	49.99	-54.20	7.48	1.11	-47.83	-20.00	27.83
1391.90	H	47.20	-56.22	8.94	1.20	-48.48	-20.00	28.48
1391.90	V	49.11	-54.93	8.94	1.20	-47.19	-20.00	27.19
1565.89	H	42.93	-61.78	9.90	0.91	-52.79	-20.00	32.79
1565.89	V	39.76	-65.38	9.90	0.91	-56.39	-20.00	36.39
1739.88	H	36.34	-67.58	10.92	0.72	-57.38	-20.00	37.38
1739.88	V	36.57	-67.95	10.92	0.72	-57.75	-20.00	37.75

Part 80

Frequency (MHz)	Polar (H/V)	Receiver Reading (dB μ V)	Substituted Method			Absolute Level (dBm)	Limit (dBm)	Margin (dB)
			Substituted Level (dBm)	Antenna Gain (dBd/dBi)	Cable Loss (dB)			
FM, Frequency: 154.0125MHz-25 kHz								
308.03	H	39.75	-44.06	0.00	0.32	-44.38	-13.00	31.38
308.03	V	36.80	-45.50	0.00	0.32	-45.82	-13.00	32.82
462.04	H	42.95	-37.88	0.00	0.36	-38.24	-13.00	25.24
462.04	V	40.10	-38.29	0.00	0.36	-38.65	-13.00	25.65
616.05	H	44.90	-32.28	0.00	0.36	-32.64	-13.00	19.64
616.05	V	38.00	-37.62	0.00	0.36	-37.98	-13.00	24.98
770.06	H	40.77	-34.40	0.00	0.46	-34.86	-13.00	21.86
770.06	V	39.60	-32.71	0.00	0.46	-33.17	-13.00	20.17
924.08	H	42.31	-30.30	0.00	0.51	-30.81	-13.00	17.81
924.08	V	40.00	-29.41	0.00	0.51	-29.92	-13.00	16.92
1078.09	H	38.73	-65.11	7.51	0.96	-58.56	-13.00	45.56
1078.09	V	38.26	-66.02	7.51	0.96	-59.47	-13.00	46.47
1232.10	H	37.62	-65.62	7.62	1.12	-59.12	-13.00	46.12
1232.10	V	37.42	-66.86	7.62	1.12	-60.36	-13.00	47.36
1386.11	H	40.25	-63.20	8.90	1.20	-55.50	-13.00	42.50
1386.11	V	41.32	-62.77	8.90	1.20	-55.07	-13.00	42.07
1540.13	H	41.25	-63.52	9.74	1.08	-54.86	-13.00	41.86
1540.13	V	40.58	-64.49	9.74	1.08	-55.83	-13.00	42.83

Part 74

Frequency (MHz)	Polar (H/V)	Receiver Reading (dBµV)	Substituted Method			Absolute Level (dBm)	Limit (dBm)	Margin (dB)
			Substituted Level (dBm)	Antenna Gain (dBd/dBi)	Cable Loss (dB)			
FM, Frequency: 161.1MHz-12.5 kHz								
322.20	H	43.26	-40.33	0.00	0.33	-40.66	-20.00	20.66
322.20	V	40.50	-41.42	0.00	0.33	-41.75	-20.00	21.75
483.30	H	39.60	-40.69	0.00	0.36	-41.05	-20.00	21.05
483.30	V	37.58	-40.32	0.00	0.36	-40.68	-20.00	20.68
644.40	H	41.53	-35.26	0.00	0.37	-35.63	-20.00	15.63
644.40	V	39.61	-35.17	0.00	0.37	-35.54	-20.00	15.54
805.50	H	43.95	-30.76	0.00	0.49	-31.25	-20.00	11.25
805.50	V	42.40	-29.46	0.00	0.49	-29.95	-20.00	9.95
966.60	H	45.84	-25.67	0.00	0.51	-26.18	-20.00	6.18
966.60	V	39.60	-28.74	0.00	0.51	-29.25	-20.00	9.25
1127.70	H	37.85	-65.75	7.37	1.04	-59.42	-20.00	39.42
1127.70	V	37.64	-66.56	7.37	1.04	-60.23	-20.00	40.23
1288.80	H	40.28	-63.43	8.19	1.18	-56.42	-20.00	36.42
1288.80	V	40.95	-63.68	8.19	1.18	-56.67	-20.00	36.67
1449.90	H	50.79	-53.33	9.25	1.27	-45.35	-20.00	25.35
1449.90	V	52.48	-51.99	9.25	1.27	-44.01	-20.00	24.01
1611.00	H	39.35	-65.18	10.18	0.69	-55.69	-20.00	35.69
1611.00	V	39.62	-65.51	10.18	0.69	-56.02	-20.00	36.02
FM, Frequency: 161.1MHz-25 kHz								
322.20	H	39.64	-43.95	0.00	0.33	-44.28	-13.00	31.28
322.20	V	38.54	-43.38	0.00	0.33	-43.71	-13.00	30.71
483.30	H	43.25	-37.04	0.00	0.36	-37.40	-13.00	24.40
483.30	V	41.87	-36.03	0.00	0.36	-36.39	-13.00	23.39
644.40	H	40.25	-36.54	0.00	0.37	-36.91	-13.00	23.91
644.40	V	38.20	-36.58	0.00	0.37	-36.95	-13.00	23.95
805.50	H	39.90	-34.81	0.00	0.49	-35.30	-13.00	22.30
805.50	V	39.54	-32.32	0.00	0.49	-32.81	-13.00	19.81
966.60	H	44.50	-27.01	0.00	0.51	-27.52	-13.00	14.52
966.60	V	41.23	-27.11	0.00	0.51	-27.62	-13.00	14.62
1127.70	H	38.16	-65.44	7.37	1.04	-59.11	-13.00	46.11
1127.70	V	38.65	-65.55	7.37	1.04	-59.22	-13.00	46.22
1288.80	H	43.26	-60.45	8.19	1.18	-53.44	-13.00	40.44
1288.80	V	40.66	-63.97	8.19	1.18	-56.96	-13.00	43.96
1449.90	H	45.82	-58.30	9.25	1.27	-50.32	-13.00	37.32
1449.90	V	55.36	-49.11	9.25	1.27	-41.13	-13.00	28.13
1611.00	H	38.62	-65.91	10.18	0.69	-56.42	-13.00	43.42
1611.00	V	38.93	-66.20	10.18	0.69	-56.71	-13.00	43.71

Frequency (MHz)	Polar (H/V)	Receiver Reading (dBµV)	Substituted Method			Absolute Level (dBm)	Limit (dBm)	Margin (dB)
			Substituted Level (dBm)	Antenna Gain (dBd/dBi)	Cable Loss (dB)			
4FSK, Frequency: 161.1MHz-12.5 kHz								
322.20	H	46.25	-37.34	0.00	0.33	-37.67	-20.00	17.67
322.20	V	44.70	-37.22	0.00	0.33	-37.55	-20.00	17.55
483.30	H	45.21	-35.08	0.00	0.36	-35.44	-20.00	15.44
483.30	V	40.23	-37.67	0.00	0.36	-38.03	-20.00	18.03
644.40	H	42.95	-33.84	0.00	0.37	-34.21	-20.00	14.21
644.40	V	41.30	-33.48	0.00	0.37	-33.85	-20.00	13.85
805.50	H	40.23	-34.48	0.00	0.49	-34.97	-20.00	14.97
805.50	V	38.80	-33.06	0.00	0.49	-33.55	-20.00	13.55
966.60	H	43.69	-27.82	0.00	0.51	-28.33	-20.00	8.33
966.60	V	42.00	-26.34	0.00	0.51	-26.85	-20.00	6.85
1127.70	H	40.26	-63.34	7.37	1.04	-57.01	-20.00	37.01
1127.70	V	37.64	-66.56	7.37	1.04	-60.23	-20.00	40.23
1288.80	H	40.75	-62.96	8.19	1.18	-55.95	-20.00	35.95
1288.80	V	38.31	-66.32	8.19	1.18	-59.31	-20.00	39.31
1449.90	H	55.62	-48.50	9.25	1.27	-40.52	-20.00	20.52
1449.90	V	51.52	-52.95	9.25	1.27	-44.97	-20.00	24.97
1611.00	H	42.31	-62.22	10.18	0.69	-52.73	-20.00	32.73
1611.00	V	46.21	-58.92	10.18	0.69	-49.43	-20.00	29.43

Part 22

Frequency (MHz)	Polar (H/V)	Receiver Reading (dBµV)	Substituted Method			Absolute Level (dBm)	Limit (dBm)	Margin (dB)
			Substituted Level (dBm)	Antenna Gain (dBd/dBi)	Cable Loss (dB)			
FM, Frequency: 150.8125MHz-12.5 kHz								
301.63	H	40.70	-43.21	0.00	0.31	-43.52	-13.00	30.52
301.63	V	39.56	-42.92	0.00	0.31	-43.23	-13.00	30.23
452.44	H	41.23	-39.85	0.00	0.36	-40.21	-13.00	27.21
452.44	V	38.50	-40.10	0.00	0.36	-40.46	-13.00	27.46
603.25	H	41.11	-36.25	0.00	0.36	-36.61	-13.00	23.61
603.25	V	41.02	-34.98	0.00	0.36	-35.34	-13.00	22.34
754.06	H	46.25	-29.11	0.00	0.44	-29.55	-13.00	16.55
754.06	V	42.00	-30.50	0.00	0.44	-30.94	-13.00	17.94
904.88	H	44.02	-29.08	0.00	0.51	-29.59	-13.00	16.59
904.88	V	41.90	-28.00	0.00	0.51	-28.51	-13.00	15.51
1055.69	H	38.64	-65.19	7.62	0.90	-58.47	-13.00	45.47
1055.69	V	38.25	-66.07	7.62	0.90	-59.35	-13.00	46.35
1206.50	H	38.46	-64.57	7.37	1.10	-58.30	-13.00	45.30
1206.50	V	39.64	-64.48	7.37	1.10	-58.21	-13.00	45.21
1357.31	H	44.22	-59.35	8.70	1.20	-51.85	-13.00	38.85
1357.31	V	44.76	-59.53	8.70	1.20	-52.03	-13.00	39.03
1508.13	H	44.25	-60.58	9.55	1.30	-52.33	-13.00	39.33
1508.13	V	48.95	-56.02	9.55	1.30	-47.77	-13.00	34.77
FM, Frequency: 150.8125MHz-25 kHz								
301.63	H	42.18	-41.73	0.00	0.31	-42.04	-13.00	29.04
301.63	V	39.98	-42.50	0.00	0.31	-42.81	-13.00	29.81
452.44	H	45.20	-35.88	0.00	0.36	-36.24	-13.00	23.24
452.44	V	39.11	-39.49	0.00	0.36	-39.85	-13.00	26.85
603.25	H	44.12	-33.24	0.00	0.36	-33.60	-13.00	20.60
603.25	V	43.20	-32.80	0.00	0.36	-33.16	-13.00	20.16
754.06	H	45.58	-29.78	0.00	0.44	-30.22	-13.00	17.22
754.06	V	40.21	-32.29	0.00	0.44	-32.73	-13.00	19.73
904.88	H	43.32	-29.78	0.00	0.51	-30.29	-13.00	17.29
904.88	V	42.25	-27.65	0.00	0.51	-28.16	-13.00	15.16
1055.69	H	38.63	-65.20	7.62	0.90	-58.48	-13.00	45.48
1055.69	V	38.26	-66.06	7.62	0.90	-59.34	-13.00	46.34
1206.50	H	41.23	-61.80	7.37	1.10	-55.53	-13.00	42.53
1206.50	V	43.25	-60.87	7.37	1.10	-54.60	-13.00	41.60
1357.31	H	42.24	-61.33	8.70	1.20	-53.83	-13.00	40.83
1357.31	V	43.57	-60.72	8.70	1.20	-53.22	-13.00	40.22
1508.13	H	53.75	-51.08	9.55	1.30	-42.83	-13.00	29.83
1508.13	V	50.31	-54.66	9.55	1.30	-46.41	-13.00	33.41

Frequency (MHz)	Polar (H/V)	Receiver Reading (dB μ V)	Substituted Method			Absolute Level (dBm)	Limit (dBm)	Margin (dB)
			Substituted Level (dBm)	Antenna Gain (dBd/dBi)	Cable Loss (dB)			
4FSK, Frequency: 150.8125MHz-12.5 kHz								
301.63	H	45.26	-38.65	0.00	0.31	-38.96	-13.00	25.96
301.63	V	43.95	-38.53	0.00	0.31	-38.84	-13.00	25.84
452.44	H	40.80	-40.28	0.00	0.36	-40.64	-13.00	27.64
452.44	V	39.48	-39.12	0.00	0.36	-39.48	-13.00	26.48
603.25	H	45.15	-32.21	0.00	0.36	-32.57	-13.00	19.57
603.25	V	43.80	-32.20	0.00	0.36	-32.56	-13.00	19.56
754.06	H	40.28	-35.08	0.00	0.44	-35.52	-13.00	22.52
754.06	V	39.21	-33.29	0.00	0.44	-33.73	-13.00	20.73
904.88	H	40.50	-32.60	0.00	0.51	-33.11	-13.00	20.11
904.88	V	40.10	-29.80	0.00	0.51	-30.31	-13.00	17.31
1055.69	H	38.26	-65.57	7.62	0.90	-58.85	-13.00	45.85
1055.69	V	38.46	-65.86	7.62	0.90	-59.14	-13.00	46.14
1206.50	H	48.35	-54.68	7.37	1.10	-48.41	-13.00	35.41
1206.50	V	46.31	-57.81	7.37	1.10	-51.54	-13.00	38.54
1357.31	H	56.42	-47.15	8.70	1.20	-39.65	-13.00	26.65
1357.31	V	54.29	-50.00	8.70	1.20	-42.50	-13.00	29.50
1508.13	H	60.35	-44.48	9.55	1.30	-36.23	-13.00	23.23
1508.13	V	57.41	-47.56	9.55	1.30	-39.31	-13.00	26.31

Note 1: The unit of antenna gain is dBd for frequency below 1GHz and is dBi for frequency above 1GHz.

Note 2:

Absolute Level = Substituted Level - Cable loss + Antenna Gain

Margin = Limit - Absolute Level

7 - FREQUENCY STABILITY

Applicable Standard

FCC §2.1055, § 22.355, §74.464, §80.209 and §90.213

Test Procedure

Frequency Stability vs. Temperature: The equipment under test was connected to an external DC power supply and the RF output was connected to a frequency counter via feed-through attenuators. The EUT was placed inside the temperature chamber. The DC leads and RF output cable exited the chamber through an opening made for the purpose.

After the temperature stabilized for approximately 20 minutes, the frequency output was recorded from the counter.

Test Data

Test Mode: Transmitting

Test Result: Compliance. *Please refer to following tables.*

FCC Part 90:

FM,12.5kHz, Reference Frequency: 155.7525 MHz, Limit: ±5.0 ppm			
Temperature (°C)	Voltage Supplied (V _{DC})	Measured Frequency (MHz)	Frequency Error (ppm)
-30	13.6	155.7526063	0.68
-20		155.7525731	0.47
-10		155.7525748	0.48
0		155.7525698	0.45
10		155.7526346	0.86
20		155.7525800	0.51
30		155.7525258	0.17
40		155.7526853	1.19
50		155.7525546	0.35
20		10.8	155.7525172
20	15.6	155.7525800	0.51

4FSK, 12.5kHz, Reference Frequency: 155.7525MHz, Limit: ±5.0 ppm			
Temperature (°C)	Voltage Supplied (V _{DC})	Measured Frequency (MHz)	Frequency Error (ppm)
-30	13.6	155.7526463	0.94
-20		155.7525272	0.17
-10		155.7525096	0.06
0		155.7525727	0.47
10		155.7526393	0.89
20		155.7525360	0.23
30		155.7525367	0.24
40		155.7525988	0.63
50		155.7525145	0.09
20		10.8	155.7525737
20	15.6	155.7525772	0.50

FCC Part 80:

FM,25kHz, Reference Frequency: 154.0125MHz,Limit: ±5.0 ppm			
Temperature (°C)	Voltage Supplied (V_{DC})	Measured Frequency (MHz)	Frequency Error (ppm)
-30	13.6	154.012663	1.06
-20		154.012521	0.13
-10		154.012611	0.72
0		154.012650	0.98
10		154.012620	0.78
20		154.012558	0.38
30		154.012671	1.11
40		154.012660	1.04
50		154.012578	0.51
20		10.8	154.012622
20	15.6	154.012671	1.11

FCC Part 74:

FM, 12.5kHz, Reference Frequency: 161.1 MHz, Limit: ±5.0 ppm			
Temperature (°C)	Voltage Supplied (V_{DC})	Measured Frequency (MHz)	Frequency Error (ppm)
-30	13.6	161.1000264	0.16
-20		161.1001809	1.12
-10		161.1001788	1.11
0		161.1001211	0.75
10		161.1000762	0.47
20		161.1000580	0.36
30		161.1001681	1.04
40		161.1001499	0.93
50		161.1000123	0.08
20		10.8	161.1000319
20	15.6	161.1001303	0.81

4FSK, 12.5kHz, Reference Frequency: 161.1 MHz, Limit: ±5.0 ppm			
Temperature (°C)	Voltage Supplied (V_{DC})	Measured Frequency (MHz)	Frequency Error (ppm)
-30	13.6	161.1000168	0.10
-20		161.1000004	0.00
-10		161.1001683	1.04
0		161.1001314	0.82
10		161.1001599	0.99
20		161.1001810	1.12
30		161.1001766	1.10
40		161.1000932	0.58
50		161.1000606	0.38
20		10.8	161.1001130
20	15.6	161.1001024	0.64

FM, 25kHz, Reference Frequency: 161.1 MHz, Limit: ±5.0 ppm			
Temperature (°C)	Voltage Supplied (V_{DC})	Measured Frequency (MHz)	Frequency Error (ppm)
-30	13.6	161.1001505	0.93
-20		161.1001372	0.85
-10		161.1000608	0.38
0		161.1000308	0.19
10		161.1000288	0.18
20		161.1000580	0.36
30		161.1001692	1.05
40		161.1001634	1.01
50		161.1000873	0.54
20		10.8	161.1000443
20	15.6	161.1001991	1.24

FCC Part 22:

FM, 12.5kHz, Reference Frequency: 150.8125MHz, Limit: ±5.0 ppm			
Temperature (°C)	Voltage Supplied (V_{DC})	Measured Frequency (MHz)	Frequency Error (ppm)
-30	13.6	150.8125428	0.28
-20		150.8126323	0.88
-10		150.8125937	0.62
0		150.8126990	1.32
10		150.8126428	0.95
20		150.8125580	0.38
30		150.8125645	0.43
40		150.8125899	0.60
50		150.8125190	0.13
20		10.8	150.8125759
20	15.6	150.8126381	0.92

4FSK, 12.5kHz, Reference Frequency: 150.8125MHz, Limit: ±5.0 ppm			
Temperature (°C)	Voltage Supplied (V_{DC})	Measured Frequency (MHz)	Frequency Error (ppm)
-30	13.6	150.8125104	0.07
-20		150.8125956	0.63
-10		150.8125351	0.23
0		150.8125935	0.62
10		150.8125869	0.58
20		150.8125725	0.48
30		150.8125504	0.33
40		150.8126558	1.03
50		150.8125558	0.37
20		10.8	150.8125090
20	15.6	150.8126102	0.73

FM, 25kHz, Reference Frequency: 150.8125MHz, Limit: ±5.0 ppm			
Temperature (°C)	Voltage Supplied (V_{DC})	Measured Frequency (MHz)	Frequency Error (ppm)
-30	13.6	150.8126684	1.12
-20		150.8125006	0.00
-10		150.8126337	0.89
0		150.8126663	1.10
10		150.8125430	0.29
20		150.8125580	0.38
30		150.8126499	0.99
40		150.8126096	0.73
50		150.8125244	0.16
20		10.8	150.8126675
20	15.6	150.8125605	0.40

8 - TRANSIENT FREQUENCY BEHAVIOR

Applicable Standard

Regulations: FCC §90.214

Test Procedure

- a) Connect the EUT and test equipment as shown on the following block diagram.
- b) Set the Spectrum Analyzer to measure FM deviation, and tune the RF frequency to the transmitter assigned frequency.
- c) Set the signal generator to the assigned transmitter frequency and modulate it with a 1 kHz tone at ± 12.5 kHz deviation and set its output level to -100dBm.
- d) Turn on the transmitter.
- e) Supply sufficient attenuation via the RF attenuator to provide an input level to the Spectrum Analyzer that is 40 dB below the maximum allowed input power when the transmitter is operating at its rated power level. Note this power level on the Spectrum Analyzer as P_0 .
- f) Turn off the transmitter.
- g) Adjust the RF level of the signal generator to provide RF power equal to P_0 . This signal generator RF level shall be maintained throughout the rest of the measurement.
- h) Remove the attenuation 1, so the input power to the Spectrum Analyzer is increased by 30 dB when the transmitter is turned on.
- i) Adjust the vertical amplitude control of the spectrum analyzer to display the 1000 Hz at ± 4 divisions vertically centered on the display. Set trigger mode of the Spectrum Analyzer to "Video", and tune the "trigger level" on suitable level. Then set the "trigger offset" to -10ms for turn on and -15ms for turn off.
- j) Turn on the transmitter and the transient wave will be captured on the screen of Spectrum Analyzer. Observe the stored display. The instant when the 1 kHz test signal is completely suppressed is considered to be t_{on} . The trace should be maintained within the allowed divisions during the period t_1 and t_2 .
- k) Then turn off the transmitter, and another transient wave will be captured on the screen of Spectrum Analyzer. The trace should be maintained within the allowed divisions during the period t_3 .

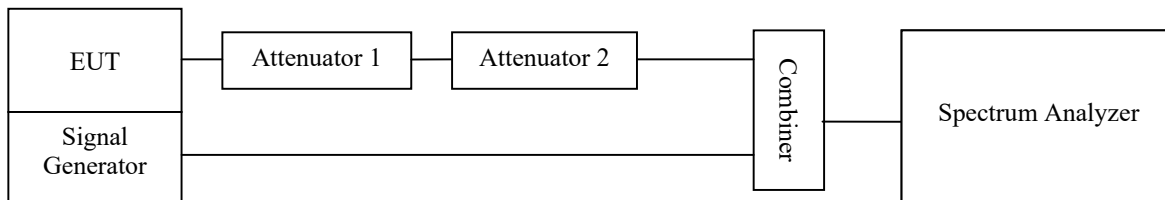

Test Data

Test Mode: Transmitting

Test Result: Compliance. Please refer to the following table and plots.

Channel Spacing (kHz)	Transient Period (ms)	Transient Frequency	Result
12.5	5(t ₁)	±12.5 kHz	Pass
	20(t ₂)	±6.25 kHz	
	5(t ₃)	±12.5 kHz	

155.7525_Turn On

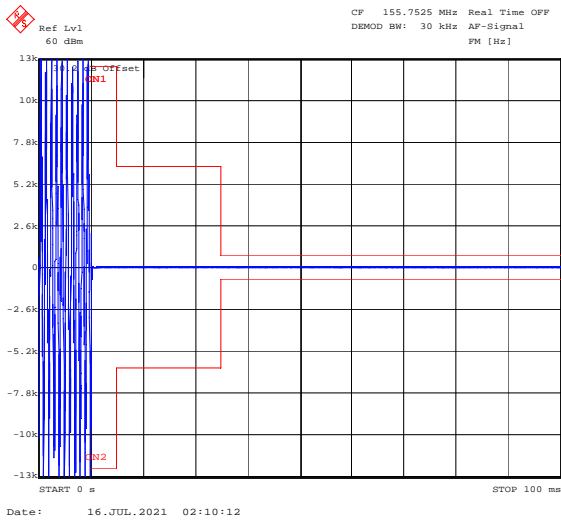

155.7525_Turn Off

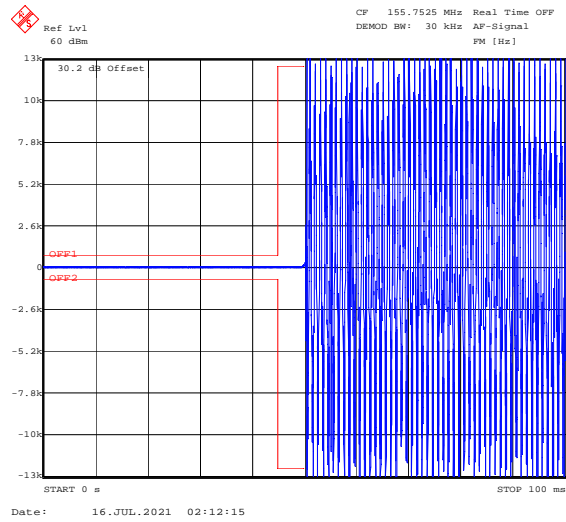

******* END OF REPORT *******