

User Manual

Digital WANET Repeater

Preface

Thanks for your favor in our product. This manual provides guidance for you to use the product. To avoid bodily injury and property loss caused by improper operations, please read the Safety Information Booklet before using the product.

This manual is applicable to the following product:

E-pole Digital WANET Repeater

Icon Conventions

The following icons are available through this manual:



Caution: indicates situations that could cause damage to your product.



Note: indicates tips that can help you make better use of your product.

Copyright Information

Hytera is the trademark or registered trademark of Hytera Communications Corporation Limited (the Company) in PRC and/or other countries or areas. The Company retains the ownership of its trademarks and product names. All other trademarks and/or product names that may be used in this manual are properties of their respective owners.

The product described in this manual may include the Company's computer programs stored in memory or other media. Laws in PRC and/or other countries or areas protect the exclusive rights of the Company with respect to its computer programs. The purchase of this product shall not be deemed to grant, either directly or by implication, any rights to the purchaser regarding the Company's computer programs. Any of the Company's computer programs may not be copied, modified, distributed, decompiled, or reverse-engineered in any manner without the prior written consent of the Company.

Disclaimer

The Company endeavors to achieve the accuracy and completeness of this manual, but no warranty of accuracy or reliability is given. All the specifications and designs are subject to change without notice due to continuous technology development. No part of this manual may be copied, modified, translated, or distributed in any manner without the prior written consent of the Company.

We do not guarantee, for any particular purpose, the accuracy, validity, timeliness, legitimacy or completeness of the Third Party products and contents involved in this manual.

If you have any suggestions or would like to learn more details, please visit our website at: <http://www.hytera.com>.

FCC Regulations

Federal Communication Commission (FCC) requires that all radio communication products should meet the requirements set forth in the above standards before they can be marketed in the U.S, and the manufacturer shall post a RF label on the product to inform users of operational instructions, so as to enhance their occupational health against exposure to RF energy.

FCC Statement

This equipment has been tested and found to comply with the limits for a Class B digital device, pursuant to part 15 of FCC Rules. These limits are designed to provide reasonable protection against harmful interference in a residential installation. This equipment generates and can radiate radio frequency energy. If not installed and used in accordance with the instructions, it may cause harmful interference to radio communications. However, there is no guarantee that interference will not occur in a particular installation. Verification of harmful interference by this equipment to radio or television reception can be determined by turning it off and then on. The user is encouraged to try to correct the interference by one or more of the following measures:

- Reorient or relocate the receiving antenna. Increase the separation between the equipment and receiver.
- Connect the equipment into an outlet on a different circuit to that of the receiver's outlet.
- Consult the dealer or an experienced radio/TV technician for help.

Operation is subject to the following two conditions:

- This device may not cause harmful interference.
- This device must accept any interference received, including interference that may cause undesired operation.

Note: Changes or modifications to this unit not expressly approved by the party responsible for compliance could void the user's authority to operate the equipment.

Operational Instructions and Training Guidelines

To ensure optimal performance and compliance with the occupational/controlled environment RF energy exposure limits in the above standards and guidelines, users should transmit not more than 50% of the time and always adhere to the following procedures:

- Antenna gain must not exceed 3.2dBi for DMR and 1.0dBi for GSM850 and 3.5 for PCS1900.
- The antenna must be installed complying with the requirements of manufacturer or supplier, and it must be at least 0.5 meters away from human body.

Compliance with RF Exposure Standards

Hytera's radio complies with the following RF energy exposure standards and guidelines:

- United States Federal Communications Commission, Code of Federal Regulations; 47 CFR § 1.1307, 1.1310 and 2.1091
 - American National Standards Institute (ANSI) / Institute of Electrical and Electronic Engineers (IEEE) C95. 1:2005; Canada RSS102 Issue 5 March 2015

ISED Statement

This device complies with Innovation, Science and Economic Development Canada Compliance license-exempt RSS standard(s). Operation is subject to the following two conditions:

- This device may not cause harmful interference.
- This device must accept any interference received, including interference that may cause undesired operation.

Le présent appareil est conforme aux CNR d'Industrie Canada applicables aux appareils radio exempts de licence. L'exploitation est autorisée aux deux conditions suivantes: (1) l'appareil ne doit pas produire de brouillage, et (2) l'utilisateur de l'appareil doit accepter tout brouillage radioélectrique subi, même si le brouillage est susceptible d'en compromettre le fonctionnement.

ISED Radiation Exposure Statement:

This device must be restricted to work related operations in an Occupational/Controlled RF exposure Environment.

This equipment should be installed and operated with minimum distance 50cm between the antenna & your body.

ISED exposition aux radiations:

Ce dispositif doit être limité aux opérations liées au travail dans un environnement d'exposition RF professionnel/contrôlé.

Cet équipement doit être installé et utilisé avec un minimum de 50cm de distance entre le antenne et votre corps.

EU Regulatory Conformance

As certified by the qualified laboratory, the product is in compliance with the essential requirements and other relevant provisions of the Directive:

- 2014/53/EU
- 2006/66/EC
- 2011/65/EU
- 2012/19/EU

Please note that the above information is applicable to EU countries only.

The maximum antenna gain is 3.5dBi, which is calculated in the EIRP. The distance from observation point to the antenna is 60cm.

Restrict use warning:



AT	BE	CY	CZ	DK
EE	FI	FR	DE	EL
HU	IE	IT	LV	LT
LU	MT	NL	PL	PT
SK	SI	ES	SE	UK
BG	RO	HR		

Contents

1. Checking Items in the Package	1
2. Product Descriptions	2
3. Installation	4
3.1 Installation Requirements	4
3.2 Pre-Installation Tasks	5
3.3 Device Installation.....	6
3.4 Cables Installation.....	11
3.5 Post-installation Check	12
4. Basic Operations	13
4.1 Power on.....	13
4.2 Power off.....	13
5. Troubleshooting	14
6. Care and Cleaning	15
7. Optional Accessories	16
8. Scope and Duration of Warranty	17

1. Checking Items in the Package

Please unpack carefully and check if all items listed below are received. If any item is missing or damaged, please contact your dealer.

Name	Qty	Name	Qty
Mainframe	1	DC Wire	1
AC Wire	1	Owner's Manual	1



Note

All pictures in this manual are for reference only.

2. Product Descriptions

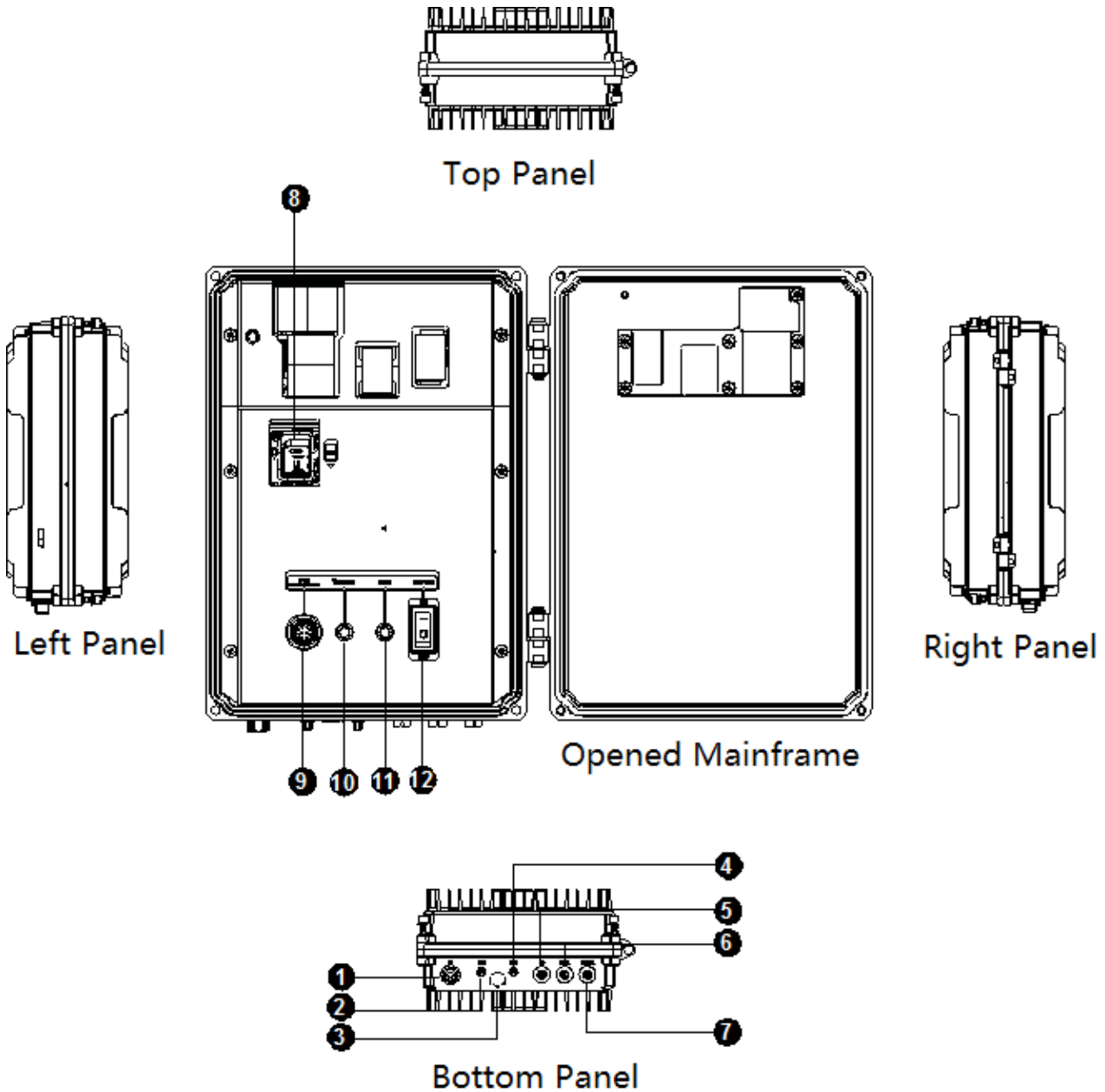

No	Part Name	Description
1	RF Antenna Interface	Used to connect RF antenna for signal transmission and reception. The interface type is the UHF interface.
2	GPS Antenna Interface	Connect GPS antenna, and used for transmit and receive SPG signal.
3	Waterproof and breathable hole	Prevent the cavity from forming a vacuum and the lid can not be opened.
4	GSM Antenna	Connect GSM antenna, public network link as a backup link.

No	Part Name	Description
	Interface	
5	Bei Dou Interface	The reserved interface is not developed for the time being.
6	Data Interface	For E-pole100 debugging. Interconnect with center via IP network.
7	Power Interface	The device applies external power supply which supplies AC 100-240V and DC 15V±10%. DC power line is connected to DC input, and AC input is connected to AC power line.
8	SIM Slot	Install SIM card, and transmit data through GSM link.
9	Speaker Interface	Connect speaker.
10	Power Indicator	Battery supply status indication. The power indicator grows red constantly after power on.
11	Operation Indicator	Indicates operation status. Under the normal operation state, the indicator glows red constantly.
12	Backup Battery Indicator	Control the opening and closing of the built-in standby battery of the mainframe, and the standby power supply provides the voltage of the 10.8V.

3. Installation

3.1 Installation Requirements

Be sure to follow procedures below for proper installation.

Local Regulations and Norms

When installing the equipment, please follow the local regulations and norms.

Battery



Danger

- Direct contact or indirect contact of high pressure and electricity through wet objects will bring danger of electric shock.
 - Unstandardized and incorrect operations may cause accidents such as fire or electric shock.
-

- It is strictly prohibited to wear conductive objects such as watches, bracelets, rings and so on
- Special tools must be used in the operation of high voltage and alternating current.
- When operating in a wet environment, water should be prevented from entering the equipment.
- When operating in thunderstorm weather, in order to avoid lightning damages equipment, the lightning protection work of the equipment should be done in time.
- The power supply must be closed before the installation and removal of the equipment.
- Before connecting the cable, the cable and the cable label must be confirmed.
- The grounding operation must be completed before the device is connected to the power supply.
- When it is found that the equipment is wet, or there is water or other liquids, please close the power immediately.
- Before installing the device, the power switch should be closed.

High Altitude Operation

Operations at more than 2 meters above the ground are all high altitude operations. At high altitude, the notices below must be followed.

- In the event of lightning, rain, snow, high winds above six levels, and dangerous conditions such as dry rain in the steel pipe, the high altitude operation should be stopped.
- At the scene of high altitude operation, the dangerous forbidden area should be drawn out, and the marked sign should be set up, and the unrelated personnel shall be strictly prohibited.
- The ground below the high altitude operation area is strictly forbidden to stack the scaffolding, the springboard and other sundries. Ground personnel are strictly forbidden to stay or pass right below the high altitude operation area.

- High altitude operators should not throw objects from high altitude to the ground, nor throw objects from the ground to the upper air. We should use strong cables, hanging baskets, elevated cars or cranes to deliver objects.
- Do a good job of safety protection, wear a helmet and fasten your seat belt correctly.
- In cold areas, the cold defensive equipment should be worn before the high altitude operation.
- Before the using a ladder, it should be confirmed that the ladder is not damaged, and can be used by inspection. It is forbidden to be overweight when used.
- Safety measures should be done in scenarios when the ladder is inclined more than 5m, vertical height of vertical double foot ladder is more than 3m and operation is in dangerous environment.
- High altitude operators should carry, use and place machinery and tools properly to prevent falling on others.
- Laughing and sleep in high altitude area is strictly prohibited in high altitude operation.

Personnel

The personnel engaged in the device operation must have basic knowledge of safety operation, and is professional trained, and have corresponding job qualifications.

3.2 Pre-Installation Tasks

3.2.1 Installation Environment

Space Requirements

- Keep at least 200mm space above.
- Keep at least 500mm space below.
- Keep at least 800mm space at right side.

Grounding Requirements

- The device must be grounded first when install the device. The ground wire must be removed at last when dismantled.
- It is forbidden to damage the grounding conductors.
- It is forbidden to operate the device where no ground wires are installed.
- The device must be grounded permanently. Before operating the device, electrical connection must be checked first to make sure that the device is grounded.

3.2.2 Tools Preparation

Before installation, please prepare the following tools as shown below.

Standard Tools	Cross screwdriver, screwdriver, movable spanner, six-angle wrench, cross torque screwdriver, dual wrench, rubber hammer, torque sleeve
Protective Tools	Antistatic wristband, seat belt, helmet, safety rope, antiskid gloves.
Cable Making Tools	Crimping pliers, stripping pliers, cutting pliers
Instrument Tool	Multimeter, tape measure, level ruler
Assistant Tools	Fixed pulley, herringbone ladder, marking pen, impact drill, insulating tape, ribbon (ultraviolet proof band), label, screw assembly, expansion screw assembly, tool knife, hot air gun, waterproof tape

3.2.3 Materials Preparation

Before installation, please open the box and check the goods in accordance with the list of equipment to ensure that the material is complete.

3.3 Device Installation

E-pole100 can adopts pole-mounted and wall-mounted type to install and user can choose according to the actual needs.



Note

The parts used in the installation process should be purchased separately. Please consult the dealer or the sales staff of our company.

3.3.1 Bracket Introduction

Bracket components includes pole-mounted bracket components and wall-mounted bracket components. The two both consists of bracket, four M3×8 bolts ② and four silicone products ①.

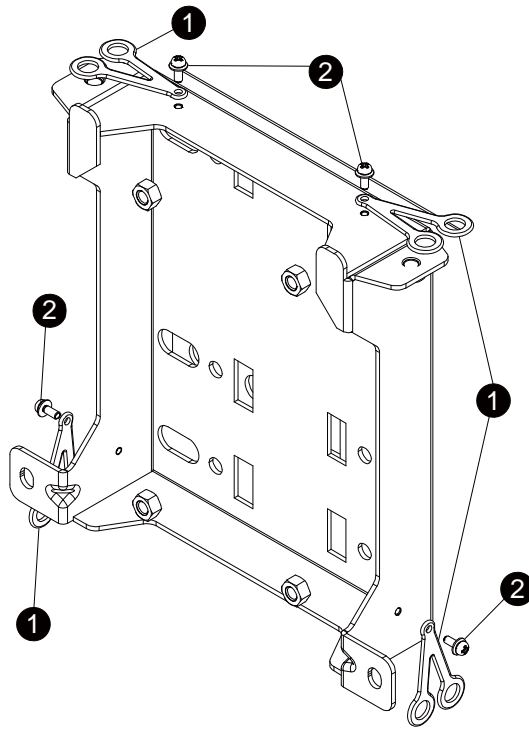

3.3.2 Pole-Mounted Installation

1. Use two M6x16 bolts to fix the bracket to the rear side of mainframe.

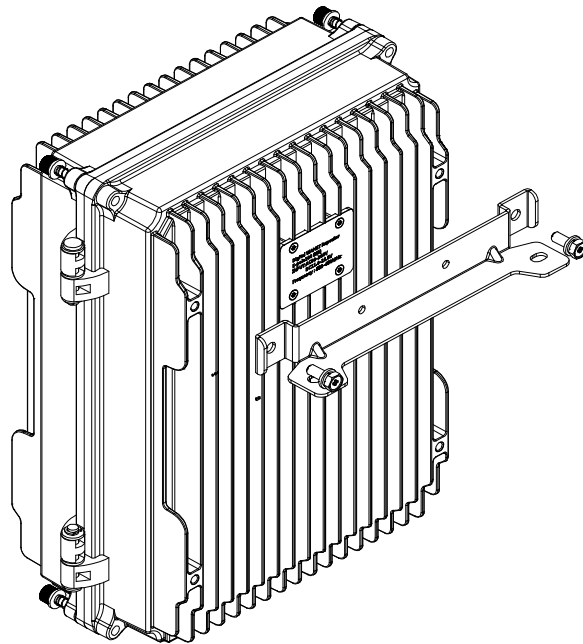

2. Use four M6x16 bolts to fix the pole-mounted bracket to the pole-mounted bracket components.

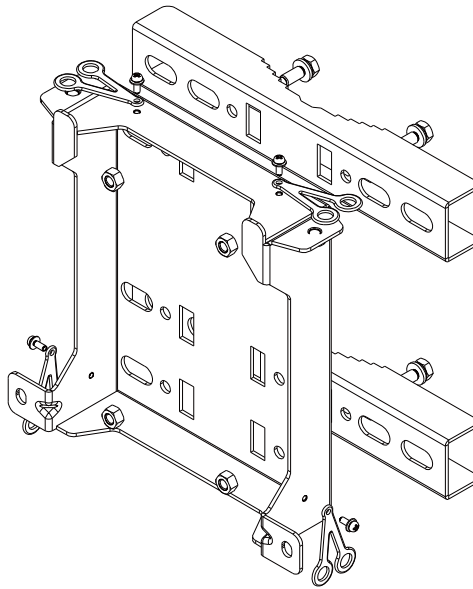

3. Mark the position of the pole-mounted bracket components on the pole.
-

 **Caution**

The diameter of the holding rod should not exceed 180mm.

4. Use four M10×240 screw suite to fix pole-mounted bracket components and pole-mounted bracket to pole.

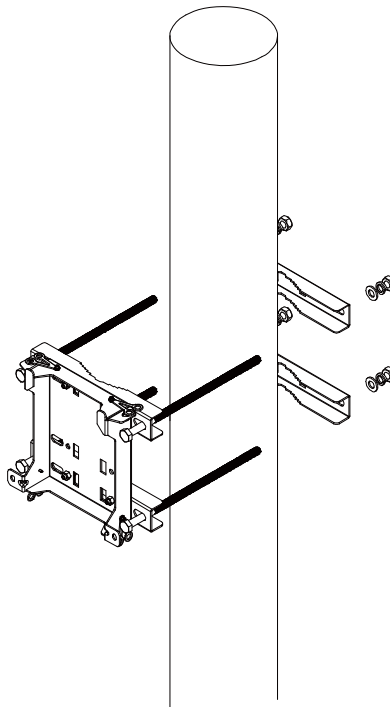

5. Adopt the same method to install antenna bracket components, GPS antenna, Bei Dou antenna and RF antenna.
-

 **Caution**

The distance between pole-mounted bracket components and antenna bracket components

can be less than 200mm.

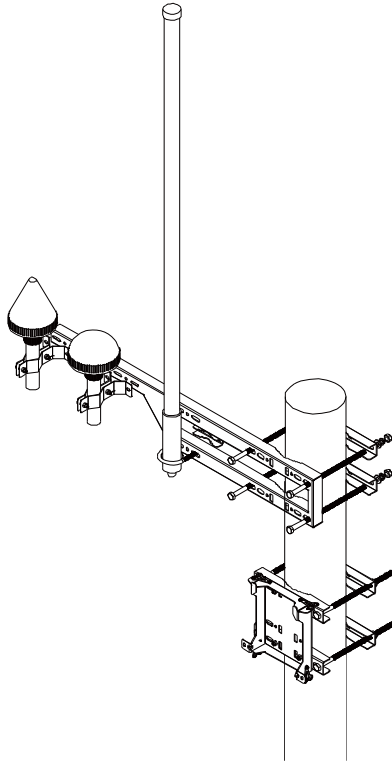

6. Fix the bracket of mainframe to pole-mounted bracket components with four M6×16 bolts ①.

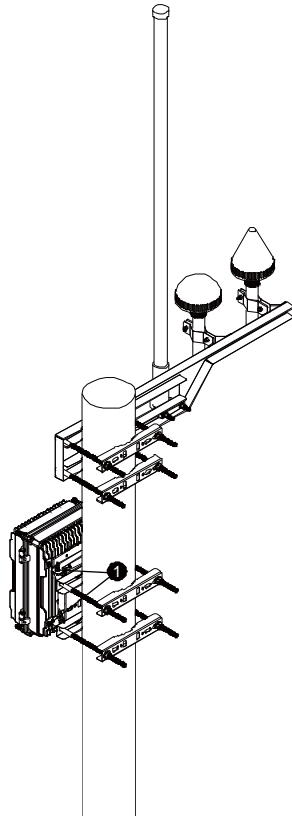

3.3.3 Wall-mounted Installation

1. Use two M6×16 bolts to fix the bracket to the rear side of the mainframe.

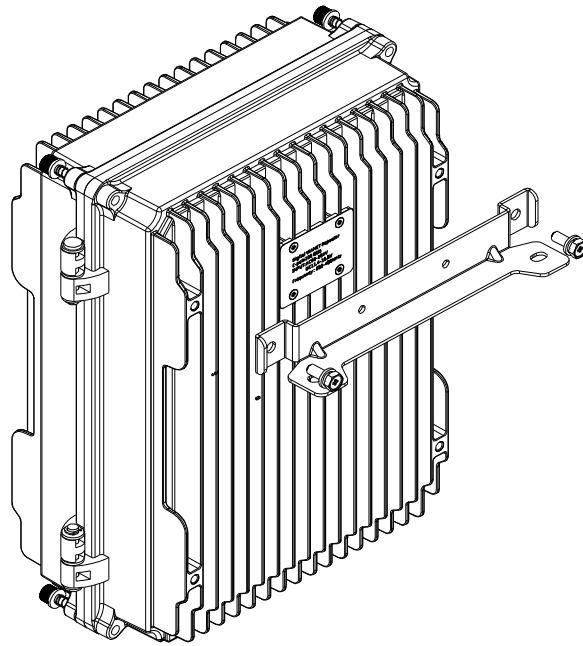

2. Keep the wall-mounted bracket closely to the wall, level the installation position with a horizontal ruler and mark the point with the marker pen.
3. Punch holes at the location and install the expansion bolt, and use the 4 M6x65 expansion screws to fix the wall-mounted bracket on the wall.
4. The distance between the horizontal and vertical directions is 80mm and 145mm, respectively.
The distance between the horizontal and vertical directions is 80mm and 145mm, respectively.

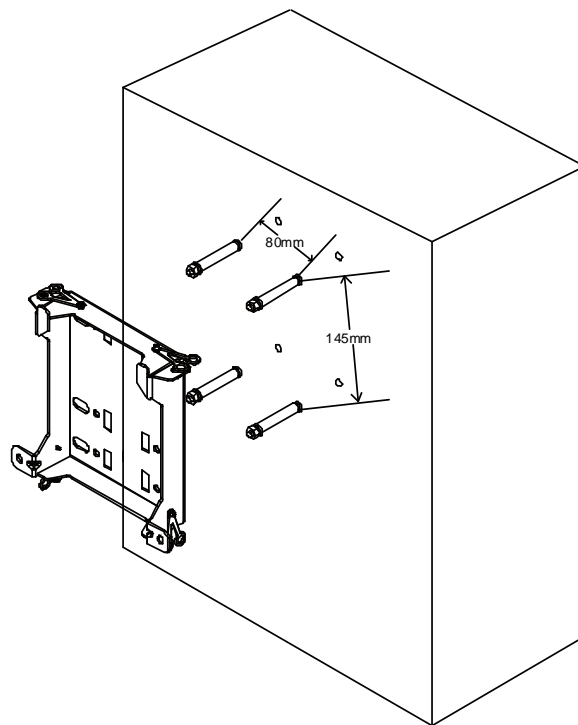

5. Fix bracket of the mainframe to the wall-mounted components, and use four M6x16 bolts ① to fix it.

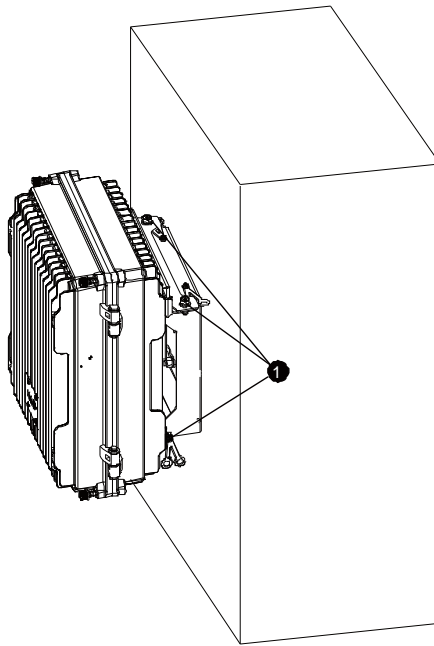

3.4 Cables Installation

3.4.1 Cable Laying Requirements

Cable placement needs to meet the required layout requirements in order to prevent inter signal interference.

Installation Requirement

- When deploy cables, try to avoid sharp object or wall burr, if impossible, and then use a liner protective cable.
- When deploy cables, try to avoid heat source, or add insulation material between the heat source.

Binding Requirements

- Similar cables should be tied up together.
- The tied up cables should be closed to each other, flat, tidy and without skin damage.
- When making the cable clasps, it should all face to the same direction. The cable in the same position should be in the same level.
- After finishing installing the cables, a label must be pasted at both cable ends, in the middle or cable bending part.
- Different types of cables are distributed separately. And intertwining or cross deployment is forbidden.

Power Cable Laying Requirements

- The position of the power line distribution should be in accordance with the requirements of the engineering design drawings.

- In the process of distribution, if the length of the power line is not enough, the power line should be replaced, and the joint or welding point should not be made with the power line.
- Playing ring, twisted cable laying phenomenon is strictly prohibited.

Protected Ground Wire Laying Requirements

- The ground wire is strictly forbidden to be introduced through air and must be buried in the whole process or in the indoor line.
- The protection of ground wire and signal line should not be tied together or intertwined, and the distance should be kept to reduce interference.
- All palpable conductive metal parts of the device must be reliably connected to the grounding terminal.

3.4.2 Wire Connection Schematic

Wire interface is at the bottom panel of the mainframe as shown below.

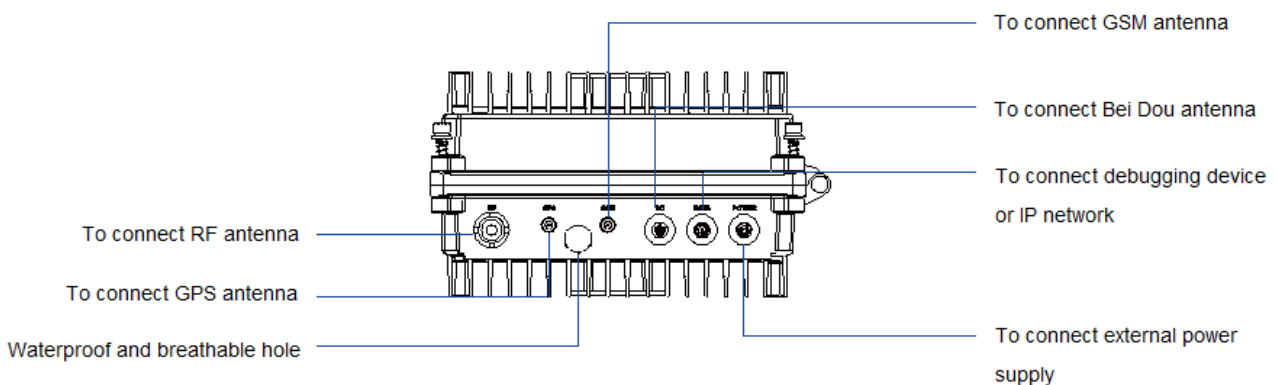

3.5 Post-installation Check

After installation, contact the device with external power supply. Check if the device operates properly through looking at LED indicator at front panel. When the device connects to power supply and operates properly, the battery indicator grows red constantly, and operating indicator grows red constantly.

4. Basic Operations

4.1 Power on

Connect the product to the external power supply, and the battery indicator glows red constantly.

 **Note**

In order to make sure that the device can operate for a short time after a sudden power failure. It is suggestible that put the built-in battery switch to **ON** position.

4.2 Power off

Disconnect the external power supply, and the battery indicator goes off. Make sure that built-in battery switches to OFF.

5. Troubleshooting

Phenomena	Analysis	Solution
The product cannot be powered on.	Abnormal connection of power cord.	Connect the power cord properly and ensure secure connection.
Communication failure between E-pole100s, and failure between E-pole100 and E-pack100.	Problems with transceiver frequency band configuration of system.	Check the frequency. Please contact dealer if necessary.
	The product encounters strong interference signal.	Check the interference signal source. If you cannot remove or bypass the interference signal source, change the frequencies.
	Other E-pole100 or E-pack100 has left the communication coverage of the E-pole100.	Confirm and come back to the communication coverage of E-pole100.
	Abnormal connection of E-pole100 antenna.	Check if antenna connection.
Short communication range or poor audio.	The connection cable is damaged to cause leakage of signal energy.	Check the cable. If necessary, replace the cable with a new one.
	The connector on the antenna cable may get loose or even disconnected.	Check and secure the connector on the antenna cable, or replace it if necessary.
	Tx Power is too low	Set Tx power to high power.
	Invisible damage may occur to the cable.	Replace the cable with a new one.
	The product encounters strong interference signal.	Check the interference signal source. If you cannot remove or bypass the interference signal source, change the frequencies.

If the above solutions cannot fix your problems, or you may have some other queries, please contact us or your local dealer for more technical support.

6. Care and Cleaning

To guarantee optimal performance as well as a long service life of the product, please follow the tips below.

Product Care

- Do not pierce or scrape the product
- Keep the product far away from substances that can corrode the circuit.
- Please keep the product dry.
- Please don't put the product somewhere too hot. High temperature will shorten the life span of electronic devices, damage battery, deform or melt some plastic parts.
- Please don't put the product somewhere too cold. When the temperature is high and above room temperature, moisture inside the device will emerge and leads to damage to circuit board.

Product Cleaning



Caution

Disconnect the power supply from the product before cleaning.

- Clean up the dust and fine particles on the product surface and charging piece with a clean and dry lint-free cloth or a brush regularly.
- Use neutral cleanser and a non-woven fabric to clean the keys and surface after long-time use. Do not use chemical preparations such as stain removers, alcohol, sprays or oil preparations, so as to avoid surface damage.
- Make sure the product is completely dry before use.

7. Optional Accessories

Contact your local dealer for the optional accessories of the product.



Caution

Use the accessories specified by the Company only; otherwise, we shall not be liable for any losses or damages arising out of use of unauthorized accessories.

8. Scope and Duration of Warranty

Our company promises that if there is any material or manufacturing process defects of the products produced by us from the date of purchase under normal use, operation and maintenance conditions, can enjoy the following provisions of warranty service.