



# FCC PART 15.247

## TEST REPORT

For

### Hytera Communications Corporation Limited

Hytera Tower, Hi-Tech Industrial Park North, 9108# Beihuan Road, Nanshan District, Shenzhen, People's Republic of China

**FCC ID: YAMECENTER**

<b>Report Type:</b> Original Report	<b>Product Type:</b> On-site Command and Dispatch Center
<b>Report Number:</b> RDG191210020-00A	
<b>Report Date:</b> 2020-12-15	
<b>Reviewed By:</b> Jimmy Xiao	<i>Jimmy Xiao</i>
<b>Reviewed By:</b> RF Engineer	
<b>Prepared By:</b> Bay Area Compliance Laboratories Corp. (Shenzhen) 6/F., West Wing, Third Phase of Wanli Industrial Building, Shihua Road, Futian Free Trade Zone, Shenzhen, Guangdong, China Tel: +86-755-33320018 Fax: +86-755-33320008 <a href="http://www.baclcorp.com.cn">www.baclcorp.com.cn</a>	

**Note:** This report may contain data that are not covered by the A2LA accreditation and are marked with an asterisk “★”.

BACL is not responsible for the authenticity of any test data provided by the applicant. Data included from the applicant that may affect test results are marked with an asterisk “\*”. Customer model name, addresses, names, trademarks etc. are not considered data.

This report cannot be reproduced except in full, without prior written approval of the Company. Unless otherwise stated the results shown in this test report refer only to the sample(s) tested. This report is valid only with a valid digital signature. The digital signature may be available only under the Adobe software above version 7.0.

## TABLE OF CONTENTS

<b>GENERAL INFORMATION.....</b>	<b>4</b>
PRODUCT DESCRIPTION FOR EQUIPMENT UNDER TEST (EUT).....	4
OBJECTIVE .....	4
TEST METHODOLOGY .....	4
MEASUREMENT UNCERTAINTY .....	5
<b>SYSTEM TEST CONFIGURATION.....</b>	<b>6</b>
DESCRIPTION OF TEST CONFIGURATION .....	6
EQUIPMENT MODIFICATIONS .....	6
EUT EXERCISE SOFTWARE .....	6
DUTY CYCLE.....	6
SUPPORT EQUIPMENT LIST AND DETAILS .....	7
EXTERNAL I/O CABLE.....	7
BLOCK DIAGRAM OF TEST SETUP .....	8
<b>SUMMARY OF TEST RESULTS .....</b>	<b>9</b>
<b>TEST EQUIPMENT LIST .....</b>	<b>10</b>
<b>FCC §15.247 (i) &amp; §2.1091- MAXIMUM PERMISSIBLE EXPOSURE (MPE).....</b>	<b>11</b>
APPLICABLE STANDARD .....	11
RESULT .....	11
<b>FCC §15.203 - ANTENNA REQUIREMENT.....</b>	<b>13</b>
APPLICABLE STANDARD .....	13
ANTENNA CONNECTOR CONSTRUCTION .....	13
<b>FCC §15.207 (a) – AC LINE CONDUCTED EMISSIONS .....</b>	<b>14</b>
APPLICABLE STANDARD .....	14
EUT SETUP.....	14
EMI TEST RECEIVER SETUP.....	14
TEST PROCEDURE .....	14
CORRECTED FACTOR & MARGIN CALCULATION .....	15
TEST DATA .....	15
<b>FCC §15.209, §15.205 &amp; §15.247(d) - SPURIOUS EMISSIONS.....</b>	<b>18</b>
APPLICABLE STANDARD .....	18
EUT SETUP.....	18
EMI TEST RECEIVER & SPECTRUM ANALYZER SETUP .....	19
TEST PROCEDURE .....	19
CORRECTED AMPLITUDE & MARGIN CALCULATION .....	19
TEST DATA .....	19
<b>FCC §15.247(a) (2) – 6 dB EMISSION BANDWIDTH.....</b>	<b>29</b>
APPLICABLE STANDARD .....	29
TEST PROCEDURE .....	29
TEST DATA .....	29
<b>FCC §15.247(b) (3) - MAXIMUM CONDUCTED OUTPUT POWER.....</b>	<b>30</b>
APPLICABLE STANDARD .....	30
TEST PROCEDURE .....	30
TEST DATA .....	30

**FCC §15.247(d) – 100 kHz BANDWIDTH OF FREQUENCY BAND EDGE.....31**  
    APPLICABLE STANDARD .....31  
    TEST PROCEDURE .....31  
    TEST DATA .....31

**FCC §15.247(e) - POWER SPECTRAL DENSITY .....32**  
    APPLICABLE STANDARD .....32  
    TEST PROCEDURE .....32  
    TEST DATA .....32

**APPENDIX .....33**  
    APPENDIX A: DTS BANDWIDTH .....33  
    APPENDIX B: OCCUPIED CHANNEL BANDWIDTH .....38  
    APPENDIX C: MAXIMUM CONDUCTED PEAK OUTPUT POWER .....43  
    APPENDIX D: MAXIMUM POWER SPECTRAL DENSITY .....44  
    APPENDIX E: BAND EDGE MEASUREMENTS .....49  
    APPENDIX G: DUTY CYCLE.....52

## GENERAL INFORMATION

### Product Description for Equipment under Test (EUT)

Product	On-site Command and Dispatch Center
Tested Model	E-center
Frequency Range	Wi-Fi: 2412-2472MHz/2422-2462MHz
Maximum Conducted Peak Output Power	16.05dBm(802.11b), 17.95dBm(802.11g) 17.90dBm(802.11n-HT20), 17.52dBm(802.11n-HT40)
Modulation Technique	Wi-Fi: DSSS, OFDM
Antenna Specification*	2dBi(provided by the applicant)
Voltage Range	13.6V <sub>DC</sub> from Battery or DC12~16.8V from adapter
Date of Test	2020-03-06 to 2020-08-12
Sample serial number	RDG191210020-RF-S1(Assigned by BAACL, Shenzhen)
Received date	2019-12-10
Sample/EUT Status	Good condition
Adapter information	Model:PS10001 Input:100~240V,1.5A,50/60Hz Output:12~16.8V,6A/100.8W

### Objective

This test report is in accordance with Part 2-Subpart J, Part 15-Subparts A and C of the Federal Communication Commission's rules.

The tests were performed in order to determine compliance with FCC Part 15, Subpart C, and section 15.203, 15.205, 15.207, 15.209 and 15.247 rules.

### Test Methodology

All measurements contained in this report were conducted with ANSI C63.10-2013, American National Standard of Procedures for Compliance Testing of Unlicensed Wireless Devices.

And KDB 558074 D01 15.247 Meas Guidance v05r02.

All emissions measurement was performed at Bay Area Compliance Laboratories Corp. (Shenzhen). The radiated testing was performed at an antenna-to-EUT distance of 3 meters.

## Measurement Uncertainty

Parameter		Uncertainty
Occupied Channel Bandwidth		±5%
RF Output Power with Power meter		±0.73dB
RF conducted test with spectrum		±1.6dB
AC Power Lines Conducted Emissions		±1.95dB
Emissions, Radiated	Below 1GHz	±4.75dB
	Above 1GHz	±4.88dB
Temperature		±1 °C
Humidity		±6%
Supply voltages		±0.4%

*Note: The extended uncertainty given in this report is obtained by combining the standard uncertainty times the coverage factor K with the 95% confidence interval. Otherwise required by the applicant or Product Regulations, Decision Rule in this report did not consider the uncertainty.*

## Test Facility

The test site used by Bay Area Compliance Laboratories Corp. (Shenzhen) to collect test data is located on the 6/F., West Wing, Third Phase of Wanli Industrial Building, Shihua Road, Futian Free Trade Zone, Shenzhen, Guangdong, China.

The test site has been approved by the FCC under the KDB 974614 D01 and is listed in the FCC Public Access Link (PAL) database, FCC Registration No.: 342867, the FCC Designation No.: CN1221.

The test site has been registered with ISED Canada under ISED Canada Registration Number 3062B.

## SYSTEM TEST CONFIGURATION

### Description of Test Configuration

For 802.11b, 802.11g, 802.11n-HT20 and 802.11n-HT40 mode, 13 channels are provided to testing:

Channel	Frequency (MHz)	Channel	Frequency (MHz)
1	2412	8	2447
2	2417	9	2452
3	2422	10	2457
4	2427	11	2462
5	2432	12	2467
6	2437	13	2472
7	2442	/	/

For 802.11b, 802.11g, 802.11n-HT20, EUT was tested with Channel 1, 7 and 13.

For 802.11n-HT40 mode, EUT was tested with Channel 3, 7 and 11.

### Equipment Modifications

No modification was made to the EUT tested.

### EUT Exercise Software

“MT7620QA.exe”\* exercise software was used. The software and power level was provided by the applicant.

The device was tested with the worst case was performed as below:

Mode	Data rate	Power level*		
		Low channel	Middle channel	High channel
802.11b	1 Mbps	0B	09	09
802.11g	6 Mbps	00	00	00
802.11n-HT20	MCS0	00	00	00
802.11n-HT40	MCS0	00	00	00

### Duty cycle

Test Result: Compliant. Please refer to the Append.

**Support Equipment List and Details**

Manufacturer	Description	Model	Serial Number
HIKVISION	Router	DS-3WR03-E	10021642429
Grandstream	IP Phone	Unknown	Unknown
SAMSUNG	Monitor	S24E390HL	ZZFRH4ZN303357K
DELL	Laptop	LATITUDE E5430	CD3NLV1
Unknown	MIC	Unknown	Unknown
Unknown	Earphone	Unknown	Unknown
Microsoft	Keyboard	1406	0200706128743
DELL	Mouse	MOC5UO	G1900NKD

**External I/O Cable**

Cable Description	Length (m)	From Port	To
Un-shield Detachable AC cable	1.2	Adapter	LISN
Un-shield Detachable DC cable	1.0	Adapter	EUT
Un-Shielding Detachable USB Cable	1.5	EUT	Mouse
Un-Shielding Detachable USB Cable	1.5	EUT	Keyboard
Shielding Detachable HDMI Cable	1.2	EUT	Monitor
Shielding Detachable HDMI Cable	1.2	EUT	Laptop
Un-Shielding Detachable RJ45 Cable	1.2	EUT	Laptop
Un-Shielding Detachable RJ45 Cable	5.0	EUT	Router
Un-Shielding Detachable RJ45 Cable	5.0	EUT	IP Phone

### Block Diagram of Test Setup

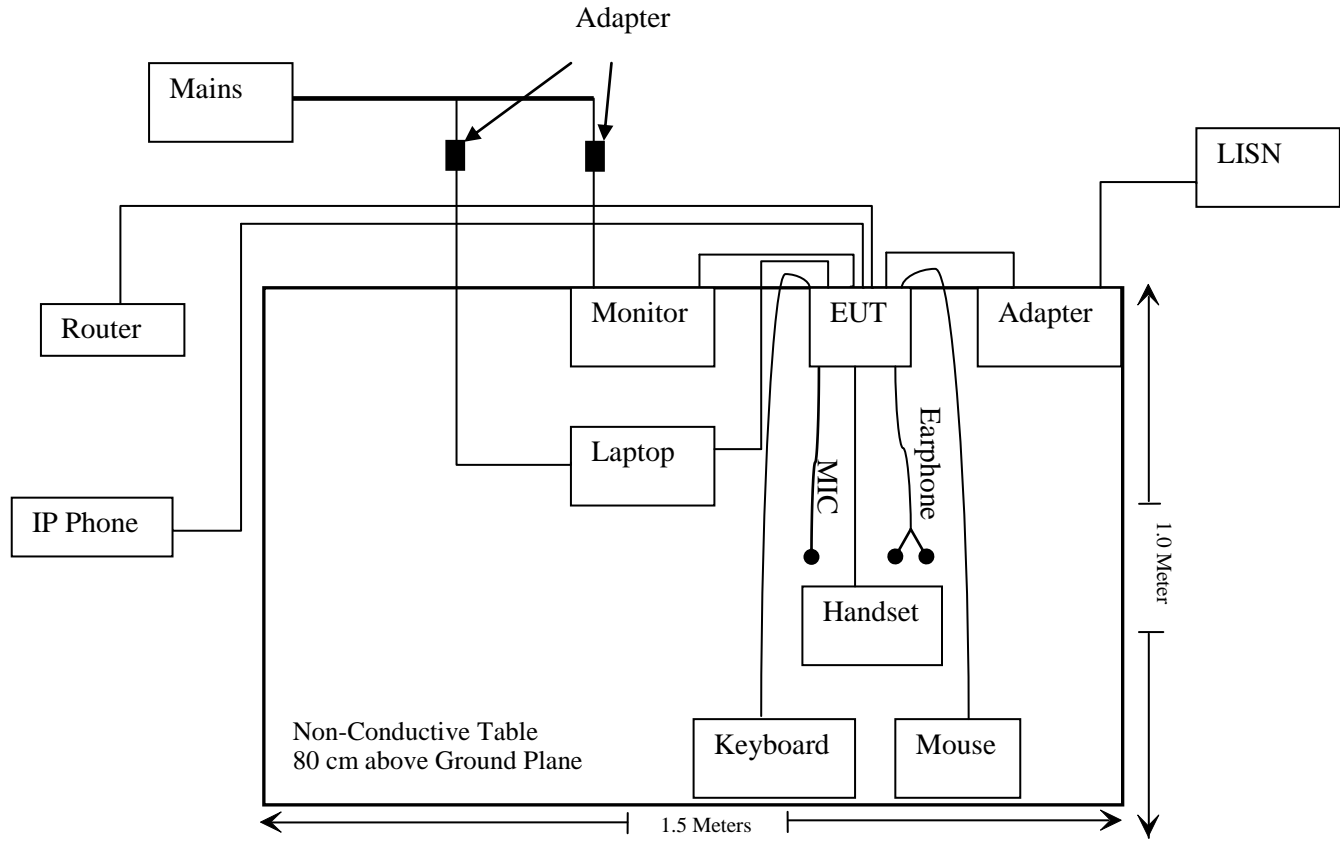



**SUMMARY OF TEST RESULTS**

<b>FCC Rules</b>	<b>Description of Test</b>	<b>Result</b>
§15.247 (i), §2.1091	Maximum Permissible Exposure(MPE)	Compliance
§15.203	Antenna Requirement	Compliance
§15.207 (a)	AC Line Conducted Emissions	Compliance
§15.205, §15.209, §15.247(d)	Spurious Emissions	Compliance
§15.247 (a)(2)	6 dB Emission Bandwidth	Compliance
§15.247(b)(3)	Maximum Conducted Output Power	Compliance
§15.247(d)	100 kHz Bandwidth of Frequency Band Edge	Compliance
§15.247(e)	Power Spectral Density	Compliance

**TEST EQUIPMENT LIST**

Manufacturer	Description	Model	Serial Number	Calibration Date	Calibration Due Date
<b>Conducted Emissions Test</b>					
Rohde & Schwarz	EMI Test Receiver	ESCI	101120	2020/08/04	2021/08/03
Rohde & Schwarz	LISN	ENV216	101613	2020/08/04	2021/08/03
Rohde & Schwarz	Transient Limitor	ESH3Z2	DE25985	2019/11/29	2020/11/28
Unknown	CE Cable	CE Cable	UF A210B-1-0720-504504	2019/11/29	2020/11/28
Rohde & Schwarz	CE Test software	EMC 32	V8.53.0	NCR	NCR
<b>Radiated Emission Test</b>					
R&S	EMI Test Receiver	ESR3	102455	2020/08/04	2021/08/03
Sonoma instrument	Pre-amplifier	310 N	186238	2020/08/04	2021/08/03
Sunol Sciences	Broadband Antenna	JB1	A040904-1	2017/12/22	2020/12/21
Unknown	Cable 2	RF Cable 2	F-03-EM197	2019/11/29	2020/11/28
Unknown	Cable	Chamber Cable 1	F-03-EM236	2019/11/29	2020/11/28
Rohde & Schwarz	Auto test software	EMC 32	V9.10	NCR	NCR
Rohde & Schwarz	Spectrum Analyzer	FSV40-N	102259	2020/7/22	2021/7/21
COM-POWER	Pre-amplifier	PA-122	181919	2019/11/29	2020/11/28
Quinstar	Amplifier	QLW-18405536-J0	15964001002	2019/11/29	2020/11/28
Sunol Sciences	Horn Antenna	DRH-118	A052604	2017/12/22	2020/12/21
Insulted Wire Inc.	RF Cable	SPS-2503-3150	02222010	2019/11/29	2020/11/28
Unknow	RF Cable	W1101-EQ1 OUT	F-19-EM005	2019/11/29	2020/11/28
SNSD	Band Reject filter	BSF2402-2480MN-0898-001	2.4G filter	2020/04/20	2021/04/20
Ducommun Technologies	Horn antenna	ARH-4223-02	1007726-021304	2017/12/06	2020/12/05
<b>RF Conducted Test</b>					
Tonscend Corporation	RF control Unit	JS0806-2	19D8060154	2019/7/10	2020/7/9
Rohde & Schwarz	Signal and Spectrum Analyzer	FSV40	101473	2019/7/22	2020/7/21
Unknown	RF Cable	Unknown	2301 276	2019/11/29	2020/11/28

**\* Statement of Traceability:** Bay Area Compliance Laboratories Corp. (Shenzhen) attests that all calibrations have been performed in accordance to requirements that traceable to National Primary Standards and International System of Units (SI).

**FCC §15.247 (i) & §2.1091- MAXIMUM PERMISSIBLE EXPOSURE (MPE)**

**Applicable Standard**

According to subpart 15.247 (i) and subpart 2.1091 systems operating under the provisions of this section shall be operated in a manner that ensures the public is not exposed to RF energy level in excess of the communication guidelines.

Limits for General Population/Uncontrolled Exposure

Limits for General Population/Uncontrolled Exposure				
Frequency Range (MHz)	Electric Field Strength (V/m)	Magnetic Field Strength (A/m)	Power Density (mW/cm <sup>2</sup> )	Averaging Time (Minutes)
0.3-1.34	614	1.63	*(100)	30
1.34-30	824/f	2.19/f	*(180/f <sup>2</sup> )	30
30-300	27.5	0.073	0.2	30
300-1500	/	/	f/1500	30
1500-100,000	/	/	1.0	30

f = frequency in MHz

\* = Plane-wave equivalent power density

**Result**

**Calculated Formulary:**

Predication of MPE limit at a given distance

$$S = \frac{PG}{4\pi R^2}$$

S = power density (in appropriate units, e.g. mW/cm<sup>2</sup>)

P = power input to the antenna (in appropriate units, e.g., mW).

G = power gain of the antenna in the direction of interest relative to an isotropic radiator, the power gain factor, is normally numeric gain.

R = distance to the center of radiation of the antenna (appropriate units, e.g., cm)

For simultaneously transmit system, the calculated power density should comply with:

$$\sum_i \frac{S_i}{S_{Limit,i}} \leq 1$$

Mode	Frequency (MHz)	Antenna Gain		Max Tune Up Conducted Power		Evaluation Distance (cm)	Power Density (mW/cm <sup>2</sup> )	MPE Limit (mW/cm <sup>2</sup> )
		(dBi)	(numeric)	(dBm)	(mW)			
Wi-Fi	2412-2472	2.0	1.58	18.0	63.1	20	0.020	1.0
LTE Data Module								
WCDMA Band 2	1850-1910	2.0	1.58	24.0	251.2	20	0.079	1.0
WCDMA Band 4	1710-1755	2.0	1.58	23.0	199.5	20	0.063	1.0
WCDMA Band 5	824-849	2.0	1.58	24.0	251.2	20	0.079	0.55
LTE Band 2	1850-1910	2.0	1.58	24.0	251.2	20	0.079	1.0
LTE Band 4	1710-1755	2.0	1.58	23.0	199.5	20	0.063	1.0
LTE Band 5	824-849	2.0	1.58	23.0	199.5	20	0.063	0.55
LTE Band 12	699-716	2.0	1.58	23.0	199.5	20	0.063	0.466
LTE Band 13	777-787	2.0	1.58	23.0	199.5	20	0.063	0.518
LTE Voice Module (FCC ID: XMR201808EC25AF)								
WCDMA Band 2	1850-1910	2.0	1.58	25.0	316.23	20	0.099	1.0
WCDMA Band 4	1710-1755	2.0	1.58	25.0	316.23	20	0.099	1.0
WCDMA Band 5	824-849	2.0	1.58	25.0	316.23	20	0.099	0.55
LTE Band 2	1850-1910	2.0	1.58	25.0	316.23	20	0.099	1.0
LTE Band 4	1710-1755	2.0	1.58	25.0	316.23	20	0.099	1.0
LTE Band 5	824-849	2.0	1.58	25.0	316.23	20	0.099	0.55
LTE Band 12	699-716	2.0	1.58	25.0	316.23	20	0.099	0.466
LTE Band 13	777-787	2.0	1.58	25.0	316.23	20	0.099	0.518
LTE Band 14	788-798	2.0	1.58	25.0	316.23	20	0.099	0.525
LTE Band 66	1710-1780	2.0	1.58	25.0	316.23	20	0.099	1.0
LTE Band 71	663-698	2.0	1.58	25.0	316.23	20	0.099	0.442

- Note: 1. the tune up conducted power was declared by the applicant  
2. the Wi-Fi, LTE Voice module and LTE Data module can transmit at the same time.  
3. Please refer to the MPE report of the FCC ID: XMR201808EC25AF for the LTE voice module output power.

So the worst simultaneous transmitting consideration:

$$\begin{aligned} \text{The ratio} &= \text{MPE}_{\text{Wi-Fi}}/\text{limit} + \text{MPE}_{\text{LTE Voice Module}}/\text{limit} + \text{MPE}_{\text{LTE Data Module}}/\text{limit} \\ &= 0.02/1.0 + 0.079/0.55 + 0.099/0.442 \\ &= 0.39 < 1.0 \end{aligned}$$

To maintain compliance with the FCC's RF exposure guidelines, place the equipment at least 20cm from nearby persons.

**Result: Compliance**

---

## **FCC §15.203 - ANTENNA REQUIREMENT**

---

### **Applicable Standard**

According to § 15.203, an intentional radiator shall be designed to ensure that no antenna other than that furnished by the responsible party shall be used with the device. The use of a permanently attached antenna or of an antenna that uses a unique coupling to the intentional radiator shall be considered sufficient to comply with the provisions of this section. The manufacturer may design the unit so that a broken antenna can be replaced by the user, but the user of a standard antenna jack or electrical connector is prohibited. The structure and application of the EUT were analyzed to determine compliance with section §15.203 of the rules. §15.203 state that the subject device must meet the following criteria:

- a. Antenna must be permanently attached to the unit.
- b. Antenna must use a unique type of connector to attach to the EUT.

Unit must be professionally installed, and installer shall be responsible for verifying that the correct antenna is employed with the unit.

And according to FCC 47 CFR section 15.247 (b), if the transmitting antennas of directional gain greater than 6dBi are used, the power shall be reduced by the amount in dB that the directional gain of the antenna exceeds 6 dBi.

### **Antenna Connector Construction**

The EUT has one internal antenna arrangement which was permanently attached and the antenna gain is 2.0dBi, fulfill the requirement of this section. Please refer to the EUT photos.

**Result:** Compliance.

## FCC §15.207 (a) – AC LINE CONDUCTED EMISSIONS

### Applicable Standard

FCC §15.207

### EUT Setup

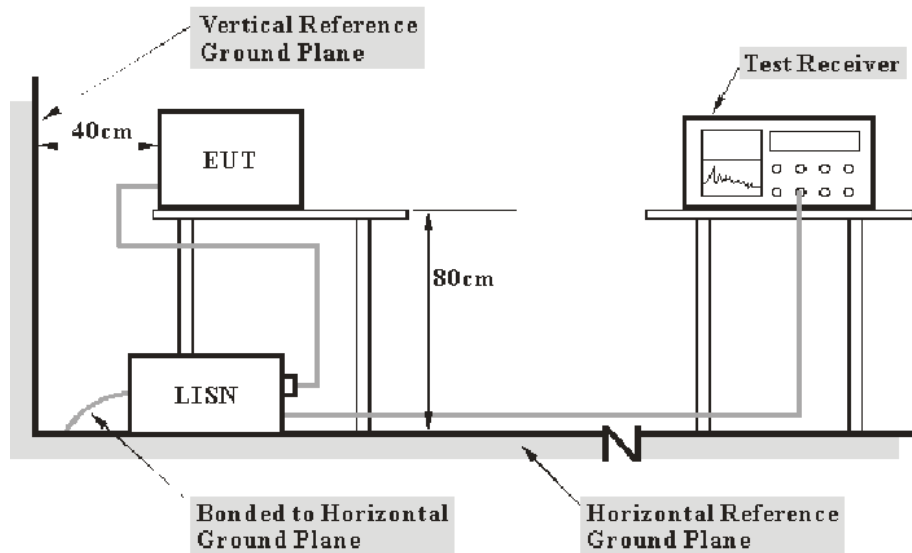

- Note: 1. Support units were connected to second LISN.  
 2. Both of LISNs (AMN) 80 cm from EUT and at the least 80 cm from other units and other metal planes support units.

The setup of EUT is according with per ANSI C63.10-2013 measurement procedure. The specification used was with the FCC Part 15.207 limits.

The spacing between the peripherals was 10 cm.

### EMI Test Receiver Setup

The EMI test receiver was set to investigate the spectrum from 150 kHz to 30 MHz.

During the conducted emission test, the EMI test receiver was set with the following configurations:

Frequency Range	IF B/W
150 kHz – 30 MHz	9 kHz

### Test Procedure

During the conducted emission test, the adapter was connected to the outlet of the LISN.

Maximizing procedure was performed on the six (6) highest emissions of the EUT.

All final data was recorded in the Quasi-peak and average detection mode.

## Corrected Factor & Margin Calculation

The Corrected factor is calculated by adding LISN VDF (Voltage Division Factor), Cable Loss and Transient Limiter Attenuation. The basic equation is as follows:

$$\text{Correction Factor} = \text{LISN VDF} + \text{Cable Loss} + \text{Transient Limiter Attenuation}$$

The “**Margin**” column of the following data tables indicates the degree of compliance with the applicable limit. For example, a margin of 7 dB means the emission is 7 dB below the limit. The equation for margin calculation is as follows:

$$\text{Margin} = \text{Limit} - \text{Corrected Amplitude}$$

## Test Data

### Environmental Conditions

<b>Temperature:</b>	25°C
<b>Relative Humidity:</b>	65 %
<b>ATM Pressure:</b>	101.0 kPa

*The testing was performed by Haiguo Li on 2020-08-04.*

*EUT operation mode: Transmitting (worst case at 802.11g mode, middle channel)*

**AC 120V/60 Hz, Line**

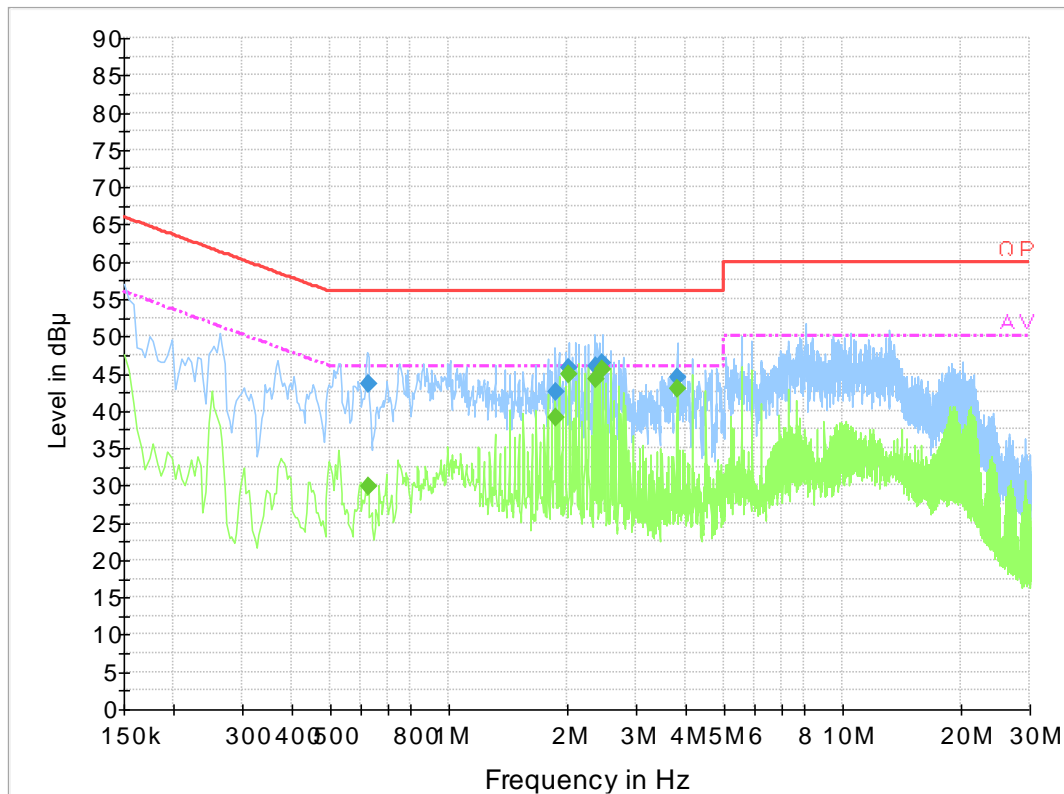

**Final Result 1**

Frequency (MHz)	QuasiPeak (dBµ V)	Bandwidth (kHz)	Line	Corr. (dB)	Margin (dB)	Limit (dBµ V)
0.628670	43.7	9.000	L1	19.8	12.3	56.0
1.870010	42.5	9.000	L1	19.9	13.5	56.0
2.027610	45.9	9.000	L1	19.9	10.1	56.0
2.381190	46.0	9.000	L1	19.9	10.0	56.0
2.461070	46.4	9.000	L1	19.8	9.6	56.0
3.808850	44.5	9.000	L1	19.9	11.5	56.0

**Final Result 2**

Frequency (MHz)	Average (dBµ V)	Bandwidth (kHz)	Line	Corr. (dB)	Margin (dB)	Limit (dBµ V)
0.628670	29.8	9.000	L1	19.8	16.2	46.0
1.870010	39.0	9.000	L1	19.9	7.0	46.0
2.027610	44.9	9.000	L1	19.9	1.1	46.0
2.381190	44.3	9.000	L1	19.9	1.7	46.0
2.461070	45.6	9.000	L1	19.8	0.4	46.0
3.808850	42.9	9.000	L1	19.9	3.1	46.0



**AC 120V/60 Hz, Neutral**

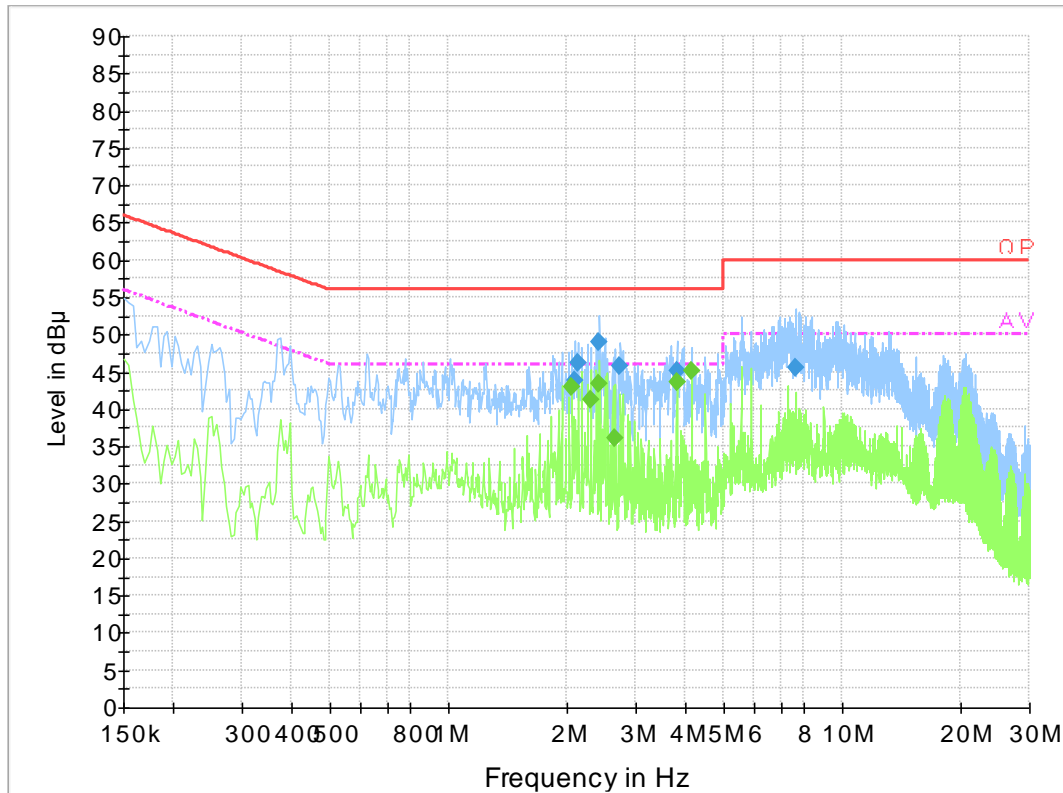

**Final Result 1**

Frequency (MHz)	QuasiPeak (dBµ V)	Bandwidth (kHz)	Line	Corr. (dB)	Margin (dB)	Limit (dBµ V)
2.106410	43.8	9.000	N	19.9	12.2	56.0
2.145810	46.3	9.000	N	19.9	9.7	56.0
2.425610	49.0	9.000	N	19.8	7.0	56.0
2.740870	45.7	9.000	N	19.8	10.3	56.0
3.812850	45.2	9.000	N	19.9	10.8	56.0
7.663670	45.5	9.000	N	19.9	14.5	60.0

**Final Result 2**

Frequency (MHz)	Average (dBµ V)	Bandwidth (kHz)	Line	Corr. (dB)	Margin (dB)	Limit (dBµ V)
2.066000	42.9	9.000	N	19.9	3.1	46.0
2.306000	41.2	9.000	N	19.8	4.8	46.0
2.422000	43.4	9.000	N	19.8	2.6	46.0
2.662000	36.0	9.000	N	19.8	10.0	46.0
3.810000	43.6	9.000	N	19.9	2.4	46.0
4.158000	45.2	9.000	N	19.9	0.8	46.0

**FCC §15.209, §15.205 & §15.247(d) - SPURIOUS EMISSIONS**

**Applicable Standard**

FCC §15.247 (d); §15.209; §15.205;

**EUT Setup**

**Below 1 GHz:**

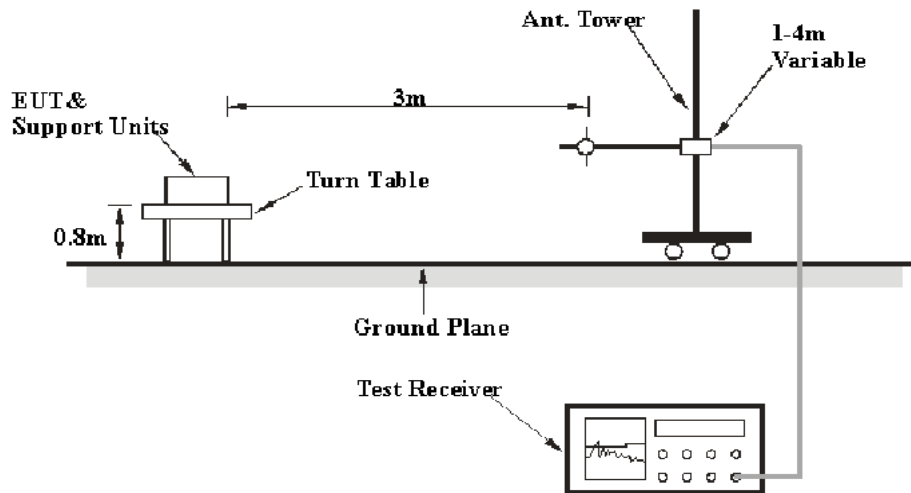

**Above 1GHz:**

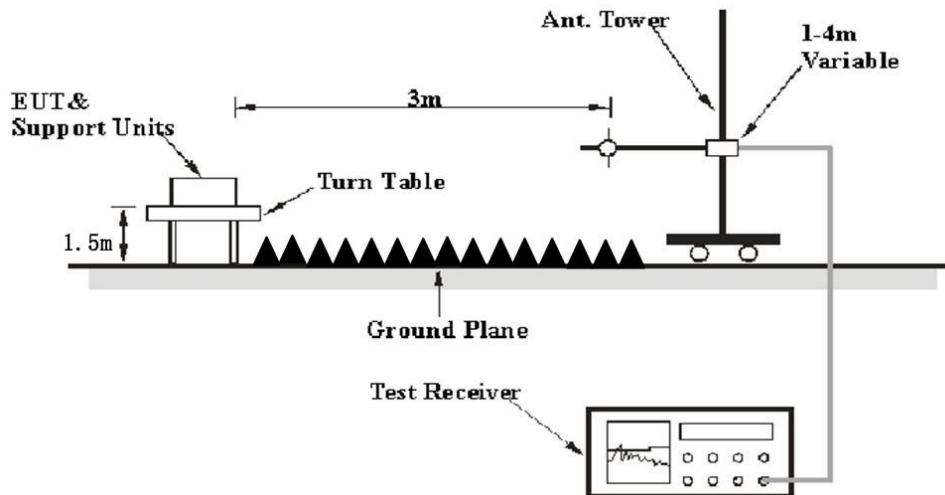

The radiated emission tests were performed in the 3 meters test site, using the setup accordance with the ANSI C63.10-2013. The specification used was the FCC 15.209, and FCC 15.247 limits.

## EMI Test Receiver & Spectrum Analyzer Setup

During the radiated emission test, the EMI test receiver & Spectrum Analyzer Setup were set with the following configurations:

Frequency Range	RBW	Video B/W	IF B/W	Measurement
30 MHz – 1000 MHz	100 kHz	300 kHz	120 kHz	QP
Above 1 GHz	1MHz	3 MHz	/	PK
	1MHz	10 Hz <sup>Note 1</sup>	/	Average
	1MHz	> 1/T <sup>Note 2</sup>	/	Average

Note 1: when duty cycle is no less than 98%

Note 2: when duty cycle is less than 98%

## Test Procedure

Maximizing procedure was performed on the highest emissions to ensure that the EUT complied with all installation combinations.

Data was recorded in Quasi-peak detection mode for frequency range of 30 MHz-1 GHz, peak and Average detection modes for frequencies above 1 GHz.

## Corrected Amplitude & Margin Calculation

The Corrected Amplitude is calculated by adding the Antenna Factor and Cable Loss, and subtracting the Amplifier Gain from the Meter Reading. The basic equation is as follows:

$$\text{Corrected Amplitude} = \text{Meter Reading} + \text{Antenna Factor} + \text{Cable Loss} - \text{Amplifier Gain}$$

The “**Margin**” column of the following data tables indicates the degree of compliance with the applicable limit. For example, a margin of 7dB means the emission is 7dB below the limit. The equation for margin calculation is as follows:

$$\text{Margin} = \text{Limit} - \text{Corrected Amplitude}$$

## Test Data

### Environmental Conditions

<b>Temperature:</b>	29°C
<b>Relative Humidity:</b>	58 %
<b>ATM Pressure:</b>	101.0 kPa

*The testing was performed by Harris He on 2020-08-12 for below 1GHz and Leven Gan on 2020-07-24 for above 1GHz.*

*EUT operation mode: Transmitting*

**30 MHz~1 GHz:** (worst case at 802.11g mode, middle channel)

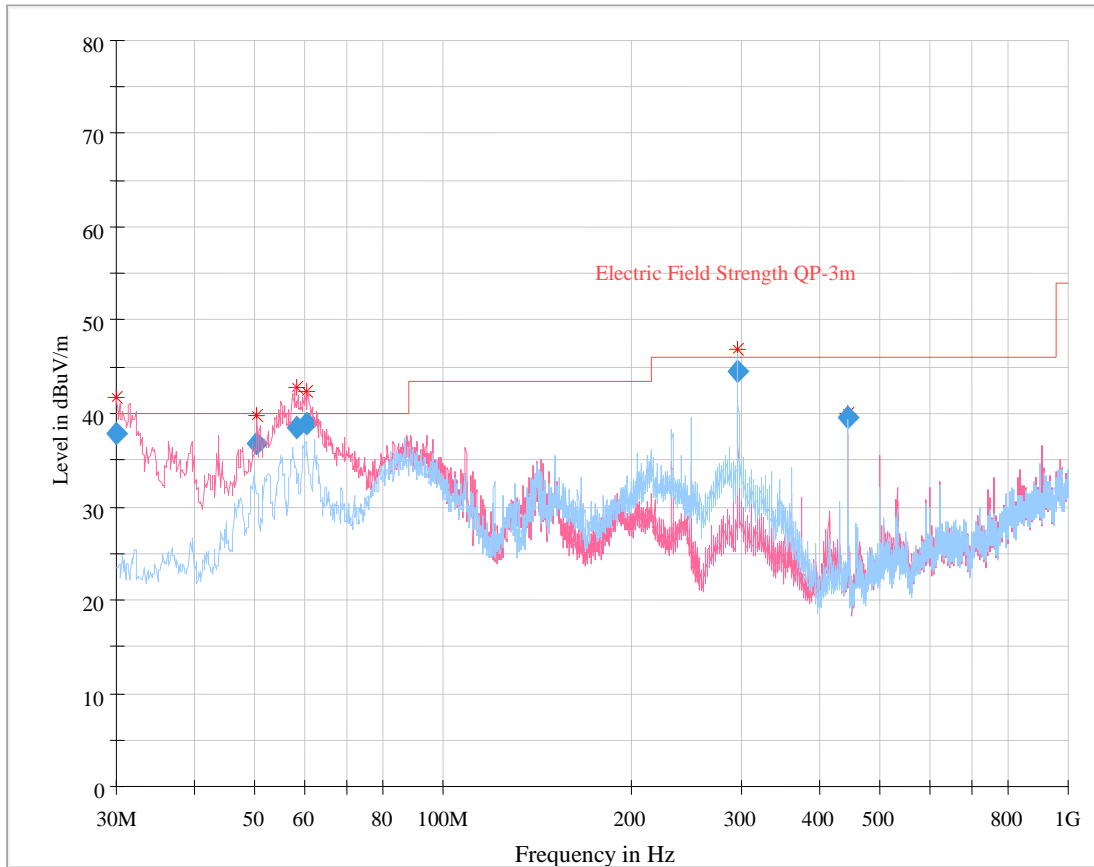

**Final Result**

Frequency (MHz)	QuasiPeak (dB $\mu$ V/m)	Limit (dB $\mu$ V/m)	Margin (dB)	Height (cm)	Pol	Azimuth (deg)	Corr. (dB)
30.075000	37.87	40.00	2.13	109.0	V	342.0	-7.7
50.437125	36.68	40.00	3.32	103.0	V	258.0	-19.7
58.162125	38.53	40.00	1.47	102.0	V	233.0	-20.1
60.424375	38.86	40.00	1.14	109.0	V	266.0	-20.2
296.733375	44.42	46.00	1.58	110.0	H	20.0	-10.8
445.074250	39.66	46.00	6.34	191.0	H	267.0	-8.4

**1 GHz-25 GHz (Wi-Fi):****802.11b Mode:**

Frequency (MHz)	Receiver		Turntable Degree	Rx Antenna		Corrected Factor (dB/m)	Corrected Amplitude (dB $\mu$ V/m)	Limit (dB $\mu$ V/m)	Margin (dB)
	Reading (dB $\mu$ V)	PK/QP/Ave.		Height (m)	Polar (H/V)				
Low Channel (2412 MHz)									
2389.91	27.55	PK	266	1.0	H	31.87	59.42	74	14.58
2389.91	13.97	Ave.	266	1.0	H	31.87	45.84	54	8.16
2484.65	27.52	PK	104	2.3	H	32.13	59.65	74	14.35
2484.65	13.95	Ave.	104	2.3	H	32.13	46.08	54	7.92
4824.00	45.02	PK	81	1.2	H	6.28	51.30	74	22.70
4824.00	35.09	Ave.	81	1.2	H	6.28	41.37	54	12.63
Middle Channel (2442MHz)									
4884.00	42.74	PK	104	1.6	H	6.76	49.50	74	24.50
4884.00	28.18	Ave.	104	1.6	H	6.76	34.94	54	19.06
High Channel (2472 MHz)									
2388.68	27.54	PK	43	1.9	H	31.87	59.41	74	14.59
2388.68	13.95	Ave.	43	1.9	H	31.87	45.82	54	8.18
2483.69	27.66	PK	219	1.6	H	32.13	59.79	74	14.21
2483.69	14.02	Ave.	219	1.6	H	32.13	46.15	54	7.85
4944.00	42.39	PK	63	1.7	H	6.76	49.15	74	24.85
4944.00	29.35	Ave.	63	1.7	H	6.76	36.11	54	17.89

**802.11g Mode:**

Frequency (MHz)	Receiver		Turntable Degree	Rx Antenna		Corrected Factor (dB/m)	Corrected Amplitude (dBμV/m)	Limit (dBμV/m)	Margin (dB)
	Reading (dBμV)	PK/QP/Ave.		Height (m)	Polar (H/V)				
Low Channel (2412 MHz)									
2389.47	27.59	PK	110	1.9	H	31.87	59.46	74	14.54
2389.47	13.97	Ave.	110	1.9	H	31.87	45.84	54	8.16
2484.73	27.66	PK	125	2.2	H	32.13	59.79	74	14.21
2484.73	14.04	Ave.	125	2.2	H	32.13	46.17	54	7.83
4824.00	42.57	PK	25	1.6	H	6.28	48.85	74	25.15
4824.00	27.52	Ave.	25	1.6	H	6.28	33.80	54	20.20
Middle Channel (2442MHz)									
4884.00	42.58	PK	355	2.1	H	6.76	49.34	74	24.66
4884.00	27.50	Ave.	355	2.1	H	6.76	34.26	54	19.74
High Channel (2472 MHz)									
2388.68	27.64	PK	315	2.4	H	31.87	59.51	74	14.49
2388.68	14.33	Ave.	315	2.4	H	31.87	46.20	54	7.80
2484.73	28.36	PK	79	1.5	H	32.13	60.49	74	13.51
2484.73	15.98	Ave.	79	1.5	H	32.13	48.11	54	5.89
4944.00	42.60	PK	297	1.2	H	6.76	49.36	74	24.64
4944.00	27.47	Ave.	297	1.2	H	6.76	34.23	54	19.77

**802.11n-HT20 Mode:**

Frequency (MHz)	Receiver		Turntable Degree	Rx Antenna		Corrected Factor (dB/m)	Corrected Amplitude (dBμV/m)	Limit (dBμV/m)	Margin (dB)
	Reading (dBμV)	PK/QP/Ave.		Height (m)	Polar (H/V)				
Low Channel (2412 MHz)									
2388.44	27.74	PK	202	2.0	H	31.87	59.61	74	14.39
2388.44	14.27	Ave.	202	2.0	H	31.87	46.14	54	7.86
2484.56	27.62	PK	318	1.7	H	32.13	59.75	74	14.25
2484.56	14.25	Ave.	318	1.7	H	32.13	46.38	54	7.62
4824.00	42.42	PK	139	2.4	H	6.28	48.70	74	25.30
4824.00	28.83	Ave.	139	2.4	H	6.28	35.11	54	18.89
Middle Channel (2442MHz)									
4884.00	42.47	PK	280	2.0	H	6.76	49.23	74	24.77
4884.00	28.74	Ave.	280	2.0	H	6.76	35.50	54	18.50
High Channel (2472 MHz)									
2388.44	27.67	PK	191	1.9	H	31.87	59.54	74	14.46
2388.44	14.25	Ave.	191	1.9	H	31.87	46.12	54	7.88
2484.56	29.15	PK	262	1.2	H	32.13	61.28	74	12.72
2484.56	16.57	Ave.	262	1.2	H	32.13	48.70	54	5.30
4944.00	42.27	PK	226	2.0	H	6.76	49.03	74	24.97
4944.00	28.28	Ave.	226	2.0	H	6.76	35.04	54	18.96

**802.11n-HT40 Mode:**

Frequency (MHz)	Receiver		Turntable Degree	Rx Antenna		Corrected Factor (dB/m)	Corrected Amplitude (dBµV/m)	Limit (dBµV/m)	Margin (dB)
	Reading (dBµV)	PK/QP/Ave.		Height (m)	Polar (H/V)				
Low Channel (2422 MHz)									
2389.26	27.72	PK	276	2.4	H	31.87	59.59	74	14.41
2389.26	15.18	Ave.	276	2.4	H	31.87	47.05	54	6.95
2484.52	27.65	PK	176	2.3	H	32.13	59.78	74	14.22
2484.52	15.01	Ave.	176	2.3	H	32.13	47.14	54	6.86
4844.00	41.98	PK	339	1.3	H	6.28	48.26	74	25.74
4844.00	29.08	Ave.	339	1.3	H	6.28	35.36	54	18.64
Middle Channel (2442MHz)									
4884.00	42.22	PK	6	1.9	H	6.76	48.98	74	25.02
4884.00	29.12	Ave.	6	1.9	H	6.76	35.88	54	18.12
High Channel (2462 MHz)									
2388.52	27.78	PK	336	1.6	H	31.87	59.65	74	14.35
2388.52	15.24	Ave.	336	1.6	H	31.87	47.11	54	6.89
2483.99	33.56	PK	275	1.9	H	32.13	65.69	74	8.31
2483.99	18.00	Ave.	275	1.9	H	32.13	50.13	54	3.87
4924.00	43.11	PK	315	1.4	H	6.76	49.87	74	24.13
4924.00	29.11	Ave.	315	1.4	H	6.76	35.87	54	18.13

**Note:**

Corrected Factor = Antenna factor (RX) + Cable Loss – Amplifier Factor

Corrected Amplitude = Corrected Factor + Reading

Margin = Limit - Corrected. Amplitude

The other spurious emission which is 20dB to the limit was not recorded.



### Pre-scan with Wi-Fi Low channel in 802.11b mode Horizontal

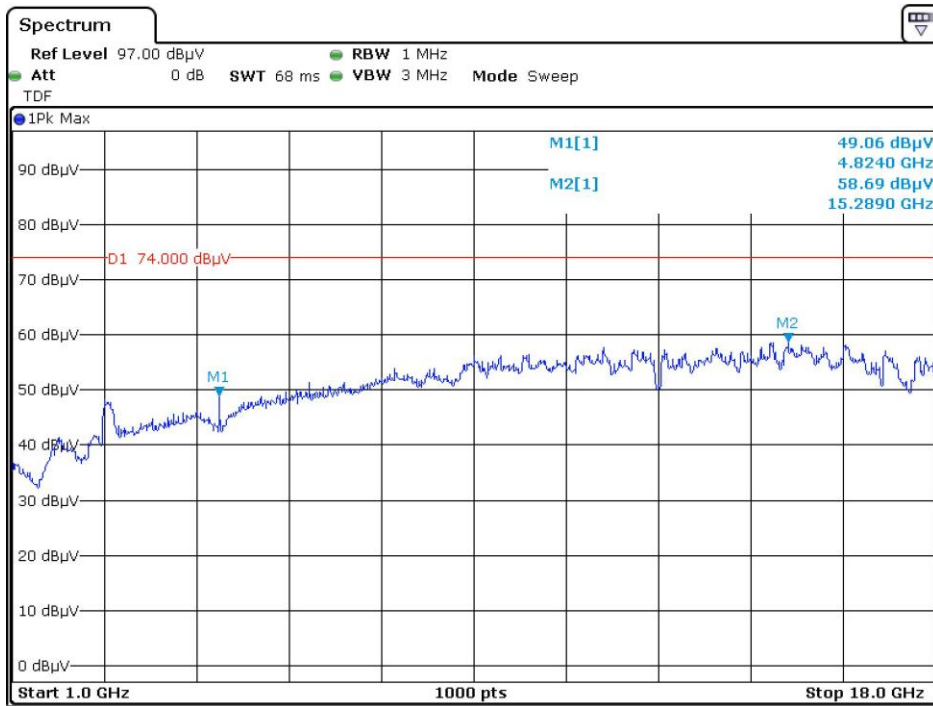

Date: 24.JUL.2020 18:54:34

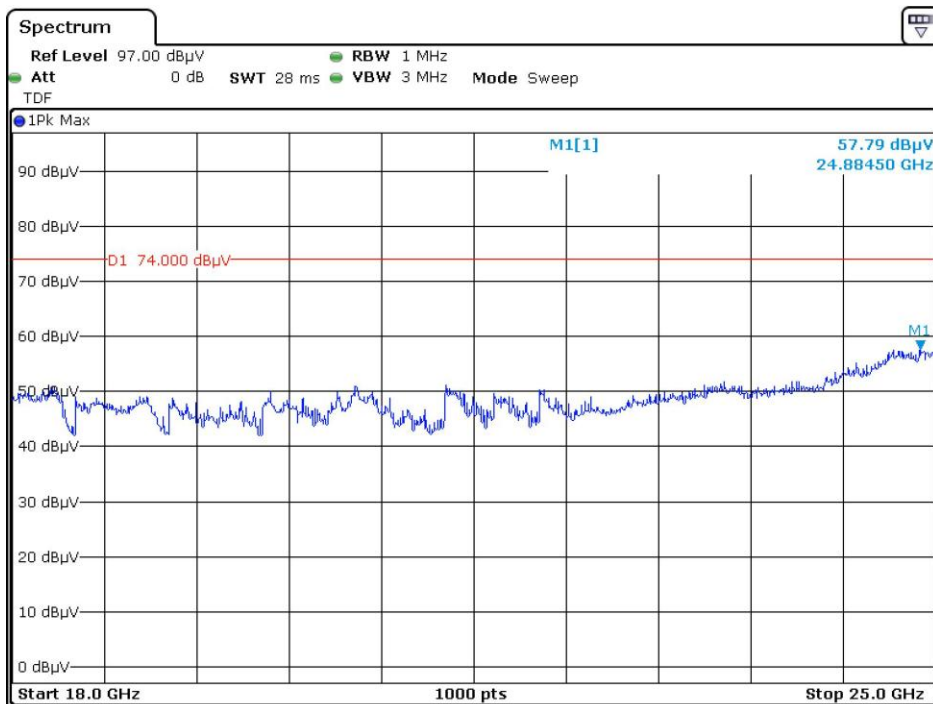

Date: 24.JUL.2020 19:43:29

### Vertical

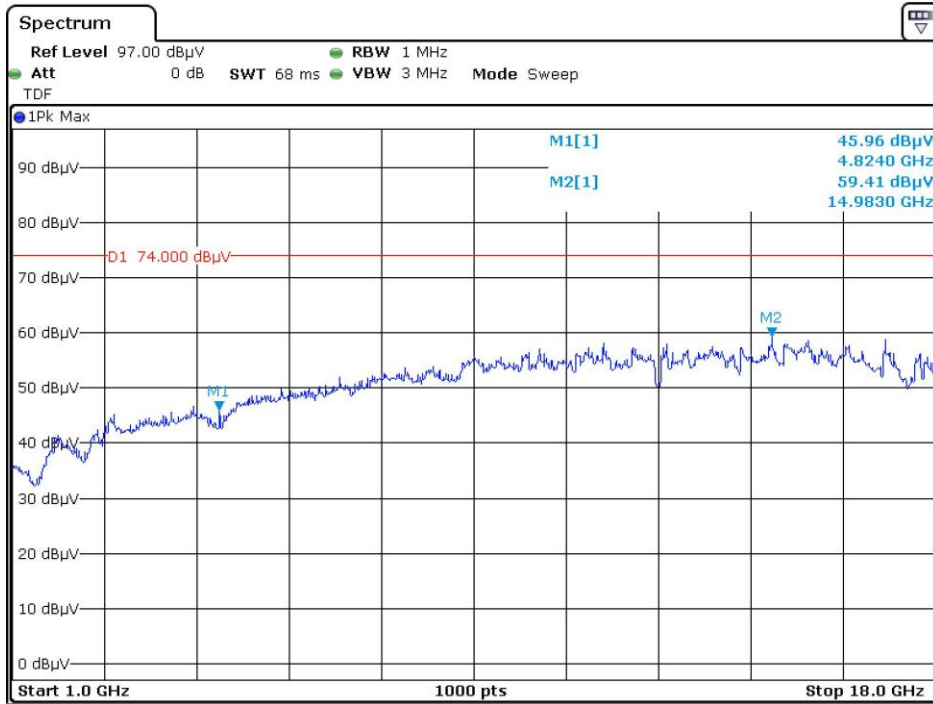

Date: 24.JUL.2020 19:06:03

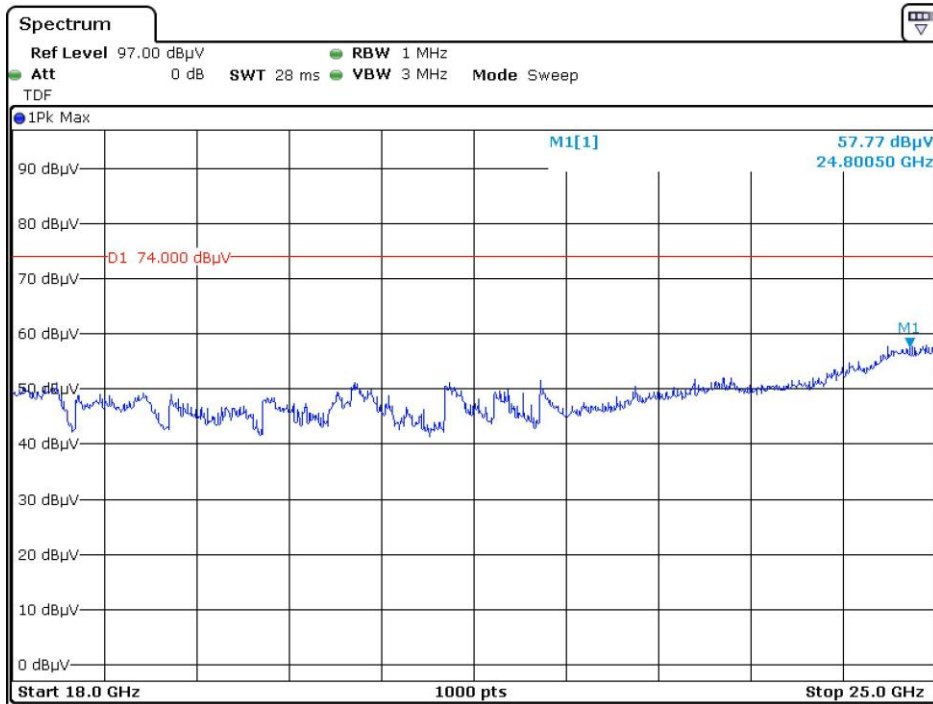

Date: 24.JUL.2020 21:46:17

### Average Horizontal

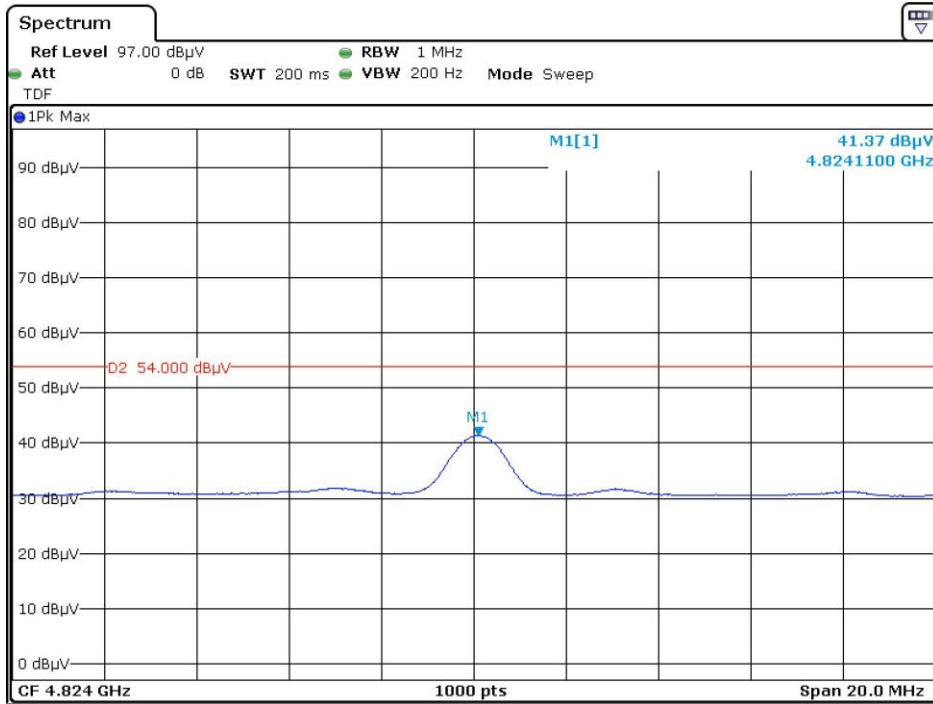

Date: 24.JUL.2020 18:59:59

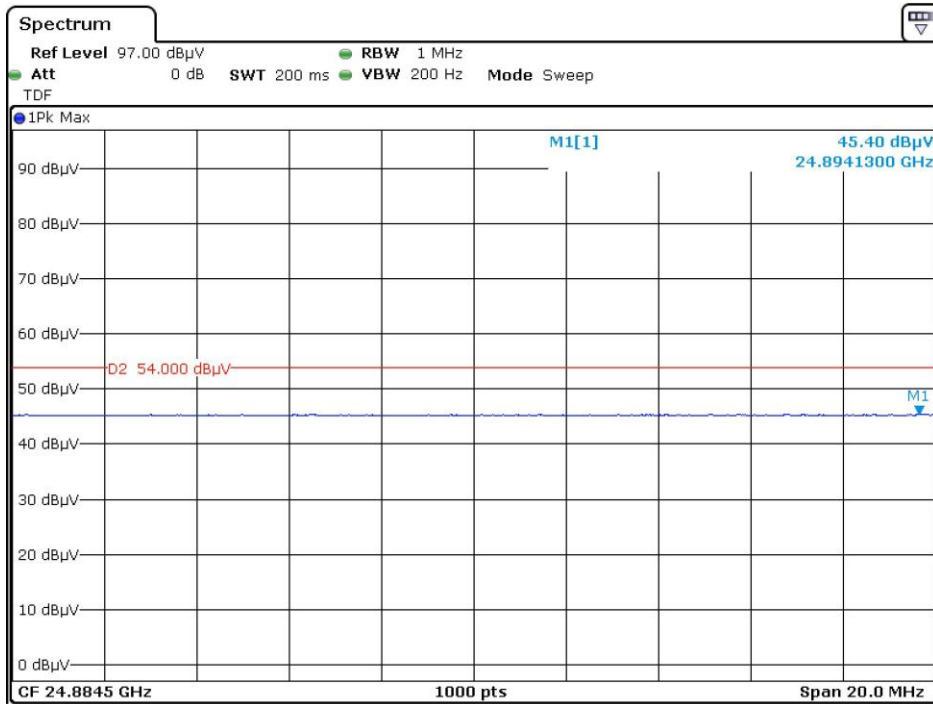

Date: 24.JUL.2020 19:47:50

### Vertical

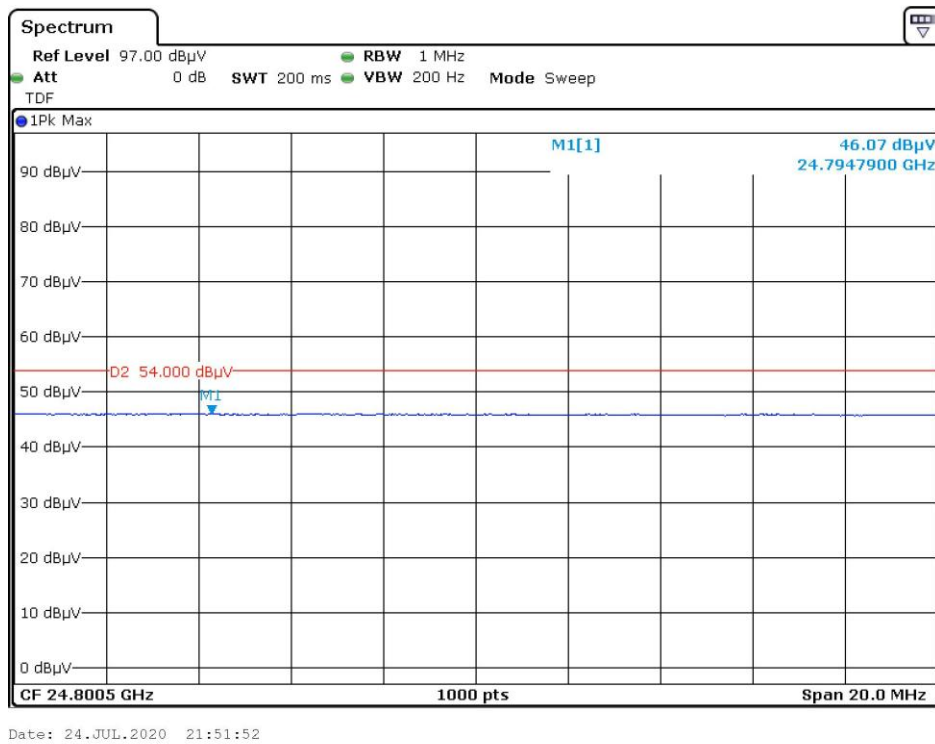
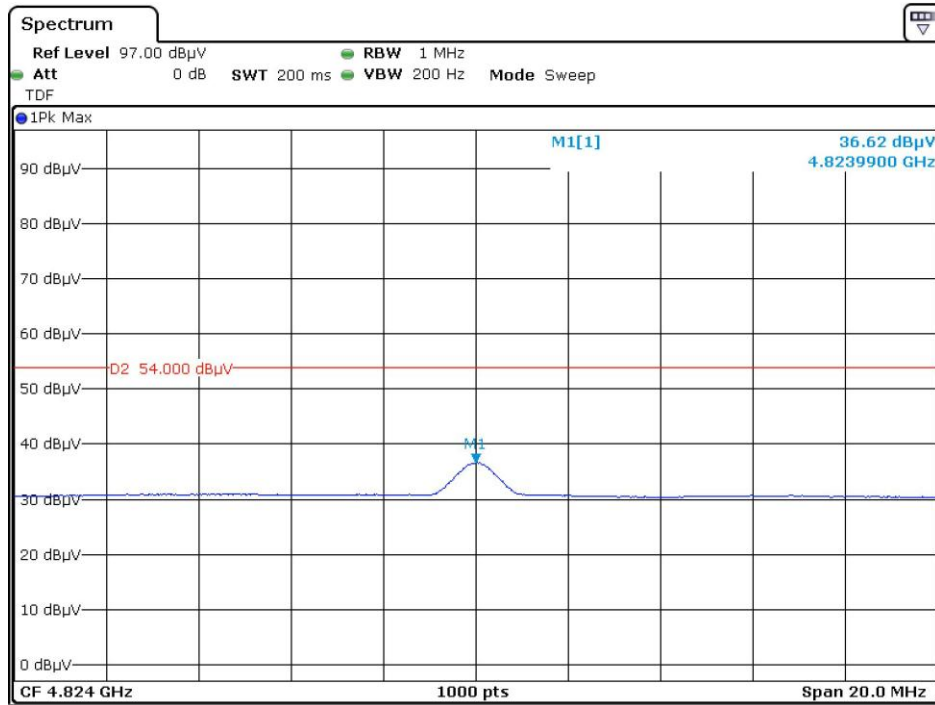

## FCC §15.247(a) (2) – 6 dB EMISSION BANDWIDTH

### Applicable Standard

Systems using digital modulation techniques may operate in the 902–928 MHz, 2400–2483.5 MHz, and 5725–5850 MHz bands. The minimum 6 dB bandwidth shall be at least 500 kHz.

### Test Procedure

1. Check the calibration of the measuring instrument using either an internal calibrator or a known signal from an external generator.
2. Position the EUT without connection to measurement instrument. Turn on the EUT and connect it to measurement instrument. Then set it to any one convenient frequency within its operating range. Set a reference level on the measuring instrument equal to the highest peak value.
3. Measure the frequency difference of two frequencies that were attenuated 6 dB from the reference level. Record the frequency difference as the emission bandwidth.
4. Repeat above procedures until all frequencies measured were complete.

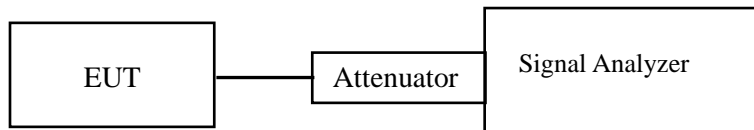

### Test Data

#### Environmental Conditions

<b>Temperature:</b>	27 °C
<b>Relative Humidity:</b>	54 %
<b>ATM Pressure:</b>	101.0 kPa

*The testing was performed by Cary Guan on 2020-03-06.*

*EUT operation mode: Transmitting*

Test Result: Compliant. Please refer to the Appendix.

## FCC §15.247(b) (3) - MAXIMUM CONDUCTED OUTPUT POWER

### Applicable Standard

According to FCC §15.247(b) (3), for systems using digital modulation in the 902-928 MHz, 2400-2483.5 MHz, and 5725-5850 MHz bands: 1 Watt. As an alternative to a peak power measurement, compliance with the one Watt limit can be based on a measurement of the maximum conducted output power. Maximum Conducted Output Power is defined as the total transmit power delivered to all antennas and antenna elements averaged across all symbols in the signaling alphabet when the transmitter is operating at its maximum power control level. Power must be summed across all antennas and antenna elements. The average must not include any time intervals during which the transmitter is off or is transmitting at a reduced power level. If multiple modes of operation are possible (e.g., alternative modulation methods), the maximum conducted output power is the highest total transmit power occurring in any mode.

### Test Procedure

1. Place the EUT on a bench and set it in transmitting mode.
2. Remove the antenna from the EUT and then connect a low loss RF cable from the antenna port to one test equipment.
3. Add a correction factor to the display.

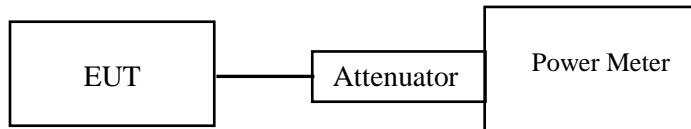

### Test Data

#### Environmental Conditions

<b>Temperature:</b>	27 °C
<b>Relative Humidity:</b>	54 %
<b>ATM Pressure:</b>	101.0 kPa

*The testing was performed by Cary Guan on 2020-03-06.*

*EUT operation mode: Transmitting*

Test Result: Compliant. Please refer to the Appendix.

## FCC §15.247(d) – 100 kHz BANDWIDTH OF FREQUENCY BAND EDGE

### Applicable Standard

In any 100 kHz bandwidth outside the frequency band in which the spread spectrum or digitally modulated intentional radiator is operating, the radio frequency power that is produced by the intentional radiator shall be at least 20 dB below that in the 100 kHz bandwidth within the band that contains the highest level of the desired power, based on either an RF conducted or a radiated measurement, provided the transmitter demonstrates compliance with the peak conducted power limits. If the transmitter complies with the conducted power limits based on the use of RMS averaging over a time interval, as permitted under paragraph (b)(3) of this section, the attenuation required under this paragraph shall be 30 dB instead of 20 dB. Attenuation below the general limits specified in §15.209(a) is not required. In addition, radiated emissions which fall in the restricted bands, as defined in §15.205(a), must also comply with the radiated emission limits specified in §15.209(a) (see §15.205(c)).

### Test Procedure

1. Check the calibration of the measuring instrument using either an internal calibrator or a known signal from an external generator.
2. Position the EUT without connection to measurement instrument. Turn on the EUT and connect its antenna terminal to measurement instrument via a low loss cable. Then set it to any one measured frequency within its operating range, and make sure the instrument is operated in its linear range.
3. Set RBW to 100 kHz and VBW of spectrum analyzer to 300 kHz with a convenient frequency span including 100 kHz bandwidth from band edge.
4. Measure the highest amplitude appearing on spectral display and set it as a reference level. Plot the graph with marking the highest point and edge frequency.
5. Repeat above procedures until all measured frequencies were complete.

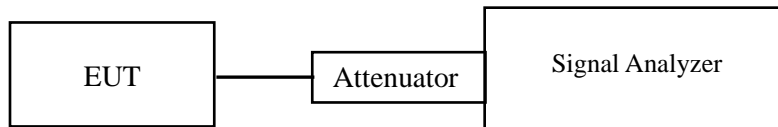

### Test Data

#### Environmental Conditions

<b>Temperature:</b>	27 °C
<b>Relative Humidity:</b>	54 %
<b>ATM Pressure:</b>	101.0 kPa

*The testing was performed by Cary Guan on 2020-03-06.*

*EUT operation mode: Transmitting*

Test Result: Compliant. Please refer to the Appendix.

## FCC §15.247(e) - POWER SPECTRAL DENSITY

### Applicable Standard

For digitally modulated systems, the power spectral density conducted from the intentional radiator to the antenna shall not be greater than 8 dBm in any 3 kHz band during any time interval of continuous transmission. This power spectral density shall be determined in accordance with the provisions of paragraph (b) of this section. The same method of determining the conducted output power shall be used to determine the power spectral density.

### Test Procedure

1. Use this procedure when the maximum peak conducted output power in the fundamental emission is used to demonstrate compliance.
2. Set the RBW to:  $3\text{kHz} \leq \text{RBW} \leq 100\text{ kHz}$ .
3. Set the VBW  $\geq 3 \times \text{RBW}$ .
4. Set the span to 1.5 times the DTS bandwidth.
5. Detector = peak.
6. Sweep time = auto couple.
7. Trace mode = max hold.
8. Allow trace to fully stabilize.
9. Use the peak marker function to determine the maximum amplitude level within the RBW.
10. If measured value exceeds limit, reduce RBW (no less than 3 kHz) and repeat.

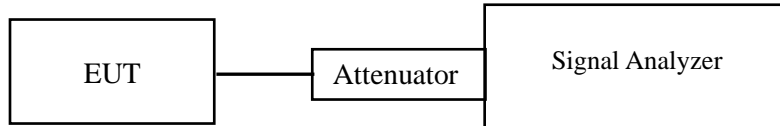

### Test Data

#### Environmental Conditions

<b>Temperature:</b>	27 °C
<b>Relative Humidity:</b>	54 %
<b>ATM Pressure:</b>	101.0 kPa

*The testing was performed by Cary Guan on 2020-03-06.*

*EUT operation mode: Transmitting*

Test Result: Compliant. Please refer to the Appendix.



**APPENDIX****Appendix A: DTS Bandwidth  
Test Result**

Test Mode	Antenna	Channel	DTS BW [MHz]	Limit[MHz]	Verdict
11B	Ant1	2412	10.160	0.5	PASS
		2442	10.160	0.5	PASS
		2472	10.160	0.5	PASS
11G	Ant1	2412	16.400	0.5	PASS
		2442	16.400	0.5	PASS
		2472	16.440	0.5	PASS
11N20	Ant1	2412	17.200	0.5	PASS
		2442	17.160	0.5	PASS
		2472	17.160	0.5	PASS
11N40	Ant1	2422	36.240	0.5	PASS
		2442	36.160	0.5	PASS
		2462	36.480	0.5	PASS

Test Graphs

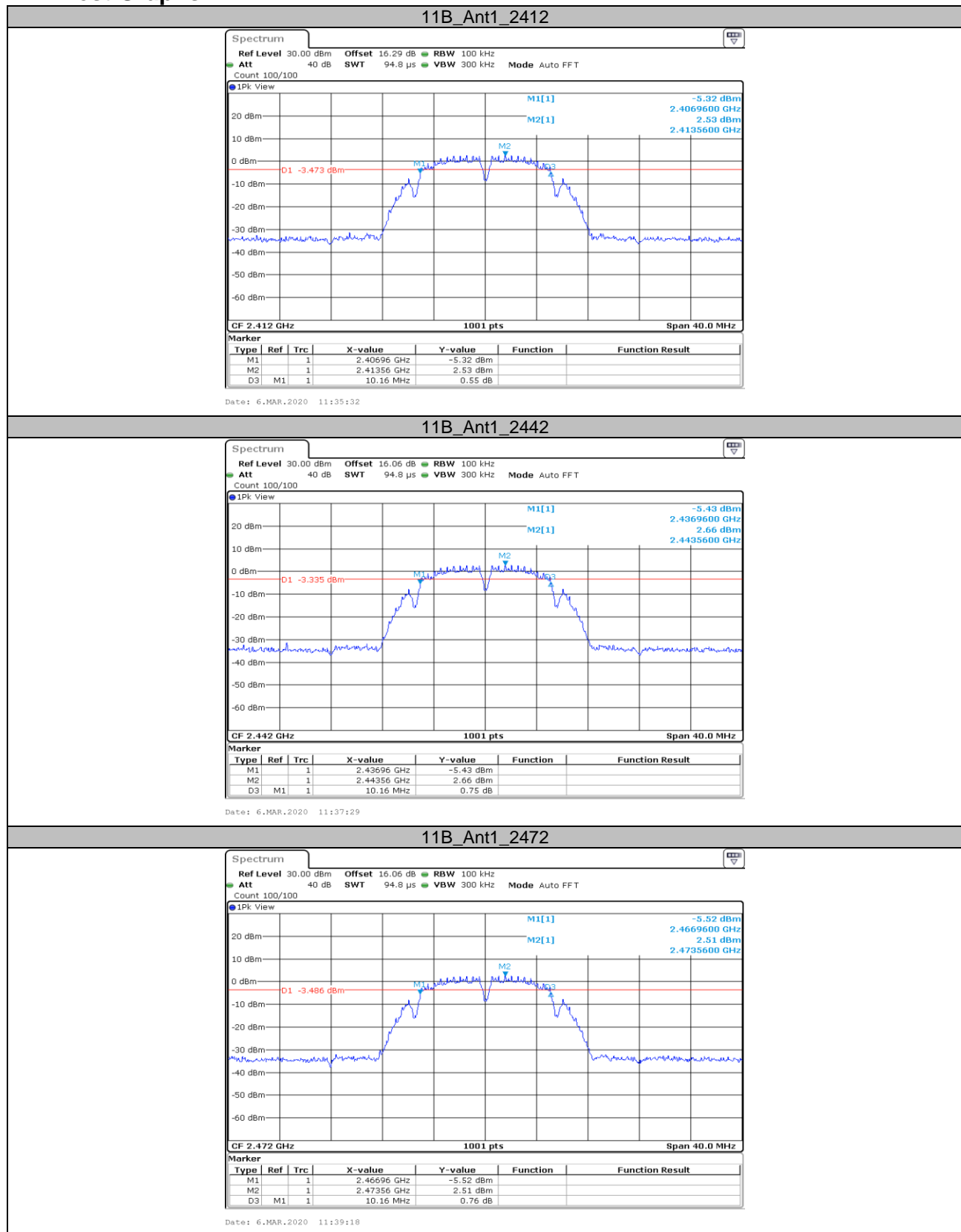

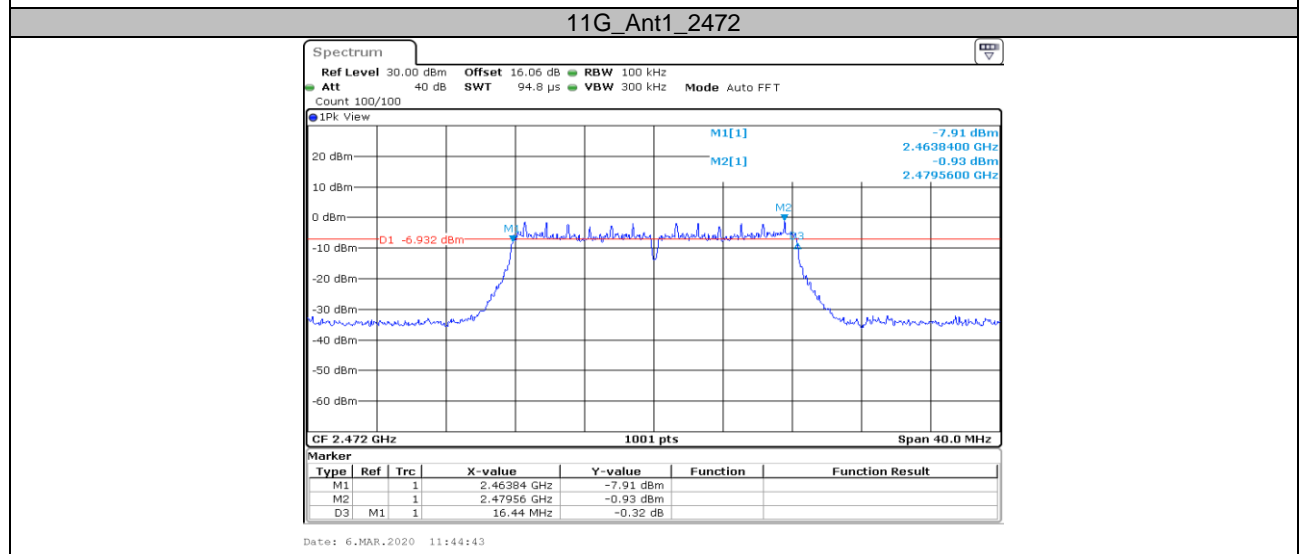
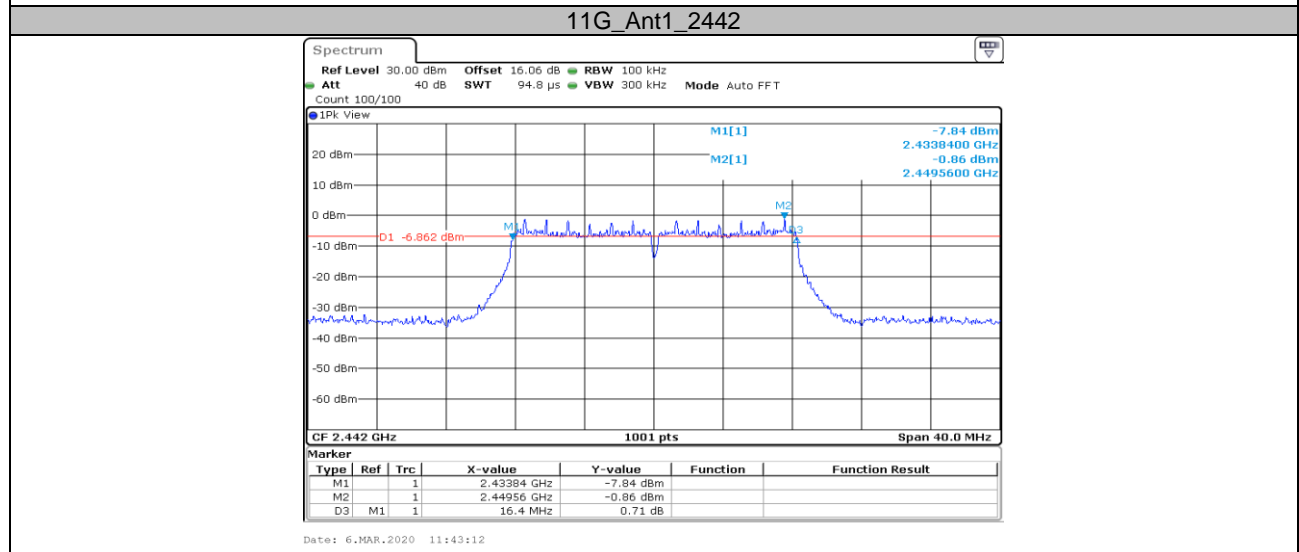
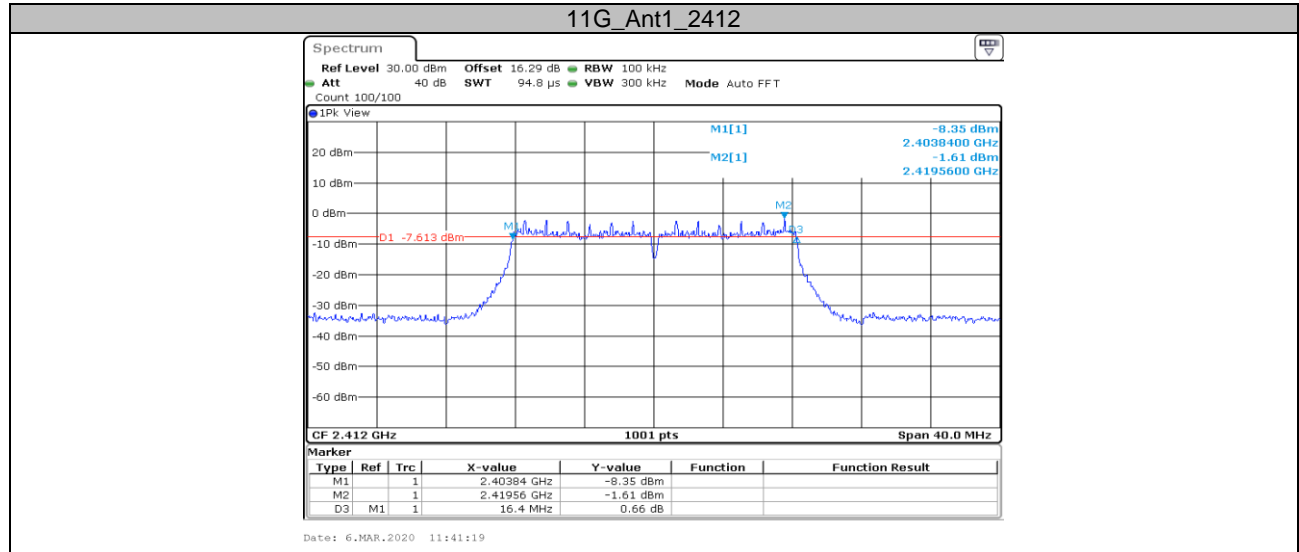

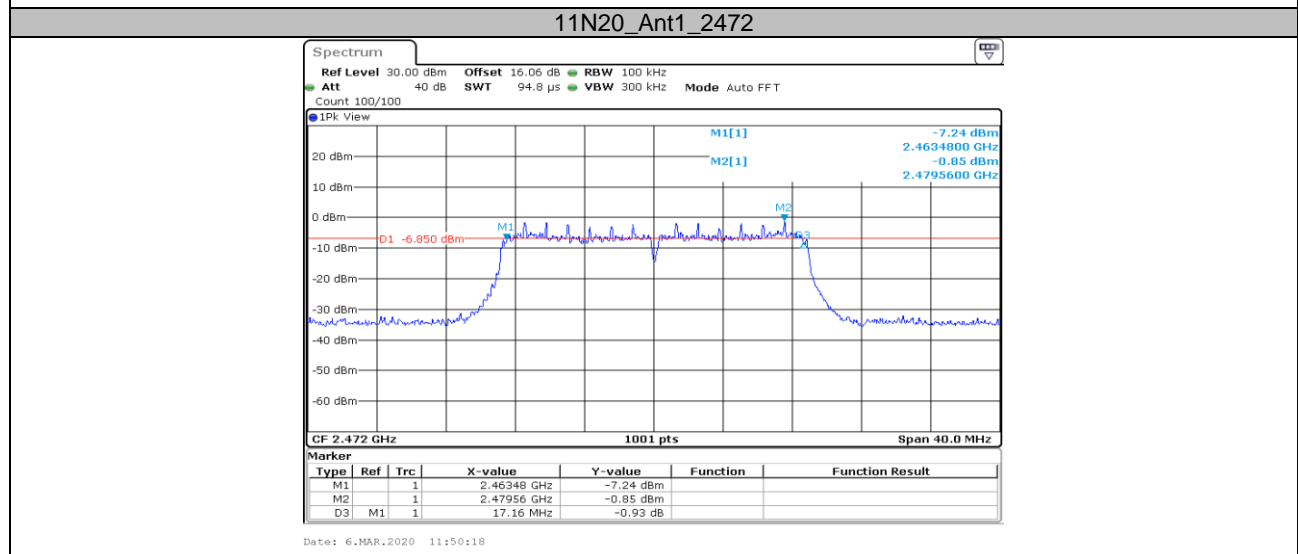
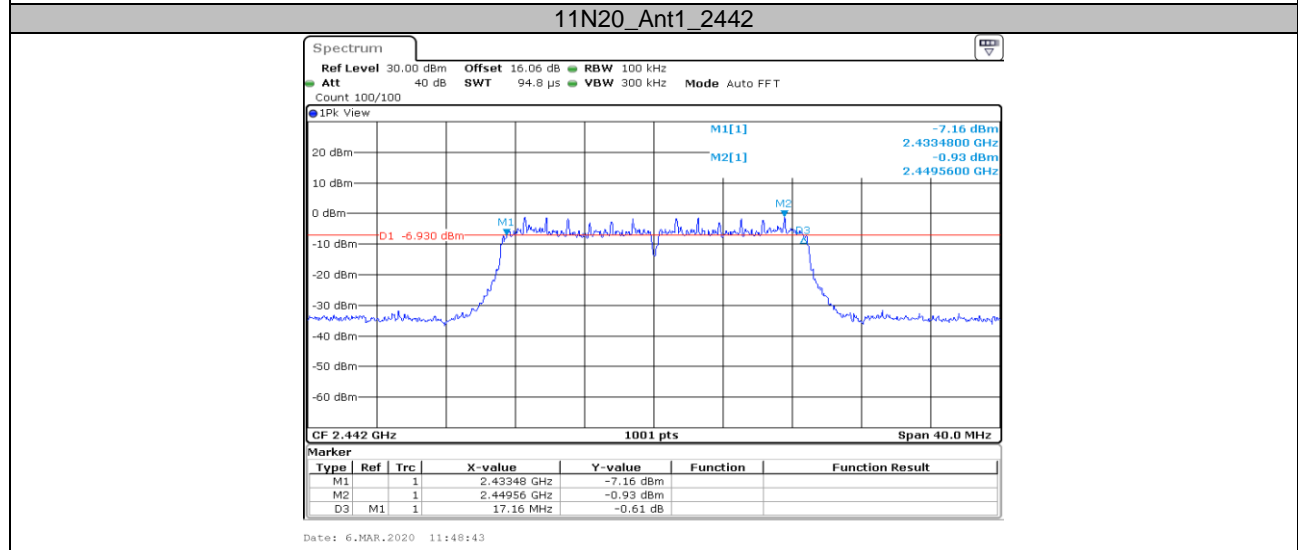
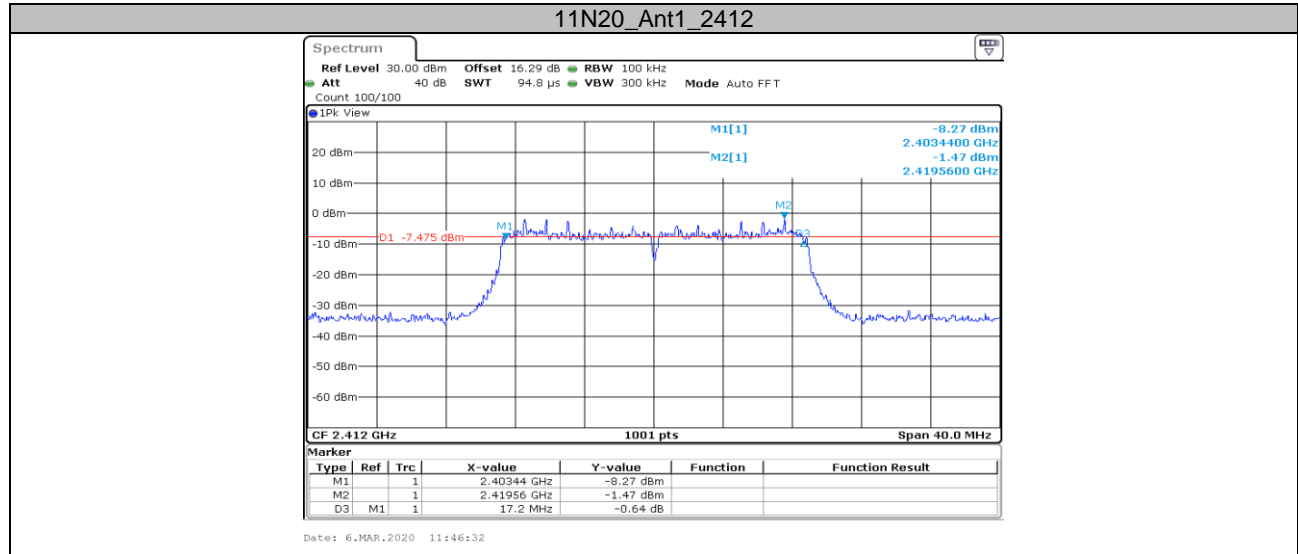

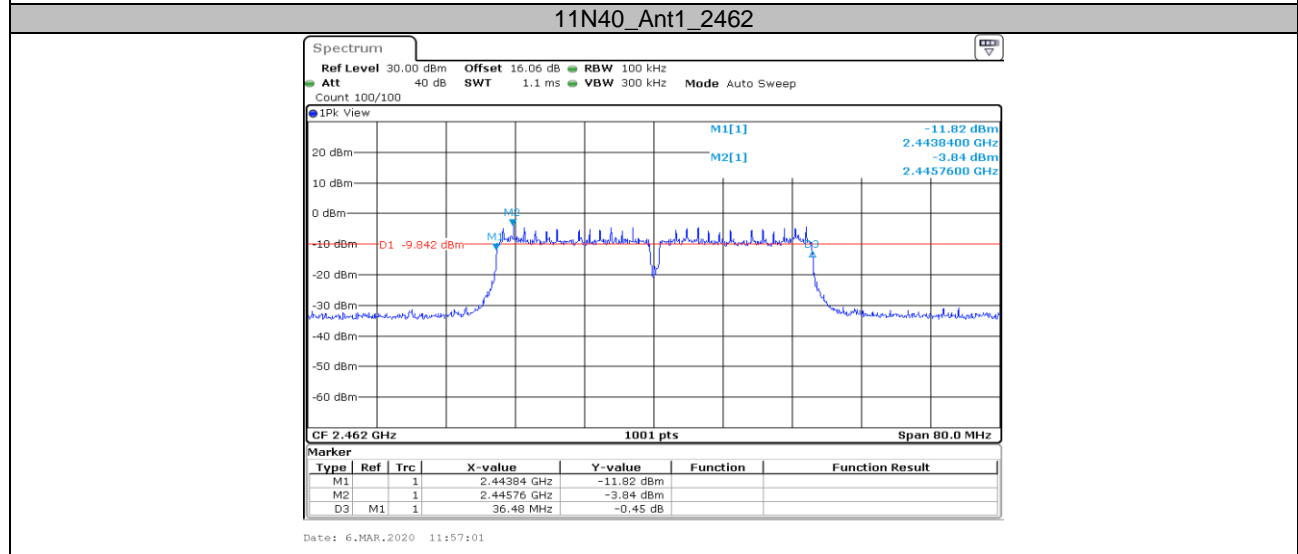
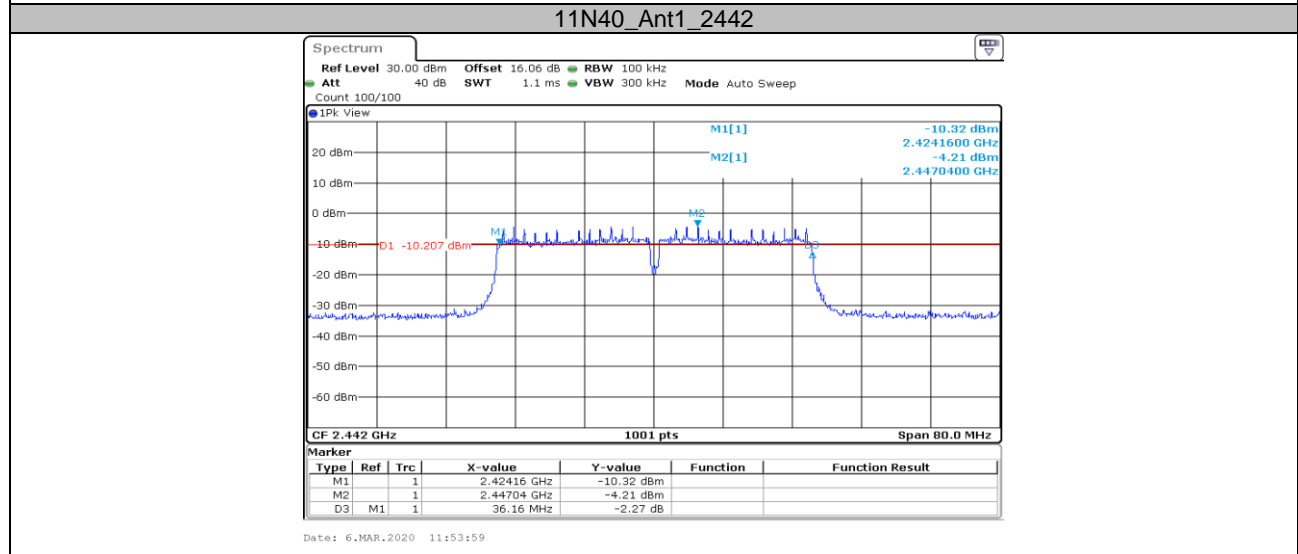
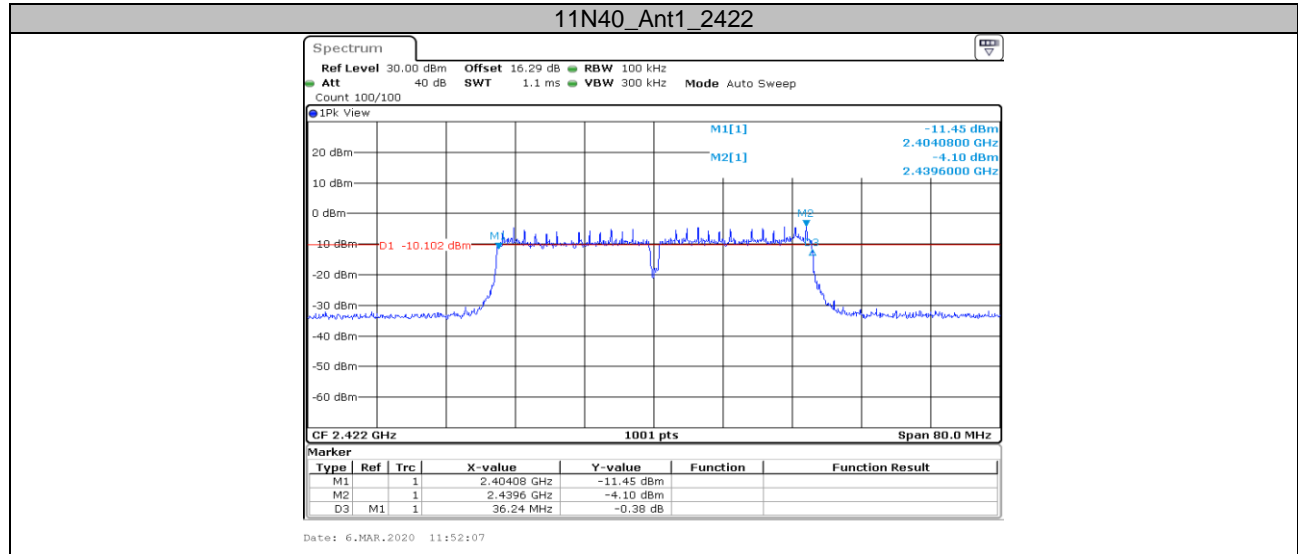

**Appendix B: Occupied Channel Bandwidth  
Test Result**

Test Mode	Antenna	Channel	OCB [MHz]	Limit[MHz]	Verdict
11B	Ant1	2412	12.867	---	PASS
		2442	12.787	---	PASS
		2472	12.867	---	PASS
11G	Ant1	2412	17.542	---	PASS
		2442	17.423	---	PASS
		2472	17.502	---	PASS
11N20	Ant1	2412	18.182	---	PASS
		2442	18.142	---	PASS
		2472	18.182	---	PASS
11N40	Ant1	2422	37.243	---	PASS
		2442	37.083	---	PASS
		2462	37.243	---	PASS

Test Graphs

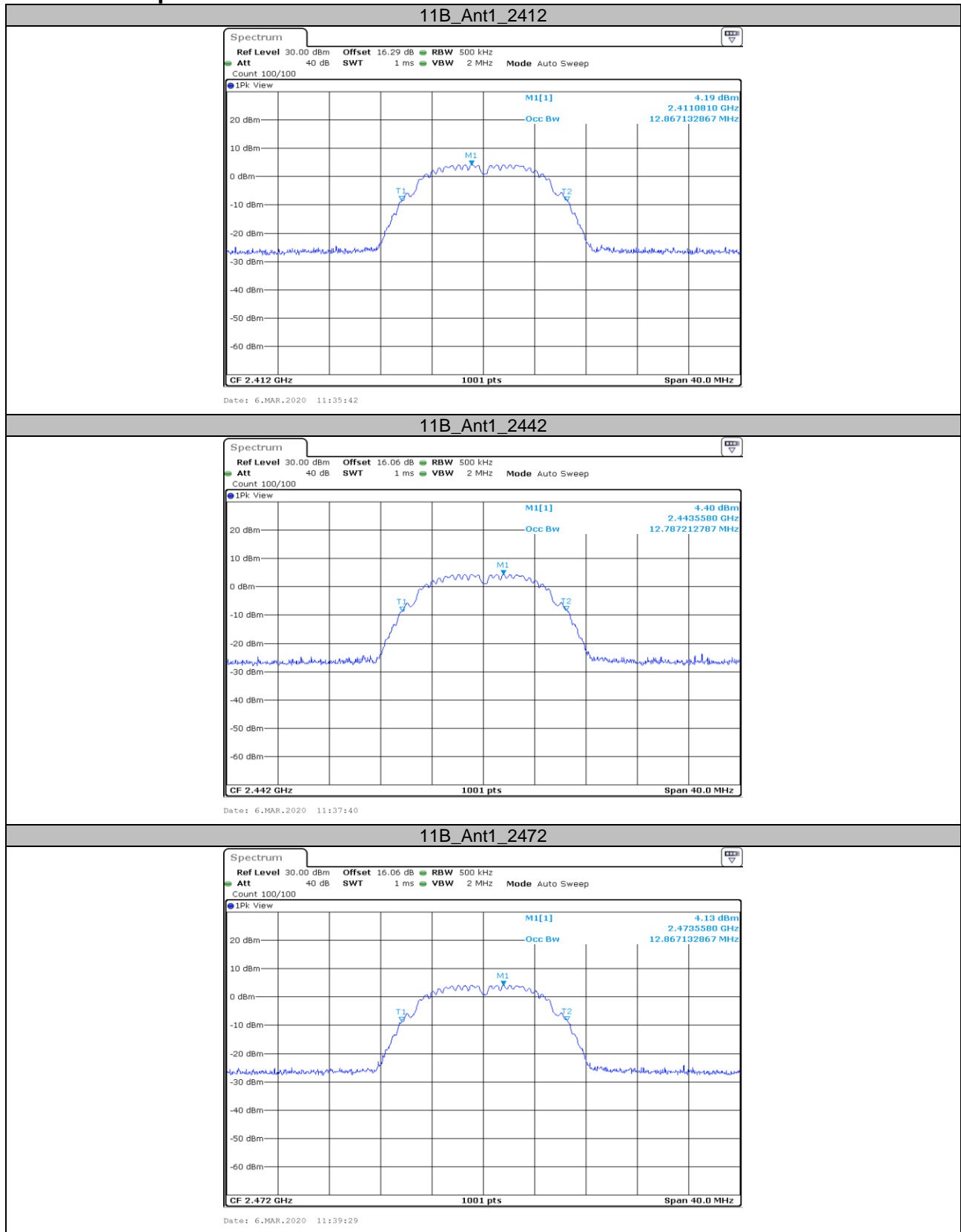

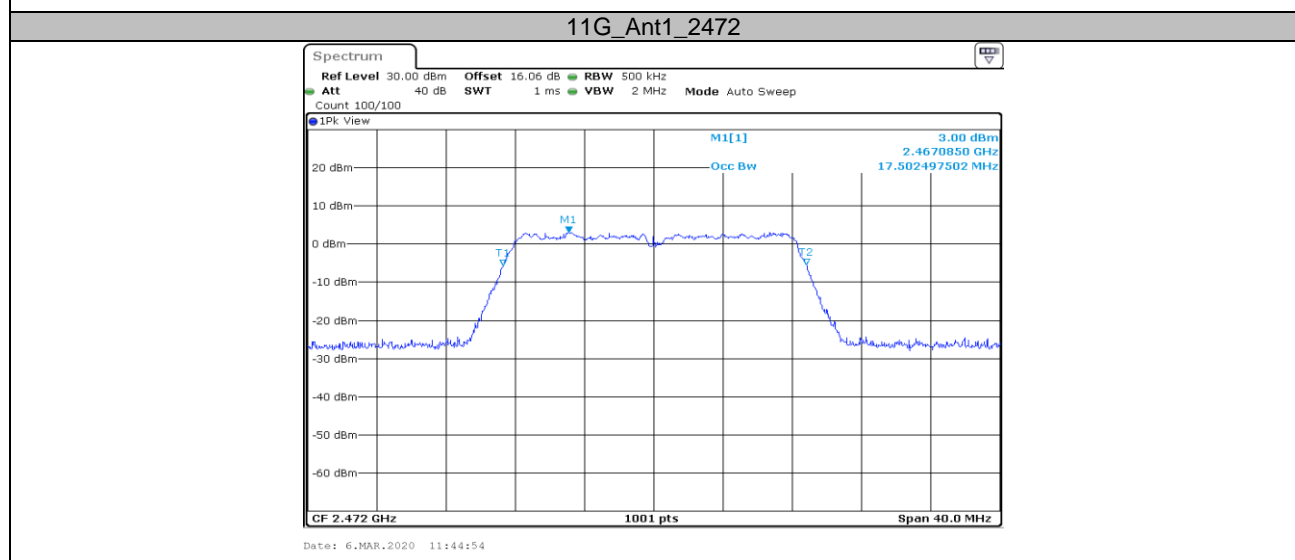
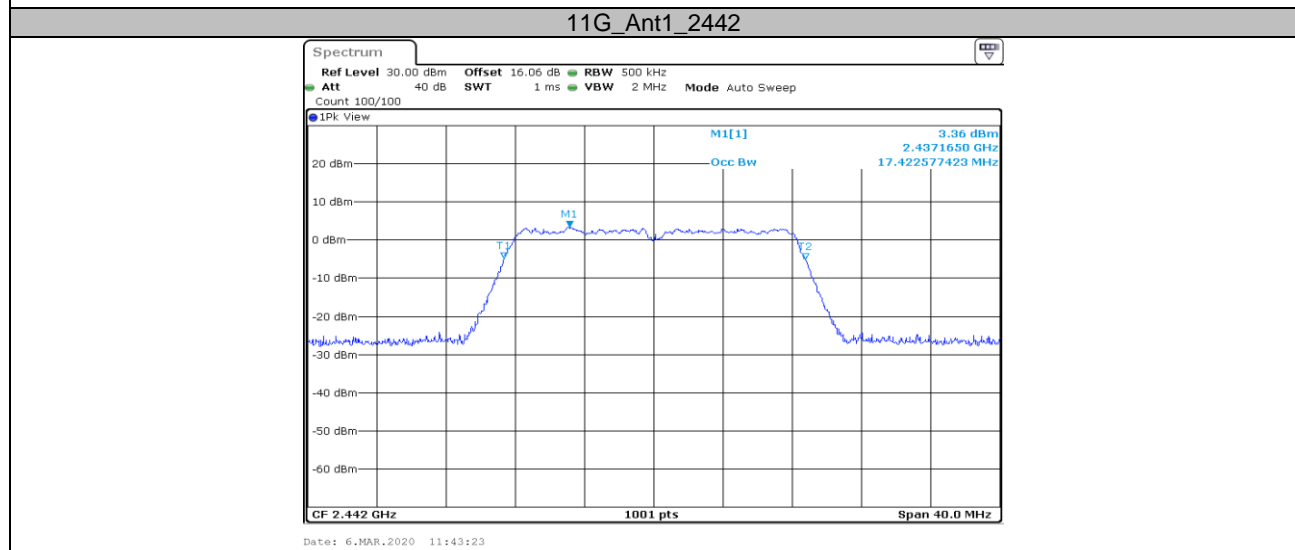
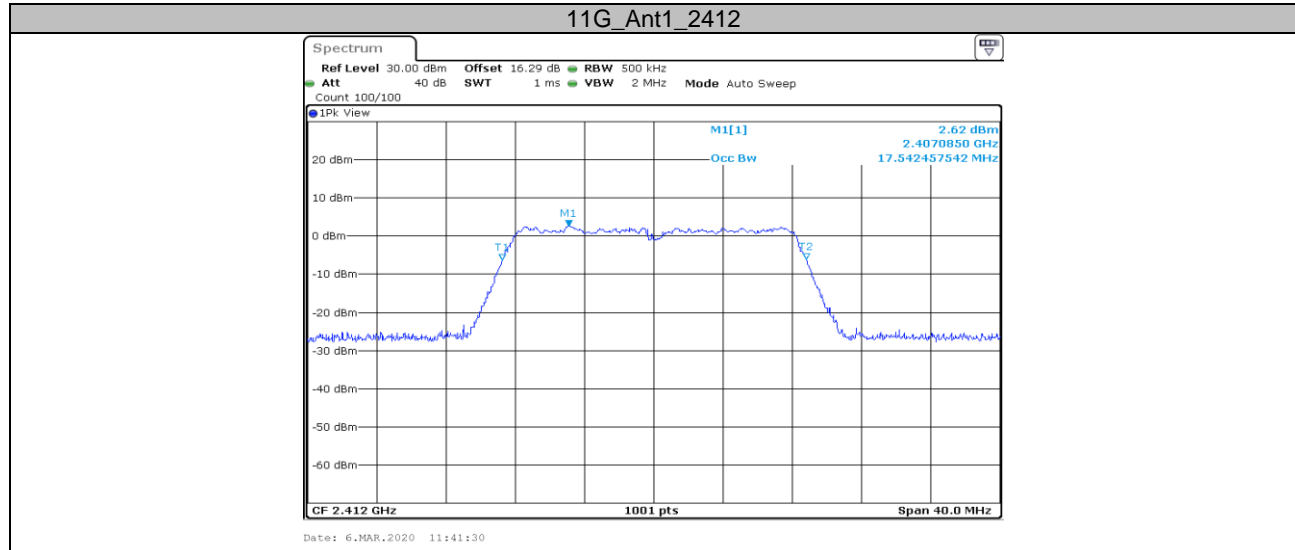



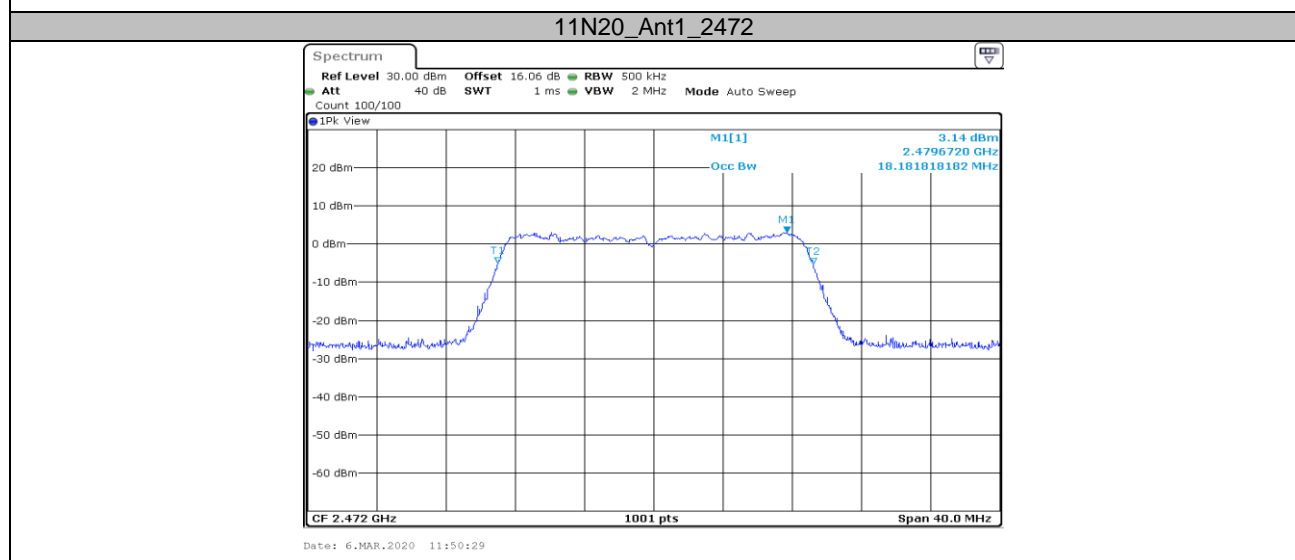
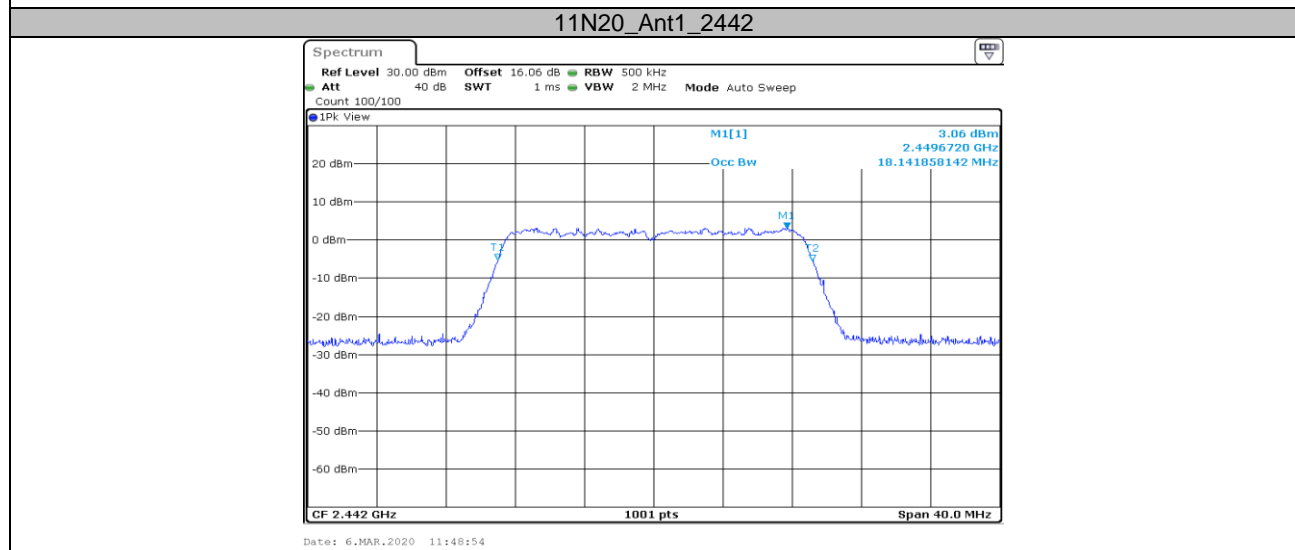
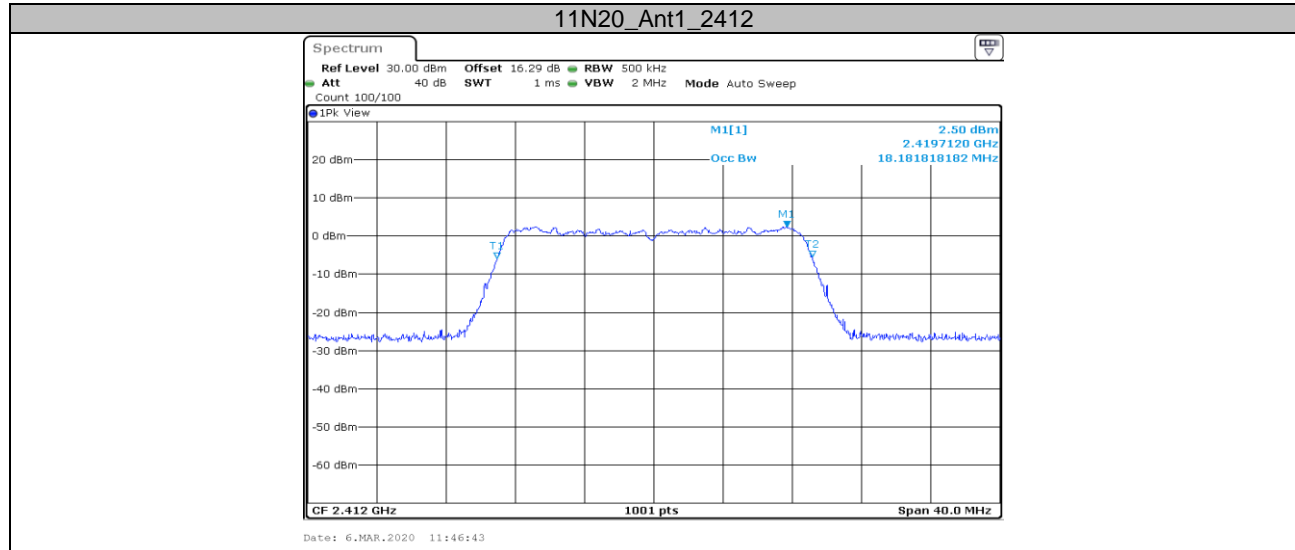

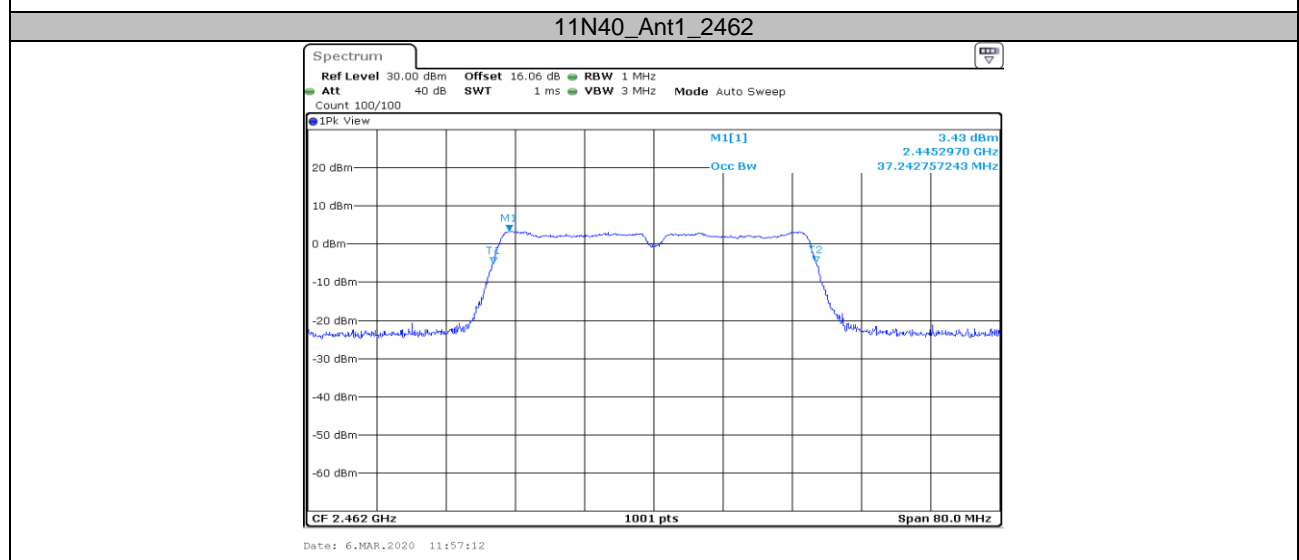
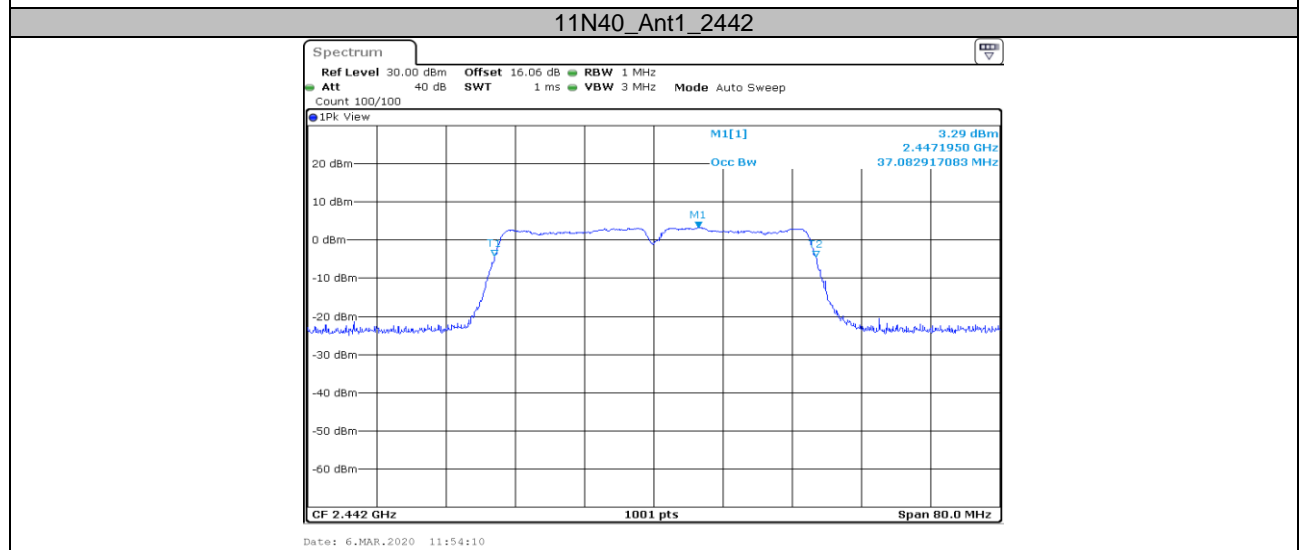
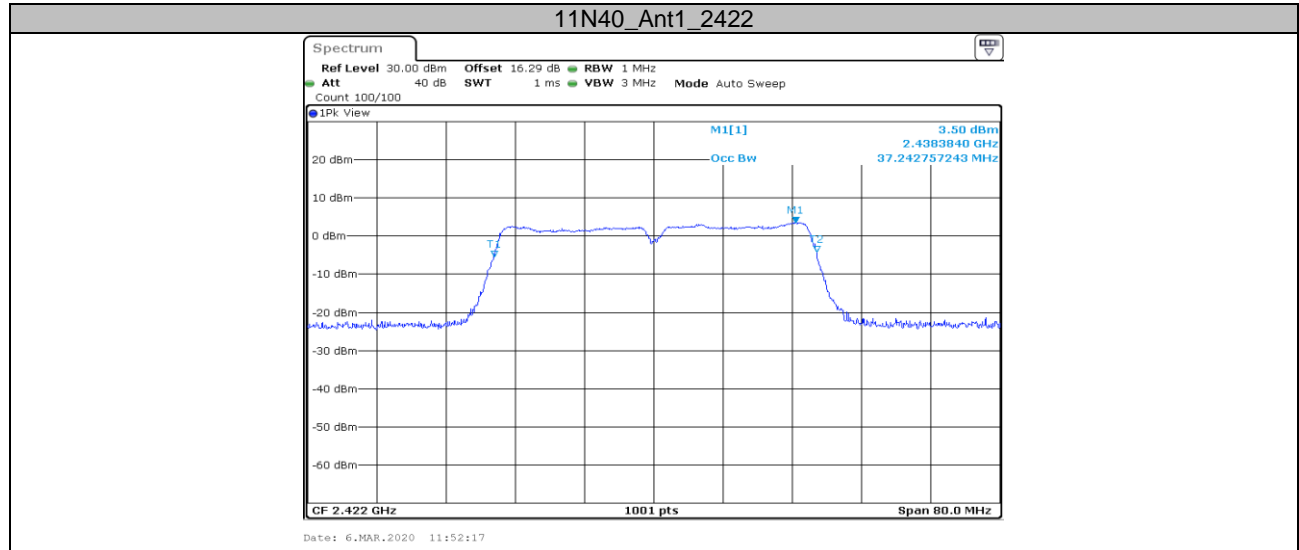

**Appendix C: Maximum conducted peak output power  
Test Result**

Test Mode	Antenna	Channel	Result[dBm]	Limit[dBm]	Verdict
11B	Ant1	2412	15.91	<=30	PASS
		2442	16.05	<=30	PASS
		2472	15.81	<=30	PASS
11G	Ant1	2412	17.13	<=30	PASS
		2442	17.95	<=30	PASS
		2472	17.64	<=30	PASS
11N20	Ant1	2412	17.11	<=30	PASS
		2442	17.90	<=30	PASS
		2472	17.60	<=30	PASS
11N40	Ant1	2422	17.22	<=30	PASS
		2442	17.52	<=30	PASS
		2462	17.47	<=30	PASS

**Appendix D: Maximum power spectral density  
Test Result**

Test Mode	Antenna	Channel	Result[dBm/3kHz]	Limit[dBm/3kHz]	Verdict
11B	Ant1	2412	1.55	<=8	PASS
		2442	1.77	<=8	PASS
		2472	1.42	<=8	PASS
11G	Ant1	2412	-17.48	<=8	PASS
		2442	-16.38	<=8	PASS
		2472	-16.4	<=8	PASS
11N20	Ant1	2412	-16.77	<=8	PASS
		2442	-16.56	<=8	PASS
		2472	-15.85	<=8	PASS
11N40	Ant1	2422	-19.89	<=8	PASS
		2442	-19.49	<=8	PASS
		2462	-19.43	<=8	PASS

### Test Graphs

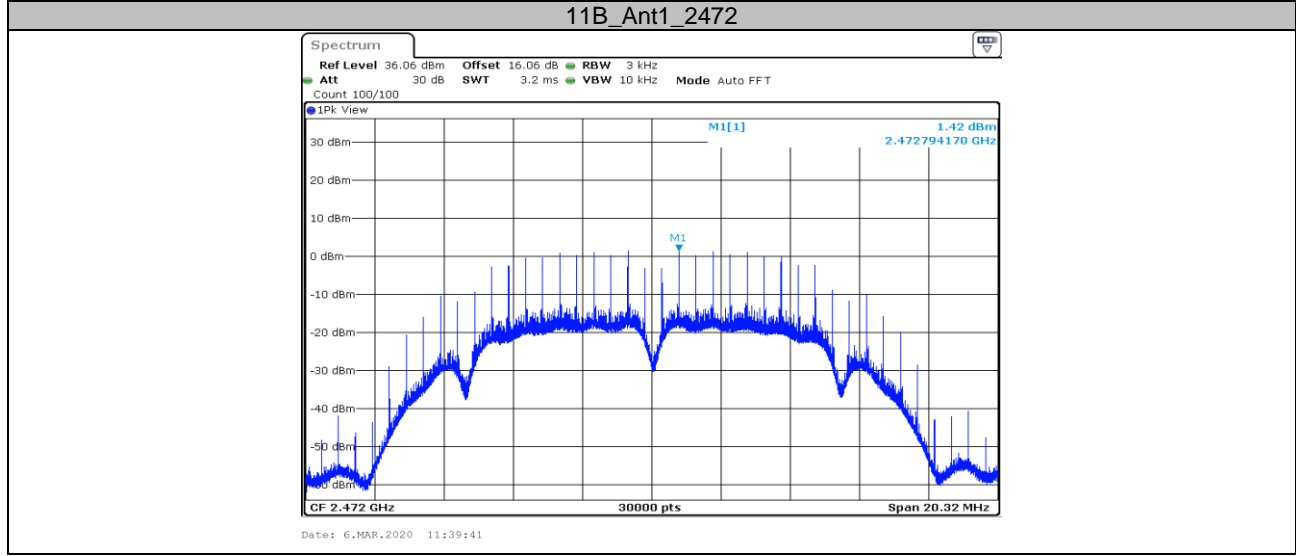
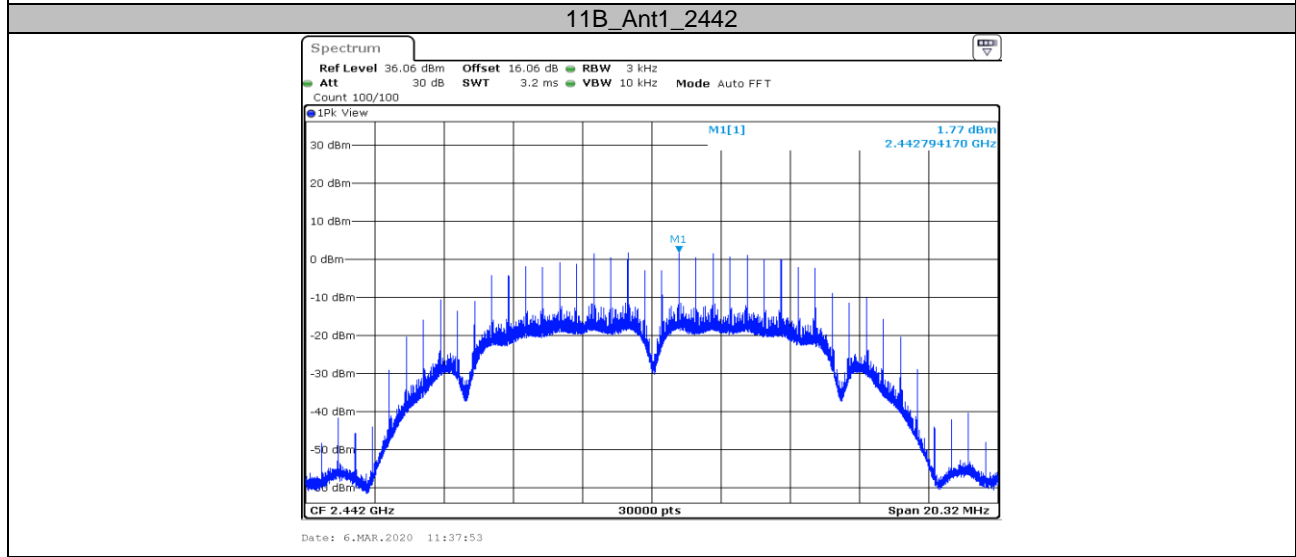
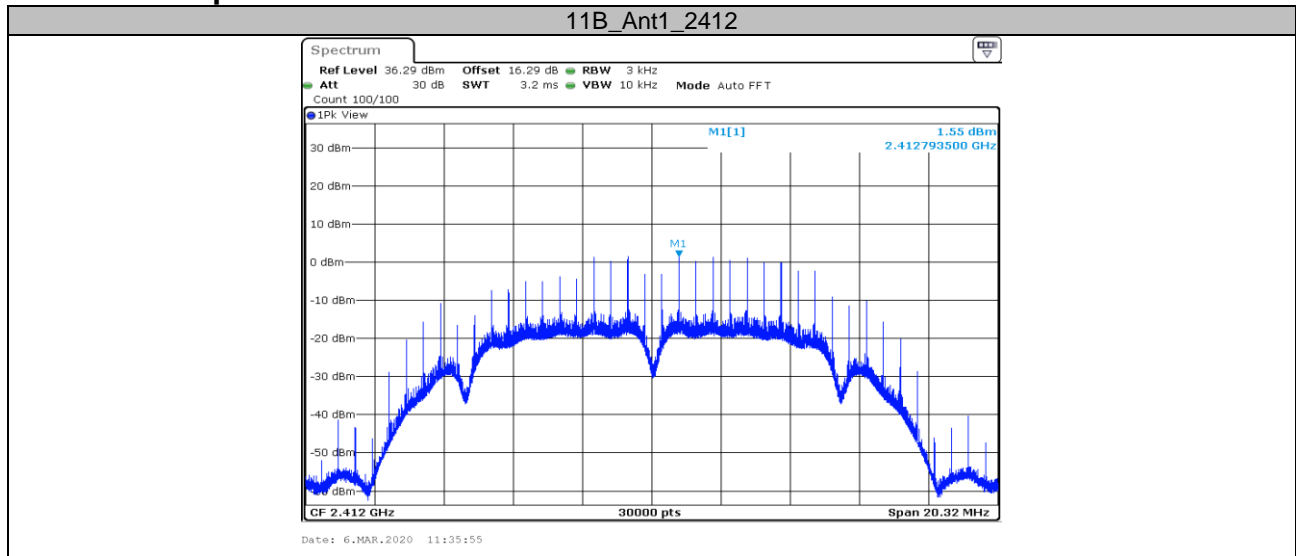

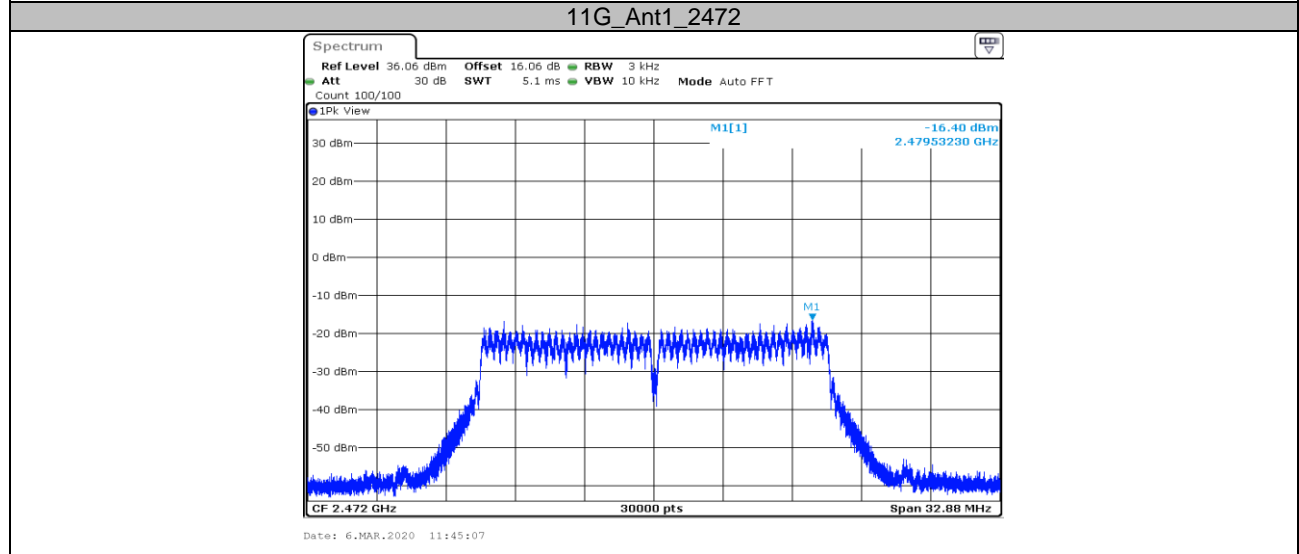
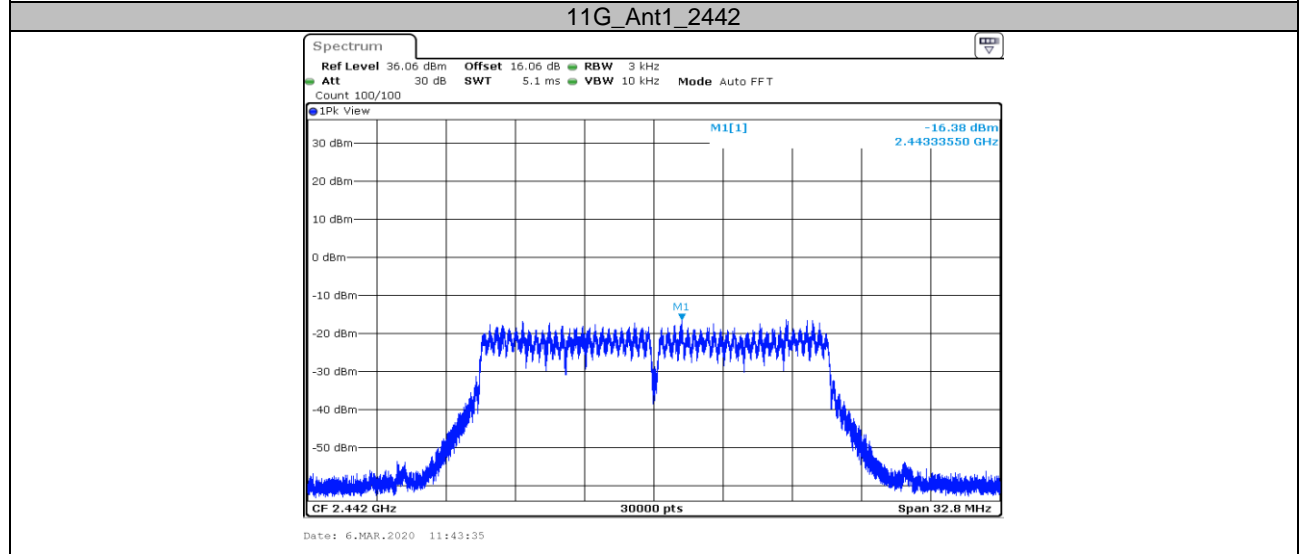
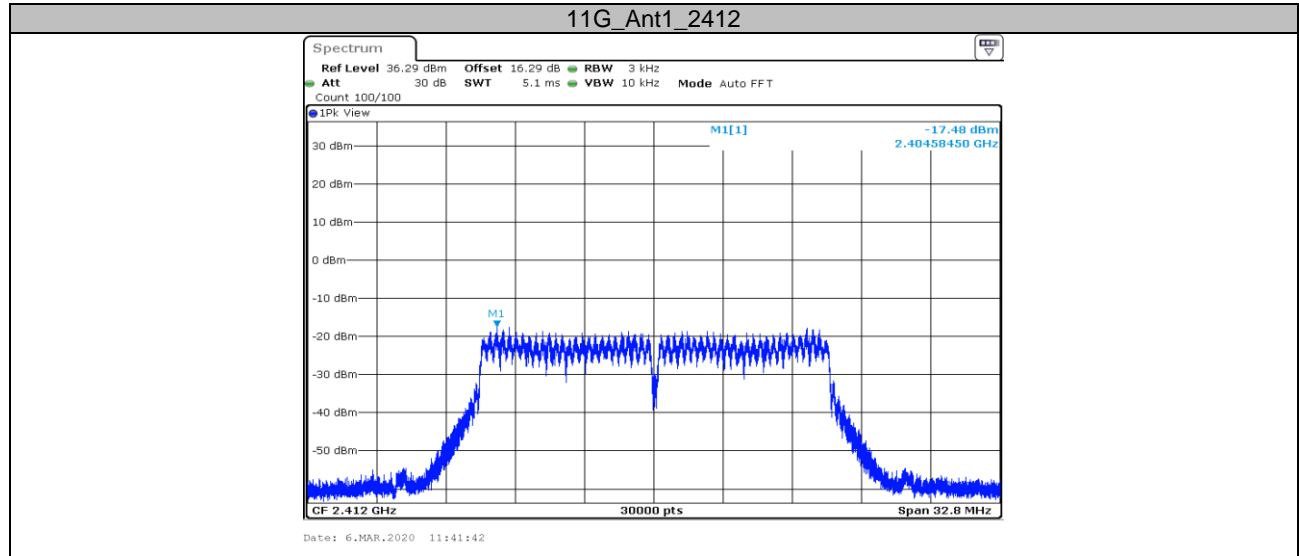

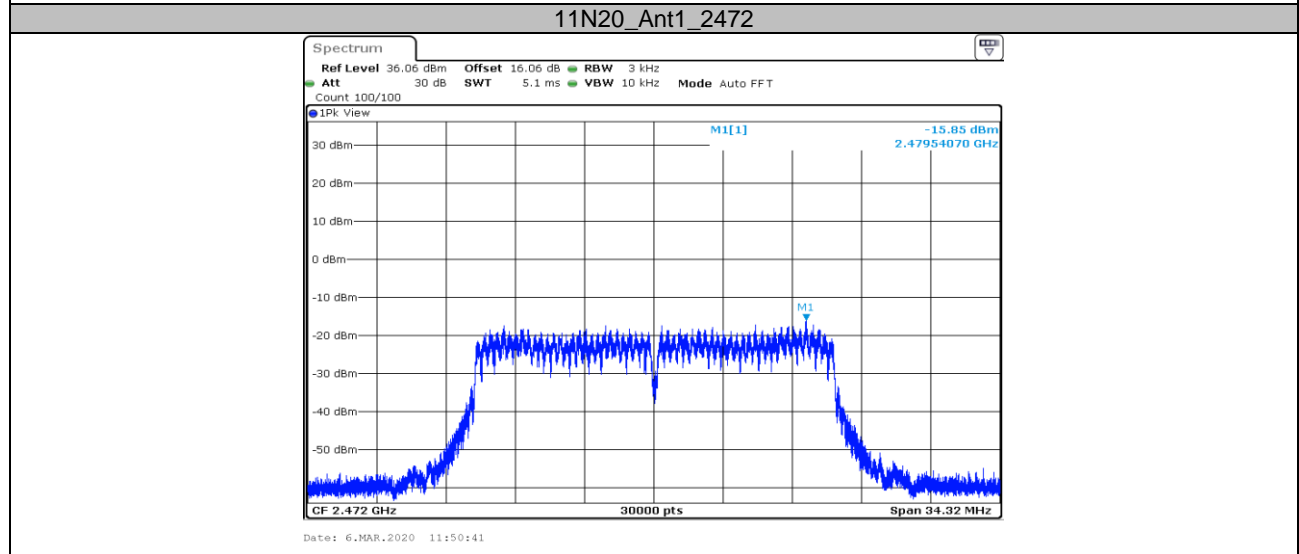
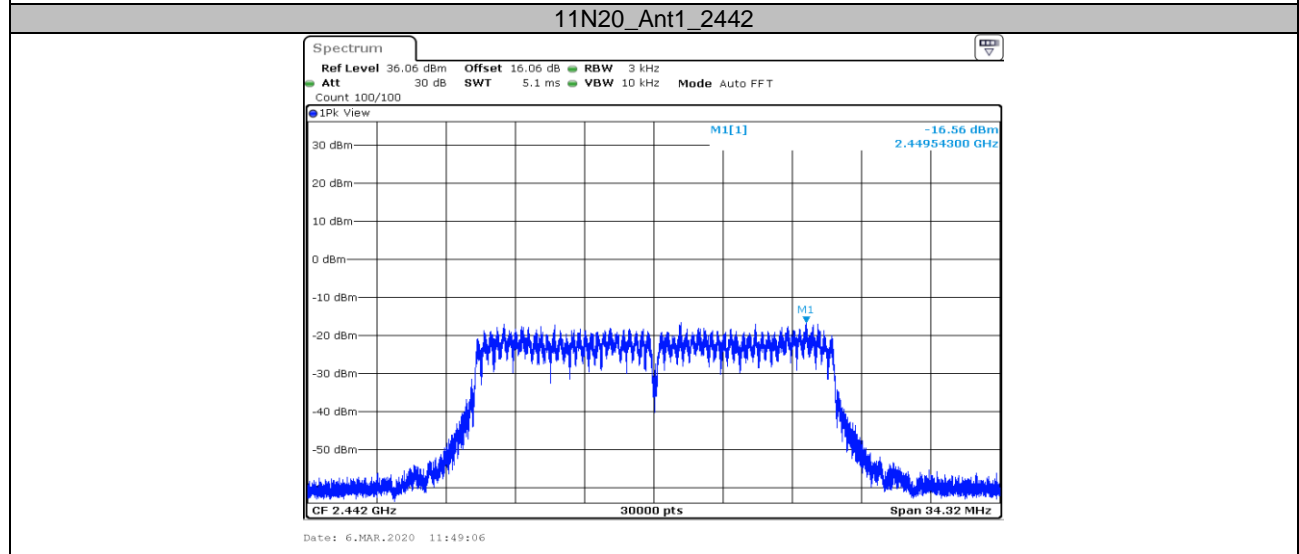
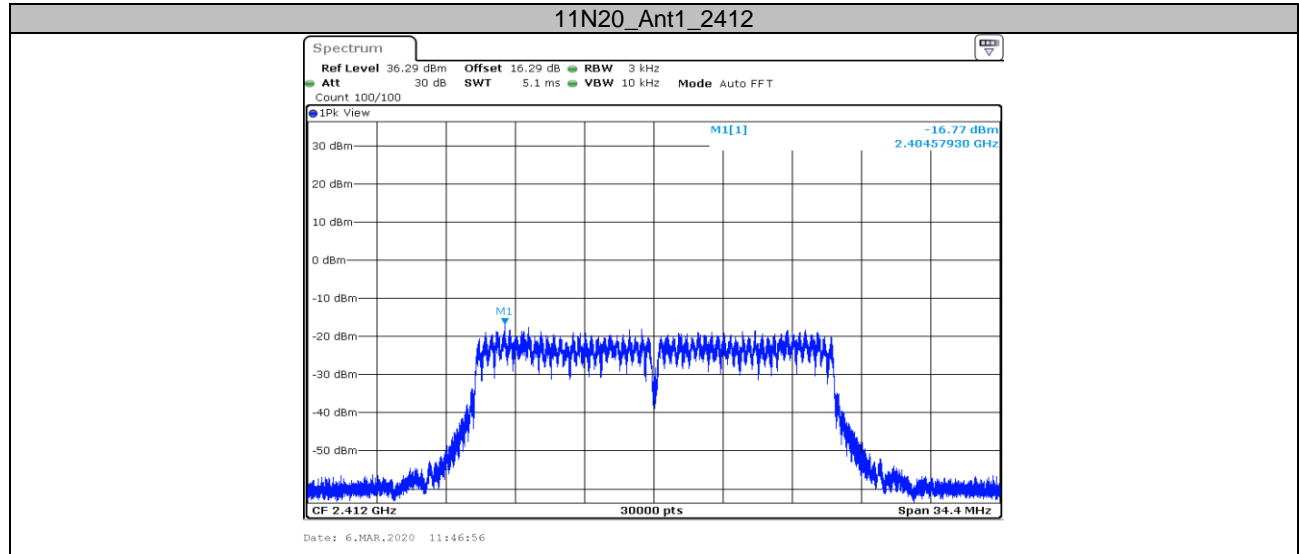

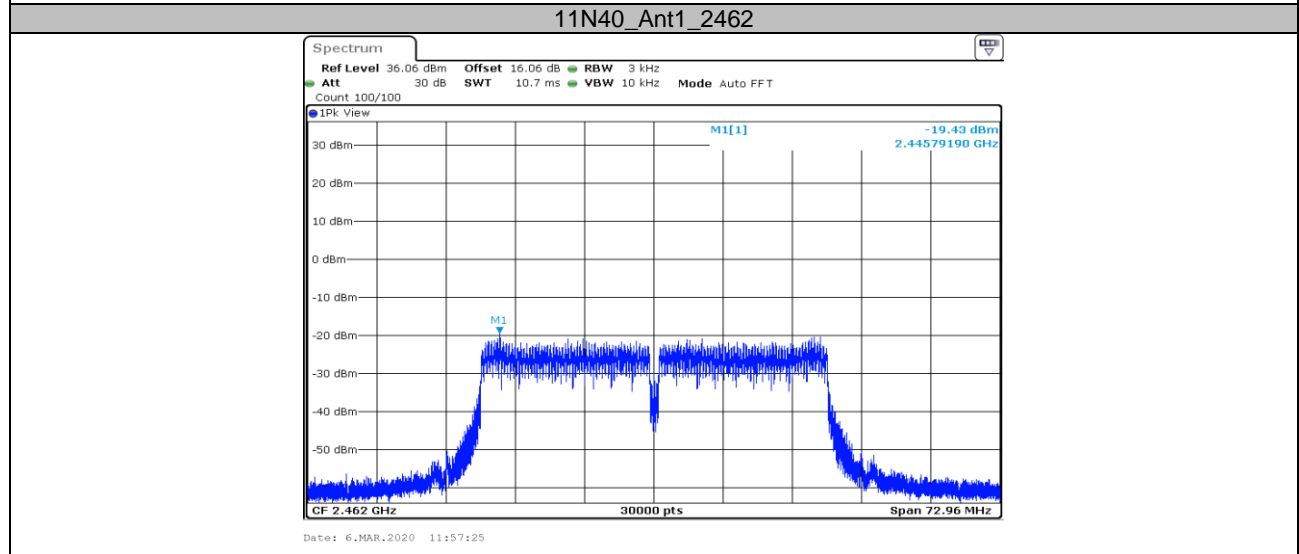
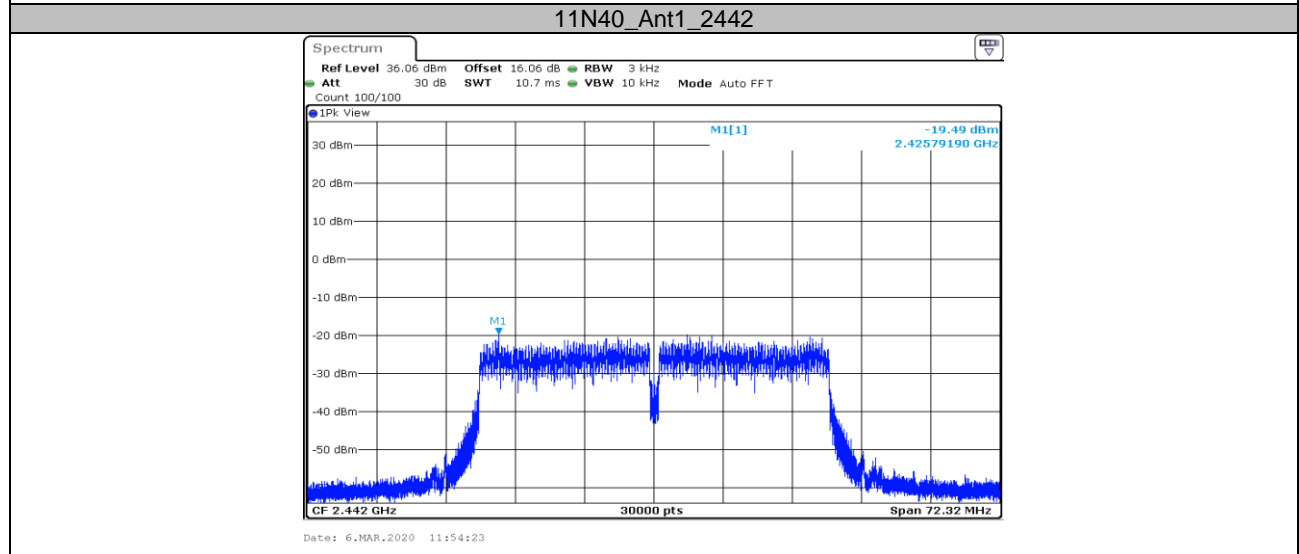
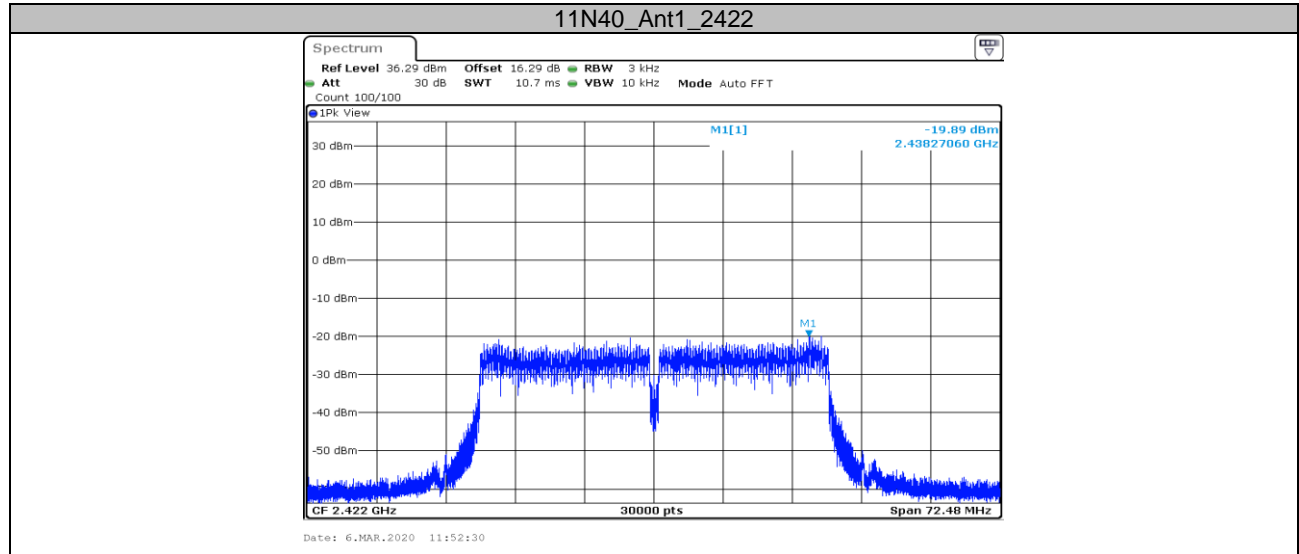



### Appendix E: Band edge measurements Test Graphs

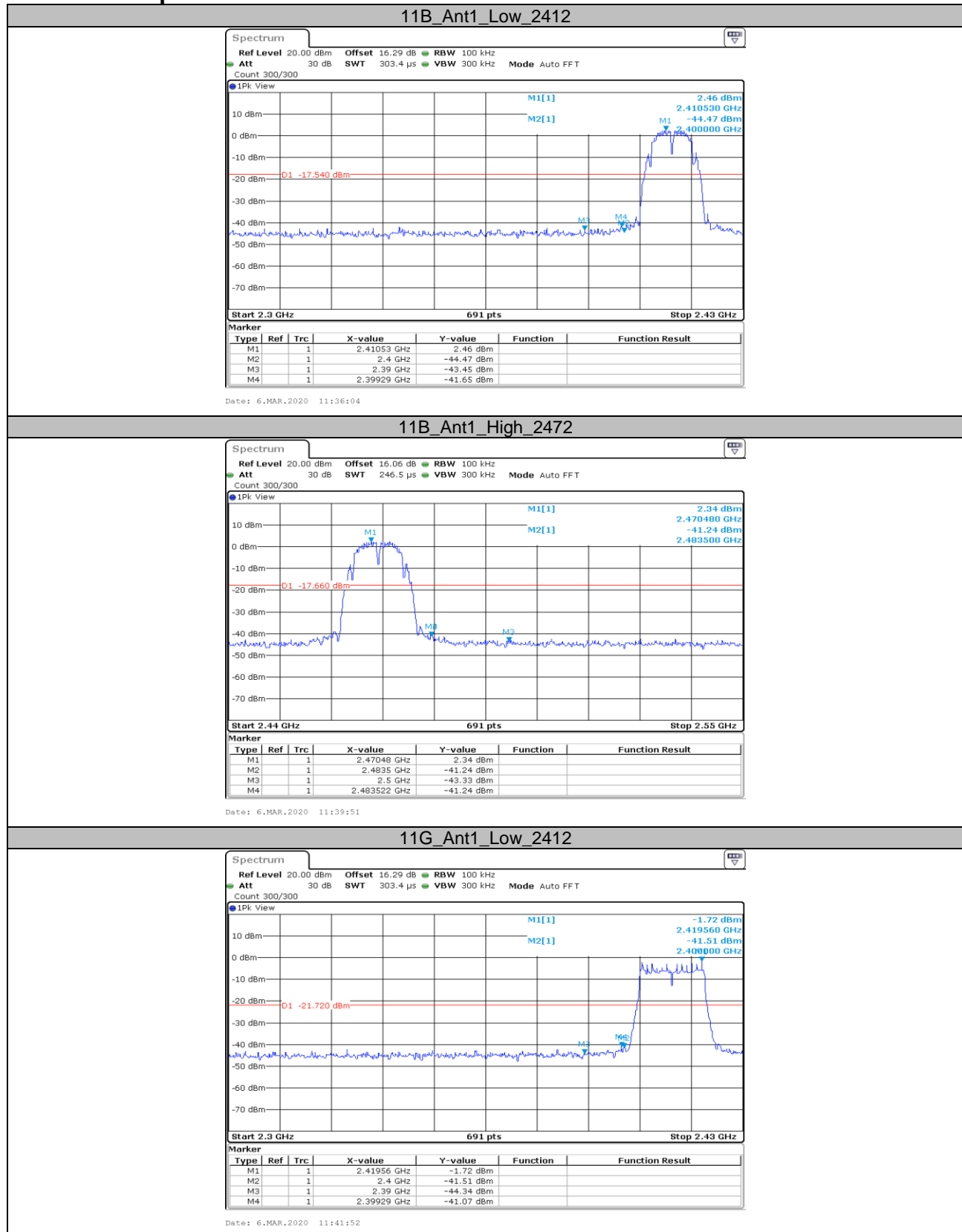

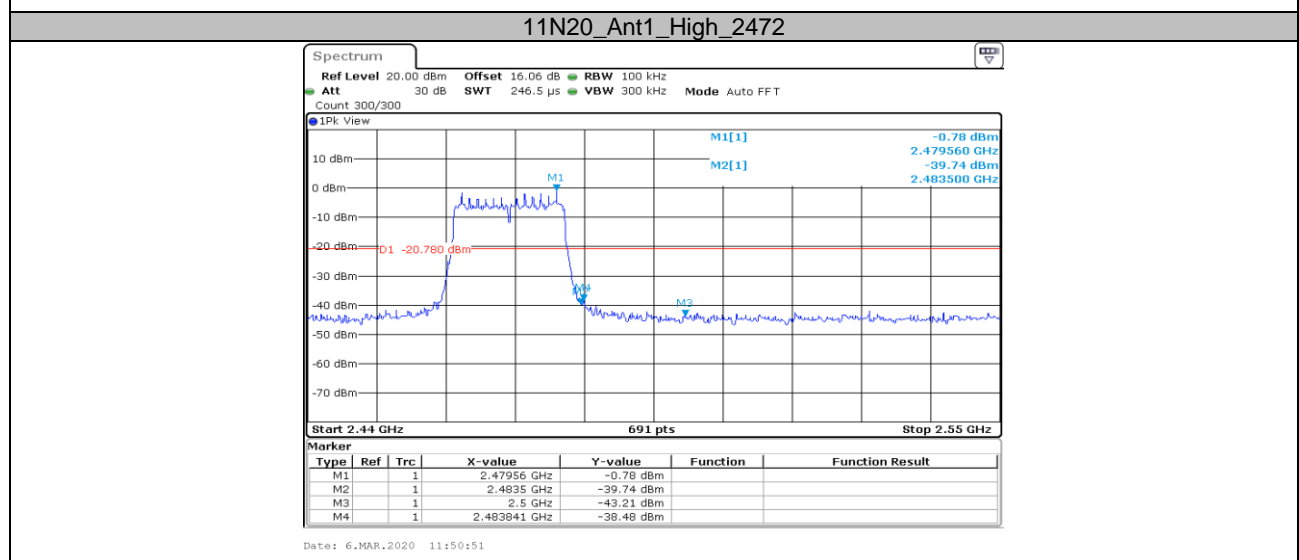
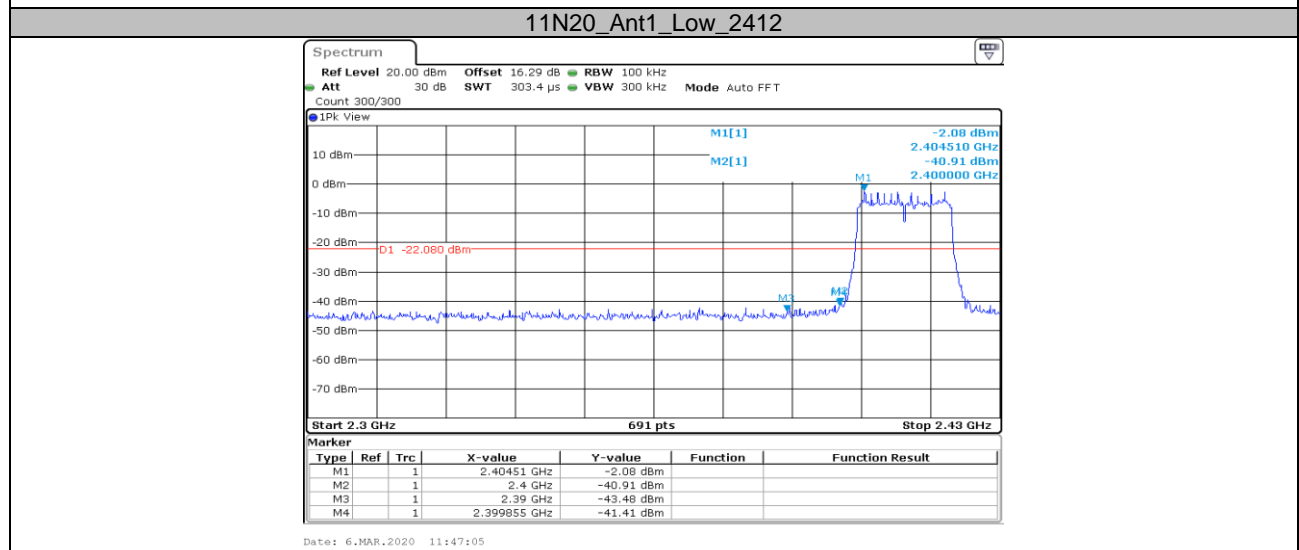
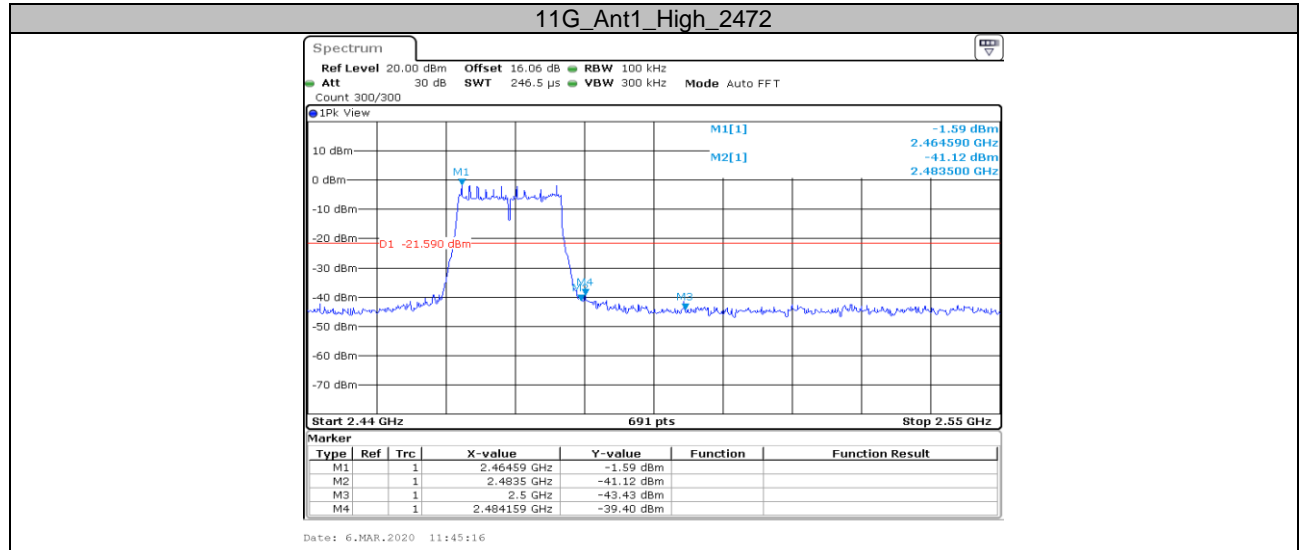

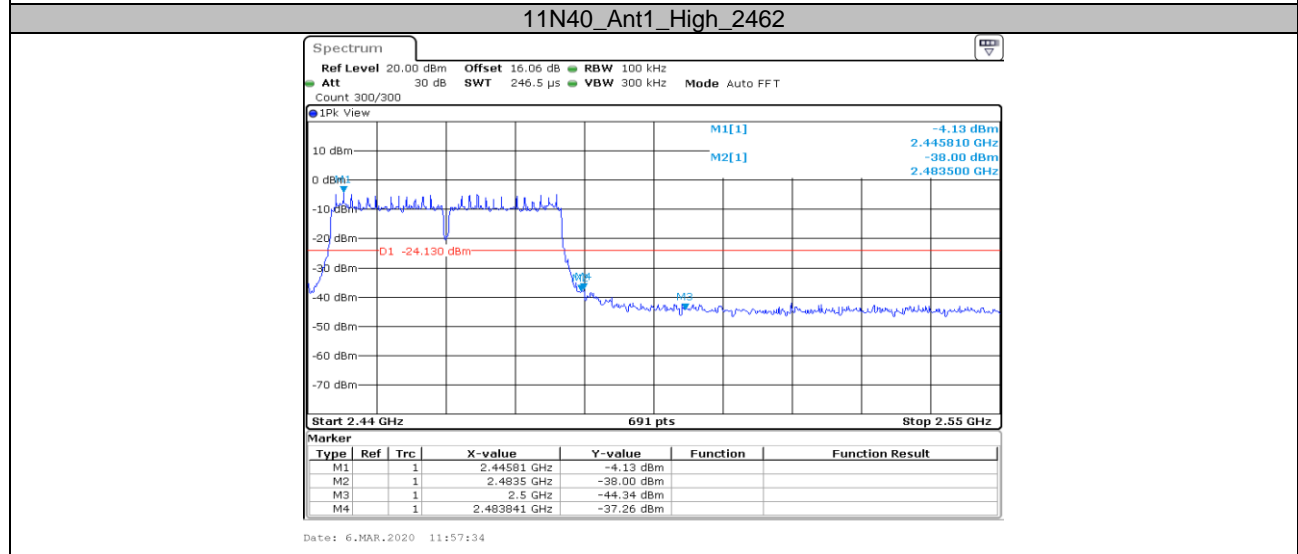
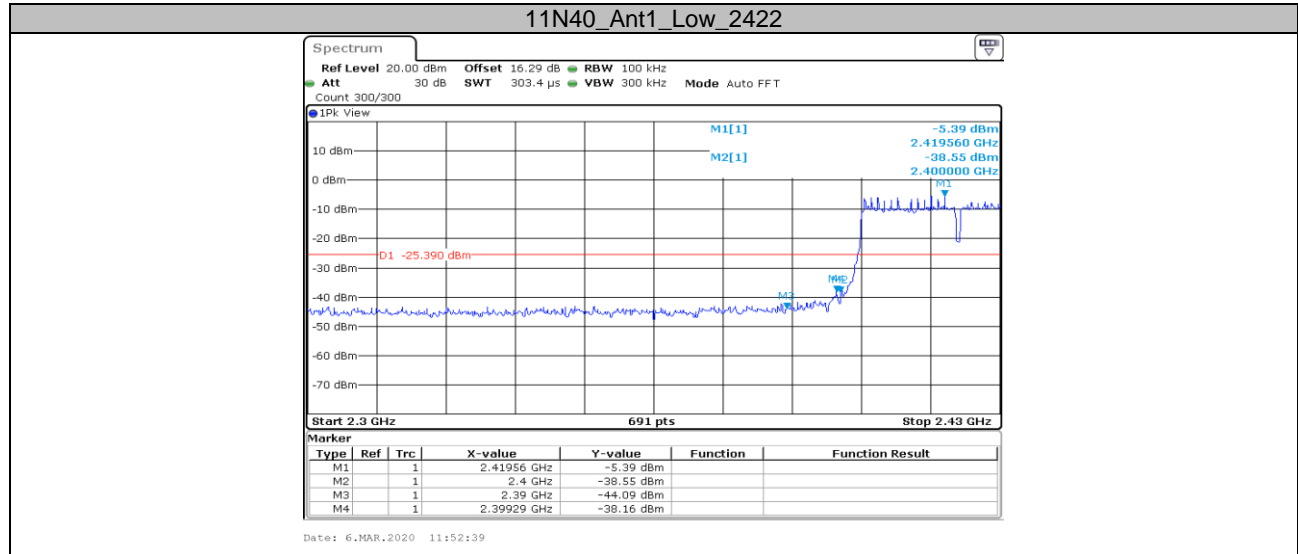

**Appendix G: Duty Cycle  
Test Result**

Test Mode	Antenna	Channel	Transmission Duration [ms]	Transmission Period [ms]	Duty Cycle [%]
11B	Ant1	2442	8.66	8.90	97.30
11G	Ant1	2442	1.42	1.64	86.59
11N20	Ant1	2442	1.33	1.55	85.81
11N40	Ant1	2442	0.65	0.87	74.71

Test Graphs

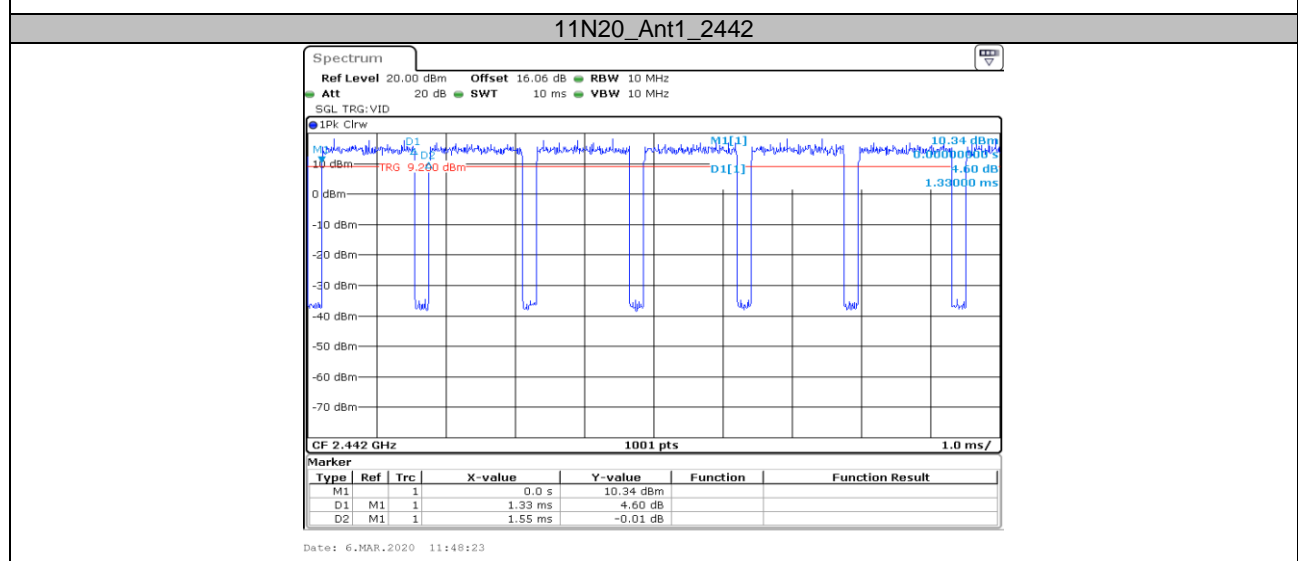
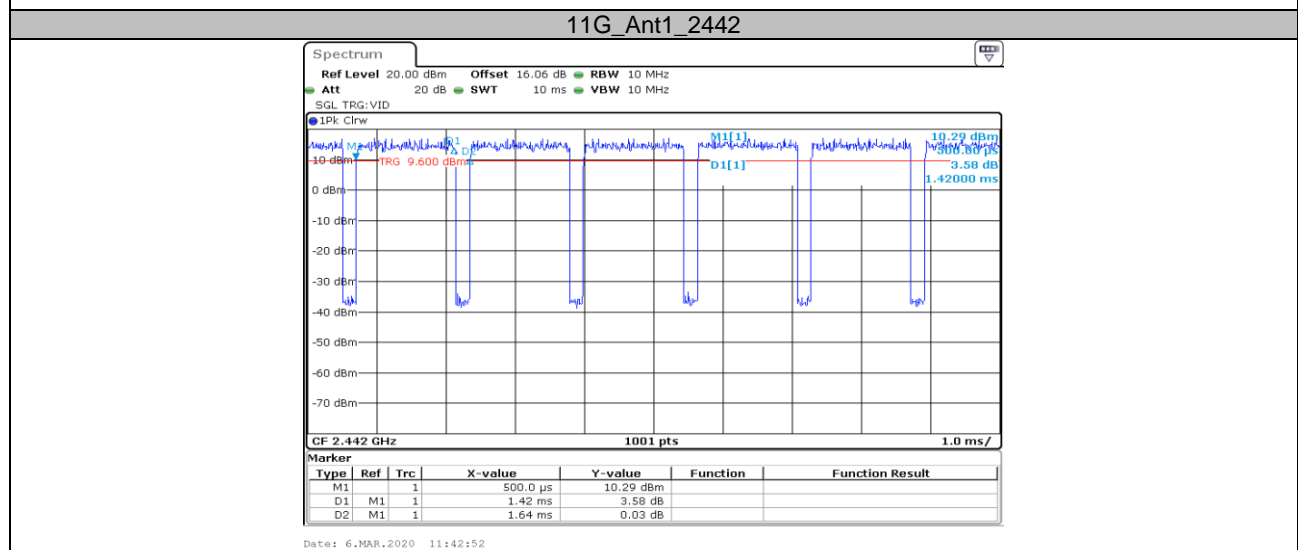
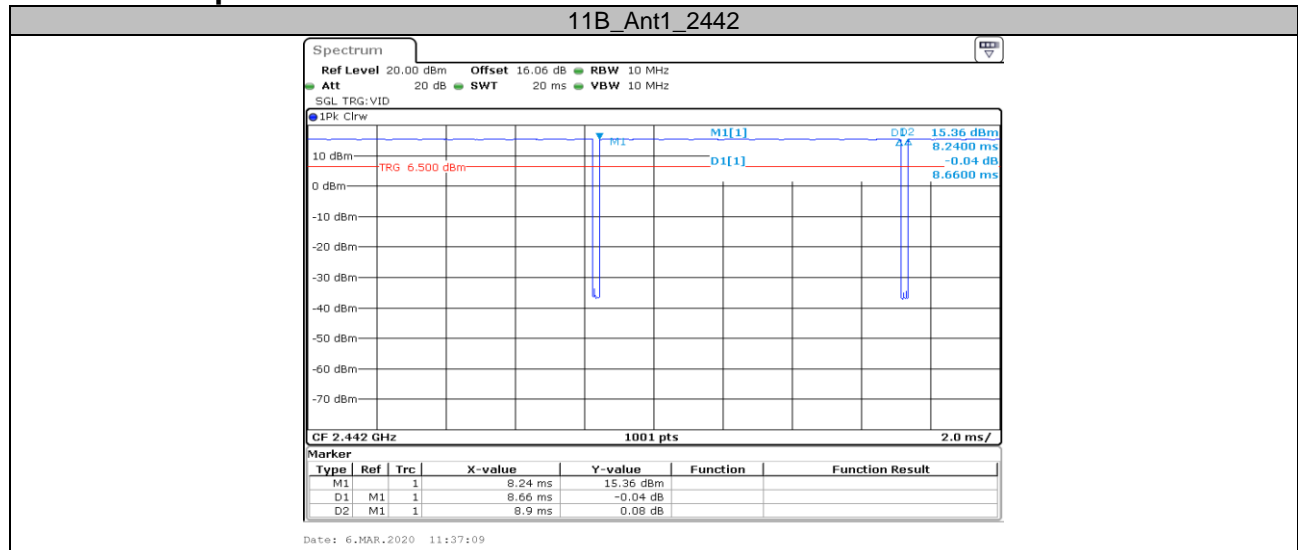

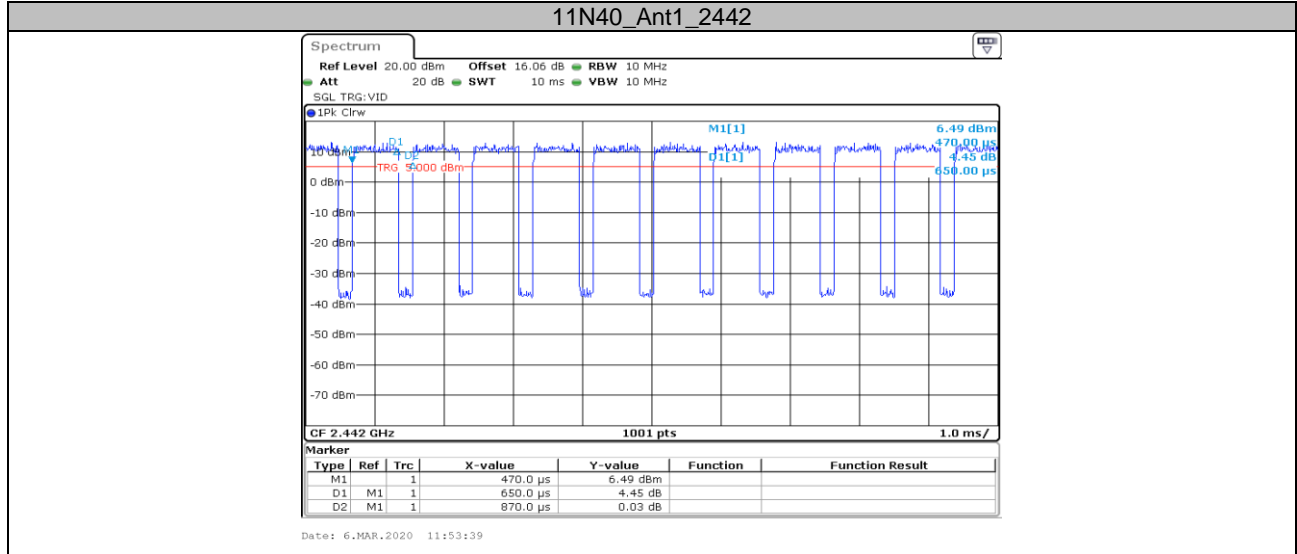

**\*\*\*\*\* END OF REPORT \*\*\*\*\***