

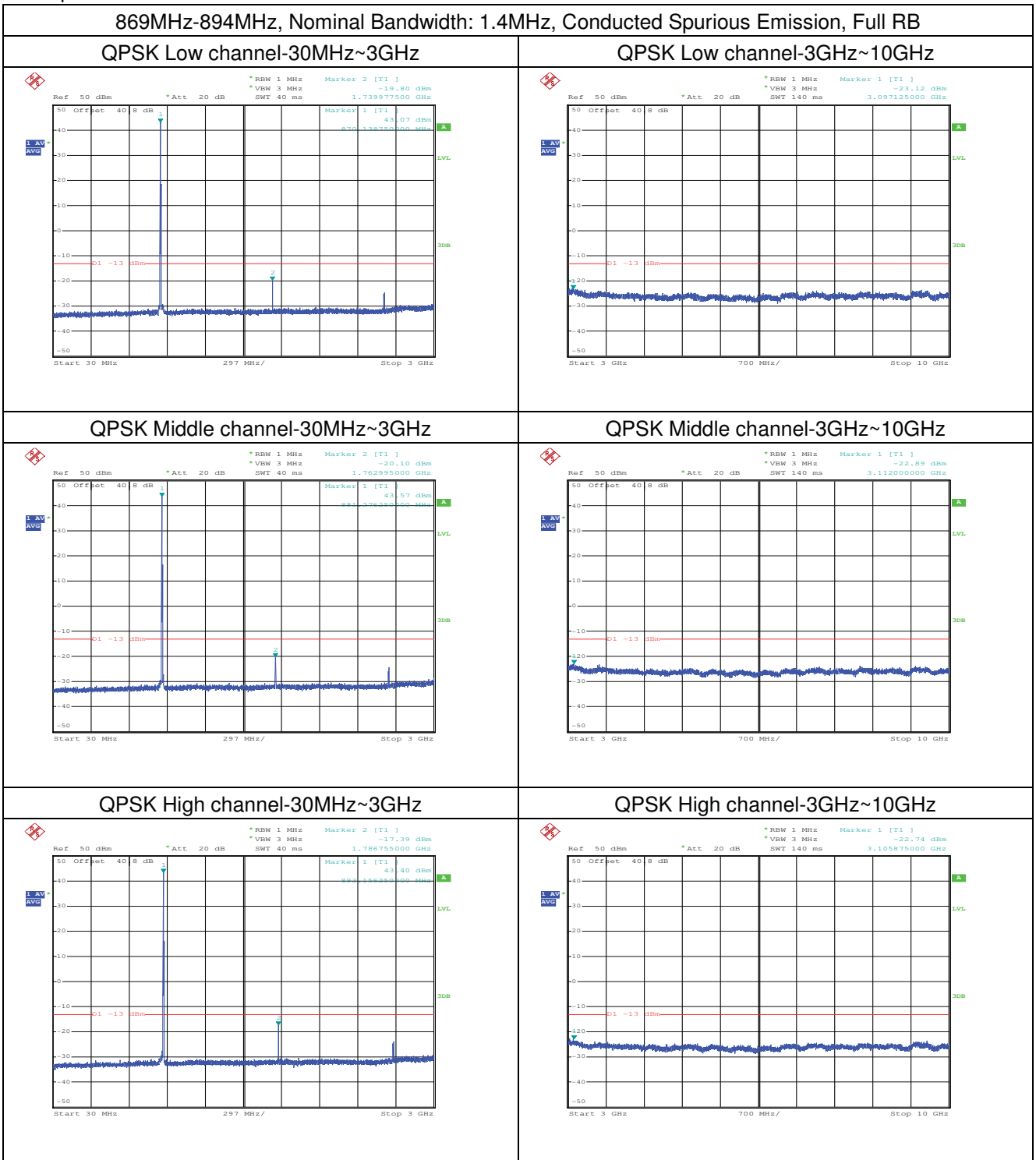

Test plot for 869MHz-894MHz:

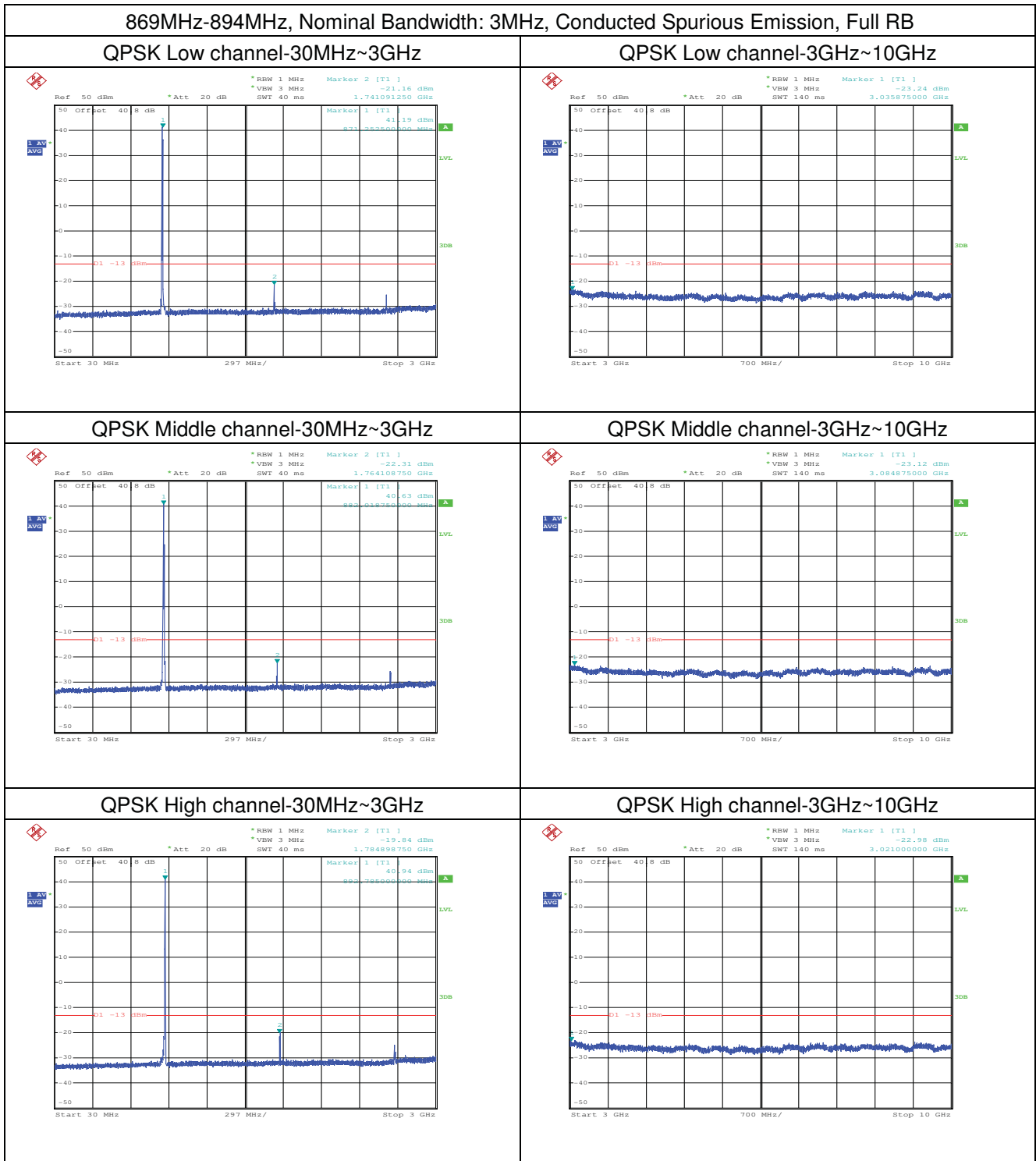

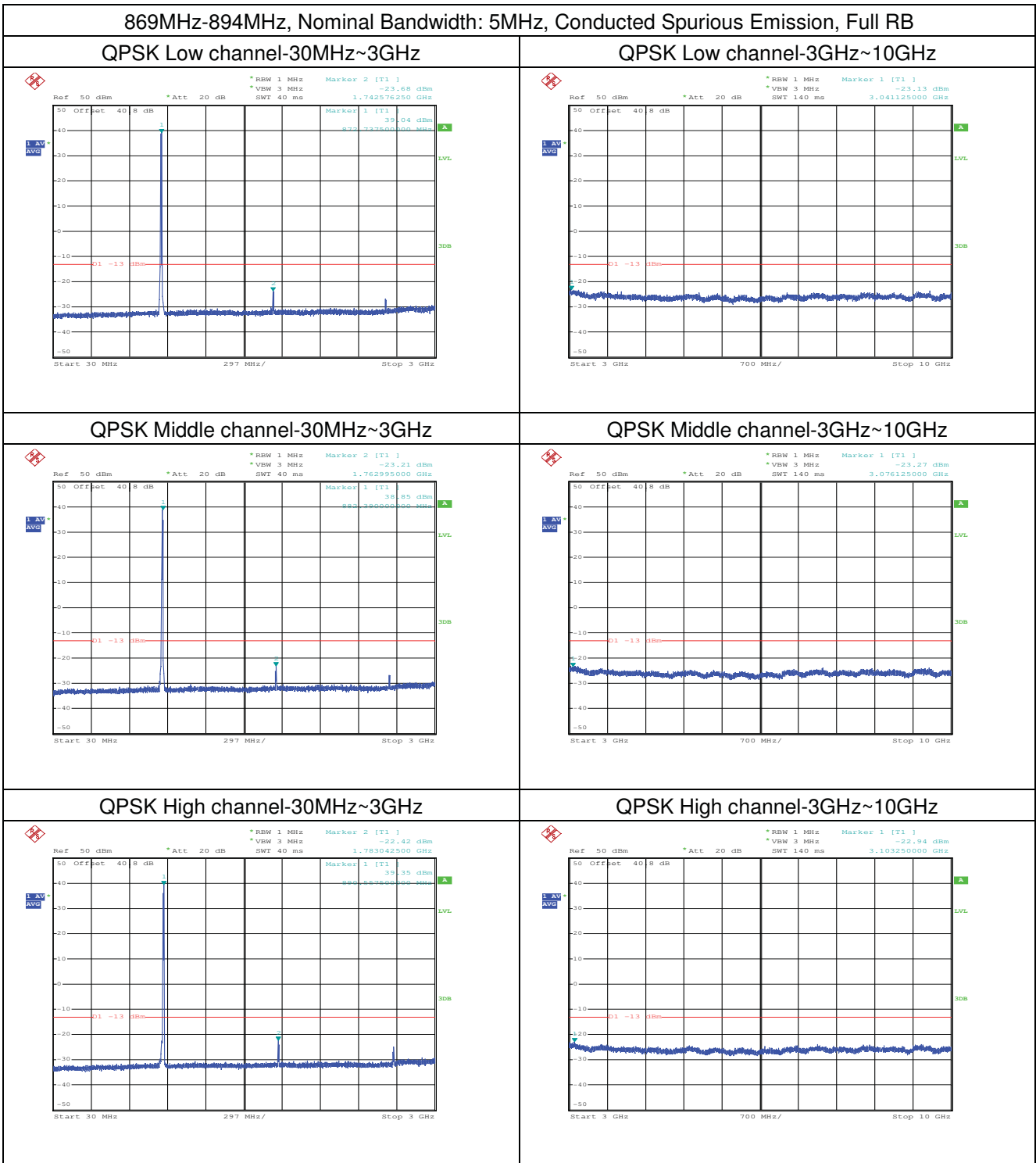



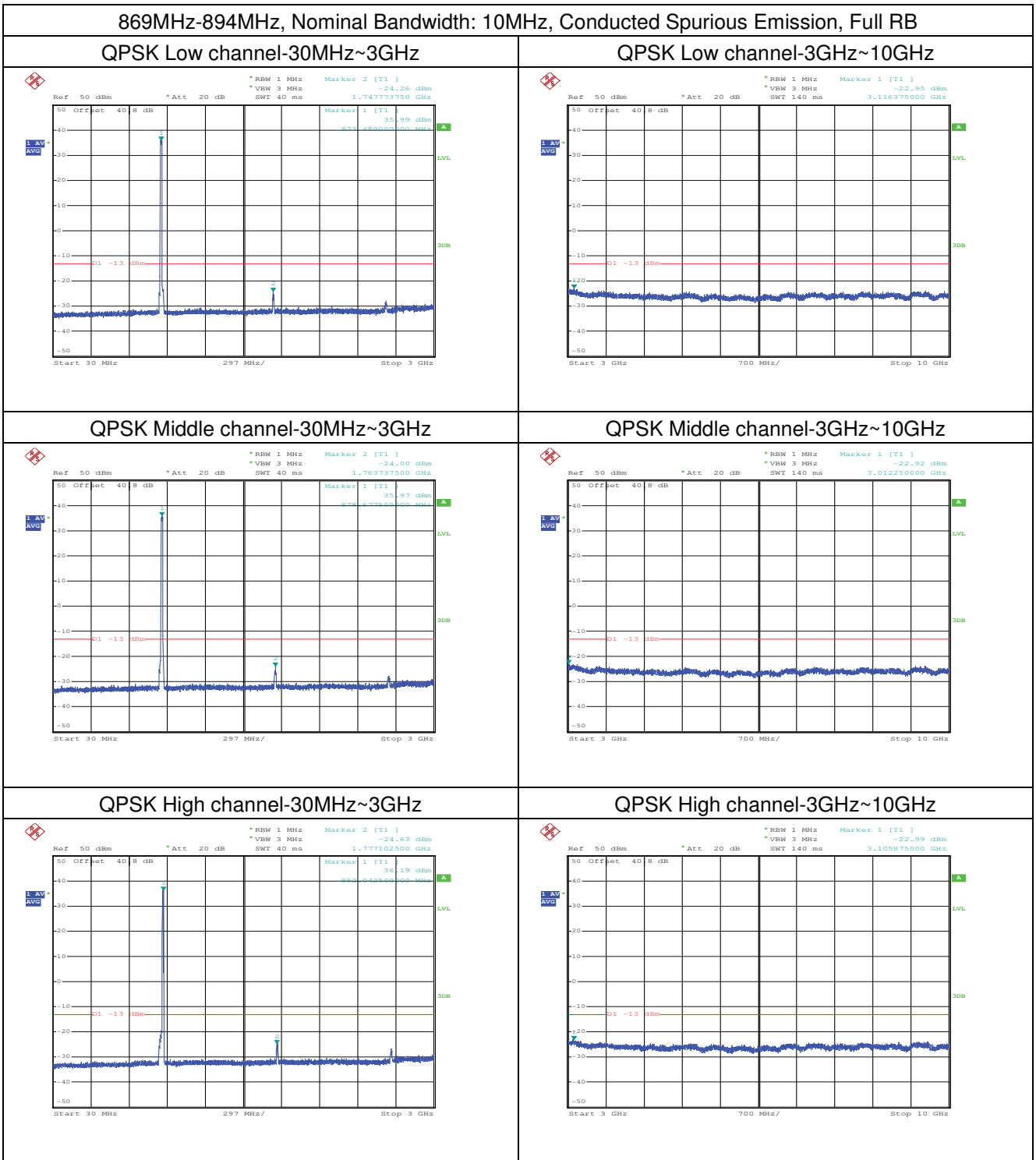

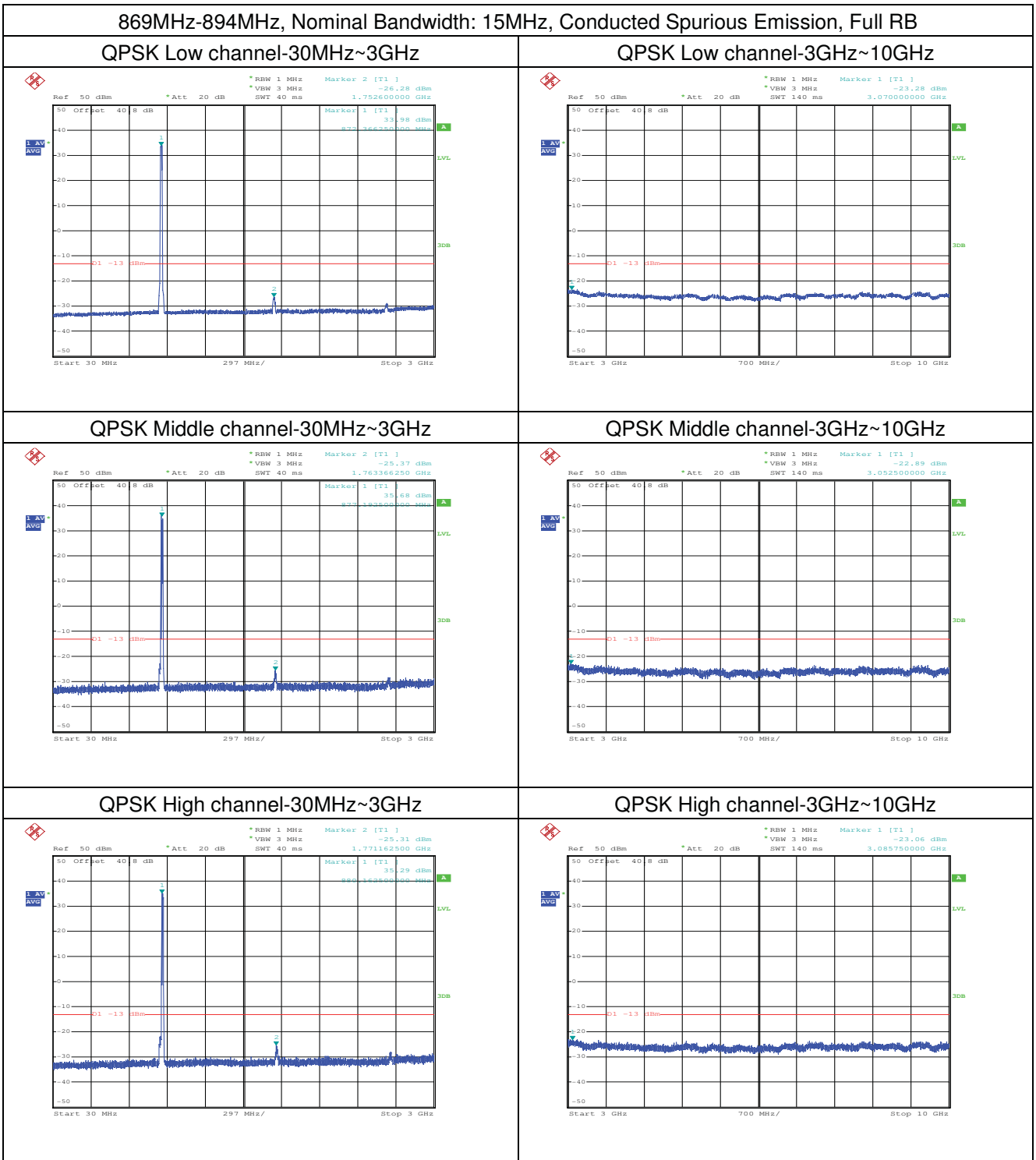

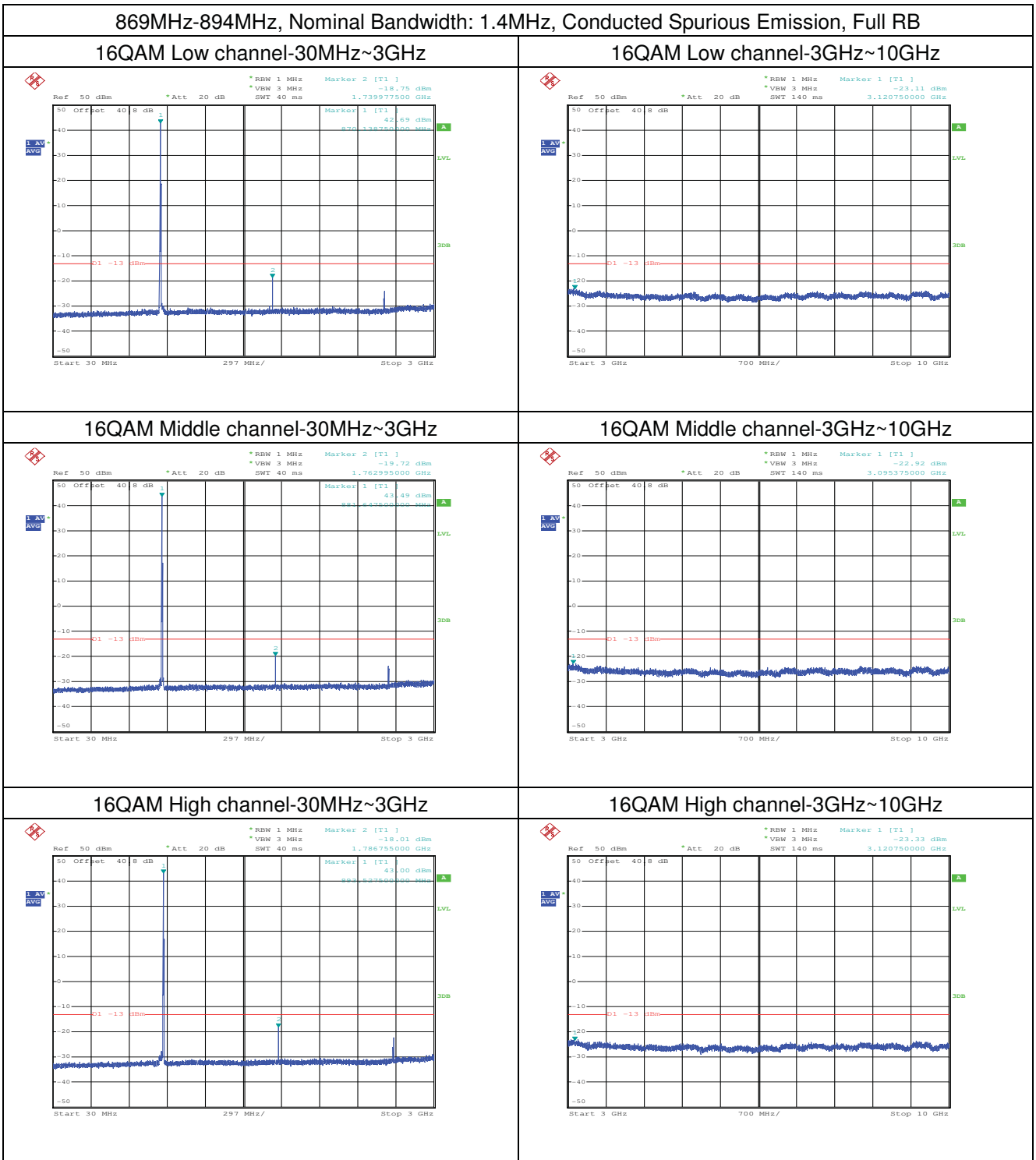

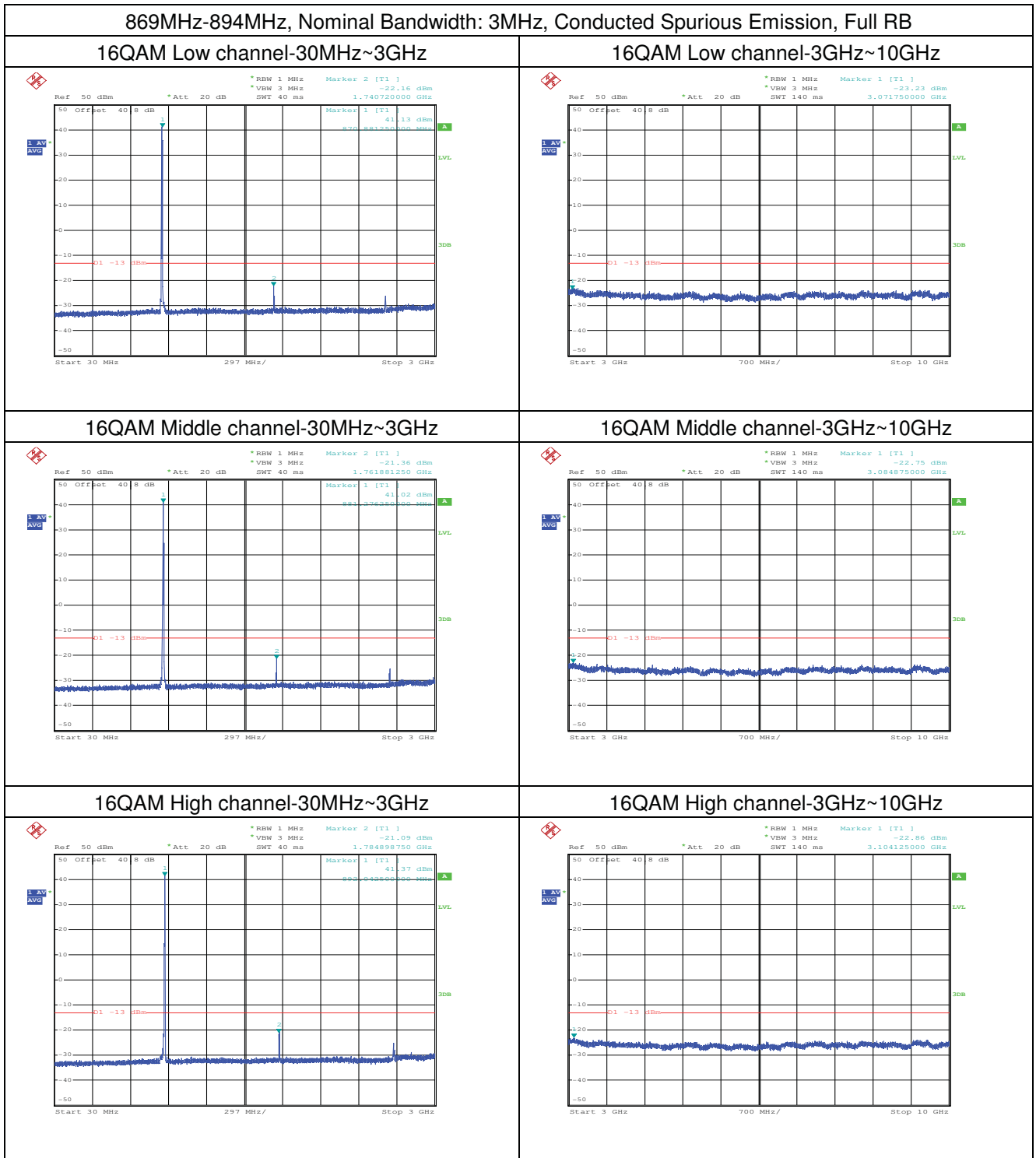

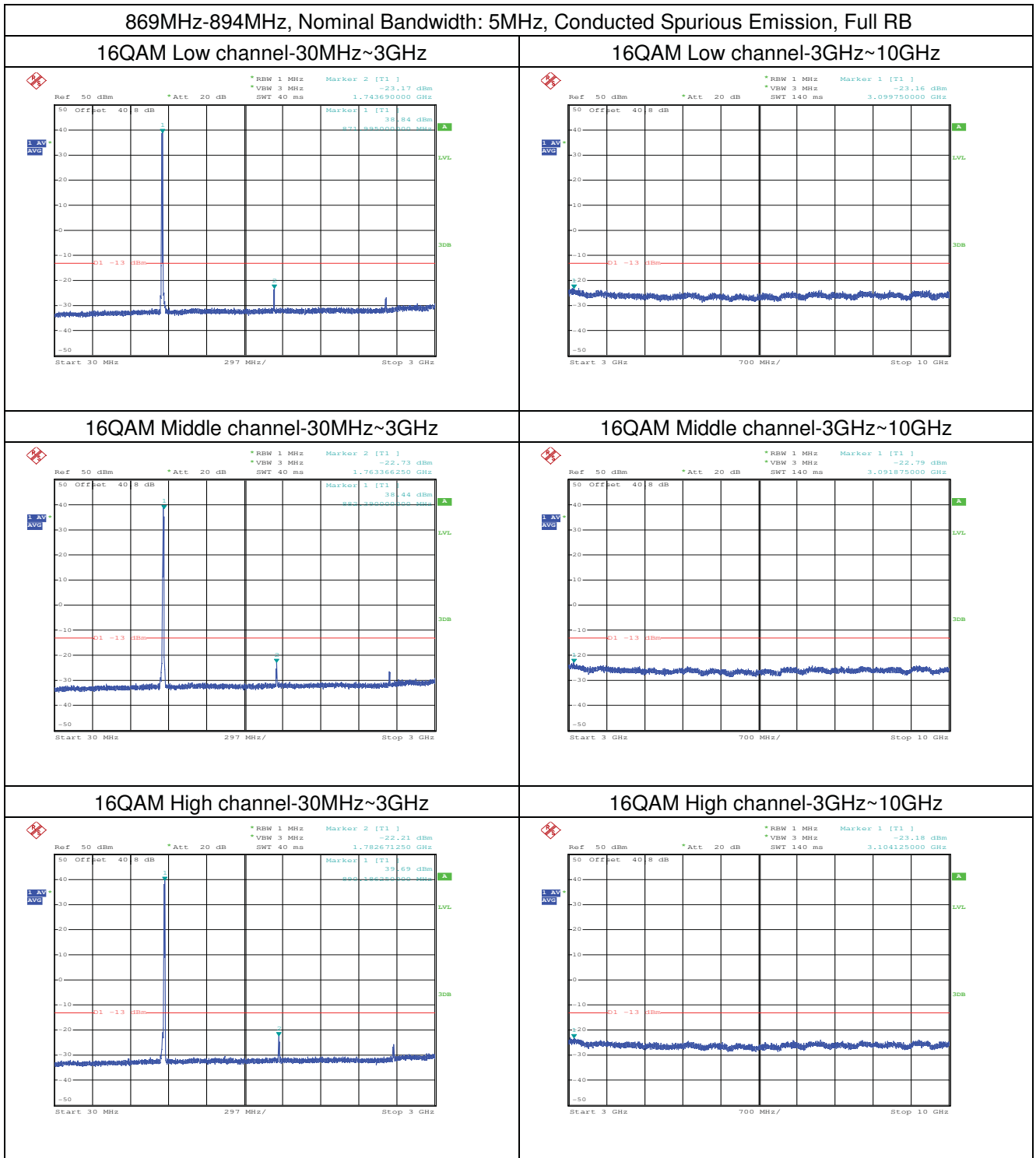

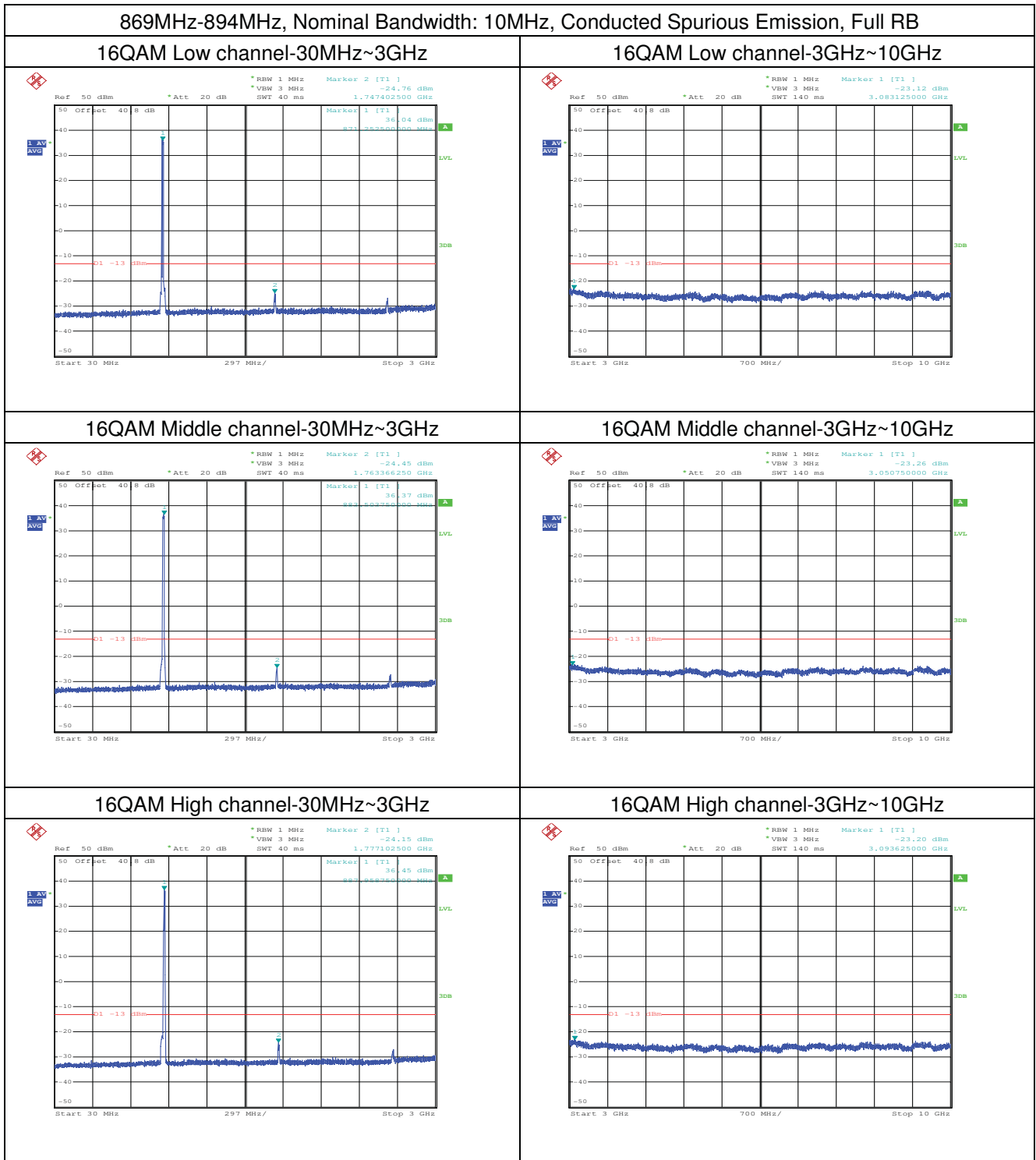

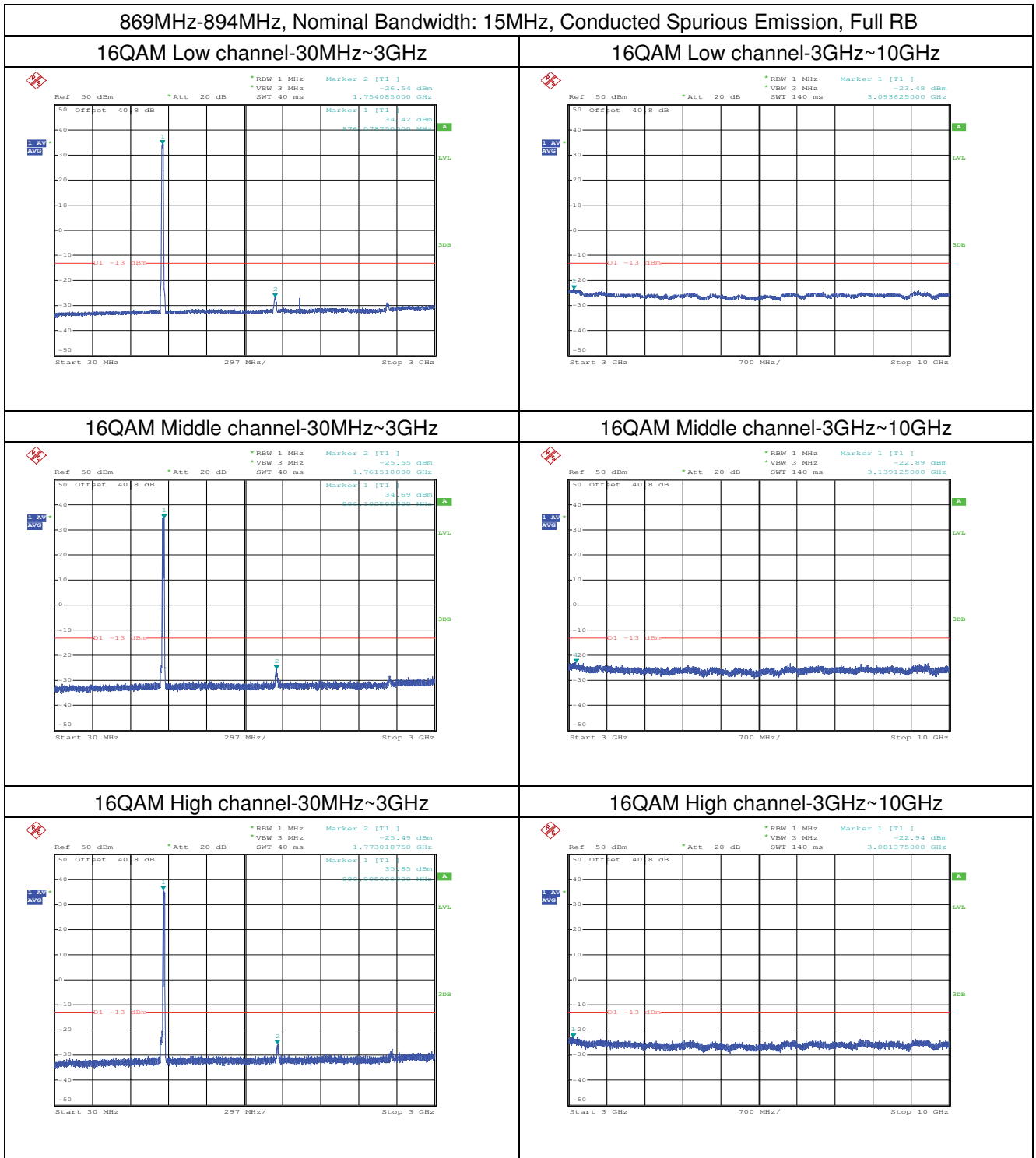

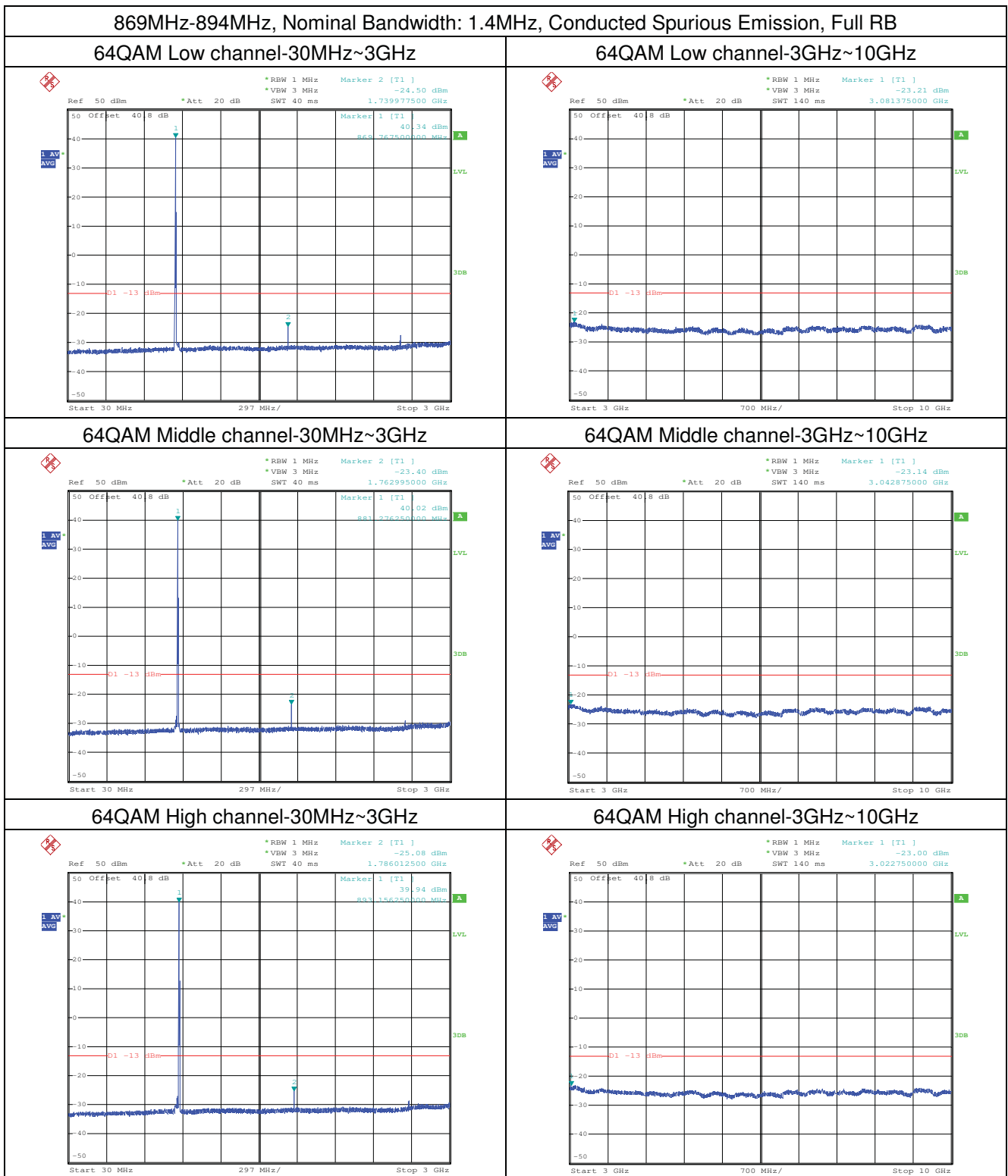

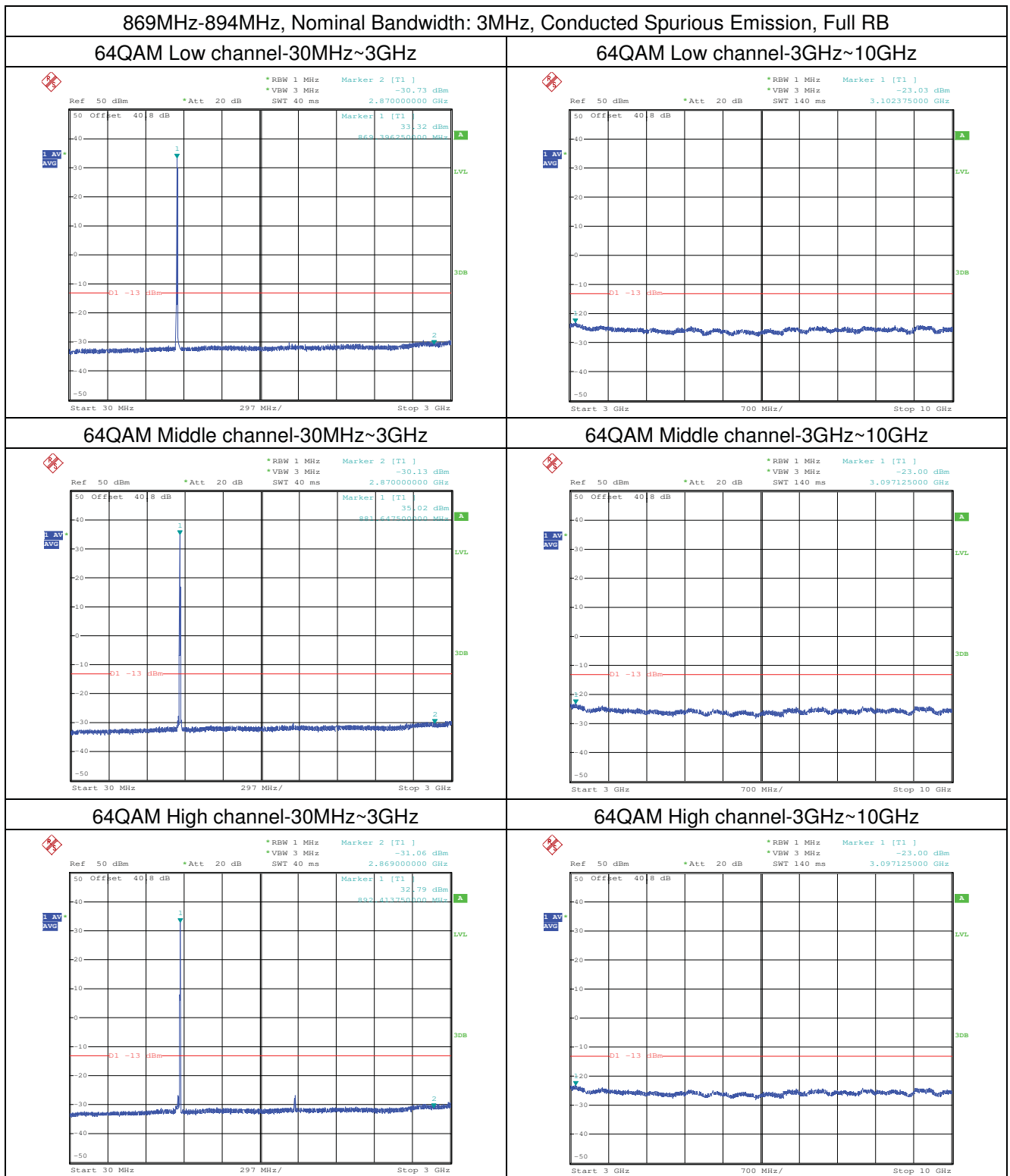

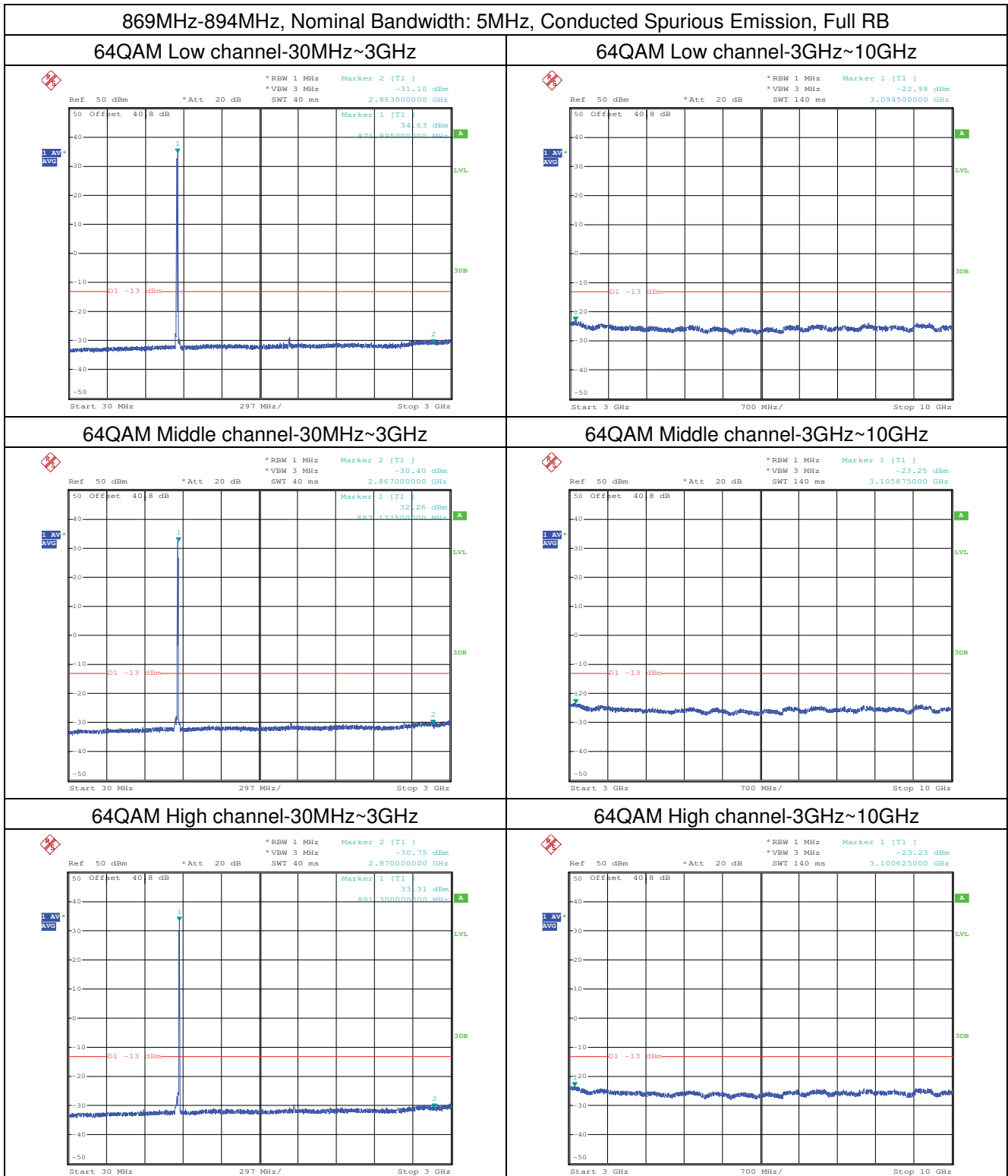

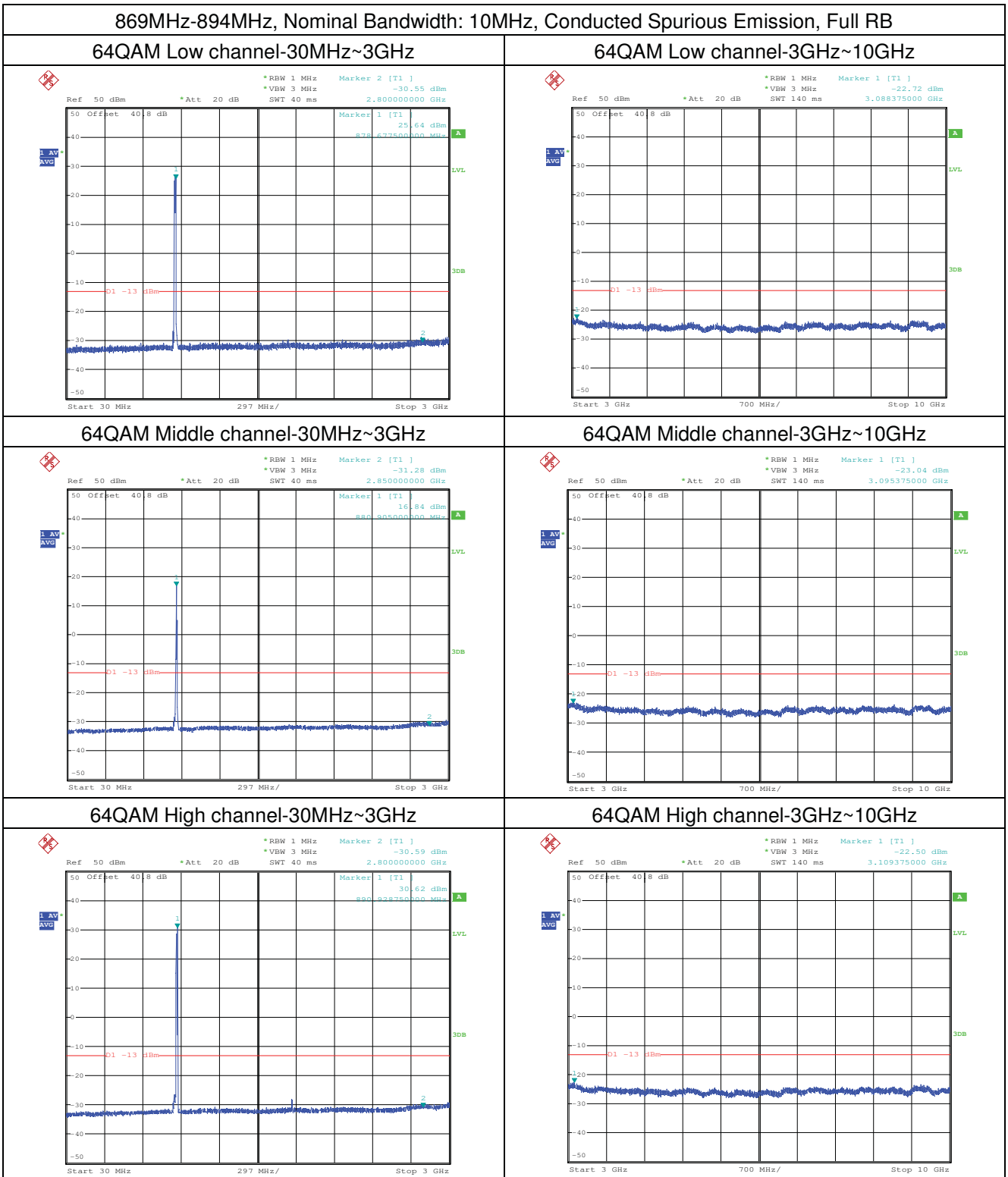

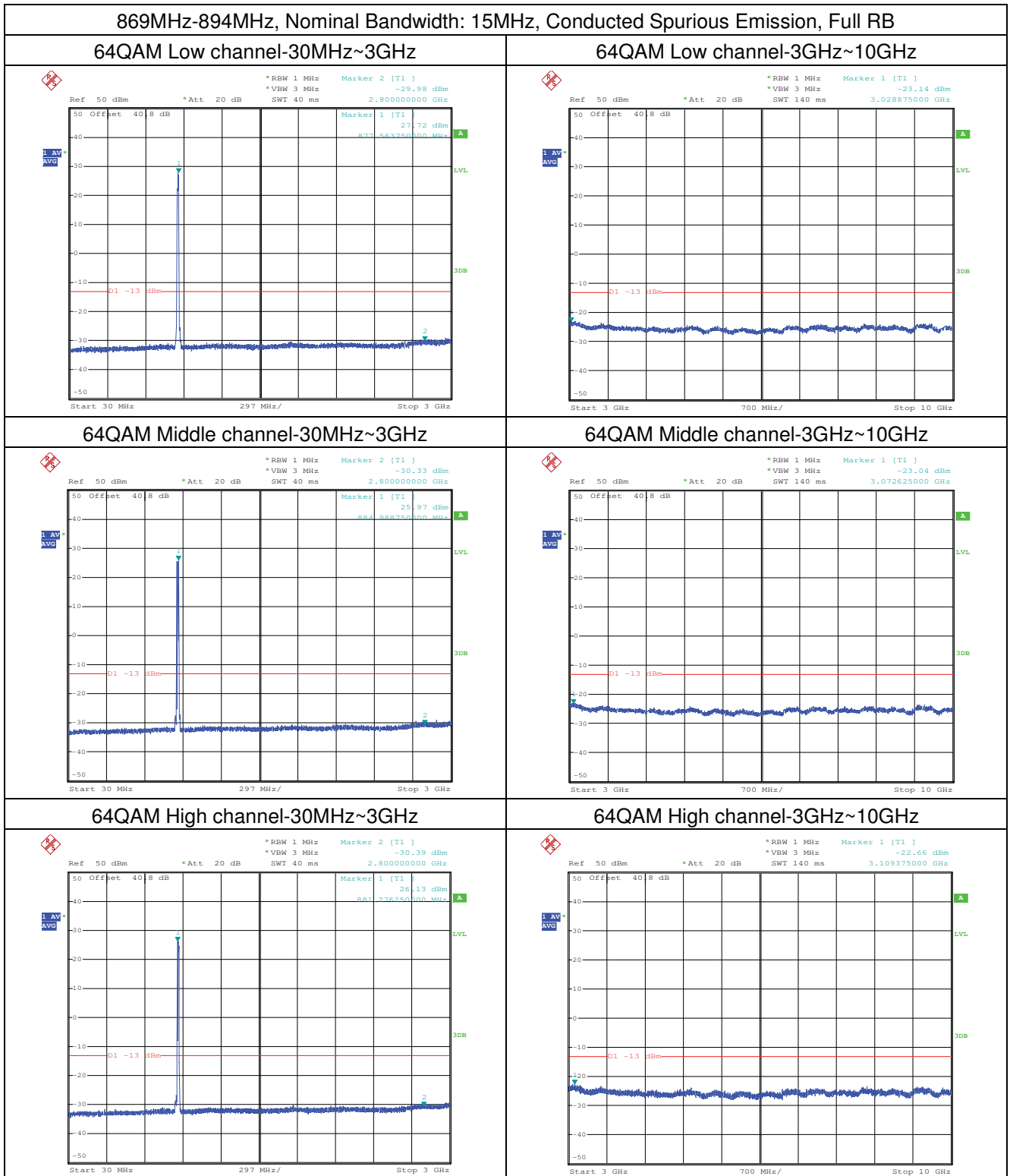

6.6 Field strength of spurious radiation

Test Requirement: §2.1051, §22.917, §90.691
 Test Method: ANSI C63.26, KDB 971168 D01 v03
 Limit: $\leq -13\text{dBm}$

6.6.1 E.U.T. Operation

Operating Environment:

Temperature: 25 °C Humidity: 54 % RH Atmospheric Pressure: 1015 mbar

Test mode: b: Tx mode, Keep the EUT in transmitting mode.

6.6.2 Test Setup Diagram

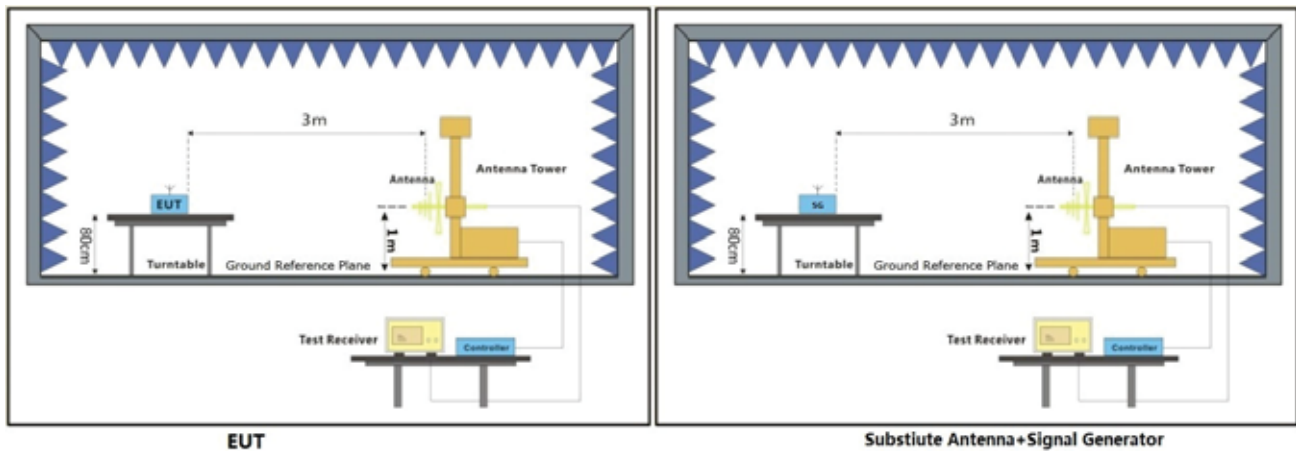



6.6.3 Measurement Procedure and Data

Test Procedure:

- (1) On a test site, the EUT shall be placed on a turntable and in the position closest to the normal use as declared by the user.
- (2) The test antenna shall be oriented initially for vertical polarization located 3m from the EUT to correspond to the transmitter.
- (3) The output of the antenna shall be connected to the measuring receiver and either a peak or quasi-peak detector was used for the measurement as indicated on the report. The detector selection is based on how close the emission level was approaching the limit.
- (4) The transmitter shall be switched on; if possible, without the modulation and the measurement receiver shall be tuned to the frequency of the transmitter under test.
- (5) The test antenna shall be raised and lowered through the specified range of height until the measuring receiver detects a maximum signal level.
- (6) The transmitter shall then be rotated through 360° in the horizontal plane, until the maximum signal level is detected by the measuring receiver.
- (7) The test antenna shall be raised and lowered again through the specified range of height until the measuring receiver detects a maximum signal level.
- (8) The maximum signal level detected by the measuring receiver shall be noted.
- (9) The measurement shall be repeated with the test antenna set to horizontal polarization.
- (10) Replace the antenna with a proper Antenna (substitution antenna).
- (11) The substitution antenna shall be oriented for vertical polarization and, if necessary, the length of the substitution antenna shall be adjusted to correspond to the frequency of transmitting.
- (12) The substitution antenna shall be connected to a calibrated signal generator.
- (13) If necessary, the input attenuator setting of the measuring receiver shall be adjusted in order to increase the sensitivity of the measuring receiver.
- (14) The test antenna shall be raised and lowered through the specified range of the height to ensure that the maximum signal is received.
- (15) The input signal to substitution antenna shall be adjusted to the level that produces a level detected by the measuring receiver, that is equal to the level noted while the transmitter radiated power was measured, corrected for the change of input attenuation setting of the measuring receiver.
- (16) The input level to the substitution antenna shall be recorded as power level in dBm, corrected for any change of input attenuator setting of the measuring receiver.
- (17) The measurement shall be repeated with the test antenna and the substitution antenna oriented for horizontal polarization.



Test data for 859MHz-869MHz:

Low channel, Modulation: QPSK, Bandwidth: 1.4MHz, Full RB								
Frequency (MHz)	S.G. Power (dBm)	Cable loss (dB)	Antenna Gain (dBi)	EIRP (dBm)	Limit (dBm)	Over Limit (dB)	Polarization (H/V)	Result
1719.4	-62.82	0.52	6	-59.49	-13	-46.49	Horizontal	Pass
2579.1	-54.49	0.59	5.3	-51.93	-13	-38.93	Horizontal	Pass
3438.8	-55.01	0.65	6.2	-51.61	-13	-38.61	Horizontal	Pass
1719.4	-54.15	0.52	6	-50.82	-13	-37.82	Vertical	Pass
2579.1	-56.09	0.59	5.3	-53.53	-13	-40.53	Vertical	Pass
3438.8	-51	0.65	6.2	-47.6	-13	-34.6	Vertical	Pass

Middle channel, Modulation: QPSK, Bandwidth: 1.4MHz, Full RB								
Frequency (MHz)	S.G. Power (dBm)	Cable loss (dB)	Antenna Gain (dBi)	EIRP (dBm)	Limit (dBm)	Over Limit (dB)	Polarization (H/V)	Result
1728	-61.95	0.52	6	-58.62	-13	-45.62	Horizontal	Pass
2592	-57.24	0.59	5.3	-54.68	-13	-41.68	Horizontal	Pass
3456	-54.77	0.65	6.2	-51.37	-13	-38.37	Horizontal	Pass
1728	-54.23	0.52	6	-50.9	-13	-37.9	Vertical	Pass
2592	-56.36	0.59	5.3	-53.8	-13	-40.8	Vertical	Pass
3456	-55.61	0.65	6.2	-52.21	-13	-39.21	Vertical	Pass

High channel, Modulation: QPSK, Bandwidth: 1.4MHz, Full RB								
Frequency (MHz)	S.G. Power (dBm)	Cable loss (dB)	Antenna Gain (dBi)	EIRP (dBm)	Limit (dBm)	Over Limit (dB)	Polarization (H/V)	Result
1736.6	-59.39	0.52	6	-56.06	-13	-43.06	Horizontal	Pass
2604.9	-59.93	0.59	5.3	-57.37	-13	-44.37	Horizontal	Pass
3473.2	-56.37	0.65	6.2	-52.97	-13	-39.97	Horizontal	Pass
1736.6	-55.03	0.52	6	-51.7	-13	-38.7	Vertical	Pass
2604.9	-57.15	0.59	5.3	-54.59	-13	-41.59	Vertical	Pass
3473.2	-56.46	0.65	6.2	-53.06	-13	-40.06	Vertical	Pass

Note: All modes have been tested and we found max bandwidth, full RB Test mode has the worst test result. Only record the worst test result.



Test data for 869MHz-894MHz:

Low channel, Modulation: QPSK, Bandwidth: 1.4MHz, Full RB								
Frequency (MHz)	S.G. Power (dBm)	Cable loss (dB)	Antenna Gain (dBi)	EIRP (dBm)	Limit (dBm)	Over Limit (dB)	Polarization (H/V)	Result
1739.4	-60.43	0.52	6	-57.1	-13	-44.1	Horizontal	Pass
2609.1	-56.17	0.59	5.3	-53.61	-13	-40.61	Horizontal	Pass
3478.8	-54.83	0.65	6.2	-51.43	-13	-38.43	Horizontal	Pass
1739.4	-53.98	0.52	6	-50.65	-13	-37.65	Vertical	Pass
2609.1	-53.01	0.59	5.3	-50.45	-13	-37.45	Vertical	Pass
3478.8	-54.31	0.65	6.2	-50.91	-13	-37.91	Vertical	Pass

Middle channel, Modulation: QPSK, Bandwidth: 1.4MHz, Full RB								
Frequency (MHz)	S.G. Power (dBm)	Cable loss (dB)	Antenna Gain (dBi)	EIRP (dBm)	Limit (dBm)	Over Limit (dB)	Polarization (H/V)	Result
1763	-61.35	0.52	6	-58.02	-13	-45.02	Horizontal	Pass
2644.5	-57.5	0.59	5.3	-54.94	-13	-41.94	Horizontal	Pass
3526	-56.63	0.71	7.6	-51.89	-13	-38.89	Horizontal	Pass
1763	-54.14	0.52	6	-50.81	-13	-37.81	Vertical	Pass
2644.5	-55	0.59	5.3	-52.44	-13	-39.44	Vertical	Pass
3526	-56.78	0.71	7.6	-52.04	-13	-39.04	Vertical	Pass

High channel, Modulation: QPSK, Bandwidth: 1.4MHz, Full RB								
Frequency (MHz)	S.G. Power (dBm)	Cable loss (dB)	Antenna Gain (dBi)	EIRP (dBm)	Limit (dBm)	Over Limit (dB)	Polarization (H/V)	Result
1786.6	-62.12	0.52	6	-58.79	-13	-45.79	Horizontal	Pass
2679.9	-56.94	0.59	5.3	-54.38	-13	-41.38	Horizontal	Pass
3573.2	-56.71	0.71	7.6	-51.97	-13	-38.97	Horizontal	Pass
1786.6	-53.46	0.52	6	-50.13	-13	-37.13	Vertical	Pass
2679.9	-52.31	0.59	5.3	-49.75	-13	-36.75	Vertical	Pass
3573.2	-56.61	0.71	7.6	-51.87	-13	-38.87	Vertical	Pass

Note: All modes have been tested and we found min bandwidth, full RB Test mode has the worst test result. Only record the worst test result.

6.7 Frequency stability

Test Requirement: §2.1055, §22.355, §90.213
Test Method: ANSI C63.26, KDB 971168 D01 v03
Limit: $\leq \pm 1.5\text{ppm}$.

6.7.1 E.U.T. Operation

Operating Environment:

Temperature: 25 °C Humidity: 54 % RH Atmospheric Pressure: 1015 mbar

Test mode: b: Tx mode, Keep the EUT in transmitting mode.

6.7.2 Test Setup Diagram

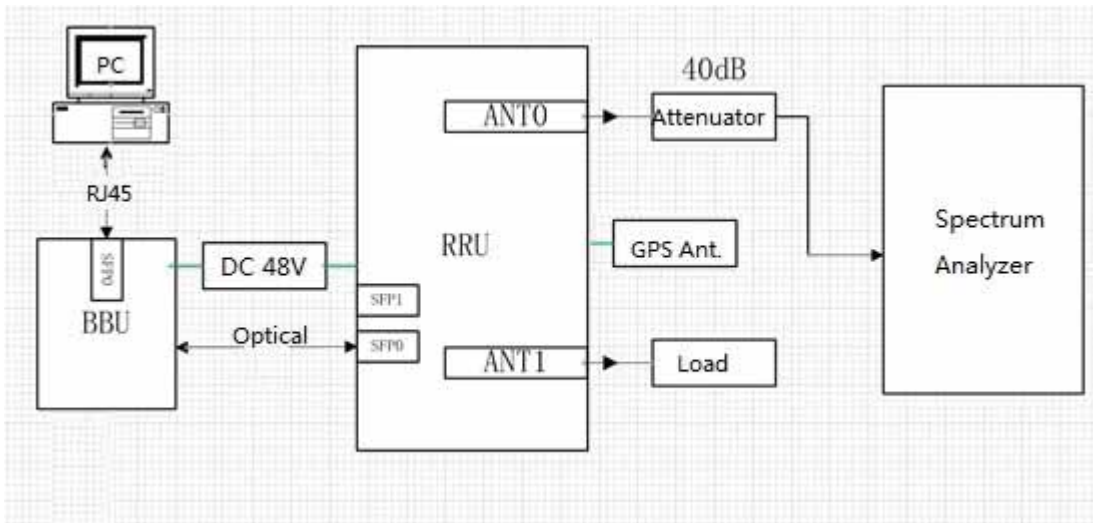

6.7.3 Measurement Data

Note: All modes have been tested and we found min bandwidth, full RB Test mode: has the worst test result. Only record the worst test result.



Frequency Error VS. Voltage

Test Band	Test mode:	Test Channel	Test Temp.	Test Volt.	Freq. Error [Hz]	Freq. vs. rated [ppm]	Verdict
859-869MHz	QPSK/1.4MHz	LCH	TN	VL	4.51	0.00525	PASS
				VN	0.45	0.00052	PASS
				VH	2.76	0.00321	PASS
		MCH	TN	VL	1.41	0.00163	PASS
				VN	2.88	0.00333	PASS
				VH	2.66	0.00308	PASS
		HCH	TN	VL	1.52	0.00175	PASS
				VN	1.13	0.00130	PASS
				VH	-0.71	-0.00082	PASS
	16QAM/1.4MHz	LCH	TN	VL	4.2	0.00489	PASS
				VN	2.93	0.00341	PASS
				VH	3.18	0.00370	PASS
		MCH	TN	VL	1.59	0.00184	PASS
				VN	2.88	0.00333	PASS
				VH	2.52	0.00292	PASS
		HCH	TN	VL	3.02	0.00348	PASS
				VN	2.09	0.00241	PASS
				VH	1.48	0.00170	PASS

Test Band	Test mode:	Test Channel	Test Temp.	Test Volt.	Freq. Error [Hz]	Freq. vs. rated [ppm]	Verdict
869-894MHz	QPSK/1.4MHz	LCH	TN	VL	4.52	0.00520	PASS
				VN	0.42	0.00048	PASS
				VH	1.74	0.00200	PASS
		MCH	TN	VL	1.43	0.00162	PASS
				VN	2.81	0.00319	PASS
				VH	2.6	0.00295	PASS
		HCH	TN	VL	2.52	0.00282	PASS
				VN	1.12	0.00125	PASS
				VH	-0.71	-0.00079	PASS
	16QAM/1.4MHz	LCH	TN	VL	4.22	0.00485	PASS
				VN	2.91	0.00335	PASS
				VH	1.11	0.00128	PASS
		MCH	TN	VL	1.57	0.00178	PASS
				VN	2.85	0.00323	PASS
				VH	2.51	0.00285	PASS
		HCH	TN	VL	3.02	0.00338	PASS
				VN	2.01	0.00225	PASS
				VH	0.4	0.00045	PASS



Frequency Error VS. Temperature

Test Band	Test mode:	Test Channel	Test Volt.	Test Temp.	Freq. Error [Hz]	Freq. vs. rated [ppm]	Verdict
859-869MHz	QPSK/1.4MHz	LCH	VN	-20	0.83	0.00097	PASS
				-10	-0.01	-0.00001	PASS
				0	2.62	0.00305	PASS
				10	3.02	0.00351	PASS
				20	2.94	0.00342	PASS
				30	1.42	0.00165	PASS
				40	3.91	0.00455	PASS
				50	1.14	0.00133	PASS
				55	1.82	0.00212	PASS
		MCH	VN	-30	3.52	0.00407	PASS
				-20	4.62	0.00535	PASS
				-10	-1.12	-0.00130	PASS
				0	4.36	0.00505	PASS
				10	2.74	0.00317	PASS
				20	2.66	0.00308	PASS
				30	2.31	0.00267	PASS
				40	3.31	0.00383	PASS
				50	1.62	0.00188	PASS
		HCH	VN	-20	1.81	0.00208	PASS
				-10	-0.15	-0.00017	PASS
				0	2.83	0.00326	PASS
				10	1.58	0.00182	PASS
				20	3.94	0.00454	PASS
				30	0.76	0.00088	PASS
40	1.37			0.00158	PASS		
50	2.11			0.00243	PASS		
55	3.62	0.00417	PASS				



**SGS-CSTC Standards Technical Services Co., Ltd.
Shenzhen Branch**

Report No.: SZEM181000903102

Page: 120 of 123

Test Band	Test mode:	Test Channel	Test Volt.	Test Temp.	Freq. Error [Hz]	Freq. vs. rated [ppm]	Verdict
859-869MHz	16QAM/1.4MHz	LCH	VN	-20	0.3	0.00035	PASS
				-10	1.69	0.00197	PASS
				0	4.08	0.00475	PASS
				10	3.64	0.00423	PASS
				20	2.7	0.00314	PASS
				30	0.87	0.00101	PASS
				40	0.66	0.00077	PASS
				50	2.84	0.00330	PASS
				55	1.69	0.00197	PASS
		MCH	VN	-30	2.64	0.00306	PASS
				-20	4.42	0.00512	PASS
				-10	2.83	0.00328	PASS
				0	3.96	0.00458	PASS
				10	0.06	0.00007	PASS
				20	2.84	0.00329	PASS
				30	2.58	0.00299	PASS
				40	1.86	0.00215	PASS
				50	2.45	0.00284	PASS
		HCH	VN	-20	2.64	0.00304	PASS
				-10	1.49	0.00172	PASS
				0	2.69	0.00310	PASS
				10	2.47	0.00284	PASS
				20	3.78	0.00435	PASS
				30	-0.37	-0.00043	PASS
				40	2.23	0.00257	PASS
				50	3.47	0.00400	PASS
				55	2.94	0.00339	PASS



**SGS-CSTC Standards Technical Services Co., Ltd.
Shenzhen Branch**

Report No.: SZEM181000903102

Page: 121 of 123

Test Band	Test mode:	Test Channel	Test Volt.	Test Temp.	Freq. Error [Hz]	Freq. vs. rated [ppm]	Verdict
869-894MHz	QPSK/15MHz	LCH	VN	-30	0.6	0.00069	PASS
				-20	-0.27	-0.00031	PASS
				-10	3.42	0.00393	PASS
				0	2.81	0.00323	PASS
				10	2.68	0.00308	PASS
				20	1.22	0.00140	PASS
				30	0.73	0.00084	PASS
				40	0.88	0.00101	PASS
				50	1.6	0.00184	PASS
		MCH	VN	-30	2.84	0.00322	PASS
				-20	4.98	0.00565	PASS
				-10	2.44	0.00277	PASS
				0	4.68	0.00531	PASS
				10	3.1	0.00352	PASS
				20	3.98	0.00452	PASS
				30	4.63	0.00525	PASS
				40	3.68	0.00417	PASS
				50	1.94	0.00220	PASS
		HCH	VN	-30	1.63	0.00182	PASS
				-20	0.5	0.00056	PASS
				-10	2.57	0.00288	PASS
				0	1.9	0.00213	PASS
				10	3.68	0.00412	PASS
				20	0.5	0.00056	PASS
				30	-1.63	-0.00182	PASS
				40	4.43	0.00496	PASS
				50	2.99	0.00335	PASS



Test Band	Test mode:	Test Channel	Test Volt.	Test Temp.	Freq. Error [Hz]	Freq. vs. rated [ppm]	Verdict
869-894MHz	16QAM/15MHz	LCH	VN	-30	1.03	0.00118	PASS
				-20	-0.82	-0.00094	PASS
				-10	4.81	0.00553	PASS
				0	4.37	0.00502	PASS
				10	3.43	0.00394	PASS
				20	1.6	0.00184	PASS
				30	1.39	0.00160	PASS
				40	3.57	0.00410	PASS
				50	2.42	0.00278	PASS
		MCH	VN	-30	-1.77	-0.00201	PASS
				-20	-3.55	-0.00403	PASS
				-10	-0.96	-0.00109	PASS
				0	-3.09	-0.00351	PASS
				10	0.79	0.00090	PASS
				20	3.57	0.00405	PASS
				30	-1.71	-0.00194	PASS
				40	-0.99	-0.00112	PASS
				50	-1.58	-0.00179	PASS
		HCH	VN	-30	3.37	0.00377	PASS
				-20	-0.62	-0.00069	PASS
				-10	3.42	0.00383	PASS
				0	-1.6	-0.00179	PASS
				10	4.51	0.00505	PASS
				20	0.36	0.00040	PASS
				30	-1.36	-0.00152	PASS
				40	-2.6	-0.00291	PASS
				50	-1.07	-0.00120	PASS

Note: All modes have been tested and we only record the worst test result.

6.8 Modulation Characteristics

Test Requirement: §2.1047
Test Method: ANSI C63.26, KDB 971168 D01 v03
Limit: Digital modulation

6.8.1 E.U.T. Operation

Operating Environment:

Temperature: 25 °C Humidity: 54 % RH Atmospheric Pressure: 1015 mbar

Test mode: b: Tx mode, Keep the EUT in transmitting mode.

6.8.2 Test Setup Diagram

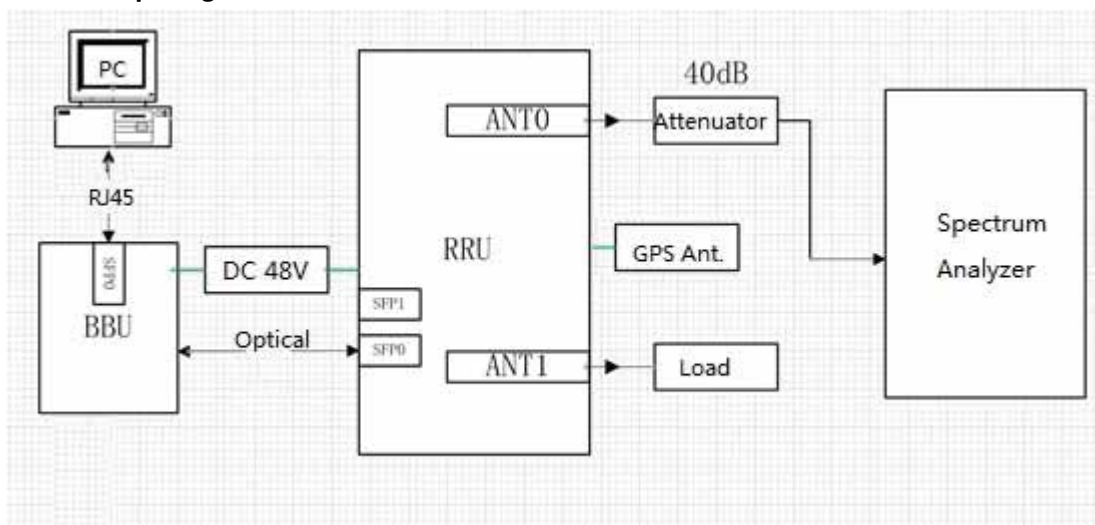

6.8.3 Measurement Data

Please see clause 6.3 of this report, the modulation characteristic of the base station transceiver is 14M7G7D and 14M6W7D.

No further testing is required under this section of the FCC rules. No measurements other than the occupied bandwidth are required.

The modulation characteristics were found to be compliant with the manufacturer's specifications and with all requirements of the FCC rules.

- End of the Report -