

FCC Test Report

Report No.: RF160427E04

FCC ID: YAI2213

Test Model: 2213

Received Date: Apr. 29, 2016

Test Date: June 21 to 22, 2016

Issued Date: July 28, 2016

Applicant: InnoComm Mobile Technology Corp.

Address: 3F, No. 6, Hsin Ann Rd., Hsinchu Science Park, Hsinchu 30078, Taiwan

Issued By: Bureau Veritas Consumer Products Services (H.K.) Ltd., Taoyuan Branch
Hsin Chu Laboratory

Lab Address: E-2, No.1, Li Hsin 1st Road, Hsinchu Science Park, Hsinchu City 300,
Taiwan R.O.C.

Test Location (1): E-2, No.1, Li Hsin 1st Road, Hsinchu Science Park, Hsinchu City 300,
Taiwan R.O.C.

Test Location (2): No. 49, Ln. 206, Wende Rd., Shangshan Tsuen, Chiung Lin Hsiang, Hsin
Chu Hsien 307, Taiwan R.O.C.



This report is for your exclusive use. Any copying or replication of this report to or for any other person or entity, or use of our name or trademark, is permitted only with our prior written permission. This report sets forth our findings solely with respect to the test samples identified herein. The results set forth in this report are not indicative or representative of the quality or characteristics of the lot from which a test sample was taken or any similar or identical product unless specifically and expressly noted. Our report includes all of the tests requested by you and the results thereof based upon the information that you provided to us. You have 60 days from date of issuance of this report to notify us of any material error or omission caused by our negligence, provided, however, that such notice shall be in writing and shall specifically address the issue you wish to raise. A failure to raise such issue within the prescribed time shall constitute your unqualified acceptance of the completeness of this report, the tests conducted and the correctness of the report contents. Unless specific mention, the uncertainty of measurement has been explicitly taken into account to declare the compliance or non-compliance to the specification. The report must not be used by the client to claim product certification, approval, or endorsement by TAF or any government agencies.

Table of Contents

Release Control Record	4
1 Certificate of Conformity	5
2 Summary of Test Results	6
2.1 Measurement Uncertainty	6
2.2 Modification Record	6
3 General Information	7
3.1 General Description of EUT	7
3.2 Description of Test Modes	8
3.2.1 Test Mode Applicability and Tested Channel Detail	9
3.3 Duty Cycle of Test Signal	11
3.4 Description of Support Units	12
3.4.1 Configuration of System under Test	13
3.5 General Description of Applied Standards	14
4 Test Types and Results	15
4.1 Radiated Emission and Bandedge Measurement	15
4.1.1 Limits of Radiated Emission and Bandedge Measurement	15
4.1.2 Test Instruments	16
4.1.3 Test Procedures	17
4.1.4 Deviation from Test Standard	17
4.1.5 Test Setup	18
4.1.6 EUT Operating Conditions	19
4.1.7 Test Results	20
4.2 Conducted Emission Measurement	30
4.2.1 Limits of Conducted Emission Measurement	30
4.2.2 Test Instruments	30
4.2.3 Test Procedures	31
4.2.4 Deviation from Test Standard	31
4.2.5 Test Setup	31
4.2.6 EUT Operating Conditions	31
4.2.7 Test Results	32
4.3 6dB Bandwidth Measurement	34
4.3.1 Limits of 6dB Bandwidth Measurement	34
4.3.2 Test Setup	34
4.3.3 Test Instruments	34
4.3.4 Test Procedure	34
4.3.5 Deviation from Test Standard	34
4.3.6 EUT Operating Conditions	34
4.3.7 Test Result	35
4.4 Conducted Output Power Measurement	37
4.4.1 Limits of Conducted Output Power Measurement	37
4.4.2 Test Setup	37
4.4.3 Test Instruments	37
4.4.4 Test Procedures	37
4.4.5 Deviation from Test Standard	37
4.4.6 EUT Operating Conditions	37
4.4.7 Test Results	38
4.5 Power Spectral Density Measurement	40
4.5.1 Limits of Power Spectral Density Measurement	40
4.5.2 Test Setup	40
4.5.3 Test Instruments	40
4.5.4 Test Procedure	40
4.5.5 Deviation from Test Standard	40
4.5.6 EUT Operating Condition	40



4.5.7 Test Results	41
4.6 Conducted Out of Band Emission Measurement	43
4.6.1 Limits of Conducted Out of Band Emission Measurement.....	43
4.6.2 Test Setup.....	43
4.6.3 Test Instruments	43
4.6.4 Test Procedure	43
4.6.5 Deviation from Test Standard	43
4.6.6 EUT Operating Condition	43
4.6.7 Test Results	44
5 Pictures of Test Arrangements.....	48
Appendix – Information on the Testing Laboratories	49



Release Control Record

Issue No.	Description	Date Issued
RF160427E04	Original release.	July 28, 2016

1 Certificate of Conformity

Product: Puzzle-B3

Brand: InnoComm

Test Model: 2213

Sample Status: ENGINEERING SAMPLE

Applicant: InnoComm Mobile Technology Corp.

Test Date: June 21 to 22, 2016

Standards: 47 CFR FCC Part 15, Subpart C (Section 15.247)
ANSI C63.10: 2013

The above equipment has been tested by **Bureau Veritas Consumer Products Services (H.K.) Ltd., Taoyuan Branch**, and found compliance with the requirement of the above standards. The test record, data evaluation & Equipment Under Test (EUT) configurations represented herein are true and accurate accounts of the measurements of the sample's EMC characteristics under the conditions specified in this report.

Prepared by :  _____, **Date:** July 28, 2016
Claire Kuan / Specialist

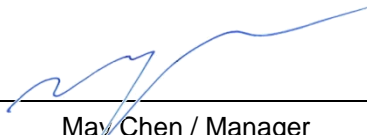
Approved by :  _____, **Date:** July 28, 2016
May Chen / Manager

2 Summary of Test Results

47 CFR FCC Part 15, Subpart C (SECTION 15.247)			
FCC Clause	Test Item	Result	Remarks
15.207	AC Power Conducted Emission	PASS	Meet the requirement of limit. Minimum passing margin is -12.01dB at 19.68988MHz.
15.205 / 15.209 / 15.247(d)	Radiated Emissions and Band Edge Measurement	PASS	Meet the requirement of limit. Minimum passing margin is -0.1dB at 2483.50MHz
15.247(d)	Antenna Port Emission	PASS	Meet the requirement of limit.
15.247(a)(2)	6dB bandwidth	PASS	Meet the requirement of limit.
15.247(b)	Conducted power	PASS	Meet the requirement of limit.
15.247(e)	Power Spectral Density	PASS	Meet the requirement of limit.
15.203	Antenna Requirement	PASS	Antenna connector is i-pex(MHF) not a standard connector.

2.1 Measurement Uncertainty

Where relevant, the following measurement uncertainty levels have been estimated for tests performed on the EUT as specified in CISPR 16-4-2:

Measurement	Frequency	Expanded Uncertainty (k=2) (±)
Conducted Emissions at mains ports	150kHz ~ 30MHz	1.83 dB
Radiated Emissions up to 1 GHz	30MHz ~ 1GHz	5.19 dB
Radiated Emissions above 1 GHz	1GHz ~ 6GHz	3.43 dB
	6GHz ~ 18GHz	3.49 dB
	18GHz ~ 40GHz	4.11 dB

2.2 Modification Record

There were no modifications required for compliance.

3 General Information

3.1 General Description of EUT

Product	Puzzle-B3
Brand	InnoComm
Test Model	2213
Status of EUT	ENGINEERING SAMPLE
Power Supply Rating	4.2Vdc
Modulation Type	CCK, DQPSK, DBPSK for DSSS 64QAM, 16QAM, QPSK, BPSK for OFDM
Modulation Technology	DSSS, OFDM
Transfer Rate	802.11b: up to 11Mbps 802.11g: up to 54Mbps 802.11n: up to 72.2Mbps
Operating Frequency	2.412 ~ 2.462GHz
Number of Channel	11
Output Power	802.11b: 149.279mW 802.11g: 360.579mW 802.11n (HT20): 345.939mW
Antenna Type	Refer to Note
Antenna Connector	Refer to Note
Accessory Device	NA
Data Cable Supplied	NA

Note:

1. The antenna provided to the EUT, please refer to the following table:

Brand	Model	Ant. Gain (dBi)	Frequency range (GHz to GHz)	Antenna Type	Antenna Connector	Cable Length(mm)
Unictron Technologies Corporation	WT217-01C	4.13	2.4~2.4835	PCB	i-pex(MHF)	100

2. The EUT incorporates a SISO function.

MODULATION MODE	DATA RATE (MCS)	TX & RX CONFIGURATION	
802.11b	1 ~ 11Mbps	1TX	1RX
802.11g	6 ~ 54Mbps	1TX	1RX
802.11n (HT20)	MCS 0~7	1TX	1RX

3. The above EUT information is declared by manufacturer and for more detailed features description, please refer to the manufacturer's specifications or user's manual.

3.2 Description of Test Modes

11 channels are provided for 802.11b, 802.11g and 802.11n (HT20):

Channel	Frequency	Channel	Frequency
1	2412MHz	7	2442MHz
2	2417MHz	8	2447MHz
3	2422MHz	9	2452MHz
4	2427MHz	10	2457MHz
5	2432MHz	11	2462MHz
6	2437MHz		

3.2.1 Test Mode Applicability and Tested Channel Detail

EUT CONFIGURE MODE	APPLICABLE TO				DESCRIPTION
	RE \geq 1G	RE<1G	PLC	APCM	
-	√	√	√	√	-

Where RE \geq 1G: Radiated Emission above 1GHz & Bandedge Measurement
 RE<1G: Radiated Emission below 1GHz
 PLC: Power Line Conducted Emission
 APCM: Antenna Port Conducted Measurement

NOTE: The EUT's antenna had been pre-tested on the positioned of each 3 axis. The worst case was found when positioned on X-plane for below 1GHz and Y-plane for above 1GHz.

Radiated Emission Test (Above 1GHz):

- Pre-Scan has been conducted to determine the worst-case mode from all possible combinations between available modulations, data rates and antenna ports (if EUT with antenna diversity architecture).
- Following channel(s) was (were) selected for the final test as listed below.

MODE	AVAILABLE CHANNEL	TESTED CHANNEL	MODULATION TECHNOLOGY	MODULATION TYPE	DATA RATE (Mbps)
802.11b	1 to 11	1, 6, 11	DSSS	DBPSK	1
802.11g	1 to 11	1, 6, 11	OFDM	BPSK	6
802.11n (HT20)	1 to 11	1, 6, 11	OFDM	BPSK	6.5

Radiated Emission Test (Below 1GHz):

- Pre-Scan has been conducted to determine the worst-case mode from all possible combinations between available modulations, data rates and antenna ports (if EUT with antenna diversity architecture).
- Following channel(s) was (were) selected for the final test as listed below.

MODE	AVAILABLE CHANNEL	TESTED CHANNEL	MODULATION TECHNOLOGY	MODULATION TYPE	DATA RATE (Mbps)
802.11g	1 to 11	6	OFDM	BPSK	6

Power Line Conducted Emission Test:

- Pre-Scan has been conducted to determine the worst-case mode from all possible combinations between available modulations, data rates and antenna ports (if EUT with antenna diversity architecture).
- Following channel(s) was (were) selected for the final test as listed below.

MODE	AVAILABLE CHANNEL	TESTED CHANNEL	MODULATION TECHNOLOGY	MODULATION TYPE	DATA RATE (Mbps)
802.11g	1 to 11	6	OFDM	BPSK	6



Antenna Port Conducted Measurement:

- This item includes all test value of each mode, but only includes spectrum plot of worst value of each mode.
- Pre-Scan has been conducted to determine the worst-case mode from all possible combinations between available modulations, data rates and antenna ports (if EUT with antenna diversity architecture).
- Following channel(s) was (were) selected for the final test as listed below.

MODE	AVAILABLE CHANNEL	TESTED CHANNEL	MODULATION TECHNOLOGY	MODULATION TYPE	DATA RATE (Mbps)
802.11b	1 to 11	1, 6, 11	DSSS	DBPSK	1
802.11g	1 to 11	1, 6, 11	OFDM	BPSK	6
802.11n (HT20)	1 to 11	1, 6, 11	OFDM	BPSK	6.5

Test Condition:

APPLICABLE TO	ENVIRONMENTAL CONDITIONS	INPUT POWER (SYSTEM)	TESTED BY
RE≥1G	22deg. C, 66%RH	120Vac, 60Hz	Russell Yeh
RE<1G	22deg. C, 66%RH	120Vac, 60Hz	Robert Cheng
PLC	24deg. C, 62%RH	120Vac, 60Hz	Jyunchun Lin
APCM	23deg. C, 66%RH	120Vac, 60Hz	Anderson Chen

3.3 Duty Cycle of Test Signal

If duty cycle of test signal is $\geq 98\%$, duty factor is not required.

If duty cycle of test signal is $< 98\%$, duty factor shall be considered.

802.11b: Duty cycle = $8.413 \text{ ms} / 8.468 \text{ ms} = 0.994$

802.11g: Duty cycle = $1.394 \text{ ms} / 1.454 \text{ ms} = 0.959$, Duty factor = $10 * \log(1/0.959) = 0.2$

802.11n (HT20): Duty cycle = $0.707 \text{ ms} / 0.759 \text{ ms} = 0.931$, Duty factor = $10 * \log(1/0.931) = 0.3$

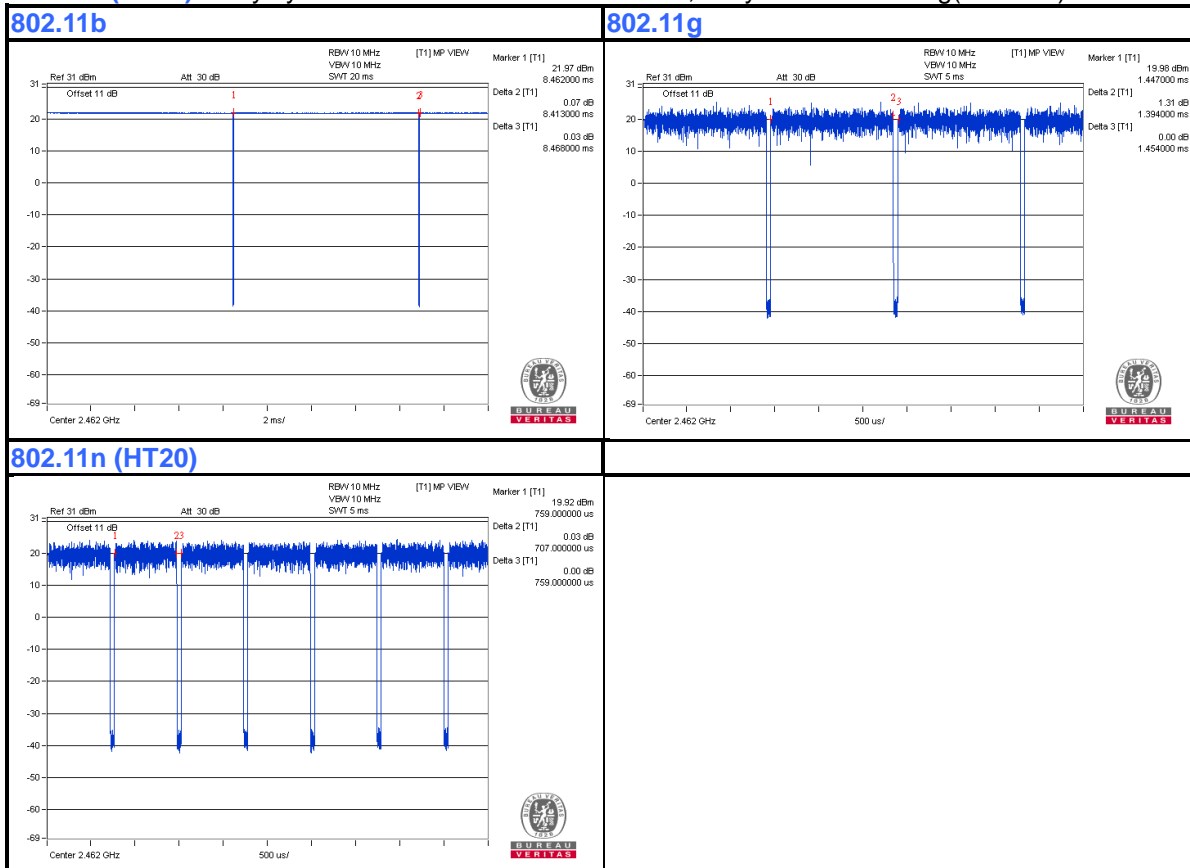



3.4 Description of Support Units

The EUT has been tested as an independent unit together with other necessary accessories or support units. The following support units or accessories were used to form a representative test configuration during the tests.

ID	Product	Brand	Model No.	Serial No.	FCC ID	Remarks
A.	Adapter	TECH	ATS050-P121	NA	NA	Supplied by Client
B.	Test Tool	AVISION	NA	NA	NA	Supplied by Client

Note:

1. All power cords of the above support units are non-shielded (1.8m).

ID	Descriptions	Qty.	Length (m)	Shielding (Yes/No)	Cores (Qty.)	Remarks
1.	AC Cable	1	1.8	NA	0	Supplied by Client
2.	DC Cable	1	1.5	NA	1	Supplied by Client

Note: The core(s) is(are) originally attached to the cable(s).

3.4.1 Configuration of System under Test

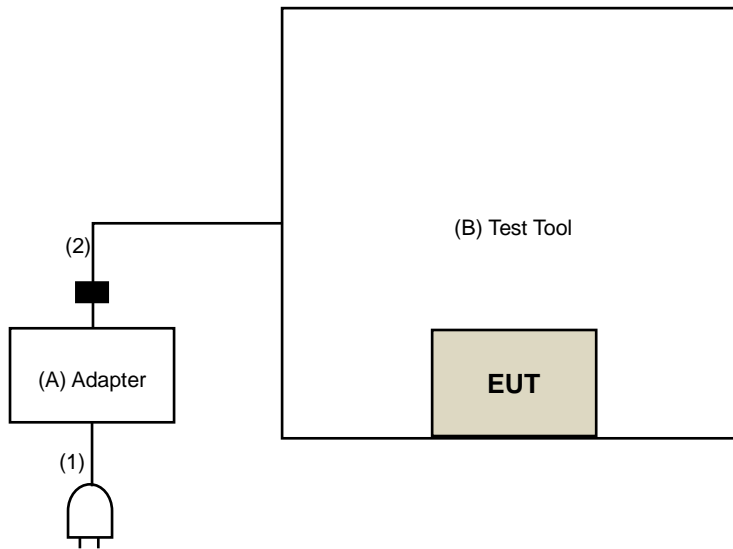

3.5 General Description of Applied Standards

The EUT is a RF Product. According to the specifications of the manufacturer, it must comply with the requirements of the following standards:

FCC Part 15, Subpart C (15.247)
KDB 558074 D01 DTS Meas Guidance v03r05
ANSI C63.10-2013

All test items have been performed and recorded as per the above standards.

4 Test Types and Results

4.1 Radiated Emission and Bandedge Measurement

4.1.1 Limits of Radiated Emission and Bandedge Measurement

Radiated emissions which fall in the restricted bands must comply with the radiated emission limits specified as below table. Other emissions shall be at least 20dB below the highest level of the desired power:

Frequencies (MHz)	Field Strength (microvolts/meter)	Measurement Distance (meters)
0.009 ~ 0.490	2400/F(kHz)	300
0.490 ~ 1.705	24000/F(kHz)	30
1.705 ~ 30.0	30	30
30 ~ 88	100	3
88 ~ 216	150	3
216 ~ 960	200	3
Above 960	500	3

NOTE:

1. The lower limit shall apply at the transition frequencies.
2. Emission level (dBuV/m) = 20 log Emission level (uV/m).
3. For frequencies above 1000MHz, the field strength limits are based on average detector, however, the peak field strength of any emission shall not exceed the maximum permitted average limits, specified above by more than 20dB under any condition of modulation.

4.1.2 Test Instruments

DESCRIPTION & MANUFACTURER	MODEL NO.	SERIAL NO.	CALIBRATED DATE	CALIBRATED UNTIL
Test Receiver Agilent	N9038A	MY54450088	July 24, 2015	July 23, 2016
Pre-Amplifier ^(*) EMCI	EMC001340	980142	Jan. 20, 2016	Jan. 19, 2018
Loop Antenna ^(*) Electro-Metrics	EM-6879	264	Dec. 16, 2014	Dec. 15, 2016
RF Cable	NA	LOOPCAB-001 LOOPCAB-002	Jan. 18, 2016	Jan. 17, 2017
Pre-Amplifier Mini-Circuits	ZFL-1000VH2 B	AMP-ZFL-01	Nov. 11, 2015	Nov. 10, 2016
Trilog Broadband Antenna SCHWARZBECK	VULB 9168	9168-406	Jan. 04, 2016	Jan. 03, 2017
RF Cable	8D	966-4-1 966-4-2 966-4-3	Apr. 02, 2016	Apr. 01, 2017
Horn_Antenna SCHWARZBECK	BBHA 9120D	9120D-783	Jan. 19, 2016	Jan. 18, 2017
Pre-Amplifier Agilent	8449B	3008A01922	Sep. 19, 2015	Sep. 18, 2016
RF Cable	EMC104-SM- SM-2000 EMC104-SM- SM-5000 EMC104-SM- SM-5000	150318 150323 150324	Mar. 30, 2016	Mar. 29, 2017
Pre-Amplifier EMCI	EMC184045	980143	Jan. 15, 2016	Jan. 14, 2017
Horn_Antenna SCHWARZBECK	BBHA 9170	BBHA9170608	Jan. 08, 2016	Jan. 07, 2017
RF Cable	SUCOFLEX 102	36432/2 36441/2	Jan. 16, 2016	Jan. 15, 2017
Software	ADT_Radiated _V8.7.07	NA	NA	NA
Antenna Tower & Turn Table Max-Full	MF-7802	MF780208410	NA	NA
Boresight Antenna Fixture	FBA-01	FBA-SIP02	NA	NA
Power meter Anritsu	ML2495A	1014008	May 05, 2016	May 04, 2017
Power sensor Anritsu	MA2411B	0917122	May 05, 2016	May 04, 2017

Note:

1. The calibration interval of the above test instruments is 12 months and the calibrations are traceable to NML/ROC and NIST/USA.
2. *The calibration interval of the above test instruments is 24 months and the calibrations are traceable to NML/ROC and NIST/USA.
3. The test was performed in 966 Chamber No. 4.
4. The FCC Site Registration No. is 292998
5. The CANADA Site Registration No. is 20331-2
6. Tested Date: June 22, 2016

4.1.3 Test Procedures

- a. The EUT was placed on the top of a rotating table 0.8 meters (for below 1GHz) / 1.5 meters (for above 1GHz) above the ground at 3 meter chamber room for test. The table was rotated 360 degrees to determine the position of the highest radiation.
- b. The EUT was set 3 meters away from the interference-receiving antenna, which was mounted on the top of a variable-height antenna tower.
- c. The height of antenna is varied from one meter to four meters above the ground to determine the maximum value of the field strength. Both horizontal and vertical polarizations of the antenna are set to make the measurement.
- d. For each suspected emission, the EUT was arranged to its worst case and then the antenna was tuned to heights from 1 meter to 4 meters and the rotatable table was turned from 0 degrees to 360 degrees to find the maximum reading.
- e. The test-receiver system was set to quasi-peak detect function and specified bandwidth with maximum hold mode when the test frequency is below 1 GHz.
- f. The test-receiver system was set to peak and average detect function and specified bandwidth with maximum hold mode when the test frequency is above 1 GHz. If the peak reading value also meets average limit, measurement with the average detector is unnecessary.

Note:

1. The resolution bandwidth and video bandwidth of test receiver/spectrum analyzer is 120kHz for Quasi-peak detection (QP) at frequency below 1GHz.
2. The resolution bandwidth of test receiver/spectrum analyzer is 1 MHz and the video bandwidth is 3 MHz for Peak detection (PK) at frequency above 1GHz.
3. The resolution bandwidth of test receiver/spectrum analyzer is 1MHz and the video bandwidth is 3MHz for RMS Average (Duty cycle < 98%) for Average detection (AV) at frequency above 1GHz, then the measurement results was added to a correction factor ($10 \log(1/\text{duty cycle})$).
4. The resolution bandwidth of test receiver/spectrum analyzer is 1MHz and the video bandwidth is 10Hz (Duty cycle \geq 98%) for Average detection (AV) at frequency above 1GHz.
5. All modes of operation were investigated and the worst-case emissions are reported.

4.1.4 Deviation from Test Standard

No deviation.

4.1.5 Test Setup

<Frequency Range below 1GHz>

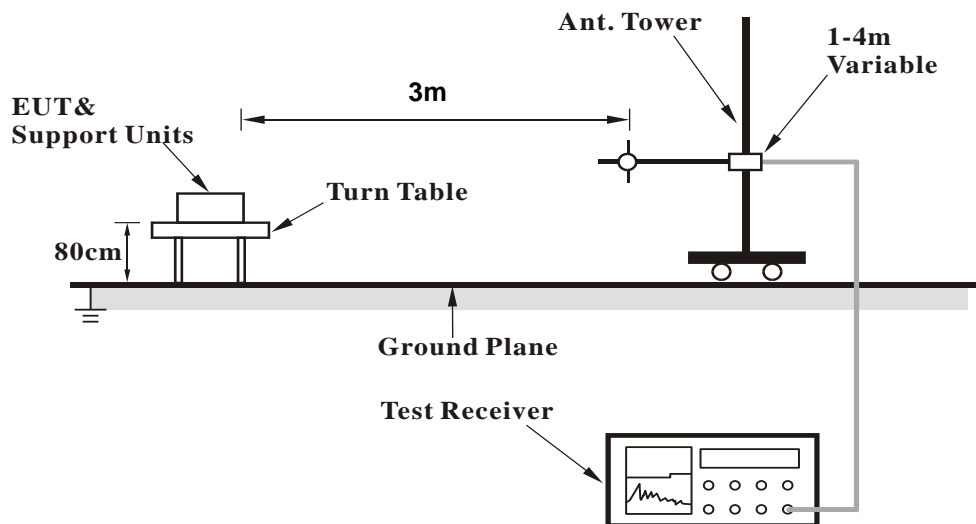

<Frequency Range above 1GHz>

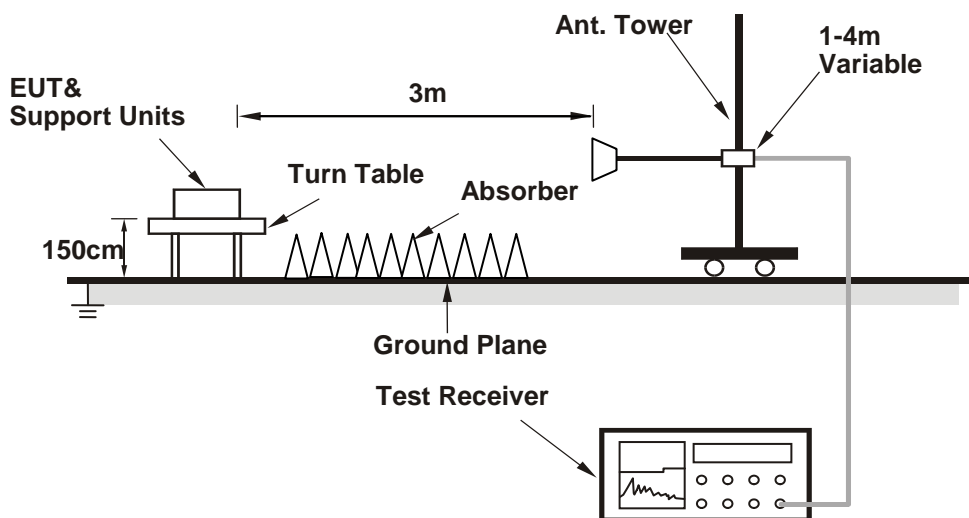

For the actual test configuration, please refer to the attached file (Test Setup Photo).

4.1.6 EUT Operating Conditions

1. Placed the EUT on testing table.
2. Controlling software (adb.exe paste "2213 RF SOP" command) has been activated to set the EUT under transmission/receiving condition continuously.

4.1.7 Test Results

Above 1GHz Data :

802.11b

CHANNEL	TX Channel 1	DETECTOR FUNCTION	Peak (PK)
FREQUENCY RANGE	1GHz ~ 25GHz		Average (AV)

ANTENNA POLARITY & TEST DISTANCE: HORIZONTAL AT 3 M

NO.	FREQ. (MHz)	EMISSION LEVEL (dBuV/m)	LIMIT (dBuV/m)	MARGIN (dB)	ANTENNA HEIGHT (m)	TABLE ANGLE (Degree)	RAW VALUE (dBuV)	CORRECTION FACTOR (dB/m)
1	2390.00	56.8 PK	74.0	-17.2	2.59 H	359	62.4	-5.6
2	2390.00	49.2 AV	54.0	-4.8	2.59 H	359	54.8	-5.6
3	*2412.00	108.8 PK			2.04 H	337	114.3	-5.5
4	*2412.00	106.3 AV			2.04 H	337	111.8	-5.5
5	4824.00	39.8 PK	74.0	-34.2	1.00 H	155	38.9	0.9
6	4824.00	28.2 AV	54.0	-25.8	1.00 H	155	27.3	0.9

ANTENNA POLARITY & TEST DISTANCE: VERTICAL AT 3 M

NO.	FREQ. (MHz)	EMISSION LEVEL (dBuV/m)	LIMIT (dBuV/m)	MARGIN (dB)	ANTENNA HEIGHT (m)	TABLE ANGLE (Degree)	RAW VALUE (dBuV)	CORRECTION FACTOR (dB/m)
1	2390.00	46.7 PK	74.0	-27.3	1.19 V	230	52.3	-5.6
2	2390.00	38.4 AV	54.0	-15.6	1.19 V	230	44.0	-5.6
3	*2412.00	101.6 PK			1.19 V	230	107.1	-5.5
4	*2412.00	98.9 AV			1.19 V	230	104.4	-5.5
5	4824.00	41.6 PK	74.0	-32.4	2.50 V	218	40.7	0.9
6	4824.00	30.4 AV	54.0	-23.6	2.50 V	218	29.5	0.9

REMARKS:

1. Emission Level(dBuV/m) = Raw Value(dBuV) + Correction Factor(dB/m)
2. Correction Factor(dB/m) = Antenna Factor(dB/m) + Cable Factor(dB) – Pre-Amplifier Factor(dB)
3. The other emission levels were very low against the limit.
4. Margin value = Emission Level – Limit value
5. " * ": Fundamental frequency.

CHANNEL	TX Channel 6	DETECTOR FUNCTION	Peak (PK)
FREQUENCY RANGE	1GHz ~ 25GHz		Average (AV)

ANTENNA POLARITY & TEST DISTANCE: HORIZONTAL AT 3 M

NO.	FREQ. (MHz)	EMISSION LEVEL (dBuV/m)	LIMIT (dBuV/m)	MARGIN (dB)	ANTENNA HEIGHT (m)	TABLE ANGLE (Degree)	RAW VALUE (dBuV)	CORRECTION FACTOR (dB/m)
1	*2437.00	109.9 PK			2.22 H	337	115.3	-5.4
2	*2437.00	107.2 AV			2.22 H	337	112.6	-5.4
3	4874.00	41.1 PK	74.0	-32.9	1.00 H	145	40.1	1.0
4	4874.00	28.4 AV	54.0	-25.6	1.00 H	145	27.4	1.0
5	7311.00	48.2 PK	74.0	-25.8	1.65 H	214	40.6	7.6
6	7311.00	35.2 AV	54.0	-18.8	1.65 H	214	27.6	7.6

ANTENNA POLARITY & TEST DISTANCE: VERTICAL AT 3 M

NO.	FREQ. (MHz)	EMISSION LEVEL (dBuV/m)	LIMIT (dBuV/m)	MARGIN (dB)	ANTENNA HEIGHT (m)	TABLE ANGLE (Degree)	RAW VALUE (dBuV)	CORRECTION FACTOR (dB/m)
1	*2437.00	102.3 PK			1.23 V	236	107.7	-5.4
2	*2437.00	99.6 AV			1.23 V	236	105.0	-5.4
3	4874.00	40.8 PK	74.0	-33.2	2.55 V	214	39.8	1.0
4	4874.00	28.9 AV	54.0	-25.1	2.55 V	214	27.9	1.0
5	7311.00	48.7 PK	74.0	-25.3	1.80 V	222	41.1	7.6
6	7311.00	35.7 AV	54.0	-18.3	1.80 V	222	28.1	7.6

REMARKS:

1. Emission Level(dBuV/m) = Raw Value(dBuV) + Correction Factor(dB/m)
2. Correction Factor(dB/m) = Antenna Factor(dB/m) + Cable Factor(dB) – Pre-Amplifier Factor(dB)
3. The other emission levels were very low against the limit.
4. Margin value = Emission Level – Limit value
5. " * ": Fundamental frequency.



CHANNEL	TX Channel 11	DETECTOR FUNCTION	Peak (PK)
FREQUENCY RANGE	1GHz ~ 25GHz		Average (AV)

ANTENNA POLARITY & TEST DISTANCE: HORIZONTAL AT 3 M

NO.	FREQ. (MHz)	EMISSION LEVEL (dBuV/m)	LIMIT (dBuV/m)	MARGIN (dB)	ANTENNA HEIGHT (m)	TABLE ANGLE (Degree)	RAW VALUE (dBuV)	CORRECTION FACTOR (dB/m)
1	*2462.00	109.1 PK			2.01 H	340	114.4	-5.3
2	*2462.00	106.5 AV			2.01 H	340	111.8	-5.3
3	2483.50	58.2 PK	74.0	-15.8	2.01 H	340	63.5	-5.3
4	2483.50	50.2 AV	54.0	-3.8	2.01 H	340	55.5	-5.3
5	4924.00	41.4 PK	74.0	-32.6	1.03 H	149	40.1	1.3
6	4924.00	28.7 AV	54.0	-25.3	1.03 H	149	27.4	1.3
7	7386.00	48.8 PK	74.0	-25.2	1.63 H	211	41.1	7.7
8	7386.00	35.3 AV	54.0	-18.7	1.63 H	211	27.6	7.7

ANTENNA POLARITY & TEST DISTANCE: VERTICAL AT 3 M

NO.	FREQ. (MHz)	EMISSION LEVEL (dBuV/m)	LIMIT (dBuV/m)	MARGIN (dB)	ANTENNA HEIGHT (m)	TABLE ANGLE (Degree)	RAW VALUE (dBuV)	CORRECTION FACTOR (dB/m)
1	*2462.00	101.7 PK			1.23 V	225	107.0	-5.3
2	*2462.00	99.2 AV			1.23 V	225	104.5	-5.3
3	2483.50	46.7 PK	74.0	-27.3	1.23 V	225	52.0	-5.3
4	2483.50	38.3 AV	54.0	-15.7	1.23 V	225	43.6	-5.3
5	4924.00	41.1 PK	74.0	-32.9	2.58 V	210	39.8	1.3
6	4924.00	29.2 AV	54.0	-24.8	2.58 V	210	27.9	1.3
7	7386.00	48.9 PK	74.0	-25.1	1.87 V	210	41.2	7.7
8	7386.00	35.8 AV	54.0	-18.2	1.87 V	210	28.1	7.7

REMARKS:

1. Emission Level(dBuV/m) = Raw Value(dBuV) + Correction Factor(dB/m)
2. Correction Factor(dB/m) = Antenna Factor(dB/m) + Cable Factor(dB) – Pre-Amplifier Factor(dB)
3. The other emission levels were very low against the limit.
4. Margin value = Emission Level – Limit value
5. " * ": Fundamental frequency.



802.11g

CHANNEL	TX Channel 1	DETECTOR FUNCTION	Peak (PK)
FREQUENCY RANGE	1GHz ~ 25GHz		Average (AV)

ANTENNA POLARITY & TEST DISTANCE: HORIZONTAL AT 3 M

NO.	FREQ. (MHz)	EMISSION LEVEL (dBuV/m)	LIMIT (dBuV/m)	MARGIN (dB)	ANTENNA HEIGHT (m)	TABLE ANGLE (Degree)	RAW VALUE (dBuV)	CORRECTION FACTOR (dB/m)
1	2390.00	73.4 PK	74.0	-0.6	2.62 H	335	79.0	-5.6
2	2390.00	50.7 AV	54.0	-3.3	2.62 H	335	56.3	-5.6
3	*2412.00	110.9 PK			2.62 H	335	116.4	-5.5
4	*2412.00	98.6 AV			2.62 H	335	104.1	-5.5
5	4824.00	40.2 PK	74.0	-33.8	1.00 H	153	39.3	0.9
6	4824.00	28.7 AV	54.0	-25.3	1.00 H	153	27.8	0.9

ANTENNA POLARITY & TEST DISTANCE: VERTICAL AT 3 M

NO.	FREQ. (MHz)	EMISSION LEVEL (dBuV/m)	LIMIT (dBuV/m)	MARGIN (dB)	ANTENNA HEIGHT (m)	TABLE ANGLE (Degree)	RAW VALUE (dBuV)	CORRECTION FACTOR (dB/m)
1	2390.00	66.4 PK	74.0	-7.6	1.19 V	237	72.0	-5.6
2	2390.00	44.2 AV	54.0	-9.8	1.19 V	237	49.8	-5.6
3	*2412.00	103.2 PK			1.19 V	237	108.7	-5.5
4	*2412.00	91.1 AV			1.19 V	237	96.6	-5.5
5	4824.00	40.8 PK	74.0	-33.2	2.58 V	208	39.9	0.9
6	4824.00	29.2 AV	54.0	-24.8	2.58 V	208	28.3	0.9

REMARKS:

1. Emission Level(dBuV/m) = Raw Value(dBuV) + Correction Factor(dB/m)
2. Correction Factor(dB/m) = Antenna Factor(dB/m) + Cable Factor(dB) – Pre-Amplifier Factor(dB)
3. The other emission levels were very low against the limit.
4. Margin value = Emission Level – Limit value
5. " * ": Fundamental frequency.

CHANNEL	TX Channel 6	DETECTOR FUNCTION	Peak (PK)
FREQUENCY RANGE	1GHz ~ 25GHz		Average (AV)

ANTENNA POLARITY & TEST DISTANCE: HORIZONTAL AT 3 M

NO.	FREQ. (MHz)	EMISSION LEVEL (dBuV/m)	LIMIT (dBuV/m)	MARGIN (dB)	ANTENNA HEIGHT (m)	TABLE ANGLE (Degree)	RAW VALUE (dBuV)	CORRECTION FACTOR (dB/m)
1	2390.00	55.8 PK	74.0	-18.2	2.22 H	336	61.4	-5.6
2	2390.00	38.8 AV	54.0	-15.2	2.22 H	336	44.4	-5.6
3	*2437.00	113.6 PK			2.22 H	336	119.0	-5.4
4	*2437.00	100.6 AV			2.22 H	336	106.0	-5.4
5	2483.50	57.6 PK	74.0	-16.4	2.22 H	336	62.9	-5.3
6	2483.50	40.5 AV	54.0	-13.5	2.22 H	336	45.8	-5.3
7	4874.00	41.5 PK	74.0	-32.5	1.03 H	148	40.5	1.0
8	4874.00	29.1 AV	54.0	-24.9	1.03 H	148	28.1	1.0
9	7311.00	48.8 PK	74.0	-25.2	1.71 H	211	41.2	7.6
10	7311.00	36.4 AV	54.0	-17.6	1.71 H	211	28.8	7.6

ANTENNA POLARITY & TEST DISTANCE: VERTICAL AT 3 M

NO.	FREQ. (MHz)	EMISSION LEVEL (dBuV/m)	LIMIT (dBuV/m)	MARGIN (dB)	ANTENNA HEIGHT (m)	TABLE ANGLE (Degree)	RAW VALUE (dBuV)	CORRECTION FACTOR (dB/m)
1	2390.00	51.9 PK	74.0	-22.1	1.19 V	231	57.5	-5.6
2	2390.00	38.1 AV	54.0	-15.9	1.19 V	231	43.7	-5.6
3	*2437.00	105.6 PK			1.19 V	231	111.0	-5.4
4	*2437.00	93.4 AV			1.19 V	231	98.8	-5.4
5	2483.50	53.5 PK	74.0	-20.5	1.19 V	231	58.8	-5.3
6	2483.50	39.9 AV	54.0	-14.1	1.19 V	231	45.2	-5.3
7	4874.00	40.7 PK	74.0	-33.3	2.61 V	195	39.7	1.0
8	4874.00	29.1 AV	54.0	-24.9	2.61 V	195	28.1	1.0
9	7311.00	48.9 PK	74.0	-25.1	1.87 V	217	41.3	7.6
10	7311.00	35.9 AV	54.0	-18.1	1.87 V	217	28.3	7.6

REMARKS:

1. Emission Level(dBuV/m) = Raw Value(dBuV) + Correction Factor(dB/m)
2. Correction Factor(dB/m) = Antenna Factor(dB/m) + Cable Factor(dB) – Pre-Amplifier Factor(dB)
3. The other emission levels were very low against the limit.
4. Margin value = Emission Level – Limit value
5. " * ": Fundamental frequency.



CHANNEL	TX Channel 11	DETECTOR FUNCTION	Peak (PK)
FREQUENCY RANGE	1GHz ~ 25GHz		Average (AV)

ANTENNA POLARITY & TEST DISTANCE: HORIZONTAL AT 3 M

NO.	FREQ. (MHz)	EMISSION LEVEL (dBuV/m)	LIMIT (dBuV/m)	MARGIN (dB)	ANTENNA HEIGHT (m)	TABLE ANGLE (Degree)	RAW VALUE (dBuV)	CORRECTION FACTOR (dB/m)
1	*2462.00	111.7 PK			2.17 H	337	117.0	-5.3
2	*2462.00	99.2 AV			2.17 H	337	104.5	-5.3
3	2483.50	73.9 PK	74.0	-0.1	2.17 H	337	79.2	-5.3
4	2483.50	50.2 AV	54.0	-3.8	2.17 H	337	55.5	-5.3
5	4924.00	41.6 PK	74.0	-32.4	1.07 H	157	40.3	1.3
6	4924.00	29.4 AV	54.0	-24.6	1.07 H	157	28.1	1.3
7	7386.00	55.9 PK	74.0	-18.1	1.64 H	218	48.2	7.7
8	7386.00	39.3 AV	54.0	-14.7	1.64 H	218	31.6	7.7

ANTENNA POLARITY & TEST DISTANCE: VERTICAL AT 3 M

NO.	FREQ. (MHz)	EMISSION LEVEL (dBuV/m)	LIMIT (dBuV/m)	MARGIN (dB)	ANTENNA HEIGHT (m)	TABLE ANGLE (Degree)	RAW VALUE (dBuV)	CORRECTION FACTOR (dB/m)
1	*2462.00	103.4 PK			1.22 V	233	108.7	-5.3
2	*2462.00	91.0 AV			1.22 V	233	96.3	-5.3
3	2483.50	66.3 PK	74.0	-7.7	1.22 V	233	71.6	-5.3
4	2483.50	44.3 AV	54.0	-9.7	1.22 V	233	49.6	-5.3
5	4924.00	41.7 PK	74.0	-32.3	2.57 V	196	40.4	1.3
6	4924.00	29.6 AV	54.0	-24.4	2.57 V	196	28.3	1.3
7	7386.00	49.3 PK	74.0	-24.7	1.82 V	210	41.6	7.7
8	7386.00	36.2 AV	54.0	-17.8	1.82 V	210	28.5	7.7

REMARKS:

1. Emission Level(dBuV/m) = Raw Value(dBuV) + Correction Factor(dB/m)
2. Correction Factor(dB/m) = Antenna Factor(dB/m) + Cable Factor(dB) – Pre-Amplifier Factor(dB)
3. The other emission levels were very low against the limit.
4. Margin value = Emission Level – Limit value
5. " * ": Fundamental frequency.

802.11n (HT20)

CHANNEL	TX Channel 1	DETECTOR FUNCTION	Peak (PK)
FREQUENCY RANGE	1GHz ~ 25GHz		Average (AV)

ANTENNA POLARITY & TEST DISTANCE: HORIZONTAL AT 3 M

NO.	FREQ. (MHz)	EMISSION LEVEL (dBuV/m)	LIMIT (dBuV/m)	MARGIN (dB)	ANTENNA HEIGHT (m)	TABLE ANGLE (Degree)	RAW VALUE (dBuV)	CORRECTION FACTOR (dB/m)
1	2390.00	72.2 PK	74.0	-1.8	2.04 H	352	77.8	-5.6
2	2390.00	48.5 AV	54.0	-5.5	2.04 H	352	54.1	-5.6
3	*2412.00	111.7 PK			2.04 H	352	117.2	-5.5
4	*2412.00	97.3 AV			2.04 H	352	102.8	-5.5
5	4824.00	41.6 PK	74.0	-32.4	1.01 H	138	40.7	0.9
6	4824.00	29.3 AV	54.0	-24.7	1.01 H	138	28.4	0.9

ANTENNA POLARITY & TEST DISTANCE: VERTICAL AT 3 M

NO.	FREQ. (MHz)	EMISSION LEVEL (dBuV/m)	LIMIT (dBuV/m)	MARGIN (dB)	ANTENNA HEIGHT (m)	TABLE ANGLE (Degree)	RAW VALUE (dBuV)	CORRECTION FACTOR (dB/m)
1	2390.00	65.7 PK	74.0	-8.3	1.27 V	236	71.3	-5.6
2	2390.00	43.7 AV	54.0	-10.3	1.27 V	236	49.3	-5.6
3	*2412.00	103.6 PK			1.27 V	236	109.1	-5.5
4	*2412.00	91.2 AV			1.27 V	236	96.7	-5.5
5	4824.00	41.8 PK	74.0	-32.2	2.64 V	212	40.9	0.9
6	4824.00	29.7 AV	54.0	-24.3	2.64 V	212	28.8	0.9

REMARKS:

1. Emission Level(dBuV/m) = Raw Value(dBuV) + Correction Factor(dB/m)
2. Correction Factor(dB/m) = Antenna Factor(dB/m) + Cable Factor(dB) – Pre-Amplifier Factor(dB)
3. The other emission levels were very low against the limit.
4. Margin value = Emission Level – Limit value
5. " * ": Fundamental frequency.

CHANNEL	TX Channel 6	DETECTOR FUNCTION	Peak (PK)
FREQUENCY RANGE	1GHz ~ 25GHz		Average (AV)

ANTENNA POLARITY & TEST DISTANCE: HORIZONTAL AT 3 M

NO.	FREQ. (MHz)	EMISSION LEVEL (dBuV/m)	LIMIT (dBuV/m)	MARGIN (dB)	ANTENNA HEIGHT (m)	TABLE ANGLE (Degree)	RAW VALUE (dBuV)	CORRECTION FACTOR (dB/m)
1	2390.00	52.1 PK	74.0	-21.9	2.06 H	348	57.7	-5.6
2	2390.00	38.2 AV	54.0	-15.8	2.06 H	348	43.8	-5.6
3	*2437.00	113.2 PK			2.06 H	348	118.6	-5.4
4	*2437.00	98.2 AV			2.06 H	348	103.6	-5.4
5	2483.50	53.2 PK	74.0	-20.8	2.06 H	348	58.5	-5.3
6	2483.50	39.8 AV	54.0	-14.2	2.06 H	348	45.1	-5.3
7	4874.00	40.7 PK	74.0	-33.3	1.07 H	146	39.7	1.0
8	4874.00	28.6 AV	54.0	-25.4	1.07 H	146	27.6	1.0
9	7311.00	49.2 PK	74.0	-24.8	1.67 H	209	41.6	7.6
10	7311.00	36.6 AV	54.0	-17.4	1.67 H	209	29.0	7.6

ANTENNA POLARITY & TEST DISTANCE: VERTICAL AT 3 M

NO.	FREQ. (MHz)	EMISSION LEVEL (dBuV/m)	LIMIT (dBuV/m)	MARGIN (dB)	ANTENNA HEIGHT (m)	TABLE ANGLE (Degree)	RAW VALUE (dBuV)	CORRECTION FACTOR (dB/m)
1	2390.00	52.6 PK	74.0	-21.4	1.21 V	236	58.2	-5.6
2	2390.00	38.7 AV	54.0	-15.3	1.21 V	236	44.3	-5.6
3	*2437.00	103.5 PK			1.21 V	236	108.9	-5.4
4	*2437.00	91.3 AV			1.21 V	236	96.7	-5.4
5	2483.50	53.8 PK	74.0	-20.2	1.21 V	236	59.1	-5.3
6	2483.50	40.2 AV	54.0	-13.8	1.21 V	236	45.5	-5.3
7	4874.00	41.6 PK	74.0	-32.4	2.57 V	225	40.6	1.0
8	4874.00	29.6 AV	54.0	-24.4	2.57 V	225	28.6	1.0
9	7311.00	49.0 PK	74.0	-25.0	1.84 V	217	41.4	7.6
10	7311.00	35.9 AV	54.0	-18.1	1.84 V	217	28.3	7.6

REMARKS:

1. Emission Level(dBuV/m) = Raw Value(dBuV) + Correction Factor(dB/m)
2. Correction Factor(dB/m) = Antenna Factor(dB/m) + Cable Factor(dB) – Pre-Amplifier Factor(dB)
3. The other emission levels were very low against the limit.
4. Margin value = Emission Level – Limit value
5. " * ": Fundamental frequency.

CHANNEL	TX Channel 11	DETECTOR FUNCTION	Peak (PK)
FREQUENCY RANGE	1GHz ~ 25GHz		Average (AV)

ANTENNA POLARITY & TEST DISTANCE: HORIZONTAL AT 3 M

NO.	FREQ. (MHz)	EMISSION LEVEL (dBuV/m)	LIMIT (dBuV/m)	MARGIN (dB)	ANTENNA HEIGHT (m)	TABLE ANGLE (Degree)	RAW VALUE (dBuV)	CORRECTION FACTOR (dB/m)
1	*2462.00	113.1 PK			1.86 H	338	118.4	-5.3
2	*2462.00	97.7 AV			1.86 H	338	103.0	-5.3
3	2483.50	71.7 PK	74.0	-2.3	1.86 H	338	77.0	-5.3
4	2483.50	48.7 AV	54.0	-5.3	1.86 H	338	54.0	-5.3
5	4924.00	41.5 PK	74.0	-32.5	1.09 H	142	40.2	1.3
6	4924.00	29.3 AV	54.0	-24.7	1.09 H	142	28.0	1.3
7	7386.00	49.4 PK	74.0	-24.6	1.67 H	201	41.7	7.7
8	7386.00	36.9 AV	54.0	-17.1	1.67 H	201	29.2	7.7

ANTENNA POLARITY & TEST DISTANCE: VERTICAL AT 3 M

NO.	FREQ. (MHz)	EMISSION LEVEL (dBuV/m)	LIMIT (dBuV/m)	MARGIN (dB)	ANTENNA HEIGHT (m)	TABLE ANGLE (Degree)	RAW VALUE (dBuV)	CORRECTION FACTOR (dB/m)
1	*2462.00	103.0 PK			1.25 V	239	108.3	-5.3
2	*2462.00	91.2 AV			1.25 V	239	96.5	-5.3
3	2483.50	66.4 PK	74.0	-7.6	1.25 V	239	71.7	-5.3
4	2483.50	44.1 AV	54.0	-9.9	1.25 V	239	49.4	-5.3
5	4924.00	41.4 PK	74.0	-32.6	2.58 V	196	40.1	1.3
6	4924.00	29.5 AV	54.0	-24.5	2.58 V	196	28.2	1.3
7	7386.00	49.2 PK	74.0	-24.8	1.92 V	208	41.5	7.7
8	7386.00	36.2 AV	54.0	-17.8	1.92 V	208	28.5	7.7

REMARKS:

1. Emission Level(dBuV/m) = Raw Value(dBuV) + Correction Factor(dB/m)
2. Correction Factor(dB/m) = Antenna Factor(dB/m) + Cable Factor(dB) – Pre-Amplifier Factor(dB)
3. The other emission levels were very low against the limit.
4. Margin value = Emission Level – Limit value
5. " * ": Fundamental frequency.

Below 1GHz Data

802.11g

CHANNEL	TX Channel 6	DETECTOR FUNCTION	Quasi-Peak (QP)
FREQUENCY RANGE	Below 1GHz		

ANTENNA POLARITY & TEST DISTANCE: HORIZONTAL AT 3 M

NO.	FREQ. (MHz)	EMISSION LEVEL (dBuV/m)	LIMIT (dBuV/m)	MARGIN (dB)	ANTENNA HEIGHT (m)	TABLE ANGLE (Degree)	RAW VALUE (dBuV)	CORRECTION FACTOR (dB/m)
1	30.95	27.6 QP	40.0	-12.4	1.00 H	174	37.5	-9.9
2	204.77	33.5 QP	43.5	-10.0	1.00 H	96	45.4	-11.9
3	256.01	31.7 QP	46.0	-14.3	1.00 H	360	41.4	-9.7
4	358.42	29.3 QP	46.0	-16.7	1.00 H	289	35.9	-6.6
5	665.62	32.8 QP	46.0	-13.2	1.00 H	10	32.6	0.2
6	768.00	34.3 QP	46.0	-11.7	1.00 H	162	32.2	2.1

ANTENNA POLARITY & TEST DISTANCE: VERTICAL AT 3 M

NO.	FREQ. (MHz)	EMISSION LEVEL (dBuV/m)	LIMIT (dBuV/m)	MARGIN (dB)	ANTENNA HEIGHT (m)	TABLE ANGLE (Degree)	RAW VALUE (dBuV)	CORRECTION FACTOR (dB/m)
1	30.97	30.2 QP	40.0	-9.8	1.00 V	285	40.1	-9.9
2	57.31	28.6 QP	40.0	-11.4	1.00 V	261	37.6	-9.0
3	153.63	25.7 QP	43.5	-17.8	1.00 V	214	34.1	-8.4
4	204.77	30.8 QP	43.5	-12.7	1.00 V	262	42.7	-11.9
5	256.01	27.5 QP	46.0	-18.5	1.50 V	360	37.2	-9.7
6	665.59	29.3 QP	46.0	-16.8	1.00 V	244	29.0	0.2

REMARKS:

1. Emission Level(dBuV/m) = Raw Value(dBuV) + Correction Factor(dB/m)
2. Correction Factor(dB/m) = Antenna Factor(dB/m) + Cable Factor(dB) – Pre-Amplifier Factor(dB)
3. The other emission levels were very low against the limit.
4. Margin value = Emission Level – Limit value

4.2 Conducted Emission Measurement

4.2.1 Limits of Conducted Emission Measurement

Frequency (MHz)	Conducted Limit (dBuV)	
	Quasi-peak	Average
0.15 - 0.5	66 - 56	56 - 46
0.50 - 5.0	56	46
5.0 - 30.0	60	50

Note: 1. The lower limit shall apply at the transition frequencies.

2. The limit decreases in line with the logarithm of the frequency in the range of 0.15 to 0.50MHz.

4.2.2 Test Instruments

DESCRIPTION & MANUFACTURER	MODEL NO.	SERIAL NO.	CALIBRATED DATE	CALIBRATED UNTIL
Test Receiver R&S	ESCS 30	847124/029	Oct. 23, 2015	Oct. 22, 2016
Line-Impedance Stabilization Network (for EUT) R&S	ESH3-Z5	848773/004	Oct. 28, 2015	Oct. 27, 2016
RF Cable	5D-FB	COACAB-002	Mar. 04, 2016	Mar. 03, 2017
10 dB PAD Mini-Circuits	HAT-10+	CONATT-004	Jun. 20, 2016	Jun. 19, 2017
Software BVADT	BVADT_Cond_ V7.3.7.3	NA	NA	NA

Note:

1. The calibration interval of the above test instruments are 12 months and the calibrations are traceable to NML/ROC and NIST/USA.
2. The test was performed in Shielded Room No. 1.
3. Tested Date: June 22, 2016

4.2.3 Test Procedures

- a. The EUT was placed 0.4 meters from the conducting wall of the shielded room with EUT being connected to the power mains through a line impedance stabilization network (LISN). Other support units were connected to the power mains through another LISN. The two LISNs provide 50 ohm/ 50uH of coupling impedance for the measuring instrument.
- b. Both lines of the power mains connected to the EUT were checked for maximum conducted interference.
- c. The frequency range from 150kHz to 30MHz was searched. Emission levels under (Limit - 20dB) was not recorded.

NOTE: The resolution bandwidth and video bandwidth of test receiver is 9kHz for quasi-peak detection (QP) and average detection (AV) at frequency 0.15MHz-30MHz.

4.2.4 Deviation from Test Standard

No deviation.

4.2.5 Test Setup

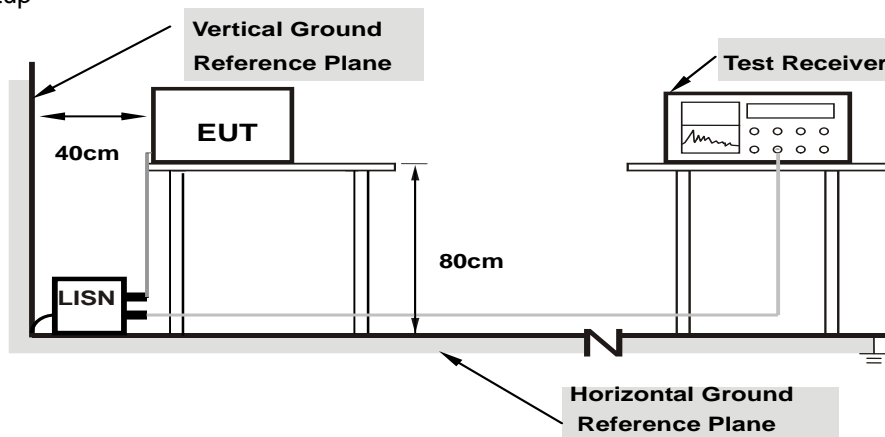

Note: 1. Support units were connected to second LISN.

For the actual test configuration, please refer to the attached file (Test Setup Photo).

4.2.6 EUT Operating Conditions

Same as 4.1.6.

4.2.7 Test Results

Phase	Line (L)	Detector Function	Quasi-Peak (QP) / Average (AV)
-------	----------	-------------------	--------------------------------

No	Freq. [MHz]	Corr. Factor	Reading Value [dB (uV)]		Emission Level [dB (uV)]		Limit [dB (uV)]		Margin (dB)	
		(dB)	Q.P.	AV.	Q.P.	AV.	Q.P.	AV.	Q.P.	AV.
	1	0.15000	10.21	28.18	10.81	38.39	21.02	66.00	56.00	-27.61
2	0.21641	10.22	20.86	5.80	31.08	16.02	62.96	52.96	-31.88	-36.94
3	0.42734	10.22	12.59	3.33	22.81	13.55	57.30	47.30	-34.49	-33.75
4	0.55625	10.23	17.25	4.27	27.48	14.50	56.00	46.00	-28.52	-31.50
5	19.68988	11.33	27.62	26.66	38.95	37.99	60.00	50.00	-21.05	-12.01
6	24.00000	11.43	24.55	23.07	35.98	34.50	60.00	50.00	-24.02	-15.50

REMARKS:

1. Q.P. and AV. are abbreviations of quasi-peak and average individually.
2. The emission levels of other frequencies were very low against the limit.
3. Margin value = Emission level - Limit value
4. Correction factor = Insertion loss + Cable loss
5. Emission Level = Correction Factor + Reading Value.

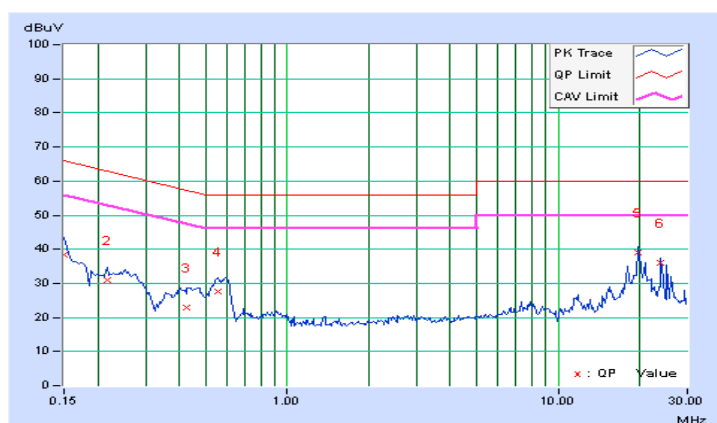

Phase	Neutral (N)	Detector Function	Quasi-Peak (QP) / Average (AV)
-------	-------------	-------------------	--------------------------------

No	Freq. [MHz]	Corr.	Reading Value		Emission Level		Limit		Margin	
		Factor	[dB (uV)]		[dB (uV)]		[dB (uV)]		(dB)	
		(dB)	Q.P.	AV.	Q.P.	AV.	Q.P.	AV.	Q.P.	AV.
1	0.15391	10.19	32.33	10.91	42.52	21.10	65.79	55.79	-23.26	-34.68
2	0.20859	10.21	20.57	5.28	30.78	15.49	63.26	53.26	-32.48	-37.77
3	0.26328	10.21	17.02	4.09	27.23	14.30	61.33	51.33	-34.10	-37.03
4	0.59141	10.21	12.46	3.30	22.67	13.51	56.00	46.00	-33.33	-32.49
5	19.82031	11.11	27.58	25.18	38.69	36.29	60.00	50.00	-21.31	-13.71
6	24.00000	11.13	26.73	26.07	37.86	37.20	60.00	50.00	-22.14	-12.80

REMARKS:

1. Q.P. and AV. are abbreviations of quasi-peak and average individually.
2. The emission levels of other frequencies were very low against the limit.
3. Margin value = Emission level - Limit value
4. Correction factor = Insertion loss + Cable loss
5. Emission Level = Correction Factor + Reading Value.

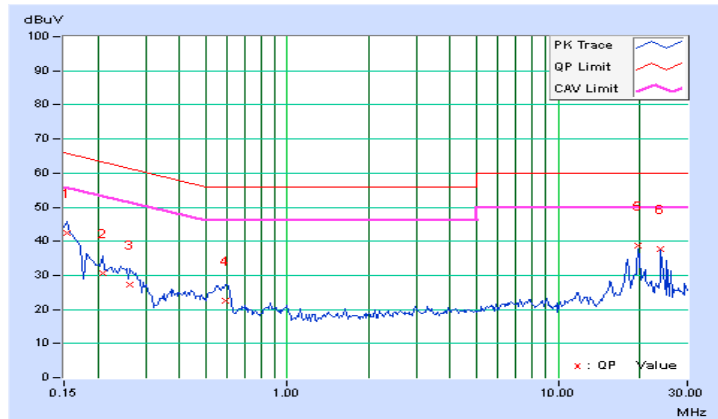

4.3 6dB Bandwidth Measurement

4.3.1 Limits of 6dB Bandwidth Measurement

The minimum of 6dB Bandwidth Measurement is 0.5 MHz.

4.3.2 Test Setup

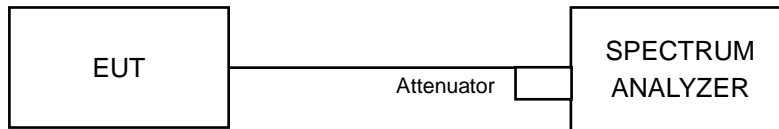

4.3.3 Test Instruments

Refer to section 4.1.2 to get information of above instrument.

4.3.4 Test Procedure

- a. Set resolution bandwidth (RBW) = 100kHz
- b. Set the video bandwidth (VBW) $\geq 3 \times$ RBW, Detector = Peak.
- c. Trace mode = max hold.
- d. Sweep = auto couple.
- e. Measure the maximum width of the emission that is constrained by the frequencies associated with the two amplitude points (upper and lower) that are attenuated by 6 dB relative to the maximum level measured in the fundamental emission

4.3.5 Deviation from Test Standard

No deviation.

4.3.6 EUT Operating Conditions

The software provided by client to enable the EUT under transmission condition continuously at lowest, middle and highest channel frequencies individually.

4.3.7 Test Result

802.11b

Channel	Frequency (MHz)	6dB Bandwidth (MHz)	Minimum Limit (MHz)	Pass / Fail
1	2412	9.57	0.5	PASS
6	2437	9.13	0.5	PASS
11	2462	9.13	0.5	PASS

802.11g

Channel	Frequency (MHz)	6dB Bandwidth (MHz)	Minimum Limit (MHz)	Pass / Fail
1	2412	15.15	0.5	PASS
6	2437	15.13	0.5	PASS
11	2462	15.17	0.5	PASS

802.11n (HT20)

Channel	Frequency (MHz)	6dB Bandwidth (MHz)	Minimum Limit (MHz)	Pass / Fail
1	2412	15.18	0.5	Pass
6	2437	15.18	0.5	Pass
11	2462	15.19	0.5	Pass



Spectrum Plot of Worst Value

802.11b / CH11

802.11g / CH6

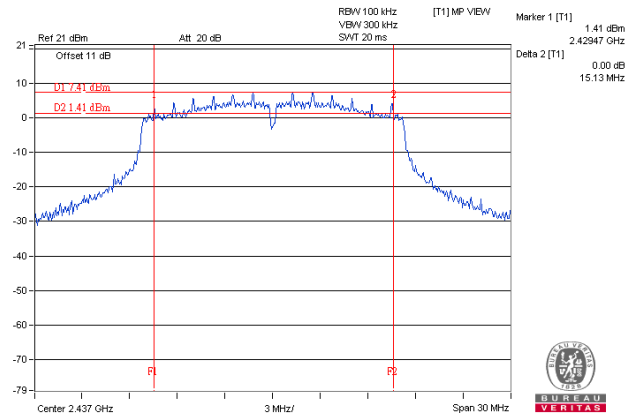
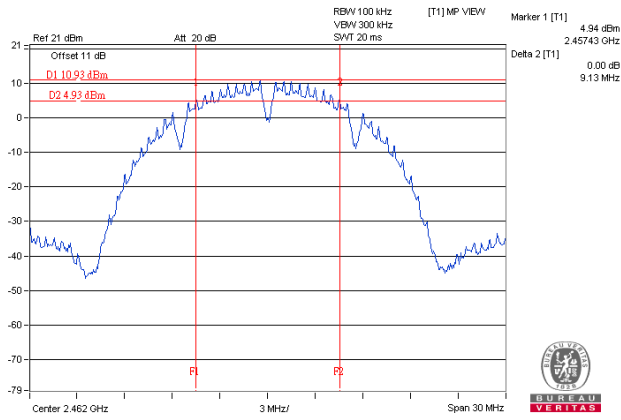

802.11n (HT20) / CH6

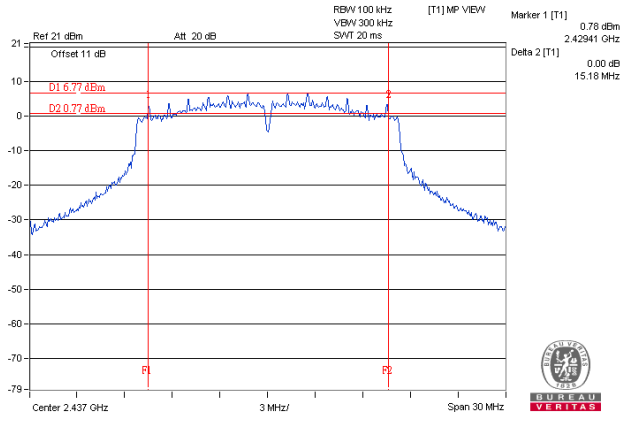

4.4 Conducted Output Power Measurement

4.4.1 Limits of Conducted Output Power Measurement

For systems using digital modulation in the 2400–2483.5 MHz bands: 1 Watt (30dBm)

4.4.2 Test Setup

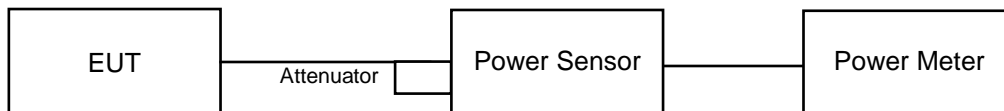

4.4.3 Test Instruments

Refer to section 4.1.2 to get information of above instrument.

4.4.4 Test Procedures

A peak / average power sensor was used on the output port of the EUT. A power meter was used to read the response of the peak / average power sensor. Record the power level.

4.4.5 Deviation from Test Standard

No deviation.

4.4.6 EUT Operating Conditions

Same as Item 4.3.6.

4.4.7 Test Results

FOR PEAK POWER

802.11b

Channel	Frequency (MHz)	Peak Power (mW)	Peak Power (dBm)	Limit (dBm)	Pass/Fail
1	2412	143.219	21.56	30	Pass
6	2437	140.929	21.49	30	Pass
11	2462	149.279	21.74	30	Pass

802.11g

Channel	Frequency (MHz)	Peak Power (mW)	Peak Power (dBm)	Limit (dBm)	Pass/Fail
1	2412	351.56	25.46	30	Pass
6	2437	360.579	25.57	30	Pass
11	2462	327.341	25.15	30	Pass

802.11n (HT20)

Channel	Frequency (MHz)	Peak Power (mW)	Peak Power (dBm)	Limit (dBm)	Pass/Fail
1	2412	345.939	25.39	30	Pass
6	2437	338.065	25.29	30	Pass
11	2462	329.61	25.18	30	Pass

FOR AVERAGE POWER
802.11b

Channel	Frequency (MHz)	Average Power (mW)	Average Power (dBm)
1	2412	82.035	19.14
6	2437	85.114	19.30
11	2462	90.157	19.55

802.11g

Channel	Frequency (MHz)	Average Power (mW)	Average Power (dBm)
1	2412	59.704	17.76
6	2437	61.802	17.91
11	2462	57.28	17.58

802.11n (HT20)

Channel	Frequency (MHz)	Average Power (mW)	Average Power (dBm)
1	2412	51.286	17.10
6	2437	52.24	17.18
11	2462	54.702	17.38

4.5 Power Spectral Density Measurement

4.5.1 Limits of Power Spectral Density Measurement

The Maximum of Power Spectral Density Measurement is 8dBm.

4.5.2 Test Setup

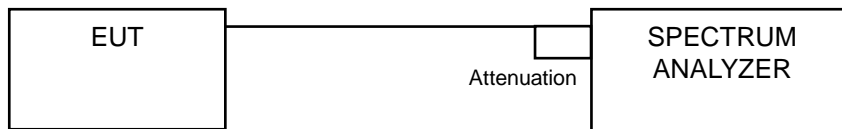

4.5.3 Test Instruments

Refer to section 4.1.2 to get information of above instrument.

4.5.4 Test Procedure

- a. Set analyzer center frequency to DTS channel center frequency.
- b. Set the span to 1.5 times the DTS bandwidth.
- c. Set the RBW to: $3 \text{ kHz} \leq \text{RBW} \leq 100 \text{ kHz}$.
- d. Set the VBW $\geq 3 \times \text{RBW}$.
- e. Detector = peak.
- f. Sweep time = auto couple.
- g. Trace mode = max hold.
- h. Allow trace to fully stabilize.
- i. Use the peak marker function to determine the maximum amplitude level within the RBW.

4.5.5 Deviation from Test Standard

No deviation.

4.5.6 EUT Operating Condition

Same as Item 4.3.6

4.5.7 Test Results

802.11b

Channel	Freq. (MHz)	PSD (dBm/3kHz)	Limit (dBm/3kHz)	Pass /Fail
1	2412	-4.35	8	Pass
6	2437	-3.81	8	Pass
11	2462	-2.77	8	Pass

802.11g

Channel	Freq. (MHz)	PSD (dBm/3kHz)	Limit (dBm/3kHz)	Pass /Fail
1	2412	-7.13	8	Pass
6	2437	-7.70	8	Pass
11	2462	-8.36	8	Pass

802.11n (HT20)

Channel	Freq. (MHz)	PSD (dBm/3kHz)	Limit (dBm/3kHz)	Pass /Fail
1	2412	-6.76	8	Pass
6	2437	-7.67	8	Pass
11	2462	-7.25	8	Pass



Spectrum Plot of Worst Value

802.11b / CH1

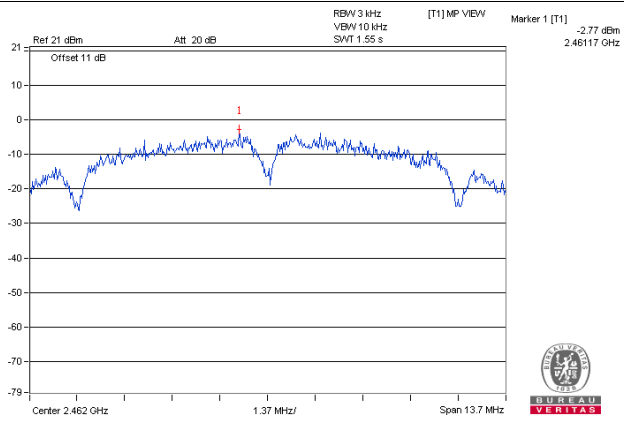

802.11g / CH1

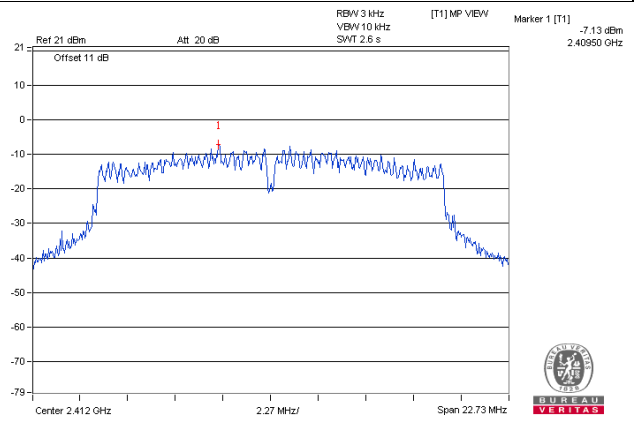

802.11n (HT20) / CH1

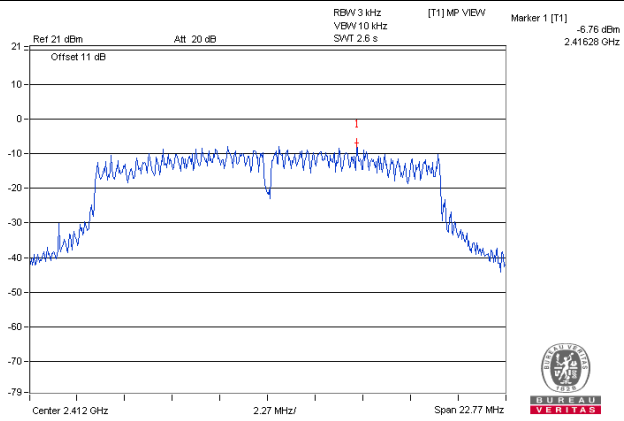

4.6 Conducted Out of Band Emission Measurement

4.6.1 Limits of Conducted Out of Band Emission Measurement

Below 20dB of the highest emission level of operating band (in 100kHz Resolution Bandwidth).

4.6.2 Test Setup

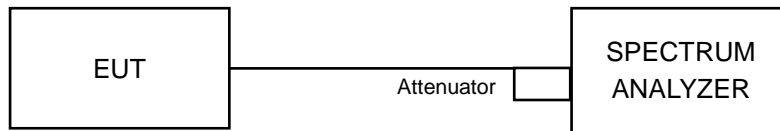

4.6.3 Test Instruments

Refer to section 4.1.2 to get information of above instrument.

4.6.4 Test Procedure

MEASUREMENT PROCEDURE REF

1. Set the RBW = 100 kHz.
2. Set the VBW \geq 300 kHz.
3. Detector = peak.
4. Sweep time = auto couple.
5. Trace mode = max hold.
6. Allow trace to fully stabilize.
7. Use the peak marker function to determine the maximum power level in any 100 kHz band segment within the fundamental EBW.

MEASUREMENT PROCEDURE OOB

1. Set RBW = 100 kHz.
2. Set VBW \geq 300 kHz.
3. Detector = peak.
4. Sweep = auto couple.
5. Trace Mode = max hold.
6. Allow trace to fully stabilize.
7. Use the peak marker function to determine the maximum amplitude level.

4.6.5 Deviation from Test Standard

No deviation.

4.6.6 EUT Operating Condition

Same as Item 4.3.6

4.6.7 Test Results

The spectrum plots are attached on the following pages. D1 line indicates the highest level, and D2 line indicates the 20dB offset below D1. It shows compliance with the requirement.

802.11b

CH 1

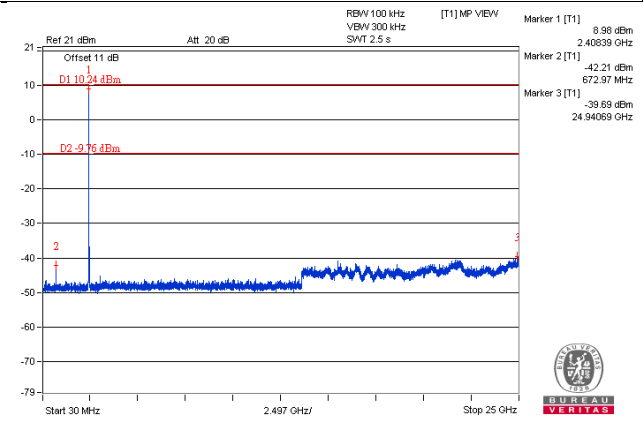
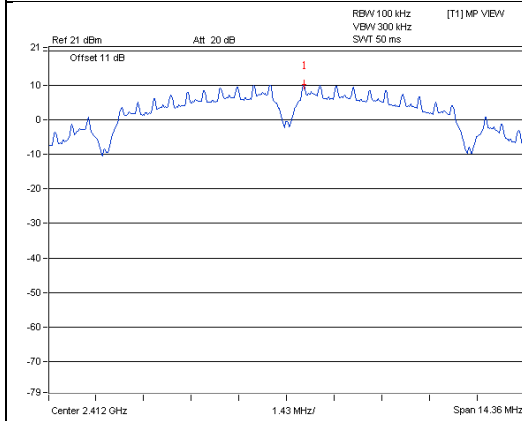

CH 6

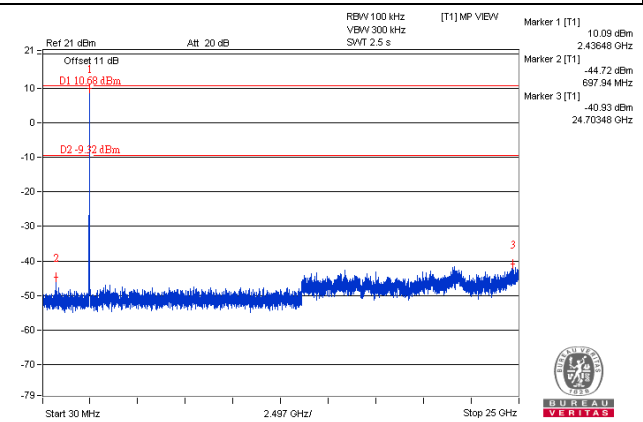
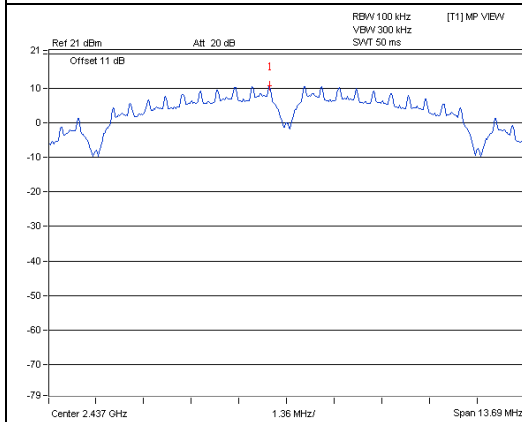

CH 11

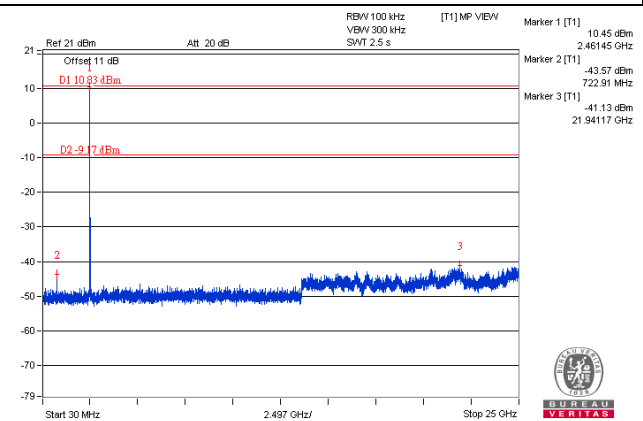
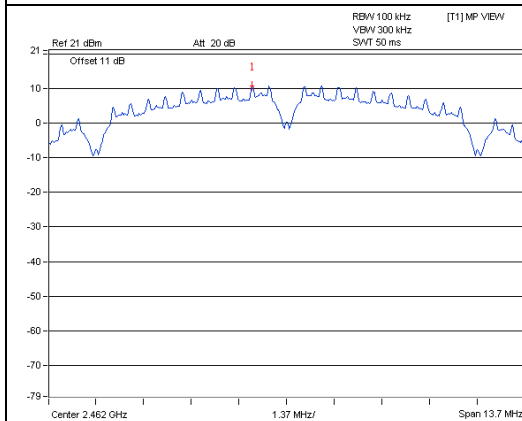

CH 1 Band edge

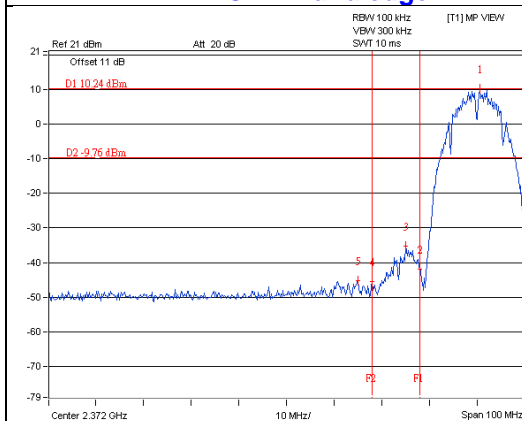

CH 11 Band edge

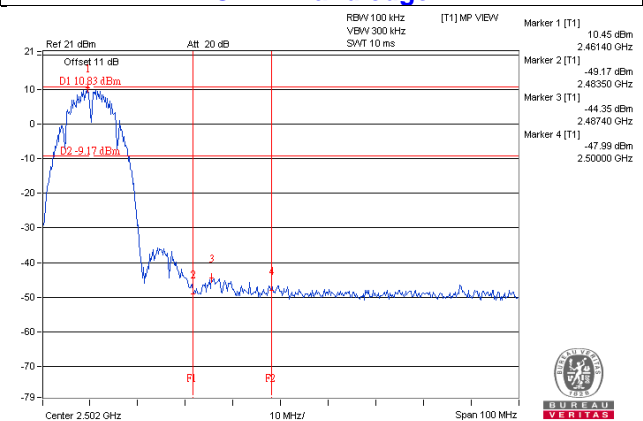

802.11g

CH 1

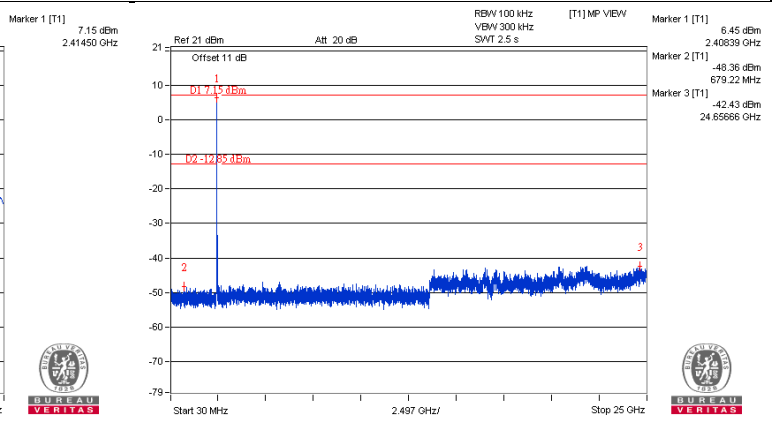
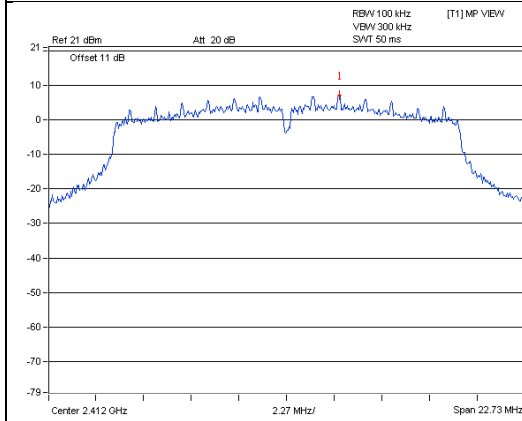

CH 6

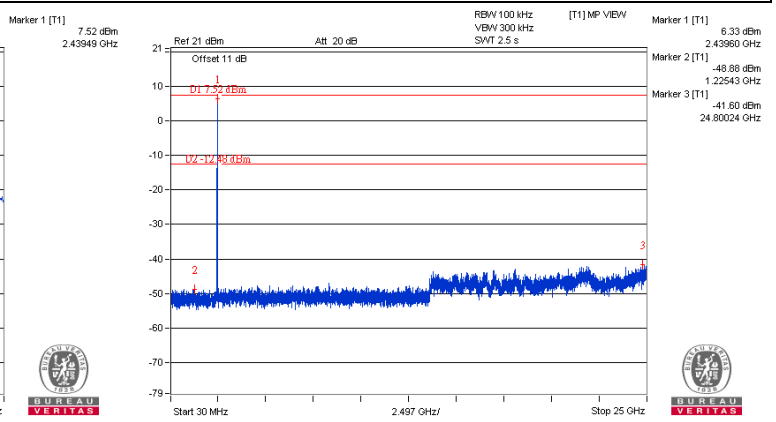
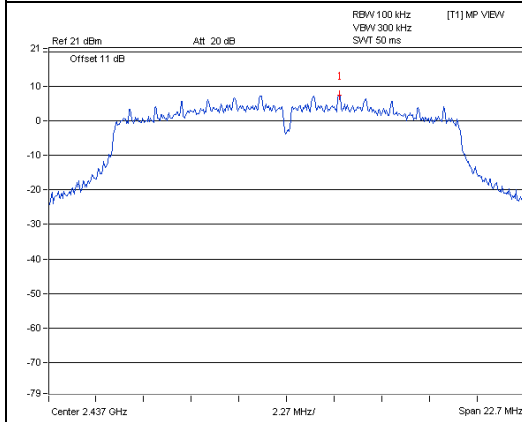

CH 11

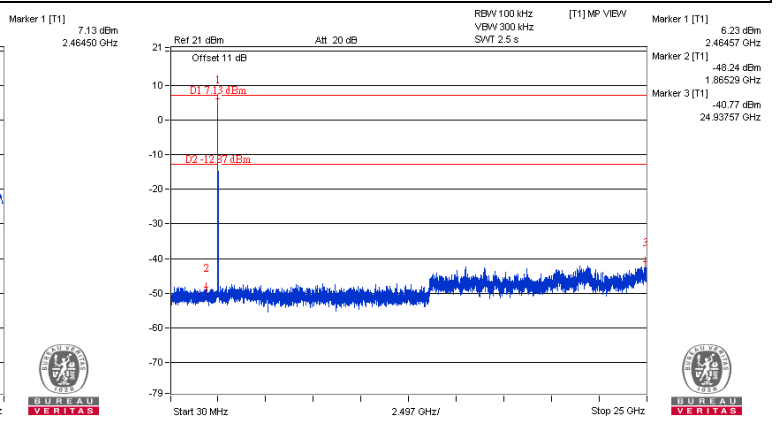
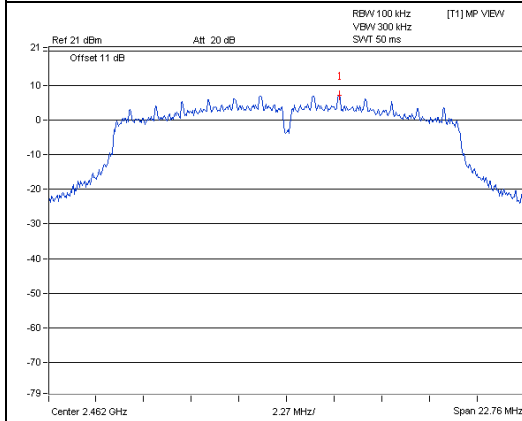

CH 1 Band edge

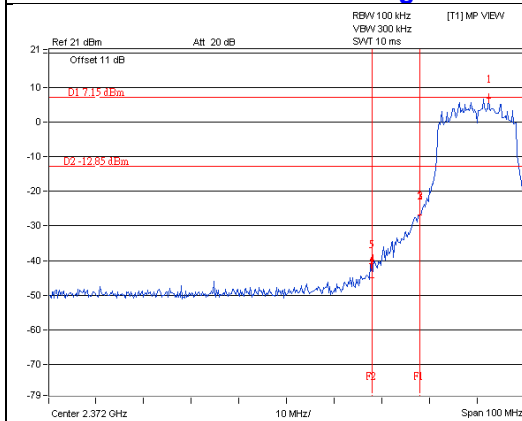

CH 11 Band edge

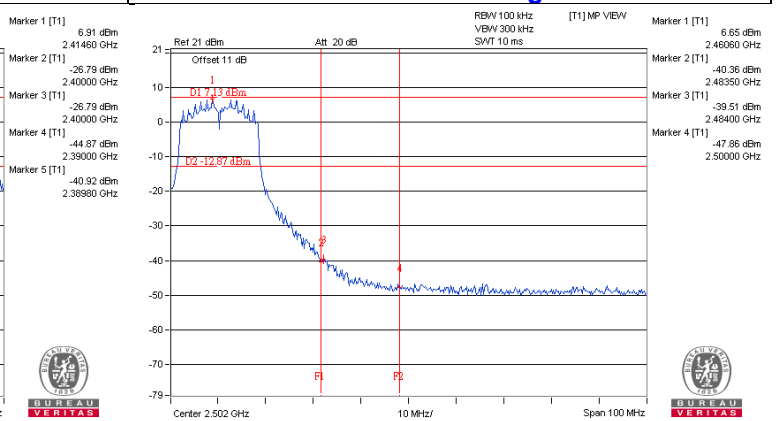

802.11n (HT20)

CH 1

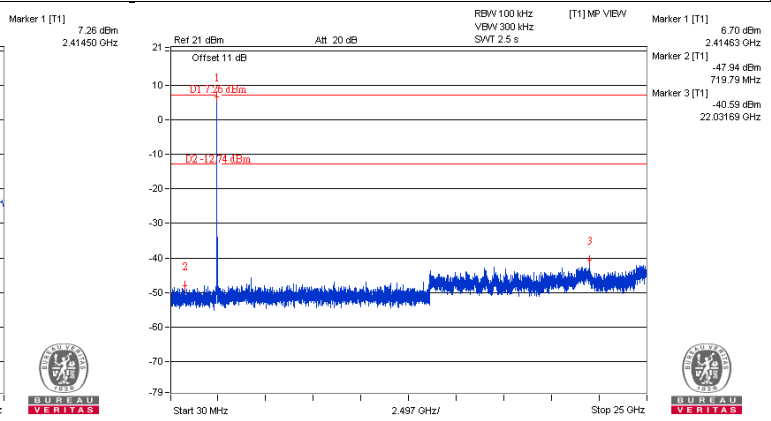
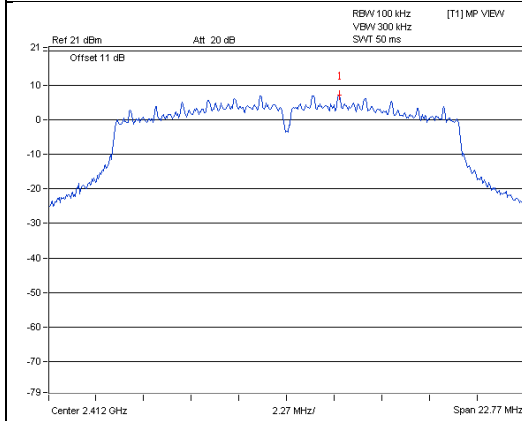

CH 6

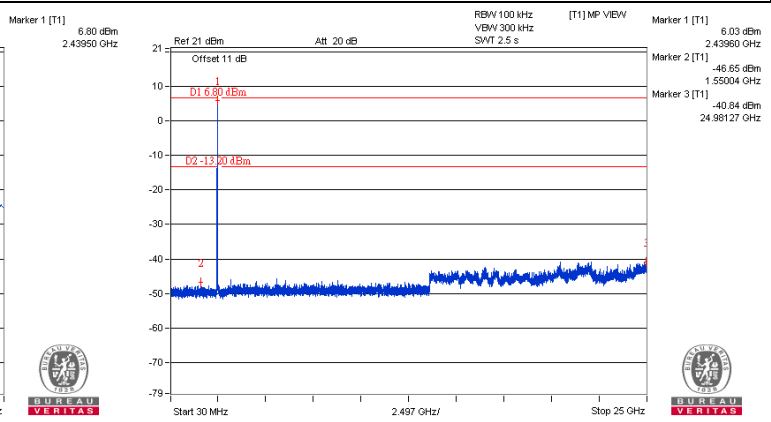
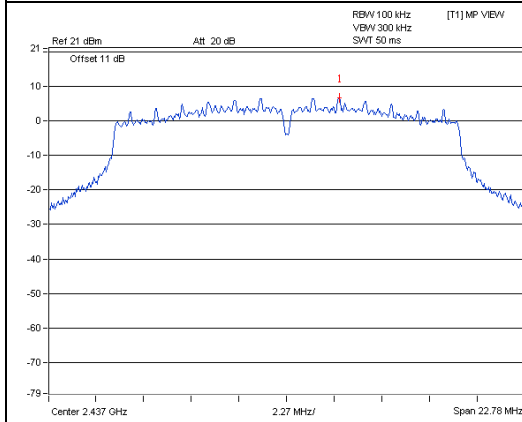

CH 11

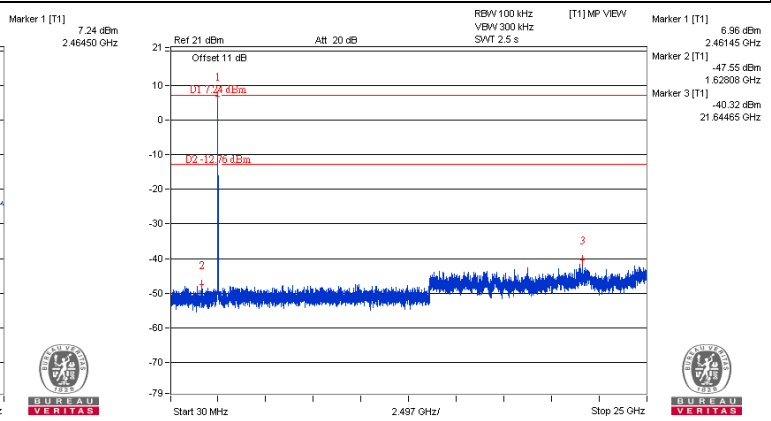
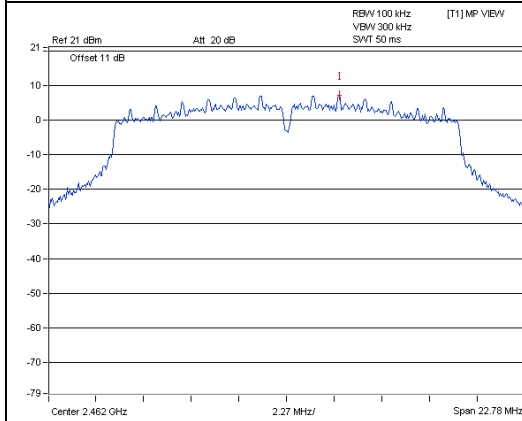

CH 1 Band edge

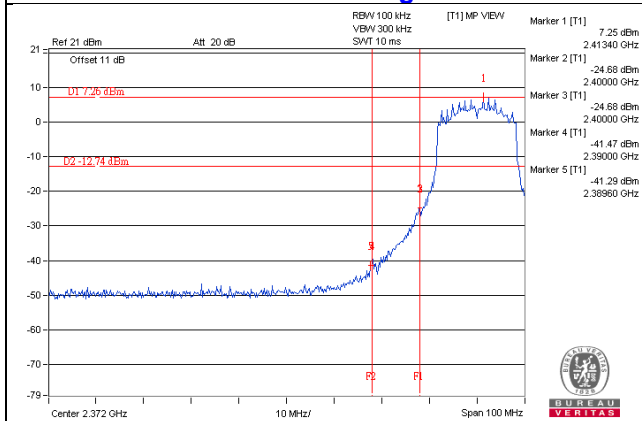

CH 11 Band edge

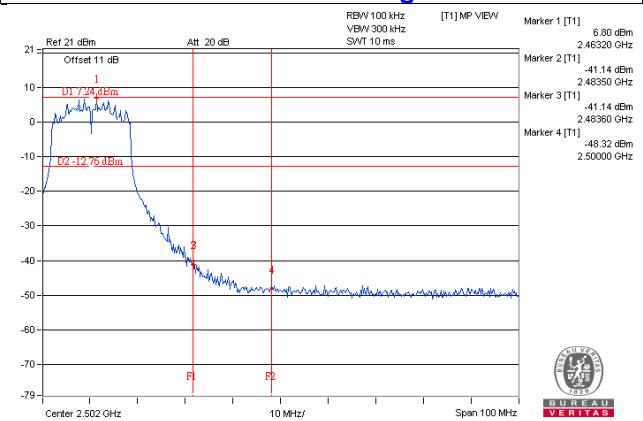



5 Pictures of Test Arrangements

Please refer to the attached file (Test Setup Photo).



Appendix – Information on the Testing Laboratories

We, Bureau Veritas Consumer Products Services (H.K.) Ltd., Taoyuan Branch, were founded in 1988 to provide our best service in EMC, Radio, Telecom and Safety consultation. Our laboratories are accredited and approved according to ISO/IEC 17025.

If you have any comments, please feel free to contact us at the following:

Linko EMC/RF Lab

Tel: 886-2-26052180

Fax: 886-2-26051924

Hsin Chu EMC/RF/Telecom Lab

Tel: 886-3-6668565

Fax: 886-3-6668323

Hwa Ya EMC/RF/Safety Lab

Tel: 886-3-3183232

Fax: 886-3-3270892

Email: service.adt@tw.bureauveritas.com

Web Site: www.bureauveritas-adt.com

The address and road map of all our labs can be found in our web site also.

--- END ---