

# FCC RF Test Report

APPLICANT : ATrack Technology Inc.  
EQUIPMENT : CDMA OBD Vehicle Tracker  
BRAND NAME : ATrack  
MODEL NAME : AX7  
FCC ID : YA7-ATVT1302  
STANDARD : FCC 47 CFR Part 2, 22(H), 24(E)  
CLASSIFICATION : PCS Licensed Transmitter (PCB)

The product was received on Apr. 30, 2013 and completely tested on May 24, 2013. We, SPORTON INTERNATIONAL INC., would like to declare that the tested sample has been evaluated in accordance with the procedures given in ANSI / TIA / EIA-603-C-2004 and shown compliance with the applicable technical standards.

The test results in this report apply exclusively to the tested model / sample. Without written approval of SPORTON INTERNATIONAL INC., the test report shall not be reproduced except in full.



Reviewed by: Joseph Lin / Supervisor



Approved by: Jones Tsai / Manager



## SPORTON INTERNATIONAL INC.

No. 52, Hwa Ya 1<sup>st</sup> Rd., Hwa Ya Technology Park, Kwei-Shan Hsiang, Tao Yuan Hsien, Taiwan, R.O.C.



# TABLE OF CONTENTS

**REVISION HISTORY..... 3**

**SUMMARY OF TEST RESULT ..... 4**

**1 GENERAL DESCRIPTION ..... 5**

    1.1 Applicant..... 5

    1.2 Manufacturer ..... 5

    1.3 Feature of Equipment Under Test..... 5

    1.4 Product Specification of Equipment Under Test ..... 5

    1.5 Maximum ERP/EIRP Power, Frequency Tolerance, and Emission Designator ..... 6

    1.6 Testing Site..... 6

    1.7 Applied Standards ..... 6

**2 TEST CONFIGURATION OF EQUIPMENT UNDER TEST ..... 7**

    2.1 Test Mode..... 7

    2.2 Connection Diagram of Test System ..... 8

    2.3 Support Unit used in test configuration and system ..... 8

    2.4 Measurement Results Explanation Example ..... 9

**3 TEST RESULT ..... 10**

    3.1 Conducted Output Power and ERP/EIRP Measurement ..... 10

    3.2 Peak-to-Average Ratio ..... 12

    3.3 99% Occupied Bandwidth and 26dB Bandwidth Measurement..... 18

    3.4 Band Edge Measurement..... 26

    3.5 Conducted Spurious Emission Measurement ..... 31

    3.6 Field Strength of Spurious Radiation Measurement ..... 37

    3.7 Frequency Stability Measurement..... 48

**4 LIST OF MEASURING EQUIPMENT ..... 51**

**5 UNCERTAINTY OF EVALUATION ..... 52**

**APPENDIX A. PHOTOGRAPHS OF EUT**

**APPENDIX B. SETUP PHOTOGRAPHS**



### REVISION HISTORY

| REPORT NO.  | VERSION | DESCRIPTION             | ISSUED DATE  |
|-------------|---------|-------------------------|--------------|
| FG343003-01 | Rev. 01 | Initial issue of report | May 30, 2013 |
|             |         |                         |              |
|             |         |                         |              |
|             |         |                         |              |
|             |         |                         |              |
|             |         |                         |              |
|             |         |                         |              |
|             |         |                         |              |
|             |         |                         |              |
|             |         |                         |              |
|             |         |                         |              |
|             |         |                         |              |
|             |         |                         |              |
|             |         |                         |              |
|             |         |                         |              |
|             |         |                         |              |
|             |         |                         |              |
|             |         |                         |              |
|             |         |                         |              |
|             |         |                         |              |



## SUMMARY OF TEST RESULT

| Report Section | FCC Rule                            | IC Rule                          | Description                                   | Limit                               | Result | Remark                                     |
|----------------|-------------------------------------|----------------------------------|-----------------------------------------------|-------------------------------------|--------|--------------------------------------------|
| 3.1            | §2.1046                             | RSS-132 (5.4)<br>RSS-133 (6.4)   | Conducted Output Power                        | N/A                                 | PASS   | -                                          |
| 3.1            | §22.913(a)(2)                       | RSS-132(5.4)<br>SRSP-503(5.1.3)  | Effective Radiated Power                      | < 7 Watts                           | PASS   | -                                          |
| 3.1            | §24.232(c)                          | RSS-133 (6.4)<br>SRSP-510(5.1.2) | Equivalent Isotropic Radiated Power           | < 2 Watts                           | PASS   | -                                          |
| 3.2            | §24.232(d)                          | RSS-132 (5.4)<br>RSS-133(6.4)    | Peak-to-Average Ratio                         | < 13 dB                             | PASS   | -                                          |
| 3.3            | §2.1049<br>§22.917(a)<br>§24.238(a) | RSS-GEN(4.6.1)<br>RSS-133(2.3)   | Occupied Bandwidth                            | N/A                                 | PASS   | -                                          |
| 3.4            | §2.1051<br>§22.917(a)<br>§24.238(a) | RSS-132 (5.5)<br>RSS-133 (6.5)   | Band Edge Measurement                         | < 43+10log <sub>10</sub> (P[Watts]) | PASS   | -                                          |
| 3.5            | §2.1051<br>§22.917(a)<br>§24.238(a) | RSS-132 (5.5)<br>RSS-133 (6.5)   | Conducted Spurious Emission                   | < 43+10log <sub>10</sub> (P[Watts]) | PASS   | -                                          |
| 3.6            | §2.1053<br>§22.917(a)<br>§24.238(a) | RSS-132 (5.5)<br>RSS-133 (6.5)   | Field Strength of Spurious Radiation          | < 43+10log <sub>10</sub> (P[Watts]) | PASS   | Under limit<br>11.88 dB at<br>1672.000 MHz |
| 3.7            | §2.1055<br>§22.355<br>§24.235       | RSS-132(5.3)<br>RSS-133(6.3)     | Frequency Stability for Temperature & Voltage | < 2.5 ppm                           | PASS   | -                                          |

# 1 General Description

## 1.1 Applicant

ATrack Technology Inc.

3F., No. 88, Sec. 1, Neihu Rd., Neihu Dist., Taipei City 11493 Taiwan (R.O.C.)

## 1.2 Manufacturer

ATrack Technology Inc.

3F., No. 88, Sec. 1, Neihu Rd., Neihu Dist., Taipei City 11493 Taiwan (R.O.C.)

## 1.3 Feature of Equipment Under Test

| Product Feature                 |                          |
|---------------------------------|--------------------------|
| Equipment                       | CDMA OBD Vehicle Tracker |
| Brand Name                      | ATrack                   |
| Model Name                      | AX7                      |
| FCC ID                          | YA7-ATVT1302             |
| EUT supports Radios application | CDMA                     |
| EUT Stage                       | Identical Prototype      |

Remark: The above EUT's information was declared by manufacturer. Please refer to the specifications or user's manual for more detailed description.

## 1.4 Product Specification of Equipment Under Test

| Product Specification subjective to this standard |                                                                                  |
|---------------------------------------------------|----------------------------------------------------------------------------------|
| Tx Frequency                                      | CDMA2000 BC0: 824.70 MHz ~ 848.31 MHz<br>CDMA2000 BC1: 1851.25 MHz ~ 1908.75 MHz |
| Rx Frequency                                      | CDMA2000 BC0: 869.70 MHz ~ 893.31 MHz<br>CDMA2000 BC1: 1931.25 MHz ~ 1988.75 MHz |
| Maximum Output Power to Antenna                   | CDMA2000 BC0 : 24.06 dBm<br>CDMA2000 BC1 : 24.17 dBm                             |
| Antenna Type                                      | Monopole Antenna                                                                 |
| Antenna Gain                                      | 0.00 dBi                                                                         |
| Type of Modulation                                | QPSK                                                                             |

### 1.5 Maximum ERP/EIRP Power, Frequency Tolerance, and Emission Designator

| FCC Rule | System             | Type of Modulation | Maximum ERP/EIRP (W) | Frequency Tolerance (% , Hz, ppm) | Emission Designator |
|----------|--------------------|--------------------|----------------------|-----------------------------------|---------------------|
| Part 22  | CDMA2000 BC0 1xRTT | QPSK               | 0.1552               | 0.04 ppm                          | 1M28F9W             |
| Part 24  | CDMA2000 BC1 1xRTT | QPSK               | 0.2612               | 0.03 ppm                          | 1M30F9W             |

### 1.6 Testing Site

|                           |                                                                                                                                                                 |           |                                |
|---------------------------|-----------------------------------------------------------------------------------------------------------------------------------------------------------------|-----------|--------------------------------|
| <b>Test Site</b>          | SPORTON INTERNATIONAL INC.                                                                                                                                      |           |                                |
| <b>Test Site Location</b> | No. 52, Hwa Ya 1 <sup>st</sup> Rd., Hwa Ya Technology Park,<br>Kwei-Shan Hsiang, Tao Yuan Hsien, Taiwan, R.O.C.<br>TEL: +886-3-327-3456<br>FAX: +886-3-328-4978 |           |                                |
| <b>Test Site No.</b>      | <b>Sporton Site No.</b>                                                                                                                                         |           | <b>FCC/IC Registration No.</b> |
|                           | TH02-HY                                                                                                                                                         | 03CH07-HY | 722060/4086B-1                 |

### 1.7 Applied Standards

According to the specifications of the manufacturer, the EUT must comply with the requirements of the following standards:

- ♦ FCC 47 CFR Part 2, 22(H), 24(E)
- ♦ FCC KDB 412172 D01 Determining ERP and ERIP v01

**Remark:**

1. All test items were verified and recorded according to the standards and without any deviation during the test.
2. This EUT has also been tested and complied with the requirements of FCC Part 15, Subpart B, recorded in a separate test report.

## 2 Test Configuration of Equipment Under Test

### 2.1 Test Mode

During all testing, EUT is in link mode with base station emulator at maximum power level. The spurious emission measurements were carried out in semi-anechoic chamber with 3-meter test range.

Frequency range investigated for radiated emission is as follows:

1. 30 MHz to 9000 MHz for CDMA2000 BC0.
2. 30 MHz to 19000 MHz for CDMA2000 BC1.

| Test Modes   |                                                                                                                  |                                                                     |
|--------------|------------------------------------------------------------------------------------------------------------------|---------------------------------------------------------------------|
| Band         | Radiated TCs                                                                                                     | Conducted TCs                                                       |
| CDMA2000 BC0 | <ul style="list-style-type: none"> <li>■ 1xRTT Link Mode + DC 12V</li> <li>■ 1xRTT Link Mode + DC 24V</li> </ul> | <ul style="list-style-type: none"> <li>■ 1xRTT Link Mode</li> </ul> |
| CDMA2000 BC1 | <ul style="list-style-type: none"> <li>■ 1xRTT Link Mode + DC 12V</li> <li>■ 1xRTT Link Mode + DC 24V</li> </ul> | <ul style="list-style-type: none"> <li>■ 1xRTT Link Mode</li> </ul> |

**Note:** The maximum RF output power levels are 1xRTT RC1+SO55 mode for CDMA2000 BC0 and CDMA2000 BC1 on QPSK Link; only these modes were used for all tests.

The conducted power table is as follows:

| Conducted Power (*Unit: dBm) |              |        |        |              |       |         |
|------------------------------|--------------|--------|--------|--------------|-------|---------|
| Band                         | CDMA2000 BC0 |        |        | CDMA2000 BC1 |       |         |
| Channel                      | 1013         | 384    | 777    | 25           | 600   | 1175    |
| Frequency                    | 824.7        | 836.52 | 848.31 | 1851.25      | 1880  | 1908.75 |
| 1xRTT RC1+SO55               | 23.90        | 24.06  | 23.35  | 23.09        | 24.17 | 23.26   |
| 1xRTT RC3+SO55               | 23.85        | 24.04  | 23.27  | 23.17        | 24.16 | 23.04   |
| 1xRTT RC3 SO32(+ F-SCH)      | 23.83        | 24.01  | 23.33  | 23.06        | 24.11 | 23.03   |
| 1xRTT RC3 SO32(+SCH)         | 23.87        | 24.05  | 23.31  | 23.12        | 24.14 | 23.12   |

## 2.2 Connection Diagram of Test System

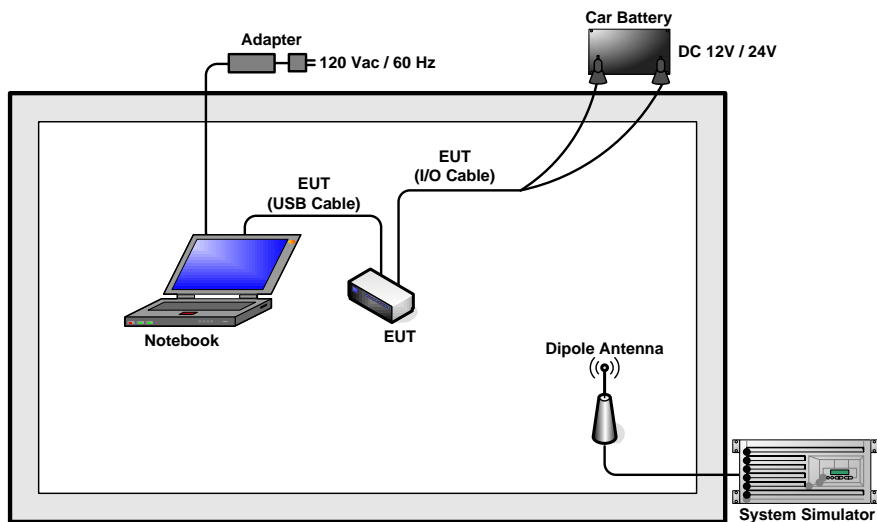

## 2.3 Support Unit used in test configuration and system

| Item | Equipment        | Trade Name | Model No. | FCC ID  | Data Cable | Power Cord                                                 |
|------|------------------|------------|-----------|---------|------------|------------------------------------------------------------|
| 1.   | System Simulator | R&S        | CMU 200   | N/A     | N/A        | Unshielded, 1.8 m                                          |
| 2.   | Notebook         | Lenovo     | TP00034A  | FCC DoC | N/A        | AC I/P:<br>Unshielded, 1.2 m<br>DC O/P:<br>Shielded, 1.8 m |
| 3.   | Car Battery      | YUASA      | 55B24R(S) | N/A     | N/A        | N/A                                                        |





## **2.4 Measurement Results Explanation Example**

**For all conducted test items:**

The offset level is set in the spectrum analyzer to compensate the RF cable loss and attenuator factor between EUT conducted output port and spectrum analyzer. With the offset compensation, the spectrum analyzer reading level is exactly the EUT RF output level.

The spectrum analyzer offset is derived from RF cable loss and attenuator factor.

*Offset = RF cable loss + attenuator factor.*

Following shows an offset computation example with cable loss 4.2 dB and 10dB attenuator.

Example :

$$\begin{aligned} \text{Offset(dB)} &= \text{RF cable loss(dB)} + \text{attenuator factor(dB)}. \\ &= 4.2 + 10 = 14.2 \text{ (dB)} \end{aligned}$$

### 3 Test Result

#### 3.1 Conducted Output Power and ERP/EIRP Measurement

##### 3.1.1 Description of the Conducted Output Power and ERP/EIRP Measurement

A base station simulator was used to establish communication with the EUT. Its parameters were set to transmit the maximum power on the EUT. The measured power in the radio frequency on the transmitter output terminals shall be reported.

The ERP of mobile transmitters must not exceed 7 Watts and the EIRP of mobile transmitters are limited to 2 Watts. According to KDB 412172 D01 Power Approach,

$EIRP = P_T + G_T - L_C$ ,  $ERP = EIRP - 2.15$ , where

$P_T$  = transmitter output power in dBm

$G_T$  = gain of the transmitting antenna in dBi

$L_C$  = signal attenuation in the connecting cable between the transmitter and antenna in dB

##### 3.1.2 Measuring Instruments

See list of measuring instruments of this test report.

##### 3.1.3 Test Procedures

1. The transmitter output port was connected to base station.
2. The RF output of EUT was connected to the spectrum analyzer by RF cable and attenuator. The path loss was compensated to the results for each measurement.
3. Set EUT at maximum power through base station.
4. Select lowest, middle, and highest channels for each band and different modulation.
5. Measure the maximum burst average power for GSM and maximum average power for other modulation signal.

##### 3.1.4 Test Setup

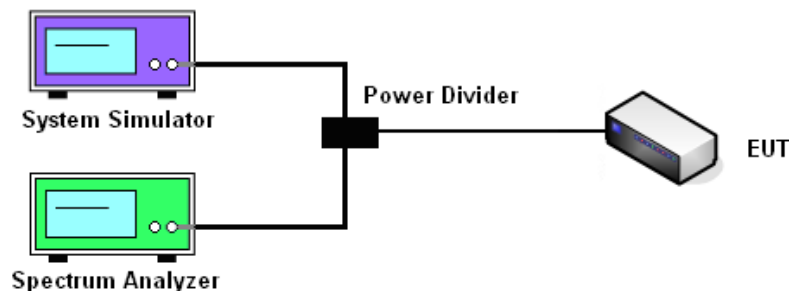

3.1.5 Test Result of Conducted Output Power

| Cellular Band ( $G_T - L_C = 0.00\text{dB}$ ) |                 |           |            |
|-----------------------------------------------|-----------------|-----------|------------|
| Modes                                         | CDMA 2000 1xRTT |           |            |
| Test Status                                   | RC1+SO55        |           |            |
| Channel                                       | 1013 (Low)      | 384 (Mid) | 777 (High) |
| Frequency (MHz)                               | 824.70          | 836.52    | 848.31     |
| Conducted Power (dBm)                         | 23.90           | 24.06     | 23.35      |
| Conducted Power (Watts)                       | 0.25            | 0.25      | 0.22       |
| ERP(dBm)                                      | 21.75           | 21.91     | 21.20      |
| ERP(Watts)                                    | 0.1496          | 0.1552    | 0.1318     |

| PCS Band ( $G_T - L_C = 0.00\text{dB}$ ) |                 |           |             |
|------------------------------------------|-----------------|-----------|-------------|
| Modes                                    | CDMA 2000 1xRTT |           |             |
| Test Status                              | RC1+SO55        |           |             |
| Channel                                  | 25 (Low)        | 600 (Mid) | 1175 (High) |
| Frequency (MHz)                          | 1851.25         | 1880.00   | 1908.75     |
| Conducted Power (dBm)                    | 23.09           | 24.17     | 23.26       |
| Conducted Power (Watts)                  | 0.20            | 0.26      | 0.21        |
| EIRP(dBm)                                | 23.09           | 24.17     | 23.26       |
| EIRP(Watts)                              | 0.2037          | 0.2612    | 0.2118      |

Note:

$EIRP = P_T + G_T - L_C$ ,  $ERP = EIRP - 2.15$ , where

$P_T$  = transmitter output power in dBm

$G_T$  = gain of the transmitting antenna in dBi

$L_C$  = signal attenuation in the connecting cable between the transmitter and antenna in dB

## 3.2 Peak-to-Average Ratio

### 3.2.1 Description of the PAR Measurement

The peak-to-average ratio (PAR) of the transmission may not exceed 13 dB.

### 3.2.2 Measuring Instruments

See list of measuring instruments of this test report.

### 3.2.3 Test Procedures

1. The EUT was connected to Spectrum Analyzer and System Simulator via power divider.
2. Set the CCDF (Complementary Cumulative Distribution Function) option in spectrum analyzer.
3. The highest RF powers were measured and recorded the maximum PAPR level associated with a probability of 0.1 %.
4. Record the deviation as Peak to Average Ratio.

### 3.2.4 Test Setup

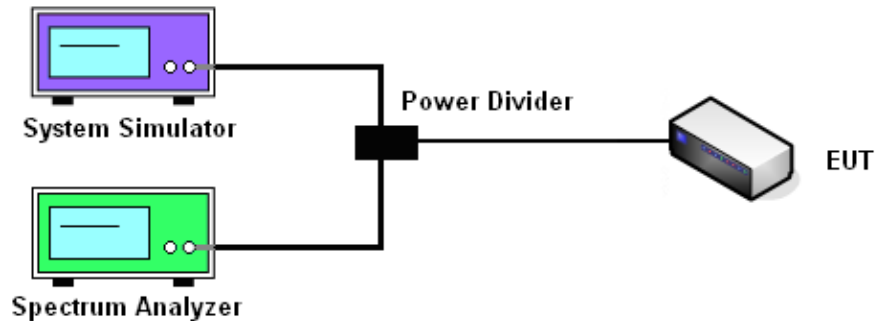

**3.2.5 Test Result of Peak-to-Average Ratio**

| CDMA2000 BC0               |                 |           |            |
|----------------------------|-----------------|-----------|------------|
| Modes                      | CDMA 2000 1xRTT |           |            |
| Test Status                | RC1+SO55        |           |            |
| Channel                    | 1013 (Low)      | 384 (Mid) | 777 (High) |
| Frequency (MHz)            | 824.70          | 836.52    | 848.31     |
| Peak-to-Average Ratio (dB) | 3.28            | 3.44      | 3.12       |

| CDMA2000 BC1               |                 |           |             |
|----------------------------|-----------------|-----------|-------------|
| Modes                      | CDMA 2000 1xRTT |           |             |
| Test Status                | RC1+SO55        |           |             |
| Channel                    | 25 (Low)        | 600 (Mid) | 1175 (High) |
| Frequency (MHz)            | 1851.25         | 1880.00   | 1908.75     |
| Peak-to-Average Ratio (dB) | 2.36            | 2.32      | 2.96        |

### 3.2.6 Test Result (Plots) of Peak-to-Average Ratio

|        |              |             |                       |
|--------|--------------|-------------|-----------------------|
| Band : | CDMA2000 BC0 | Test Mode : | 1xRTT_RC1+SO55 (QPSK) |
|--------|--------------|-------------|-----------------------|

#### Peak-to-Average Ratio on Channel 1013 (824.70 MHz)

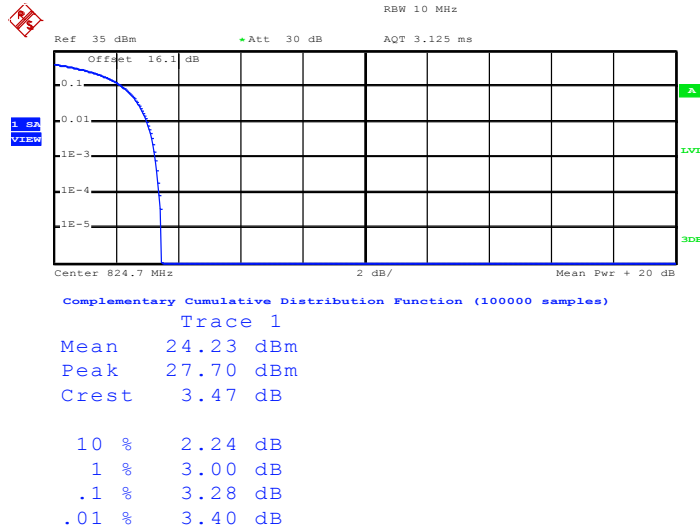

Date: 24.MAY.2013 13:56:46

#### Peak-to-Average Ratio on Channel 384 (836.52 MHz)

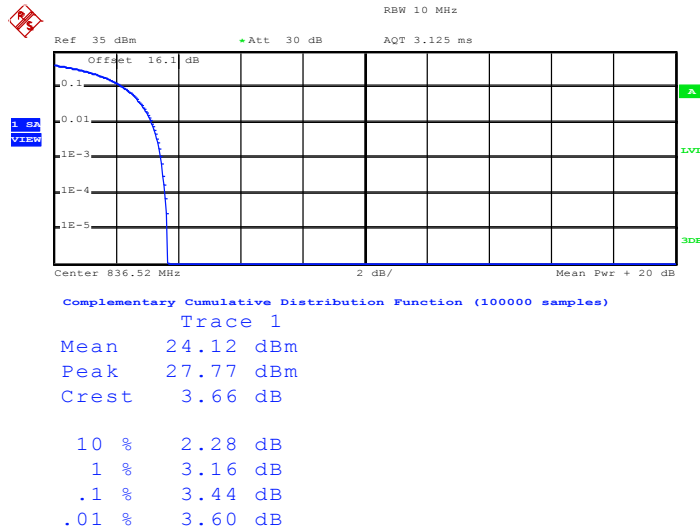

Date: 24.MAY.2013 13:56:09



Peak-to-Average Ratio on Channel 777 (848.31 MHz)

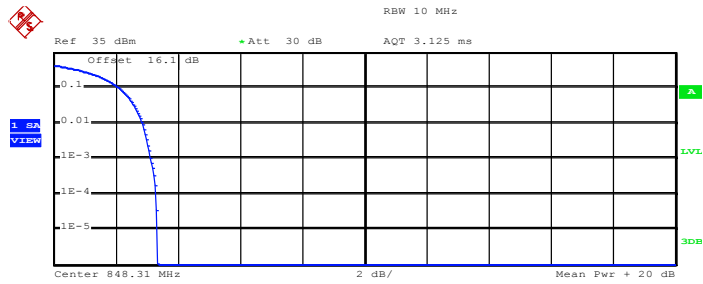

Complementary Cumulative Distribution Function (100000 samples)

Trace 1

Mean 23.96 dBm  
 Peak 27.28 dBm  
 Crest 3.32 dB

10 % 2.12 dB  
 1 % 2.88 dB  
 .1 % 3.12 dB  
 .01 % 3.32 dB

Date: 24.MAY.2013 13:55:23



|               |              |                    |                       |
|---------------|--------------|--------------------|-----------------------|
| <b>Band :</b> | CDMA2000 BC1 | <b>Test Mode :</b> | 1xRTT_RC1+SO55 (QPSK) |
|---------------|--------------|--------------------|-----------------------|

Peak-to-Average Ratio on Channel 25 (1851.25 MHz)

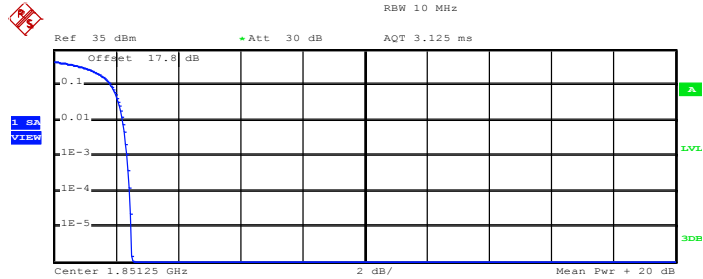

Complementary Cumulative Distribution Function (100000 samples)

Trace 1

|       |           |
|-------|-----------|
| Mean  | 23.63 dBm |
| Peak  | 26.15 dBm |
| Crest | 2.52 dB   |
| 10 %  | 1.84 dB   |
| 1 %   | 2.24 dB   |
| .1 %  | 2.36 dB   |
| .01 % | 2.44 dB   |

Date: 24.MAY.2013 15:04:30

Peak-to-Average Ratio on Channel 600 (1880 MHz)

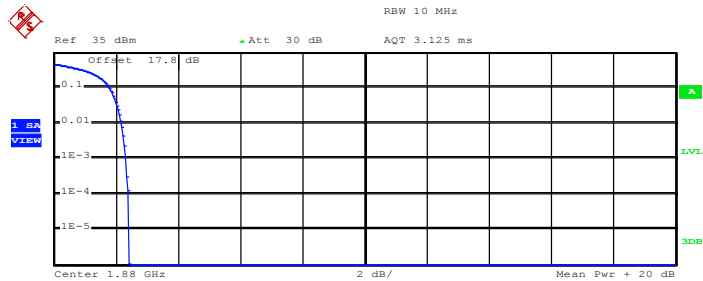

Complementary Cumulative Distribution Function (100000 samples)

Trace 1

|       |           |
|-------|-----------|
| Mean  | 24.36 dBm |
| Peak  | 26.79 dBm |
| Crest | 2.43 dB   |
| 10 %  | 1.80 dB   |
| 1 %   | 2.20 dB   |
| .1 %  | 2.32 dB   |
| .01 % | 2.40 dB   |

Date: 24.MAY.2013 15:05:36





Peak-to-Average Ratio on Channel 1175 (1908.75 MHz)

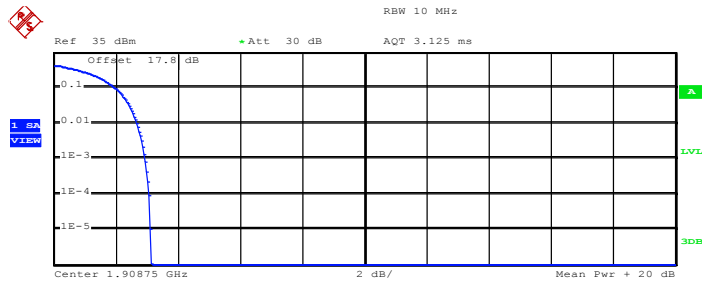

Complementary Cumulative Distribution Function (100000 samples)

Trace 1

|       |           |
|-------|-----------|
| Mean  | 23.39 dBm |
| Peak  | 26.50 dBm |
| Crest | 3.12 dB   |
| 10 %  | 2.00 dB   |
| 1 %   | 2.68 dB   |
| .1 %  | 2.96 dB   |
| .01 % | 3.08 dB   |

Date: 24.MAY.2013 15:06:40

### 3.3 99% Occupied Bandwidth and 26dB Bandwidth Measurement

#### 3.3.1 Description of 99% Occupied Bandwidth and 26dB Bandwidth Measurement

The 99% occupied bandwidth is the width of a frequency band such that, below the lower and above the upper frequency limits, the mean powers emitted are each equal to a specified percentage 0.5% of the total mean transmitted power.

The emission bandwidth is defined as the width of the signal between two points, located at the 2 sides of the carrier frequency, outside of which all emissions are attenuated at least 26 dB below the transmitter power.

#### 3.3.2 Measuring Instruments

See list of measuring instruments of this test report.

#### 3.3.3 Test Procedures

1. The EUT was connected to Spectrum Analyzer and Base Station via power divider.
2. The RF output of EUT was connected to the spectrum analyzer by RF cable and attenuator. The path loss was compensated to the results for each measurement.
3. The 99% occupied bandwidth were measured, set RBW= 1% of span, VBW= 3\*RBW, sample detector, trace maximum hold.
4. The 26dB bandwidth were measured, set RBW= 1% of EBW, VBW= 3\*RBW, peak detector, trace maximum hold.

#### 3.3.4 Test Setup

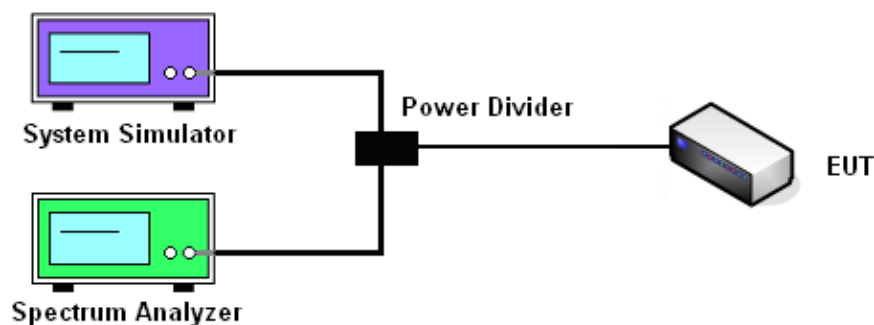



3.3.5 Test Result of Occupied Bandwidth and 26dB Bandwidth

| CDMA2000 BC0    |                 |           |            |
|-----------------|-----------------|-----------|------------|
| Test Mode       | CDMA 2000 1xRTT |           |            |
| Test Status     | RC1+SO55        |           |            |
| Channel         | 1013 (Low)      | 384 (Mid) | 777 (High) |
| Frequency (MHz) | 824.70          | 836.52    | 848.31     |
| 99% OBW (MHz)   | 1.280           | 1.276     | 1.280      |
| 26dB BW (MHz)   | 1.444           | 1.436     | 1.436      |

| CDMA2000 BC1    |                 |           |             |
|-----------------|-----------------|-----------|-------------|
| Test Mode       | CDMA 2000 1xRTT |           |             |
| Test Status     | RC1+SO55        |           |             |
| Channel         | 25 (Low)        | 600 (Mid) | 1175 (High) |
| Frequency (MHz) | 1851.25         | 1880.00   | 1908.75     |
| 99% OBW (MHz)   | 1.296           | 1.300     | 1.284       |
| 26dB BW (MHz)   | 1.484           | 1.548     | 1.448       |



3.3.6 Test Result (Plots) of Occupied Bandwidth and 26dB Bandwidth

|        |              |             |                       |
|--------|--------------|-------------|-----------------------|
| Band : | CDMA2000 BC0 | Test Mode : | 1xRTT_RC1+SO55 (QPSK) |
|--------|--------------|-------------|-----------------------|

99% Occupied Bandwidth Plot on Channel 1013 (824.7 MHz)

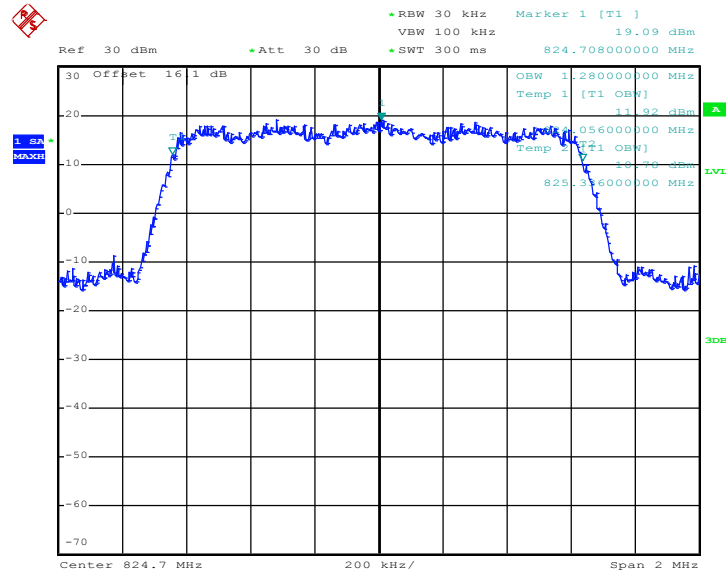

Date: 24.MAY.2013 14:28:47

26dB Bandwidth Plot on Channel 1013 (824.7 MHz)

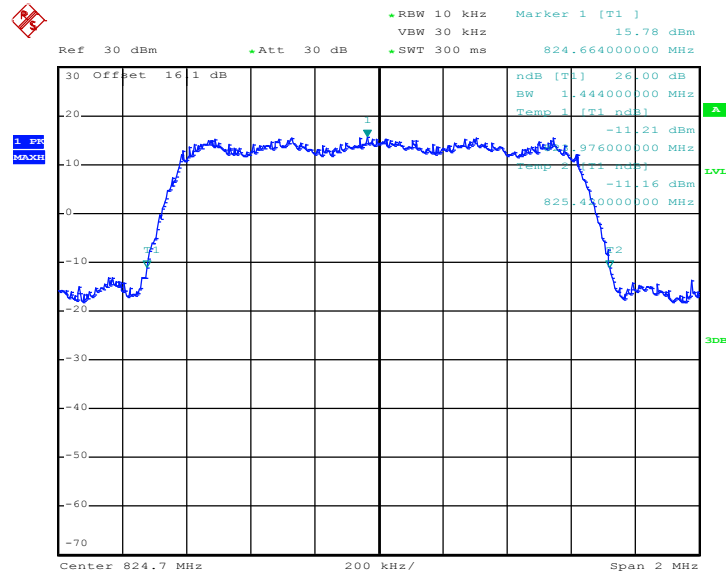

Date: 24.MAY.2013 14:19:47



99% Occupied Bandwidth Plot on Channel 384 (836.52 MHz)

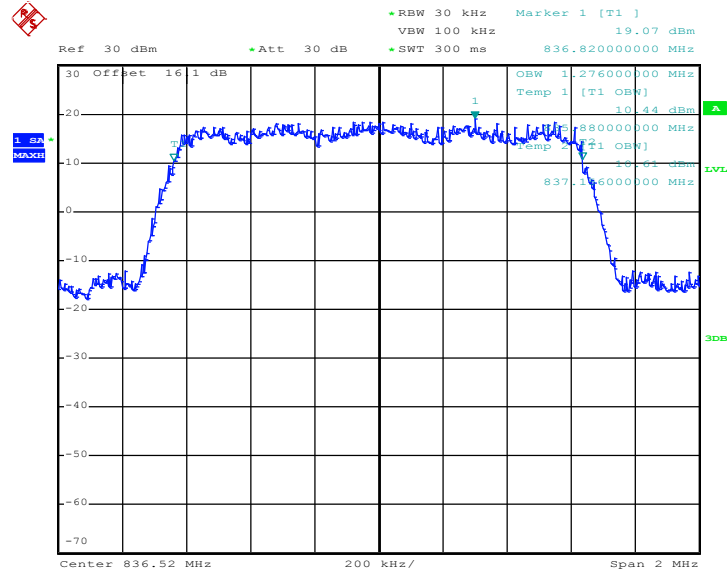

Date: 24.MAY.2013 14:26:23

26dB Bandwidth Plot on Channel 384 (836.52 MHz)

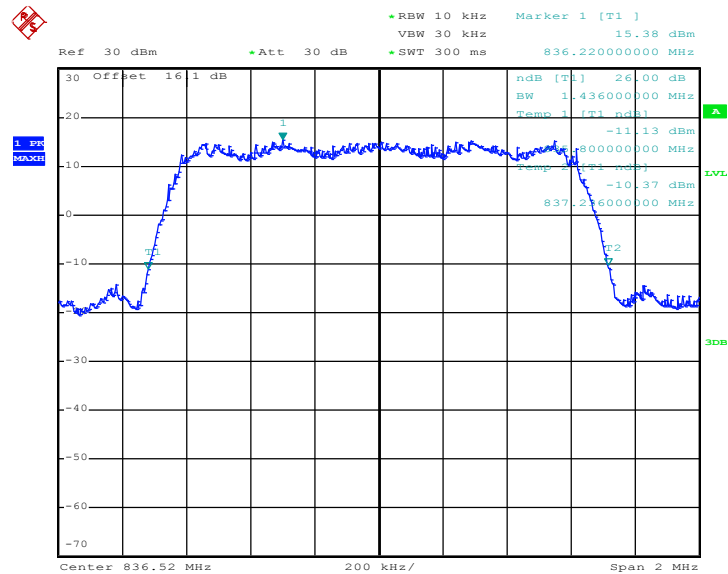

Date: 24.MAY.2013 14:21:08



### 99% Occupied Bandwidth Plot on Channel 777 (848.31 MHz)

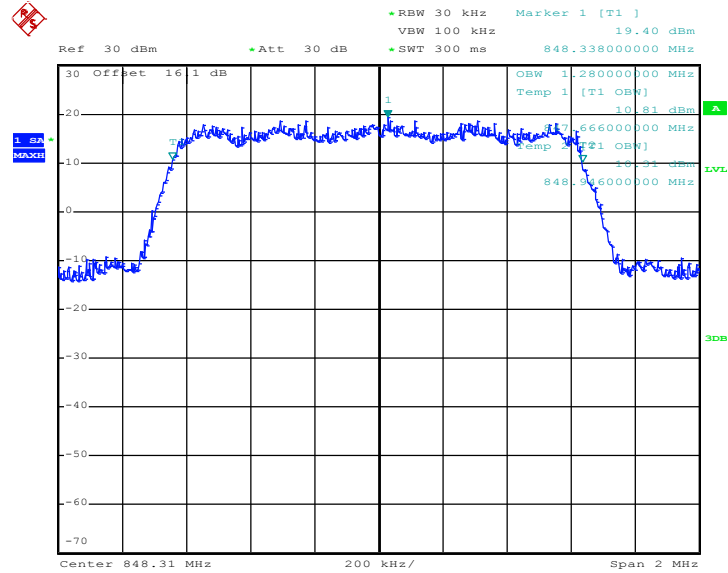

Date: 24.MAY.2013 14:24:41

### 26dB Bandwidth Plot on Channel 777 (848.31 MHz)

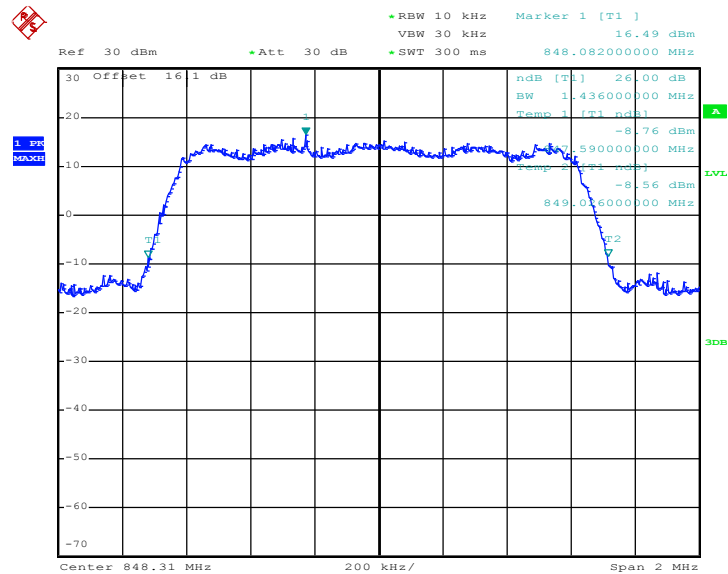

Date: 24.MAY.2013 14:22:33



|        |              |             |                       |
|--------|--------------|-------------|-----------------------|
| Band : | CDMA2000 BC1 | Test Mode : | 1xRTT_RC1+SO55 (QPSK) |
|--------|--------------|-------------|-----------------------|

99% Occupied Bandwidth Plot on Channel 25 (1851.25 MHz)

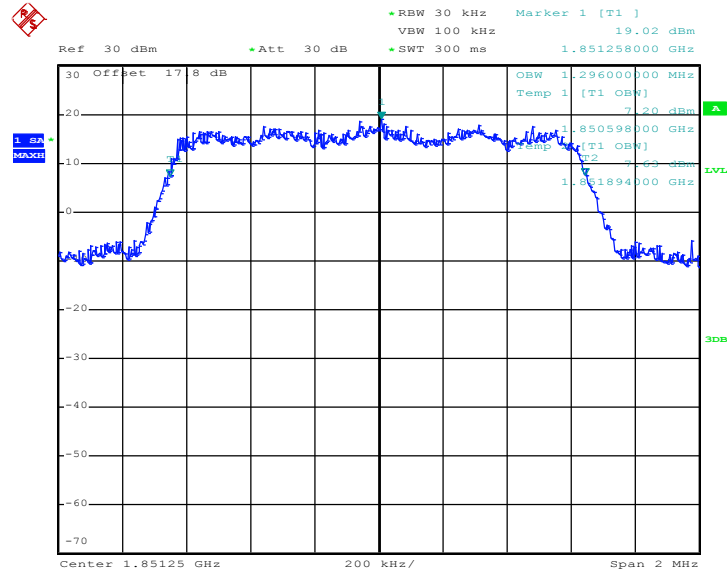

Date: 24.MAY.2013 15:26:30

26dB Bandwidth Plot on Channel 25 (1851.25 MHz)

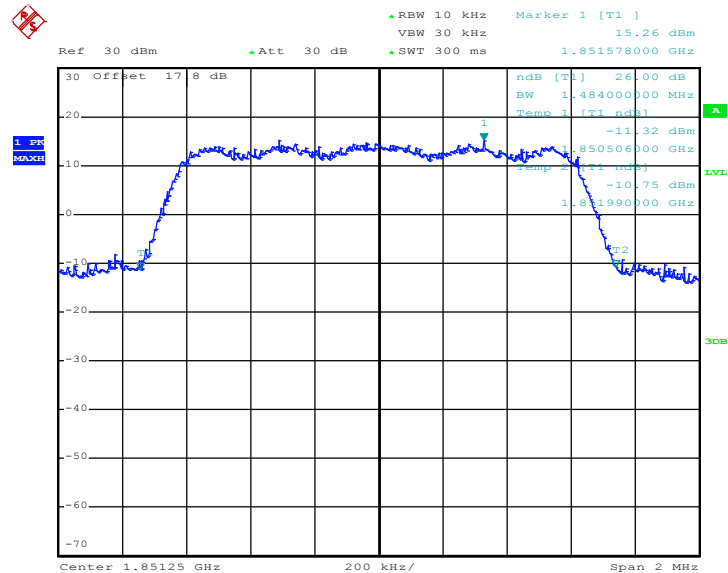

Date: 24.MAY.2013 15:11:12







99% Occupied Bandwidth Plot on Channel 1175 (1908.75 MHz)

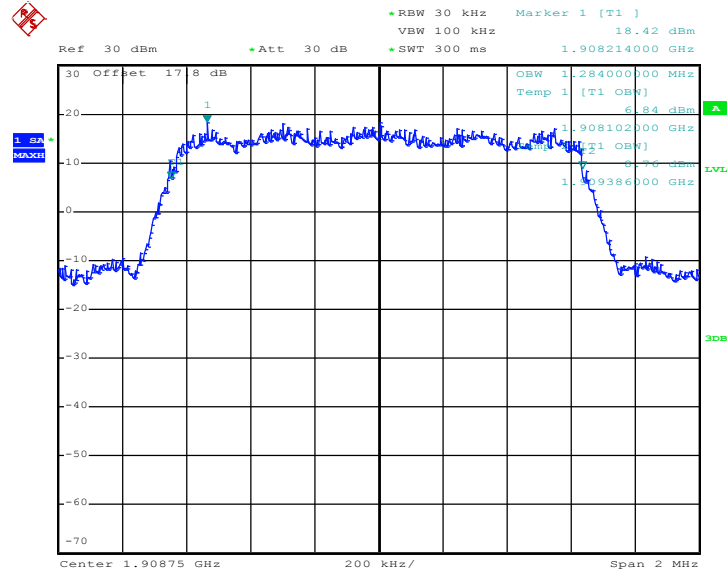

Date: 24.MAY.2013 15:16:07

26dB Bandwidth Plot on Channel 1175 (1908.75 MHz)

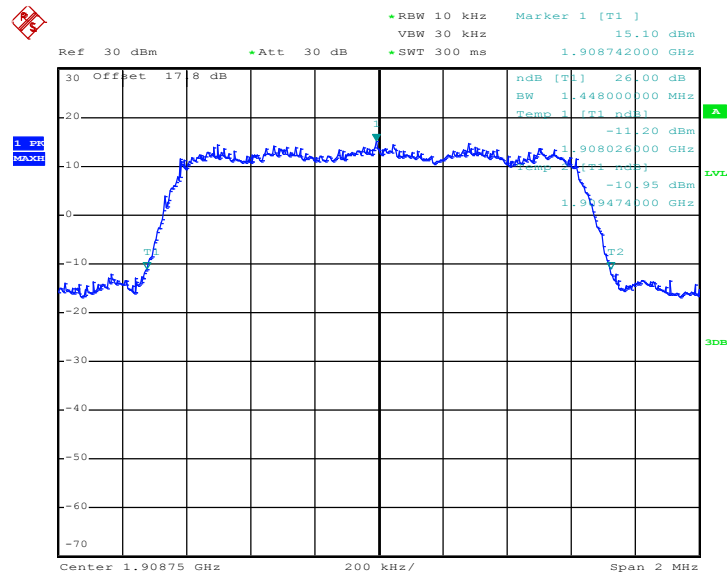

Date: 24.MAY.2013 15:14:09

### 3.4 Band Edge Measurement

#### 3.4.1 Description of Band Edge Measurement

The power of any emission outside of the authorized operating frequency ranges must be lower than the transmitter power (P) by a factor of at least  $43 + 10 \log (P)$  dB.

#### 3.4.2 Measuring Instruments

See list of measuring instruments of this test report.

#### 3.4.3 Test Procedures

1. The EUT was connected to Spectrum Analyzer and Base Station via power divider.
2. The RF output of EUT was connected to the spectrum analyzer by RF cable and attenuator. The path loss was compensated to the results for each measurement.
3. The band edges of low and high channels for the highest RF powers were measured. Setting RBW as roughly BW/100.
4. The RBW was replaced by 10 kHz, slightly smaller than the value in (3), due to the spectrum analyzer limitation to set the exact value. A worst case correction factor of  $10 \cdot \log (1\% \text{ emission-BW/measurement RBW})$  was compensated.
5. The RF fundamental frequency should be excluded against the limit line in the operating frequency band.
6. The limit line is derived from  $43 + 10\log(P)$  dB below the transmitter power P(Watts)
 
$$= P(W) - [43 + 10\log(P)] \text{ (dB)}$$

$$= [30 + 10\log(P)] \text{ (dBm)} - [43 + 10\log(P)] \text{ (dB)}$$

$$= -13\text{dBm}.$$

#### 3.4.4 Test Setup

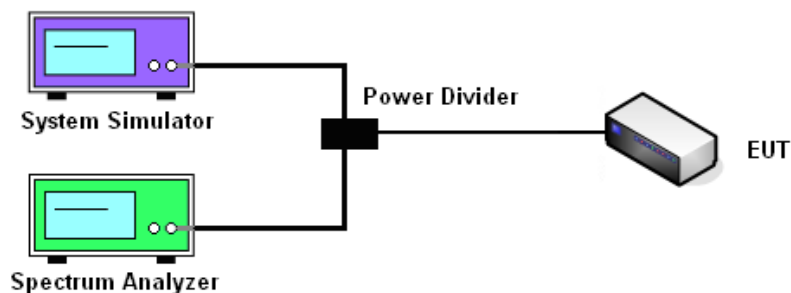



3.4.5 Test Result (Plots) of Conducted Band Edge

|                     |              |                          |                       |
|---------------------|--------------|--------------------------|-----------------------|
| Band :              | CDMA2000 BC0 | Test Mode :              | 1xRTT_RC1+SO55 (QPSK) |
| Correction Factor : | 1.60dB       | Maximum 26dB Bandwidth : | 1.444MHz              |
| Band Edge :         | -14.59dBm    | Measurement Value :      | -16.19dBm             |

Lower Band Edge Plot on Channel 1013 (824.7 MHz)

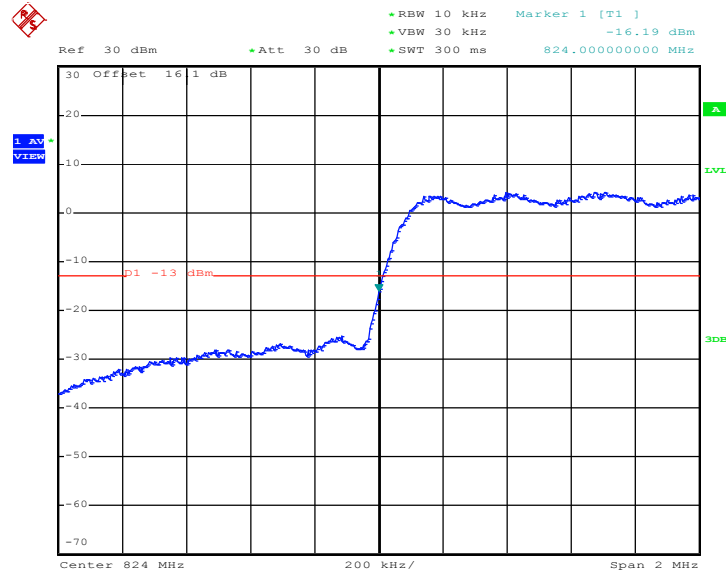

Date: 24.MAY.2013 14:32:49

1. Correction Factor(dB)= 10log(1% Emission BW/RBW)
  2. Band Edge= Measurement Value + Correction Factor(dB)
- For example, -16.19dBm + 1.60dB = -14.59dBm



|                            |              |                                |                       |
|----------------------------|--------------|--------------------------------|-----------------------|
| <b>Band :</b>              | CDMA2000 BC0 | <b>Test Mode :</b>             | 1xRTT_RC1+SO55 (QPSK) |
| <b>Correction Factor :</b> | 1.60dB       | <b>Maximum 26dB Bandwidth:</b> | 1.444MHz              |
| <b>Band Edge :</b>         | -13.03dBm    | <b>Measurement Value :</b>     | -14.63dBm             |

Higher Band Edge Plot on Channel 777 (848.31 MHz)

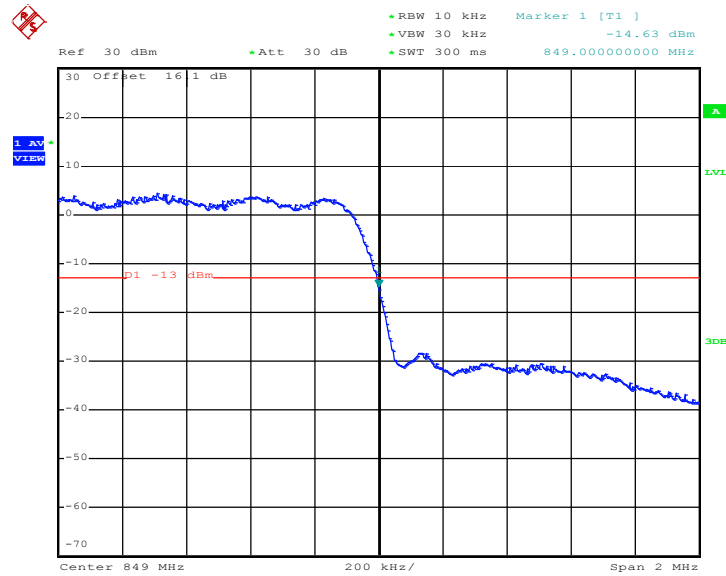

Date: 24.MAY.2013 14:45:12

1. Correction Factor(dB)= 10log(1% Emission BW/RBW)
2. Band Edge= Measurement Value + Correction Factor(dB)



|                            |              |                                |                       |
|----------------------------|--------------|--------------------------------|-----------------------|
| <b>Band :</b>              | CDMA2000 BC1 | <b>Test Mode :</b>             | 1xRTT_RC1+SO55 (QPSK) |
| <b>Correction Factor :</b> | 1.90dB       | <b>Maximum 26dB Bandwidth:</b> | 1.548MHz              |
| <b>Band Edge :</b>         | -22.71dBm    | <b>Measurement Value :</b>     | -24.61dBm             |

Lower Band Edge Plot on Channel 25 (1851.25 MHz)

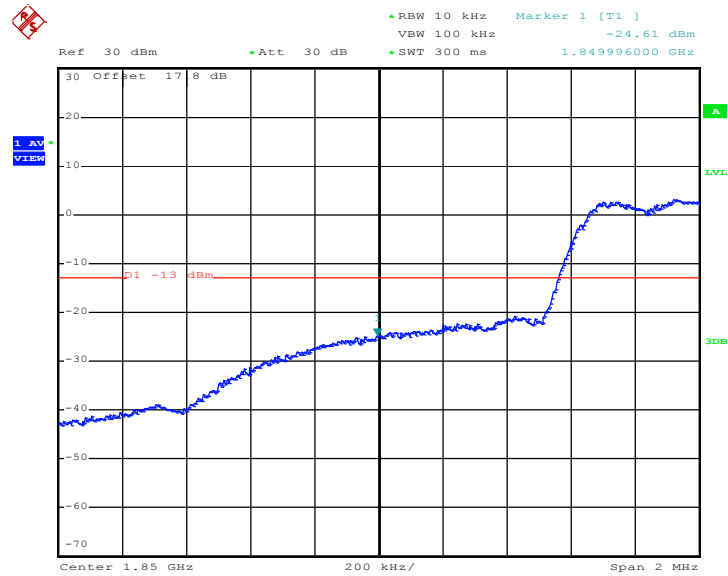

Date: 24.MAY.2013 15:29:33

1. Correction Factor(dB)= 10log(1% Emission BW/RBW)
2. Band Edge= Measurement Value + Correction Factor(dB)



|                     |              |                         |                       |
|---------------------|--------------|-------------------------|-----------------------|
| Band :              | CDMA2000 BC1 | Test Mode :             | 1xRTT_RC1+SO55 (QPSK) |
| Correction Factor : | 1.90dB       | Maximum 26dB Bandwidth: | 1.548MHz              |
| Band Edge :         | -26.98dBm    | Measurement Value :     | -28.88dBm             |

Higher Band Edge Plot on Channel 1175 (1908.75 MHz)

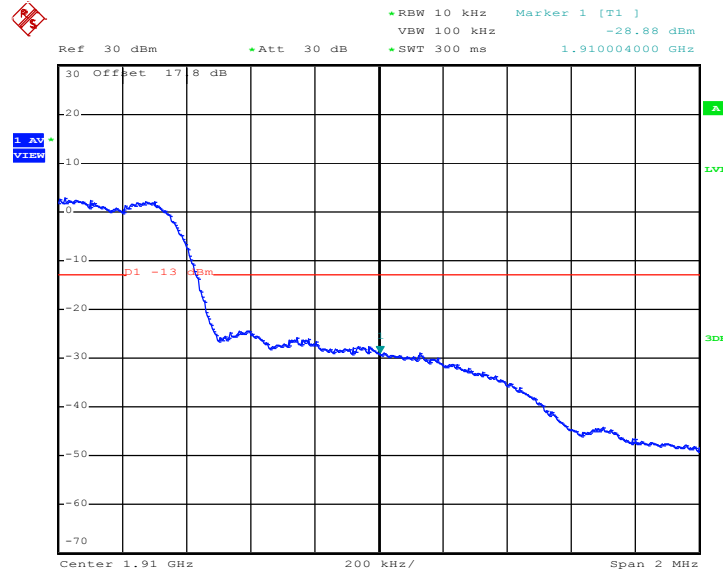

Date: 24.MAY.2013 15:30:52

1. Correction Factor(dB)=  $10\log(1\% \text{ Emission BW/RBW})$
2. Band Edge= Measurement Value + Correction Factor(dB)

### 3.5 Conducted Spurious Emission Measurement

#### 3.5.1 Description of Conducted Emission Measurement

The power of any emission outside of the authorized operating frequency ranges must be lower than the transmitter power (P) by a factor of at least  $43 + 10 \log (P)$  dB.

It is measured by means of a calibrated spectrum analyzer and scanned from 30 MHz up to a frequency including its 10<sup>th</sup> harmonic.

#### 3.5.2 Measuring Instruments

See list of measuring instruments of this test report.

#### 3.5.3 Test Procedures

1. The EUT was connected to spectrum analyzer and base station via power divider.
2. The RF output of EUT was connected to the spectrum analyzer by RF cable and attenuator. The path loss was compensated to the results for each measurement.
3. The middle channel for the highest RF power within the transmitting frequency was measured.
4. The conducted spurious emission for the whole frequency range was taken.
5. The RF fundamental frequency should be excluded against the limit line in the operating frequency band.
6. The limit line is derived from  $43 + 10\log(P)$  dB below the transmitter power P(Watts)
 
$$= P(W) - [43 + 10\log(P)] \text{ (dB)}$$

$$= [30 + 10\log(P)] \text{ (dBm)} - [43 + 10\log(P)] \text{ (dB)}$$

$$= -13\text{dBm}.$$

#### 3.5.4 Test Setup

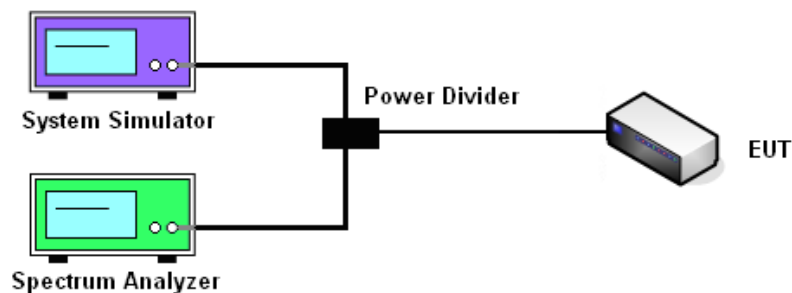

### 3.5.5 Test Result (Plots) of Conducted Spurious Emission

|             |                       |             |            |
|-------------|-----------------------|-------------|------------|
| Band :      | CDMA2000 BC0          | Channel     | 384        |
| Test Mode : | 1xRTT_RC1+SO55 (QPSK) | Frequency : | 836.52 MHz |

Conducted Spurious Emission Plot between 30MHz ~ 1GHz

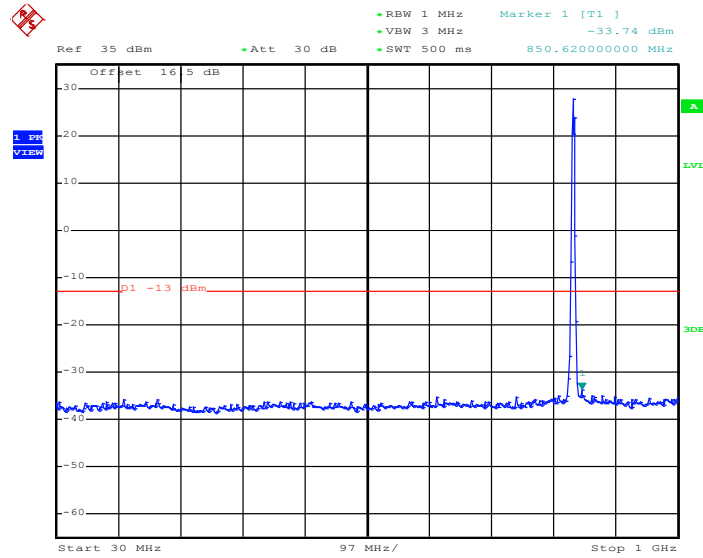

Date: 24.MAY.2013 14:11:17

Conducted Spurious Emission Plot between 1GHz ~ 3GHz

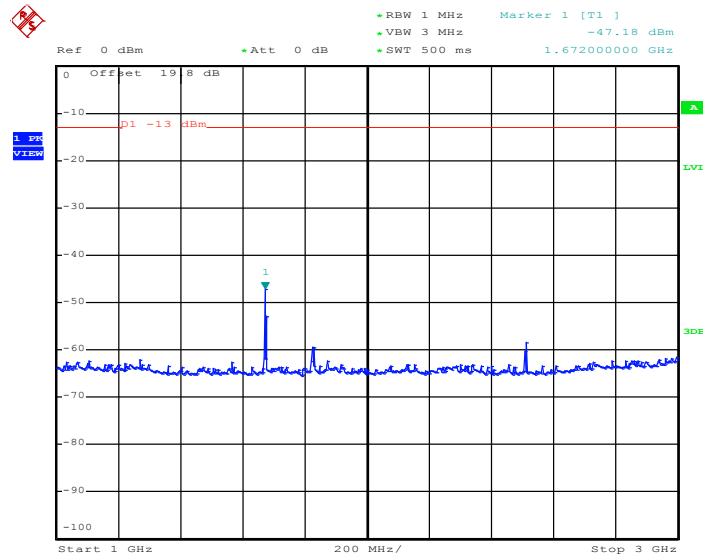

Date: 24.MAY.2013 14:04:13





### Conducted Spurious Emission Plot between 3GHz ~ 7GHz

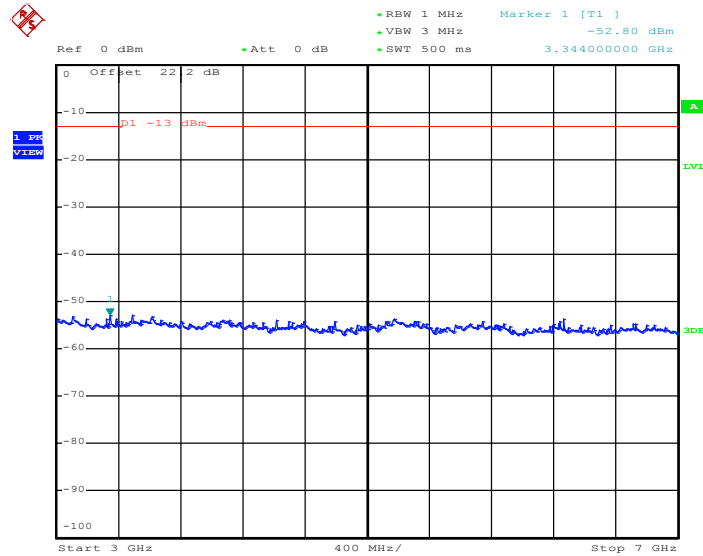

Date: 24.MAY.2013 14:04:26

### Conducted Spurious Emission Plot between 7GHz ~ 9GHz

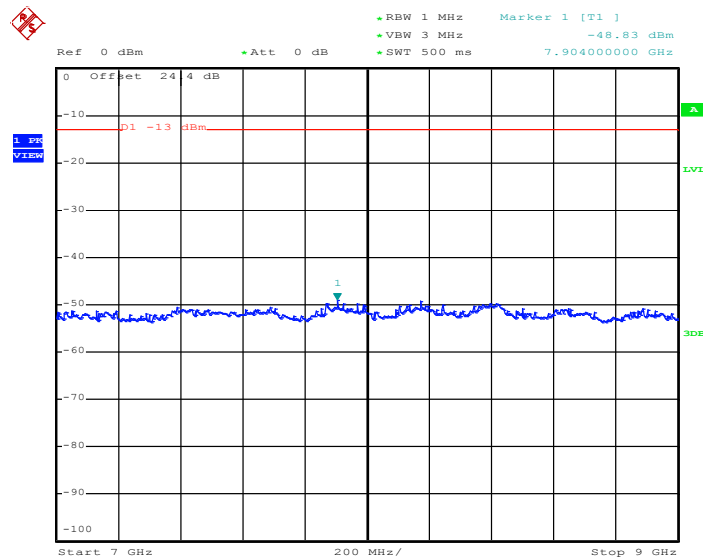

Date: 24.MAY.2013 14:04:38



|             |                       |             |            |
|-------------|-----------------------|-------------|------------|
| Band :      | CDMA2000 BC1          | Channel     | 600        |
| Test Mode : | 1xRTT_RC1+SO55 (QPSK) | Frequency : | 1880.0 MHz |

Conducted Spurious Emission Plot between 30MHz ~ 1GHz

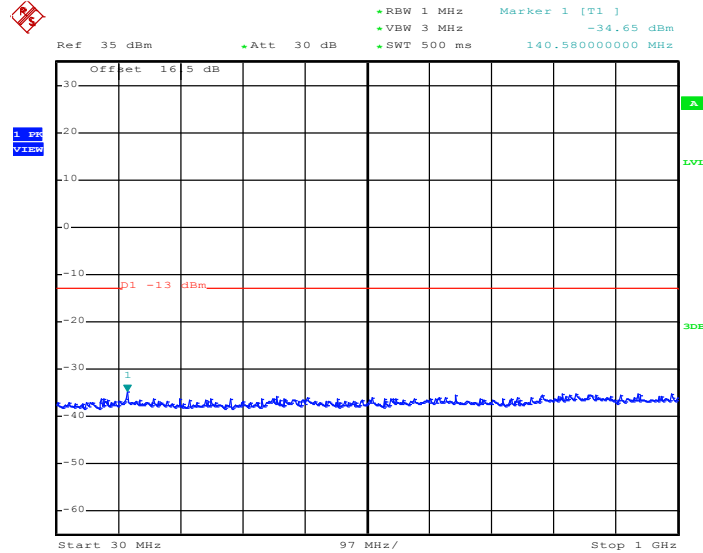

Date: 24.MAY.2013 14:14:50

Conducted Spurious Emission Plot between 1GHz ~ 3GHz

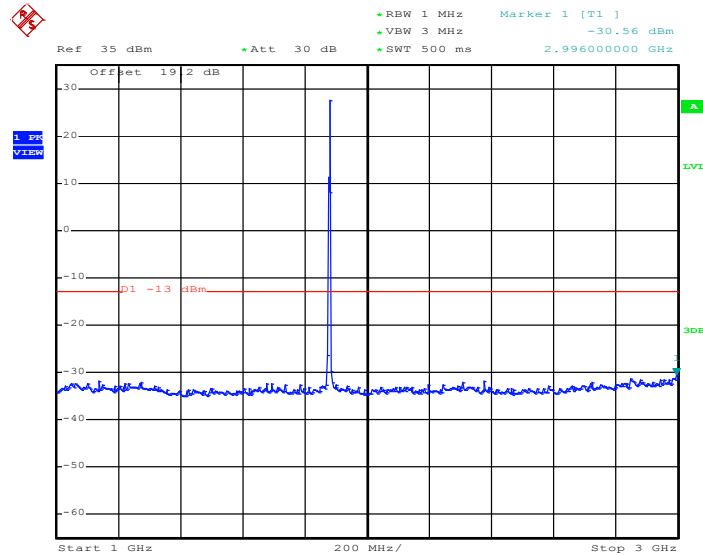

Date: 24.MAY.2013 14:15:03



### Conducted Spurious Emission Plot between 3GHz ~ 7GHz

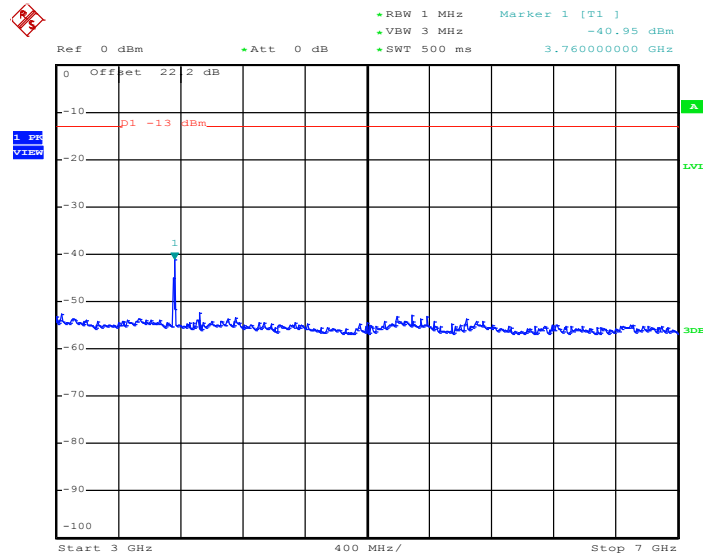

Date: 24.MAY.2013 14:15:20

### Conducted Spurious Emission Plot between 7GHz ~ 13.6GHz

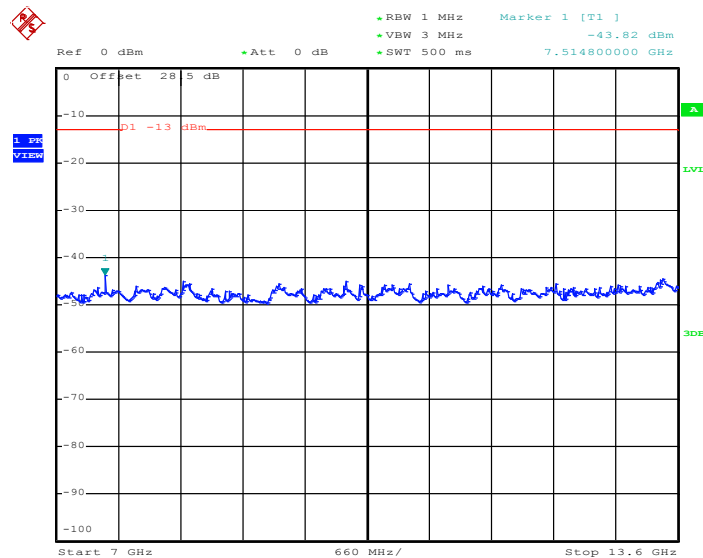

Date: 24.MAY.2013 14:15:32



Conducted Spurious Emission Plot between 13.6GHz ~ 19.1GHz

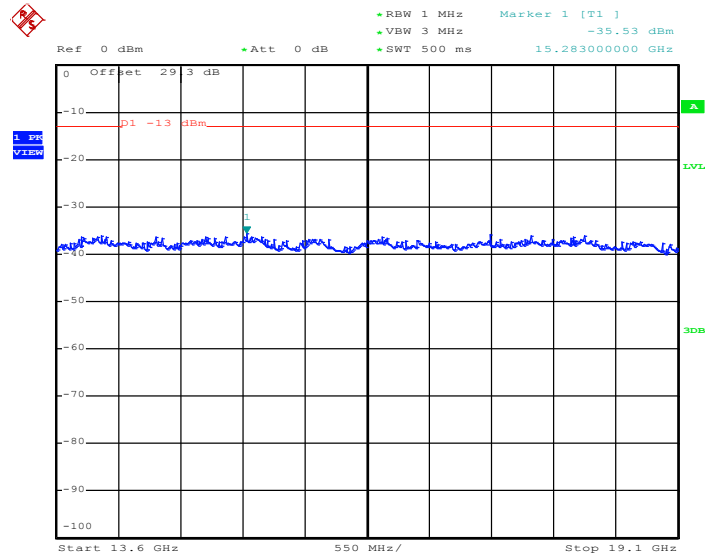

Date: 24.MAY.2013 14:15:45

## 3.6 Field Strength of Spurious Radiation Measurement

### 3.6.1 Description of Field Strength of Spurious Radiated Measurement

The power of any emission outside of the authorized operating frequency ranges must be attenuated below the transmitter power (P) by a factor of at least  $43+10\log_{10}(P[\text{Watts}])$  dB. The spectrum is scanned from 30 MHz up to a frequency including its 10th harmonic.

### 3.6.2 Measuring Instruments

See list of measuring instruments of this test report.

### 3.6.3 Test Procedures

1. The EUT was placed on a rotatable wooden table with 0.8 meter above ground.
2. The EUT was set 3 meters from the receiving antenna, which was mounted on the antenna tower.
3. The table was rotated 360 degrees to determine the position of the highest spurious emission.
4. The height of the receiving antenna is varied between one meter and four meters to search the maximum spurious emission for both horizontal and vertical polarizations.
5. Make the measurement with the spectrum analyzer's RBW = 1MHz, VBW = 3MHz, taking the record of maximum spurious emission.
6. A horn antenna was substituted in place of the EUT and was driven by a signal generator.
7. Tune the output power of signal generator to the same emission level with EUT maximum spurious emission.
8. Taking the record of output power at antenna port.
9. Repeat step 7 to step 8 for another polarization.
10.  $\text{EIRP (dBm)} = \text{S.G. Power} - \text{Tx Cable Loss} + \text{Tx Antenna Gain}$
11.  $\text{ERP (dBm)} = \text{EIRP} - 2.15$
12. The RF fundamental frequency should be excluded against the limit line in the operating frequency band.
13. The limit line is derived from  $43 + 10\log(P)$  dB below the transmitter power P(Watts)  
 $= P(W) - [43 + 10\log(P)]$  (dB)  
 $= [30 + 10\log(P)]$  (dBm) -  $[43 + 10\log(P)]$  (dB)  
 $= -13\text{dBm}$ .

### 3.6.4 Test Setup

For radiated emissions below 30MHz

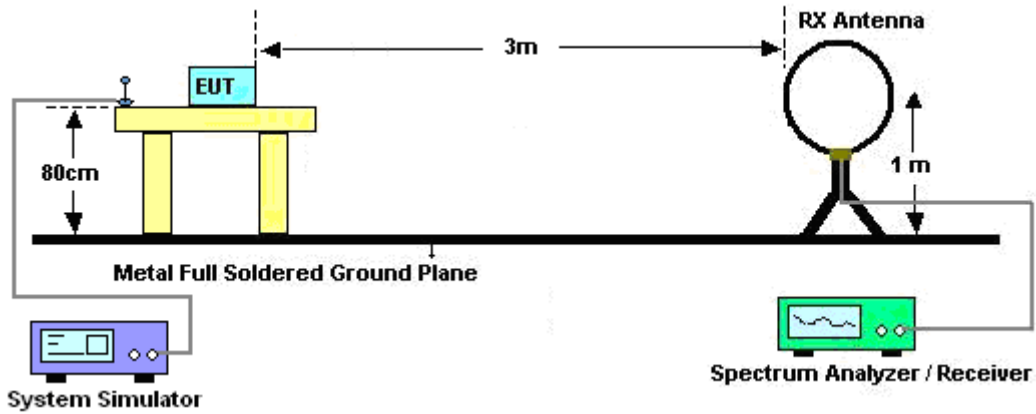

For radiated emissions from 30MHz to 1GHz

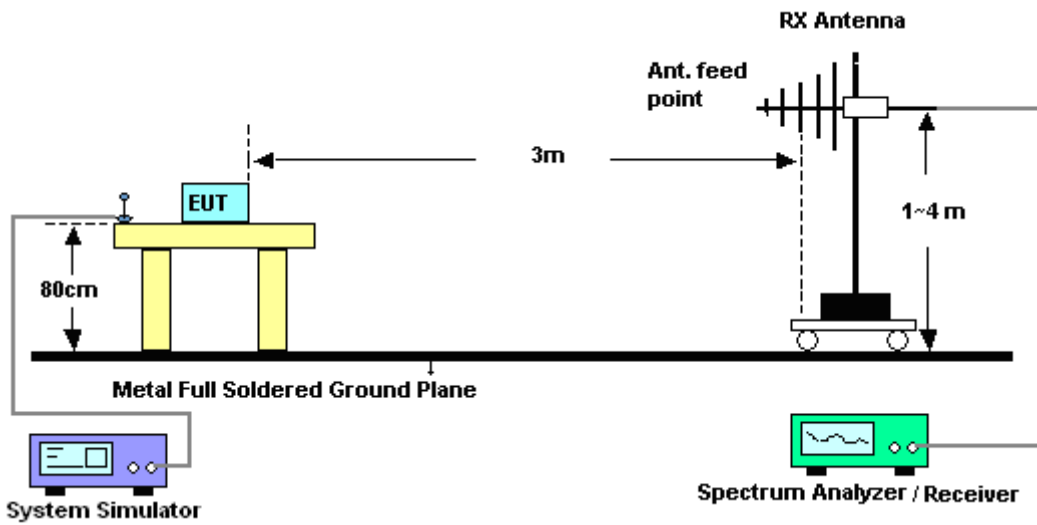

For radiated emissions above 1GHz

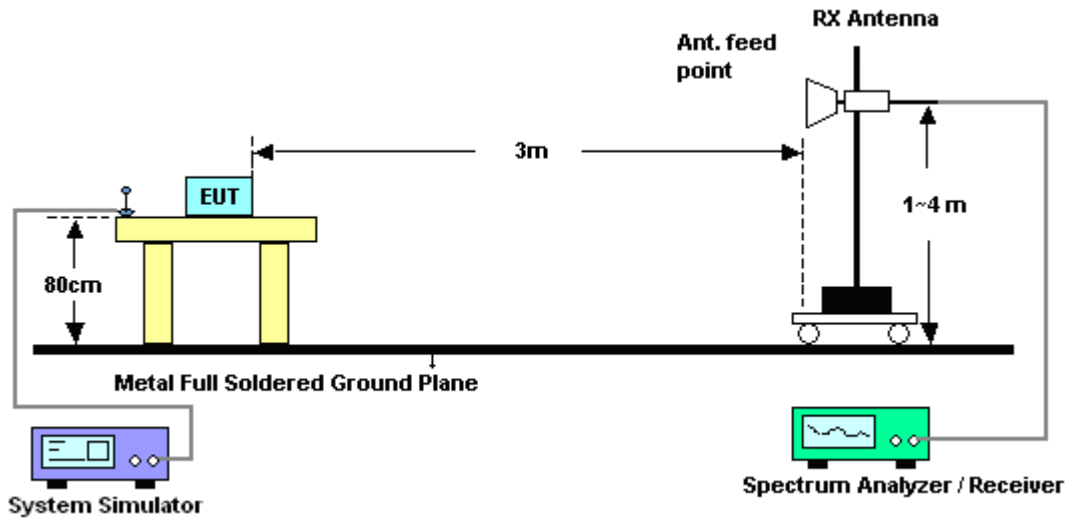

### 3.6.5 Test Results of Radiated Emissions (9 KHz ~ 30 MHz)

The low frequency, which started from 9 KHz to 30MHz, was pre-scanned and the result which was 20dB lower than the limit line per 15.31(o) was not reported.



3.6.6 Test Result of Field Strength of Spurious Radiated

|                        |                                                                                  |                            |            |
|------------------------|----------------------------------------------------------------------------------|----------------------------|------------|
| <b>Band :</b>          | CDMA2000 BC0                                                                     | <b>Temperature :</b>       | 21~23°C    |
| <b>Test Mode :</b>     | 1xRTT_RC1+SO55 (QPSK) + DC 12V                                                   | <b>Relative Humidity :</b> | 52~54%     |
| <b>Test Engineer :</b> | Beer Chang                                                                       | <b>Polarization :</b>      | Horizontal |
| <b>Remark :</b>        | Spurious emissions within 30-1000MHz were found more than 20dB below limit line. |                            |            |

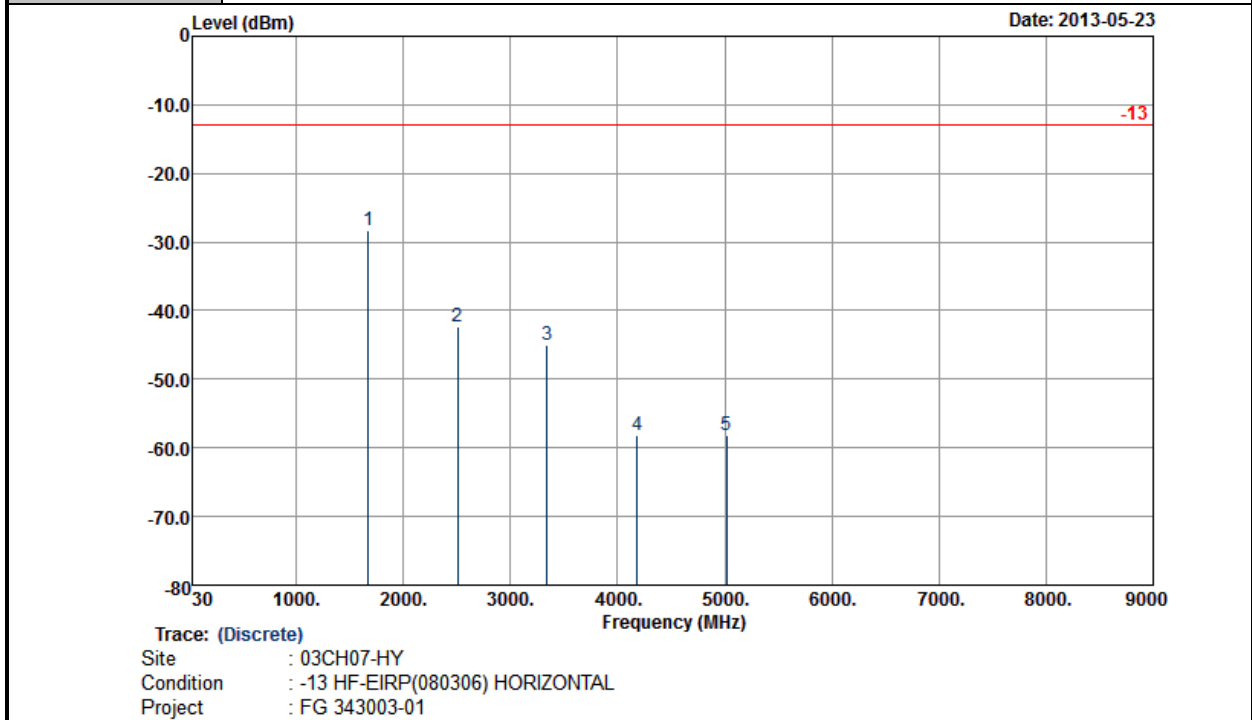

| Frequency ( MHz ) | ERP ( dBm ) | Limit ( dBm ) | Over Limit ( dB ) | SPA Reading ( dBm ) | S.G. Power ( dBm ) | TX Cable loss ( dB ) | TX Antenna Gain ( dBi ) | Polarization ( H/V ) | Result |
|-------------------|-------------|---------------|-------------------|---------------------|--------------------|----------------------|-------------------------|----------------------|--------|
| 1672              | -28.38      | -13           | -15.38            | -37.65              | -30.1              | 1.62                 | 5.49                    | H                    | Pass   |
| 2509              | -42.43      | -13           | -29.43            | -56.71              | -44.4              | 2.1                  | 6.22                    | H                    | Pass   |
| 3345              | -45.01      | -13           | -32.01            | -60.22              | -47.9              | 3.03                 | 8.07                    | H                    | Pass   |
| 4182              | -58.06      | -13           | -45.06            | -75.32              | -62.6              | 2.52                 | 9.21                    | H                    | Pass   |
| 5018              | -58.15      | -13           | -45.15            | -77.34              | -63.6              | 3.1                  | 10.70                   | H                    | Pass   |





|                        |                                                                                  |                            |          |
|------------------------|----------------------------------------------------------------------------------|----------------------------|----------|
| <b>Band :</b>          | CDMA2000 BC0                                                                     | <b>Temperature :</b>       | 21~23°C  |
| <b>Test Mode :</b>     | 1xRTT_RC1+SO55 (QPSK) + DC 12V                                                   | <b>Relative Humidity :</b> | 52~54%   |
| <b>Test Engineer :</b> | Beer Chang                                                                       | <b>Polarization :</b>      | Vertical |
| <b>Remark :</b>        | Spurious emissions within 30-1000MHz were found more than 20dB below limit line. |                            |          |

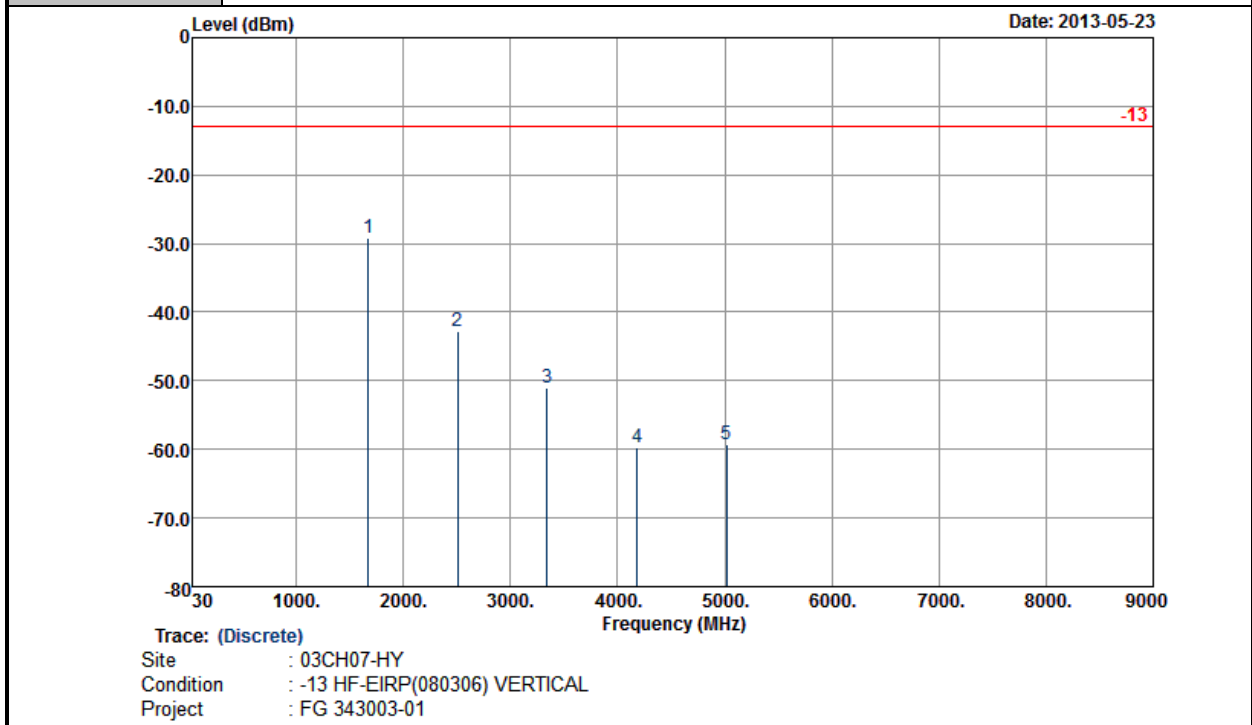

| Frequency ( MHz ) | ERP ( dBm ) | Limit ( dBm ) | Over Limit ( dB ) | SPA Reading ( dBm ) | S.G. Power ( dBm ) | TX Cable loss ( dB ) | TX Antenna Gain ( dBi ) | Polarization ( H/V ) | Result |
|-------------------|-------------|---------------|-------------------|---------------------|--------------------|----------------------|-------------------------|----------------------|--------|
| 1672              | -29.18      | -13           | -16.18            | -40.5               | -30.9              | 1.62                 | 5.49                    | V                    | Pass   |
| 2509              | -42.83      | -13           | -29.83            | -57.17              | -44.8              | 2.1                  | 6.22                    | V                    | Pass   |
| 3345              | -51.01      | -13           | -38.01            | -66.99              | -53.9              | 3.03                 | 8.07                    | V                    | Pass   |
| 4182              | -59.66      | -13           | -46.66            | -77.82              | -64.2              | 2.52                 | 9.21                    | V                    | Pass   |
| 5018              | -59.35      | -13           | -46.35            | -78.21              | -64.8              | 3.1                  | 10.70                   | V                    | Pass   |



|                        |                                                                                  |                            |            |
|------------------------|----------------------------------------------------------------------------------|----------------------------|------------|
| <b>Band :</b>          | CDMA2000 BC0                                                                     | <b>Temperature :</b>       | 21~23°C    |
| <b>Test Mode :</b>     | 1xRTT_RC1+SO55 (QPSK) + DC 24V                                                   | <b>Relative Humidity :</b> | 52~54%     |
| <b>Test Engineer :</b> | Beer Chang                                                                       | <b>Polarization :</b>      | Horizontal |
| <b>Remark :</b>        | Spurious emissions within 30-1000MHz were found more than 20dB below limit line. |                            |            |

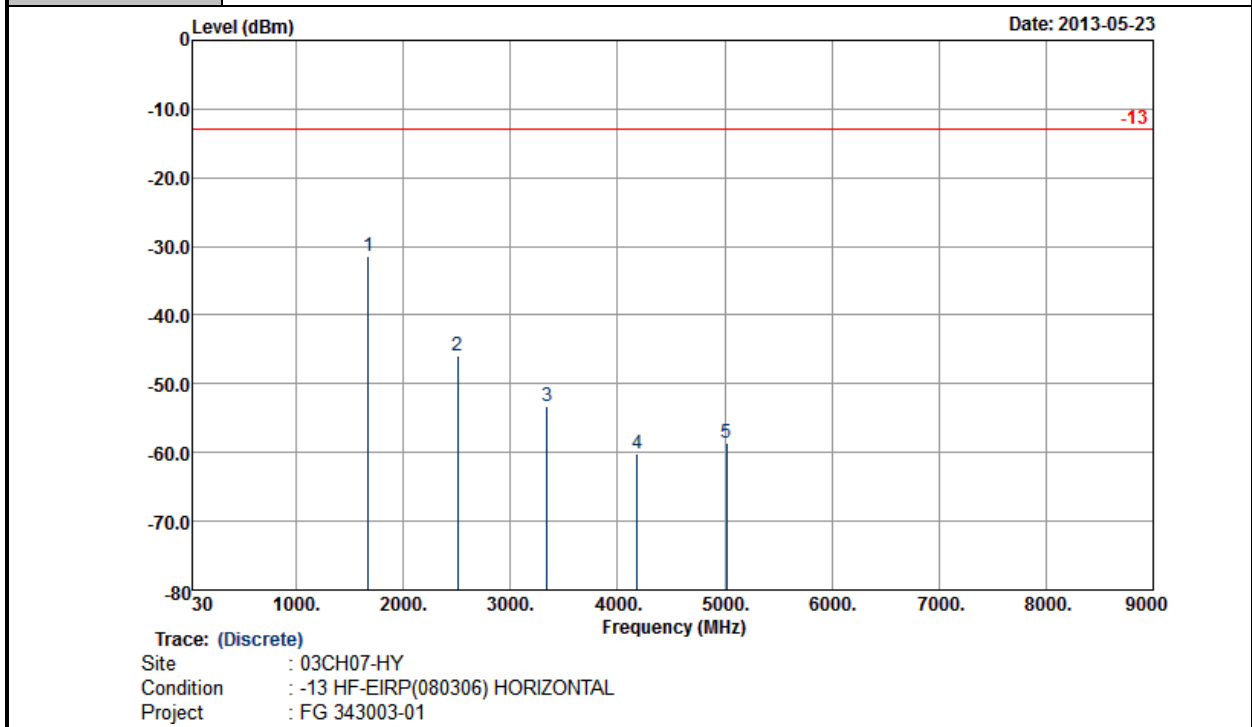

| Frequency ( MHz ) | ERP ( dBm ) | Limit ( dBm ) | Over Limit ( dB ) | SPA Reading ( dBm ) | S.G. Power ( dBm ) | TX Cable loss ( dB ) | TX Antenna Gain ( dBi ) | Polarization ( H/V ) | Result |
|-------------------|-------------|---------------|-------------------|---------------------|--------------------|----------------------|-------------------------|----------------------|--------|
| 1672              | -31.38      | -13           | -18.38            | -40.86              | -33.1              | 1.62                 | 5.49                    | H                    | Pass   |
| 2509              | -45.93      | -13           | -32.93            | -59.33              | -47.9              | 2.1                  | 6.22                    | H                    | Pass   |
| 3345              | -53.21      | -13           | -40.21            | -68.7               | -56.1              | 3.03                 | 8.07                    | H                    | Pass   |
| 4182              | -60.26      | -13           | -47.26            | -77.51              | -64.8              | 2.52                 | 9.21                    | H                    | Pass   |
| 5018              | -58.65      | -13           | -45.65            | -77.75              | -64.1              | 3.1                  | 10.70                   | H                    | Pass   |



|                        |                                                                                  |                            |          |
|------------------------|----------------------------------------------------------------------------------|----------------------------|----------|
| <b>Band :</b>          | CDMA2000 BC0                                                                     | <b>Temperature :</b>       | 21~23°C  |
| <b>Test Mode :</b>     | 1xRTT_RC1+SO55 (QPSK) + DC 24V                                                   | <b>Relative Humidity :</b> | 52~54%   |
| <b>Test Engineer :</b> | Beer Chang                                                                       | <b>Polarization :</b>      | Vertical |
| <b>Remark :</b>        | Spurious emissions within 30-1000MHz were found more than 20dB below limit line. |                            |          |

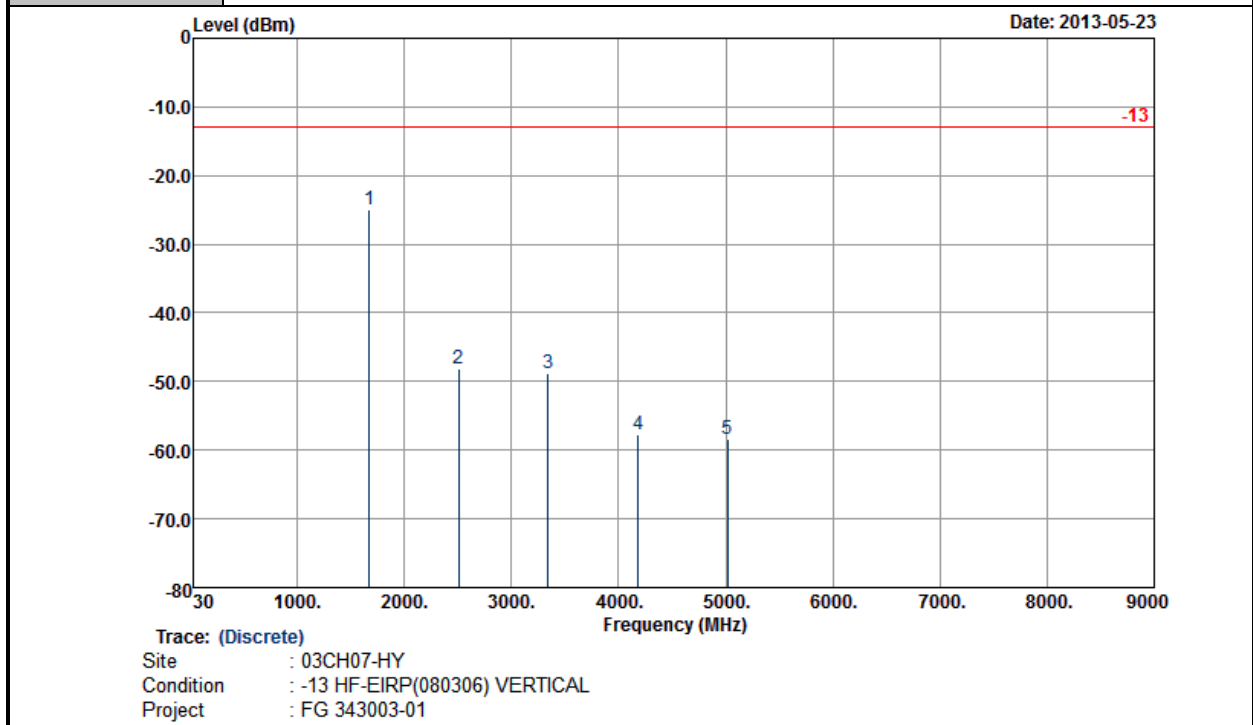

| Frequency ( MHz ) | ERP ( dBm ) | Limit ( dBm ) | Over Limit ( dB ) | SPA Reading ( dBm ) | S.G. Power ( dBm ) | TX Cable loss ( dB ) | TX Antenna Gain ( dBi ) | Polarization ( H/V ) | Result |
|-------------------|-------------|---------------|-------------------|---------------------|--------------------|----------------------|-------------------------|----------------------|--------|
| 1672              | -24.88      | -13           | -11.88            | -36.62              | -26.6              | 1.62                 | 5.49                    | V                    | Pass   |
| 2509              | -48.23      | -13           | -35.23            | -62.8               | -50.2              | 2.1                  | 6.22                    | V                    | Pass   |
| 3345              | -48.81      | -13           | -35.81            | -64.79              | -51.7              | 3.03                 | 8.07                    | V                    | Pass   |
| 4182              | -57.66      | -13           | -44.66            | -76.34              | -62.2              | 2.52                 | 9.21                    | V                    | Pass   |
| 5018              | -58.45      | -13           | -45.45            | -77.95              | -63.9              | 3.1                  | 10.70                   | V                    | Pass   |



|                        |                                                                                  |                            |            |
|------------------------|----------------------------------------------------------------------------------|----------------------------|------------|
| <b>Band :</b>          | CDMA2000 BC1                                                                     | <b>Temperature :</b>       | 21~23°C    |
| <b>Test Mode :</b>     | 1xRTT_RC1+SO55 (QPSK) + DC 12V                                                   | <b>Relative Humidity :</b> | 52~54%     |
| <b>Test Engineer :</b> | Beer Chang                                                                       | <b>Polarization :</b>      | Horizontal |
| <b>Remark :</b>        | Spurious emissions within 30-1000MHz were found more than 20dB below limit line. |                            |            |

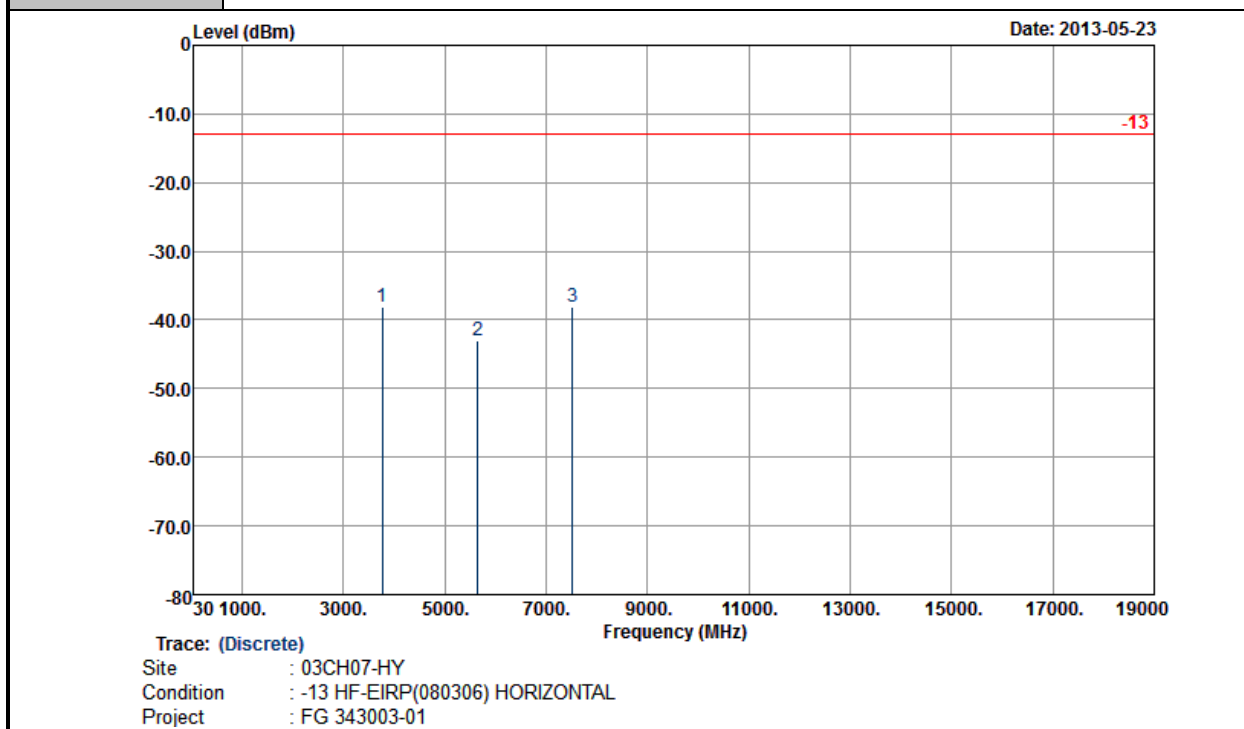

| Frequency ( MHz ) | EIRP ( dBm ) | Limit ( dBm ) | Over Limit ( dB ) | SPA Reading ( dBm ) | S.G. Power ( dBm ) | TX Cable loss ( dB ) | TX Antenna Gain ( dBi ) | Polarization ( H/V ) | Result |
|-------------------|--------------|---------------|-------------------|---------------------|--------------------|----------------------|-------------------------|----------------------|--------|
| 3760              | -38.21       | -13           | -25.21            | -53.56              | -44.51             | 2.51                 | 8.81                    | H                    | Pass   |
| 5640              | -42.95       | -13           | -29.95            | -63.71              | -50.66             | 2.99                 | 10.70                   | H                    | Pass   |
| 7520              | -38.15       | -13           | -25.15            | -65.42              | -46.68             | 3.59                 | 12.12                   | H                    | Pass   |



|                        |                                                                                  |                            |          |
|------------------------|----------------------------------------------------------------------------------|----------------------------|----------|
| <b>Band :</b>          | CDMA2000 BC1                                                                     | <b>Temperature :</b>       | 21~23°C  |
| <b>Test Mode :</b>     | 1xRTT_RC1+SO55 (QPSK) + DC 12V                                                   | <b>Relative Humidity :</b> | 52~54%   |
| <b>Test Engineer :</b> | Beer Chang                                                                       | <b>Polarization :</b>      | Vertical |
| <b>Remark :</b>        | Spurious emissions within 30-1000MHz were found more than 20dB below limit line. |                            |          |

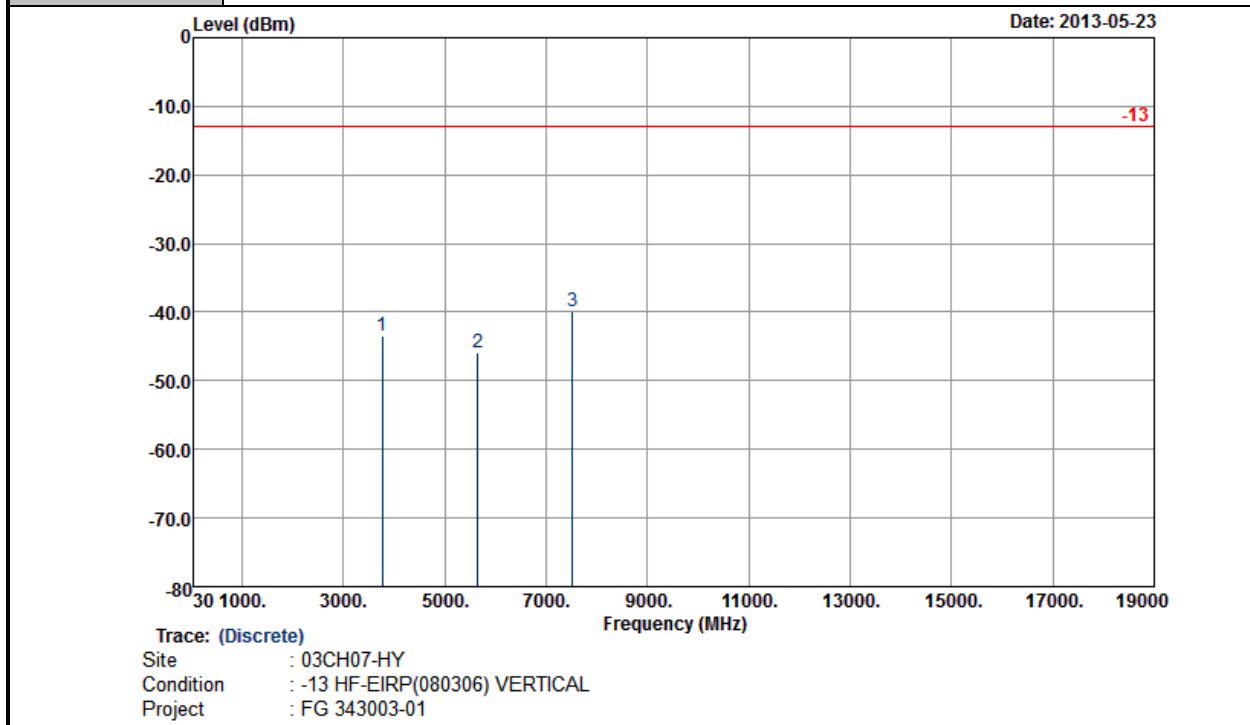

| Frequency ( MHz ) | EIRP ( dBm ) | Limit ( dBm ) | Over Limit ( dB ) | SPA Reading ( dBm ) | S.G. Power ( dBm ) | TX Cable loss ( dB ) | TX Antenna Gain ( dBi ) | Polarization ( H/V ) | Result |
|-------------------|--------------|---------------|-------------------|---------------------|--------------------|----------------------|-------------------------|----------------------|--------|
| 3760              | -43.38       | -13           | -30.38            | -59.68              | -49.68             | 2.51                 | 8.81                    | V                    | Pass   |
| 5640              | -45.95       | -13           | -32.95            | -66.52              | -53.66             | 2.99                 | 10.70                   | V                    | Pass   |
| 7520              | -39.90       | -13           | -26.90            | -66.95              | -48.43             | 3.59                 | 12.12                   | V                    | Pass   |



|                        |                                                                                  |                            |            |
|------------------------|----------------------------------------------------------------------------------|----------------------------|------------|
| <b>Band :</b>          | CDMA2000 BC1                                                                     | <b>Temperature :</b>       | 21~23°C    |
| <b>Test Mode :</b>     | 1xRTT_RC1+SO55 (QPSK) + DC 24V                                                   | <b>Relative Humidity :</b> | 52~54%     |
| <b>Test Engineer :</b> | Beer Chang                                                                       | <b>Polarization :</b>      | Horizontal |
| <b>Remark :</b>        | Spurious emissions within 30-1000MHz were found more than 20dB below limit line. |                            |            |

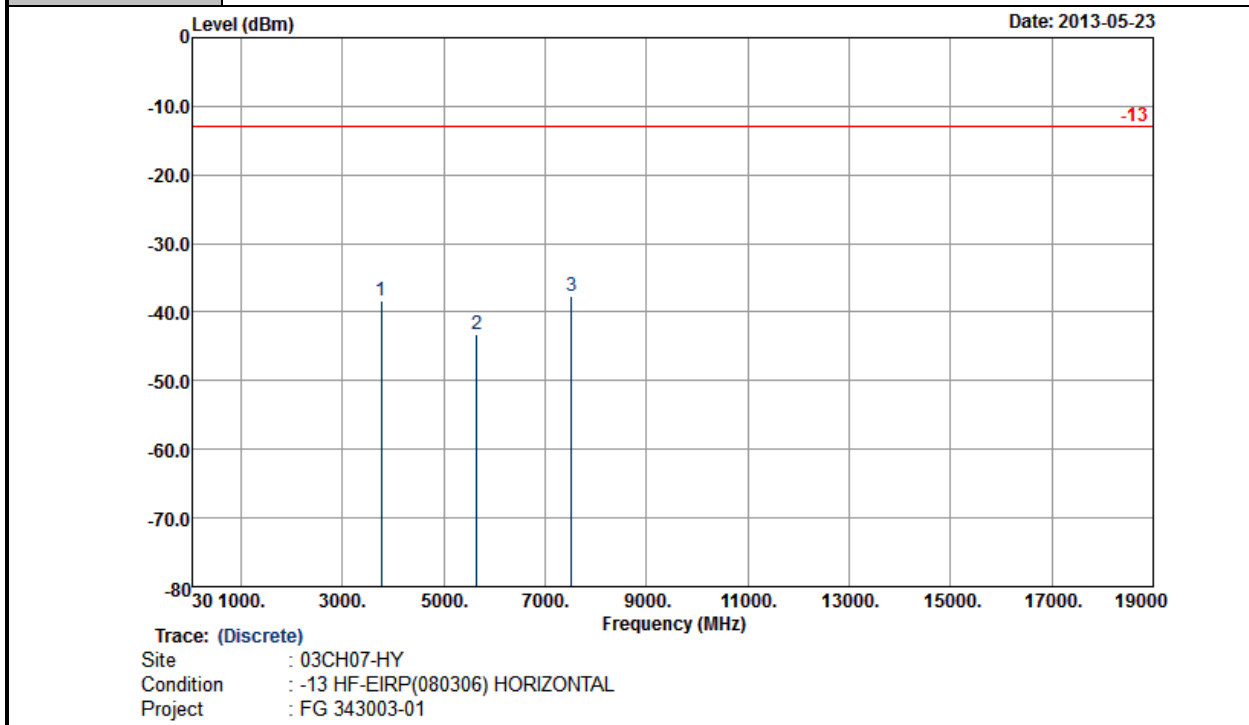

| Frequency ( MHz ) | EIRP ( dBm ) | Limit ( dBm ) | Over Limit ( dB ) | SPA Reading ( dBm ) | S.G. Power ( dBm ) | TX Cable loss ( dB ) | TX Antenna Gain ( dBi ) | Polarization ( H/V ) | Result |
|-------------------|--------------|---------------|-------------------|---------------------|--------------------|----------------------|-------------------------|----------------------|--------|
| 3760              | -38.34       | -13           | -25.34            | -53.69              | -44.64             | 2.51                 | 8.81                    | H                    | Pass   |
| 5640              | -43.15       | -13           | -30.15            | -63.91              | -50.86             | 2.99                 | 10.70                   | H                    | Pass   |
| 7520              | -37.58       | -13           | -24.58            | -64.85              | -46.11             | 3.59                 | 12.12                   | H                    | Pass   |



|                        |                                                                                  |                            |          |
|------------------------|----------------------------------------------------------------------------------|----------------------------|----------|
| <b>Band :</b>          | CDMA2000 BC1                                                                     | <b>Temperature :</b>       | 21~23°C  |
| <b>Test Mode :</b>     | 1xRTT_RC1+SO55 (QPSK) + DC 24V                                                   | <b>Relative Humidity :</b> | 52~54%   |
| <b>Test Engineer :</b> | Beer Chang                                                                       | <b>Polarization :</b>      | Vertical |
| <b>Remark :</b>        | Spurious emissions within 30-1000MHz were found more than 20dB below limit line. |                            |          |

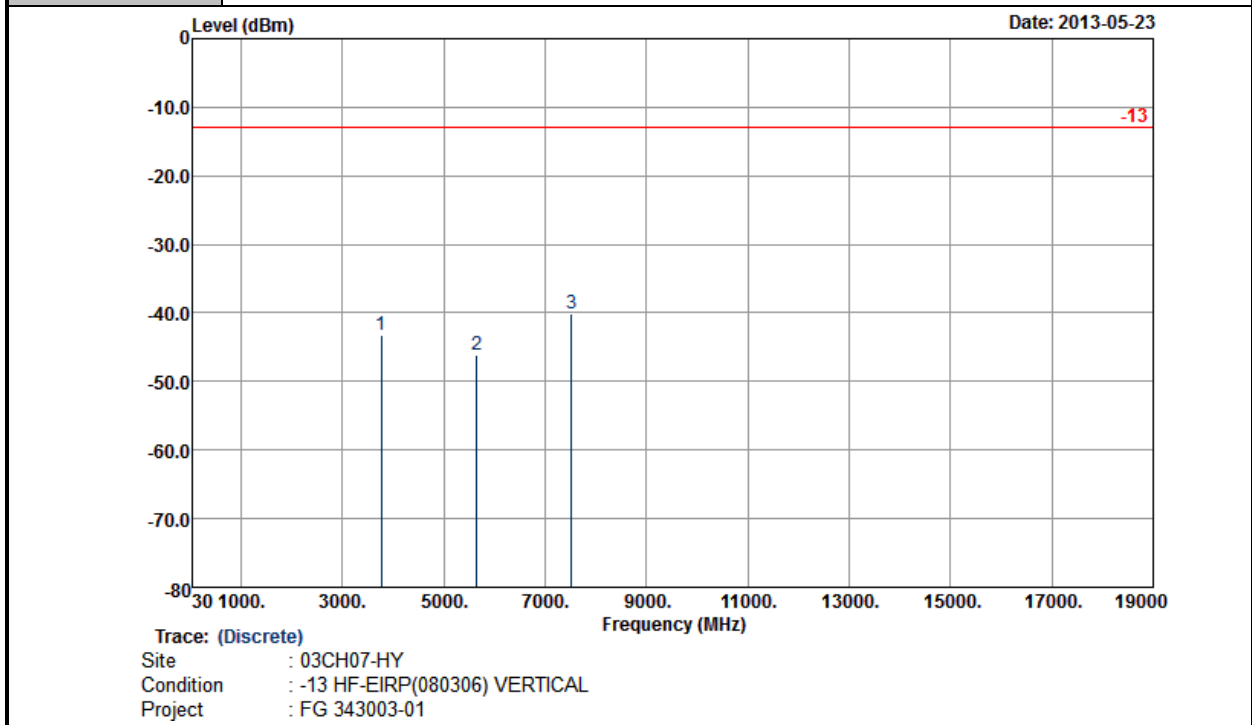

| Frequency ( MHz ) | EIRP ( dBm ) | Limit ( dBm ) | Over Limit ( dB ) | SPA Reading ( dBm ) | S.G. Power ( dBm ) | TX Cable loss ( dB ) | TX Antenna Gain ( dBi ) | Polarization ( H/V ) | Result |
|-------------------|--------------|---------------|-------------------|---------------------|--------------------|----------------------|-------------------------|----------------------|--------|
| 3760              | -43.23       | -13           | -30.23            | -59.53              | -49.53             | 2.51                 | 8.81                    | V                    | Pass   |
| 5640              | -46.02       | -13           | -33.02            | -66.59              | -53.73             | 2.99                 | 10.70                   | V                    | Pass   |
| 7520              | -40.20       | -13           | -27.20            | -67.25              | -48.73             | 3.59                 | 12.12                   | V                    | Pass   |

## 3.7 Frequency Stability Measurement

### 3.7.1 Description of Frequency Stability Measurement

The frequency stability shall be measured by variation of ambient temperature and variation of primary supply voltage to ensure that the fundamental emission stays within the authorized frequency block. The frequency stability of the transmitter shall be maintained within  $\pm 0.00025\%$  ( $\pm 2.5\text{ppm}$ ) of the center frequency.

### 3.7.2 Measuring Instruments

See list of measuring instruments of this test report.

### 3.7.3 Test Procedures for Temperature Variation

1. The EUT was set up in the thermal chamber and connected with the base station.
2. With power OFF, the temperature was decreased to  $-30^{\circ}\text{C}$  and the EUT was stabilized before testing. Power was applied and the maximum change in frequency was recorded within one minute.
3. With power OFF, the temperature was raised in  $10^{\circ}\text{C}$  step up to  $50^{\circ}\text{C}$ . The EUT was stabilized at each step for at least half an hour. Power was applied and the maximum frequency change was recorded within one minute.
4. If the EUT cannot be turned on at  $-30^{\circ}\text{C}$ , the testing lowest temperature will be raised in  $10^{\circ}\text{C}$  step until the EUT can be turned on.

### 3.7.4 Test Procedures for Voltage Variation

1. The EUT was placed in a temperature chamber at  $25\pm 5^{\circ}\text{C}$  and connected with the base station.
2. The power supply voltage to the EUT was varied from BEP to 115% of the nominal value measured at the input to the EUT.
3. The variation in frequency was measured for the worst case.

### 3.7.5 Test Setup

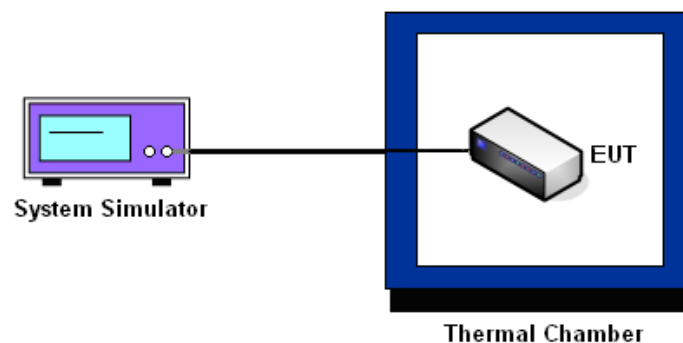





3.7.6 Test Result of Temperature Variation

|               |                             |             |            |
|---------------|-----------------------------|-------------|------------|
| Band :        | CDMA2000 BC0 1xRTT_RC1+SO55 | Channel :   | 384        |
| Limit (ppm) : | 2.5                         | Frequency : | 836.52 MHz |

| Temperature (°C) | Freq. Dev. (Hz) | Deviation (ppm) | Result |
|------------------|-----------------|-----------------|--------|
| -30              | 34              | 0.04            | PASS   |
| -20              | -31             | -0.04           |        |
| -10              | 30              | 0.04            |        |
| 0                | 28              | 0.03            |        |
| 10               | -29             | -0.03           |        |
| 20               | 30              | 0.04            |        |
| 30               | -34             | -0.04           |        |
| 40               | 35              | 0.04            |        |
| 50               | 31              | 0.04            |        |

|               |                             |             |            |
|---------------|-----------------------------|-------------|------------|
| Band :        | CDMA2000 BC1 1xRTT_RC1+SO55 | Channel :   | 600        |
| Limit (ppm) : | 2.5                         | Frequency : | 1880.0 MHz |

| Temperature (°C) | Freq. Dev. (Hz) | Deviation (ppm) | Result |
|------------------|-----------------|-----------------|--------|
| -30              | -54             | -0.03           | PASS   |
| -20              | -57             | -0.03           |        |
| -10              | 51              | 0.03            |        |
| 0                | 47              | 0.02            |        |
| 10               | -46             | -0.02           |        |
| 20               | -52             | -0.03           |        |
| 30               | -48             | -0.03           |        |
| 40               | -53             | -0.03           |        |
| 50               | -58             | -0.03           |        |



3.7.7 Test Result of Voltage Variation

| Band & Channel        | Mode              | Voltage (Volt) | Freq. Dev. (Hz) | Deviation (ppm) | Limit (ppm) | Result |
|-----------------------|-------------------|----------------|-----------------|-----------------|-------------|--------|
| CDMA2000 BC0<br>CH384 | 1xRTT<br>RC1+SO55 | 12             | -32             | -0.04           | 2.5         | PASS   |
|                       |                   | 8              | 29              | 0.03            |             |        |
|                       |                   | 40             | 30              | 0.04            |             |        |
| CDMA2000 BC1<br>CH600 | 1xRTT<br>RC1+SO55 | 12             | -51             | -0.03           | 2.5         | PASS   |
|                       |                   | 8              | -56             | -0.03           |             |        |
|                       |                   | 40             | -53             | -0.03           |             |        |

Note: Normal Voltage = 12V.



## 4 List of Measuring Equipment

| Instrument                | Manufacturer    | Model No.                | Serial No.  | Characteristics          | Calibration Date | Test Date    | Due Date      | Remark                |
|---------------------------|-----------------|--------------------------|-------------|--------------------------|------------------|--------------|---------------|-----------------------|
| System Simulator          | R&S             | CMU200                   | 117995      | N/A                      | Jul. 30, 2012    | May 24, 2013 | Jul. 29, 2013 | Conducted (TH02-HY)   |
| Spectrum Analyzer         | R&S             | FSP40                    | 100055      | 9kHz~40GHz               | Jun. 06, 2012    | May 24, 2013 | Jun. 05, 2013 | Conducted (TH02-HY)   |
| Thermal Chamber           | Ten Billion     | TTH-D3SP                 | TBN-930701  | N/A                      | Jul. 23, 2012    | May 24, 2013 | Jul. 22, 2013 | Conducted (TH02-HY)   |
| Bilog Antenna             | Schaffner       | CBL6111C                 | 2726        | 30MHz ~ 1GHz             | Oct. 06, 2012    | May 23, 2013 | Oct. 05, 2013 | Radiation (03CH07-HY) |
| Spectrum Analyzer         | Rohde & Schwarz | FSP30                    | 101067      | 9KHz ~ 30GHz             | Nov. 30, 2012    | May 23, 2013 | Nov. 29, 2013 | Radiation (03CH07-HY) |
| Double Ridge Horn Antenna | ESCO            | 3117                     | 00075962    | 1GHz ~ 18GHz             | Aug. 22, 2012    | May 23, 2013 | Aug. 21, 2013 | Radiation (03CH07-HY) |
| Preamplifier              | Agilent         | 8449B                    | 3008A02362  | 1GHz~ 26.5GHz            | Dec. 01, 2012    | May 23, 2013 | Nov. 30, 2013 | Radiation (03CH07-HY) |
| Preamplifier              | MITEQ           | AMF-7D-00<br>101800-30-1 | 159088      | 1GHz ~ 18GHz             | Feb. 27, 2013    | May 23, 2013 | Feb. 26, 2014 | Radiation (03CH07-HY) |
| Preamplifier              | COM-POWER       | PA-103A                  | 161241      | 10-1000MHz.<br>32dB.GAIN | Feb. 26, 2013    | May 23, 2013 | Feb. 25, 2014 | Radiation (03CH07-HY) |
| EMI Test Receiver         | Rohde & Schwarz | ESCI 7                   | 100724      | 9kHz~7GHz                | Sep. 03, 2012    | May 23, 2013 | Sep. 02, 2013 | Radiation (03CH07-HY) |
| SHF-EHF Horn Antenna      | SCHWARZBECK     | BBHA 9170                | BBHA9170251 | 15GHz ~ 40GHz            | Sep. 28, 2012    | May 23, 2013 | Sep. 27, 2013 | Radiation (03CH07-HY) |
| Loop Antenna              | R&S             | HFH2-Z2                  | 860004/001  | 9KHz ~ 30MHz             | Jul. 03, 2012    | May 23, 2013 | Jul. 02, 2013 | Radiation (03CH07-HY) |
| System Simulator          | R&S             | CMU200                   | 117995      | N/A                      | Jul. 28, 2011    | May 23, 2013 | Jul. 27, 2013 | Radiation (03CH07-HY) |



## 5 Uncertainty of Evaluation

### Uncertainty of Radiated Emission Measurement (30 MHz ~ 1000 MHz)

|                                                                         |      |
|-------------------------------------------------------------------------|------|
| Measuring Uncertainty for a Level of Confidence of 95% ( $U = 2Uc(y)$ ) | 2.54 |
|-------------------------------------------------------------------------|------|

### Uncertainty of Radiated Emission Measurement (1 GHz ~ 40 GHz)

|                                                                         |      |
|-------------------------------------------------------------------------|------|
| Measuring Uncertainty for a Level of Confidence of 95% ( $U = 2Uc(y)$ ) | 4.72 |
|-------------------------------------------------------------------------|------|



## **Appendix A. Photographs of EUT**

Please refer to Sporton report number EP343003-01 as below.