



RADIO TEST REPORT

Test Report No. : 12967063H-A-R1

Applicant : SUBARU CORPORATION
Type of Equipment : Keyless Access with Push-Button Start System
Model No. : SU19S-3
FCC ID : Y8PSU19S-3
Test regulation : FCC Part 15 Subpart C: 2019
Test Result : Complied (Refer to SECTION 3.2)

1. This test report shall not be reproduced in full or partial, without the written approval of UL Japan, Inc.
2. The results in this report apply only to the sample tested.
3. This sample tested is in compliance with above regulation.
4. The test results in this report are traceable to the national or international standards.
5. This test report covers Radio technical requirements. It does not cover administrative issues such as Manual or non-Radio test related Requirements. (if applicable)
6. The all test items in this test report are conducted by UL Japan, Inc. Ise EMC Lab.
7. This test report must not be used by the customer to claim product certification, approval, or endorsement by NVLAP, NIST, or any agency of the Federal Government.
8. The information provided from the customer for this report is identified in SECTION 1.
9. This report is a revised version of 12967063H-A. 12967063H-A is replaced with this report.

Date of test: July 24 and 25, 2019

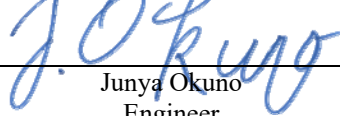
Representative test engineer: 
 Junya Okuno
 Engineer
 Consumer Technology Division

Approved by: 
 Motoya Imura
 Leader
 Consumer Technology Division



This laboratory is accredited by the NVLAP LAB CODE 200572-0, U.S.A. The tests reported herein have been performed in accordance with its terms of accreditation. *As for the range of Accreditation in NVLAP, you may refer to the WEB address, http://japan.ul.com/resources/emc_accredited/

- The testing in which "Non-accreditation" is displayed is outside the accreditation scopes in UL Japan.
 There is no testing item of "Non-accreditation".

REVISION HISTORY

Original Test Report No.: 12967063H-A

Revision	Test report No.	Date	Page revised	Contents
- (Original)	12967063H-A	September 3, 2019	-	-
1	12967063H-A-R1	November 25, 2019	P.11	Correction of erroneous description (No.8 Cable name)
1	12967063H-A-R1	November 25, 2019	P.17	Correction of erroneous description (Mode notation)
1	12967063H-A-R1	November 25, 2019	P.20	Correction of Detector in Radiated emission (above 30 MHz) data (Antenna TYPE 1); from "Hori.", "Vert." to "QP"
1	12967063H-A-R1	November 25, 2019	P.25	Addition of the note sentences under the Duty Cycle test data.

UL Japan, Inc.

Ise EMC Lab.

4383-326 Asama-cho, Ise-shi, Mie-ken 516-0021 JAPAN

Telephone : +81 596 24 8999

Facsimile : +81 596 24 8124

Reference: Abbreviations (Including words undescribed in this report)

A2LA	The American Association for Laboratory Accreditation	MRA	Mutual Recognition Arrangement
AC	Alternating Current	NIST	National Institute of Standards and Technology
AFH	Adaptive Frequency Hopping	NS	No signal detect.
AM	Amplitude Modulation	NSA	Normalized Site Attenuation
Amp, AMP	Amplifier	NVLAP	National Voluntary Laboratory Accreditation Program
ANSI	American National Standards Institute	OBW	Occupied Band Width
Ant, ANT	Antenna	OFDM	Orthogonal Frequency Division Multiplexing
AP	Access Point	OOK	On Off Keying
ASK	Amplitude Shift Keying	P/M	Power meter
Atten., ATT	Attenuator	PCB	Printed Circuit Board
AV	Average	PER	Packet Error Rate
BPSK	Binary Phase-Shift Keying	PHY	Physical Layer
BR	Bluetooth Basic Rate	PK	Peak
BT	Bluetooth	PN	Pseudo random Noise
BT LE	Bluetooth Low Energy	PRBS	Pseudo-Random Bit Sequence
BW	BandWidth	PSD	Power Spectral Density
Cal Int	Calibration Interval	QAM	Quadrature Amplitude Modulation
CCK	Complementary Code Keying	QP	Quasi-Peak
Ch., CH	Channel	QPSK	Quadri-Phase Shift Keying
CISPR	Comite International Special des Perturbations Radioelectriques	RBW	Resolution Band Width
CW	Continuous Wave	RDS	Radio Data System
DBPSK	Differential BPSK	RE	Radio Equipment
DC	Direct Current	RF	Radio Frequency
DFS	Dynamic Frequency Selection	RMS	Root Mean Square
DQPSK	Differential QPSK	RSS	Radio Standards Specifications
DSSS	Direct Sequence Spread Spectrum	Rx	Receiving
EDR	Enhanced Data Rate	SA, S/A	Spectrum Analyzer
EIRP, e.i.r.p.	Equivalent Isotropically Radiated Power	SG	Signal Generator
EMC	ElectroMagnetic Compatibility	SVSWR	Site-Voltage Standing Wave Ratio
EMI	ElectroMagnetic Interference	TR	Test Receiver
EN	European Norm	Tx	Transmitting
ERP, e.r.p.	Effective Radiated Power	VBW	Video BandWidth
EU	European Union	Vert.	Vertical
EUT	Equipment Under Test	WLAN	Wireless LAN
Fac.	Factor		
FCC	Federal Communications Commission		
FHSS	Frequency Hopping Spread Spectrum		
FM	Frequency Modulation		
Freq.	Frequency		
FSK	Frequency Shift Keying		
GFSK	Gaussian Frequency-Shift Keying		
GNSS	Global Navigation Satellite System		
GPS	Global Positioning System		
Hori.	Horizontal		
ICES	Interference-Causing Equipment Standard		
IEC	International Electrotechnical Commission		
IEEE	Institute of Electrical and Electronics Engineers		
IF	Intermediate Frequency		
ILAC	International Laboratory Accreditation Conference		
ISED	Innovation, Science and Economic Development Canada		
ISO	International Organization for Standardization		
JAB	Japan Accreditation Board		
LAN	Local Area Network		
LIMS	Laboratory Information Management System		
MCS	Modulation and Coding Scheme		

UL Japan, Inc.

Ise EMC Lab.

4383-326 Asama-cho, Ise-shi, Mie-ken 516-0021 JAPAN

Telephone : +81 596 24 8999

Facsimile : +81 596 24 8124

CONTENTS	PAGE
SECTION 1: Customer information	5
SECTION 2: Equipment under test (E.U.T.).....	5
SECTION 3: Test specification, procedures & results	7
SECTION 4: Operation of E.U.T. during testing.....	10
SECTION 5: Radiated emission (Fundamental and Spurious Emission).....	12
SECTION 6: -26dB Bandwidth.....	15
SECTION 7: 99% Occupied Bandwidth.....	15
APPENDIX 1: Test data	16
Radiated Emission below 30 MHz (Fundamental and Spurious Emission)	16
Radiated Emission above 30 MHz (Spurious Emission).....	20
Duty Cycle.....	25
-26 dB Bandwidth / 99 % Occupied Bandwidth.....	26
APPENDIX 2: Test instruments	30
APPENDIX 3: Photographs of test setup.....	31
Radiated Emission.....	31
Worst Case Position	32

UL Japan, Inc.

Ise EMC Lab.

4383-326 Asama-cho, Ise-shi, Mie-ken 516-0021 JAPAN

Telephone : +81 596 24 8999

Facsimile : +81 596 24 8124

SECTION 1: Customer information

Company Name : SUBARU CORPORATION
Address : 1-1, Subaru-cho, ota-shi, Gunma-ken, 373-8555, Japan
Telephone Number : +81-276-26-3064
Facsimile Number : +81-276-26-3878
Contact Person : Kenichi Hanamata

The information provided from the customer is as follows;

- Applicant, Type of Equipment, Model No. FCC ID on the cover and other relevant pages
 - Operating/Test Mode(s) (Mode(s)) on all the relevant pages
 - SECTION 1: Customer information
 - SECTION 2: Equipment under test (E.U.T.)
 - SECTION 4: Operation of E.U.T. during testing
- * The laboratory is exempted from liability of any test results affected from the above information in SECTION 2 and 4.

SECTION 2: Equipment under test (E.U.T.)

2.1 Identification of E.U.T.

Type of Equipment : Keyless Access with Push-Button Start System
Model No. : SU19S-3
Serial No. : Refer to Section 4, Clause 4.2
Rating : DC 12.0 V
Receipt Date of Sample : July 16, 2019
(Information from test lab.)
Country of Mass-production : Japan
Condition of EUT : Production prototype
(Not for Sale: This sample is equivalent to mass-produced items.)
Modification of EUT : No Modification by the test lab

UL Japan, Inc.

Ise EMC Lab.

4383-326 Asama-cho, Ise-shi, Mie-ken 516-0021 JAPAN

Telephone : +81 596 24 8999

Facsimile : +81 596 24 8124

2.2 Product Description

Model No: SU19S-3, (referred to as the EUT in this report), is the Keyless Access with Push-Button Start System.

Radio Specification

[Transmitter]

Radio Type	:	Transmitter
Frequency of Operation	:	134.2 kHz
Oscillator Frequency	:	4.2944 MHz
Type of Modulation	:	OOK (A1D)
Oscillation circuit	:	Crystal
Power Supply	:	DC 12.0 V
Antenna	:	Antenna (TYPE 1) (*1) (*3) / (TYPE 2) (*2) *1: Maximum number of this antenna is 2. *2: Maximum number of this antenna is 4.
Antenna Specification	:	Ferrite antenna coil
Clock frequency (maximum)	:	8.000 MHz (CPU)

*3) The Antennas (TYPE 1) of this system have variations of model 1 and model 2.

The difference of these variations is only the outer shell, and the test was performed with the representative model 1.

[Receiver]

Radio Type	:	Receiver
Frequency of Operation	:	433.92 MHz
Oscillator frequency	:	30.265 MHz (Crystal)
Intermediate frequency	:	280 kHz
Type of Modulation	:	FSK
Type of receiving system	:	Super-heterodyne
Power Supply	:	DC 5.0 V
Antenna Type	:	Internal antenna (Inverted F antenna)
Voltage Controlled Oscillator	:	1734.54 MHz

UL Japan, Inc.

Ise EMC Lab.

4383-326 Asama-cho, Ise-shi, Mie-ken 516-0021 JAPAN

Telephone : +81 596 24 8999

Facsimile : +81 596 24 8124

SECTION 3: Test specification, procedures & results

3.1 Test Specification

Test Specification : FCC Part 15 Subpart C
FCC Part 15 final revised on July 19, 2019 and effective August 19, 2019 except 15.258

Title : FCC 47CFR Part15 Radio Frequency Device Subpart C Intentional Radiators
Section 15.207 Conducted limits
Section 15.209 Radiated emission limits; general requirements.

* The revisions made after testing date do not affect the test specification applied to the EUT.

3.2 Procedures and results

Item	Test Procedure	Specification	Remarks	Deviation	Worst margin	Results
Conducted Emission	<FCC> ANSI C63.10:2013 6 Standard test methods <IC> RSS-Gen 8.8	<FCC> Section 15.207 <IC> RSS-Gen 8.8	-	N/A	N/A *1)	N/A
Electric Field Strength of Fundamental Emission	<FCC> ANSI C63.10:2013 6 Standard test methods <IC> RSS-Gen 6.5, 6.12	<FCC> Section 15.209 <IC> RSS-210 4.4 RSS-Gen 8.9	Radiated	N/A	4.5 dB 134.2 kHz 0 deg. PK with Duty factor (Antenna Type 2 LUGGAGE 2)	Complied# a)
Electric Field Strength of Spurious Emission	<FCC> ANSI C63.10:2013 6 Standard test methods <IC> RSS-Gen 6.5, 6.6, 6.13	<FCC> Section 15.209 <IC> RSS-210 4.4 RSS-Gen 8.9	Radiated	N/A	13.0 dB 30.790 MHz, Vertical, QP (Antenna Type 2 LUGGAGE 2)	Complied a)
-26dB Bandwidth	<FCC> ANSI C63.10:2013 6 Standard test methods <IC> -	<FCC> Reference data <IC> -	Radiated	N/A	N/A	Complied b)

Note: UL Japan, Inc.'s EMI Work Procedures No. 13-EM-W0420 and 13-EM-W0422.

*1) The test is not applicable since the EUT is not the device that is designed to be connected to the public utility (AC) power line.

a) Refer to APPENDIX 1 (data of Radiated emission)

b) Refer to APPENDIX 1 (data of -26 dB Bandwidth)

Symbols:

Complied The data of this test item has enough margin, more than the measurement uncertainty.

Complied# The data of this test item meets the limits unless the measurement uncertainty is taken into consideration.

FCC Part 15.31 (e)

The test was performed with the New Battery and the EUT constantly provides the stable voltage to RF part through the regulator regardless of input voltage from New Battery. Refer to technical document for supply voltage. Therefore, this EUT complies with the requirement.

FCC Part 15.203 Antenna requirement

It is impossible for end users to replace the antenna, because the antenna is mounted inside of the vehicle. Therefore, the equipment complies with the antenna requirement of Section 15.203.

UL Japan, Inc.

Ise EMC Lab.

4383-326 Asama-cho, Ise-shi, Mie-ken 516-0021 JAPAN

Telephone : +81 596 24 8999

Facsimile : +81 596 24 8124

3.3 Addition to standard

Item	Test Procedure	Specification	Remarks	Deviation	Worst margin	Results
99 % Occupied Band Width	RSS-Gen 6.7	-	Radiated	N/A	N/A	-

Note: UL Japan, Inc.'s EMI Work Procedures No. 13-EM-W0420 and 13-EM-W0422.

Other than above, no addition, exclusion nor deviation has been made from the standard.

3.4 Uncertainty

There is no applicable rule of uncertainty in this applied standard. Therefore, the following results are derived depending on whether or not laboratory uncertainty is applied.

The following uncertainties have been calculated to provide a confidence level of 95% using a coverage factor k=2.

Test distance	Radiated emission (+/-)
	9 kHz to 30 MHz
3 m*	3.3 dB
10 m*	3.2 dB

*Measurement distance

Polarity	Radiated emission (Below 1 GHz)			
	(3 m*)(+/-)		(10 m*)(+/-)	
	30 MHz to 200 MHz	200 MHz to 1000 MHz	30 MHz to 200 MHz	200 MHz to 1000 MHz
Horizontal	4.8 dB	5.2 dB	4.8 dB	5.0 dB
Vertical	5.0 dB	6.3 dB	4.9 dB	5.0 dB

Radiated emission (Above 1 GHz)				
(3 m*)(+/-)		(1 m*)(+/-)		(10 m*)(+/-)
1 GHz to 6 GHz	6 GHz to 18 GHz	10 GHz to 26.5 GHz	26.5 GHz to 40 GHz	1 GHz to 18 GHz
5.0 dB	5.3 dB	5.8 dB	5.8 dB	5.2 dB

* Measurement distance

Bandwidth
0.96 %

UL Japan, Inc.

Ise EMC Lab.

4383-326 Asama-cho, Ise-shi, Mie-ken 516-0021 JAPAN

Telephone : +81 596 24 8999

Facsimile : +81 596 24 8124

3.5 Test Location

UL Japan, Inc. Ise EMC Lab.

*NVLAP Lab. code: 200572-0 / FCC Test Firm Registration Number: 199967 / ISED Lab Company Number: 2973C

4383-326 Asama-cho, Ise-shi, Mie-ken 516-0021 JAPAN

Telephone: +81 596 24 8999, Facsimile: +81 596 24 8124

Test site	Width x Depth x Height (m)	Size of reference ground plane (m) / horizontal conducting plane	Other rooms	Maximum measurement distance
No.1 semi-anechoic chamber	19.2 x 11.2 x 7.7	7.0 x 6.0	No.1 Power source room	10 m
No.2 semi-anechoic chamber	7.5 x 5.8 x 5.2	4.0 x 4.0	-	3 m
No.3 semi-anechoic chamber	12.0 x 8.5 x 5.9	6.8 x 5.75	No.3 Preparation room	3 m
No.3 shielded room	4.0 x 6.0 x 2.7	N/A	-	-
No.4 semi-anechoic chamber	12.0 x 8.5 x 5.9	6.8 x 5.75	No.4 Preparation room	3 m
No.4 shielded room	4.0 x 6.0 x 2.7	N/A	-	-
No.5 semi-anechoic chamber	6.0 x 6.0 x 3.9	6.0 x 6.0	-	-
No.5 measurement room	6.4 x 6.4 x 3.0	6.4 x 6.4	-	-
No.6 shielded room	4.0 x 4.5 x 2.7	4.0 x 4.5	-	-
No.6 measurement room	4.75 x 5.4 x 3.0	4.75 x 4.15	-	-
No.7 shielded room	4.7 x 7.5 x 2.7	4.7 x 7.5	-	-
No.8 measurement room	3.1 x 5.0 x 2.7	3.1 x 5.0	-	-
No.9 measurement room	8.8 x 4.6 x 2.8	2.4 x 2.4	-	-
No.11 measurement room	6.2 x 4.7 x 3.0	4.8 x 4.6	-	-

* Size of vertical conducting plane (for Conducted Emission test) : 2.0 x 2.0 m for No.1, No.2, No.3, and No.4 semi-anechoic chambers and No.3 and No.4 shielded rooms.

3.6 Test data, Test instruments, and Test set up

Refer to APPENDIX.

UL Japan, Inc.

Ise EMC Lab.

4383-326 Asama-cho, Ise-shi, Mie-ken 516-0021 JAPAN

Telephone : +81 596 24 8999

Facsimile : +81 596 24 8124

SECTION 4: Operation of E.U.T. during testing

4.1 Operating Modes

The mode is used: Transmitting mode (Tx) 134.2 kHz
* LF output power is controlled by Smart ECU.

Test mode	Remarks
1) Tx 134.2 kHz Antenna TYPE 1	-
2) Tx 134.2 kHz Antenna TYPE 2 INSIDE 1	-
3) Tx 134.2 kHz Antenna TYPE 2 LUGGAGE 2	-
4) Tx 134.2 kHz, Antenna TYPE 1 (No.1) + TYPE 1 (No.2)	simultaneous transmission (Antenna TYPE 1 (No.1) and Antenna TYPE 1(No.2))

Justification : The system was configured in typical fashion (as a customer would normally use it) for testing.

4.2 Configuration and peripherals

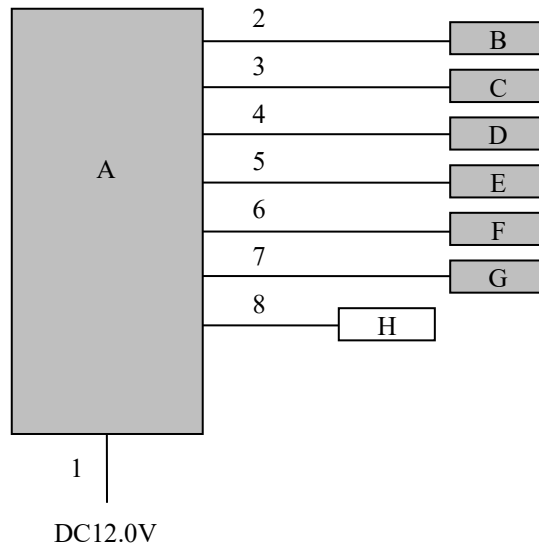

* Cabling and setup were taken into consideration and test data was taken under worse case conditions.

*This system has two kinds of antenna types.

- Two ports where Antenna (TYPE 1) are connected.
 - Four ports where Antenna (2 for TYPE 2 INSIDE and 2 for TYPE 2 LUGGAGE) are connected.
 - The difference between INSIDE 1 Antenna and LUGGAGE 2 Antenna is output power only.
- The test was performed with each representative one of above three kinds of antenna ports.

* Antenna (TYPE 1) and Antenna (TYPE 2) were evaluated with the worst duty respectively.
Worst duty does not change due to the difference in number of connected antenna.

UL Japan, Inc.

Ise EMC Lab.

4383-326 Asama-cho, Ise-shi, Mie-ken 516-0021 JAPAN

Telephone : +81 596 24 8999

Facsimile : +81 596 24 8124

Description of EUT and Support equipment

No.	Item	Model number	Serial number	Manufacturer	Remarks
A	Keyless Access with Push-Button Start System	SU19S-3	SU19S-3-8 SU19S-3-11 *1)	SUBARU CORPORATION	EUT
B	Antenna	TYPE1 (No.1)	G1234 9F7-1 2DF0	SUBARU CORPORATION	EUT
C	Antenna	TYPE1 (No.2)	G1234 9F7-3 2DF0	SUBARU CORPORATION	EUT
D	Antenna	TYPE2 INSIDE 1	8RA-189	SUBARU CORPORATION	EUT
E	Antenna	TYPE2 INSIDE 2	8RA-190	SUBARU CORPORATION	EUT
F	Antenna	TYPE2 LUGGAGE 1	8RA-191	SUBARU CORPORATION	EUT
G	Antenna	TYPE2 LUGGAGE 2	8RA-192	SUBARU CORPORATION	EUT
H	Low Frequency & Radio Frequency Bench(TYPE1)	-	001	SUBARU CORPORATION	-

*1) Simultaneous transmission with Type1 Antenna

List of cables used

No.	Name	Length (m)	Shield		Remark
			Cable	Connector	
1	DC Cable	3.0	Unshielded	Unshielded	-
2	Antenna Cable	3.0	Unshielded	Unshielded	-
3	Antenna Cable	3.0	Unshielded	Unshielded	-
4	Antenna Cable	3.0	Unshielded	Unshielded	-
5	Antenna Cable	3.0	Unshielded	Unshielded	-
6	Antenna Cable	3.0	Unshielded	Unshielded	-
7	Antenna Cable	3.0	Unshielded	Unshielded	-
8	Signal Cable	3.0	Unshielded	Unshielded	-

UL Japan, Inc.

Ise EMC Lab.

4383-326 Asama-cho, Ise-shi, Mie-ken 516-0021 JAPAN

Telephone : +81 596 24 8999

Facsimile : +81 596 24 8124

SECTION 5: Radiated emission (Fundamental and Spurious Emission)

Test Procedure

EUT was placed on a urethane platform of nominal size, 1.0 m by 1.5 m, raised 0.8 m above the conducting ground plane.

The Radiated Electric Field Strength has been measured in a Semi Anechoic Chamber with a ground plane.

Frequency : From 9 kHz to 30 MHz

The EUT was rotated a full revolution in order to obtain the maximum value of the electric field intensity.

The measurements were performed for vertical polarization (antenna angle: 0 deg., 45 deg., 90 deg., 135 deg. and 180 deg.) and horizontal polarization.

*Refer to Figure 1 about Direction of the Loop Antenna.

Frequency: From 30 MHz to 1 GHz

The measuring antenna height varied between 1 and 4 m and EUT was rotated a full revolution in order to obtain the maximum value of the electric field intensity.

The measurements were performed for both vertical and horizontal antenna polarization.

The test was made with the detector (RBW / VBW) in the following table.

When using Spectrum analyzer, the test was made with adjusting span to zero by using peak hold.

Test Antennas are used as below;

Frequency	Below 30 MHz	30 MHz to 200 MHz	200 MHz to 1 GHz
Antenna Type	Loop	Biconical	Logperiodic

Frequency	From 9 kHz to 90 kHz and From 110 kHz to 150 kHz	From 90 kHz to 110 kHz	From 150 kHz to 490 kHz	From 490 kHz to 30 MHz	From 30 MHz to 1 GHz
Instrument used	Test Receiver				
Detector	PK / AV	QP	PK / AV	QP	QP
IF Bandwidth	200 Hz	200 Hz	9 kHz	9 kHz	120 kHz
Test Distance	3 m *1)	3 m *1)	3 m *1)	3 m *2)	3 m

*1) Distance Factor: $40 \times \log(3 \text{ m} / 300 \text{ m}) = -80 \text{ dB}$

*2) Distance Factor: $40 \times \log(3 \text{ m} / 30 \text{ m}) = -40 \text{ dB}$

Although these tests were performed other than open field test site, adequate comparison measurements were confirmed against 30 m open field test site. Therefore sufficient tests were made to demonstrate that the alternative site produces results that correlate with the ones of tests made in an open field based on KDB 414788.

These tests were performed in semi anechoic chamber. Therefore the measured level of emissions may be higher than if measurements were made without a ground plane.

However test results were confirmed to pass against standard limit.

UL Japan, Inc.

Ise EMC Lab.

4383-326 Asama-cho, Ise-shi, Mie-ken 516-0021 JAPAN

Telephone : +81 596 24 8999

Facsimile : +81 596 24 8124

[Test Setup]
Below 1 GHz

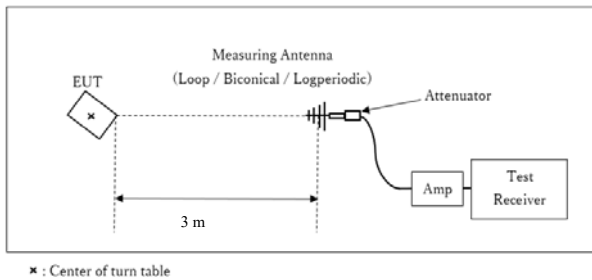

Test Distance: 3 m

- The carrier level and noise levels were confirmed at each position of X, Y and Z axes of EUT to see the position of maximum noise, and the test was made at the position that has the maximum noise.

The test results and limit are rounded off to one decimal place, so some differences might be observed.

Measurement range : 9 kHz - 1 GHz
Test data : APPENDIX 1
Test result : Pass

Date: July 24, 2019
July 25, 2019

Test engineer: Shinya Watanabe
Junya Okuno

UL Japan, Inc.

Ise EMC Lab.

4383-326 Asama-cho, Ise-shi, Mie-ken 516-0021 JAPAN

Telephone : +81 596 24 8999

Facsimile : +81 596 24 8124

Figure 1: Direction of the Loop Antenna

Side View (Vertical)

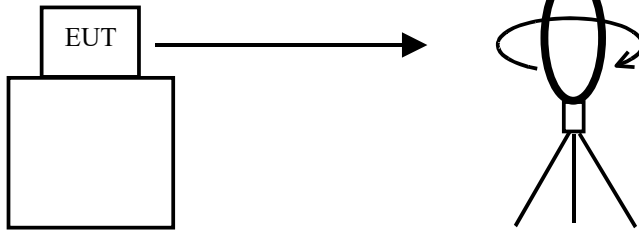

.....
Top View (Horizontal)

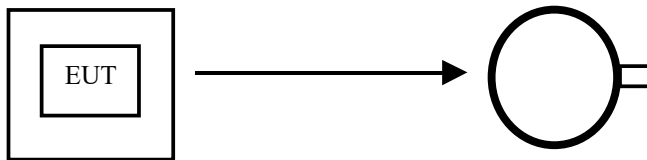

Antenna was not rotated.

.....
Top View (Vertical)

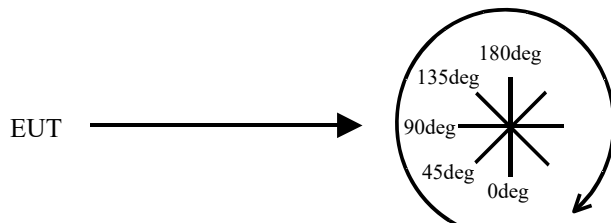

Front side: 0 deg.
Forward direction: clockwise

SECTION 6: -26dB Bandwidth

Test Procedure

The test was measured with a spectrum analyzer using a test fixture.

Test	Span	RBW	VBW	Sweep	Detector	Trace	Instrument used
-26 dB Bandwidth	200 kHz	1.8 kHz	5.6 kHz	Auto	Peak	Max Hold	Spectrum Analyzer

Test data : APPENDIX 1
Test result : Pass

SECTION 7: 99% Occupied Bandwidth

Test Procedure

The test was measured with a spectrum analyzer using a test fixture.

Test	Span	RBW	VBW	Sweep	Detector	Trace	Instrument used
99 % Occupied Bandwidth	Enough width to display emission skirts	1 to 5 % of OBW	Three times of RBW	Auto	Peak	Max Hold	Spectrum Analyzer
Peak hold was applied as Worst-case measurement.							

Test data : APPENDIX 1
Test result : Pass

UL Japan, Inc.

Ise EMC Lab.

4383-326 Asama-cho, Ise-shi, Mie-ken 516-0021 JAPAN

Telephone : +81 596 24 8999

Facsimile : +81 596 24 8124

APPENDIX 1: Test data

Radiated Emission below 30 MHz (Fundamental and Spurious Emission)

Antenna TYPE 1

Report No. 12967063H
Test place Ise EMC Lab. No.1 Semi Anechoic Chamber
Date 07/25/2019
Temperature/ Humidity 22 deg. C / 60 % RH
Engineer Junya Okuno
Mode Tx 134.2 kHz, Antenna TYPE 1

PK or QP

Ant Deg [deg] or Polarity [Hori/Vert]	Frequency [MHz]	Detector	Reading [dBuV]	Ant Factor [dB/m]	Loss [dB]	Gain [dB]	Duty Factor [dB]	Result [dBuV/m]	Limit [dBuV/m]	Margin [dB]	Remark
0	0.13420	PK	101.0	19.7	-74.0	32.3	-	14.4	45.0	30.6	Fundamental
0	0.26840	PK	53.5	19.7	-74.0	32.3	-	-33.1	39.0	72.1	
0	0.40260	PK	75.5	19.6	-73.9	32.3	-	-11.1	35.5	46.6	
0	0.53680	QP	40.3	19.6	-33.9	32.2	-	-6.2	33.0	39.2	
0	0.67100	QP	63.4	19.6	-33.9	32.3	-	16.9	31.1	14.2	
0	0.80520	QP	36.4	19.6	-33.9	32.3	-	-10.1	29.5	39.6	
0	0.93940	QP	51.6	19.6	-33.8	32.3	-	5.1	28.1	23.0	
0	1.07360	QP	31.7	19.6	-33.8	32.3	-	-14.8	26.9	41.7	
0	1.20780	QP	42.9	19.6	-33.8	32.3	-	-3.6	25.9	29.5	
0	1.34200	QP	31.1	19.6	-33.8	32.3	-	-15.4	25.0	40.4	

Result = Reading + Ant Factor + Loss (Cable + Attenuator + Filter + D.Factor) - Gain(Amplifier)

PK with Duty factor

Ant Deg [deg]	Frequency [MHz]	Detector	Reading [dBuV]	Ant Factor [dB/m]	Loss [dB]	Gain [dB]	Duty Factor [dB]	Result [dBuV/m]	Limit [dBuV/m]	Margin [dB]	Remark
0	0.13420	PK	101.0	19.7	-74.0	32.3	0.0	14.4	25.0	10.6	
0	0.26840	PK	53.5	19.7	-74.0	32.3	0.0	-33.1	19.0	52.1	
0	0.40260	PK	75.5	19.6	-73.9	32.3	0.0	-11.1	15.5	26.6	

Result = Reading + Ant Factor + Loss (Cable + Attenuator + Filter + D.Factor) - Gain(Amplifier) + Duty factor *

* Since the peak emission result satisfied the average limit, duty factor was omitted.

Result of the fundamental emission at 3m without Distance factor

PK or QP

Ant Deg [deg]	Frequency [MHz]	Detector	Reading [dBuV]	Ant Factor [dB/m]	Loss [dB]	Gain [dB]	Duty Factor [dB]	Result [dBuV/m]	Limit [dBuV/m]	Margin [dB]	Remark
0	0.13420	PK	101.0	19.7	6.0	32.3	-	94.4	-	-	Fundamental

Result = Reading + Ant Factor + Loss (Cable+Attenuator+Filter) - Gain(Amplifier)

* Other frequency noises omitted in this report were not seen or had enough margin (more than 20 dB).

*The test result is rounded off to one or two decimal places, so some differences might be observed.

UL Japan, Inc.

Ise EMC Lab.

4383-326 Asama-cho, Ise-shi, Mie-ken 516-0021 JAPAN

Telephone : +81 596 24 8999

Facsimile : +81 596 24 8124

Radiated Emission below 30 MHz (Fundamental and Spurious Emission)

Antenna TYPE 2 INSIDE 1

Report No. 12967063H
Test place Ise EMC Lab. No.1 Semi Anechoic Chamber
Date 07/25/2019
Temperature/ Humidity 22 deg. C / 60 % RH
Engineer Junya Okuno
Mode Tx 134.2 kHz, Antenna TYPE 2 INSIDE 1

PK or QP

Ant Deg [deg] or Polarity [Hori/Vert]	Frequency [MHz]	Detector	Reading [dBuV]	Ant Factor [dB/m]	Loss [dB]	Gain [dB]	Duty Factor [dB]	Result [dBuV/m]	Limit [dBuV/m]	Margin [dB]	Remark
0	0.13420	PK	101.9	19.7	-74.0	32.3	-	15.3	45.0	29.7	Fundamental
0	0.26840	PK	75.5	19.7	-74.0	32.3	-	-11.1	39.0	50.1	
0	0.40260	PK	64.9	19.6	-73.9	32.3	-	-21.7	35.5	57.2	
0	0.53680	QP	33.5	19.6	-33.9	32.2	-	-13.0	33.0	46.0	
0	0.67100	QP	47.8	19.6	-33.9	32.3	-	1.3	31.1	29.8	
0	0.80520	QP	31.8	19.6	-33.9	32.3	-	-14.7	29.5	44.2	
0	0.93940	QP	46.7	19.6	-33.8	32.3	-	0.2	28.1	27.9	
0	1.07360	QP	31.1	19.6	-33.8	32.3	-	-15.4	26.9	42.3	
0	1.20780	QP	41.5	19.6	-33.8	32.3	-	-5.0	25.9	30.9	
0	1.34200	QP	30.9	19.6	-33.8	32.3	-	-15.6	25.0	40.6	

Result = Reading + Ant Factor + Loss (Cable + Attenuator + Filter + D.Factor) - Gain(Amplifier)

PK with Duty factor

Ant Deg [deg]	Frequency [MHz]	Detector	Reading [dBuV]	Ant Factor [dB/m]	Loss [dB]	Gain [dB]	Duty Factor [dB]	Result [dBuV/m]	Limit [dBuV/m]	Margin [dB]	Remark
0	0.13420	PK	101.9	19.7	-74.0	32.3	0.0	15.3	25.0	9.7	
0	0.26840	PK	75.5	19.7	-74.0	32.3	0.0	-11.1	19.0	30.1	
0	0.40260	PK	64.9	19.6	-73.9	32.3	0.0	-21.7	15.5	37.2	

Result = Reading + Ant Factor + Loss (Cable + Attenuator + Filter + D.Factor) - Gain(Amplifier) + Duty factor *

* Since the peak emission result satisfied the average limit, duty factor was omitted.

Result of the fundamental emission at 3m without Distance factor

PK or QP

Ant Deg [deg]	Frequency [MHz]	Detector	Reading [dBuV]	Ant Factor [dB/m]	Loss [dB]	Gain [dB]	Duty Factor [dB]	Result [dBuV/m]	Limit [dBuV/m]	Margin [dB]	Remark
0	0.13420	PK	101.9	19.7	6.0	32.3	-	95.3	-	-	Fundamental

Result = Reading + Ant Factor + Loss (Cable+Attenuator+Filter) - Gain(Amplifier)

* Other frequency noises omitted in this report were not seen or had enough margin (more than 20 dB).

*The test result is rounded off to one or two decimal places, so some differences might be observed.

UL Japan, Inc.

Ise EMC Lab.

4383-326 Asama-cho, Ise-shi, Mie-ken 516-0021 JAPAN

Telephone : +81 596 24 8999

Facsimile : +81 596 24 8124

Radiated Emission below 30 MHz (Fundamental and Spurious Emission)

Antenna TYPE 2 LUGGAGE 2

Report No. 12967063H
Test place Ise EMC Lab. No.1 Semi Anechoic Chamber
Date 07/25/2019
Temperature/ Humidity 22 deg. C / 60 % RH
Engineer Junya Okuno
Mode Tx 134.2 kHz, Antenna TYPE 2 LUGGAGE 2

PK or QP

Ant Deg [deg] or Polarity [Hori/Vert]	Frequency [MHz]	Detector	Reading [dBuV]	Ant Factor [dB/m]	Loss [dB]	Gain [dB]	Duty Factor [dB]	Result [dBuV/m]	Limit [dBuV/m]	Margin [dB]	Remark
0	0.13420	PK	111.9	19.7	-74.0	32.3	-	25.3	45.0	19.7	Fundamental
0	0.26840	PK	76.7	19.7	-74.0	32.3	-	-9.9	39.0	48.9	
0	0.40260	PK	59.1	19.6	-73.9	32.3	-	-27.5	35.5	63.0	
0	0.53680	QP	38.0	19.6	-33.9	32.2	-	-8.5	33.0	41.5	
0	0.67100	QP	52.6	19.6	-33.9	32.3	-	6.1	31.1	25.0	
0	0.80520	QP	31.9	19.6	-33.9	32.3	-	-14.6	29.5	44.1	
0	0.93940	QP	51.2	19.6	-33.8	32.3	-	4.7	28.1	23.4	
0	1.07360	QP	31.0	19.6	-33.8	32.3	-	-15.5	26.9	42.4	
0	1.20780	QP	47.8	19.6	-33.8	32.3	-	1.3	25.9	24.6	
0	1.34200	QP	30.9	19.6	-33.8	32.3	-	-15.6	25.0	40.6	

Result = Reading + Ant Factor + Loss (Cable + Attenuator + Filter + D.Factor) - Gain(Amplifier)

PK with Duty factor

Ant Deg [deg]	Frequency [MHz]	Detector	Reading [dBuV]	Ant Factor [dB/m]	Loss [dB]	Gain [dB]	Duty Factor [dB]	Result [dBuV/m]	Limit [dBuV/m]	Margin [dB]	Remark
0	0.13420	PK	111.9	19.7	-74.0	32.3	-4.7	20.5	25.0	4.5	
0	0.26840	PK	76.7	19.7	-74.0	32.3	-4.7	-14.7	19.0	33.7	
0	0.40260	PK	59.1	19.6	-73.9	32.3	-4.7	-32.2	15.5	47.7	

Result = Reading + Ant Factor + Loss (Cable + Attenuator + Filter + D.Factor) - Gain(Amplifier) + Duty factor (Refer to Duty cycle data sheet)

Result of the fundamental emission at 3m without Distance factor

PK or QP

Ant Deg [deg]	Frequency [MHz]	Detector	Reading [dBuV]	Ant Factor [dB/m]	Loss [dB]	Gain [dB]	Duty Factor [dB]	Result [dBuV/m]	Limit [dBuV/m]	Margin [dB]	Remark
0	0.13420	PK	111.9	19.7	6.0	32.3	-	105.3	-	-	Fundamental

Result = Reading + Ant Factor + Loss (Cable+Attenuator+Filter) - Gain(Amplifier)

* Other frequency noises omitted in this report were not seen or had enough margin (more than 20 dB).

*The test result is rounded off to one or two decimal places, so some differences might be observed.

UL Japan, Inc.

Ise EMC Lab.

4383-326 Asama-cho, Ise-shi, Mie-ken 516-0021 JAPAN

Telephone : +81 596 24 8999

Facsimile : +81 596 24 8124

Radiated Emission below 30 MHz (Fundamental and Spurious Emission)
Antenna TYPE 1 (No.1) + TYPE 1 (No.2)

Report No. 12967063H
Test place Ise EMC Lab. No.1 Semi Anechoic Chamber
Date 07/25/2019
Temperature/ Humidity 22 deg. C / 60 % RH
Engineer Junya Okuno
Mode Tx 134.2 kHz, Antenna TYPE 1(No.1) + TYPE 1(No.2)

PK or QP

Ant Deg [deg] or Polarity [Hori/Vert]	Frequency [MHz]	Detector	Reading [dBuV]	Ant Factor [dB/m]	Loss [dB]	Gain [dB]	Duty Factor [dB]	Result [dBuV/m]	Limit [dBuV/m]	Margin [dB]	Remark
0	0.13420	PK	101.4	19.7	-74.0	32.3	-	14.8	45.0	30.2	Fundamental
0	0.26840	PK	67.4	19.7	-73.9	32.3	-	-19.1	39.0	58.1	
0	0.40260	PK	81.6	19.6	-73.9	32.3	-	-4.9	35.5	40.4	
0	0.53680	QP	44.2	19.6	-33.9	32.2	-	-2.3	33.0	35.3	
0	0.67100	QP	65.3	19.6	-33.9	32.3	-	18.8	31.1	12.3	
0	0.80520	QP	40.4	19.6	-33.8	32.3	-	-6.1	29.5	35.6	
0	0.93940	QP	53.7	19.6	-33.8	32.3	-	7.2	28.1	20.9	
0	1.07360	QP	31.2	19.6	-33.8	32.3	-	-15.2	26.9	42.1	
0	1.20780	QP	45.2	19.6	-33.8	32.3	-	-1.3	25.9	27.2	
0	1.34200	QP	31.1	19.6	-33.8	32.3	-	-15.3	25.0	40.3	

Result = Reading + Ant Factor + Loss (Cable + Attenuator + Filter + D.Factor) - Gain(Amplifier)

PK with Duty factor

Ant Deg [deg]	Frequency [MHz]	Detector	Reading [dBuV]	Ant Factor [dB/m]	Loss [dB]	Gain [dB]	Duty Factor [dB]	Result [dBuV/m]	Limit [dBuV/m]	Margin [dB]	Remark
0	0.13420	PK	101.4	19.7	-74.0	32.3	0.0	14.8	25.0	10.2	
0	0.26840	PK	67.4	19.7	-73.9	32.3	0.0	-19.1	19.0	38.1	
0	0.40260	PK	81.6	19.6	-73.9	32.3	0.0	-4.9	15.5	20.4	

Result = Reading + Ant Factor + Loss (Cable + Attenuator + Filter + D.Factor) - Gain(Amplifier) + Duty factor *

* Since the peak emission result satisfied the average limit, duty factor was omitted.

Result of the fundamental emission at 3m without Distance factor

PK or QP

Ant Deg [deg]	Frequency [MHz]	Detector	Reading [dBuV]	Ant Factor [dB/m]	Loss [dB]	Gain [dB]	Duty Factor [dB]	Result [dBuV/m]	Limit [dBuV/m]	Margin [dB]	Remark
0	0.13420	PK	101.4	19.7	6.0	32.3	-	94.8	-	-	Fundamental

Result = Reading + Ant Factor + Loss (Cable+Attenuator+Filter) - Gain(Amplifier)

* Other frequency noises omitted in this report were not seen or had enough margin (more than 20 dB).

*The test result is rounded off to one or two decimal places, so some differences might be observed.

UL Japan, Inc.

Ise EMC Lab.

4383-326 Asama-cho, Ise-shi, Mie-ken 516-0021 JAPAN

Telephone : +81 596 24 8999

Facsimile : +81 596 24 8124

Radiated Emission above 30 MHz (Spurious Emission)

Antenna TYPE 1

Report No. 12967063H
Test place Ise EMC Lab.
Semi Anechoic Chamber No.1
Date 07/24/2019
Temperature / Humidity 21 deg. C / 53 % RH
Engineer Shinya Watanabe
(Above 30 MHz)
Mode Tx 134.2 kHz, Antenna TYPE 1

Pola. [H/V]	Frequency [MHz]	Detector	Reading [dBuV]	Ant.Fac. [dB/m]	Loss [dB]	Gain [dB]	Result [dBuV/m]	Limit [dBuV/m]	Margin [dB]	Remark
H	30.699	QP	28.6	17.7	7.4	38.9	14.7	40.0	25.3	
H	47.244	QP	29.3	11.6	7.7	38.9	9.7	40.0	30.4	
H	64.023	QP	36.5	7.0	8.0	39.0	12.5	40.0	27.5	Floor noise
H	72.995	QP	37.3	6.1	8.2	39.0	12.6	40.0	27.4	Floor noise
H	82.873	QP	32.4	6.5	8.3	39.0	8.2	40.0	31.8	
H	946.066	QP	26.1	22.0	14.9	38.1	24.9	46.0	21.1	Floor noise
V	30.879	QP	36.0	17.7	7.4	38.9	22.1	40.0	17.9	
V	47.228	QP	38.8	11.6	7.7	38.9	19.2	40.0	20.8	
V	64.143	QP	40.8	7.0	8.0	39.0	16.8	40.0	23.2	
V	72.989	QP	41.2	6.1	8.2	39.0	16.5	40.0	23.5	
V	82.894	QP	37.9	6.5	8.3	39.0	13.7	40.0	26.3	
V	946.121	QP	26.1	22.0	14.9	38.1	24.9	46.0	21.1	Floor noise

* Other frequency noises omitted in this report were not seen or had enough margin (more than 20 dB).

CHART: WITH FACTOR

ANT TYPE: - 30 MHz: LOOP, 30 MHz - 200 MHz: BICONICAL, 200 MHz - 1000 MHz: LOGPERIODIC, 1000 MHz -: HORN
CALCULATION: RESULT = READING + ANT FACTOR + LOSS (CABLE + ATT) - GAIN(AMP)

UL Japan, Inc.

Ise EMC Lab.

4383-326 Asama-cho, Ise-shi, Mie-ken 516-0021 JAPAN

Telephone : +81 596 24 8999

Facsimile : +81 596 24 8124

Radiated Emission above 30 MHz (Spurious Emission)

Antenna TYPE 2 INSIDE 1

Report No. 12967063H
Test place Ise EMC Lab.
Semi Anechoic Chamber No.1
Date 07/24/2019
Temperature / Humidity 21 deg. C / 53 % RH
Engineer Shinya Watanabe
(Above 30 MHz)
Mode Tx 134.2 kHz, Antenna TYPE 2 INSIDE 1

Pola. [H/V]	Frequency [MHz]	Detector	Reading [dBuV]	Ant.Fac. [dB/m]	Loss [dB]	Gain [dB]	Result [dBuV/m]	Limit [dBuV/m]	Margin [dB]	Remark
H	30.207	QP	27.9	17.8	7.4	38.9	14.2	40.0	25.8	
H	59.392	QP	35.3	7.8	8.0	39.0	12.1	40.0	27.9	
H	71.285	QP	32.5	6.1	8.2	39.0	7.8	40.0	32.2	
H	73.005	QP	36.0	6.1	8.2	39.0	11.3	40.0	28.7	
H	151.037	QP	27.9	14.7	9.3	39.1	12.8	43.5	30.7	Floor noise
H	941.632	QP	26.1	22.0	14.9	38.1	24.9	46.0	21.1	Floor noise
V	30.786	QP	40.3	17.7	7.4	38.9	26.4	40.0	13.6	
V	59.394	QP	42.2	7.8	8.0	39.0	19.0	40.0	21.0	
V	71.275	QP	36.3	6.1	8.2	39.0	11.6	40.0	28.4	
V	73.007	QP	41.8	6.1	8.2	39.0	17.1	40.0	22.9	
V	151.079	QP	27.9	14.8	9.3	39.1	12.8	43.5	30.7	Floor noise
V	941.536	QP	26.1	22.0	14.9	38.1	24.9	46.0	21.1	Floor noise

* Other frequency noises omitted in this report were not seen or had enough margin (more than 20 dB).

CHART: WITH FACTOR

ANT TYPE: - 30 MHz: LOOP, 30 MHz - 200 MHz: BICONICAL, 200 MHz - 1000 MHz: LOGPERIODIC, 1000 MHz -: HORN
CALCULATION: RESULT = READING + ANT FACTOR + LOSS (CABLE + ATT) - GAIN(AMP)

UL Japan, Inc.

Ise EMC Lab.

4383-326 Asama-cho, Ise-shi, Mie-ken 516-0021 JAPAN

Telephone : +81 596 24 8999

Facsimile : +81 596 24 8124

Radiated Emission above 30 MHz (Spurious Emission)

Antenna TYPE 2 LUGGAGE 2

Report No. 12967063H
Test place Ise EMC Lab.
Semi Anechoic Chamber No.1
Date 07/24/2019
Temperature / Humidity 21 deg. C / 53 % RH
Engineer Shinya Watanabe
(Above 30 MHz)
Mode Tx 134.2 kHz, Antenna TYPE 2 LUGGAGE 2

Pola. [H/V]	Frequency [MHz]	Detector	Reading [dBuV]	Ant.Fac. [dB/m]	Loss [dB]	Gain [dB]	Result [dBuV/m]	Limit [dBuV/m]	Margin [dB]	Remark
H	30.679	QP	29.2	17.7	7.4	38.9	15.3	40.0	24.7	
H	44.976	QP	27.8	12.5	7.7	38.9	9.0	40.0	31.0	Floor noise
H	47.225	QP	28.0	11.6	7.7	38.9	8.4	40.0	31.6	Floor noise
H	66.516	QP	35.4	6.6	8.1	39.0	11.0	40.0	29.0	
H	73.014	QP	32.9	6.1	8.2	39.0	8.2	40.0	31.8	
H	940.776	QP	26.2	22.1	14.9	38.1	25.0	46.0	21.0	
V	30.790	QP	40.9	17.7	7.4	38.9	27.0	40.0	13.0	
V	45.020	QP	34.1	12.4	7.7	38.9	15.3	40.0	24.7	
V	47.225	QP	35.0	11.6	7.7	38.9	15.4	40.0	24.6	
V	66.516	QP	37.9	6.6	8.1	39.0	13.5	40.0	26.5	
V	73.014	QP	38.5	6.1	8.2	39.0	13.8	40.0	26.2	
V	941.334	QP	26.2	22.0	14.9	38.1	25.0	46.0	21.0	Floor noise

* Other frequency noises omitted in this report were not seen or had enough margin (more than 20 dB).

CHART: WITH FACTOR

ANT TYPE: - 30 MHz: LOOP, 30 MHz - 200 MHz: BICONICAL, 200 MHz - 1000 MHz: LOGPERIODIC, 1000 MHz -: HORN
CALCULATION: RESULT = READING + ANT FACTOR + LOSS (CABLE + ATT) - GAIN(AMP)

UL Japan, Inc.

Ise EMC Lab.

4383-326 Asama-cho, Ise-shi, Mie-ken 516-0021 JAPAN

Telephone : +81 596 24 8999

Facsimile : +81 596 24 8124

Radiated Emission above 30 MHz (Spurious Emission)
Antenna TYPE 1 (No.1) + TYPE 1 (No.2)

Report No. 12967063H
Test place Ise EMC Lab.
Semi Anechoic Chamber No.1
Date 07/24/2019
Temperature / Humidity 21 deg. C / 53 % RH
Engineer Shinya Watanabe
(Above 30 MHz)
Mode Tx 134.2 kHz, Antenna TYPE 1 (No.1) + TYPE 1 (No.2)

Pola. [H/V]	Frequency [MHz]	Detector	Reading [dBuV]	Ant.Fac. [dB/m]	Loss [dB]	Gain [dB]	Result [dBuV/m]	Limit [dBuV/m]	Margin [dB]	Remark
H	30.677	QP	28.5	17.7	7.4	38.9	14.6	40.0	25.4	Floor noise
H	47.242	QP	28.1	11.6	7.7	38.9	8.5	40.0	31.6	Floor noise
H	61.778	QP	32.3	7.3	8.0	39.0	8.6	40.0	31.4	
H	68.898	QP	28.7	6.3	8.1	39.0	4.1	40.0	35.9	Floor noise
H	87.635	QP	27.9	7.3	8.4	39.1	4.6	40.0	35.4	Floor noise
H	941.837	QP	26.2	22.0	14.9	38.1	25.0	46.0	21.0	Floor noise
V	30.677	QP	37.8	17.7	7.4	38.9	23.9	40.0	16.1	
V	47.242	QP	34.8	11.6	7.7	38.9	15.2	40.0	24.9	
V	61.778	QP	36.8	7.3	8.0	39.0	13.1	40.0	26.9	
V	68.898	QP	33.7	6.3	8.1	39.0	9.1	40.0	30.9	
V	87.635	QP	35.0	7.3	8.4	39.1	11.7	40.0	28.3	
V	941.837	QP	26.2	22.0	14.9	38.1	25.0	46.0	21.0	Floor noise

* Other frequency noises omitted in this report were not seen or had enough margin (more than 20 dB).

CHART: WITH FACTOR

ANT TYPE: - 30 MHz: LOOP, 30 MHz - 200 MHz: BICONICAL, 200 MHz - 1000 MHz: LOGPERIODIC, 1000 MHz -: HORN
CALCULATION: RESULT = READING + ANT FACTOR + LOSS (CABLE + ATT) - GAIN(AMP)

UL Japan, Inc.

Ise EMC Lab.

4383-326 Asama-cho, Ise-shi, Mie-ken 516-0021 JAPAN

Telephone : +81 596 24 8999

Facsimile : +81 596 24 8124

Radiated Emission Plot data, Worst case

Report No.	12967063H	
Test place	Ise EMC Lab.	
Semi Anechoic Chamber	No.1	No.1
Date	07/24/2019	07/24/2019
Temperature / Humidity	21 deg. C / 53 % RH	22 deg. C / 60 % RH
Engineer	Shinya Watanabe	Junya Okuno
	(Above 30 MHz)	(Below 30 MHz)
Mode	Tx 134.2 kHz, Antenna TYPE 2 LUGGAGE 2	

(below 30MHz)

Limit : FCC15.209(a), 9-90kHz:PK, 110-490kHz:PK, other:QP

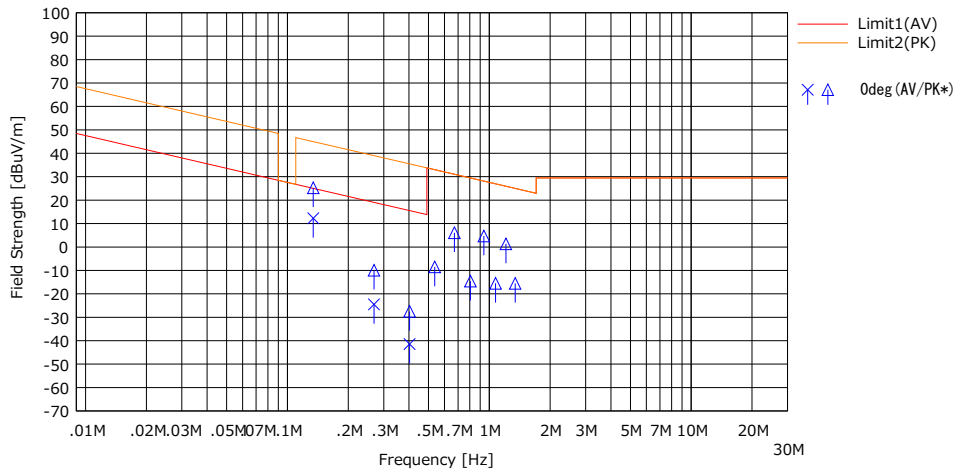

* Data above 490 kHz were measured using a QP detector.

(above 30MHz)

Limit : FCC15.209 3 m, below 1 GHz:QP, above 1 GHz:AV/PK

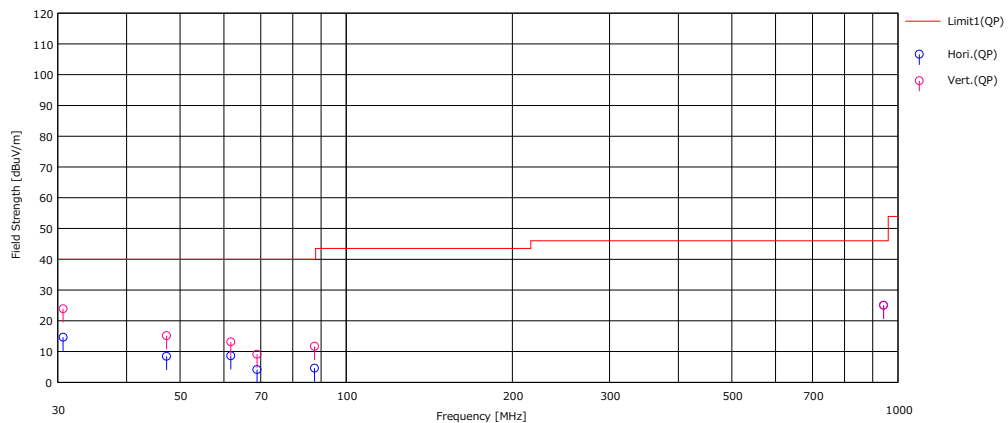

*These plots data contains sufficient number to show the trend of characteristic features for EUT.

Duty Cycle
Antenna TYPE 2 LUGGAGE 2

Report No. 12967063H
Test place Ise EMC Lab. No.1 shielded room
Date 07/25/2019
Temperature/ Humidity 23 deg. C / 63 % RH
Engineer Shinya Watanabe
Mode Tx 134.2 kHz, Antenna TYPE 2 LUGGAGE 2

(Total)

ON time [ms]	Cycle [ms]	Duty (On time/Cycle)	Duty [dB]
58.0	100.0	0.580	-4.73

ON time[ms] = 7.9 + 7.9 + 42.2 = 58.0

Duty = 20log₁₀(ON time/Cycle)

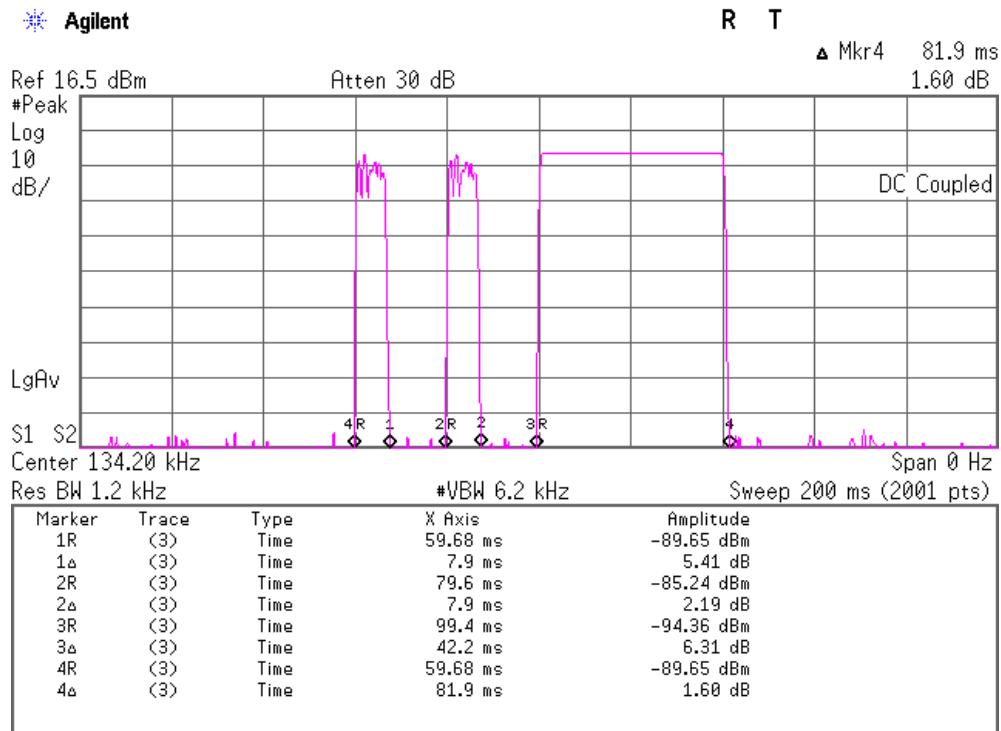

*This test result is the sequence pattern of Antenna (type 2) No. 4 in “Theory of Operation_Timing of transmission”. The worst-case Duty (as described above) was applied instead of the actual specification (Mass Products), for making continuous transmission for testing.

Actual specification: ONtime[ms]= (6 msec + 44.4 msec (74 * 0.6)) = 50.6msec

-26 dB Bandwidth / 99 % Occupied Bandwidth

Antenna TYPE 1

Report No. 12967063H
 Test place Ise EMC Lab. No.1 shielded room
 Date 07/25/2019
 Temperature/ Humidity 23 deg. C / 63 % RH
 Engineer Shinya Watanabe
 Mode Tx 134.2 kHz, Antenna TYPE 1

-26 dB Bandwidth [kHz]	99 % Occupied Bandwidth [kHz]
30.811	38.9795

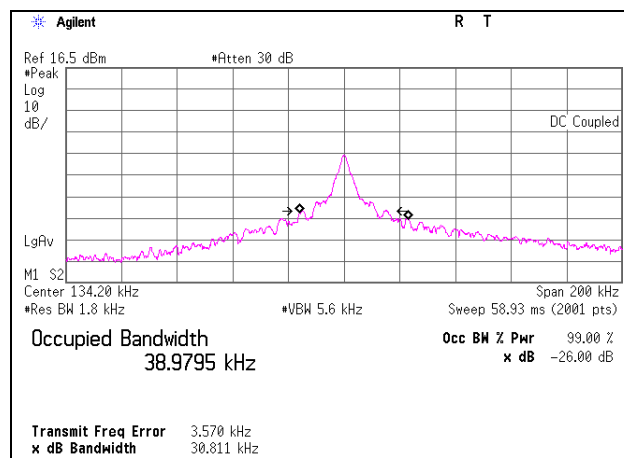

UL Japan, Inc.

Ise EMC Lab.

4383-326 Asama-cho, Ise-shi, Mie-ken 516-0021 JAPAN

Telephone : +81 596 24 8999

Facsimile : +81 596 24 8124

-26 dB Bandwidth / 99 % Occupied Bandwidth
 Antenna TYPE 2 INSIDE 1

Report No. 12967063H
 Test place Ise EMC Lab. No.1 shielded room
 Date 07/25/2019
 Temperature/ Humidity 23 deg. C / 63 % RH
 Engineer Shinya Watanabe
 Mode Tx 134.2 kHz, Antenna TYPE 2 INSIDE 1

-26 dB Bandwidth [kHz]	99 % Occupied Bandwidth [kHz]
26.546	34.3653

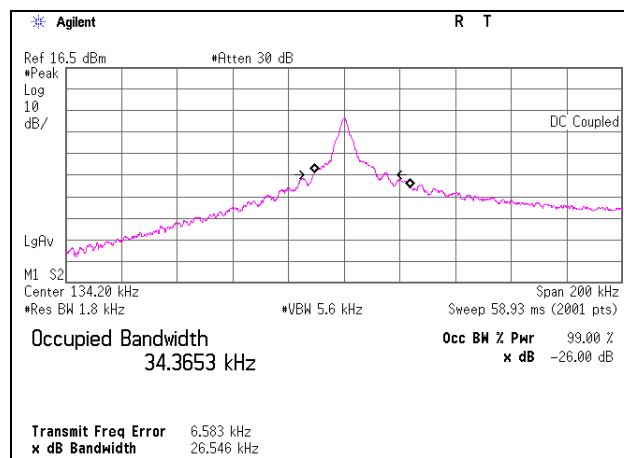

-26 dB Bandwidth / 99 % Occupied Bandwidth
 Antenna TYPE 2 LUGGAGE 2

Report No. 12967063H
 Test place Ise EMC Lab. No.1 shielded room
 Date 07/25/2019
 Temperature/ Humidity 23 deg. C / 63 % RH
 Engineer Shinya Watanabe
 Mode Tx 134.2 kHz, Antenna TYPE 2 LUGGAGE 2

-26 dB Bandwidth [kHz]	99 % Occupied Bandwidth [kHz]
21.521	21.6926

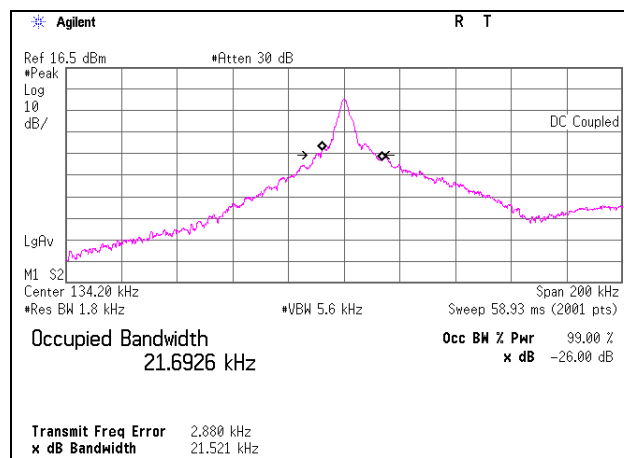

-26 dB Bandwidth / 99 % Occupied Bandwidth
 Antenna TYPE 1 (No.1) + TYPE 1 (No.2)

Report No. 12967063H
 Test place Ise EMC Lab. No.1 shielded room
 Date 07/25/2019
 Temperature/ Humidity 23 deg. C / 63 % RH
 Engineer Shinya Watanabe
 Mode Tx 134.2 kHz, Antenna TYPE 1 (No.1) + TYPE 1 (No.2)

-26 dB Bandwidth [kHz]	99 % Occupied Bandwidth [kHz]
26.822	34.2746

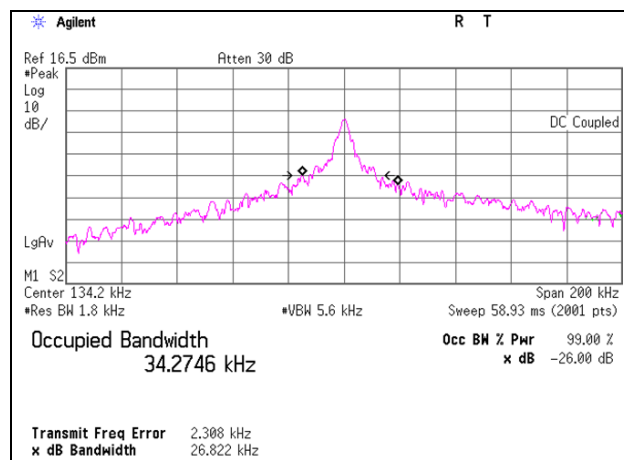

APPENDIX 2: Test instruments

Test Instruments

Test item	LIMS ID	Description	Manufacturer	Model	Serial	Last Calibration Date	Calibration Due Date	Cal Int
RE	141902	Spectrum Analyzer	AGILENT	E4440A	MY46187105	10/04/2018	10/31/2019	12
RE	141264	Logperiodic Antenna(200-1000MHz)	Schwarzbeck	VUSLP9111B	911B-189	03/21/2019	03/30/2020	12
RE	141198	Biconical Antenna	Schwarzbeck	BBA9106	2513	04/12/2019	04/30/2020	12
RE	141213	Attenuator(6dB)	Weinschel Corp	2	BK7971	11/05/2018	11/30/2019	12
RE	141585	Pre Amplifier	MITEQ	MLA-10K01-B01-35	1237616	02/08/2019	02/29/2020	12
RE	141350	Coaxial Cable	Suhner/storm/Agilent/TSJ	-	-	06/27/2019	06/30/2020	12
RE	141530	Digital Tester	Fluke Corporation	FLUKE 26-3	78030621	08/21/2018	08/31/2019	12
RE	141998	AC1_Semi Anechoic Chamber(NSA)	TDK	Semi Anechoic Chamber 10m	DA-06881	06/18/2018	06/30/2020	24
RE	141566	Thermo-Hygrometer	CUSTOM	CTH-201	A08Q26	01/11/2019	01/31/2020	12
RE	141950	EMI Test Receiver	Rohde & Schwarz	ESU26	100412	06/27/2019	06/30/2020	12
RE	141152	EMI measurement program	TSJ	TEPTO-DV	-	-	-	-
RE	142226	Measure	KOMELON	KMC-36	-	-	-	-
RE	141254	Loop Antenna	Rohde & Schwarz	HFH2-Z2	100017	10/11/2018	10/31/2019	12
RE	141582	Pre Amplifier	SONOMA INSTRUMENT	310	260834	02/08/2019	02/29/2020	12
RE	141413	Coaxial Cable	UL Japan	-	-	06/07/2019	06/30/2020	12
RE	178648	EMI measurement program	TSJ	TEPTO-DV	-	-	-	-
RE	141215	Coaxial Cable	Fujikura/Suhner/TSJ	5D-2W/3D-2W/RG400u/RFM-E421(SW)	-/01068 (Switcher)	06/27/2019	06/30/2020	12

*Hyphens for Last Calibration Date, Calibration Due Date and Cal Int (month) are instruments that Calibration is not required (e.g. software), or instruments checked in advance before use.

The expiration date of the calibration is the end of the expired month.

All equipment is calibrated with valid calibrations. Each measurement data is traceable to the national or international standards.

As for some calibrations performed after the tested dates, those test equipment have been controlled by means of an unbroken chains of calibrations.

Test item:

RE: Spurious emission

UL Japan, Inc.

Ise EMC Lab.

4383-326 Asama-cho, Ise-shi, Mie-ken 516-0021 JAPAN

Telephone : +81 596 24 8999

Facsimile : +81 596 24 8124