

User Manual

General introduction

LoRa SX-1276 1W module is a small-sized Sub 1GHz LoRa™ SMD wireless module designed by Chengdu Ebyte, based on the original imported RF chip SX1278/SX1276 from SEMTECH, supporting LoRa Spread spectrum technology, which brings longer transmission distance and has the advantages of concentrated power density and strong anti-interference.

The 30dBm module with PA(power amplifier) and low-noise amplifier enhanced the communication stability and communication distance; The 20dBm module integrated the industrial crystal oscillator, accuracy is less than 10ppm, with stable batch production, and widely used for utilities, IOT transformation and smart home,

The related RF parameters can get through the domestic and overseas certification, such as FCC, CE, RoHs etc., satisfying export demand.

Model No.	RF IC	Operating Frequency	Transmitting Power	Communication distance	Packaging	Antenna type
		MHz	dBm	km		
LoRa SX-1276 1W module	SX1276	902~928	30	10.0	SMD	Stamp hole /IPEX

LoRa SX-1276 1W module series module is a hardware platform. Without any program, users need to conduct the secondary development.

Contents

GENERAL INTRODUCTION	1
1. TECHNICAL PARAMETERS	3
1.1 GENERAL PARAMETERS.....	3
1.2 ELECTRICAL PARAMETERS	3
1.2.1 Transmitting current.....	3
1.2.2 Receiving current.....	3
1.2.3 Turn-off current.....	3
1.2.4 Supply voltage.....	3
1.2.5 Communication level.....	4
1.3 RF PARAMETERS	4
1.3.1 Transmitting Power.....	4
1.3.2 Receiving sensitivity.....	4
1.3.3 Recommended Frequency.....	4
1.4 TESTED DISTANCE	5
2. PIN DEFINITION	5
3.USAGE	6
4. REMARK	6
5. PRODUCTION GUIDANCE	7
5.1 REFLOW TEMPERATURE.....	7
5.2 REFLOW GRAPH.....	7
6. FAQ	7
6.1 THE COMMUNICATION DISTANCE IS TOO CLOSE	7
6.2 THE MODULE CAN BE DAMAGED EASILY	8
7. IMPORTANT STATEMENT	8
8.ABOUT US	9

1. Technical parameters

1.1 General parameters

Model No.	IC	Size	Net WT	Operating temp.	Operating humidity	Storage temp.
LoRa SX-1276 1W module	SX1276	25.0*40.0 mm	5.2±0.1g	-40 ~ 85°C	10% ~ 90%	-40 ~ 125°C

1.2 Electrical parameters

1.2.1 Transmitting current

Model No.	Min	Typ	Max	Unit	Remark
LoRa SX-1276 1W module	570.4	620.0	682.0	mA	<ul style="list-style-type: none"> When designing current supply circuit, 30% margin is recommended to be remained so as to ensure long-term stable operation of the whole module; The current at the instant of transmitting may be high, but the total energy consumed may be lower due to very short transmitting time; When using external antenna, the impedance matching degree at different frequency points between antenna and module may affect the transmitting current value at different levels.

1.2.2 Receiving current

Model No.	Min	Typ	Max	Unit	Remark
LoRa SX-1276 1W module	21.2	23.0	25.3	mA	<ul style="list-style-type: none"> The current consumed when the RF chip is only working at receiving mode is called as receiving current, the tested receiving current may be higher for some RF chips with communication protocol or the developers have loaded their own protocol to the whole module. The current at pure receiving mode will be mA level, the users have to realize μA level receiving current through firmware development.

1.2.3 Turn-off current

Model No.	Min	Typ	Max	Unit	Remark
LoRa SX-1276 1W module	1.5	3.0	4.5	μ A	<ul style="list-style-type: none"> The turn-off current means the current consumed when CPU, RAM, Clock and some registers remain operating while SoC is at very low power consumption status. The turn-off current is always lower than the current consumed when the power supply source of the whole module is at no-load status.

1.2.4 Supply voltage

Model No.	Min	Typ	Max	Unit	Remark
-----------	-----	-----	-----	------	--------

LoRa SX-1276 1W module	3.3	3.5	5.5	V DC	<ul style="list-style-type: none"> • If the voltage is at maximum value for long time, the module may be damaged; • The power supply pin has certain surge-resistance ability, but the potential pulse higher than the maximum power supply voltage; • The power supply voltage is recommended to be higher than 3.0V, if the voltage is lower than 3.0V, the RF parameters will be affected at different degrees.
------------------------	-----	-----	-----	------	---

1.2.5 Communication level

Model No.	Min	Typ	Max	Unit	Remark
LoRa SX-1276 1W module	1.8	3.3	3.6	V DC	<ul style="list-style-type: none"> • If the communication level is higher than the allowed maximum value, the module may be damaged; • Although the communication level can be switched with various methods, the power consumption of the whole module will be affected at great degree.

1.3 RF parameters

1.3.1 Transmitting Power

Model No.	Min	Typ	Max	Unit	Remark
LoRa SX-1276 1W module	29.6	30.0	30.5	dBm	<ul style="list-style-type: none"> • Due to the error of the materials, each LRC component has $\pm 0.1\%$ error, so error accumulation will occur since multiple LRC components are used in the whole RF circuit, and the transmitting currents will be different at different modules; • The power consumption can be lowered by lowering the transmitting power, but the efficiency of the internal PA will be decreased by lowering transmitting power due to various reasons; • The transmitting power will be lowered by lowering the power supply voltage.

1.3.2 Receiving sensitivity

Model No.	Min	Typ	Max	Unit	Remark
LoRa SX-1276 1W module	-147.2	-148.0	-149.2	dBm	<ul style="list-style-type: none"> • The current sensitivity is tested under the Coding rate of 4/5 and spread spectrum factor of 12 • Due to the error of the materials, each LRC component has $\pm 0.1\%$ error, so error accumulation will occur since multiple LRC components are used in the whole RF circuit, and the transmitting currents will be different at different modules; • The receiving sensitivity will be reduced and range will be shortened while increasing the air data rate.

1.3.3 Recommended Frequency

Model No	Min	Typ	Max	Unit	Remark
----------	-----	-----	-----	------	--------

LoRa SX-1276 1W module	900.0	915.0	931.0	MHz	<ul style="list-style-type: none"> It ensures that the performance of the module can reach the standard if it works in recommended operating frequency. It is recommended to avoid the crowded frequencies, such as 433.0MHz, 868.0MHz, 915MHz and other integer frequencies.
------------------------	-------	-------	-------	-----	---

1.4 Tested distance

Model No	Min	Typ	Max	Unit	Remark
LoRa SX-1276 1W module	9000	10000	11000	m	<ul style="list-style-type: none"> The external antenna used is of 5dBi gain and vertical polarization; The interval between each data packet is 2s, sending 100 packets with 30 bytes in each packet, the range at data lose rate of lower than 5% is valid range; In order to obtain meaningful and reproduceable results, we conducted the tests under in clear weather with little electromagnetic interference at suburb areas; Distance may be shorter with interference or obstacles.

2. Pin definition

2.1.2 LoRa SX-1276 1W module

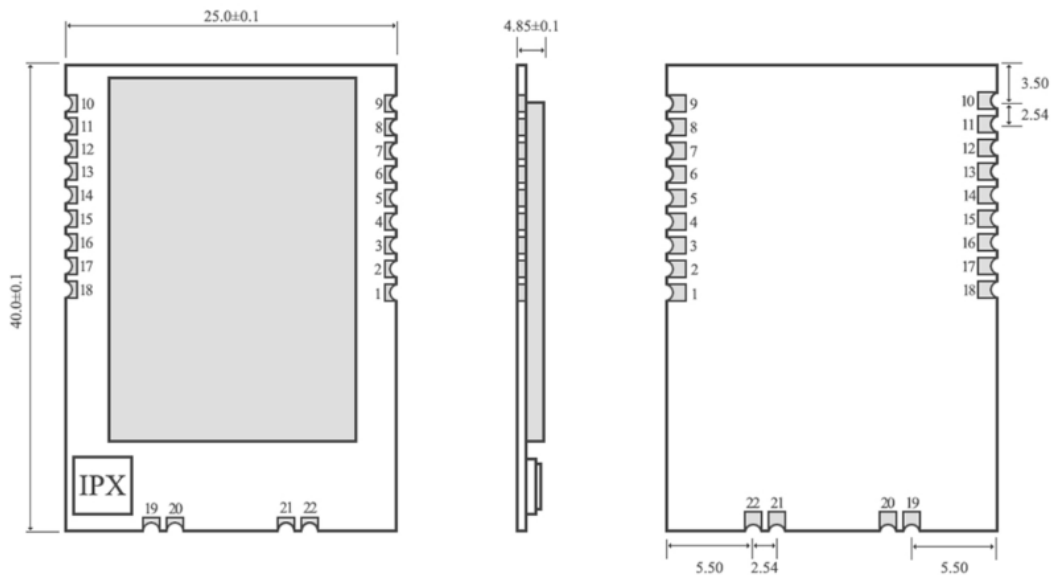

Pin No.	Name	Direction	Usage
1	GND		Ground electrode, connected to the power reference ground.
2	DIO5	Input/Output	Configurable IO port (Please find more on SX127X datasheet)
3	DIO4	Input/Output	Configurable IO port (Please find more on SX127X datasheet)
4	DIO3	Input/Output	Configurable IO port (Please find more on SX127X datasheet)
5	DIO2	Input/Output	Configurable IO port (Please find more on SX127X datasheet)
6	DIO1	Input/Output	Configurable IO port (Please find more on SX127X datasheet)

7	DIO0	Input/Output	Configurable IO port (Please find more on SX127X datasheet)
8	RST	Input	Reset
9	GND		Configurable IO port (Please find more on SX127X datasheet)
10	GND		Configurable IO port (Please find more on SX127X datasheet)
11	VCC		Power supply: 4.75~5.5V (Ceramic filter capacitor is advised to add)
12	SCK	Input	SPI clock
13	MISO	Output	Master output slave input
14	MOSI	Input	Master input slave output
15	NSS	Input	Chip select
16	TXEN	Input	Radio frequency switch control, make sure the TXEN pin is in high level, RXEN pin is in low level when transmitting.
17	RXEN	Input	Radio frequency switch control, Make sure the RXEN pin is in high level ,TXEN pin is in low level when receiving.
18	GND		Ground electrode, connected to the power reference ground
19	ANT		Antenna
20	GND		Ground electrode, connected to the power reference ground
21	GND		Ground electrode, connected to the power reference ground
★ Please find more on SX127X6 datasheet from SEMTECH ★			

3.Usage

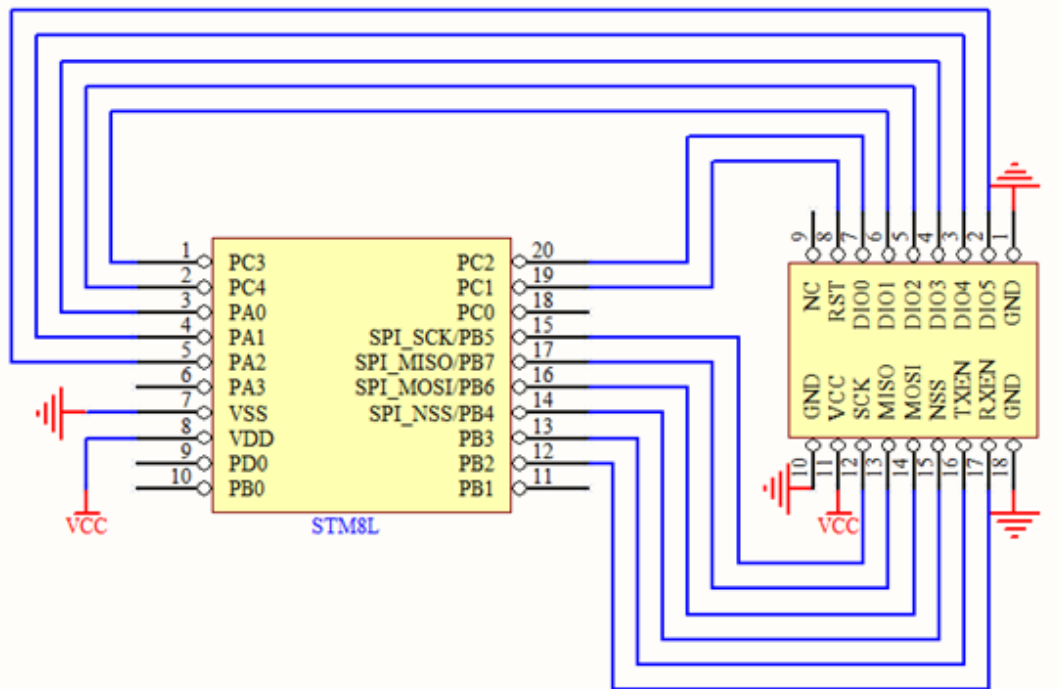

Brief introduction of connection between module and MCU (STM8L)

4. Remark

- DIO0, DIO1, DIO2, DIO3, DIO4, DIO5 is generally purpose I/O, can be configured into multiple function, please check SX1278/SX1276 manual for more details, floating is allowed.
- RST, TXEN, RXEN pin must be connected, in which RST control the reset of chip, TXEN, RXEN pin control RF switch.

- Make sure the grounding is good, with low power ripple, also should increase filter capacitor and as close as possible to the VCC and GND pins.
- SPI communication rate should not be set too high, usually around 1M
- Make sure TXEN pin is high level, RXEN pin is low level when transmitting; make sure RXEN pin is high level, TXEN pin is low level when receiving; make sure TXEN、RXEN pin is low level before turning off.
- The register configuration can be reinitialized to obtain higher stability when the chip is invalid.

5. Production Guidance

5.1 Reflow Temperature

Preheating zone: Maximum temperature rise is 2.5°C/s;

Insulation zone: temperature: 150~190°C, time: 60~90s, Maximum temperature rise is 2.5°C/s;

Recirculation zone: Maximum temperature is 235~245°C, Above 217°C, the time will be 40~80s;

Cooling zone: Maximum cooling is 4°C/s.

5.2 Reflow Graph

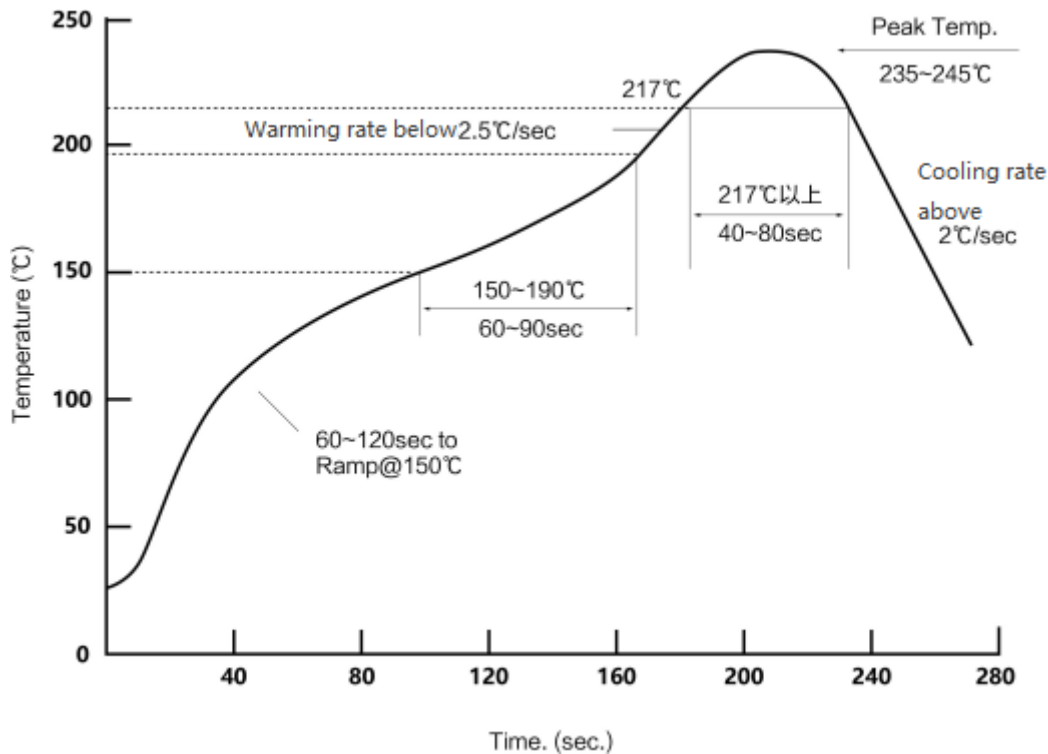

6. FAQ

6.1 The communication distance is too close

- When there' s straight Communication barrier, the communication distance will be reduced accordingly.
- Temperature, humidity and same frequency interference will increase the rate of communication packet loss.
- Ground absorption, reflected radio waves, and closing to ground will lead to poor test result.
- Sea water has a strong ability to absorb radio waves, so test near the sea is not recommended .
- If antennas surrounded by metal items or placed in metal shell, the signal will be weakened badly.
- Power register is set wrongly or air data rate too high.(The higher the air data rate, the closer the distance.
- In room temperature, the power voltage will be less than 2.5V. The lower the the power voltage, the smaller the power.
- The antenna is unmatched to the module or the quality of antenna.

6.2 The module can be damaged easily

- Please check the power supply, which should be 1.8v-3.8v. If the value exceeds that, the module will be damaged.
- Please check the stability of power supply. The voltage cannot be in fluctuations frequently.
- Please ensure all the installation operations are anti-static.
- Please ensure the humidity in the procedure of installation and operation should not be too high because some electrical parts are humidity sensitive device.
- Please do not use it in a too high or too low temperature environment if there' s no special requirement.

7. Important statement

- Ebyte reserves the rights of final interpretation and revision for all the involved contents in this manual.
- With the continuous improvement of hardware and software, this manual may subject to change without notice. Please refer to the latest version.
- Users can follow the product news on our official website so as to gain the latest information.

FCC Caution

- This device complies with part 15 of the FCC Rules. Operation is subject to the following two conditions: (1) This device may not cause harmful interference, and (2) this device must accept any interference received, including interference that may cause undesired operation.
- Any Changes or modifications not expressly approved by the party responsible for compliance could void the user's authority to operate the equipment.
- Note: This equipment has been tested and found to comply with the limits for a Class B digital device, pursuant to part 15 of the FCC Rules. These limits are designed to provide reasonable protection against harmful interference in a residential installation. This equipment generates uses and can radiate radio frequency energy and, if not installed and used in accordance with the instructions, may cause harmful interference to radio communications. However, there is no guarantee that interference will not occur in a particular installation. If this equipment does cause harmful interference to radio or television reception, which can be determined by turning the equipment off and on, the user is encouraged to try to correct the interference by one or more of the following measures:
 - Reorient or relocate the receiving antenna.
 - Increase the separation between the equipment and receiver.
 - Connect the equipment into an outlet on a circuit different from that to which the receiver is connected.
 - Consult the dealer or an experienced radio/TV technician for help.

Integration instructions for host product manufacturers according to KDB 996369 D03 OEM Manual v01

2.2 List of applicable FCC rules

CFR 47 FCC PART 15 SUBPART C has been investigated. It is applicable to the modular transmitter

2.3 Specific operational use conditions

This module is stand-alone modular. If the end product will involve the Multiple simultaneously transmitting condition or different operational conditions for a stand-alone modular transmitter in a host, host manufacturer have to consult with module man

2.4 Limited module procedures

Not applicable

2.5 Trace antenna designs

Not applicable

2.6 RF exposure considerations

This equipment complies with FCC radiation exposure limits set forth for an uncontrolled environment. This equipment should be installed and operated with minimum distance 20cm between the radiator & your body.

2.7 Antennas

This radio transmitter Y8E-VM-LORA has been approved by Federal Communications Commission to operate with the antenna types listed below, with the maximum permissible gain indicated. Antenna types not included in this list that have a gain greater than the maximum gain indicated for any type listed are strictly prohibited for use with this device.

Antenna No.	Operate frequency band	Antenna Type	Maximum antenna gain
Antenna 1	902-928MHz	External Antenna	1.5dBi

2.8 Label and compliance information

The final end product must be labeled in a visible area with the following" Contains FCC ID:Y8E-VM-LORA".

2.9 Information on test modes and additional testing requirements

Host manufacturer is strongly recommended to confirm compliance with FCC requirements for the transmitter when the module is installed in the host.

2.10 Additional testing, Part 15 Subpart B disclaimer

Host manufacturer is responsible for compliance of the host system with module installed with all other applicable requirements for the system such as Part 15 B.

8. About US

Technical support: support@cdebyte.com

Documents and RF Setting download link: www.cdebyte.com/en/



Tel: +86-28-61399028

Fax: 028-64146160

Web: www.cdebyte.com/en/

Address: Innovation Center D347, 4# XI-XIN Road, Chengdu, Sichuan, China