



FCC 47 CFR PART 15 SUBPART C

TEST REPORT

For

Applicant : CLC Hong Kong Limited

Address : 2209, Concordia Plaza, North Tower, No.1 Science Museum Road, Tsim Sha Tsui East, Kowloon, Hong Kong

Product Name : Mobile Phone

Model Name : Wicked, Z100 , Z101

Brand Name : plum

FCC ID : Y7WPLUMWICKED

Report No. : DPH120705F05

Date of Issue : July. 24, 2012

Issued by : Super Test Service Technology Co., Ltd.

Address : Room 506, Hongyu Commercial Building, Gushu 2nd Road, Baoan District, Shenzhen, China

Tel : 0755-61196328

Fax : 0755-61196328

The report consists 83 pages in total. It may be duplicated completely for legal use with the approval of the applicant. It should not be reproduced except in full, without the written approval of our laboratory. The client should not use it to claim product endorsement by STS. The test results in the report only apply to the tested sample. The test report shall be invalid without all the signatures of testing engineers, reviewer and approver.

TABLE OF CONTENTS

1. VERIFICATION OF CONFORMITY 3

2. GENERAL INFORMATION 4

2.1 Product Information 4

2.2 Objective 5

2.3 Test Standards and Results 5

2.4 Environmental Conditions 5

3. TEST FACILITY 6

3.1 Test Facility 6

3.2 General Test Procedures 6

3.3 FCC Part 15.205 Restricted Bands of Operations 7

4. TEST EQUIPMENT LIST 8

5. 47 CFR Part 15 C 15.247 Requirements 9

5.1 6dB Bandwidth 9

5.2 Peak Output Power 16

5.3 Conducted Spurious Emission 18

5.4 Band Edge 31

5.5 Power Spectral Density (PSD) 36

5.6 Conducted Emission 43

5.7 Radiated Emission 46

APPENDIX 1 71

PHOTOGRAPHS OF TEST SETUP 71

APPENDIX 2 74

PHOTOGRAPHS OF EUT 74

| Revision History | | |
|------------------|---------------|---------------------|
| Issue | Date | Reason for Revision |
| 1.0 | July 24, 2012 | First edition |
| | | |

1. VERIFICATION OF CONFORMITY

| | |
|----------------------------------|-------------------------------------------------------------------------------------------------------------------|
| Equipment Under Test: | Mobile Phone |
| Brand Name: | plum |
| Model Number: | Wicked |
| Series Model Name: | Z100, Z101 |
| Difference description: | The main board is the same, but the series models Z101 only support one SIM card. |
| FCC ID: | Y7WPLUMWICKED |
| Applicant: | CLC Hong Kong Limited |
| | 2209, Concordia Plaza, North Tower, No.1 Science Museum Road, Tsim Sha Tsui East, Kowloon, Hong Kong |
| Manufacturer: | CLC Technology Co. Ltd |
| | Room 303, Block 31, Longtang Industrial Zone, Longtang Community Minzhi Street, Bao'an District , Shenzhen, China |
| Technical Standards: | 47 CFR Part 15 Subpart C |
| File Number: | DPH120705F05 |
| Date of test: | July 07~ July 23, 2012 |
| Deviation: | None |
| Condition of Test Sample: | Normal |
| Test Result: | PASS |

The above equipment was tested by STS. For compliance with the requirements set forth in FCC rules and the Technical Standards mentioned above. This said equipment in the configuration described in this report shows the maximum emission levels emanating from equipment and the level of the immunity endurance of the equipment are within the compliance requirements.

The test results of this report relate only to the tested sample identified in this report.

Tested by (+ signature):

Approved by (+ signature):

Rex Luo

Joe Jia

Rex Luo
Test Engineer

Joe Jia
Manager

2. GENERAL INFORMATION

2.1 Product Information

| | |
|-----------------------|------------------------------------------------------------------------------------------------------------------------------------------------------------------------------------------------------------------------------------------------------------------------------------------------------------------|
| Description: | Mobile Phone |
| Brand Name: | plum |
| Model Name: | Wicked |
| Frequency Range: | IEEE 802.11b/g/n-20MHz mode: 2412MHz- 2462MHz IEEE 802.11n Standard-40 MHz Channel mode: 2422MHz- 2452MHz |
| Test Frequency: | IEEE 802.11b/g/n-20MHz mode: 2412MHz, 2437MHz, 2462MHz IEEE 802.11n Standard-40 MHz Channel mode: 2422MHz, 2437MHz, 2452MHz |
| Number of Channels: | IEEE 802.11b/g/n-20MHz mode: 11 Channels IEEE 802.11n Standard-40 MHz Channel mode: 7 Channels |
| Modulation Technique: | IEEE 802.11b mode: DSSS (1, 2, 5.5 and 11 Mbps) IEEE 802.11g mode: OFDM (6, 9, 12, 18, 24, 36, 48 and 54 Mbps) IEEE 802.11n Standard-20 MHz Channel mode: OFDM(6.5, 13, 19.5, 26, 39, 52, 58.5, 65.0Mbps) IEEE 802.11n Standard-40 MHz Channel mode: OFDM (13.5, 27, 40.5, 54, 81, 108, 121.5, 135Mbps) |
| Power Supply: | DC 5V by AC/DC adapter 100~240V 50/60Hz DC 3.7V by Lithium-ion Battery |
| Temperature Range: | -20°C ~ +50°C |

NOTE:

1. For more detailed features description about the EUT, please refer to User's Manual.

2.2 Objective

The objective of the report is to perform tests according to 47 CFR Part 15 Subpart C for the EUT FCC ID Certification:

| No. | Identity | Document Title |
|-----|---------------------------------|-------------------------|
| 1 | 47 CFR Part 15(10-1-09 Edition) | Radio Frequency Devices |

2.3 Test Standards and Results

Test items and the results are as bellow:

| No. | Section | Description | Result | Date of Test |
|-----|-------------------------------|-----------------------------|--------|--------------|
| 1 | 15.247(a)(2) | 6dB Bandwidth | PASS | 2012-07-21 |
| 2 | 15.247(b)(3) | Peak Output Power | PASS | 2012-07-21 |
| 3 | 15.247(d) | conducted spurious emission | PASS | 2012-07-21 |
| 4 | 15.247(d) | Band Edge | PASS | 2012-07-21 |
| 5 | 15.247(e) | Power Spectral Density | PASS | 2012-07-21 |
| 6 | 15.207 | Conducted Emission | PASS | 2012-07-13 |
| 7 | 15.247(d) 15.205 15.209 | Radiated Emission | PASS | 2012-07-13 |

Note: 1. The test result judgment is decided by the limit of measurement standard
2. The information of measurement uncertainty is available upon the customer's request.

2.4 Environmental Conditions

During the measurement the environmental conditions were within the listed ranges:

- Temperature: 15-35°C
- Humidity: 30-60 %
- Atmospheric pressure: 86-106 kPa

3. TEST FACILITY

3.1 Test Facility

| | |
|-----------------------|----------------------------------------------------------------------------------------------------------------------------------------------------------------------------------------------------------------------------------------------------------------------------------------------------------------------------------------------------------------------------------------------------------------------------------------------------------------------------------------------------------------------------------------------------------------------------------------------------------------------------------------------------------------------------------------------------------------------------------------------------------------------------------------------------------------------------------------------------------------|
| Test Site: | Most Technology Service Co., Ltd. |
| Location: | No.5, Nangshan 2nd Rd., North Hi-Tech Industrial park, Nanshan, Shenzhen, Guangdong, China |
| Description: | There is one 3m semi-anechoic an area test sites and two line conducted labs for final test. The Open Area Test Sites and the Line Conducted labs are constructed and calibrated to meet the FCC requirements in documents ANSI C63.4 and CISPR 16 requirements. The FCC Registration Number is 490827 . |
| Site Filing: | The site description is on file with the Federal Communications Commission, 7435 Oakland Mills Road, Columbia, MD 21046. |
| Instrument Tolerance: | All measuring equipment is in accord with ANSI C63.4 and CISPR 16 requirements that meet industry regulatory agency and accreditation agency requirement. |
| Ground Plane: | Two conductive reference ground planes were used during the Line Conducted Emission, one in vertical and the other in horizontal. The dimensions of these ground planes are as below. The vertical ground plane was placed distancing 40 cm to the rear of the wooden test table on where the EUT and the support equipment were placed during test. The horizontal ground plane projected 50 cm beyond the footprint of the EUT system and distanced 80 cm to the wooden test table. For Radiated Emission Test, one horizontal conductive ground plane extended at least 1m beyond the periphery of the EUT and the largest measuring antenna, and covered the entire area between the EUT and the antenna. It has no holes or gaps having longitudinal dimensions larger than one-tenth of a wavelength at the highest frequency of measurement up to 1GHz. |

3.2 General Test Procedures

Conducted Emissions

The EUT is placed on the turntable, which is 0.8 m above ground plane. According to the requirements in Section 13.1.4.1 of ANSI C63.4:2009, Conducted emissions from the EUT measured in the frequency range between 0.15 MHz and 30MHz using CISPR Quasi-peak and average detector modes.

Radiated Emissions

The EUT is placed on a turn table, which is 0.8 m above ground plane. The turntable shall rotate 360 degrees to determine the position of maximum emission level. EUT is set 3m away from the receiving antenna, which varied from 1m to 4m to find out the highest emission. And also, each emission was to be maximized by changing the polarization of receiving antenna both horizontal and vertical. In order to find out the maximum emissions, exploratory radiated emission measurements were made according to the requirements in Section 13.1.4.1 of ANSI C63.4:2009.

3.3 FCC Part 15.205 Restricted Bands of Operations

(a) Except as shown in paragraph (d) of this section, only spurious emissions are permitted in any of the frequency bands listed below:

| MHz | MHz | MHz | GHz |
|--------------------------|-----------------------|-----------------|------------------|
| 0.090 0.110 | 16.42 - 16.423 | 399.9 - 410 | 4.5 - 5.15 |
| ¹ 0.495 0.505 | 16.69475 - 16.69525 | 608 - 614 | 5.35 - 5.46 |
| 2.1735 2.1905 | 16.80425 - 16.80475 | 960 - 1240 | 7.25 - 7.75 |
| 4.125 - 4.128 | 25.5 - 25.67 | 1300 - 1427 | 8.025 - 8.5 |
| 4.17725 - 4.17775 | 37.5 - 38.25 | 1435 - 1626.5 | 9.0 - 9.2 |
| 4.20725 - 4.20775 | 73 - 74.6 | 1645.5 - 1646.5 | 9.3 - 9.5 |
| 6.215 - 6.218 | 74.8 - 75.2 | 1660 - 1710 | 10.6 - 12.7 |
| 6.26775 - 6.26825 | 108 - 121.94 | 1718.8 - 1722.2 | 13.25 - 13.4 |
| 6.31175 - 6.31225 | 123 - 138 | 2200 - 2300 | 14.47 - 14.5 |
| 8.291 - 8.294 | 149.9 - 150.05 | 2310 - 2390 | 15.35 - 16.2 |
| 8.362 8.366 | 156.52475 - 156.52525 | 2483.5 - 2500 | 17.7 - 21.4 |
| 8.37625 - 8.38675 | 156.7 - 156.9 | 2655 - 2900 | 22.01 - 23.12 |
| 8.41425 - 8.41475 | 162.0125 - 167.17 | 3260 - 3267 | 23.6 - 24.0 |
| 12.29 - 12.293 | 167.72 - 173.2 | 3332 - 3339 | 31.2 - 31.8 |
| 12.51975 - 12.52025 | 240 - 285 | 3345.8 - 3358 | 36.43 - 36.5 |
| 12.57675 - 12.57725 | 322 - 335.4 | 3600 - 4400 | (²) |
| 13.36 13.41 | | | |

¹ Until February 1, 1999, this restricted band shall be 0.490-0.510 MHz.

² Above 38.6

(b) Except as provided in paragraphs (d) and (e), the field strength of emissions appearing within these frequency bands shall not exceed the limits shown in Section 15.209. At frequencies equal to or less than 1000 MHz, compliance with the limits in Section 15.209 shall be demonstrated using measurement instrumentation employing a CISPR quasipeak detector. Above 1000 MHz, compliance with the emission limits in Section 15.209 shall be demonstrated based on the average value of the measured emissions. The provisions in Section 15.35 apply to these measurements.

4. TEST EQUIPMENT LIST

Instrumentation: The following list contains equipment used at MOST for testing. The equipment conforms to the CISPR 16-1/ANSI C63.2 Specifications for Electromagnetic Interference and Field Strength Instrumentation from 10 kHz to 1.0 GHz or above.

| No. | Equipment | Manufacturer | Model No. | S/N | Calibration due date |
|-----|-----------------------------------------|-------------------|----------------|------------|----------------------|
| 1 | Test Receiver | Rohde & Schwarz | ESCI | 100492 | 2013/4/21 |
| 2 | L.I.S.N. | Rohde & Schwarz | ENV216 | 100093 | 2013/4/21 |
| 3 | Coaxial Switch | Anritsu Corp | MP59B | 6200283933 | 2013/3/14 |
| 4 | Terminator | Hubersuhner | 50Ω | No.1 | 2013/3/14 |
| 5 | RF Cable | SchwarzBeck | N/A | No.1 | N/A |
| 6 | Test Receiver | Rohde & Schwarz | ESPI | 101202 | 2013/4/21 |
| 7 | Test Antenna – Horn | Schwarzbeck | BBHA 9120C | -- | 2013/3/14 |
| 8 | Test Antenna – Bi-Log | Schwarzbeck | VULB 9163 | -- | 2013/3/14 |
| 9 | Power Splitter | Weinschel | 1506A | NW521 | N/A |
| 10 | Spectrum Analyzer | Agilent | 4408B | MY41440460 | 2013/4/21 |
| 11 | Cable | Resenberger | N/A | NO.1 | N/A |
| 12 | Cable | SchwarzBeck | N/A | NO.2 | N/A |
| 13 | Cable | SchwarzBeck | N/A | NO.3 | N/A |
| 14 | Signal Generator | IFR | 2032 | 203002/100 | 2013/5/21 |
| 15 | EPM Series Power Meter | Agilent | E4418B | GB43318063 | 2013/5/21 |
| 16 | Universal Radio Communication Tester | ROHDE&SCHWARZ | CMU200 | 0304789 | 2013/4/21 |
| 17 | Telecommunication Antenna | European Antennas | PSA 75301R/170 | 0304213 | 2012/03/14 |
| 18 | DC Power Supply | Good Will | GPS-3030DD | EF920938 | 2013/4/21 |
| 19 | Full-Anechoic Chamber | Albatross | 9m*6m*6m | (n.a.) | 2013/4/15 |

NOTE: Equipments listed above have been calibrated and are in the period of validation.

5. 47 CFR Part 15 C 15.247 Requirements

5.1 6dB Bandwidth

5.1.1 Definition

Systems using digital modulation techniques may operate in the 902–928 MHz, 2400–2483.5 MHz, and 5725–5850 MHz bands. The minimum 6 dB bandwidth shall be at least 500 kHz.

5.1.2 Test Description

The EUT is powered by the Battery, is coupled to the Spectrum Analyzer (SA) through the Attenuator/DC Block. The path loss as the factor is calibrated to correct the reading. During the measurement, the EUT is activated and is set to operate at maximum power. The RF load attached to the EUT antenna terminal is 50Ohm.

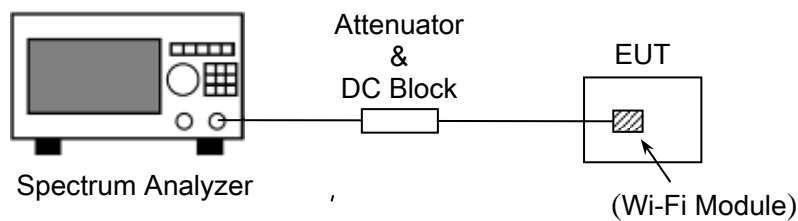

Figure 1: RF Test Setup

5.1.3 Test Result

The lowest, middle and highest channels are selected to perform testing to record the 6 dB bandwidth of the Module.

802.11b Test Mode

| Channel | Frequency (MHz) | 6 dB Bandwidth (MHz) | Limits (kHz) | Result |
|---------|-----------------|----------------------|--------------|--------|
| 1 | 2412 | 9.50 | ≥500 | PASS |
| 6 | 2437 | 10.00 | ≥500 | PASS |
| 11 | 2462 | 9.70 | ≥500 | PASS |

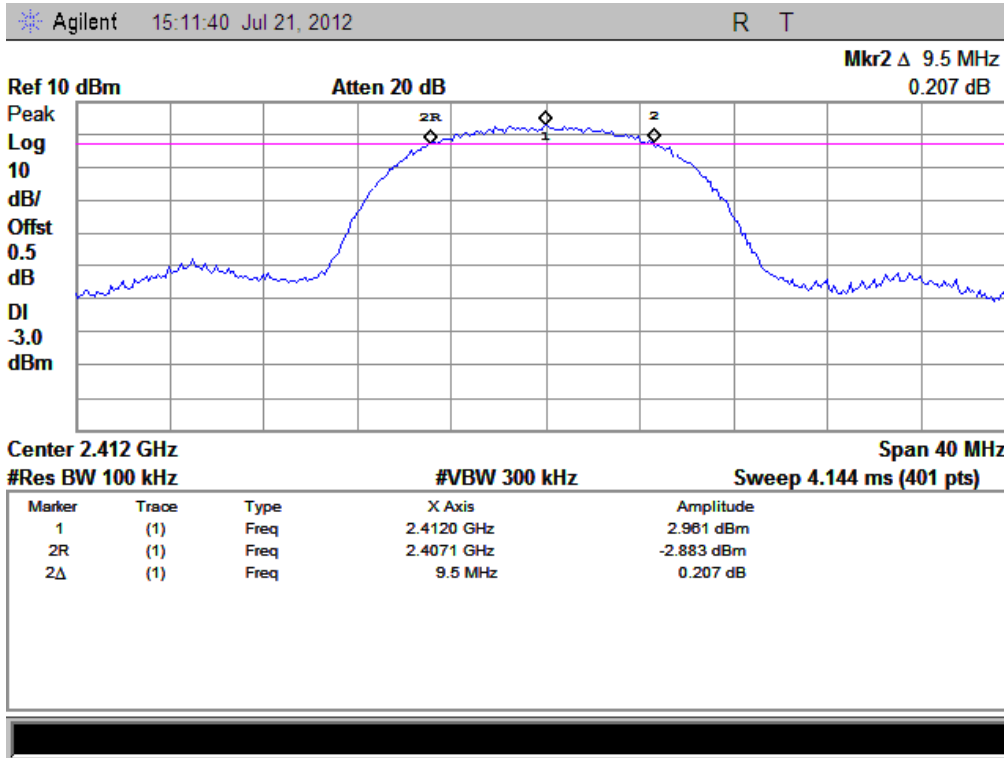

(CH Low)

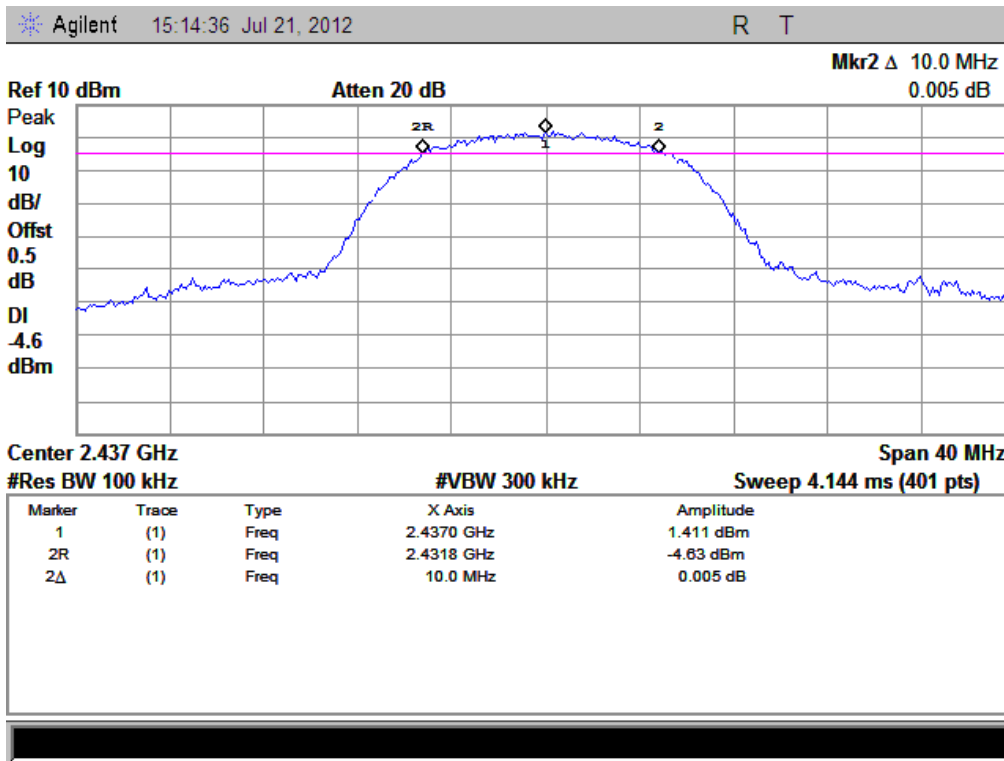

(CH Mid)

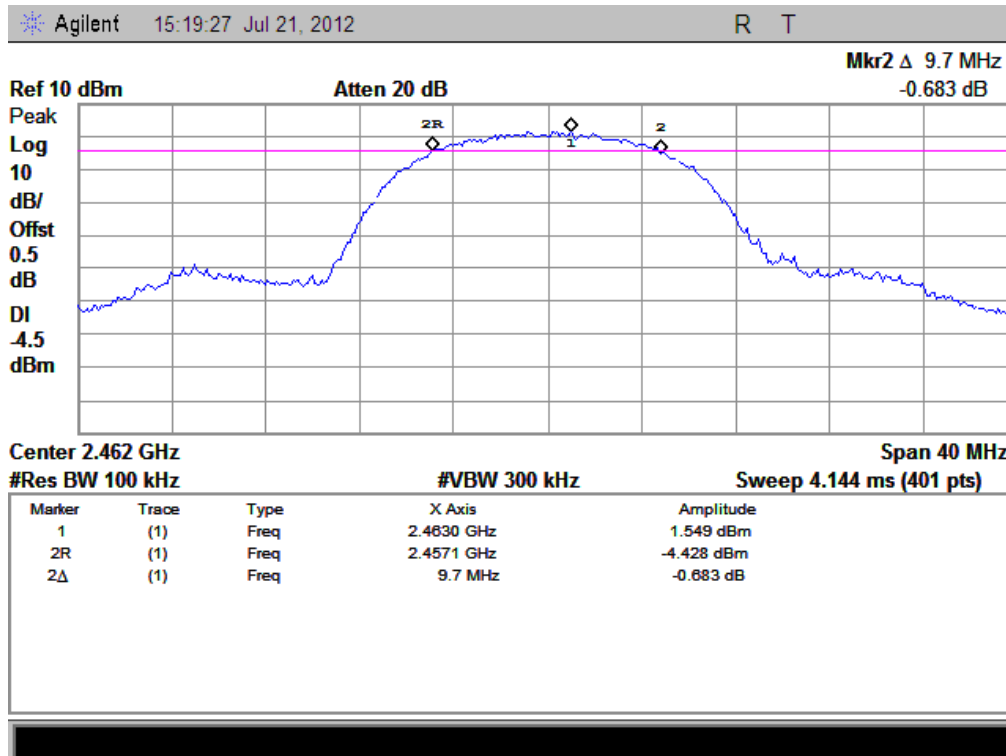

(CH High)

802.11g Test Mode

| Channel | Frequency (MHz) | 6 dB Bandwidth (MHz) | Limits (kHz) | Result |
|---------|-----------------|----------------------|--------------|--------|
| 1 | 2412 | 16.60 | ≥500 | PASS |
| 6 | 2437 | 16.60 | ≥500 | PASS |
| 11 | 2462 | 16.60 | ≥500 | PASS |

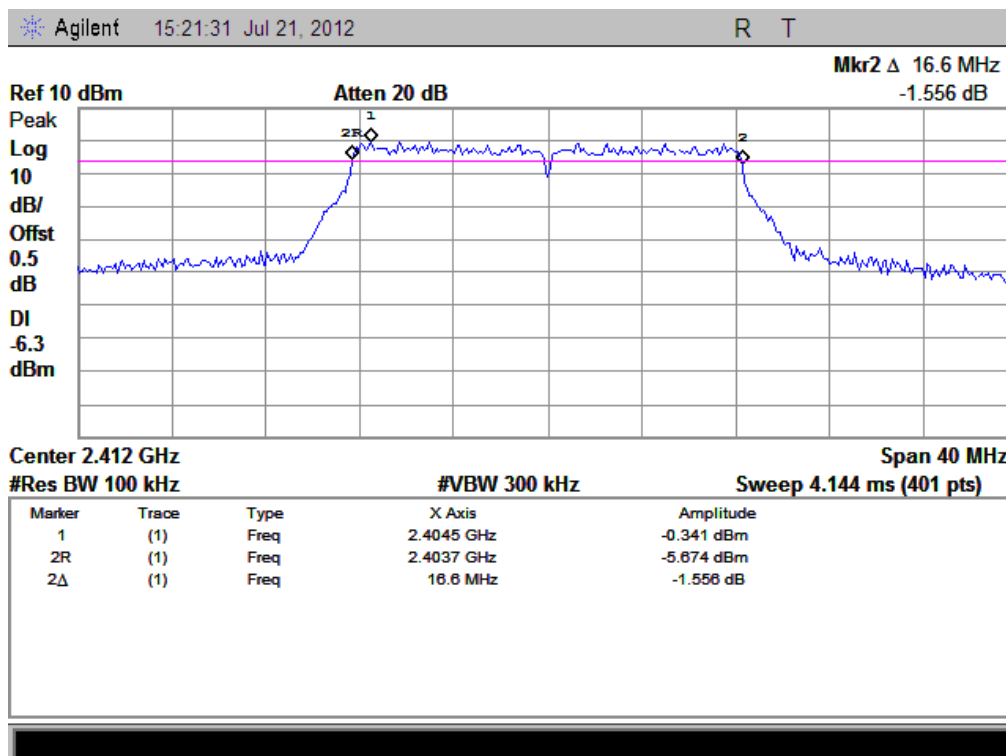

(CH Low)

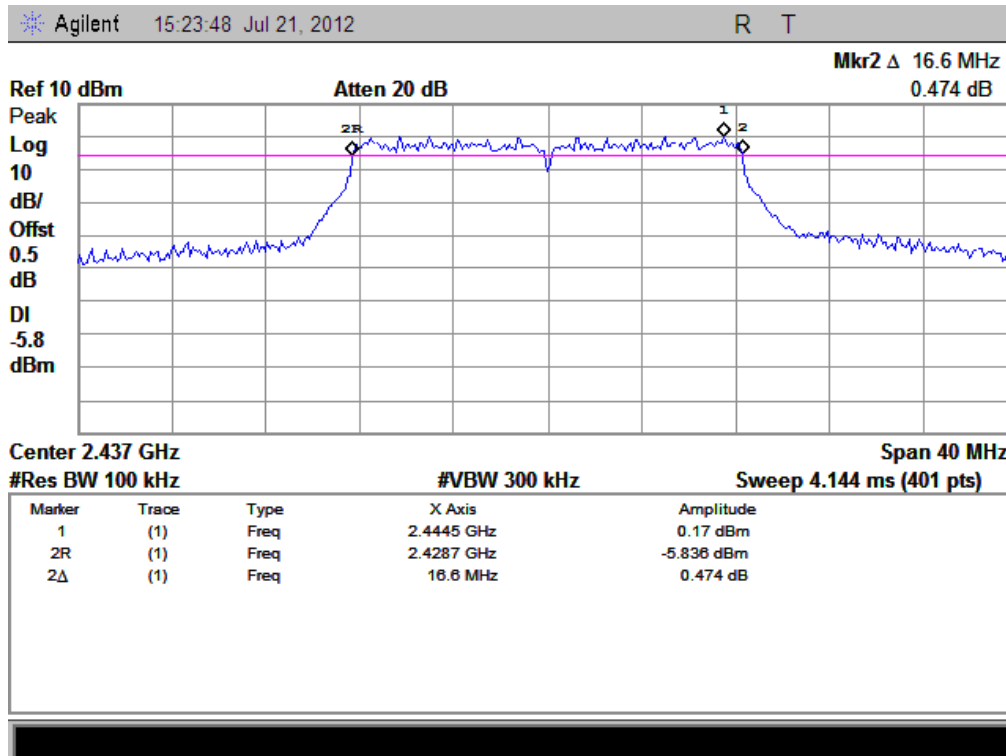

(CH Mid)

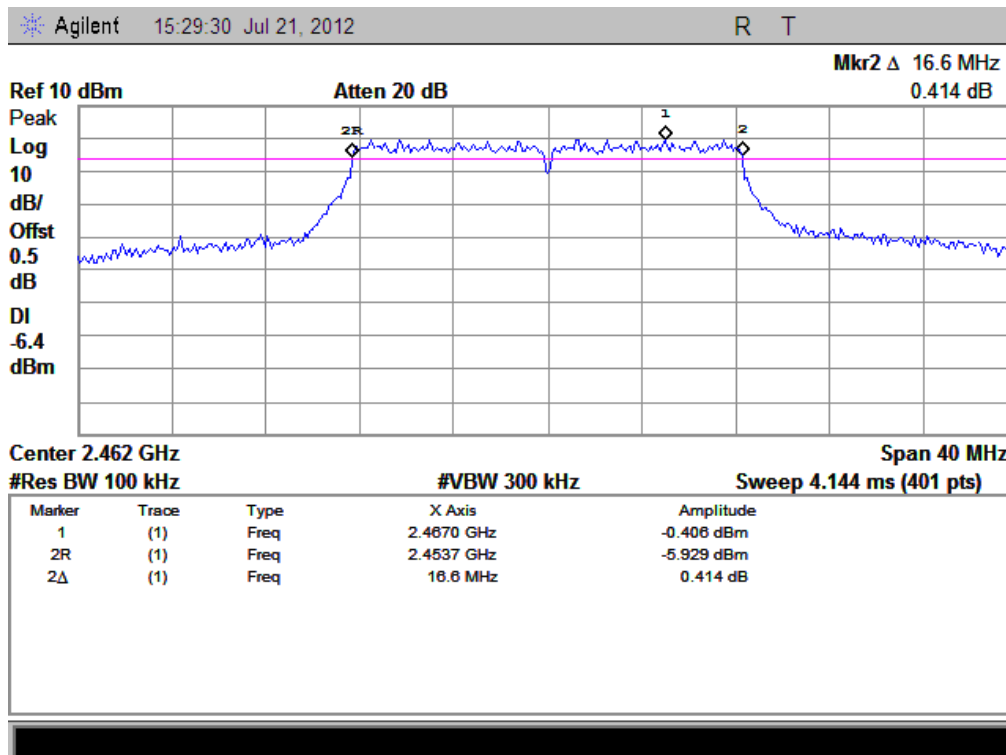

(CH High)

802.11n-20MHz Test Mode

| Channel | Frequency (MHz) | 6 dB Bandwidth (MHz) | Limits (kHz) | Result |
|---------|-----------------|----------------------|--------------|--------|
| 1 | 2412 | 18.00 | ≥500 | PASS |
| 6 | 2437 | 18.00 | ≥500 | PASS |
| 11 | 2462 | 17.80 | ≥500 | PASS |

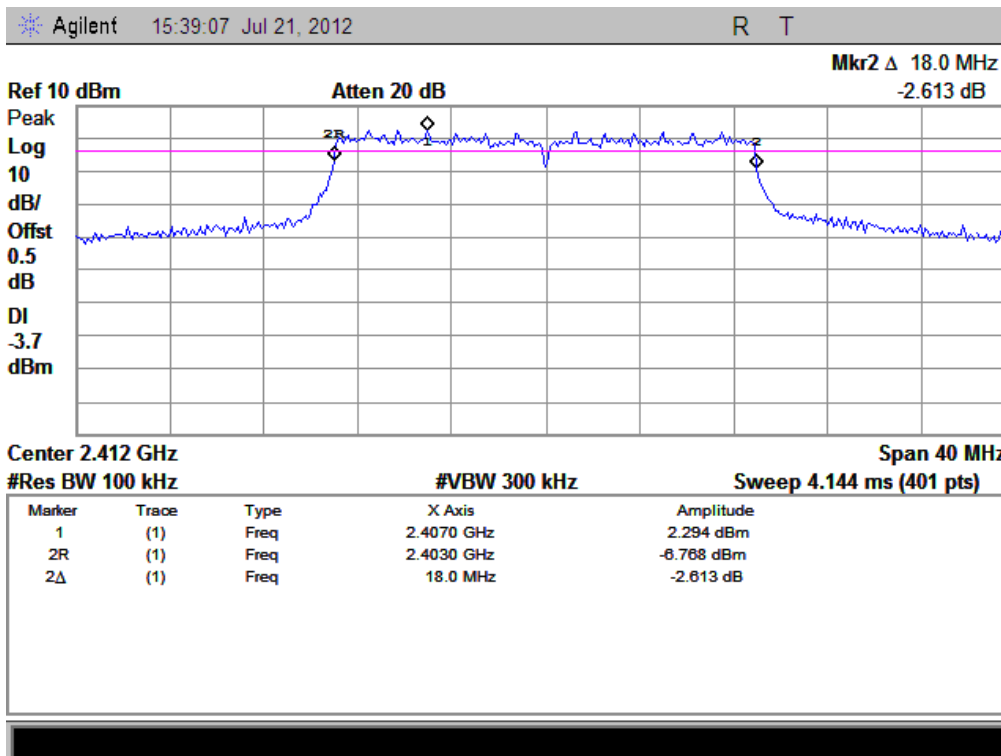

(CH Low)

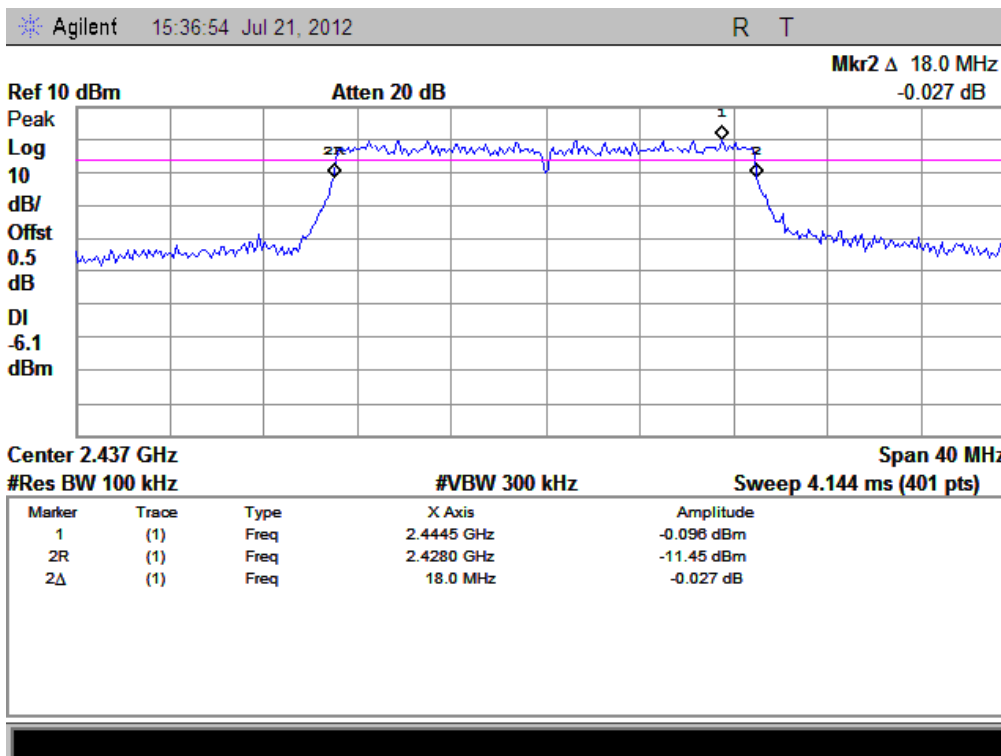

(CH Mid)

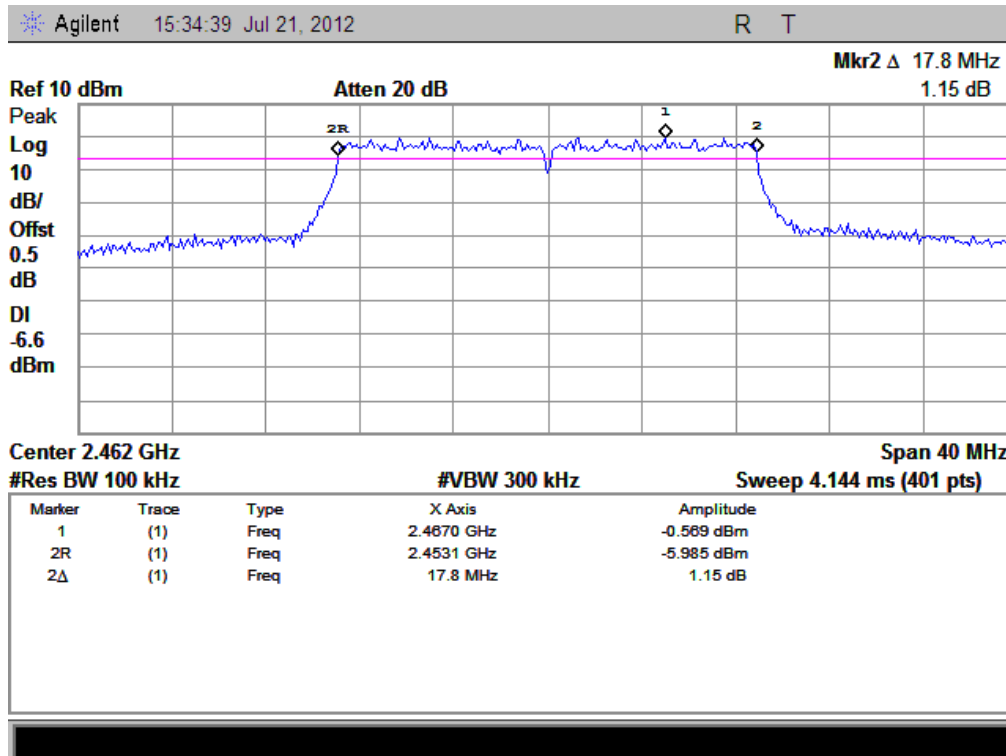

(CH High)

802.11n-40MHz Test Mode

| Channel | Frequency (MHz) | 6 dB Bandwidth (MHz) | Limits (kHz) | Result |
|---------|-----------------|----------------------|--------------|--------|
| 3 | 2422 | 35.85 | ≥500 | PASS |
| 6 | 2437 | 36.45 | ≥500 | PASS |
| 9 | 2452 | 36.00 | ≥500 | PASS |

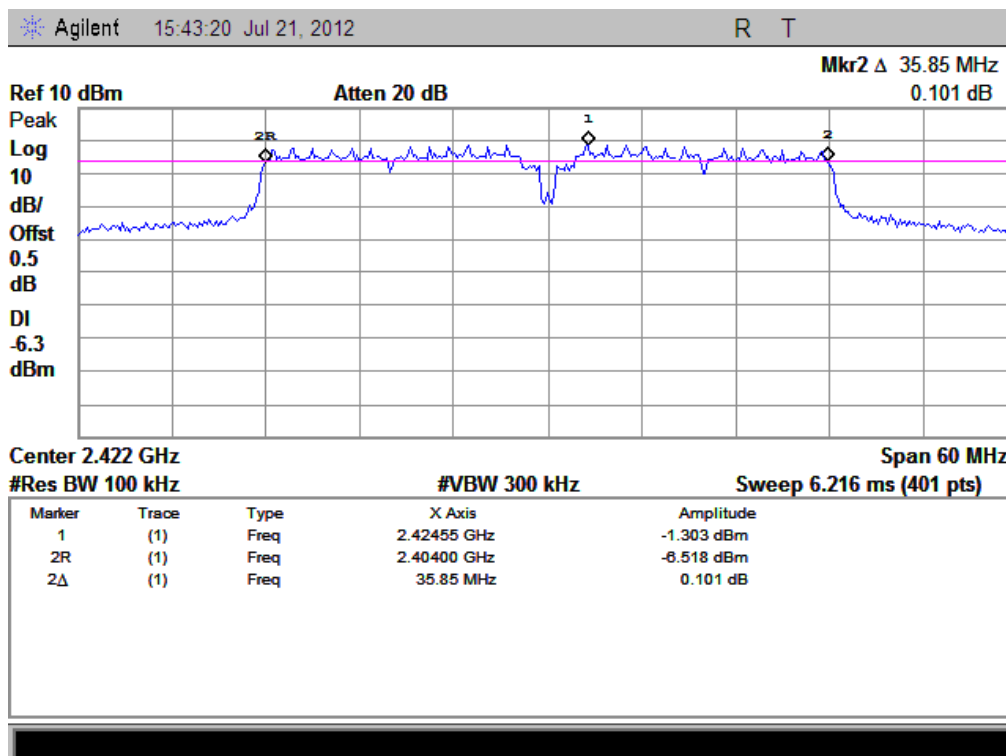

(CH Low)

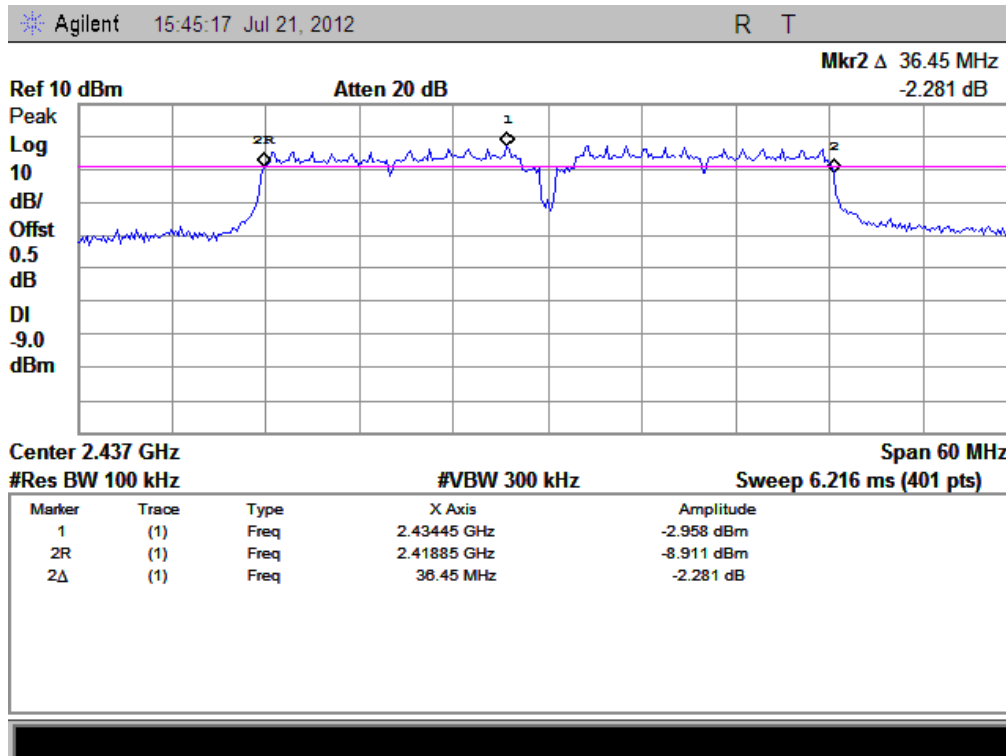

(CH Mid)

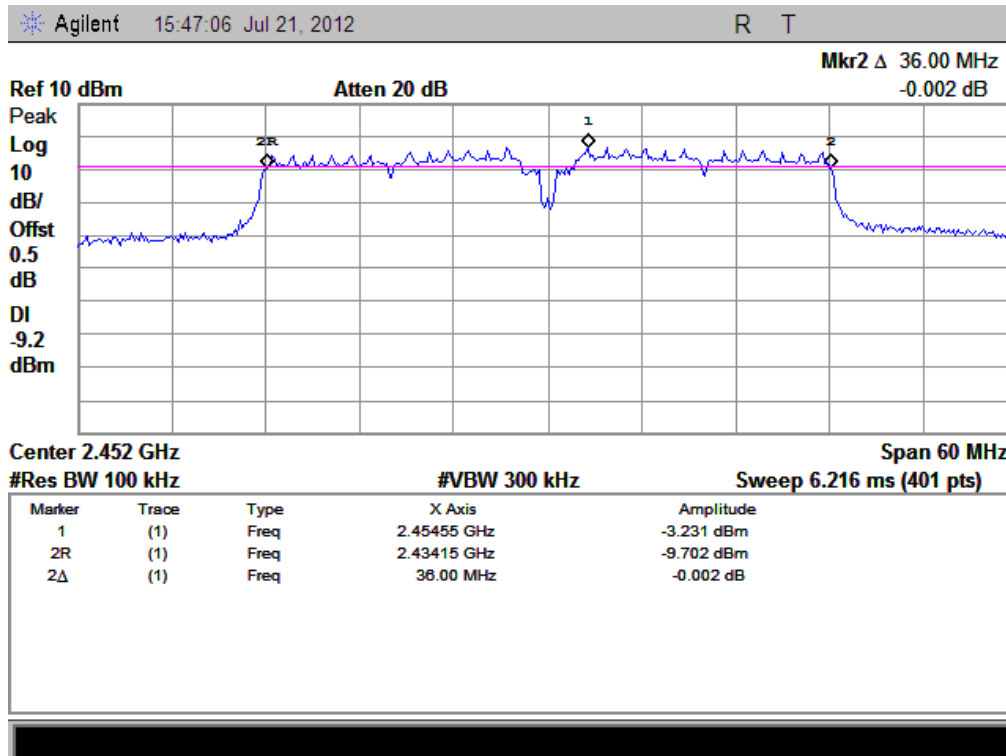

(CH High)

5.2 Peak Output Power

5.2.1 Definition

For systems using digital modulation in the 902–928 MHz, 2400–2483.5 MHz, and 5725–5850 MHz bands: 1 Watt. As an alternative to a peak power measurement, compliance with the one Watt limit can be based on a measurement of the maximum conducted output power.

5.2.2 Test Description



The EUT which is powered by Battery, is coupled to the Power Meter; the RF load attached to the EUT antenna terminal is 50Ohm; the path loss as the factor is calibrated to correct the reading.

5.2.3 Test Result

The lowest, middle and highest channels are selected to perform testing to verify the conducted RF output peak power of the Module.

802.11b Test Mode

| Channel | Frequency (MHz) | Rate (Mbps) | Measured Output Peak Power | | Limit | | Verdict |
|---------|-----------------|-------------|----------------------------|-------|-------|---|---------|
| | | | dBm | W | dBm | W | |
| 1 | 2412 | 1Mbps | 16.31 | 0.043 | 30 | 1 | PASS |
| | | 11Mbps | 14.37 | 0.027 | | | PASS |
| 6 | 2437 | 1Mbps | 16.22 | 0.042 | | | PASS |
| | | 11Mbps | 13.98 | 0.025 | | | PASS |
| 11 | 2462 | 1Mbps | 16.49 | 0.045 | | | PASS |
| | | 11Mbps | 14.72 | 0.030 | | | PASS |

802.11g Test Mode

| Channel | Frequency (MHz) | Rate (Mbps) | Measured Output Peak Power | | Limit | | Verdict |
|---------|-----------------|-------------|----------------------------|-------|-------|---|---------|
| | | | dBm | W | dBm | W | |
| 1 | 2412 | 6Mbps | 14.11 | 0.026 | 30 | 1 | PASS |
| | | 54Mbps | 13.46 | 0.022 | | | PASS |
| 6 | 2437 | 6Mbps | 14.39 | 0.027 | | | PASS |
| | | 54Mbps | 12.91 | 0.020 | | | PASS |
| 11 | 2462 | 6Mbps | 14.55 | 0.029 | | | PASS |
| | | 54Mbps | 12.65 | 0.018 | | | PASS |

802.11n Test Mode (Standard-20 MHz Channel mode)

| Channel | Frequency (MHz) | Rate (Mbps) | Measured Output Peak Power | | Limit | | Verdict |
|---------|-----------------|-------------|----------------------------|-------|-------|---|---------|
| | | | dBm | W | dBm | W | |
| 1 | 2412 | 6.5Mbps | 13.78 | 0.024 | 30 | 1 | PASS |
| | | 65Mbps | 12.14 | 0.016 | | | PASS |
| 6 | 2437 | 6.5Mbps | 14.03 | 0.025 | | | PASS |
| | | 65Mbps | 12.57 | 0.018 | | | PASS |
| 11 | 2462 | 6.5Mbps | 13.65 | 0.023 | | | PASS |
| | | 65Mbps | 11.99 | 0.016 | | | PASS |

802.11n Test Mode (Standard-40 MHz Channel mode)

| Channel | Frequency (MHz) | Rate (Mbps) | Measured Output Peak Power | | Limit | | Verdict |
|---------|-----------------|-------------|----------------------------|-------|-------|---|---------|
| | | | dBm | W | dBm | W | |
| 3 | 2422 | 13.5Mbps | 13.15 | 0.021 | 30 | 1 | PASS |
| | | 135Mbps | 11.63 | 0.015 | | | PASS |
| 6 | 2437 | 13.5Mbps | 12.88 | 0.019 | | | PASS |
| | | 135Mbps | 11.85 | 0.015 | | | PASS |
| 9 | 2452 | 13.5Mbps | 12.72 | 0.019 | | | PASS |
| | | 135Mbps | 11.57 | 0.014 | | | PASS |

5.3 Conducted Spurious Emission

5.3.1 Definition

In any 100 kHz bandwidth outside the frequency band in which the spread spectrum or digitally modulated intentional radiator is operating, the radio frequency power that is produced by the intentional radiator shall be at least 20 dB below that in the 100 kHz bandwidth within the band that contains the highest level of the desired power, based on either an RF conducted or a radiated measurement, provided the transmitter demonstrates compliance with the peak conducted power limits.

5.3.2 Test Description

See section 5.1.2 of this report.

5.3.3 Test Result

The measurement frequency range is from 30MHz to the 10th harmonic of the fundamental frequency. The lowest, middle and highest channels are tested to verify the spurious emissions.

802.11b Test Mode

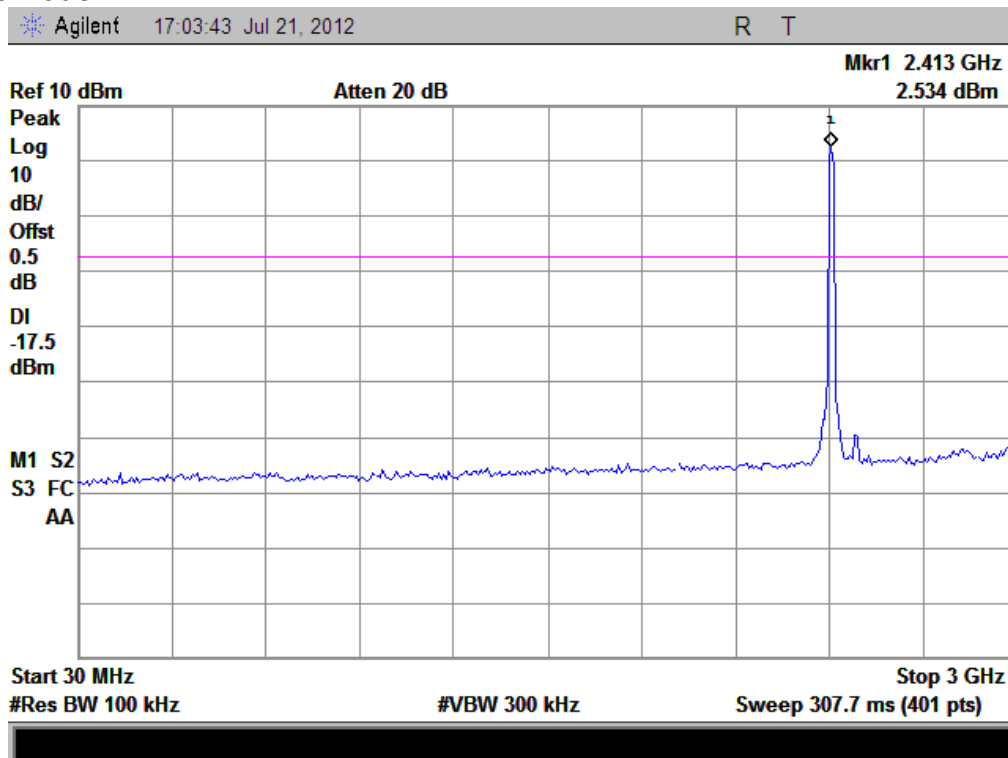

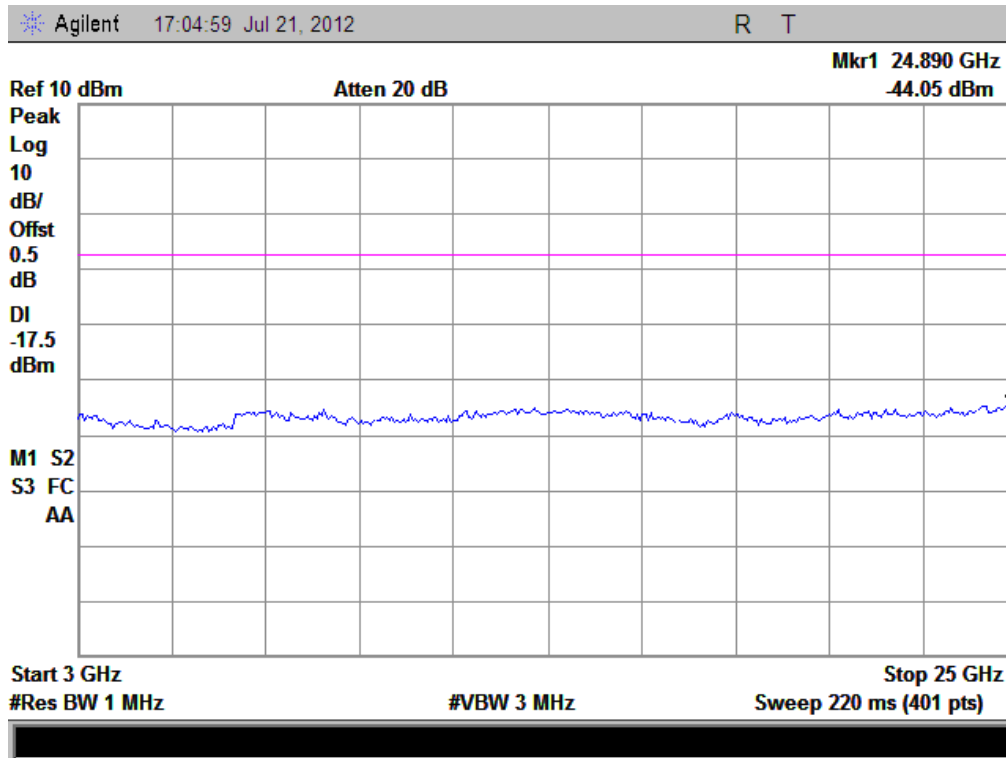

(CH Low, 30MHz to 25GHz)

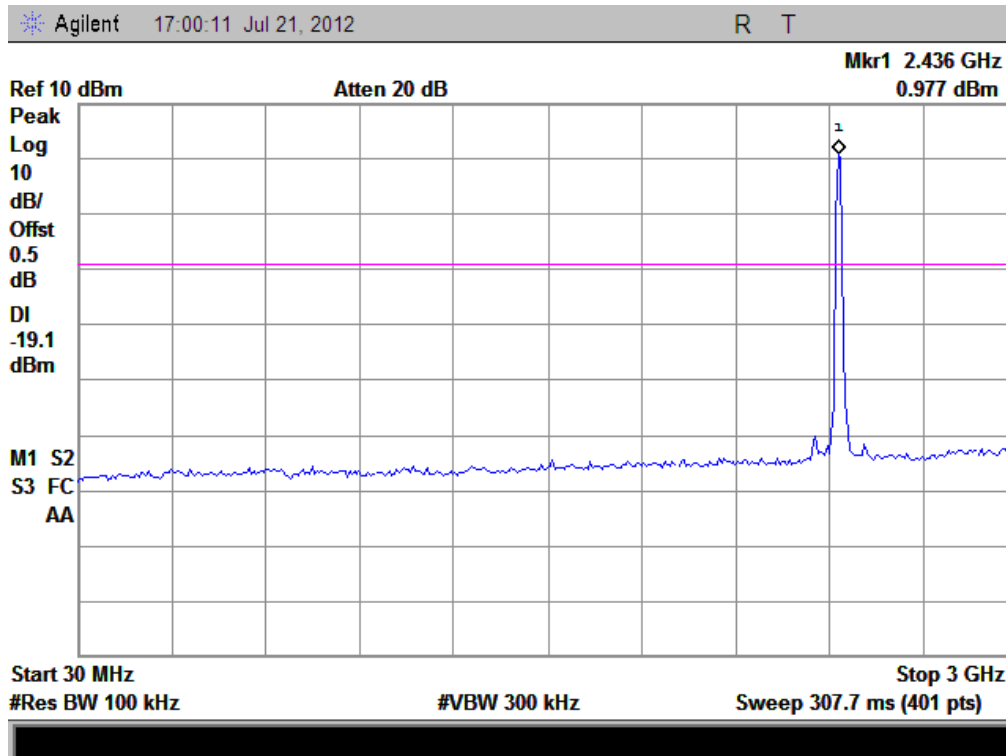

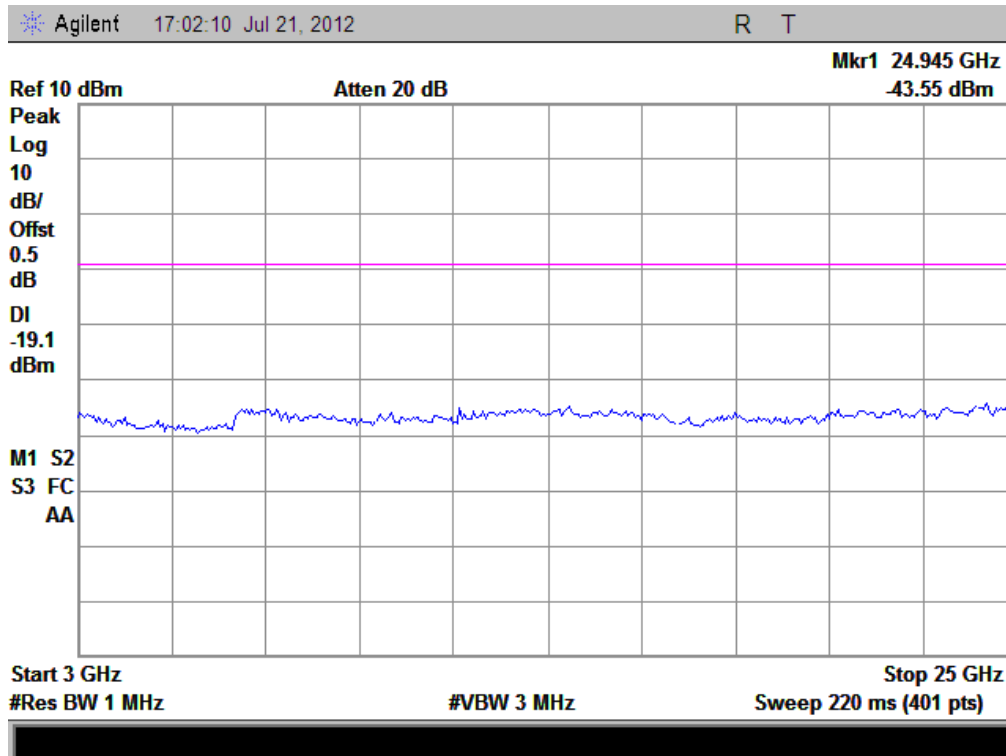

(CH Mid, 30MHz to 25GHz)

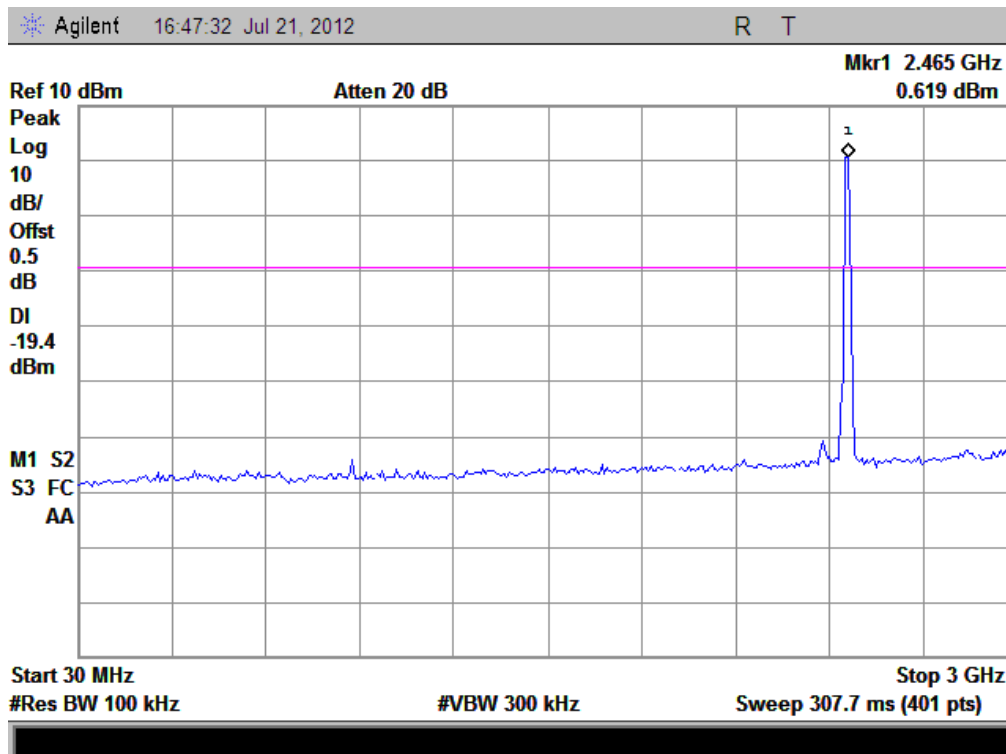

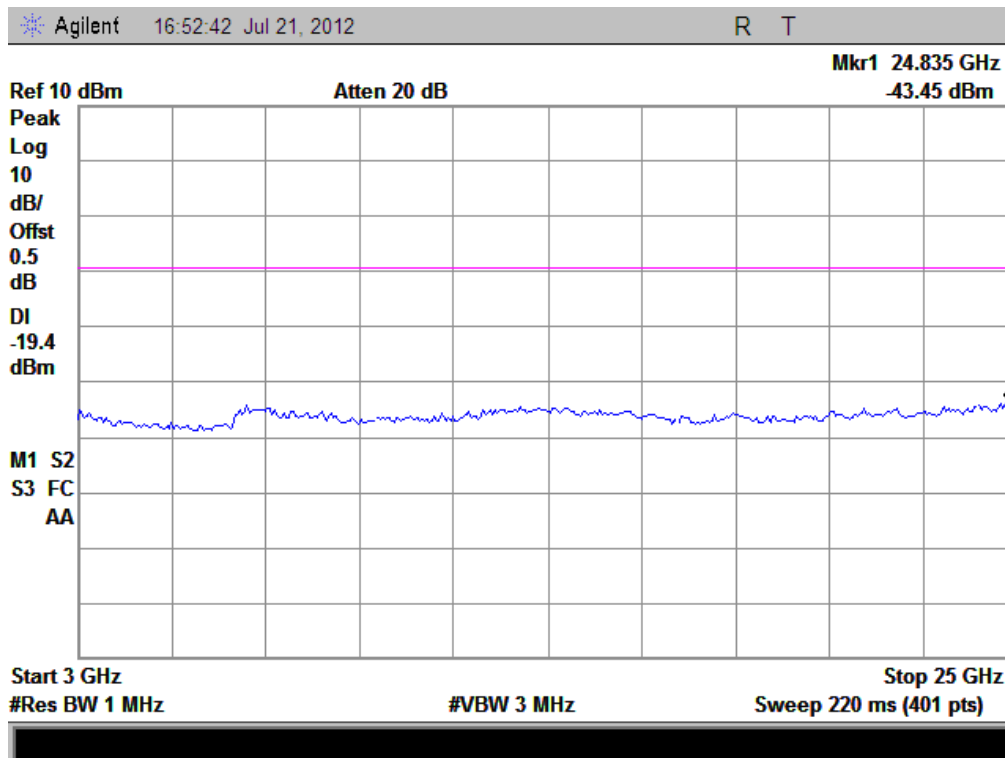

(CH High, 30MHz to 25GHz)

Note: The power of the Module transmitting frequency should be ignored.

802.11g Test Mode

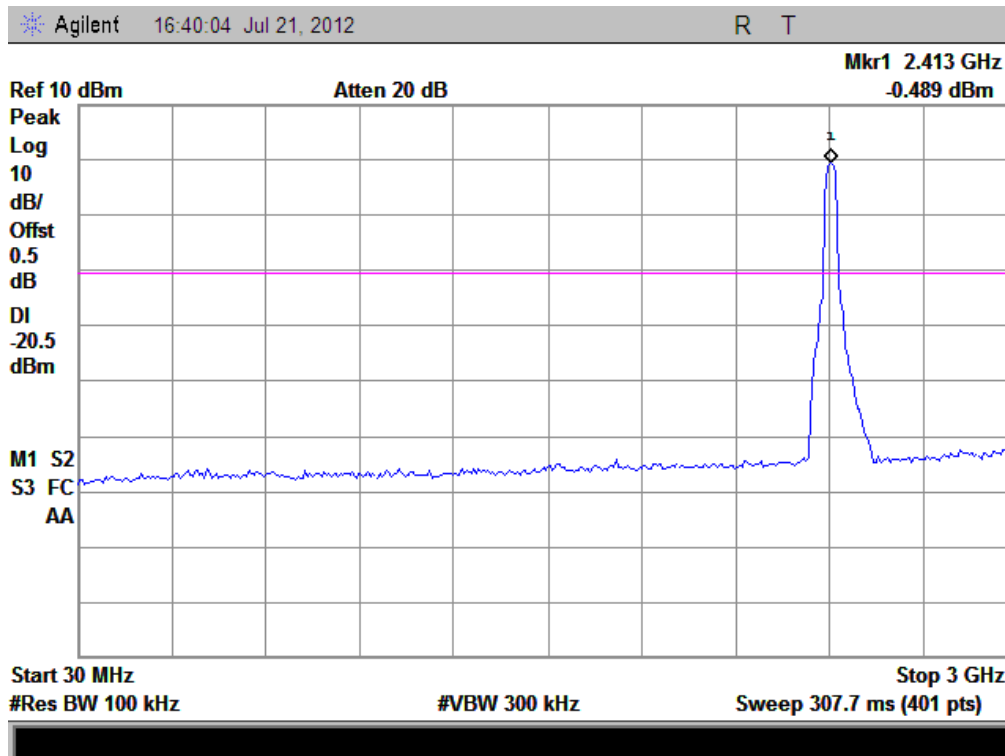

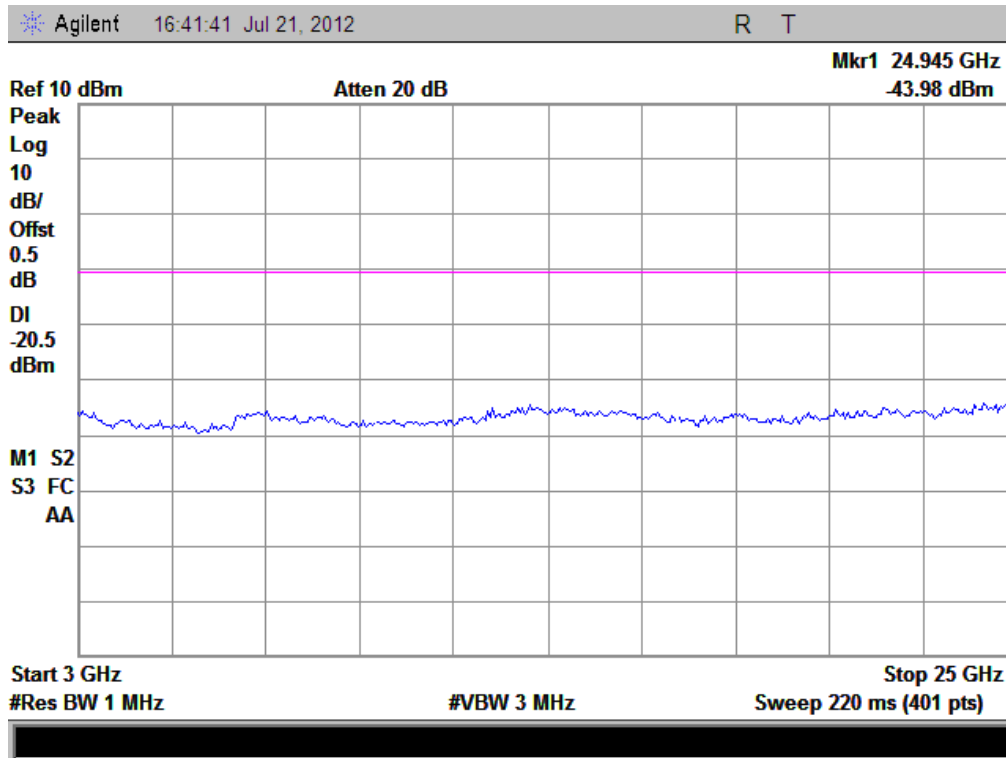

(CH Low, 30MHz to 25GHz)

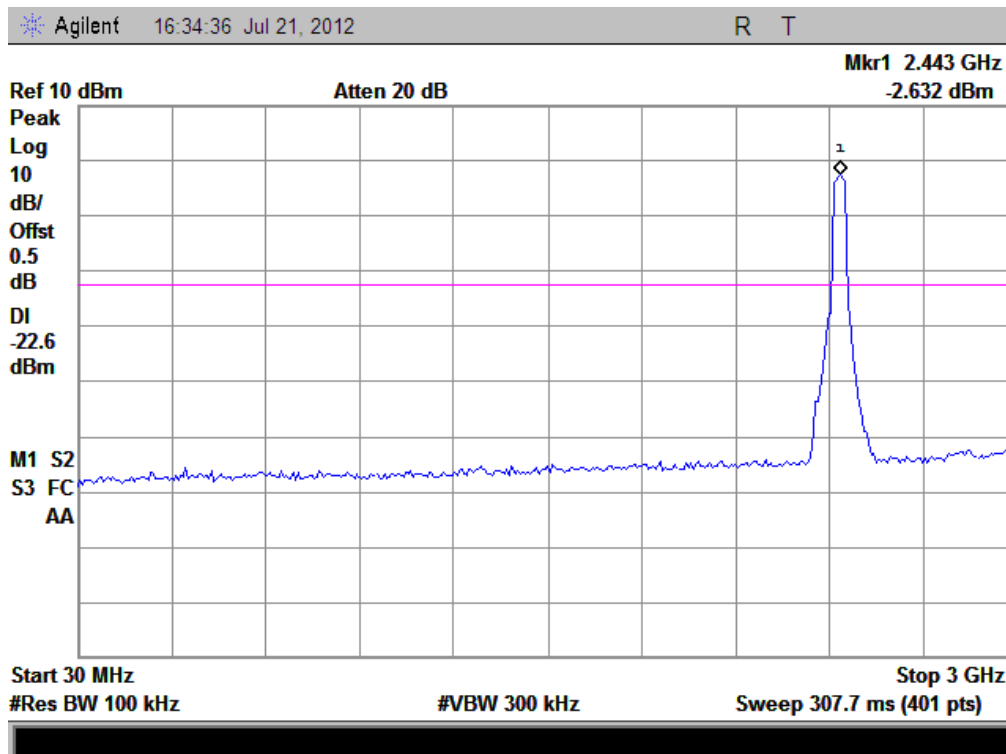

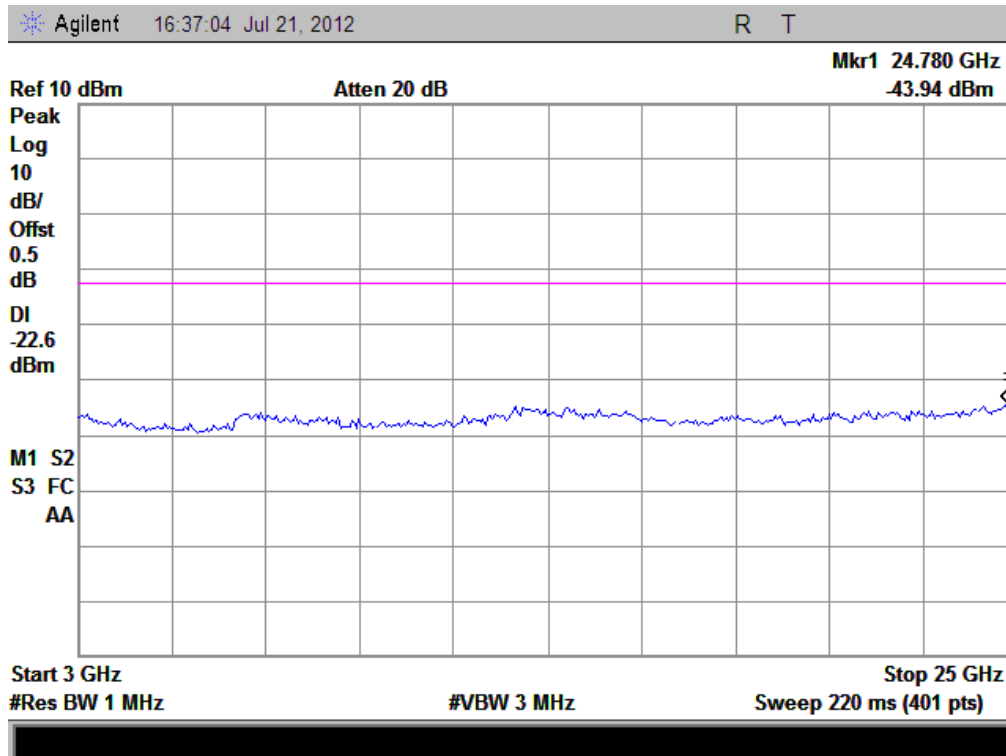

(CH Mid, 30MHz to 25GHz)

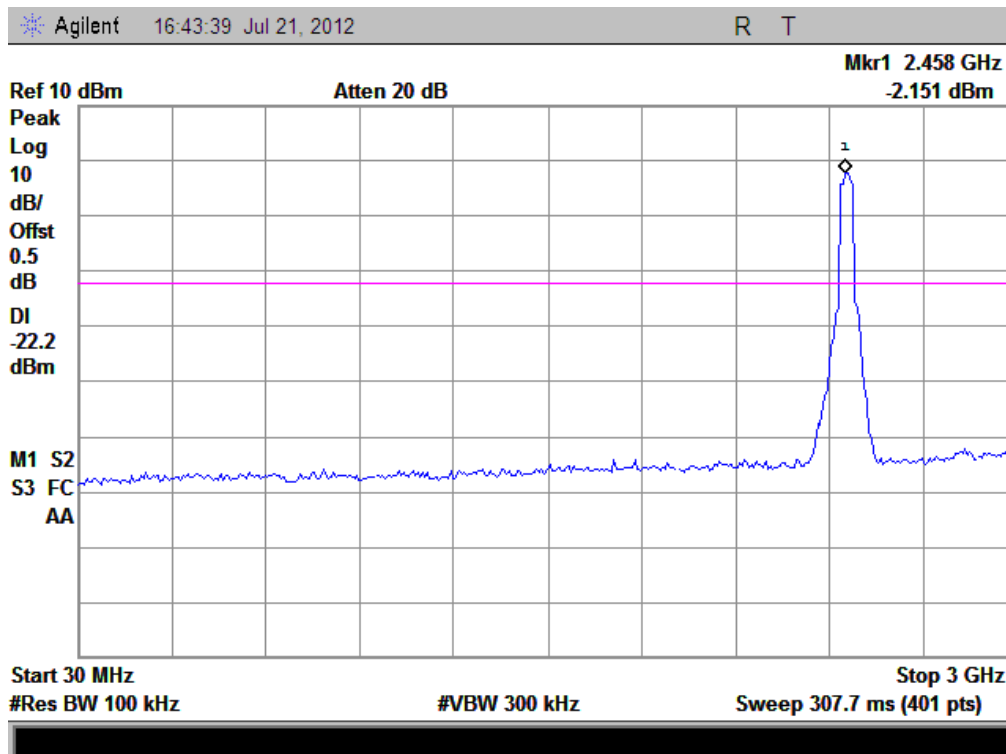

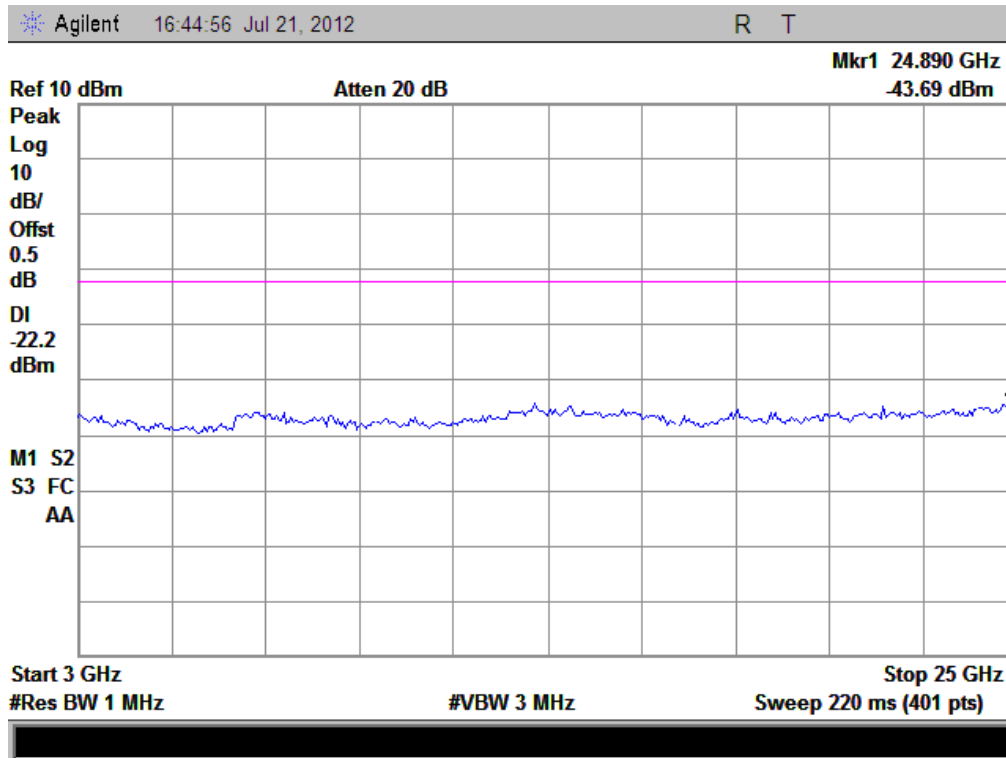

(CH High, 30MHz to 25GHz)

Note: The power of the Module transmitting frequency should be ignored.

802.11n-20MHz Test Mode

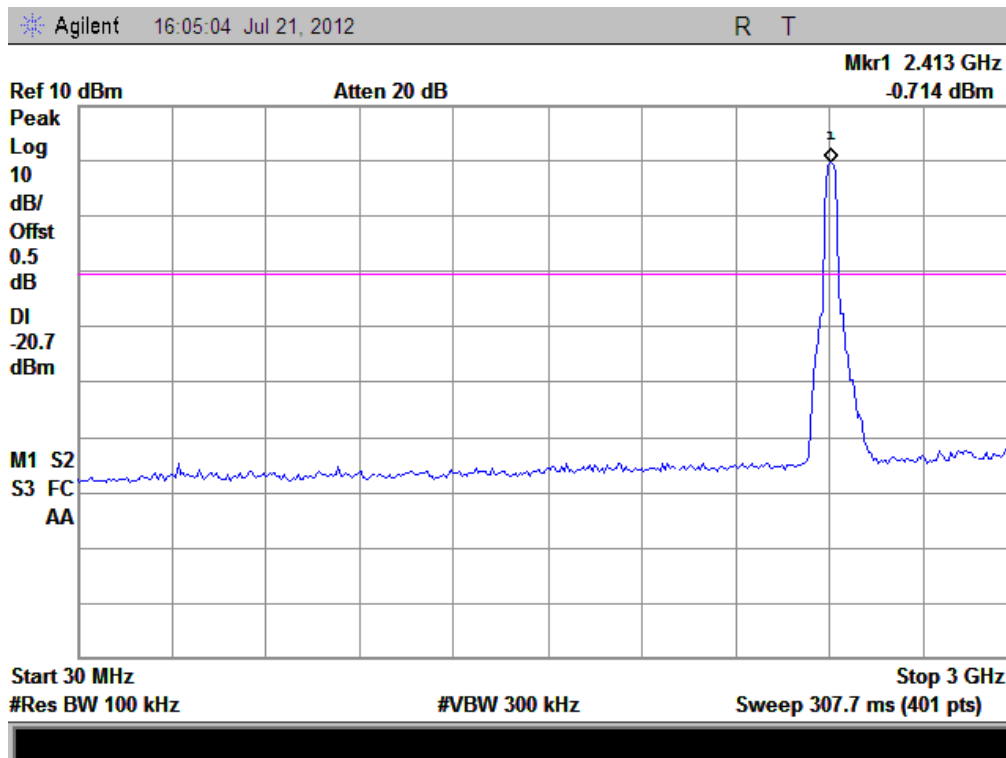

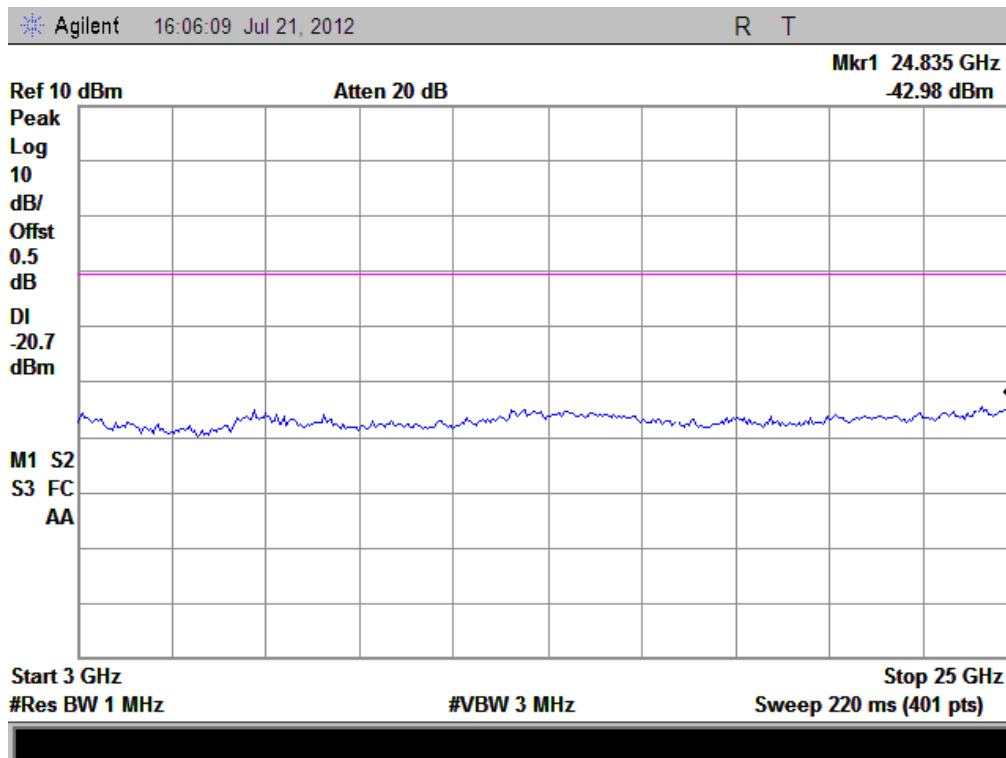

(CH Low, 30MHz to 25GHz)

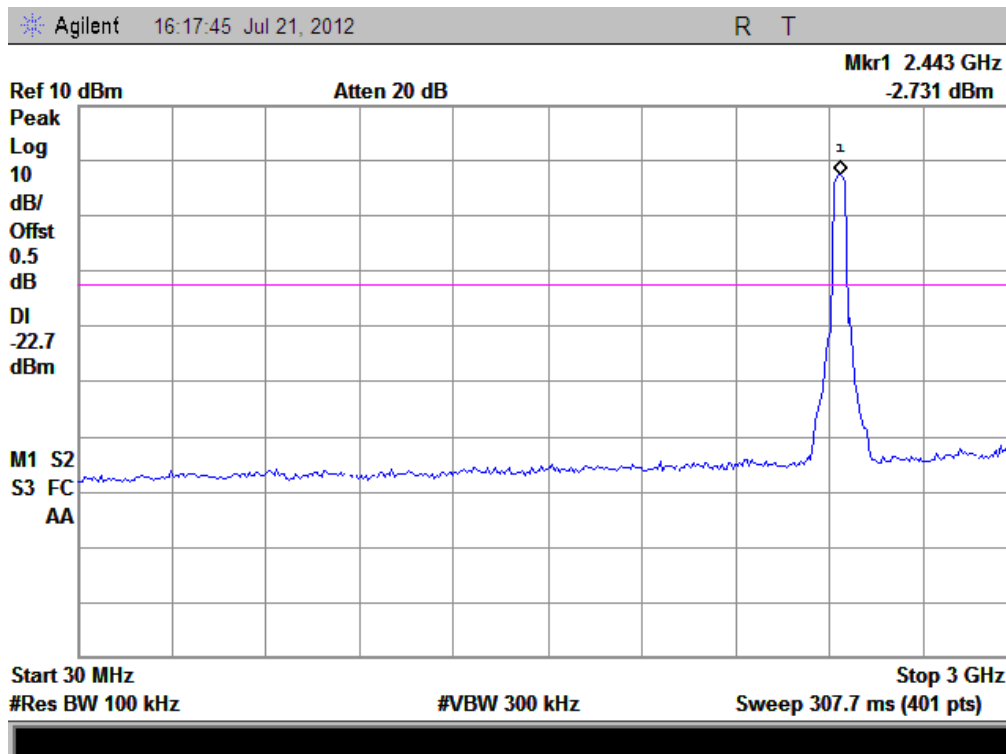

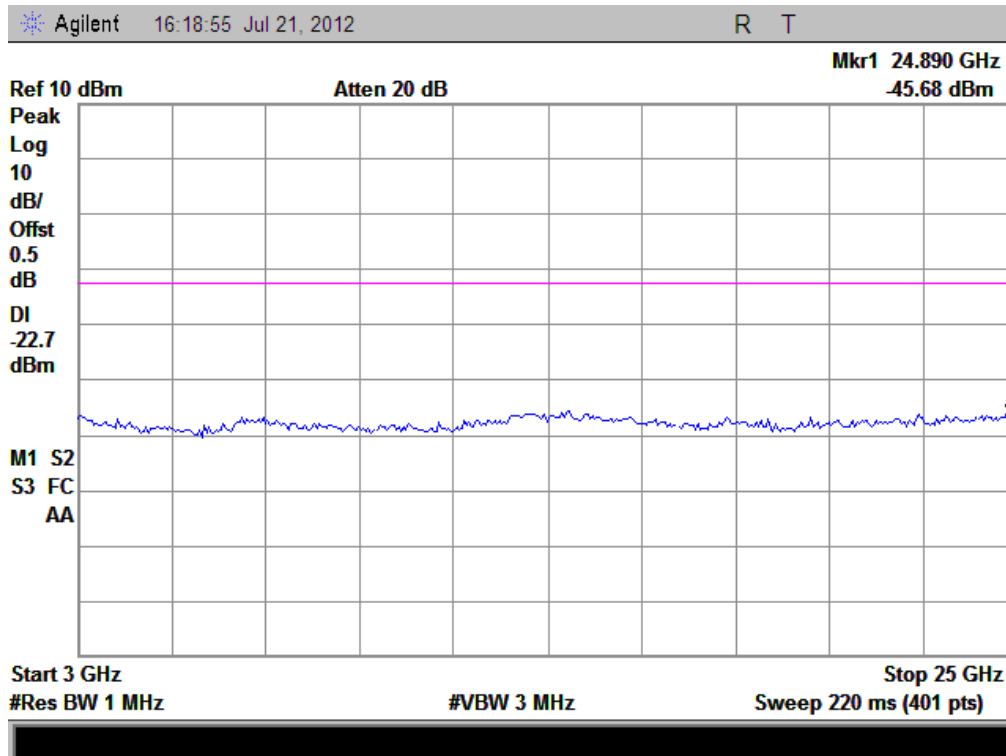

(CH Mid, 30MHz to 25GHz)

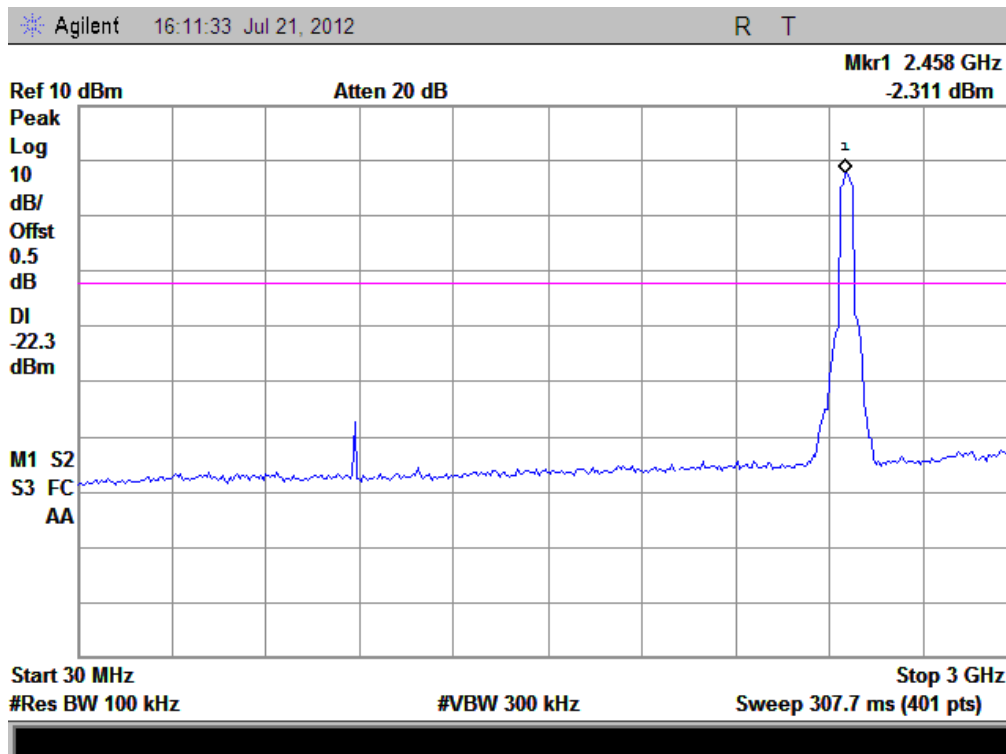

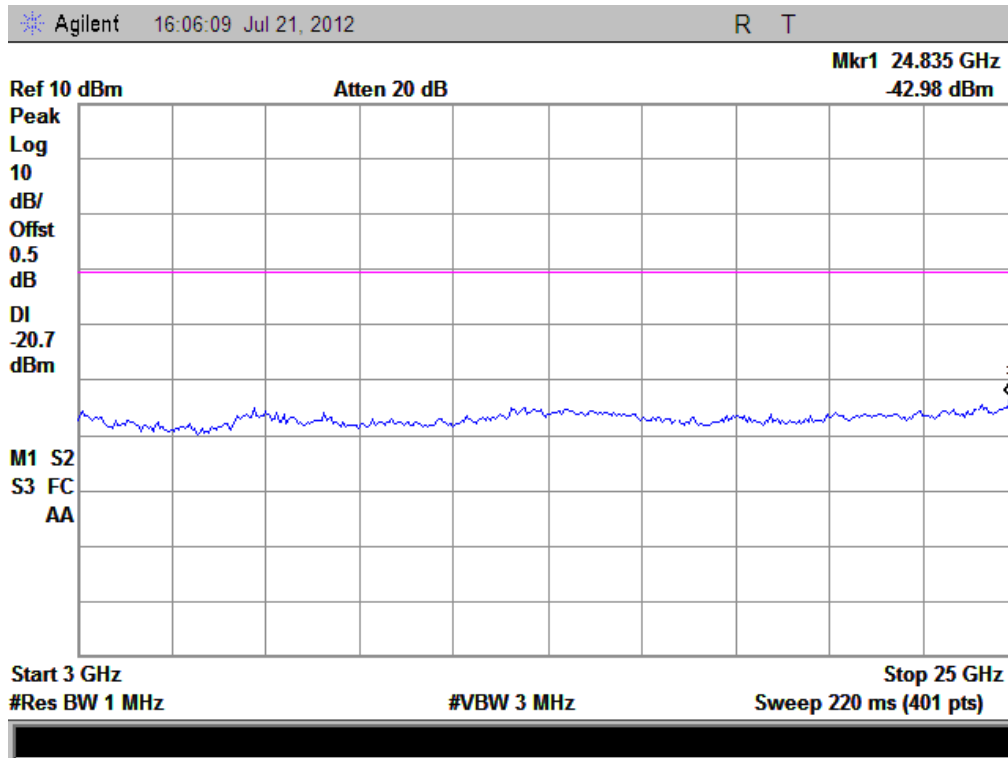

(CH High, 30MHz to 25GHz)

Note: The power of the Module transmitting frequency should be ignored.

802.11n-40MHz Test Mode

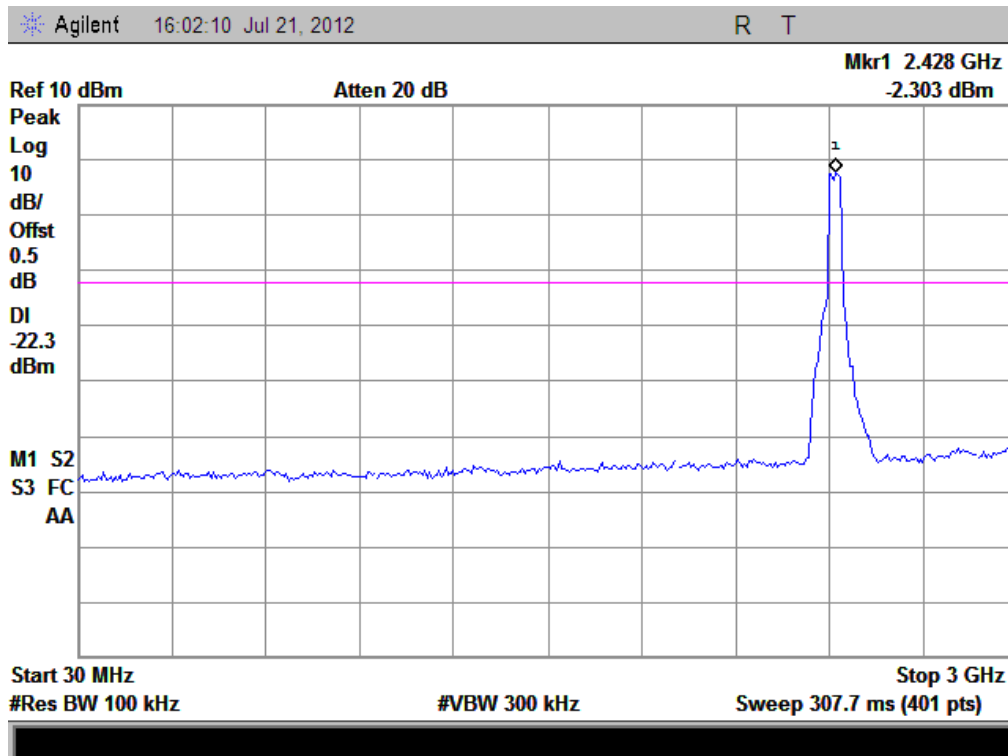

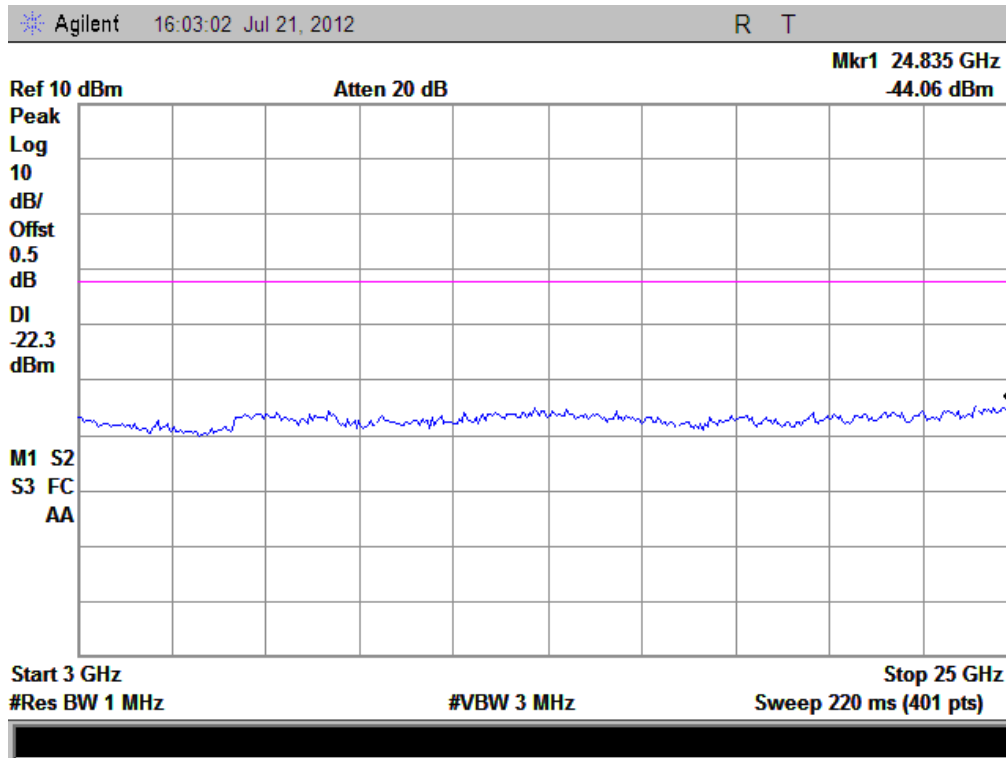

(CH Low, 30MHz to 25GHz)

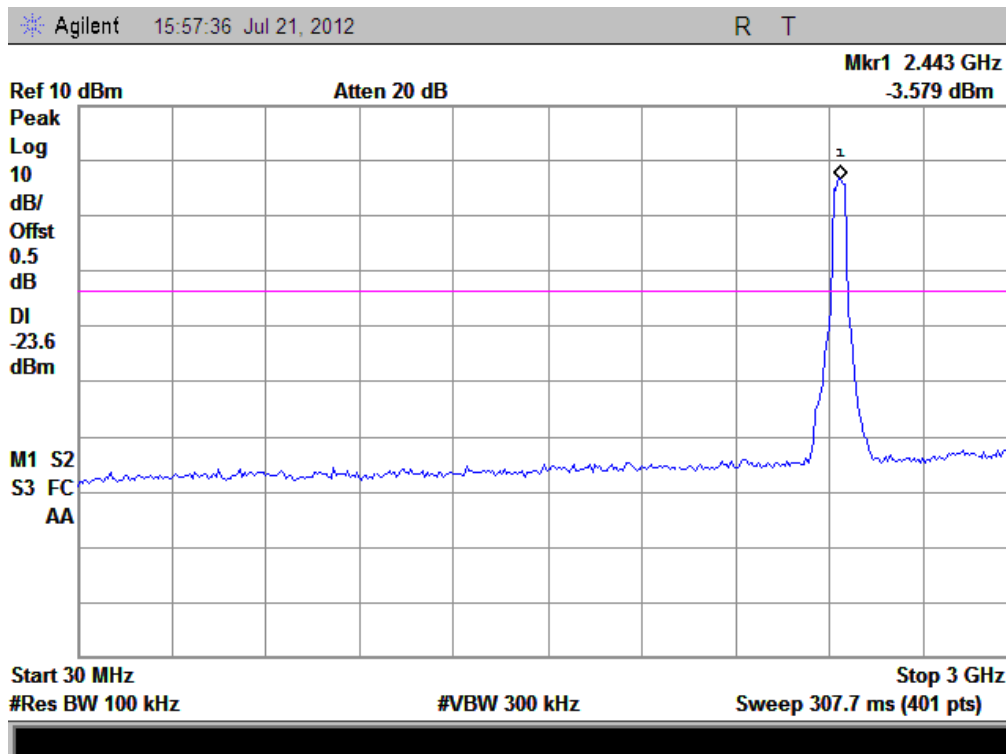

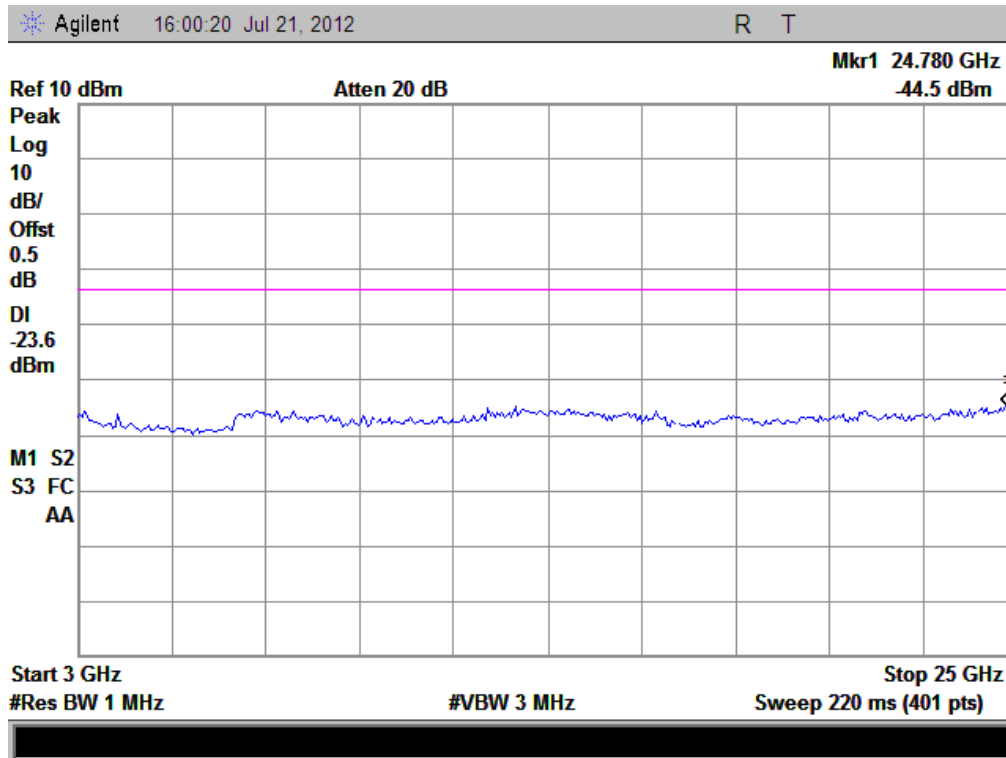

(CH Mid, 30MHz to 25GHz)

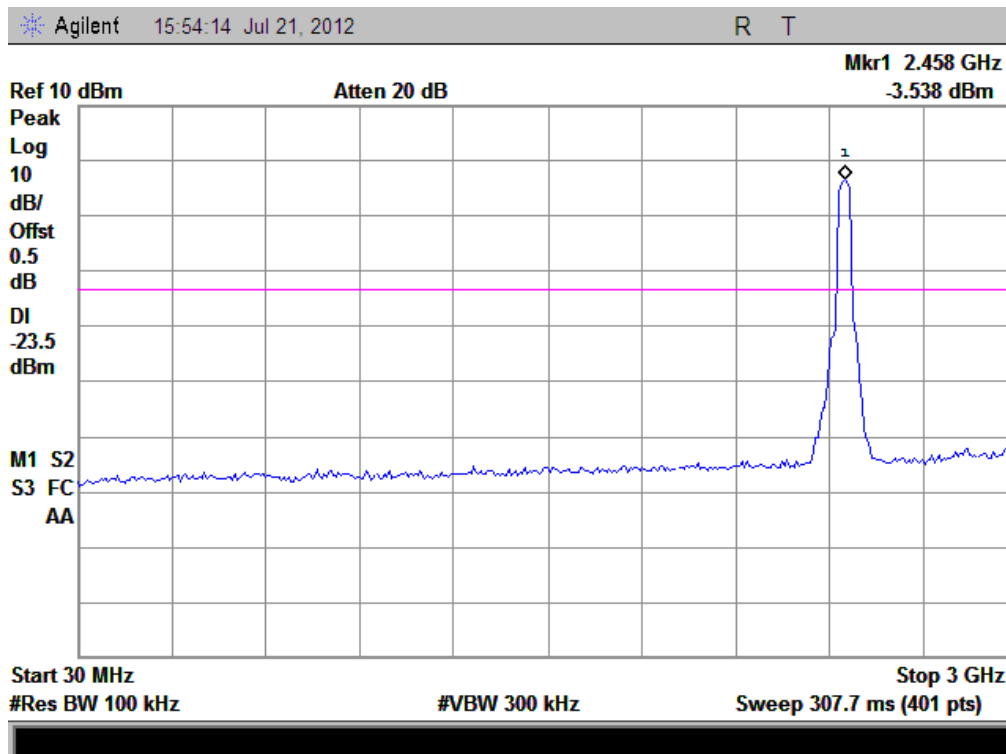

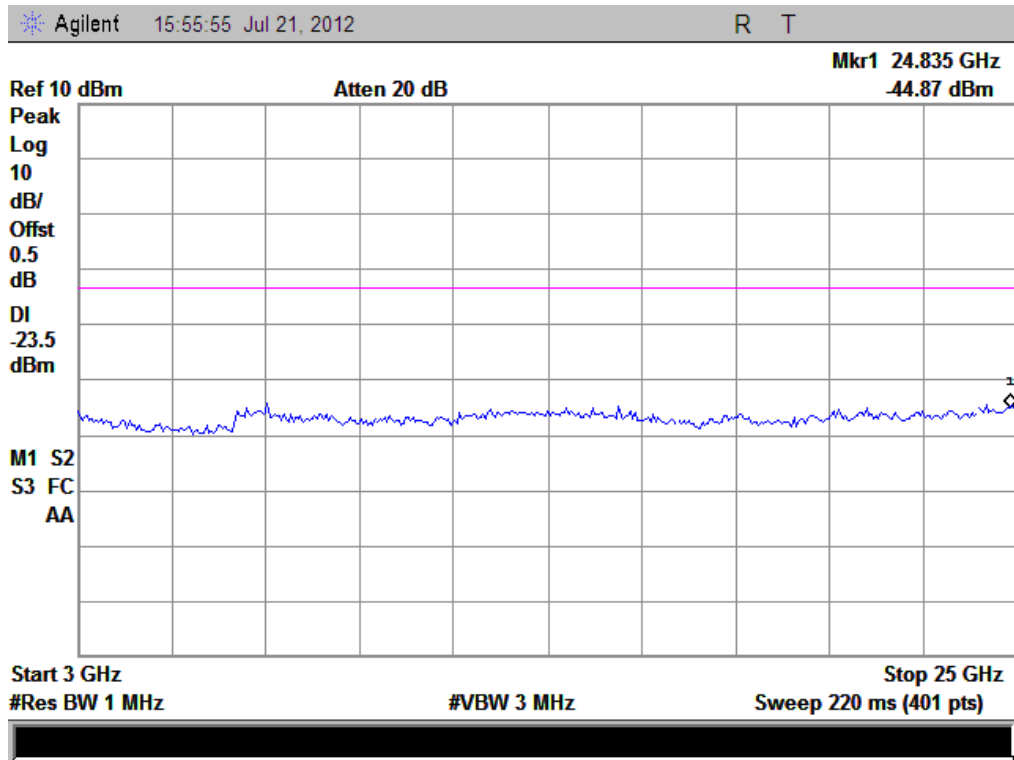

(CH High, 30MHz to 25GHz)

Note: The power of the Module transmitting frequency should be ignored.

5.4 Band Edge

5.4.1 Definition

In any 100 kHz bandwidth outside the frequency band in which the spread spectrum or digitally modulated intentional radiator is operating, the radio frequency power that is produced by the intentional radiator shall be at least 20 dB below that in the 100 kHz bandwidth within the band that contains the highest level of the desired power, based on either an RF conducted or a radiated measurement, provided the transmitter demonstrates compliance with the peak conducted power limits.

5.4.2 Test Description

See section 5.1.2 of this report.

5.4.3 Test Result

The EUT operates at continuous transmit test mode. The test data of the lowest and highest channels are tested to verify the band edge emissions.

802.11b Test Mode

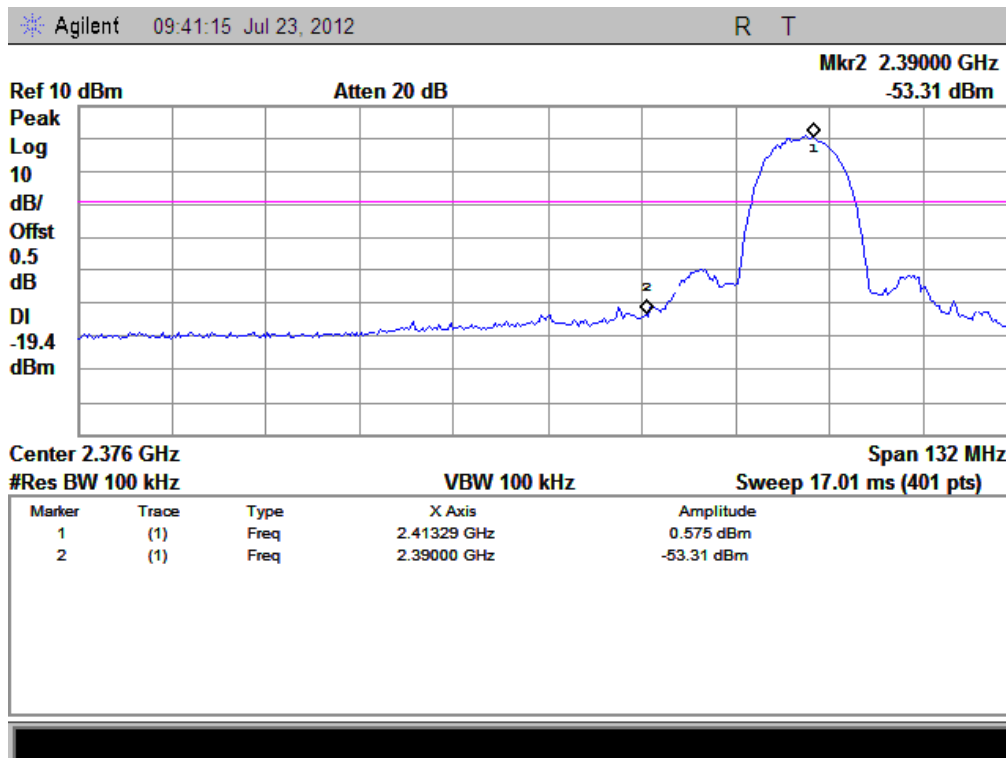

(CH Low)

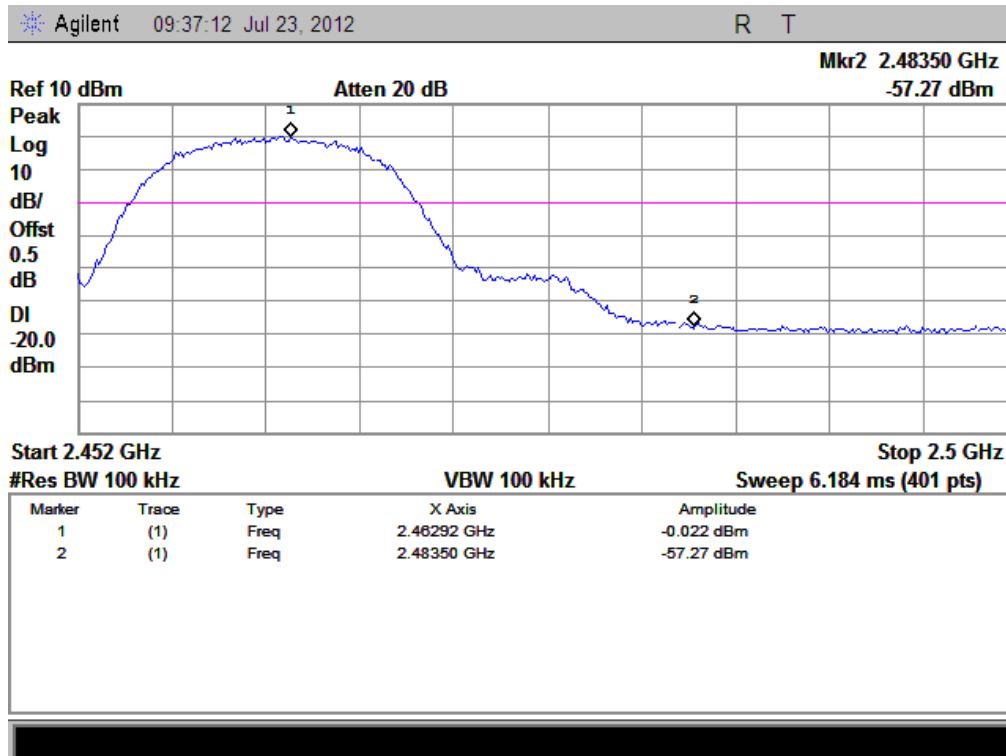

(CH High)

802.11g Test Mode

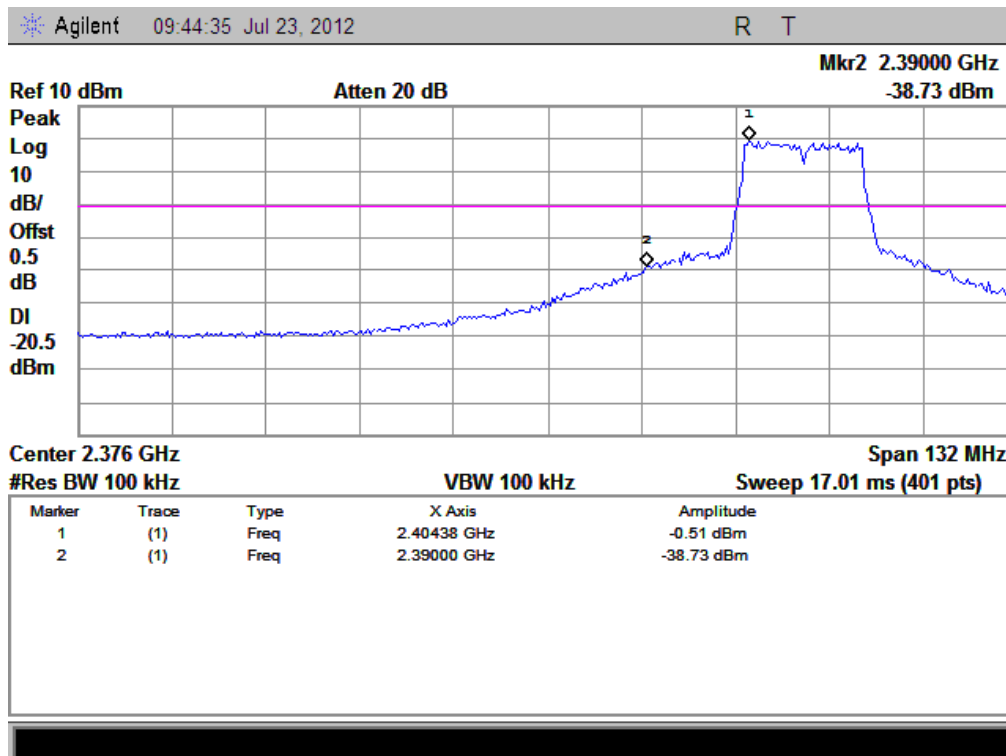

(CH Low)

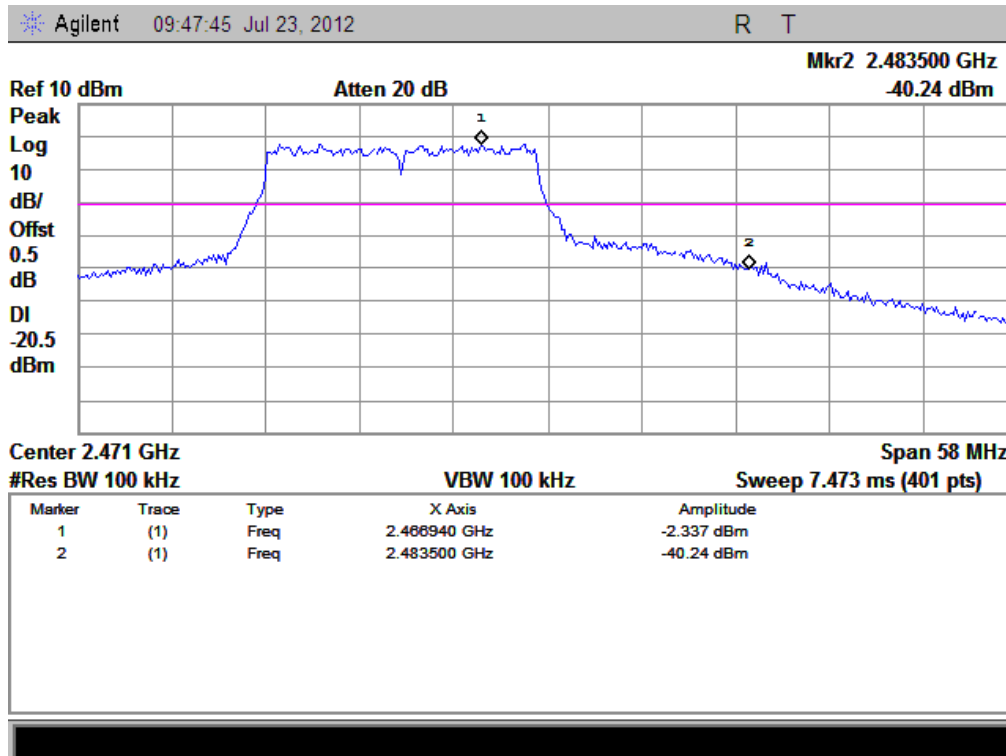

(CH High)

802.11n-20MHz Test Mode

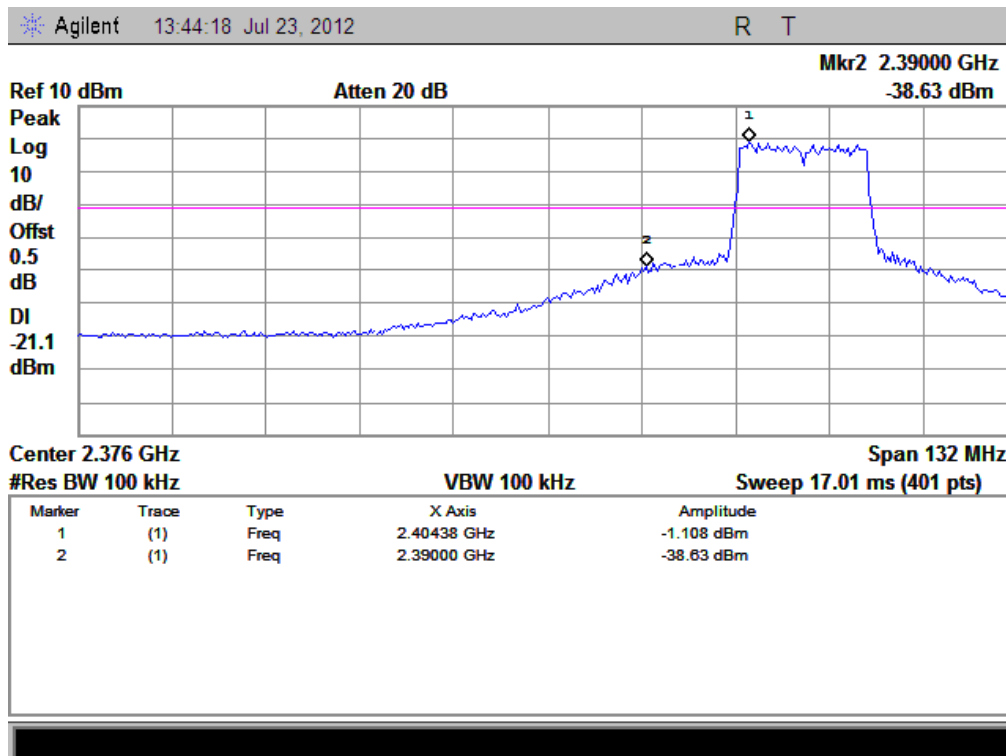

(CH Low)

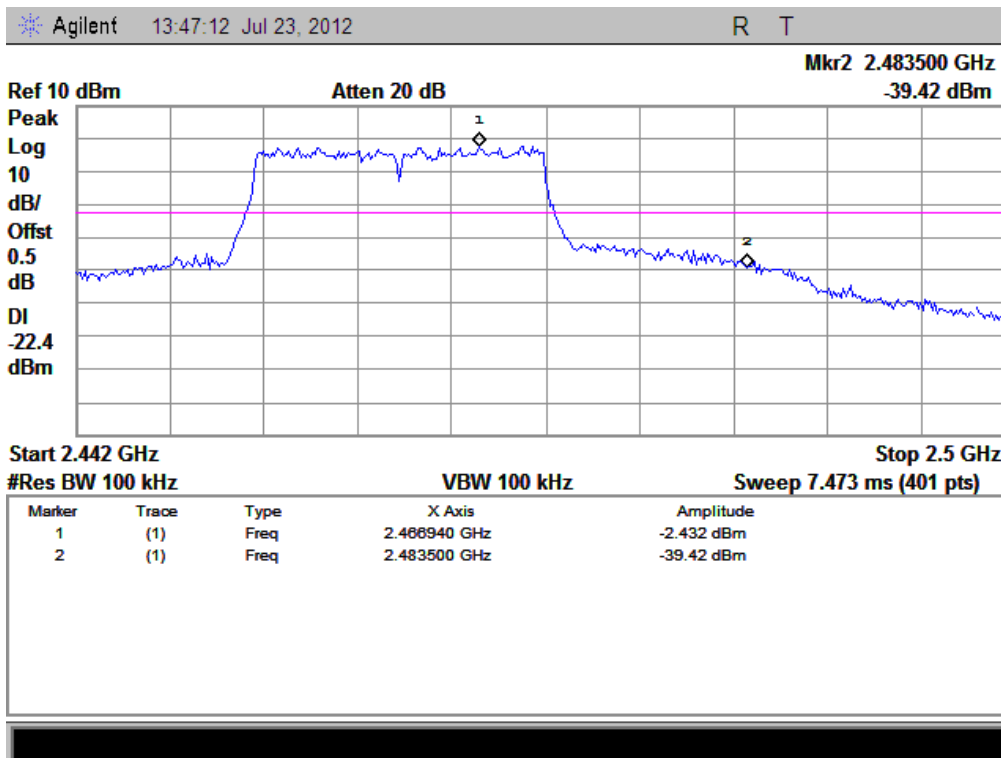

(CH High)

802.11n-40MHz Test Mode

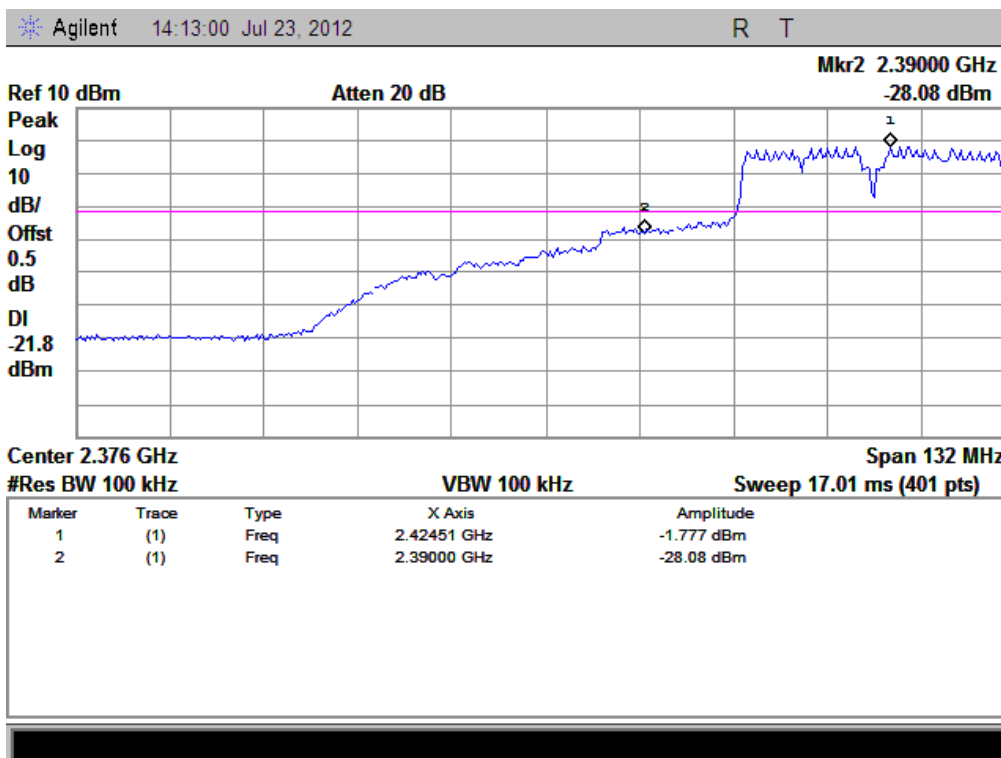

(CH Low)

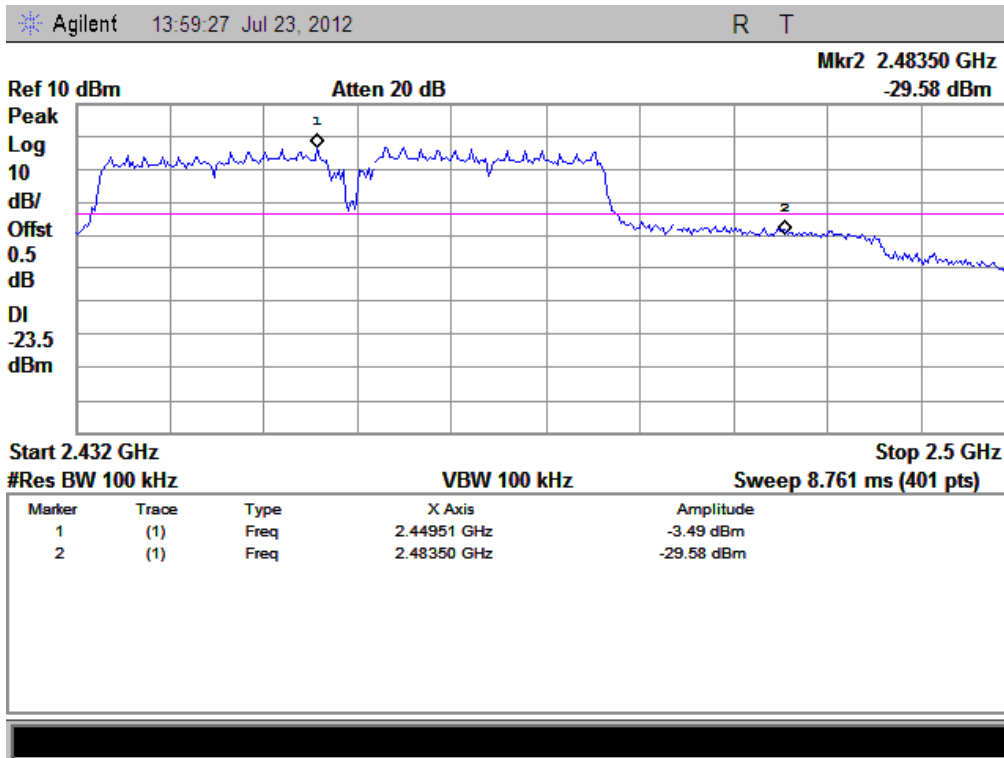

(CH High)

5.5 Power Spectral Density (PSD)

5.5.1 Definition

For digitally modulated systems, the power spectral density conducted from the intentional radiator to the antenna shall not be greater than 8 dBm in any 3 kHz band during any time interval of continuous transmission.

5.5.2 Test Description

See section 5.1.2 of this report.

5.5.3 Test Result

The lowest, middle and highest channels are tested to verify the power spectral density.

802.11b Test Mode

| Channel | Frequency (MHz) | PSD (dBm) | Limits(dBm) | Result |
|---------|-----------------|-----------|-------------|--------|
| 1 | 2412 | -11.66 | ≤8 | PASS |
| 6 | 2437 | -13.77 | ≤8 | PASS |
| 11 | 2462 | -13.49 | ≤8 | PASS |

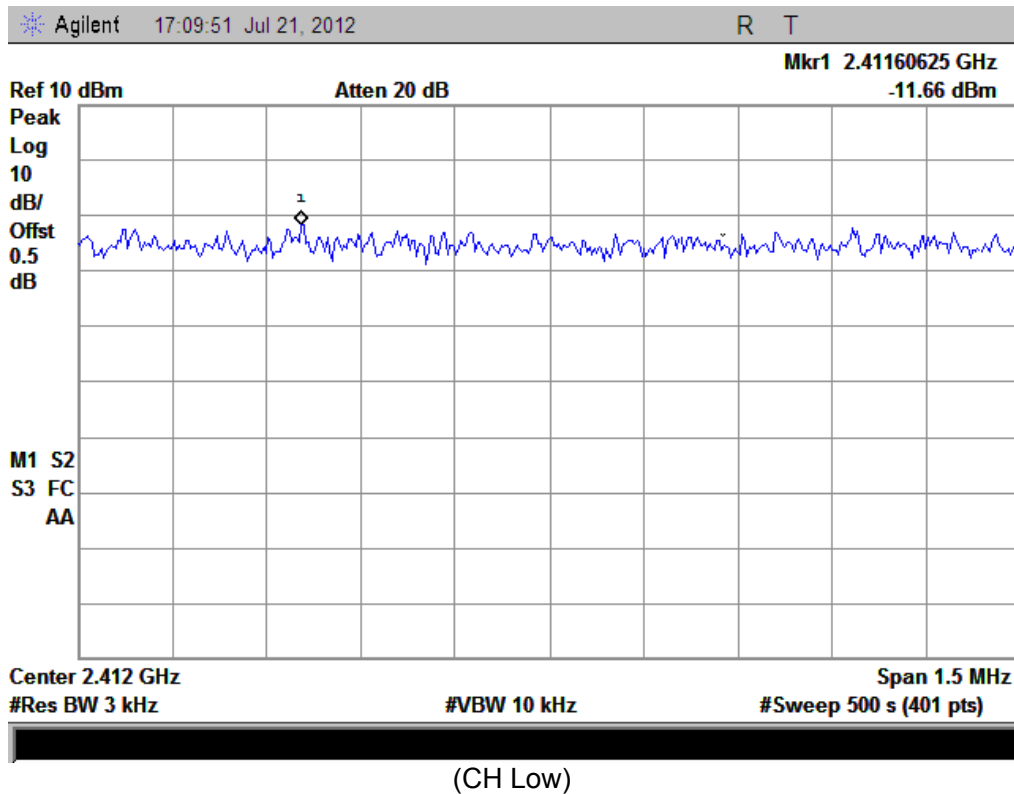

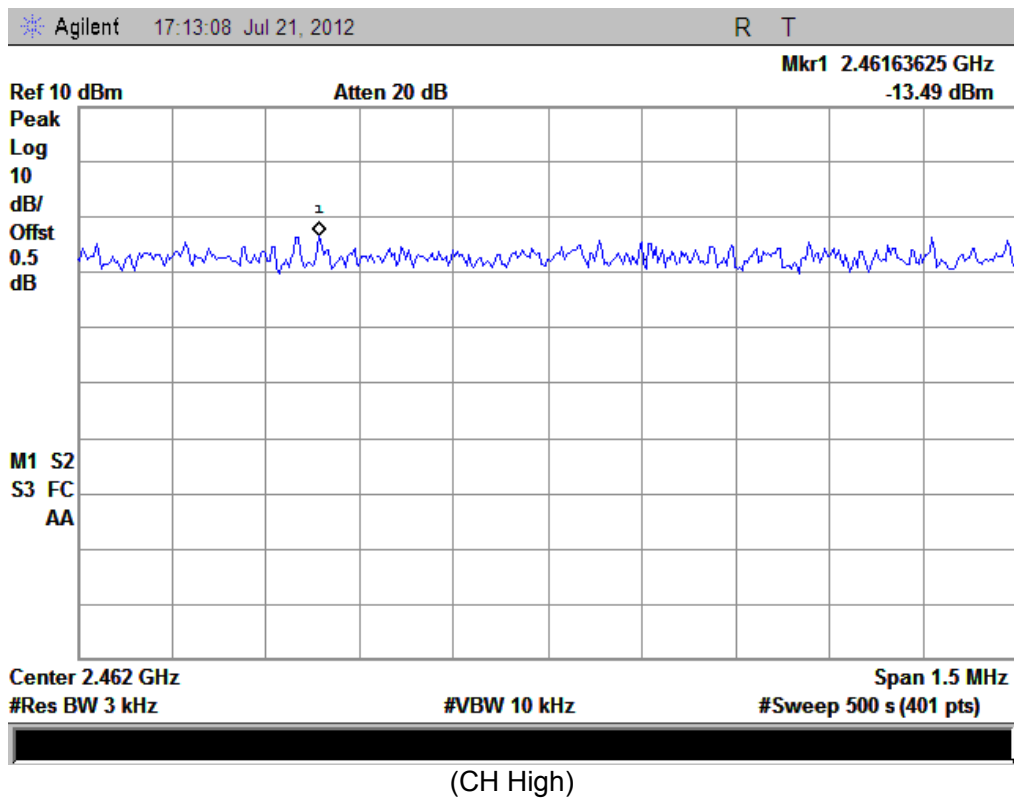
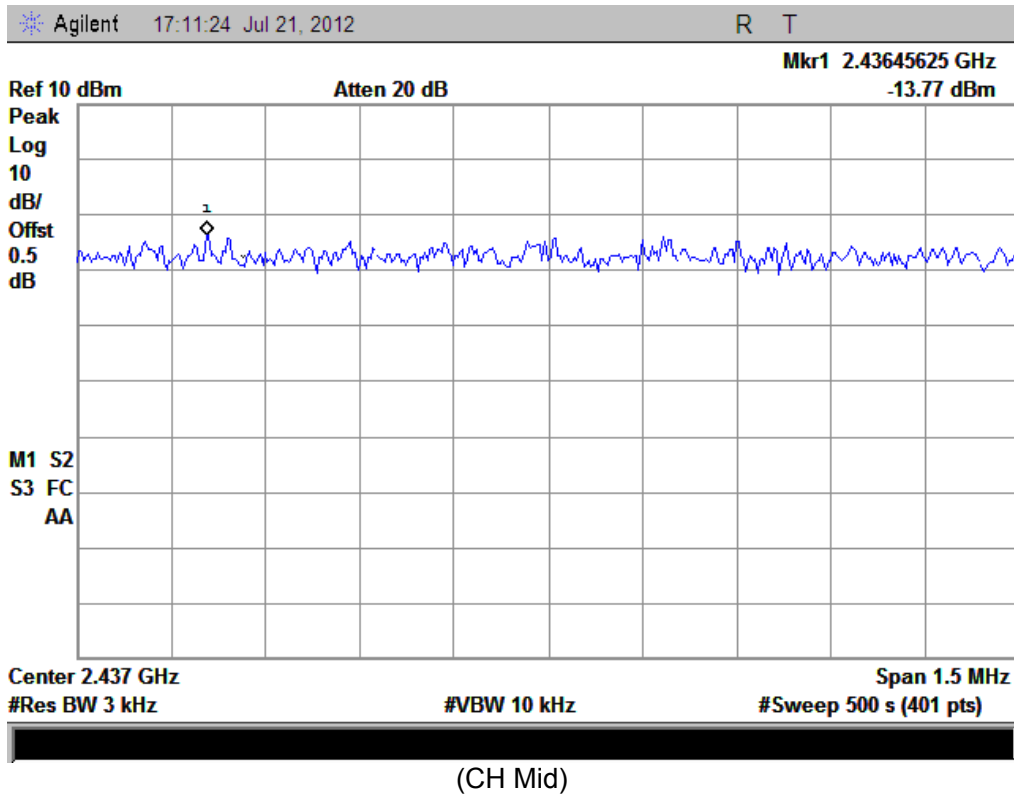

802.11g Test Mode

| Channel | Frequency (MHz) | PSD (dBm) | Limits(dBm) | Result |
|---------|-----------------|-----------|-------------|--------|
| 1 | 2412 | -13.85 | ≤8 | PASS |
| 6 | 2437 | -16.70 | ≤8 | PASS |
| 11 | 2462 | -15.79 | ≤8 | PASS |

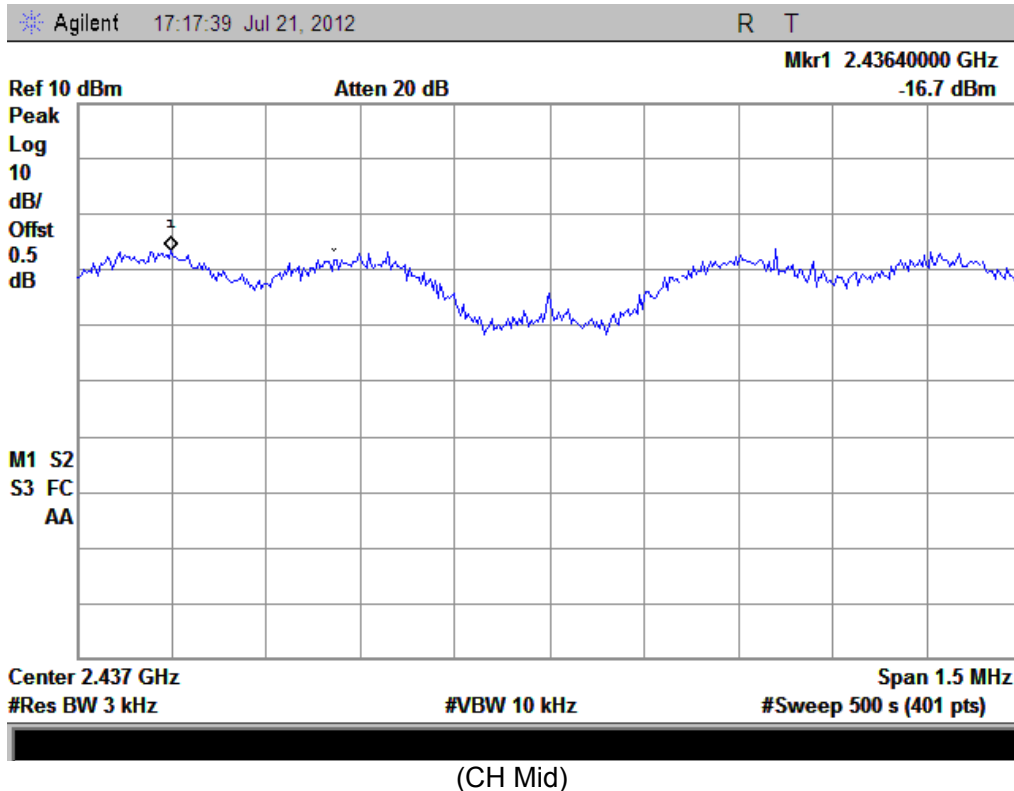
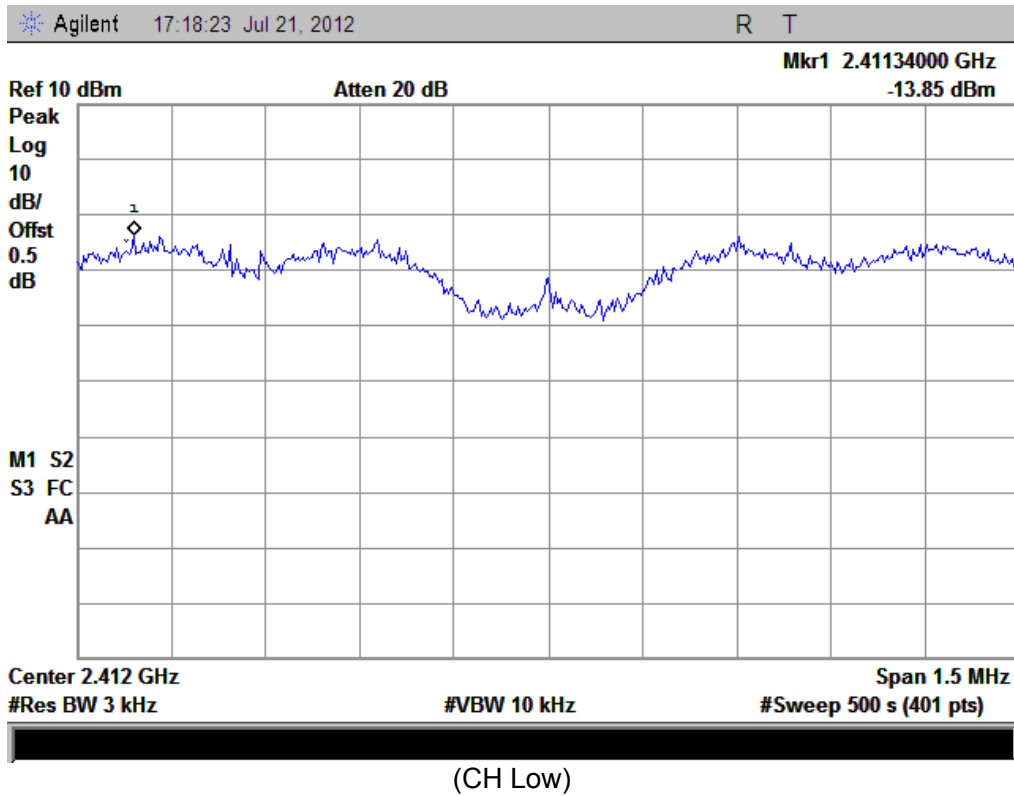

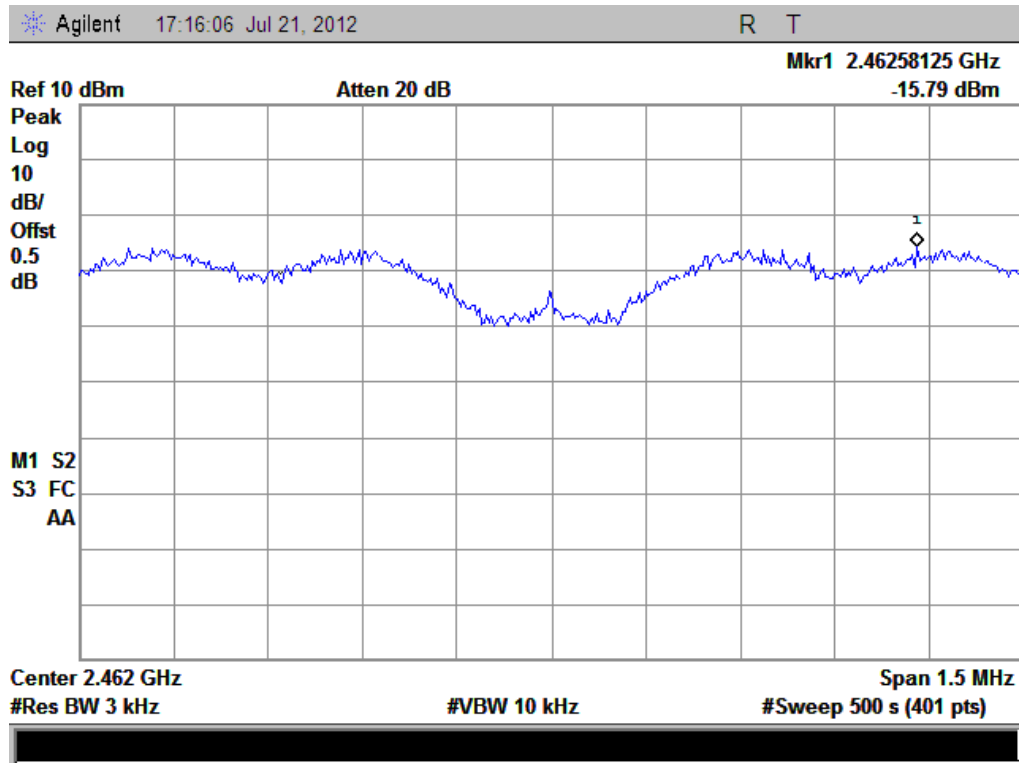

(CH High)

802.11n-20MHz Test Mode

| Channel | Frequency (MHz) | PSD (dBm) | Limits(dBm) | Result |
|---------|-----------------|-----------|-------------|--------|
| 1 | 2412 | -14.72 | ≤8 | PASS |
| 6 | 2437 | -16.08 | ≤8 | PASS |
| 11 | 2462 | -15.77 | ≤8 | PASS |

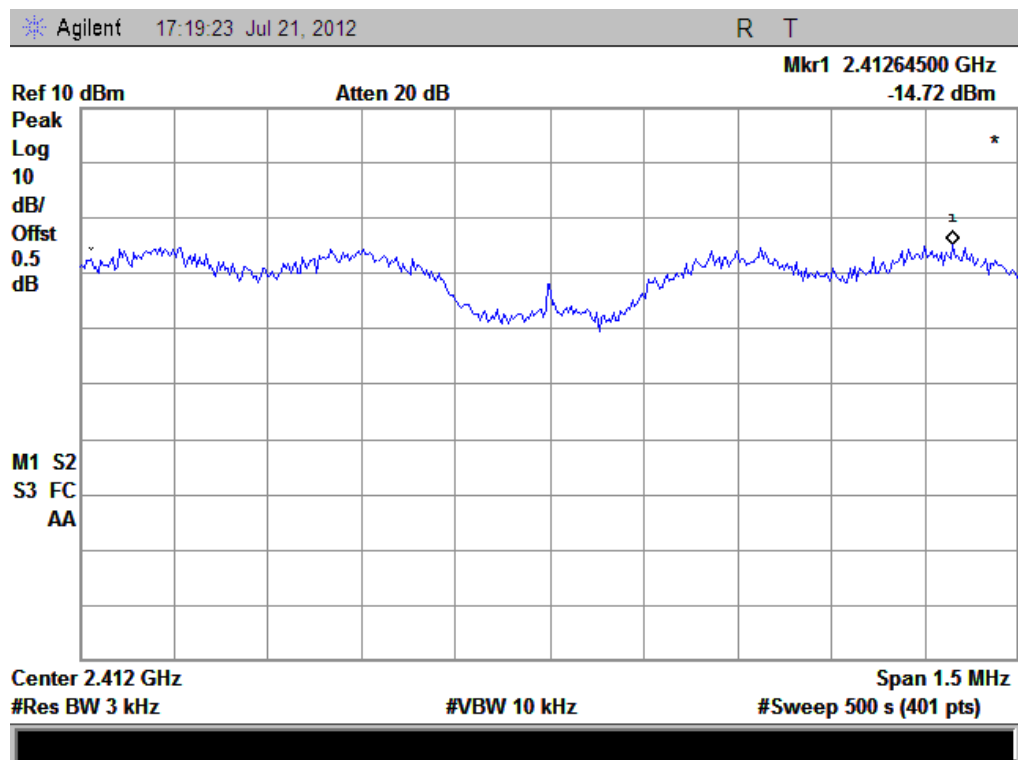

(CH Low)

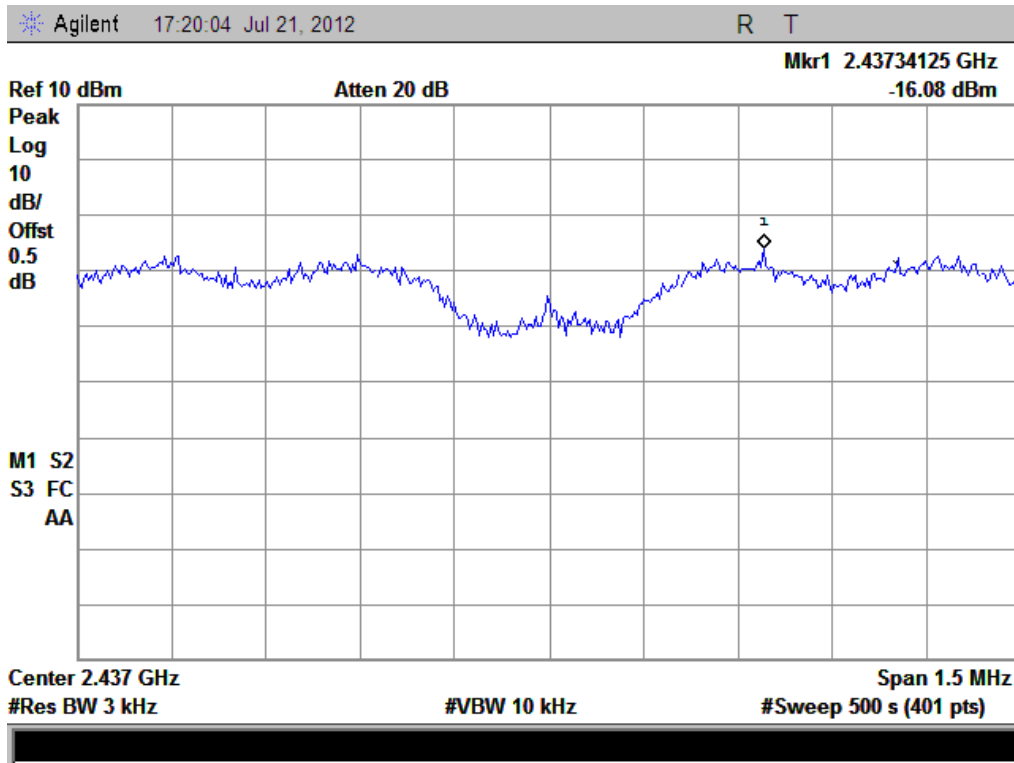

(CH Mid)

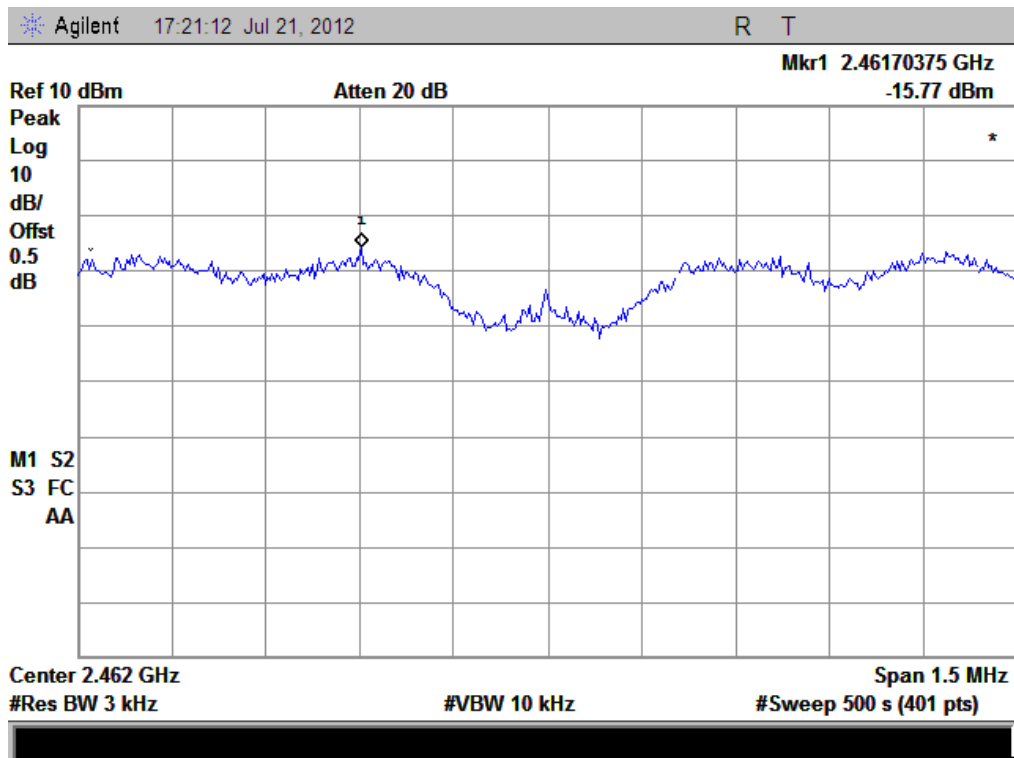

(CH High)

802.11n-40MHz Test Mode

| Channel | Frequency (MHz) | PSD (dBm) | Limits(dBm) | Result |
|---------|-----------------|-----------|-------------|--------|
| 3 | 2422 | -19.86 | ≤8 | PASS |
| 6 | 2437 | -17.35 | ≤8 | PASS |
| 9 | 2452 | -18.44 | ≤8 | PASS |

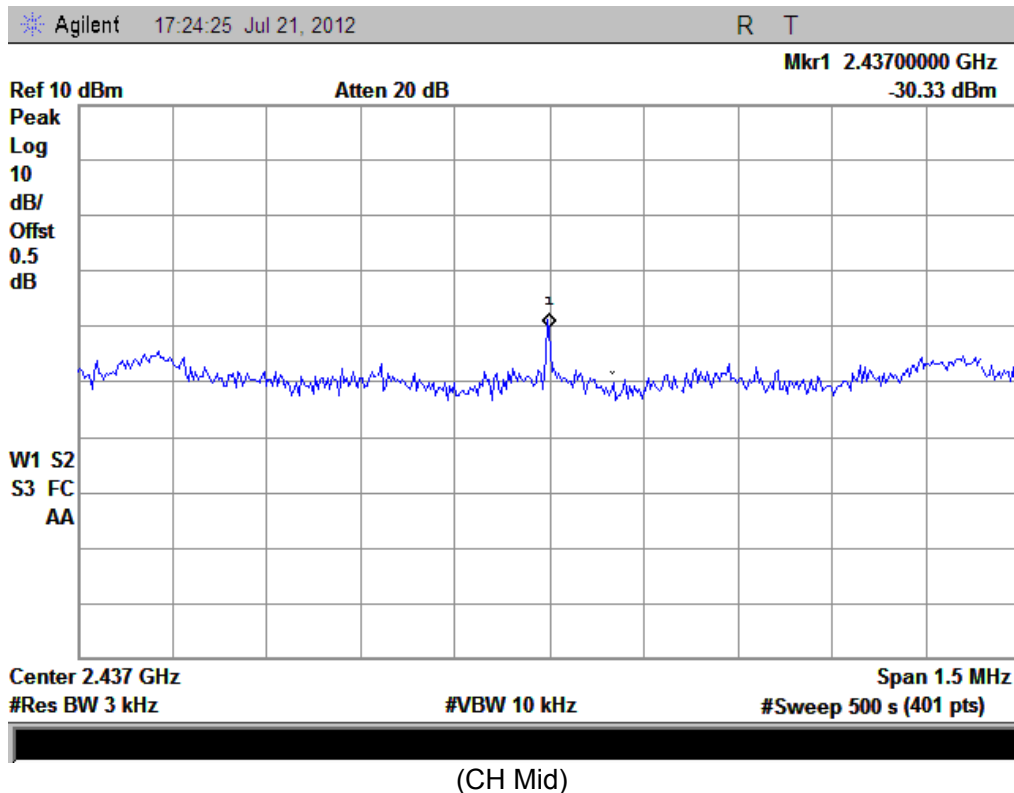
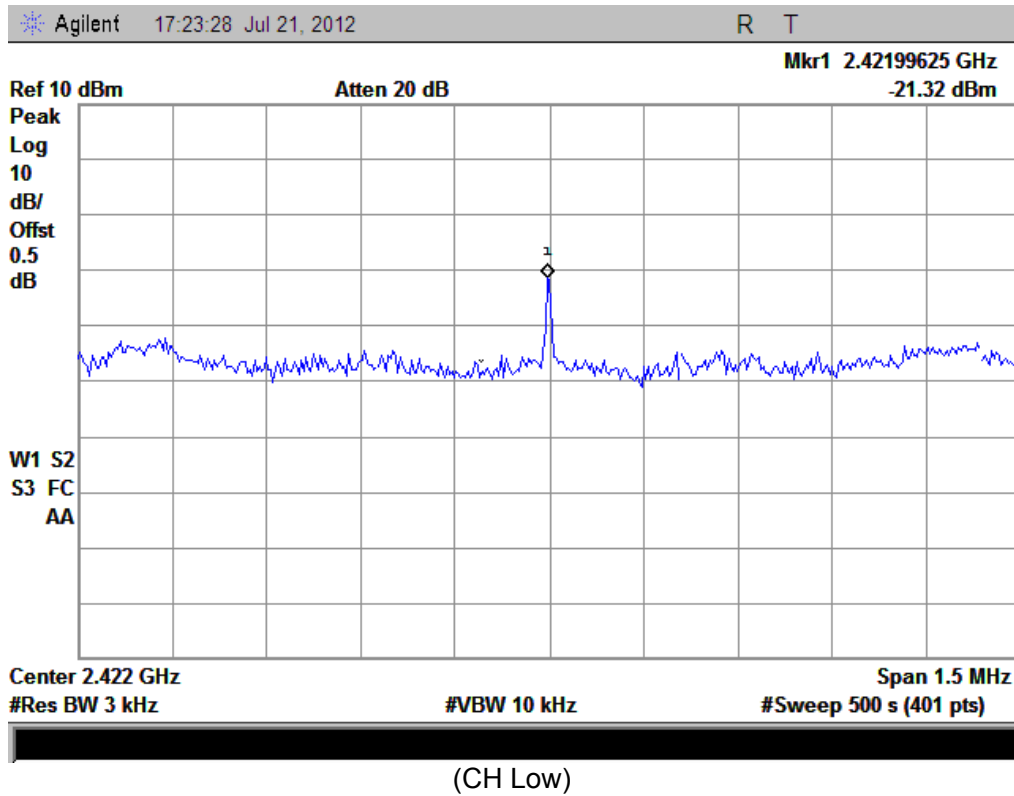

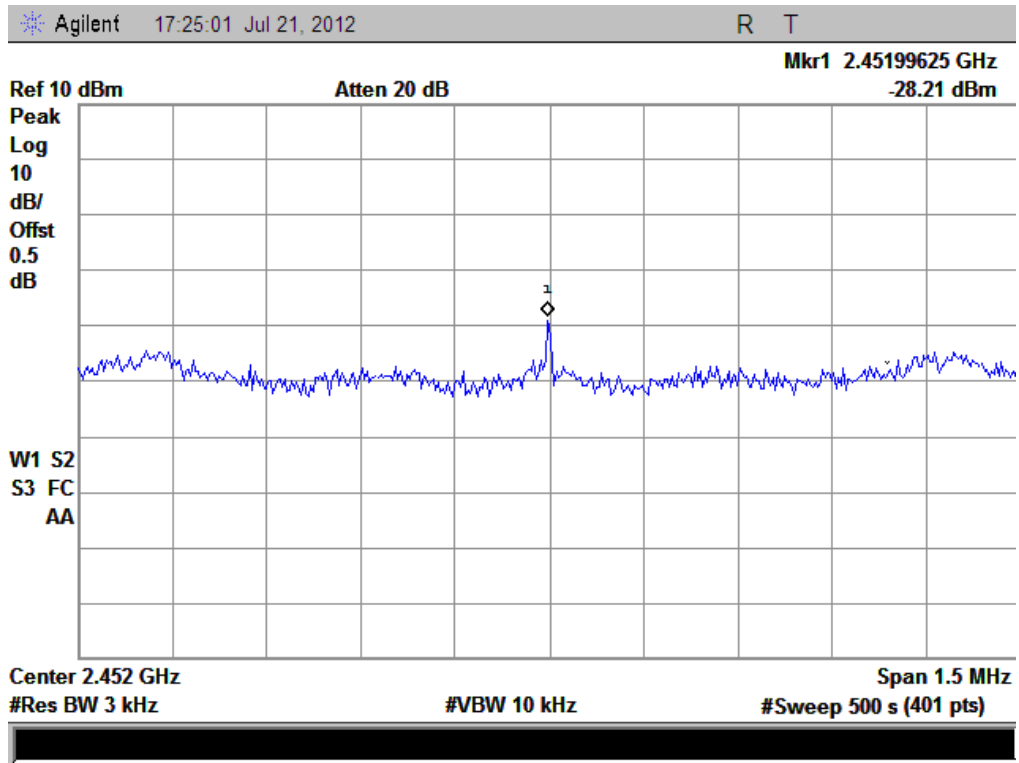

(CH High)

5.6 Conducted Emission

5.6.1 Definition

According to FCC section 15.207, for an intentional radiator that is designed to be connected to the public utility (AC) power line, the radio frequency voltage that is conducted back onto the AC power line on any frequency or frequencies, within the band 150 kHz to 30 MHz, shall not exceed the limits in the following table, as measured using a 50 μ H/50 ohms line impedance stabilization network (LISN).

| Frequency | Maximum RF Line Voltage | |
|---------------|-------------------------|----------------|
| | Q.P.(dBuV) | Average(dBuV) |
| 150kHz-500kHz | 66-56 | 56-46 |
| 500kHz-5MHz | 56 | 46 |
| 5MHz-30MHz | 60 | 50 |

Note:

1. The lower limit shall apply at the transition frequency.
2. The limit decreases linearly with the logarithm of the frequency in the range 0.15 MHz to 0.50 MHz

5.6.2 Test Description

The EUT is powered by the Battery charged with the AC Adapter which is powered by 120V, 60Hz AC mains supply. The path loss as the factor is calibrated to correct the reading. During the measurement, the EUT is activated and is set to operate at maximum power.

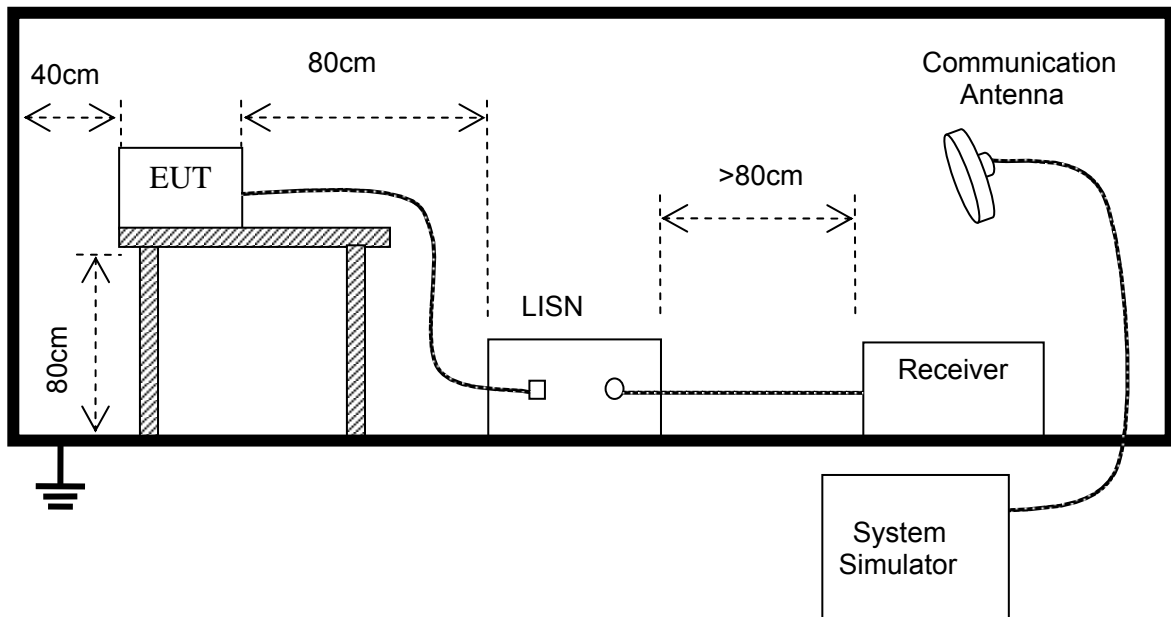

5.6.3 Test Result

Conducted Emission Measurement

File : PLUM Data : #7 Date: 2012-07-07 Time: 17:19:07

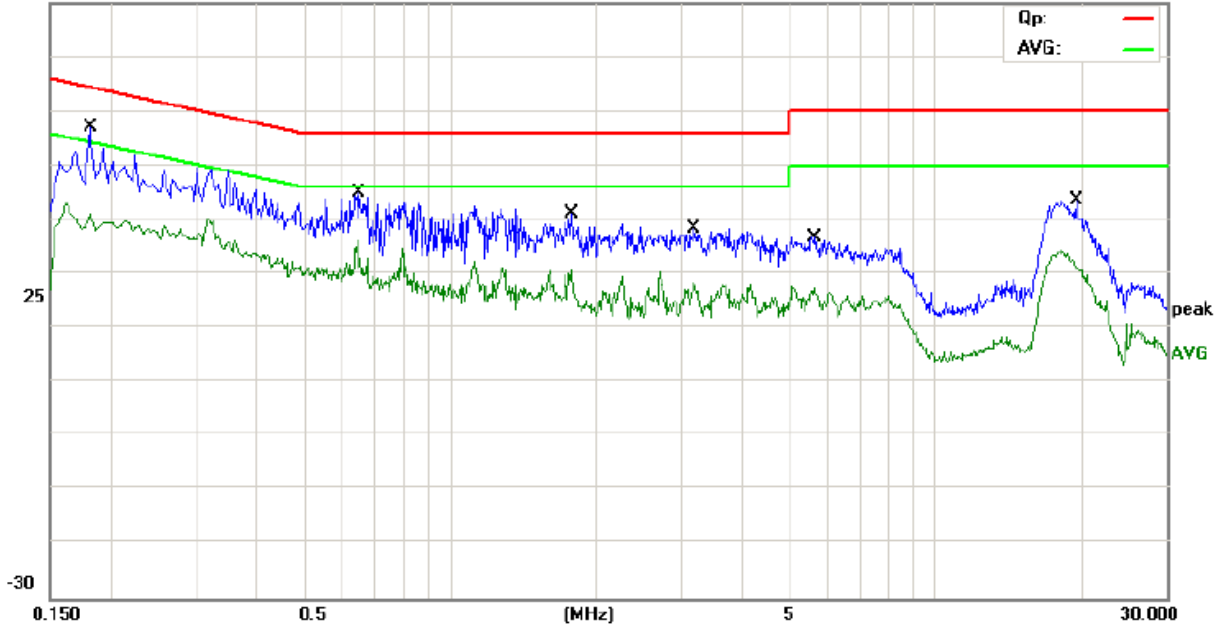

Site site #1 Phase: **L1** Temperature: 26
 Limit: FCC Part15 B Class B QP Power: 120V/60Hz Humidity: 60 %
 EUT: MOBILE PHONE
 M/N: Wicked
 Mode: wifi
 Note:

| No. | Mk. | Freq. MHz | Reading Level dBuV | Correct Factor dB | Measure- ment dBuV | Limit dBuV | Over dB | Detector | Comment |
|-----|-----|--------------|--------------------------|-------------------------|--------------------------|---------------|------------|----------|---------|
| 1 | * | 0.1820 | 46.21 | 10.92 | 57.13 | 64.39 | -7.26 | QP | |
| 2 | | 0.6540 | 34.82 | 10.00 | 44.82 | 56.00 | -11.18 | QP | |
| 3 | | 1.7820 | 31.94 | 9.22 | 41.16 | 56.00 | -14.84 | QP | |
| 4 | | 3.1940 | 28.27 | 10.19 | 38.46 | 56.00 | -17.54 | QP | |
| 5 | | 5.6660 | 25.13 | 11.60 | 36.73 | 60.00 | -23.27 | QP | |
| 6 | | 19.5340 | 34.55 | 9.00 | 43.55 | 60.00 | -16.45 | QP | |

*:Maximum data x:Over limit !:over margin

Conducted Emission Measurement

File :PLUM
80.0 dBuV

Data :#8

Date: 2012-07-07

Time: 17:20:15

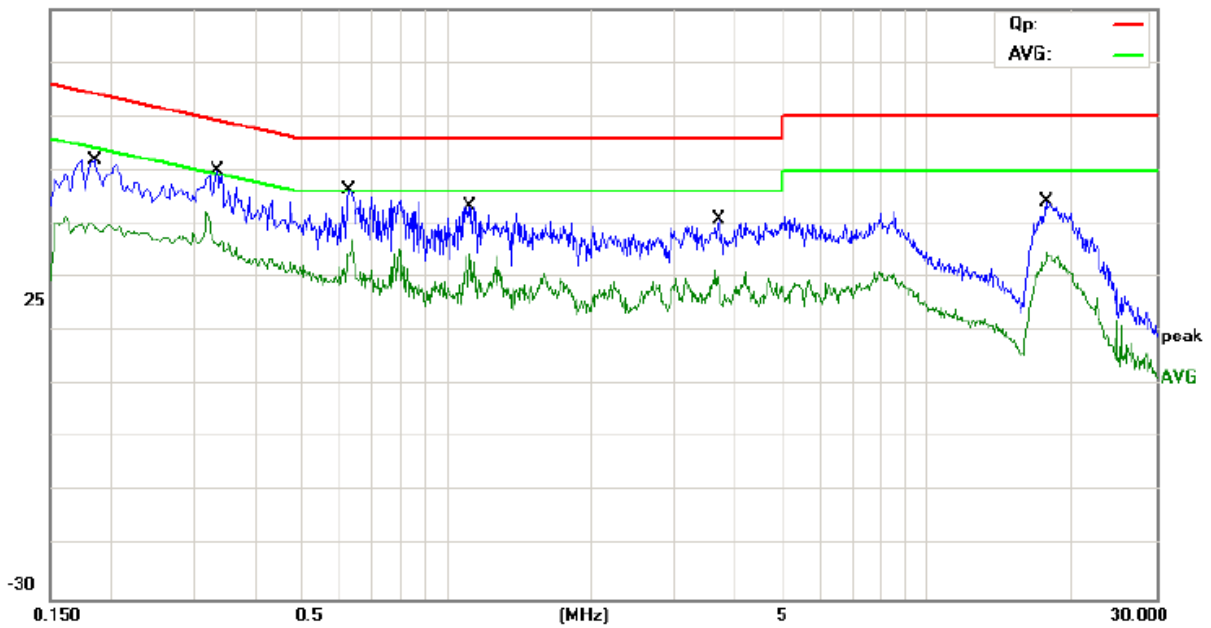

Site site #1

Phase: N

Temperature: 26

Limit: FCC Part15 B Class B QP

Power: 120V/60Hz

Humidity: 60 %

EUT: MOBILE PHONE

M/N: Wicked

Mode: wifi

Note:

| No. | Mk. | Freq. MHz | Reading Level dBuV | Correct Factor dB | Measure- ment dBuV | Limit dBuV | Over dB | Detector | Comment |
|-----|-----|--------------|--------------------------|-------------------------|--------------------------|---------------|------------|----------|---------|
| 1 | | 0.1860 | 40.77 | 11.16 | 51.93 | 64.21 | -12.28 | QP | |
| 2 | * | 0.3340 | 38.70 | 11.11 | 49.81 | 59.35 | -9.54 | QP | |
| 3 | | 0.6300 | 36.27 | 10.00 | 46.27 | 56.00 | -9.73 | QP | |
| 4 | | 1.1220 | 33.45 | 9.88 | 43.33 | 56.00 | -12.67 | QP | |
| 5 | | 3.6980 | 30.23 | 10.70 | 40.93 | 56.00 | -15.07 | QP | |
| 6 | | 17.6780 | 35.02 | 9.00 | 44.02 | 60.00 | -15.98 | QP | |

*:Maximum data x:Over limit !:over margin

5.7 Radiated Emission

5.7.1 Definition

According to FCC section 15.247(d), radiated emission outside the frequency band attenuation below the general limits specified in § 15.209(a) is not required. In addition, radiated emissions which fall in the restricted bands, as defined in § 15.205(a), must also comply with the radiated emission limits specified in § 15.209(a) (see § 15.205(c)).

According to FCC section 15.209 (a), except as provided elsewhere in this subpart, the emissions from an intentional radiator shall not exceed the field strength levels specified in the following table:

| Frequency (MHz) | Field Strength ($\mu\text{V}/\text{m}$) | Measurement Distance (m) |
|-----------------|-------------------------------------------|--------------------------|
| 0.009 - 0.490 | 2400/F(kHz) | 300 |
| 0.490 - 1.705 | 24000/F(kHz) | 30 |
| 1.705 - 30.0 | 30 | 30 |
| 30 - 88 | 100 | 3 |
| 88 - 216 | 150 | 3 |
| 216 - 960 | 200 | 3 |
| Above 960 | 500 | 3 |

As shown in FCC section 15.35(b), for frequencies above 1000MHz, the field strength limits are based on average detector. When average radiated emission measurements are specified in this part, including emission measurements below 1000MHz, there also is a limit on the radio frequency emissions, as measured using instrumentation with a peak detector function, corresponding to 20dB above the maximum permitted average limit for the frequency being investigated unless a different peak emission limit is otherwise specified in the rules.

5.7.2 Test Description

A. Test Setup:

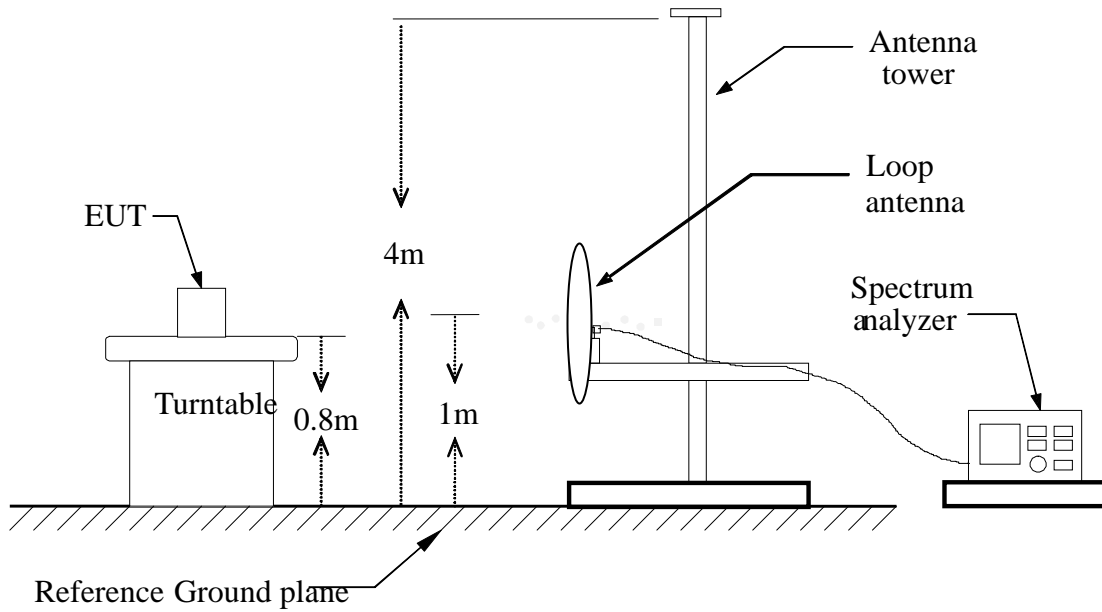

Blow 1GHz:

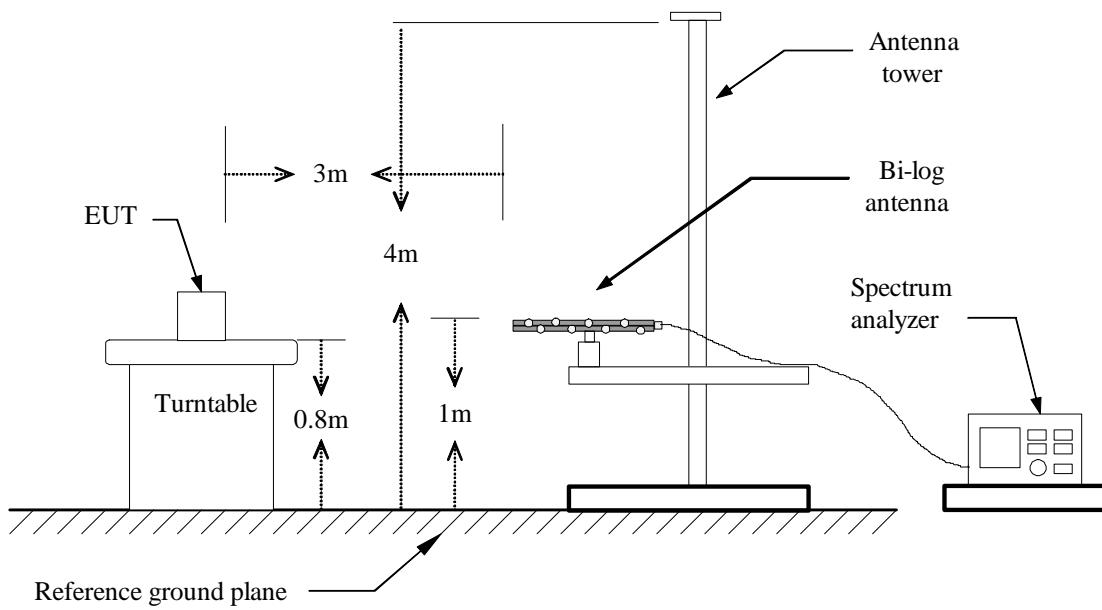

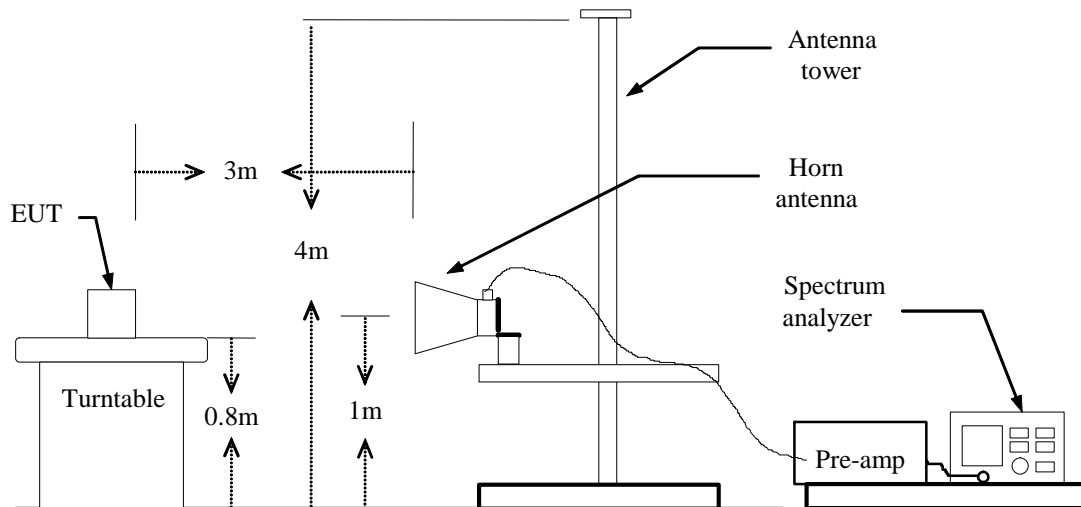
Above 1GHz:**B. Test procedures**

1. The EUT is placed on a turntable, which is 0.8m above ground plane.
2. The turntable shall be rotated for 360 degrees to determine the position of maximum emission level.
3. EUT is set 3m away from the receiving antenna, which is varied from 1m to 4m to find out the highest emissions.
4. Maximum procedure was performed on the six highest emissions to ensure EUT compliance.
5. And also, each emission was to be maximized by changing the polarization of receiving antenna both horizontal and vertical.
6. Set the spectrum analyzer in the following setting as:
 - Below 1GHz: RBW=100 kHz / VBW=300 kHz / Sweep=AUTO
 - Above 1GHz : (a) PEAK: RBW=VBW=1MHz / Sweep=AUTO
 - (b) AVERAGE: RBW=1MHz / VBW=1MHz / Sweep=AUTO
7. Repeat above procedures until the measurements for all frequencies are complete.

5.7.3 Test Result

Form 9 KHz to 30MHz:

| Freq. (MHz) | Ant. Pol H/V | Peak Reading (dBuV) | Ant. / CL CF (dB) | Actual Fs Peak (dBuV/m) | Peak Limit (dBuV/m) | Peak Margin (dB) |
|----------------|-----------------|---------------------------|-------------------------|-------------------------------|---------------------------|------------------------|
| | H | | | | | |
| | H | | | | | |
| | H | | | | | |
| N/A | | | | | | >20 |
| | V | | | | | |
| | V | | | | | |
| | V | | | | | |
| N/A | | | | | | >20 |

-Note: No test data was detected in below 30MHz.

Below 1 GHz

Radiated Emission Measurement

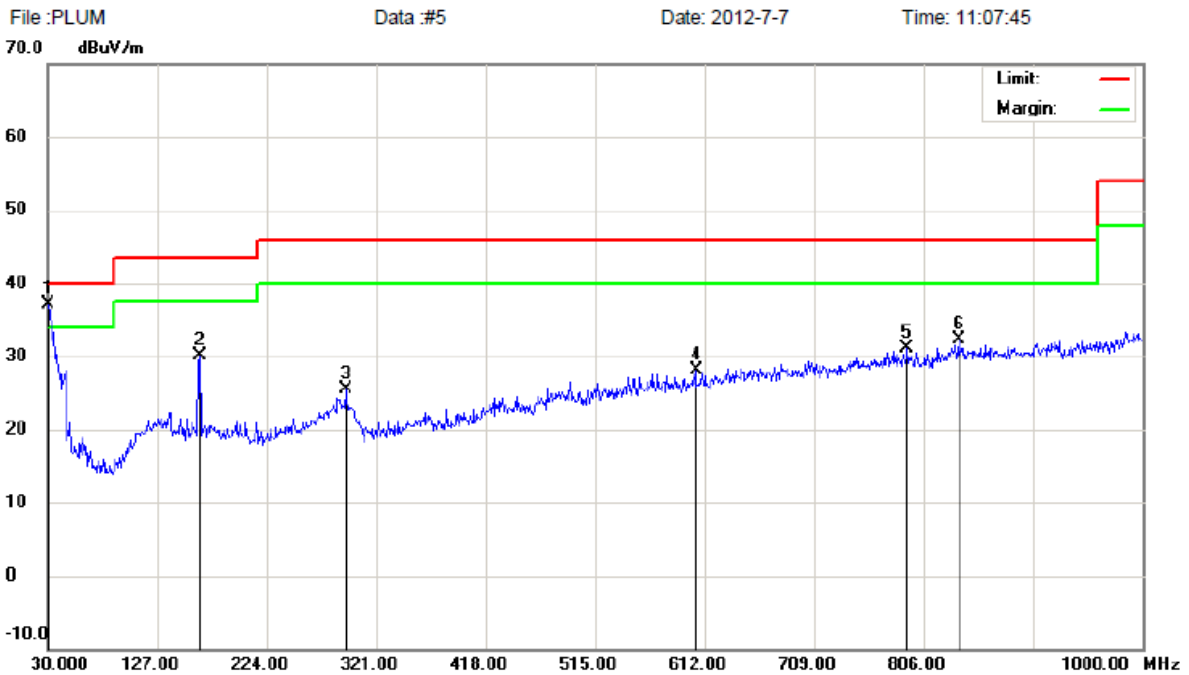

Site site MOST 3M Polarization: *Vertical* Temperature: 26
 Limit: FCC Part15 B 3M Radiation Power: AC 120V/60Hz Humidity: 61 %
 EUT: Phone Distance:
 M/N: Wicked
 Mode: WIFI
 Note:

| No. | Mk. | Freq. MHz | Reading Level dBuV | Correct Factor dB | Measure- ment dBuV/m | Limit dBuV/m | Over dB | Antenna Height cm | Table Degree | Detector | Comment |
|-----|-----|--------------|--------------------------|-------------------------|----------------------------|-----------------|------------|-------------------------|-----------------|----------|---------|
| 1 | * | 30.9700 | 13.07 | 24.05 | 37.12 | 40.00 | -2.88 | | | QP | |
| 2 | | 164.8300 | 12.91 | 17.21 | 30.12 | 43.50 | -13.38 | | | QP | |
| 3 | | 293.8400 | 6.18 | 19.32 | 25.50 | 46.00 | -20.50 | | | QP | |
| 4 | | 604.2400 | 4.94 | 23.17 | 28.11 | 46.00 | -17.89 | | | QP | |
| 5 | | 791.4500 | 5.11 | 25.98 | 31.09 | 46.00 | -14.91 | | | QP | |
| 6 | | 837.0400 | 5.23 | 27.10 | 32.33 | 46.00 | -13.67 | | | QP | |

*:Maximum data x:Over limit !:over margin

Radiated Emission Measurement

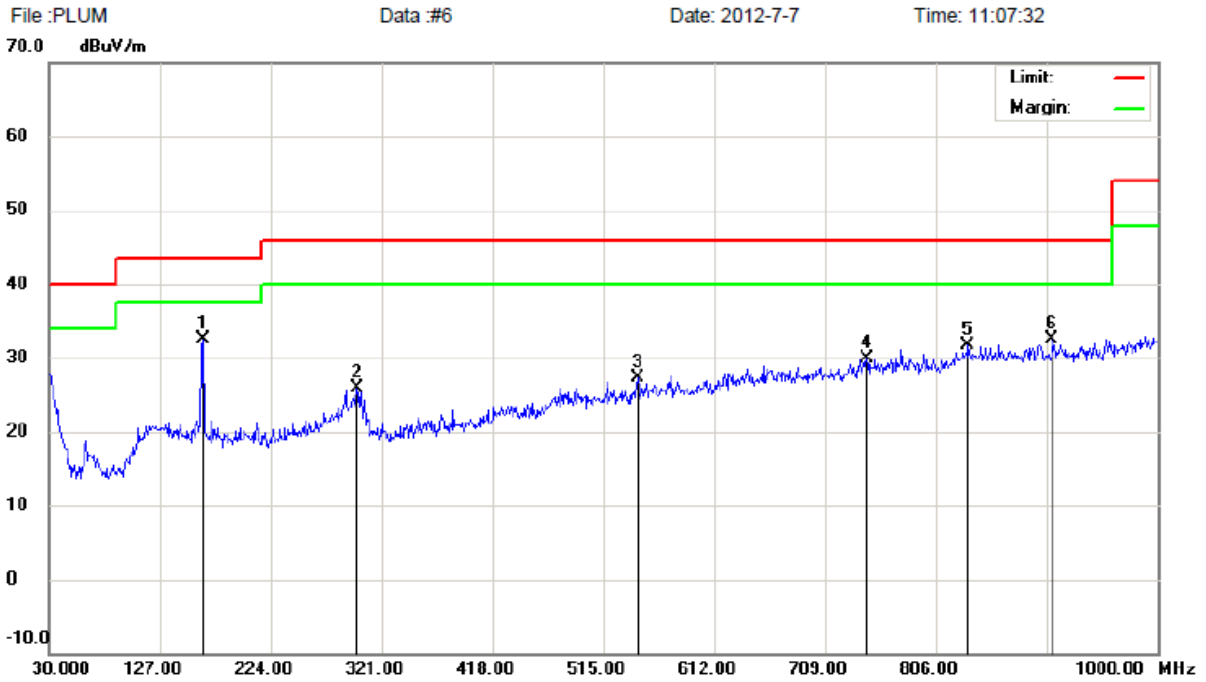

Site: site MOST 3M Polarization: **Horizontal** Temperature: 26
 Limit: FCC Part15 B 3M Radiation Power: AC 120V/60Hz Humidity: 61 %
 EUT: Phone Distance:
 M/N: Wicked
 Mode: WIFI
 Note:

| No. | Mk. | Freq. MHz | Reading Level dBuV | Correct Factor dB | Measure- ment dBuV/m | Limit dBuV/m | Over dB | Antenna Height cm | Table Degree | Comment |
|-----|-----|--------------|--------------------------|-------------------------|----------------------------|-----------------|------------|-------------------------|-----------------|---------|
| 1 | * | 164.8300 | 15.27 | 17.21 | 32.48 | 43.50 | -11.02 | QP | | |
| 2 | | 299.6600 | 6.60 | 19.30 | 25.90 | 46.00 | -20.10 | QP | | |
| 3 | | 545.0700 | 4.93 | 22.30 | 27.23 | 46.00 | -18.77 | QP | | |
| 4 | | 745.8600 | 4.02 | 25.80 | 29.82 | 46.00 | -16.18 | QP | | |
| 5 | | 834.1300 | 4.61 | 27.08 | 31.69 | 46.00 | -14.31 | QP | | |
| 6 | | 907.8500 | 5.04 | 27.56 | 32.60 | 46.00 | -13.40 | QP | | |

*:Maximum data x:Over limit !:over margin

Above 1 GHz

Operation Mode: TX/ IEEE 802.11b/CH Low **Test Date:** 2012-06-13
Temperature: 20°C **Humidity:** 70 % RH

| Freq. (MHz) | Ant. Pol H/V | Peak | AV | Ant. / CL | Actual Fs | | Peak | AV | AV |
|----------------|-----------------|---------|---------|--------------|-----------|--------|--------|--------|--------|
| | | Reading | Reading | CF | Peak | AV | Limit | Limit | Margin |
| | | dBuV | dBuV | dB | dBuV/m | dBuV/m | dBuV/m | dBuV/m | dB |
| 4824.5 | V | 46.08 | 25.48 | 23.05 | 69.13 | 48.53 | 74.00 | 54.00 | -5.47 |
| N/A | H | | | | | | | | |
| | | | | | | | | | |
| | | | | | | | | | |
| | | | | | | | | | |
| 4824.5 | H | 42.24 | 24.29 | 23.05 | 65.29 | 47.34 | 74.00 | 54.00 | -6.66 |
| N/A | H | | | | | | | | |
| | | | | | | | | | |
| | | | | | | | | | |

Notes:

1. Measuring frequencies from 1 GHz to the 10th harmonic of highest fundamental frequency.
2. Radiated emissions measured in frequency above 1000MHz were made with an instrument using peak/average detector mode.
3. Average test would be performed if the peak result were greater than the average limit or as required by the applicant.
4. Data of measurement within this frequency range shown " --- " in the table above means the reading of emissions are attenuated more than 20dB below the permissible limits or the field strength is too small to be measured.
5. Measurements above show only up to 6 maximum emissions noted, or would be lesser, with " N/A " remark, if no specific emissions from the EUT are recorded (ie: margin>20dB from the applicable limit) and considered that's already beyond the background noise floor.
6. Margin (dB) = Remark result (dBuV/m) – Average limit (dBuV/m).

Operation Mode: TX/ IEEE 802.11b/CH Mid **Test Date:** 2012-06-13
Temperature: 20°C **Humidity:** 70 % RH

| Freq. (MHz) | Ant. Pol H/V | Peak Reading dBuV | AV Reading dBuV | Ant. / CL CF dB | Actual Fs | | Peak Limit dBuV/m | AV Limit dBuV/m | AV Margin dB |
|----------------|-----------------|-------------------------|-----------------------|--------------------------|----------------|--------------|-------------------------|-----------------------|--------------------|
| | | | | | Peak dBuV/m | AV dBuV/m | | | |
| 4874.50 | V | 44.18 | 23.03 | 23.98 | 68.16 | 47.01 | 74.00 | 54.00 | -6.99 |
| N/A | V | | | | | | | | |
| | | | | | | | | | |
| | | | | | | | | | |
| 4874.50 | H | 45.36 | 22.78 | 23.98 | 69.34 | 46.76 | 74.00 | 54.00 | -7.24 |
| N/A | H | | | | | | | | |
| | | | | | | | | | |
| | | | | | | | | | |

Notes:

1. Measuring frequencies from 1 GHz to the 10th harmonic of highest fundamental frequency.
2. Radiated emissions measured in frequency above 1000MHz were made with an instrument using peak/average detector mode.
3. Average test would be performed if the peak result were greater than the average limit or as required by the applicant.
4. Data of measurement within this frequency range shown “ --- ” in the table above means the reading of emissions are attenuated more than 20dB below the permissible limits or the field strength is too small to be measured.
5. Measurements above show only up to 6 maximum emissions noted, or would be lesser, with “ N/A ” remark, if no specific emissions from the EUT are recorded (ie: margin>20dB from the applicable limit) and considered that's already beyond the background noise floor.
6. Margin (dB) = Remark result (dBuV/m) – Average limit (dBuV/m).

Operation Mode: TX/ IEEE 802.11b/CH High **Test Date:** 2012-06-13
Temperature: 20°C **Humidity:** 70 % RH

| Freq. (MHz) | Ant. Pol H/V | Peak Reading dBuV | AV Reading dBuV | Ant. / CL CF dB | Actual Fs | | Peak Limit dBuV/m | AV Limit dBuV/m | AV Margin dB |
|----------------|-----------------|-------------------------|-----------------------|--------------------------|----------------|--------------|-------------------------|-----------------------|--------------------|
| | | | | | Peak dBuV/m | AV dBuV/m | | | |
| 4924.50 | V | 43.68 | 23.08 | 24.86 | 68.54 | 47.94 | 74.00 | 54.00 | -6.06 |
| N/A | V | | | | | | | | |
| | | | | | | | | | |
| | | | | | | | | | |
| 4924.50 | H | 42.53 | 20.45 | 24.86 | 67.39 | 45.31 | 74.00 | 54.00 | -8.69 |
| N/A | H | | | | | | | | |
| | | | | | | | | | |
| | | | | | | | | | |

Notes:

1. Measuring frequencies from 1 GHz to the 10th harmonic of highest fundamental frequency.
2. Radiated emissions measured in frequency above 1000MHz were made with an instrument using peak/average detector mode.
3. Average test would be performed if the peak result were greater than the average limit or as required by the applicant.
4. Data of measurement within this frequency range shown " --- " in the table above means the reading of emissions are attenuated more than 20dB below the permissible limits or the field strength is too small to be measured.
5. Measurements above show only up to 6 maximum emissions noted, or would be lesser, with " N/A " remark, if no specific emissions from the EUT are recorded (ie: margin>20dB from the applicable limit) and considered that's already beyond the background noise floor.
6. Margin (dB) = Remark result (dBuV/m) – Average limit (dBuV/m).

Operation Mode: TX/ IEEE 802.11g/CH Low **Test Date:** 2012-06-13
Temperature: 20°C **Humidity:** 70 % RH

| Freq. (MHz) | Ant. Pol H/V | Peak Reading dBuV | AV Reading dBuV | Ant. / CL CF dB) | Actual Fs | | Peak Limit dBuV/m | AV Limit dBuV/m | AV Margin dB |
|----------------|-----------------|-------------------------|-----------------------|---------------------------|----------------|--------------|-------------------------|-----------------------|--------------------|
| | | | | | Peak dBuV/m | AV dBuV/m | | | |
| 4824.5 | V | 45.14 | 26.28 | 23.05 | 68.19 | 49.33 | 74.00 | 54.00 | -4.67 |
| N/A | V | | | | | | | | |
| | | | | | | | | | |
| | | | | | | | | | |
| 4824.5 | H | 44.62 | 25.27 | 23.05 | 67.67 | 48.32 | 74.00 | 54.00 | -5.68 |
| N/A | H | | | | | | | | |
| | | | | | | | | | |
| | | | | | | | | | |

Notes:

1. Measuring frequencies from 1 GHz to the 10th harmonic of highest fundamental frequency.
2. Radiated emissions measured in frequency above 1000MHz were made with an instrument using peak/average detector mode.
3. Average test would be performed if the peak result were greater than the average limit or as required by the applicant.
4. Data of measurement within this frequency range shown " --- " in the table above means the reading of emissions are attenuated more than 20dB below the permissible limits or the field strength is too small to be measured.
5. Measurements above show only up to 6 maximum emissions noted, or would be lesser, with " N/A " remark, if no specific emissions from the EUT are recorded (ie: margin>20dB from the applicable limit) and considered that's already beyond the background noise floor.
6. Margin (dB) = Remark result (dBuV/m) – Average limit (dBuV/m).

Operation Mode: TX/ IEEE 802.11g/CH Mid **Test Date:** 2012-06-13
Temperature: 20°C **Humidity:** 70 % RH

| Freq. (MHz) | Ant. Pol H/V | Peak Reading dBuV | AV Reading dBuV | Ant. / CL CF dB) | Actual Fs | | Peak Limit dBuV/m | AV Limit dBuV/m | AV Margin dB |
|----------------|-----------------|-------------------------|-----------------------|---------------------------|----------------|--------------|-------------------------|-----------------------|--------------------|
| | | | | | Peak dBuV/m | AV dBuV/m | | | |
| 4874.50 | V | 45.36 | 24.67 | 23.98 | 69.34 | 48.65 | 74.00 | 54.00 | -5.35 |
| N/A | V | | | | | | | | |
| | | | | | | | | | |
| | | | | | | | | | |
| 4874.50 | H | 43.95 | 22.13 | 23.98 | 67.93 | 46.11 | 74.00 | 54.00 | -7.89 |
| N/A | H | | | | | | | | |
| | | | | | | | | | |
| | | | | | | | | | |

Notes:

1. Measuring frequencies from 1 GHz to the 10th harmonic of highest fundamental frequency.
2. Radiated emissions measured in frequency above 1000MHz were made with an instrument using peak/average detector mode.
3. Average test would be performed if the peak result were greater than the average limit or as required by the applicant.
4. Data of measurement within this frequency range shown “ --- ” in the table above means the reading of emissions are attenuated more than 20dB below the permissible limits or the field strength is too small to be measured.
5. Measurements above show only up to 6 maximum emissions noted, or would be lesser, with “ N/A ” remark, if no specific emissions from the EUT are recorded (ie: margin>20dB from the applicable limit) and considered that's already beyond the background noise floor.
6. Margin (dB) = Remark result (dBuV/m) – Average limit (dBuV/m).

Operation Mode: TX/ IEEE 802.11g/CH High **Test Date:** 2012-06-13
Temperature: 20°C **Humidity:** 70 % RH

| Freq. (MHz) | Ant. Pol H/V | Peak Reading dBuV | AV Reading dBuV | Ant. / CL CF dB) | Actual Fs | | Peak Limit dBuV/m | AV Limit dBuV/m | AV Margin dB |
|----------------|-----------------|-------------------------|-----------------------|---------------------------|----------------|--------------|-------------------------|-----------------------|--------------------|
| | | | | | Peak dBuV/m | AV dBuV/m | | | |
| 4924.50 | V | 44.28 | 24.11 | 24.86 | 69.14 | 48.97 | 74.00 | 54.00 | -5.03 |
| N/A | V | | | | | | | | |
| | | | | | | | | | |
| | | | | | | | | | |
| 4924.50 | H | 43.77 | 22.70 | 24.86 | 68.63 | 47.56 | 74.00 | 54.00 | -6.44 |
| N/A | H | | | | | | | | |
| | | | | | | | | | |
| | | | | | | | | | |

Notes:

1. Measuring frequencies from 1 GHz to the 10th harmonic of highest fundamental frequency.
2. Radiated emissions measured in frequency above 1000MHz were made with an instrument using peak/average detector mode.
3. Average test would be performed if the peak result were greater than the average limit or as required by the applicant.
4. Data of measurement within this frequency range shown “ --- ” in the table above means the reading of emissions are attenuated more than 20dB below the permissible limits or the field strength is too small to be measured.
5. Measurements above show only up to 6 maximum emissions noted, or would be lesser, with “ N/A ” remark, if no specific emissions from the EUT are recorded (ie: margin>20dB from the applicable limit) and considered that's already beyond the background noise floor.
6. Margin (dB) = Remark result (dBuV/m) – Average limit (dBuV/m).

Operation Mode: TX/ IEEE 802.11n/CH Low **Test Date:** 2012-06-13
Temperature: 20°C **Humidity:** 70 % RH

| Freq. (MHz) | Ant. Pol H/V | Peak Reading dBuV | AV Reading dBuV | Ant. / CL CF dB) | Actual Fs | | Peak Limit dBuV/m | AV Limit dBuV/m | AV Margin dB |
|----------------|-----------------|-------------------------|-----------------------|---------------------------|----------------|--------------|-------------------------|-----------------------|--------------------|
| | | | | | Peak dBuV/m | AV dBuV/m | | | |
| 4824.5 | V | 44.80 | 23.52 | 23.05 | 67.85 | 46.57 | 74.00 | 54.00 | -7.43 |
| N/A | V | | | | | | | | |
| | | | | | | | | | |
| | | | | | | | | | |
| 4824.5 | H | 44.48 | 22.24 | 23.05 | 67.53 | 45.29 | 74.00 | 54.00 | -8.71 |
| N/A | H | | | | | | | | |
| | | | | | | | | | |
| | | | | | | | | | |

Notes:

1. Measuring frequencies from 1 GHz to the 10th harmonic of highest fundamental frequency.
2. Radiated emissions measured in frequency above 1000MHz were made with an instrument using peak/average detector mode.
3. Average test would be performed if the peak result were greater than the average limit or as required by the applicant.
4. Data of measurement within this frequency range shown “ --- ” in the table above means the reading of emissions are attenuated more than 20dB below the permissible limits or the field strength is too small to be measured.
5. Measurements above show only up to 6 maximum emissions noted, or would be lesser, with “ N/A ” remark, if no specific emissions from the EUT are recorded (ie: margin>20dB from the applicable limit) and considered that's already beyond the background noise floor.
6. Margin (dB) = Remark result (dBuV/m) – Average limit (dBuV/m).

Operation Mode: TX/ IEEE 802.11n/CH Mid **Test Date:** 2012-06-13
Temperature: 20°C **Humidity:** 70 % RH

| Freq. (MHz) | Ant. Pol H/V | Peak Reading dBuV | AV Reading dBuV | Ant. / CL CF dB) | Actual Fs | | Peak Limit dBuV/m | AV Limit dBuV/m | AV Margin dB |
|----------------|-----------------|-------------------------|-----------------------|---------------------------|----------------|--------------|-------------------------|-----------------------|--------------------|
| | | | | | Peak dBuV/m | AV dBuV/m | | | |
| 4874.50 | V | 44.06 | 23.16 | 23.98 | 68.04 | 47.14 | 74.00 | 54.00 | -6.86 |
| N/A | V | | | | | | | | |
| | | | | | | | | | |
| | | | | | | | | | |
| 4874.50 | H | 43.85 | 22.49 | 23.98 | 67.83 | 46.47 | 74.00 | 54.00 | -7.53 |
| N/A | H | | | | | | | | |
| | | | | | | | | | |
| | | | | | | | | | |

Notes:

1. Measuring frequencies from 1 GHz to the 10th harmonic of highest fundamental frequency.
2. Radiated emissions measured in frequency above 1000MHz were made with an instrument using peak/average detector mode.
3. Average test would be performed if the peak result were greater than the average limit or as required by the applicant.
4. Data of measurement within this frequency range shown " --- " in the table above means the reading of emissions are attenuated more than 20dB below the permissible limits or the field strength is too small to be measured.
5. Measurements above show only up to 6 maximum emissions noted, or would be lesser, with " N/A " remark, if no specific emissions from the EUT are recorded (ie: margin>20dB from the applicable limit) and considered that's already beyond the background noise floor.
6. Margin (dB) = Remark result (dBuV/m) – Average limit (dBuV/m).

Operation Mode: TX/ IEEE 802.11n/CH High **Test Date:** 2012-06-13
Temperature: 20°C **Humidity:** 70 % RH

| Freq. (MHz) | Ant. Pol H/V | Peak Reading dBuV | AV Reading dBuV | Ant. / CL CF dB) | Actual Fs | | Peak Limit dBuV/m | AV Limit dBuV/m | AV Margin dB |
|----------------|-----------------|-------------------------|-----------------------|---------------------------|----------------|--------------|-------------------------|-----------------------|--------------------|
| | | | | | Peak dBuV/m | AV dBuV/m | | | |
| 4924.50 | V | 43.23 | 24.47 | 24.86 | 68.09 | 49.33 | 74.00 | 54.00 | -4.67 |
| N/A | V | | | | | | | | |
| | | | | | | | | | |
| | | | | | | | | | |
| 4924.50 | H | 42.63 | 22.32 | 24.86 | 67.49 | 47.18 | 74.00 | 54.00 | -6.82 |
| N/A | H | | | | | | | | |
| | | | | | | | | | |
| | | | | | | | | | |

Notes:

1. Measuring frequencies from 1 GHz to the 10th harmonic of highest fundamental frequency.
2. Radiated emissions measured in frequency above 1000MHz were made with an instrument using peak/average detector mode.
3. Average test would be performed if the peak result were greater than the average limit or as required by the applicant.
4. Data of measurement within this frequency range shown “ --- ” in the table above means the reading of emissions are attenuated more than 20dB below the permissible limits or the field strength is too small to be measured.
5. Measurements above show only up to 6 maximum emissions noted, or would be lesser, with “ N/A ” remark, if no specific emissions from the EUT are recorded (ie: margin>20dB from the applicable limit) and considered that's already beyond the background noise floor.
6. Margin (dB) = Remark result (dBuV/m) – Average limit (dBuV/m).

Test Range of "2.31GHz to 2.5GHz"

802.11b Test Mode

| Frequency (MHz) | Measured Level (dBuV) | Limit (dBuV) | Margin (dB) | Height (cm) | Azimuth (deg) | Polarization | Detector |
|-----------------|-----------------------|--------------|-------------|-------------|---------------|--------------|----------|
| 2390.00 | 52.02 | 74.00 | 21.98 | 100.00 | 256.00 | Vertical | Peak |
| | 43.11 | 54.00 | 10.89 | 100.00 | 152.00 | Horizontal | Average |
| 2483.50 | 50.01 | 74.00 | 23.99 | 100.00 | 120.00 | Vertical | Peak |
| | 42.21 | 54.00 | 11.79 | 100.00 | 120.00 | Horizontal | Average |

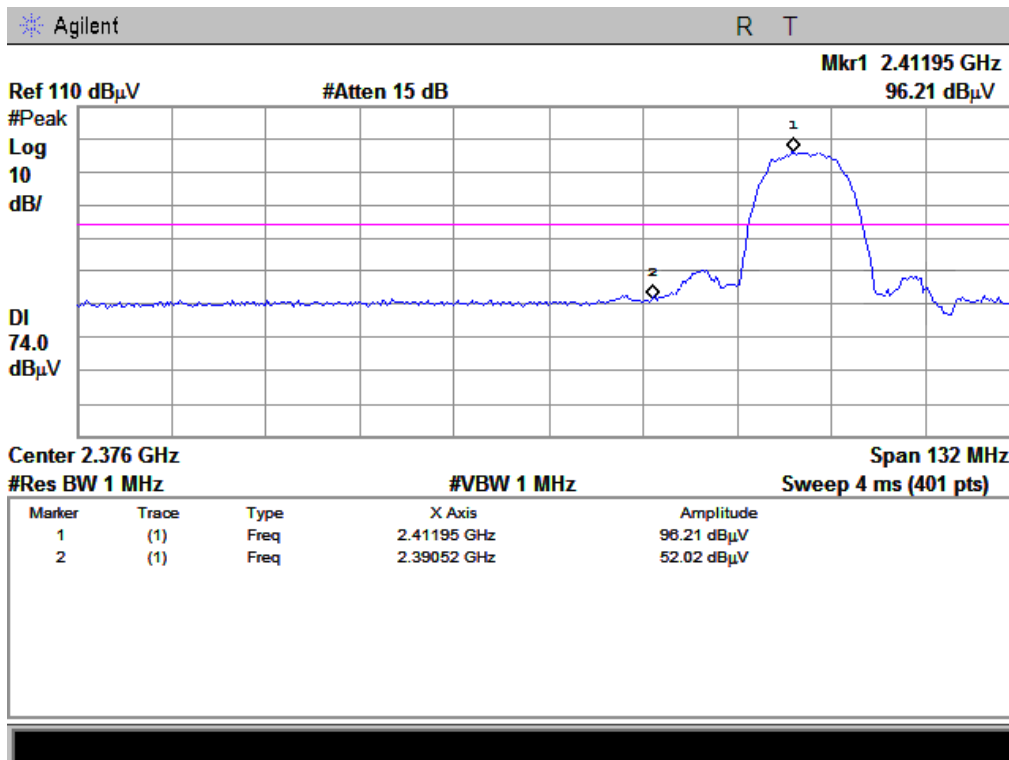

(CH Low, Peak)

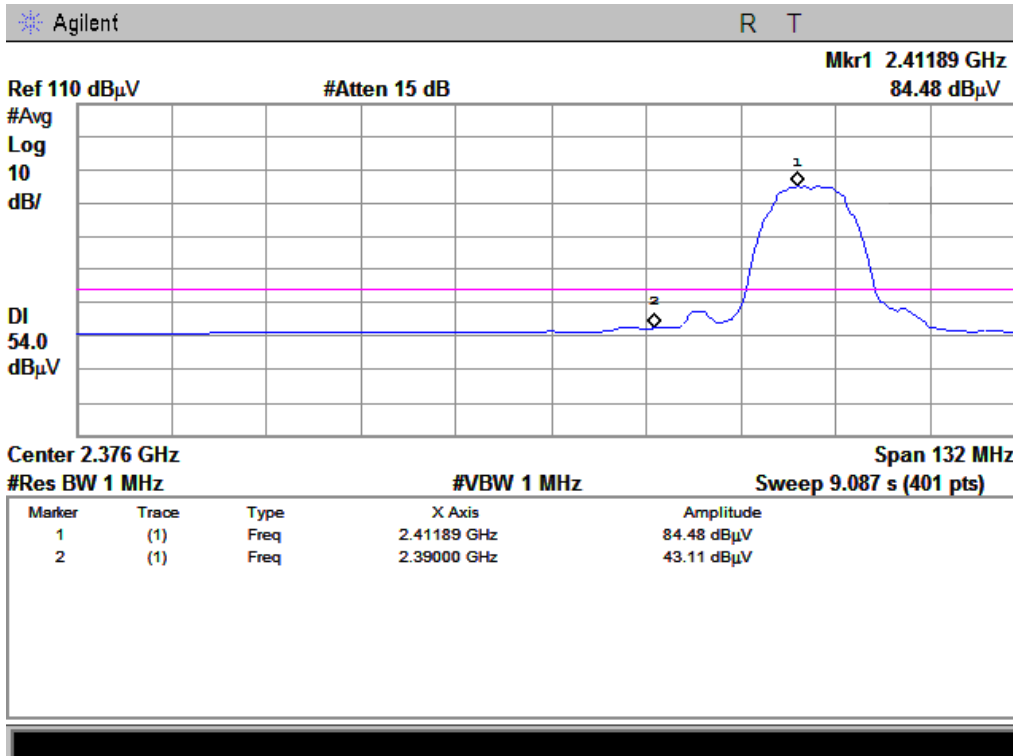

(CH Low, Average)

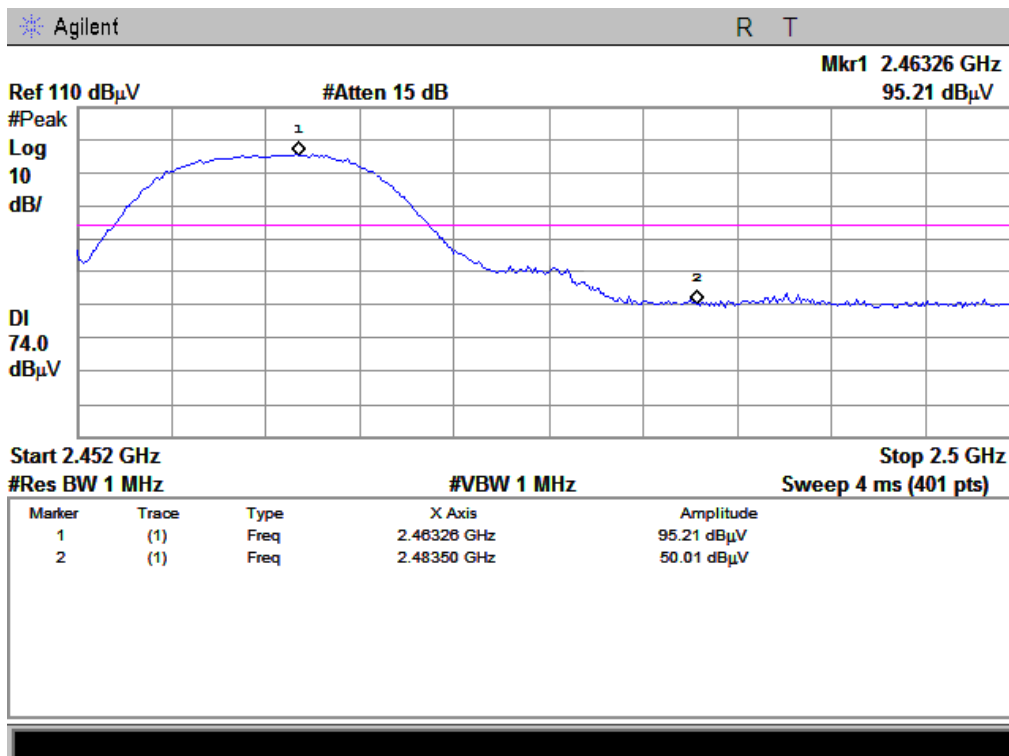

(CH High, Peak)

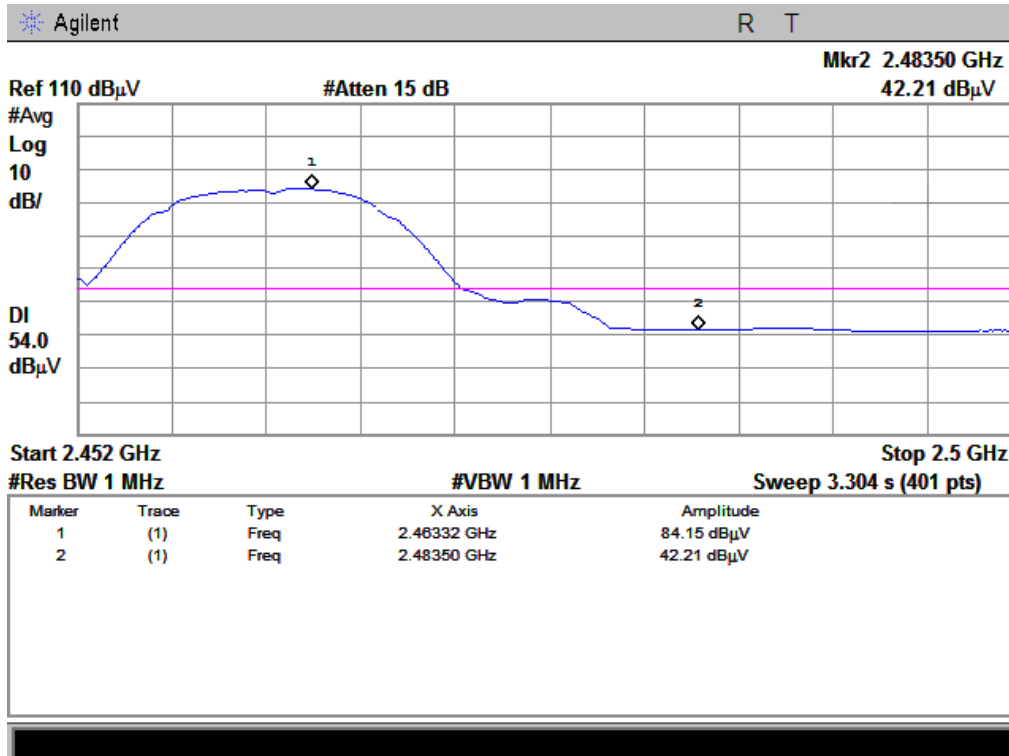

(CH High, Average)

802.11g Test Mode

| Frequency (MHz) | Measured Level (dBuV) | Limit (dBuV) | Margin (dB) | Height (cm) | Azimuth (deg) | Polarization | Detector |
|-----------------|-----------------------|--------------|-------------|-------------|---------------|--------------|----------|
| 2390.00 | 62.35 | 74.00 | 11.65 | 100.00 | 220.00 | Vertical | Peak |
| | 42.12 | 54.00 | 11.88 | 100.00 | 135.00 | Vertical | Average |
| 2483.50 | 61.26 | 74.00 | 12.74 | 200.00 | 330.00 | Horizontal | Peak |
| | 46.06 | 54.00 | 7.94 | 100.00 | 120.00 | Horizontal | Average |

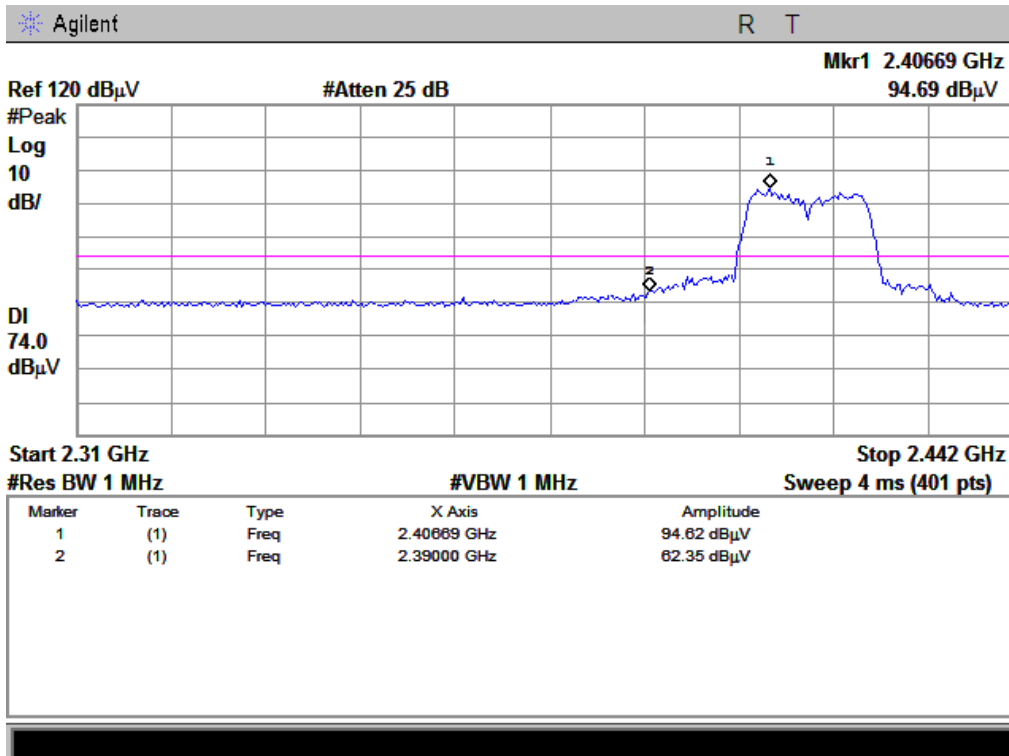

(CH Low, Peak)

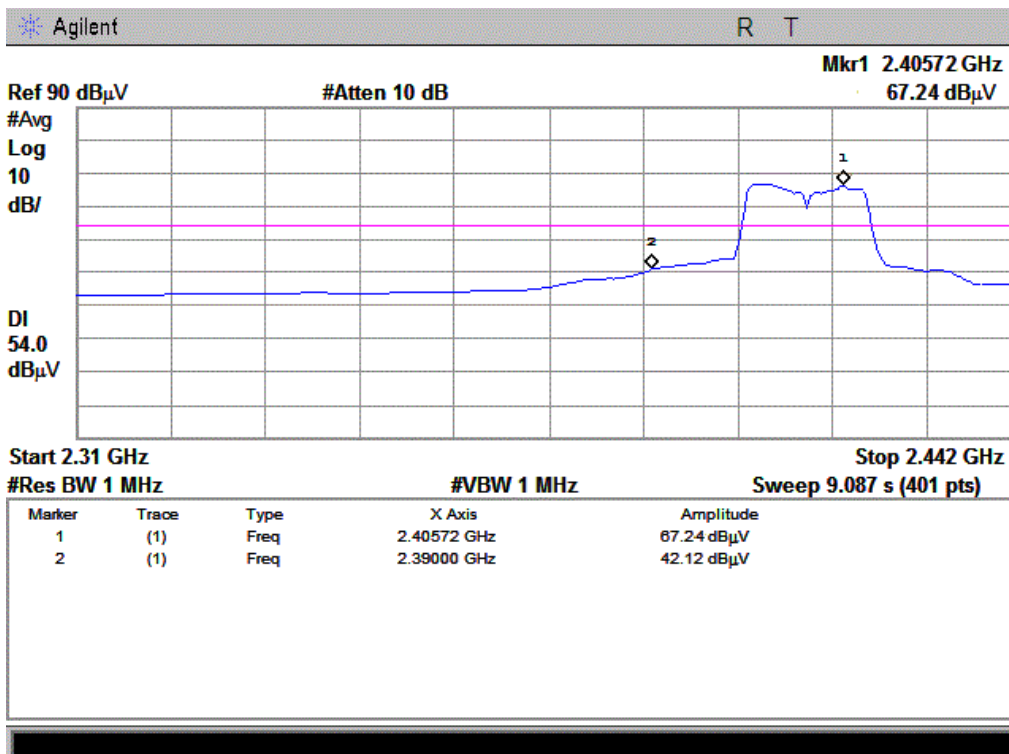

(CH Low, Average)

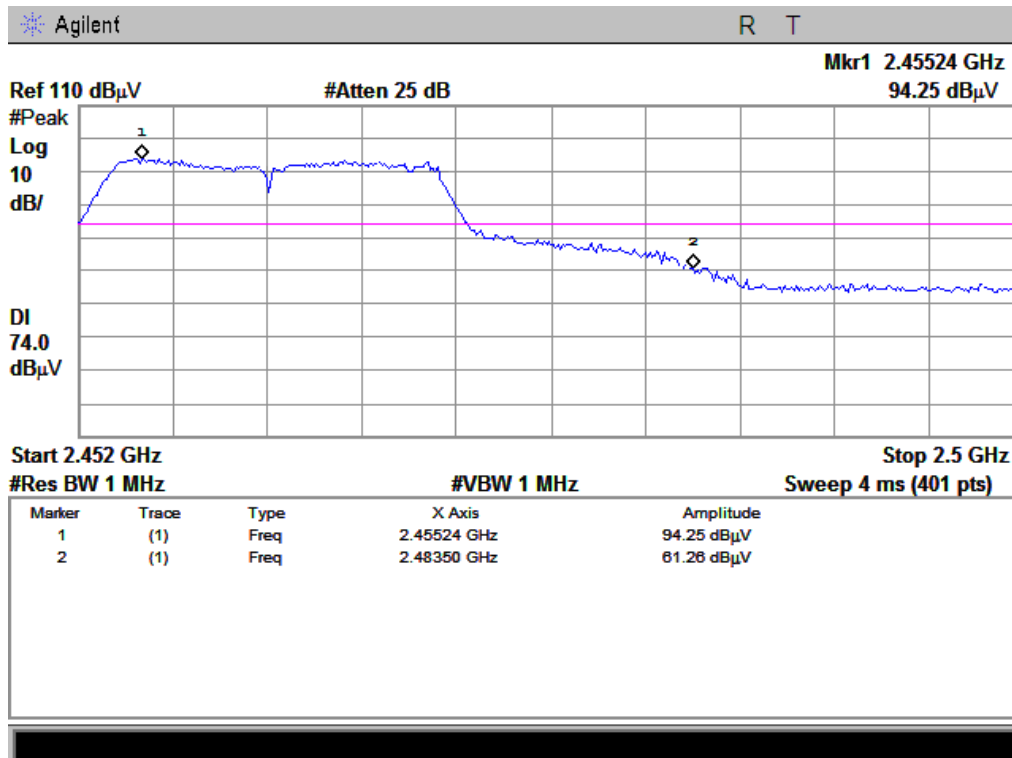

(CH High, Peak)

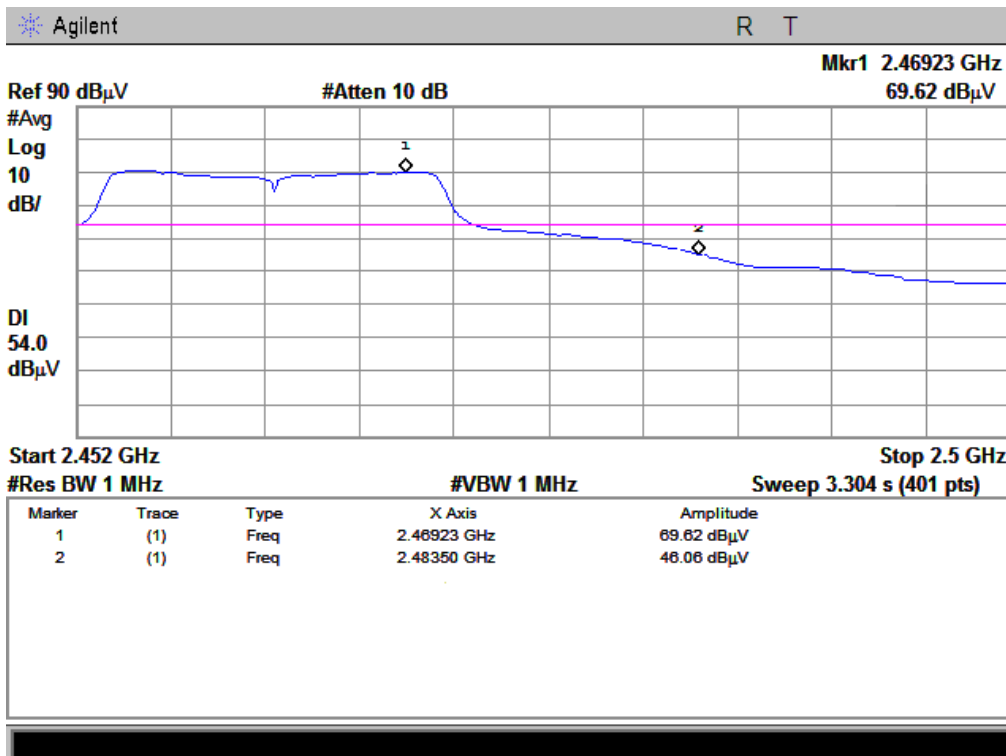

(CH High, Average)

802.11n-20MHz Test Mode

| Frequency (MHz) | Measured Level (dBuV) | Limit (dBuV) | Margin (dB) | Height (cm) | Azimuth (deg) | Polarization | Detector |
|-----------------|-----------------------|--------------|-------------|-------------|---------------|--------------|----------|
| 2390.00 | 65.33 | 74.00 | 8.67 | 200.00 | 245.00 | Vertical | Peak |
| | 44.90 | 54.00 | 9.10 | 100.00 | 135.00 | Horizontal | Average |
| 2483.50 | 61.38 | 74.00 | 12.62 | 100.00 | 95.00 | Vertical | Peak |
| | 44.23 | 54.00 | 9.77 | 100.00 | 120.00 | Horizontal | Average |

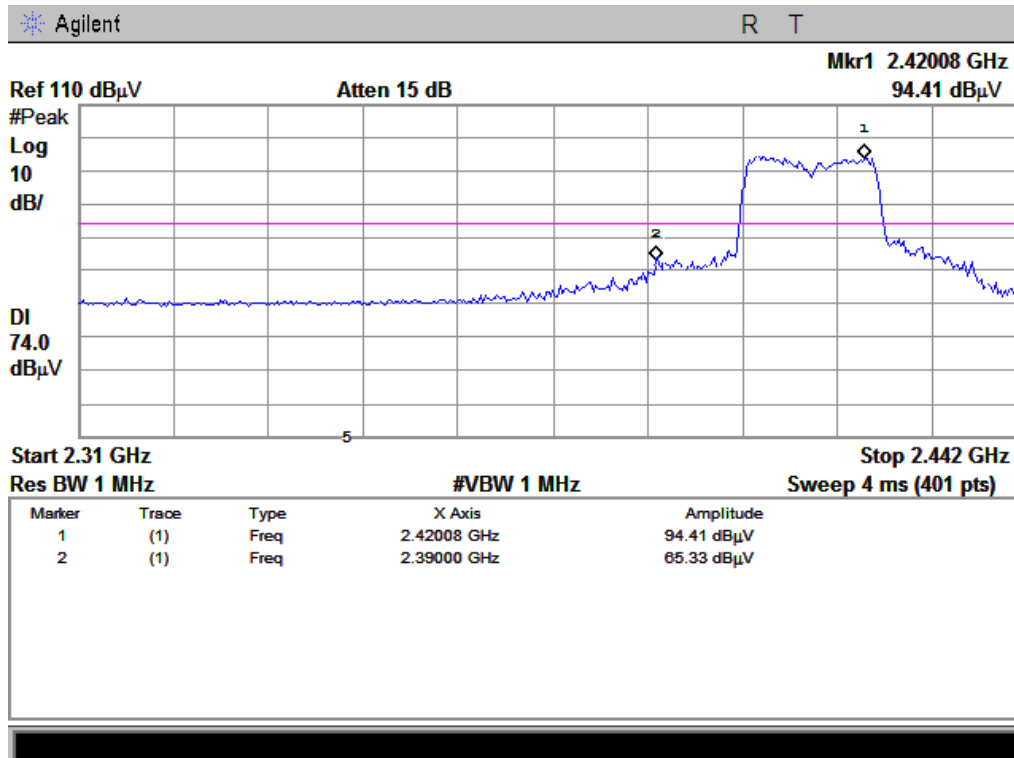

(CH Low, Peak)

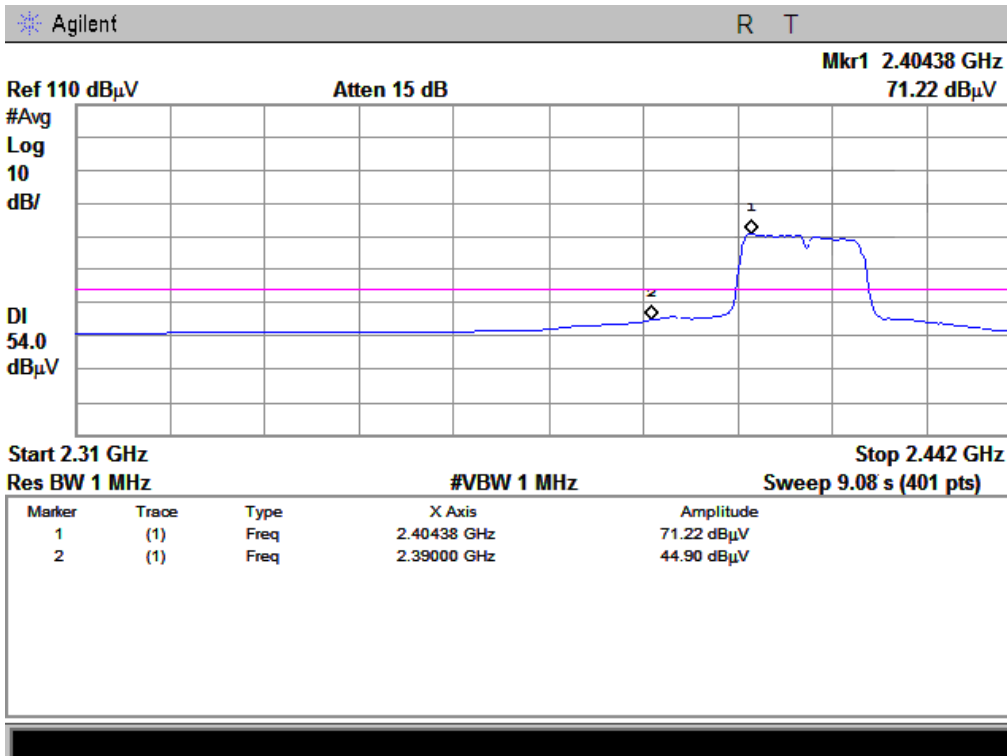

(CH Low, Average)

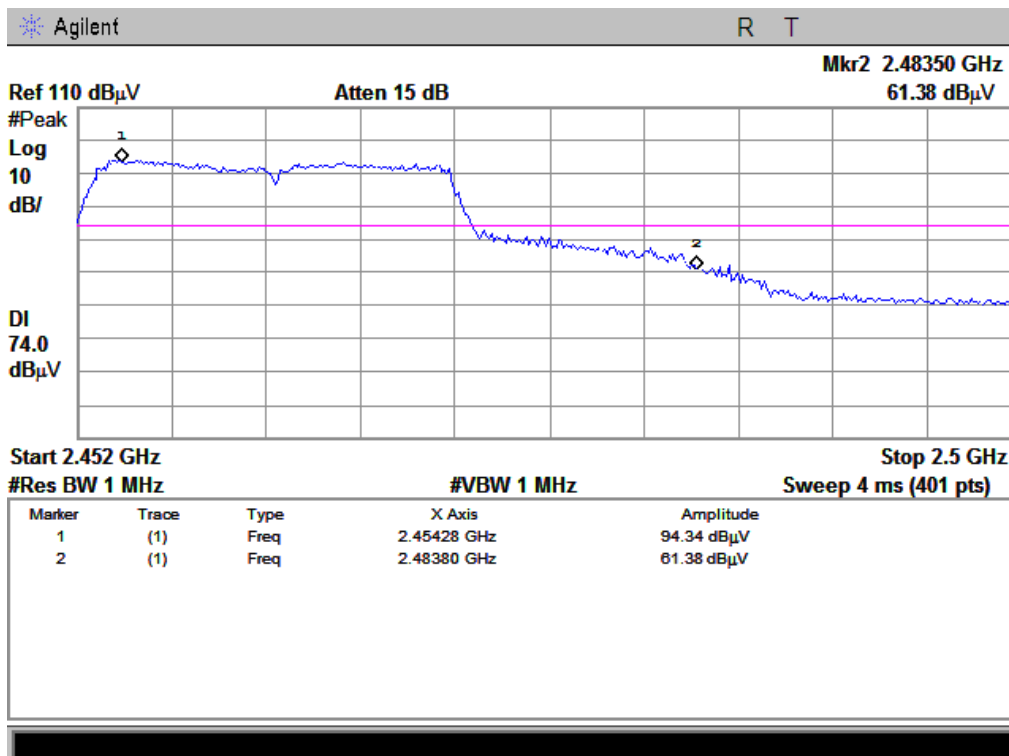

(CH High, Peak)

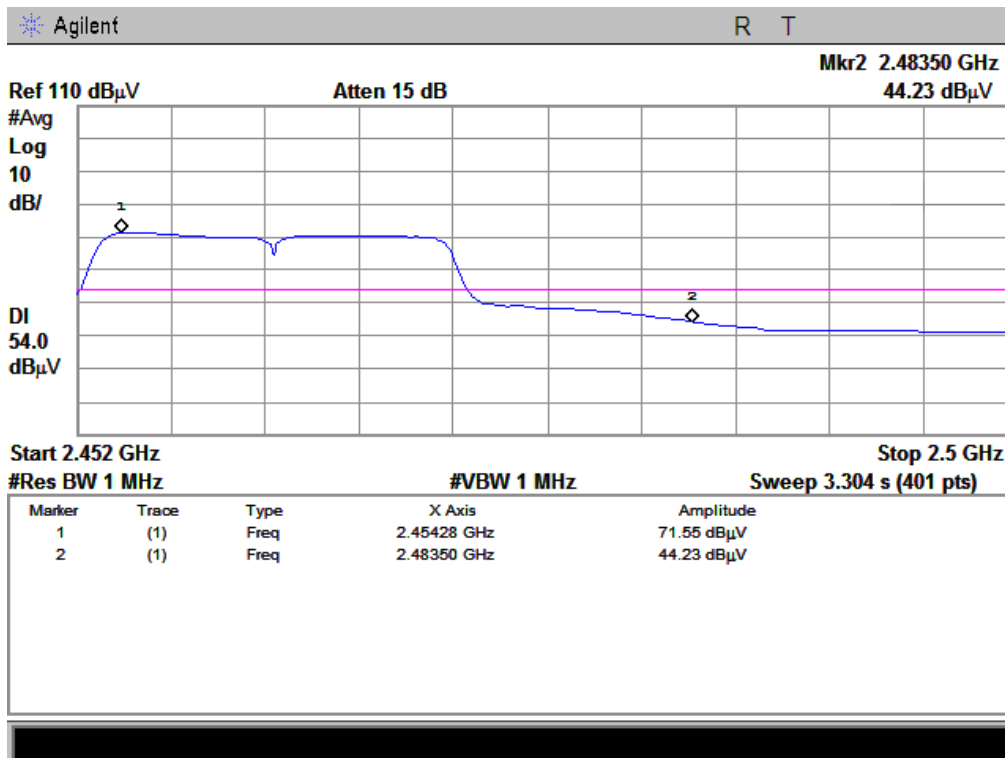

(CH High, Average)

802.11n-40MHz Test Mode

| Frequency (MHz) | Measured Level (dBuV) | Limit (dBuV) | Margin (dB) | Height (cm) | Azimuth (deg) | Polarization | Detector |
|-----------------|-----------------------|--------------|-------------|-------------|---------------|--------------|----------|
| 2390.00 | 59.95 | 74.00 | 14.05 | 100.00 | 225.00 | Vertical | Peak |
| | 43.25 | 54.00 | 10.75 | 100.00 | 145.00 | Horizontal | Average |
| 2483.50 | 63.49 | 74.00 | 10.51 | 200.00 | 120.00 | Vertical | Peak |
| | 40.56 | 54.00 | 13.44 | 100.00 | 120.00 | Horizontal | Average |

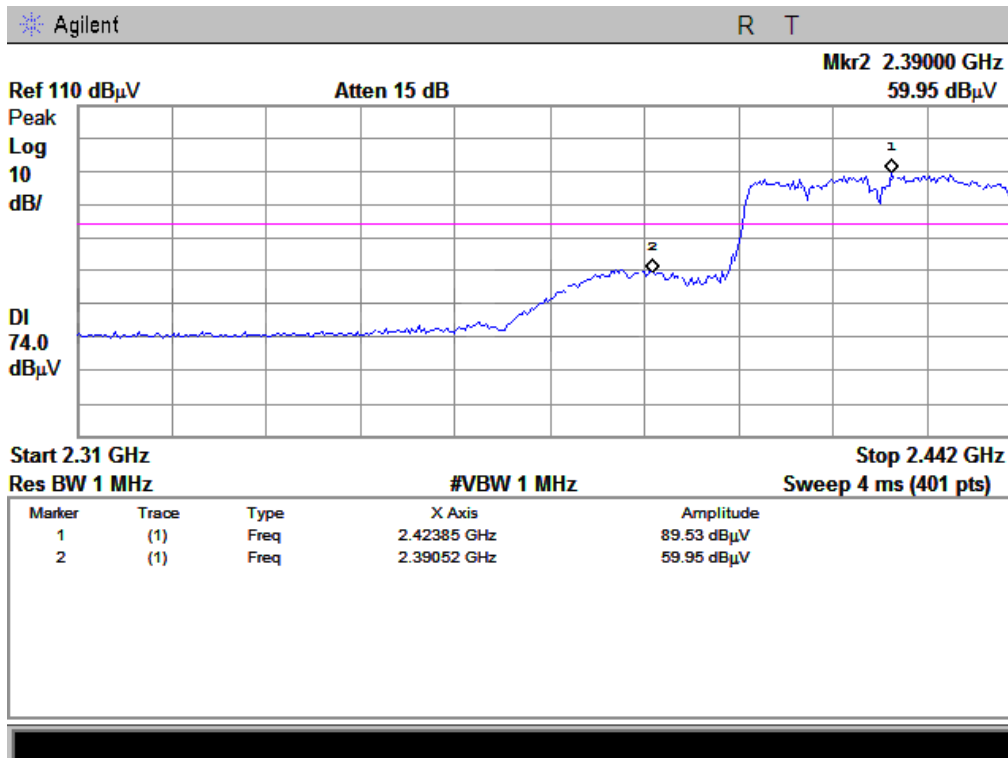

(CH Low, Peak)

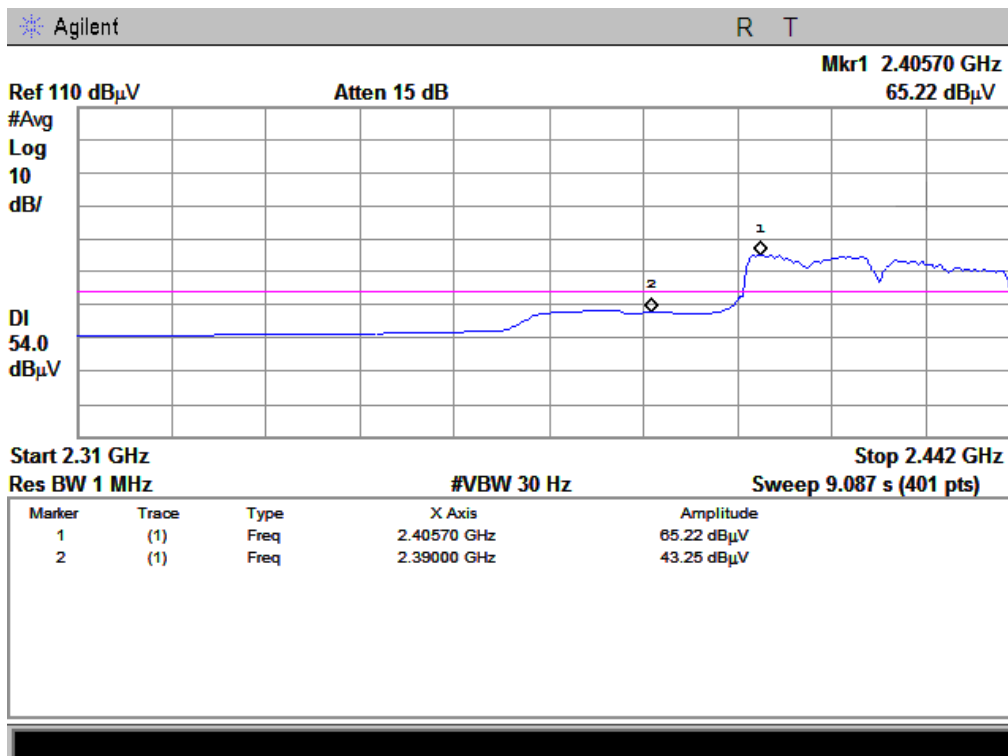

(CH Low, Average)

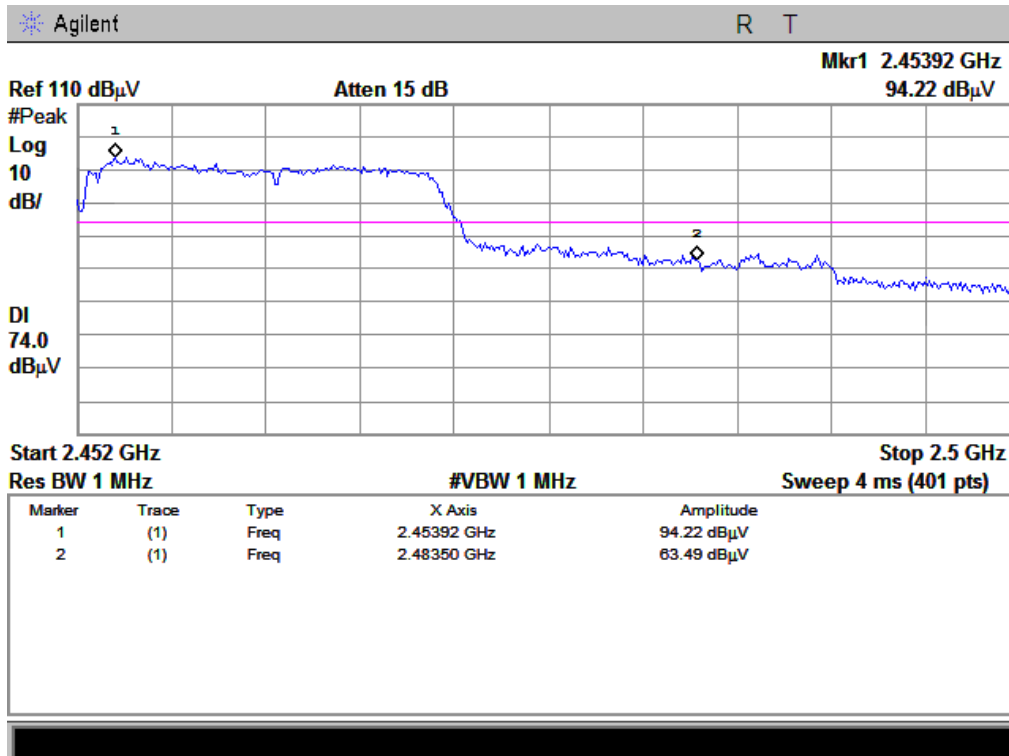

(CH High, Peak)

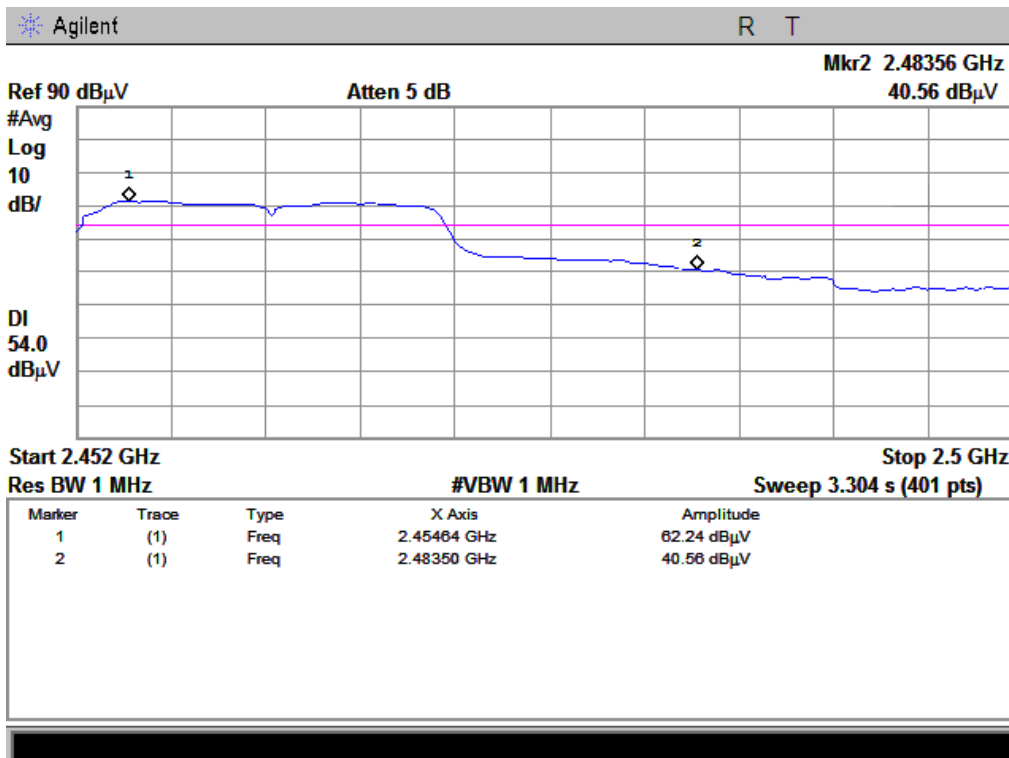

(CH High, Average)

APPENDIX 1
PHOTOGRAPHS OF TEST SETUP

CE TEST SETUP



RE TEST SETUP



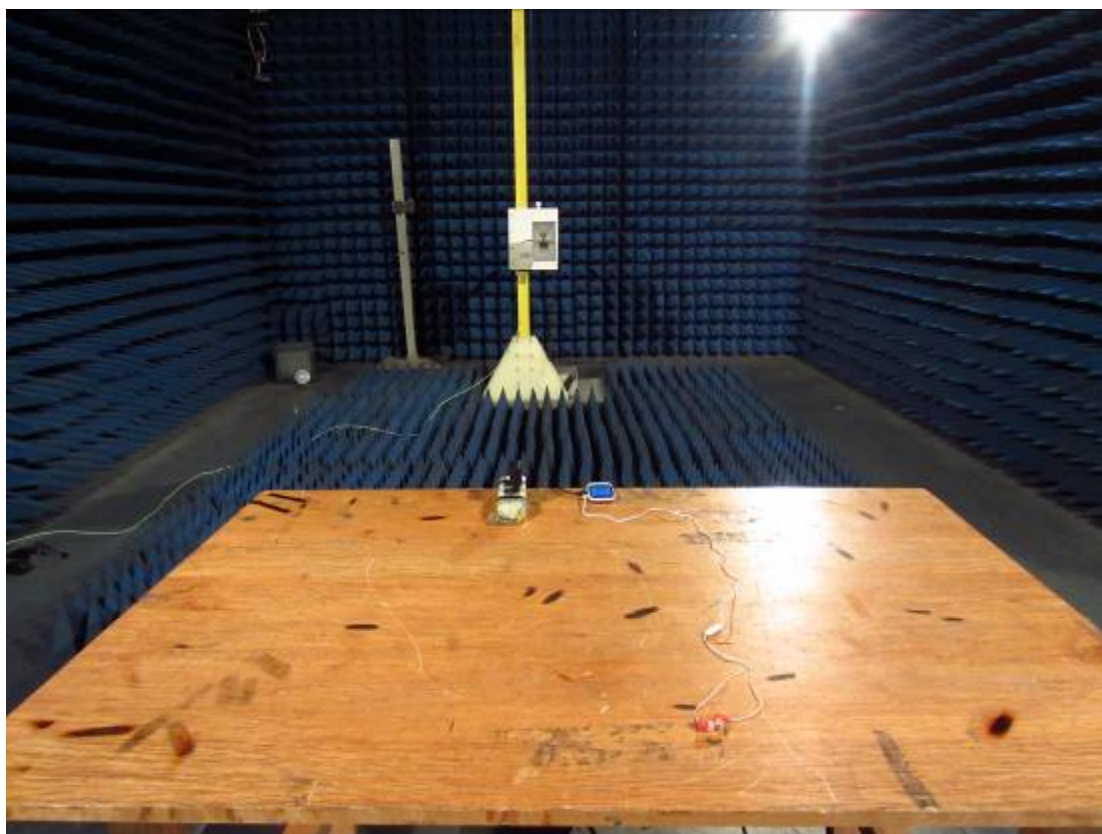

CONDUCTED TEST SETUP

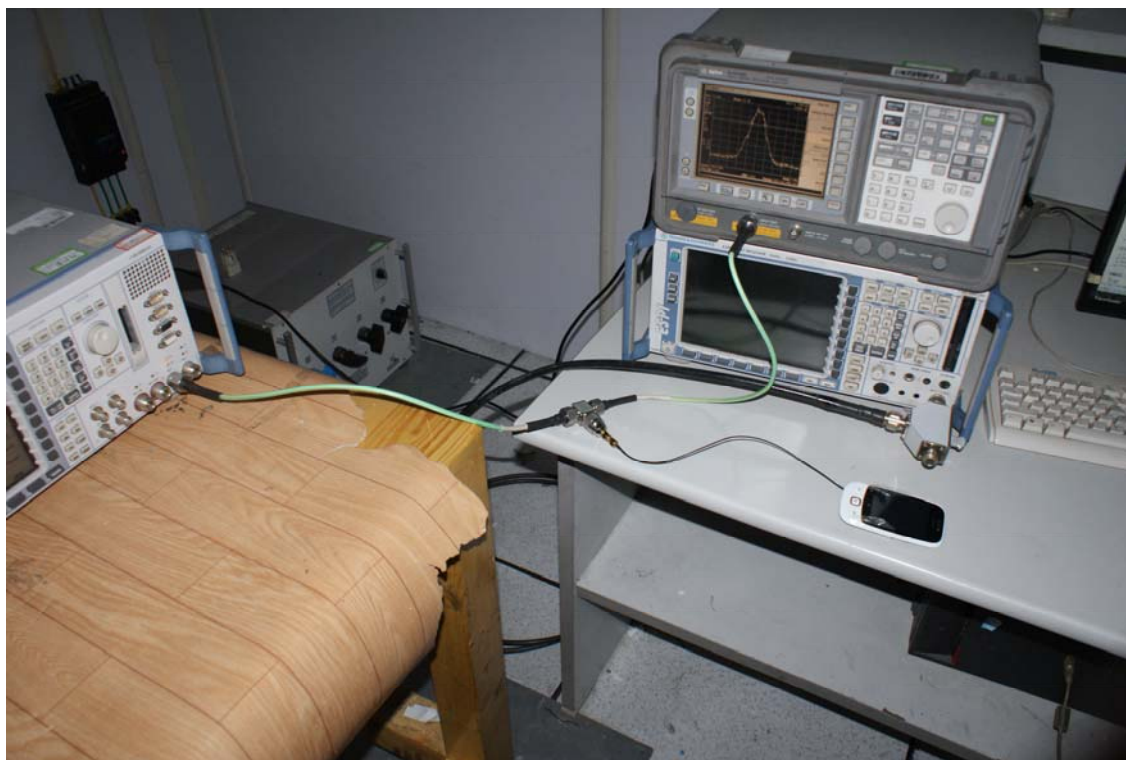

APPENDIX 2
PHOTOGRAPHS OF EUT

FRONT VIEW OF SAMPLE



BACK VIEW OF SAMPLE



LEFT VIEW OF SAMPLE



RIGHT VIEW OF SAMPLE



UP VIEW OF SAMPLE



DOWN VIEW OF SAMPLE



PHOTO OF CHARGER



PHOTO OF HEADPHONE



PHOTO OF BATTERY



PHOTO OF USB CABLE



INTERNAL PHOTO OF SAMPLE - 1



INTERNAL PHOTO OF SAMPLE -2



INTERNAL PHOTO OF SAMPLE - 3



INTERNAL PHOTO OF SAMPLE - 4

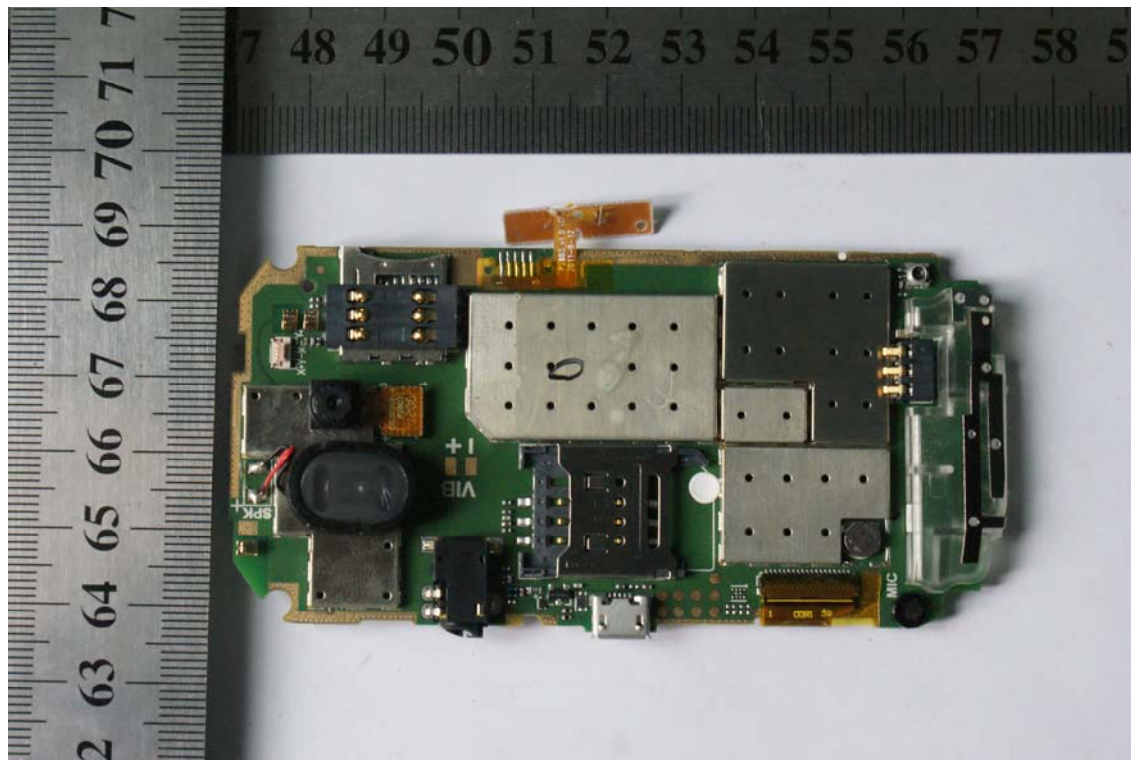

INTERNAL PHOTO OF SAMPLE - 5

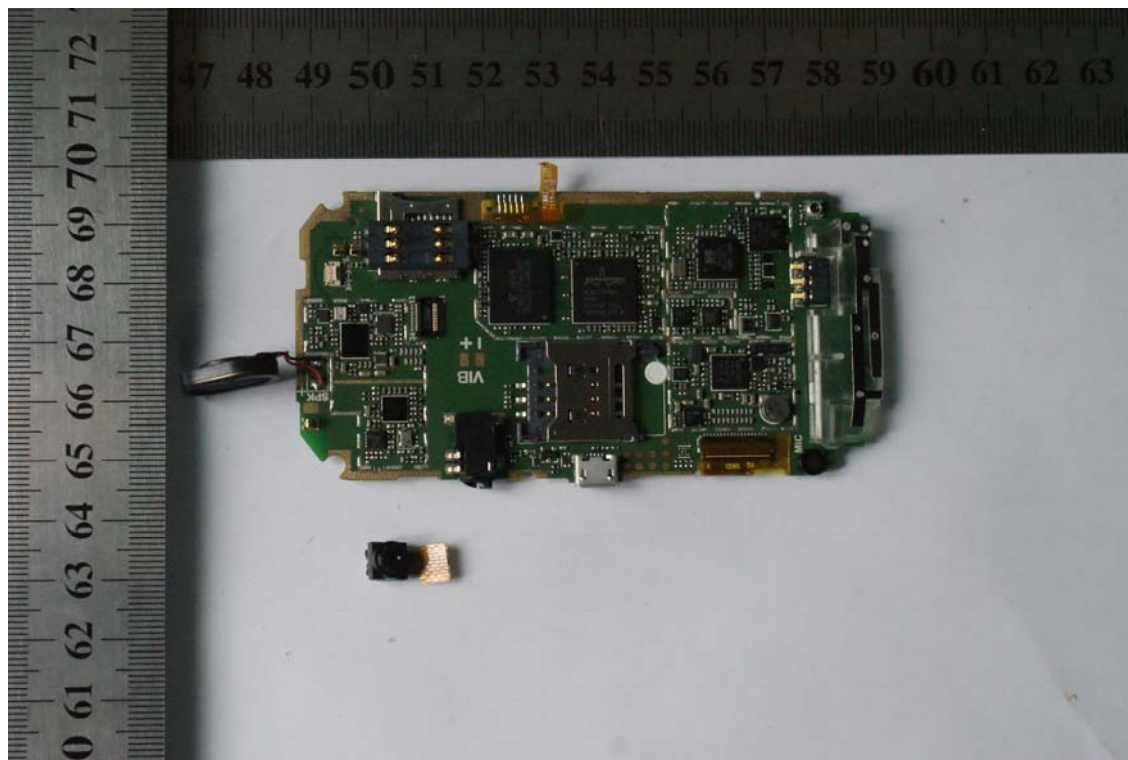

INTERNAL PHOTO OF OTHER SAMPLE





-----END OF REPORT-----