

UOCTSN is used as U1RXD  
UORTSN is used as U1TXD and NBOOT

Freecom		
Project#°	<project>	Design by#° <Design>
Title#°	<title>	Check by#° <check>
REV#°	<REV>	Approve#° <appr>
File NO.#°	<file no>	sheet: 1 / 13

CAUTION: I2C has been pulled up by SC6600L, don't pull up it again

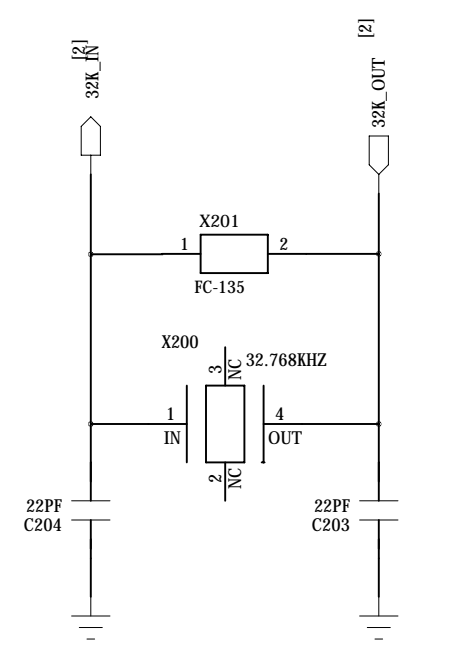
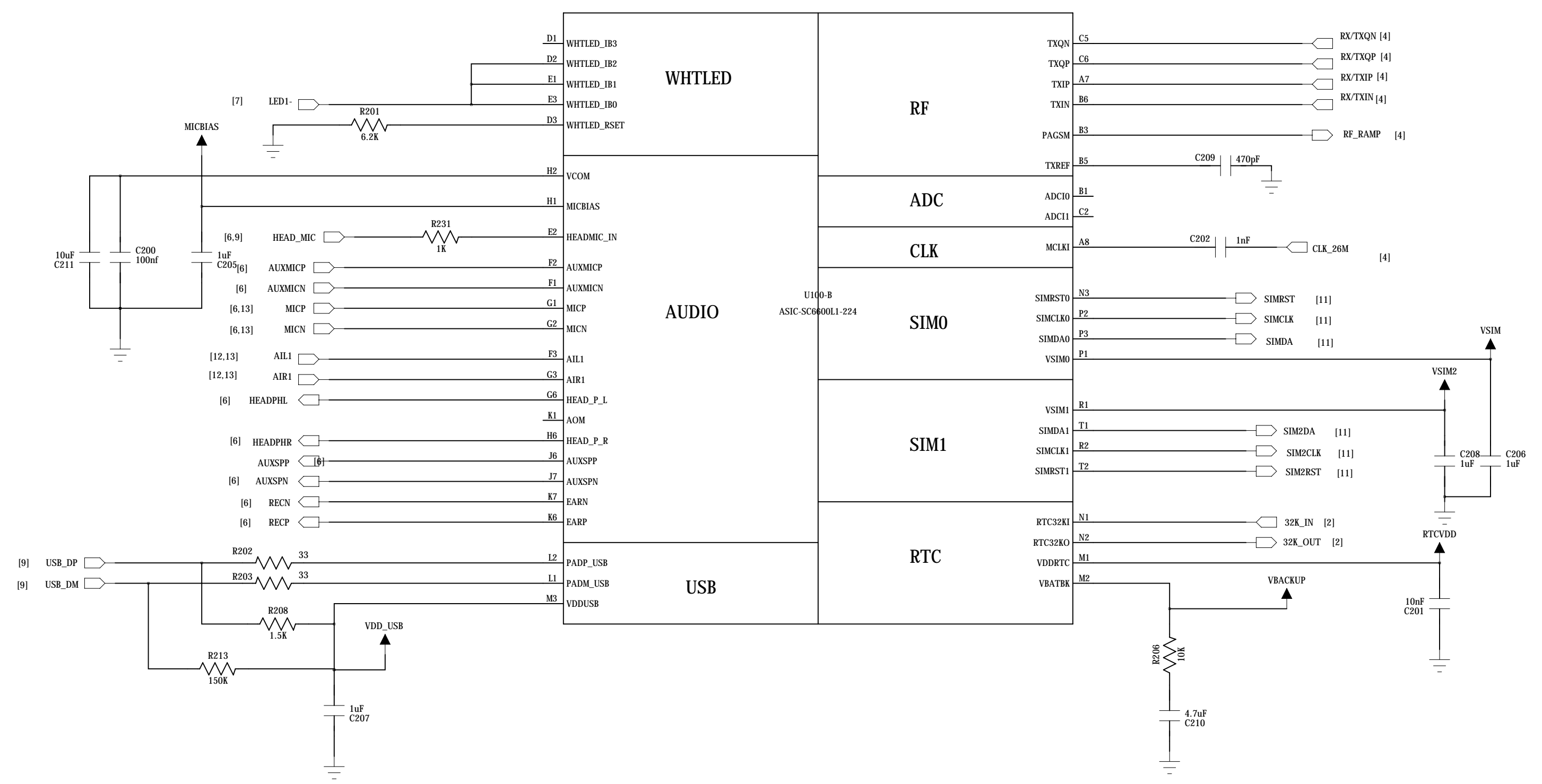

Freecom		
Project#°	<project>	Design by#° <Design>
Title#°	<title>	Check by#° <check>
REV#°	<REV>	Approve#° <appr>
File NO.#°	<file no>	sheet: 2 / 13



REVISION RECORD			
LTR	ECO NO.	APPROVED	DATE

**Dual band NF part**  
 U401 £ - U403 £ - C432 £ - C433 £ - C424 £ - C451  
 C416 £ - C417 £ - C412 £ - C454, L402, L407

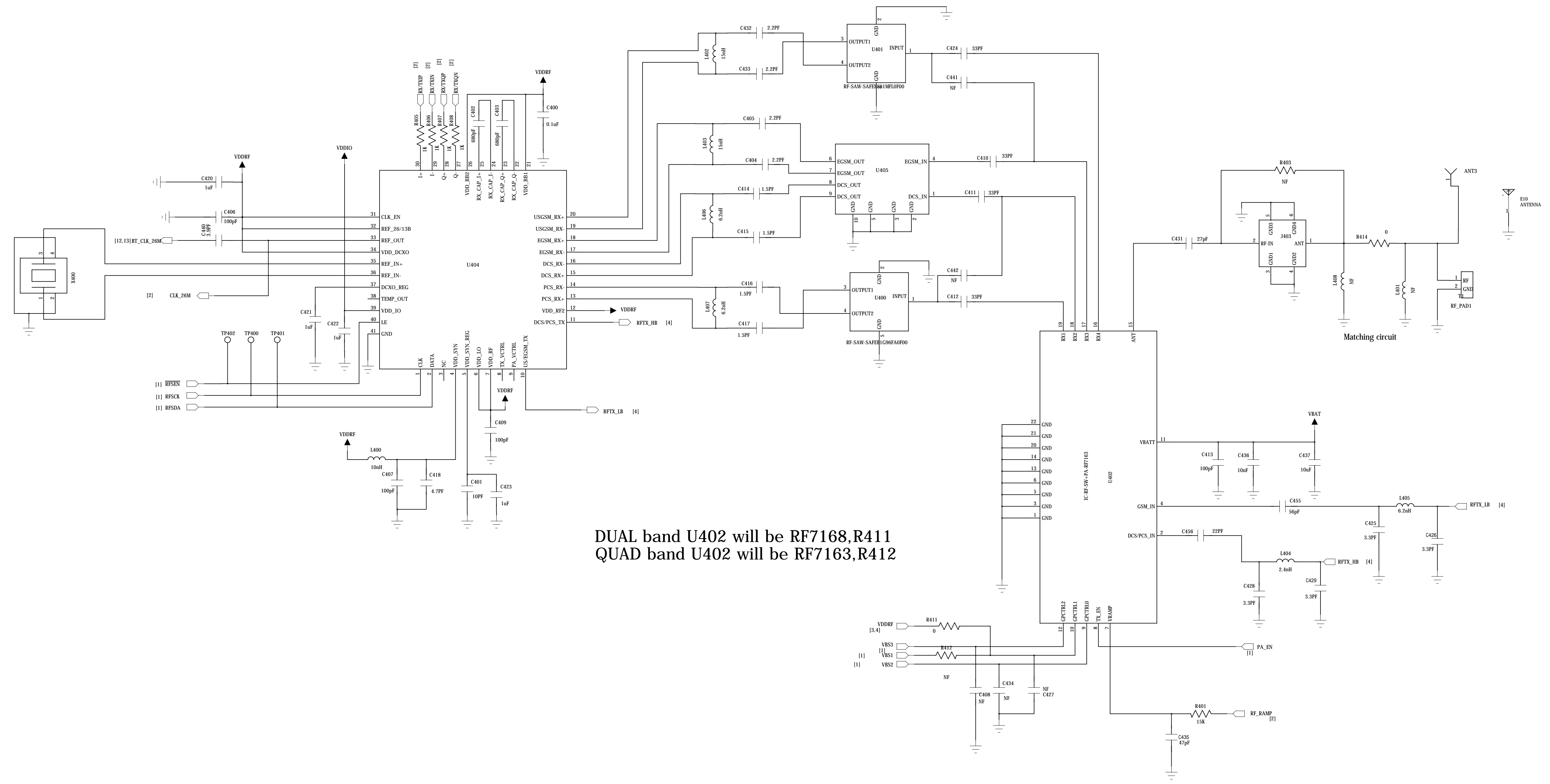

DUAL band U402 will be RF7168, R411  
 QUAD band U402 will be RF7163, R412

TITLE & REV:		
DOCUMENT NO.:		
DESIGNER:	DATED:	DEPARTMENT:
EQ:	DATED:	COMPANY:
APPROVED:	DATED:	
CONFIDENTIAL AND PROPRIETARY		SHEET: 4 OF 17

# NOR+pSRAM

when stl3610t7050 R521 0R,R522 NC  
else R521 NC,R522 0R

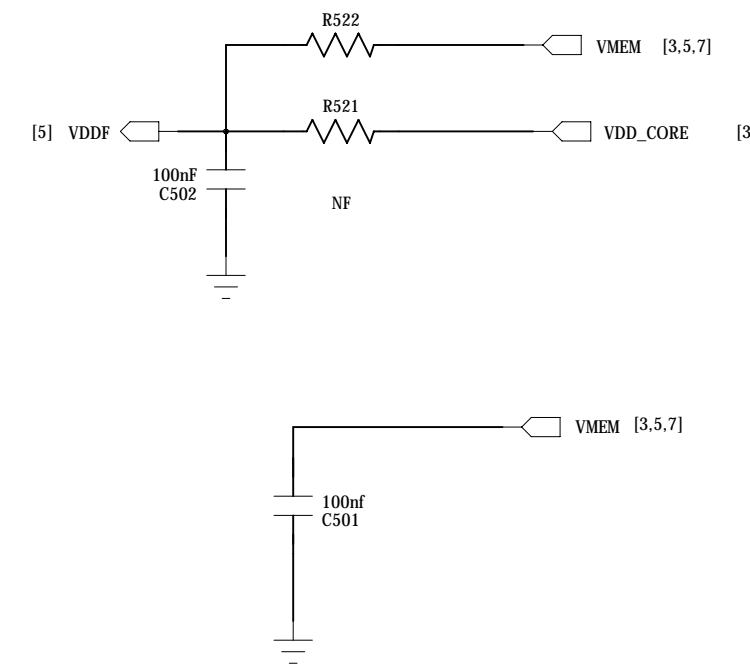

## Strapping List

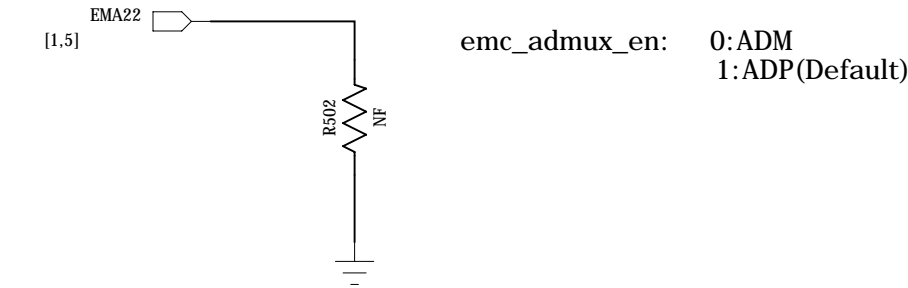

emc\_admux\_en: 0:ADM  
1:ADP(Default)

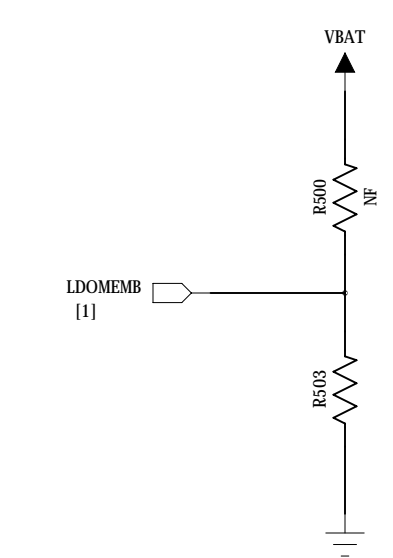

LDOMEMB: 0:VDDMEM 3V  
1:VDDMEM 1.8V

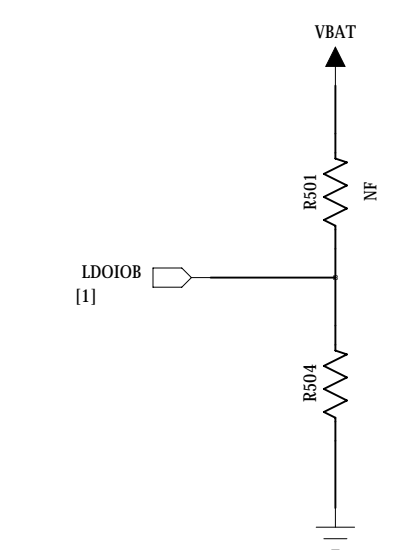

LDOIOB: 0:VDDIO 2.8V  
1:VDDIO 1.8V

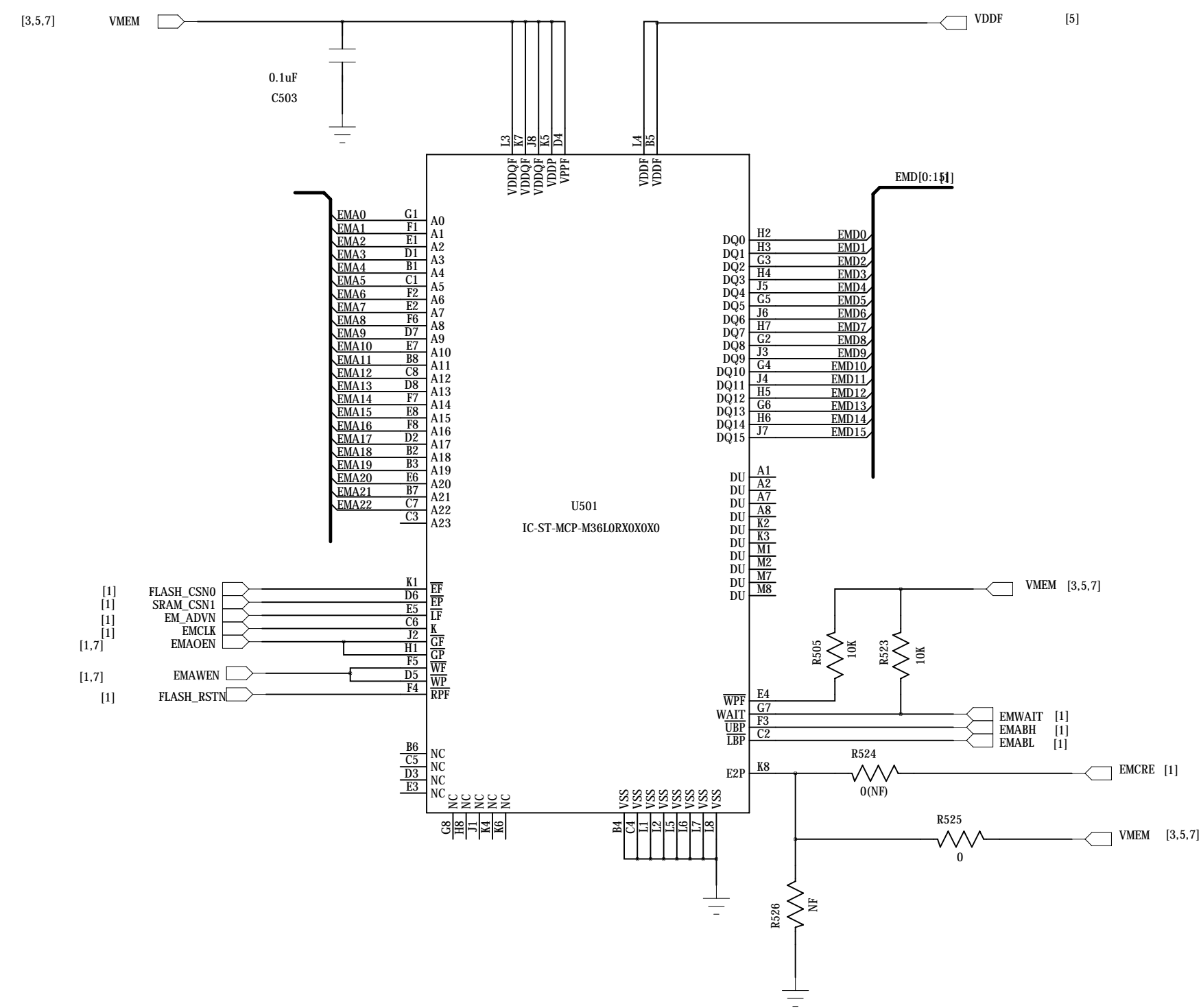

CAUTION: MCP signals have higher speed than before, layout carefully

Freecom	
Project#°	<project>
Design by#°	<Design>
Title#°	<title>
Check by#°	<check>
REV#°	<REV>
Approve#°	<appr>
File NO.#°	<file no>
sheet:	5 / 13

## MAIN MIC

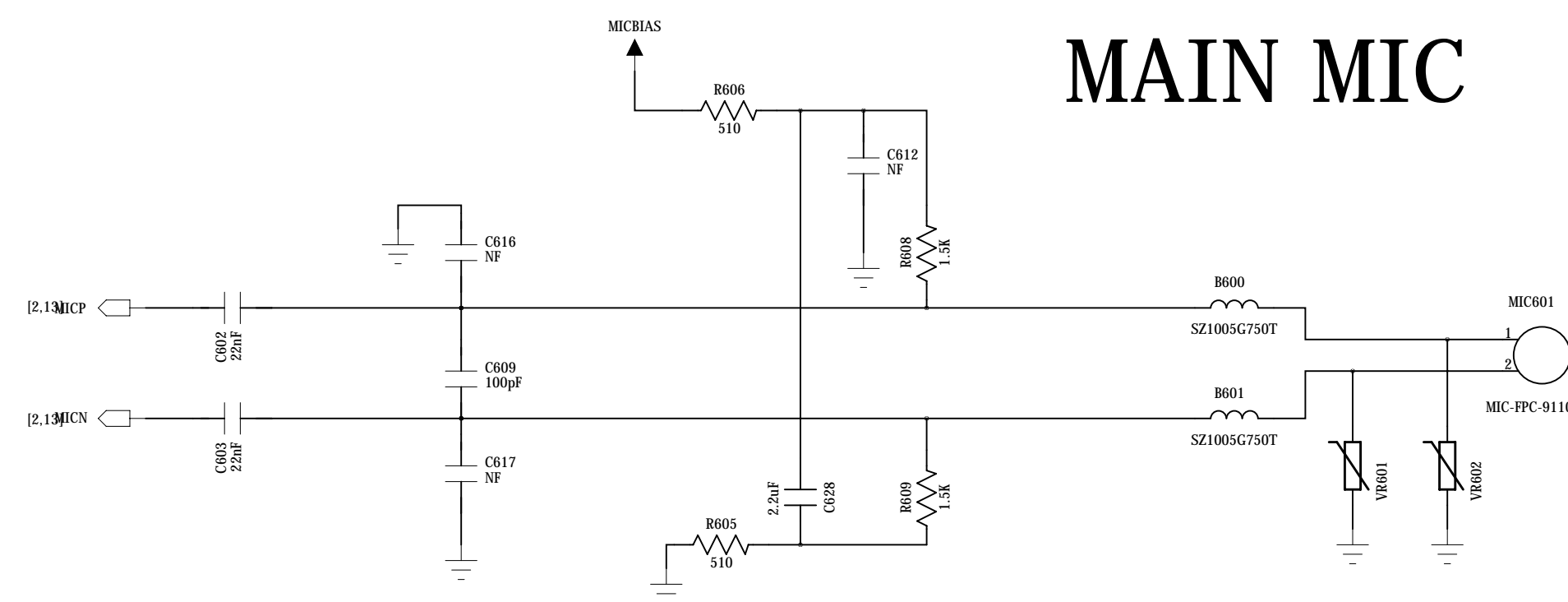

## EAR-MIC

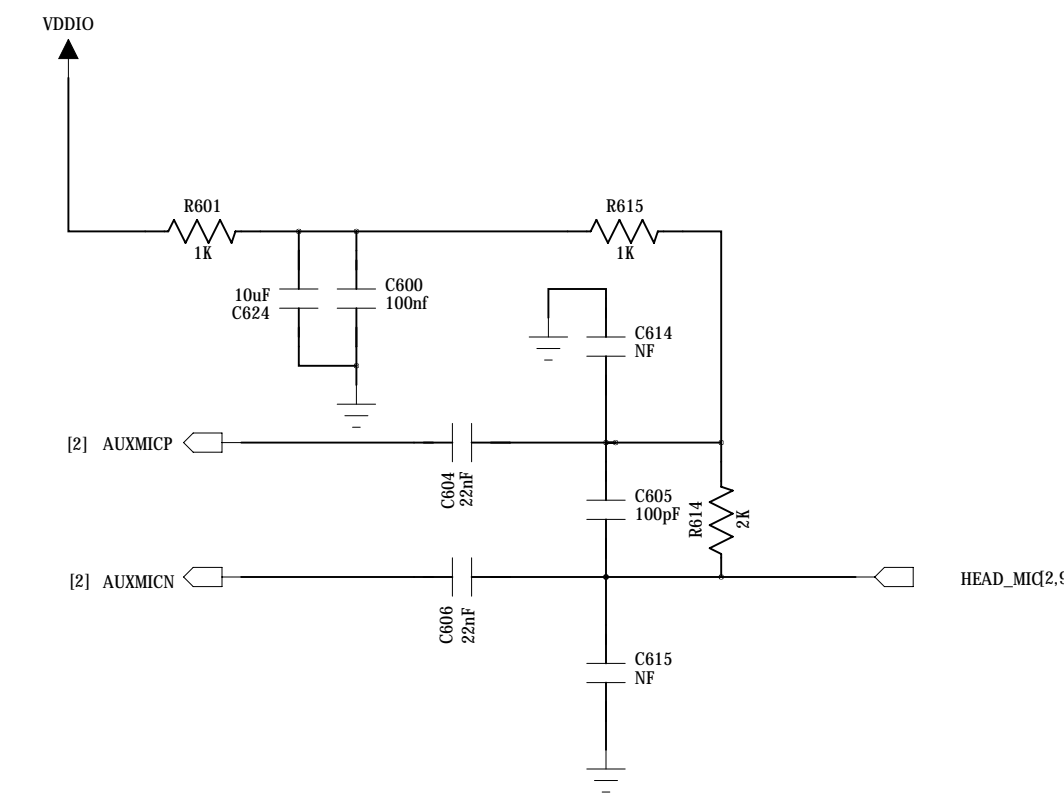

## RECEIVER

### Class AB

If use combined speaker and receiver ,then Analog switch are needed to prevent reverse current. Pls refer to <<SC6600H Speaker&Receiver Application Notes>>

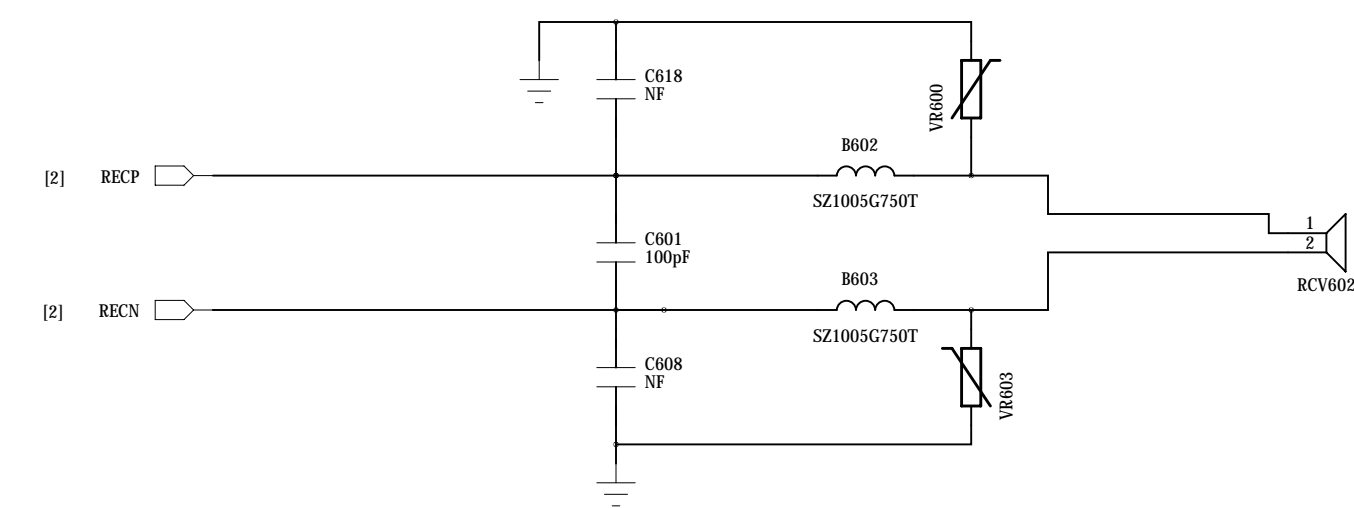

## HEADPHONE

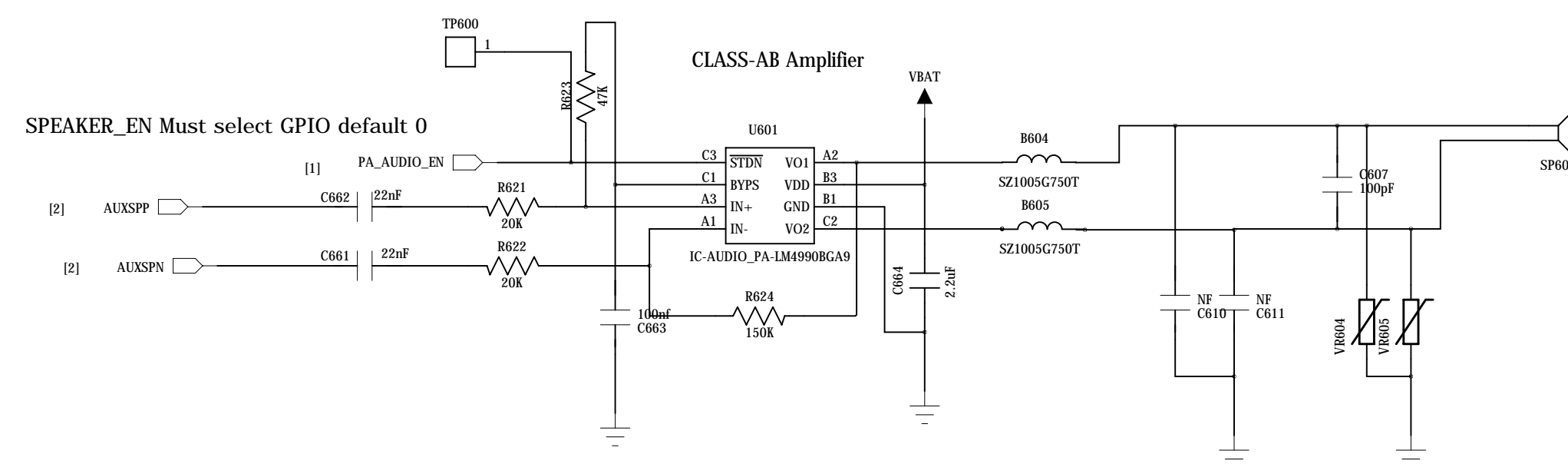
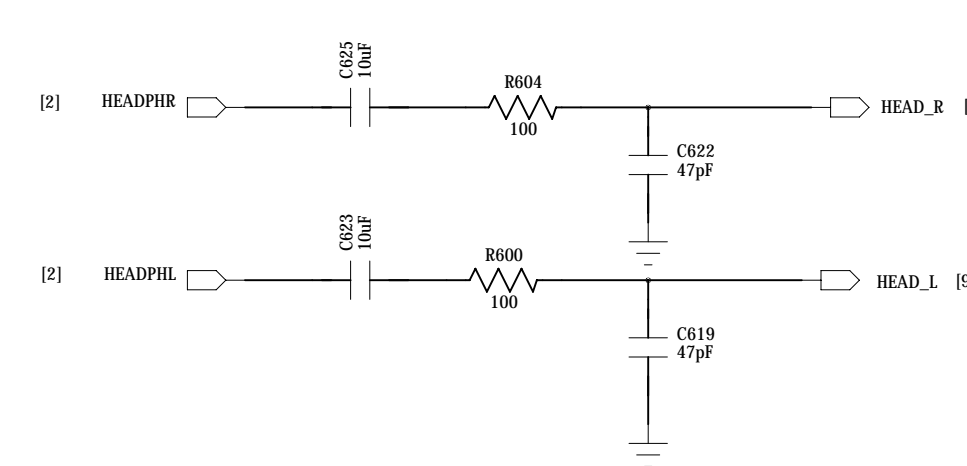

## Freecom

Project#°	<project>	Design by#°	<Design>
Title#°	<title>	Check by#°	<check>
REV#°	<REV>	Approve#°	<appr>
File NO.#°	<file no>	sheet:	6 / 13

# LCM\_2.0

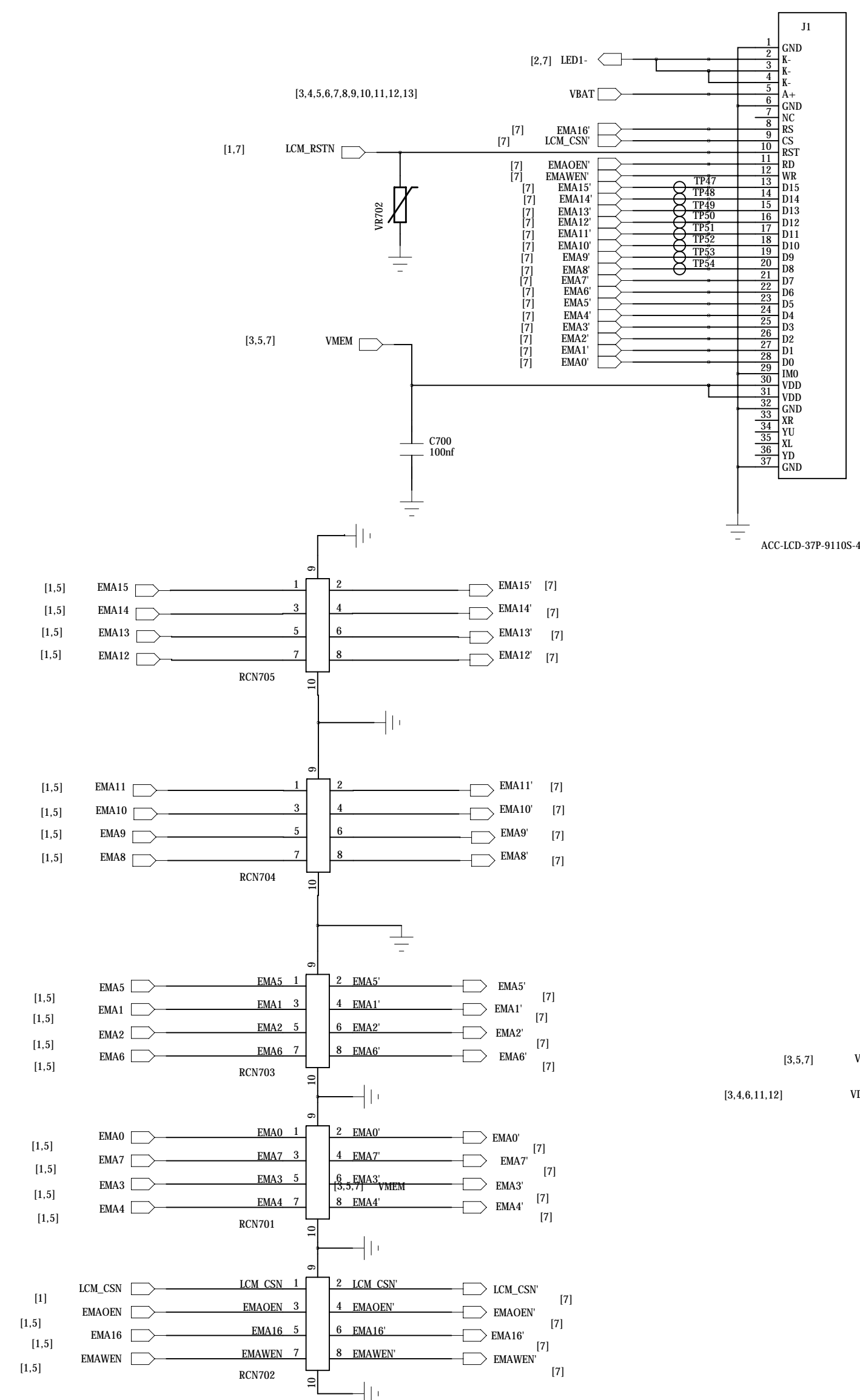

# LCM\_1.77TFT\_DATA8

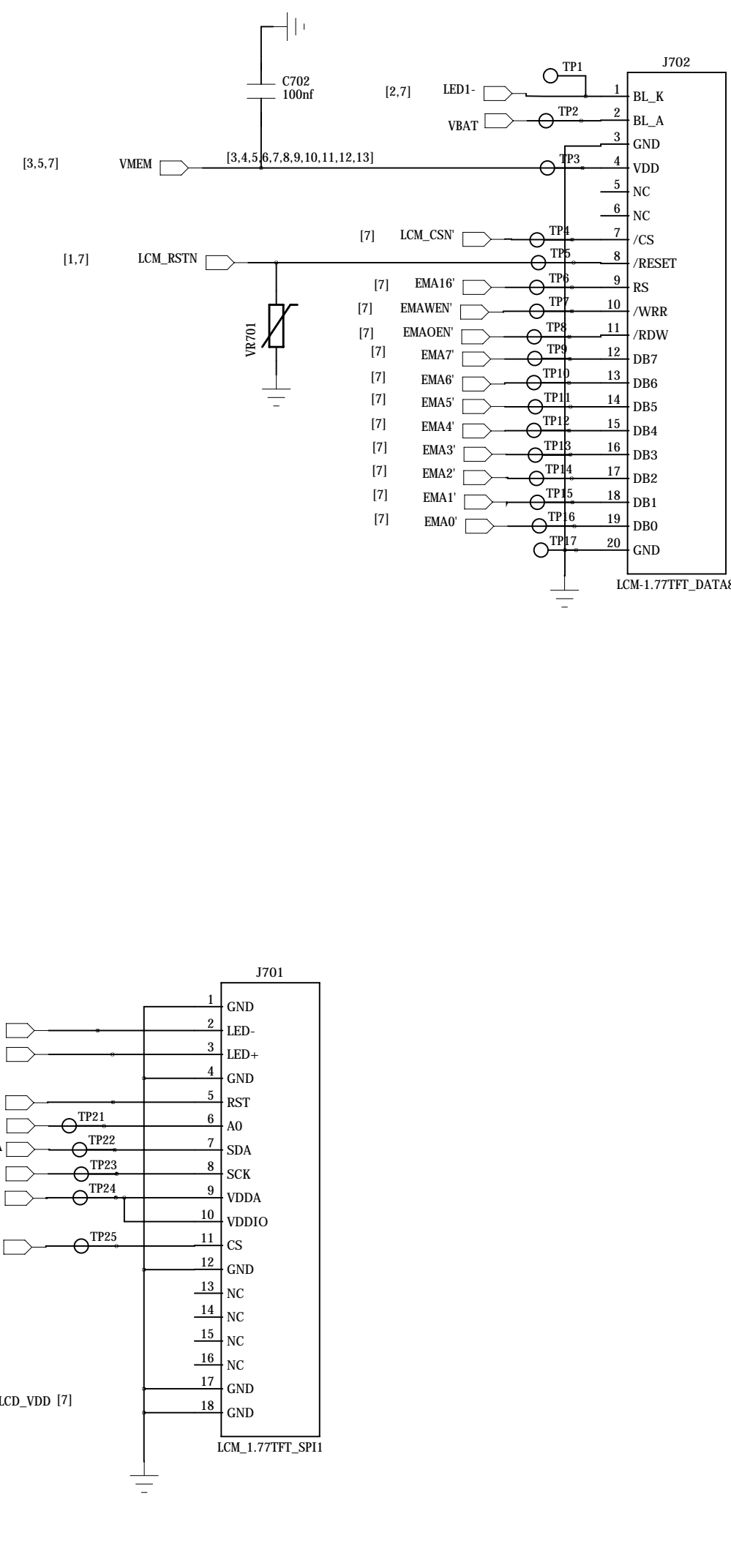

Freecom	
Project#°	<project>
Title#°	<title>
REV#°	<REV>
File NO.£°	<file no>
Design by#°	<Design>
Check by#°	<check>
Approve#°	<appr>
sheet:	7 / 13

# CAMERA1

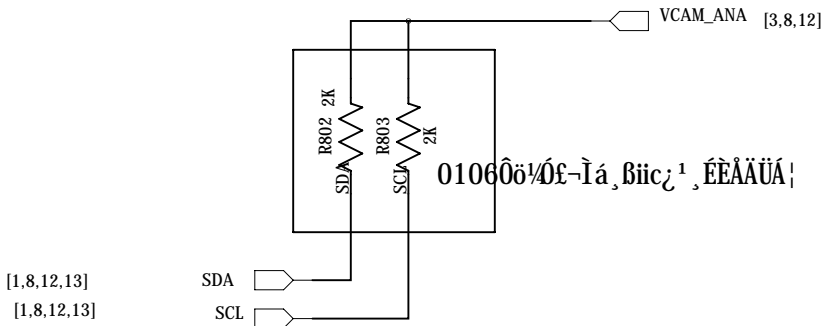
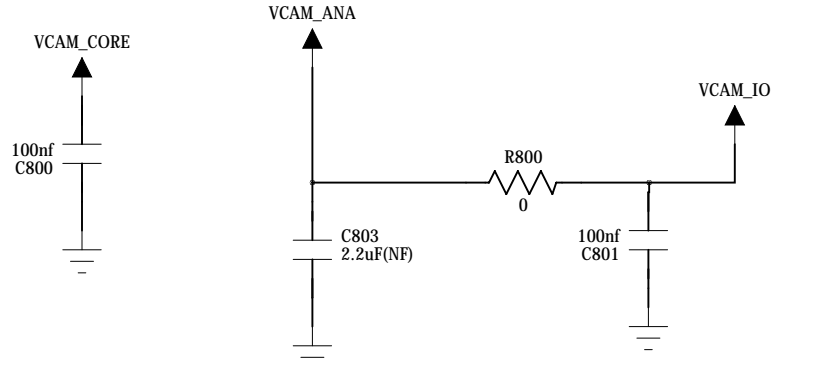
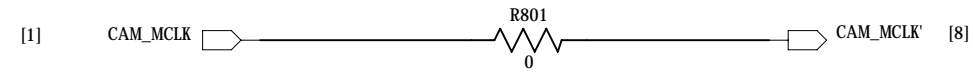

## 7202\_21PIN\_CAM

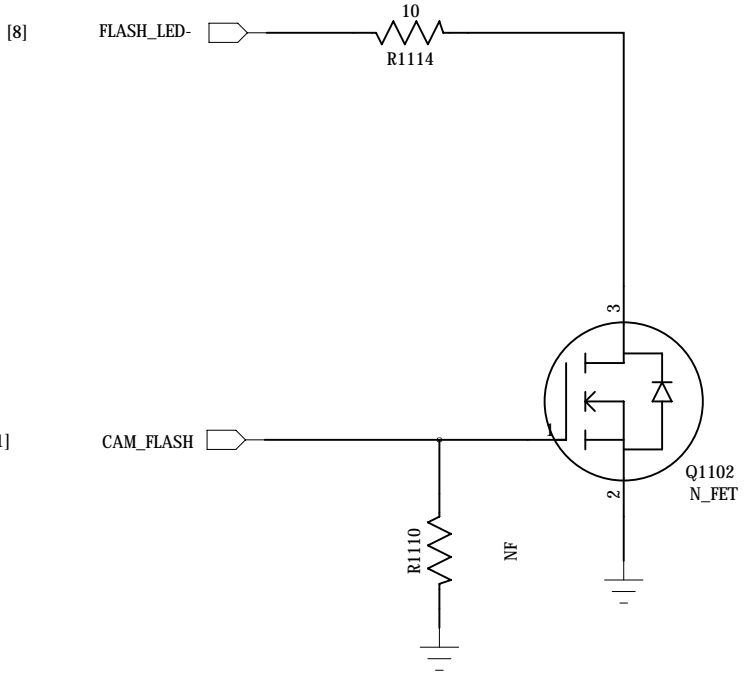
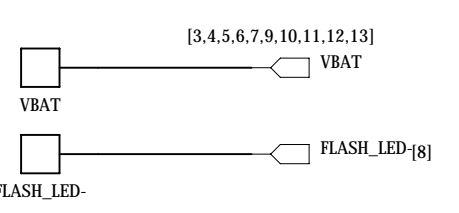
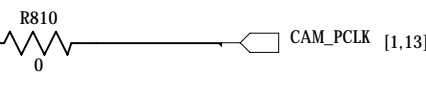
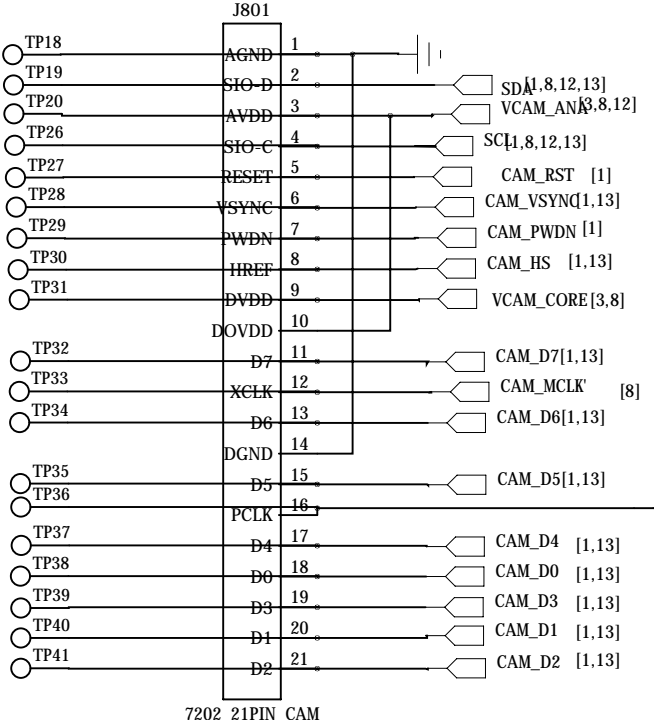

Freecom		
Project°	<project>	Design by° <Design>
Title°	<title>	Check by° <check>
REV°	<REV>	Approve° <appr>
File NO.°	<file no>	sheet: 8 / 13



# INTERFACE

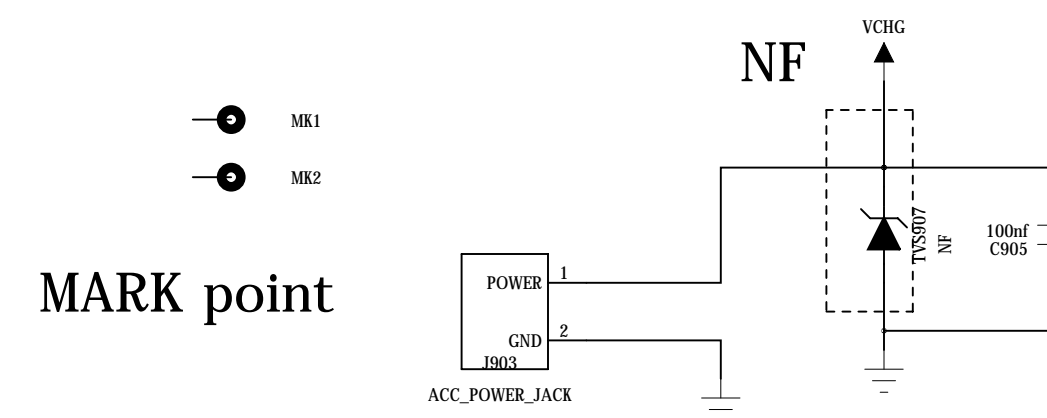
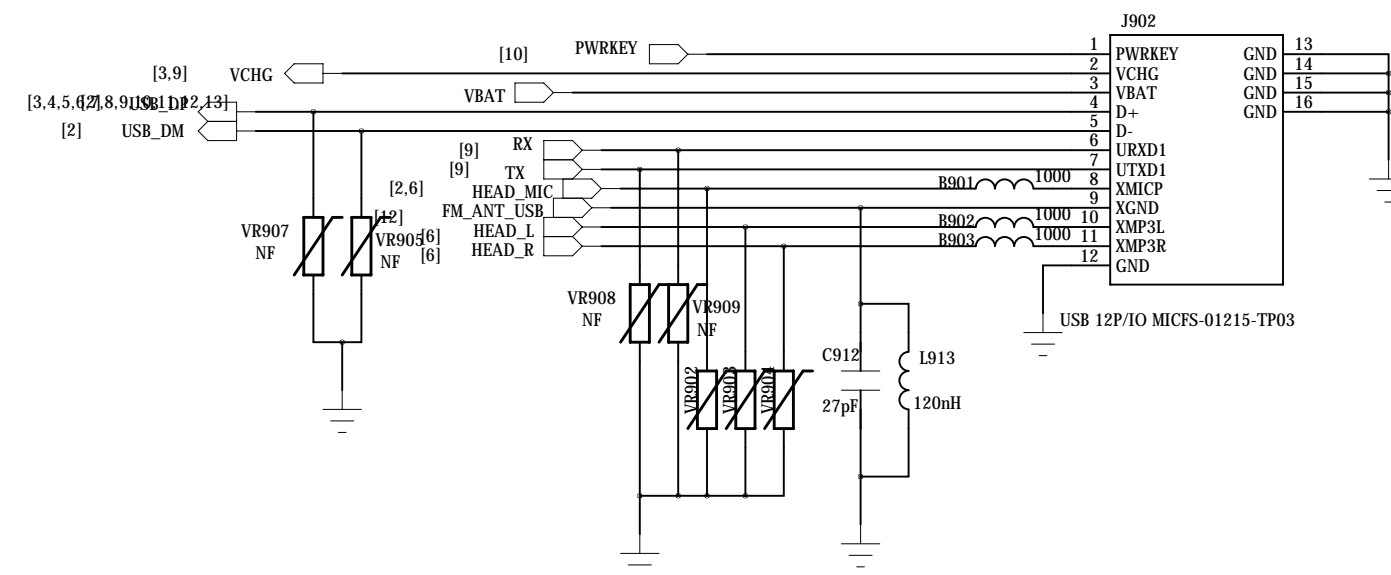

Boot select:  
 UORSTN = low --> boot from USB  
 UORSTN = high --> boot from NOR or UART  
 NOTE: keyin0 & keyout0 pressed when power up will also lead to USB boot

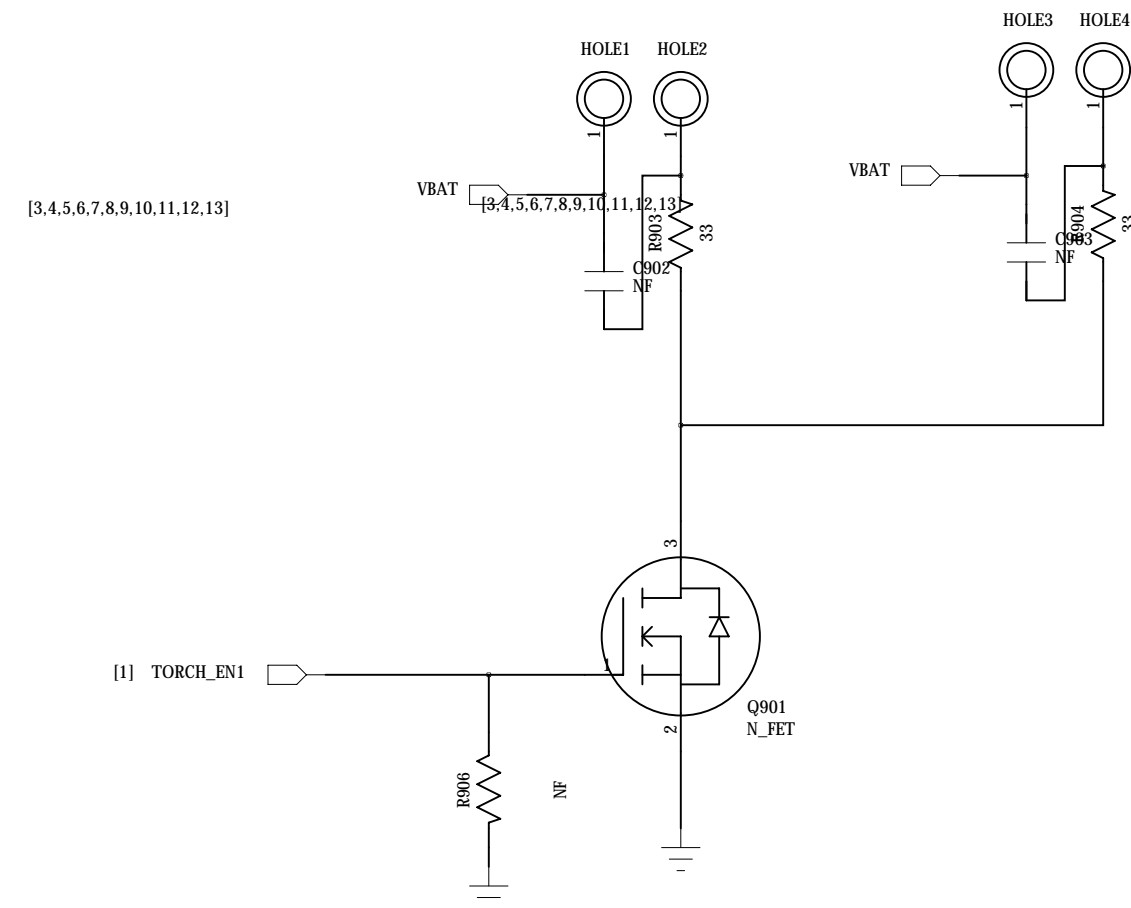

Freecom		
Project#	<project>	Design by# <Design>
Title#	<title>	Check by# <check>
REV#	<REV>	Approve# <appr>
File NO.#	<file no>	sheet: 9 / 13

Press this button when power up will make the phone boot from USB

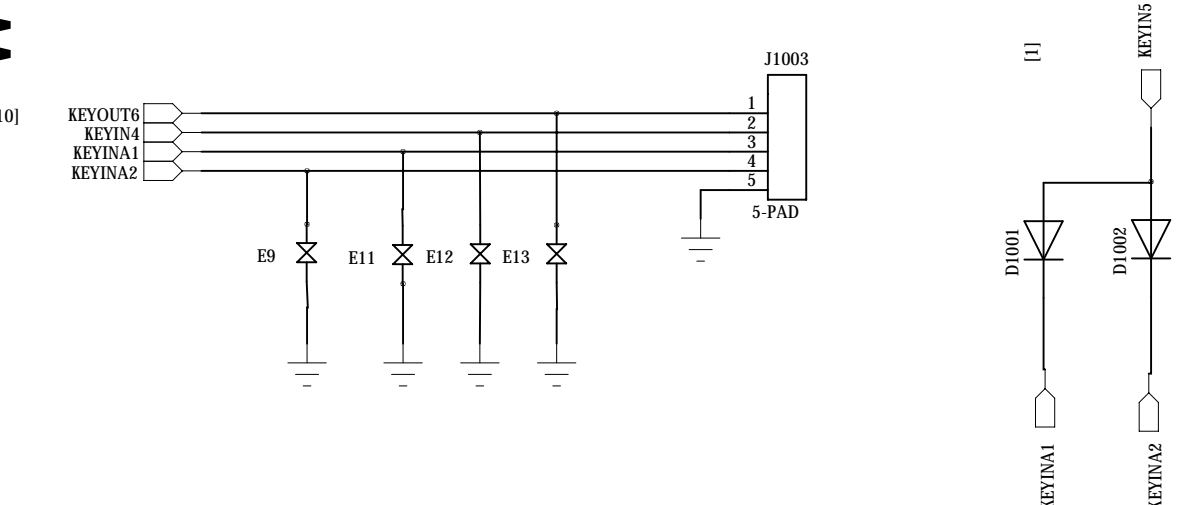
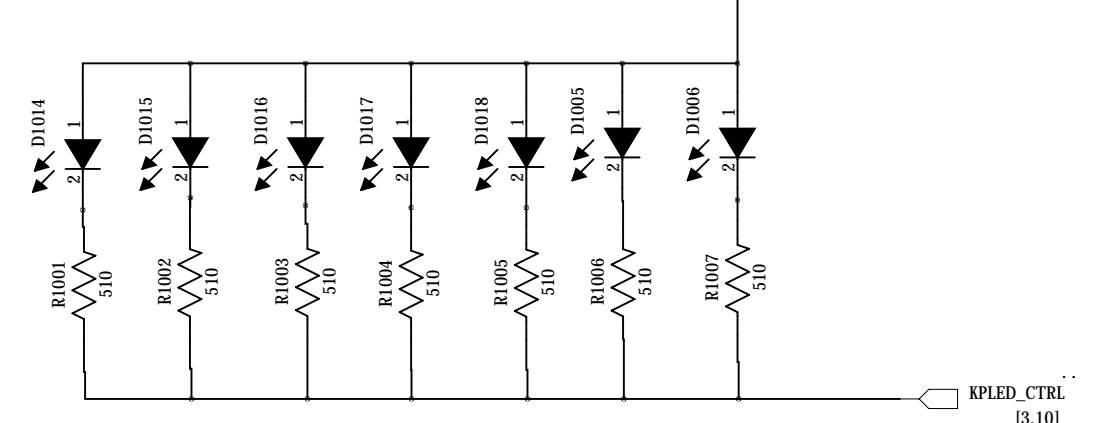
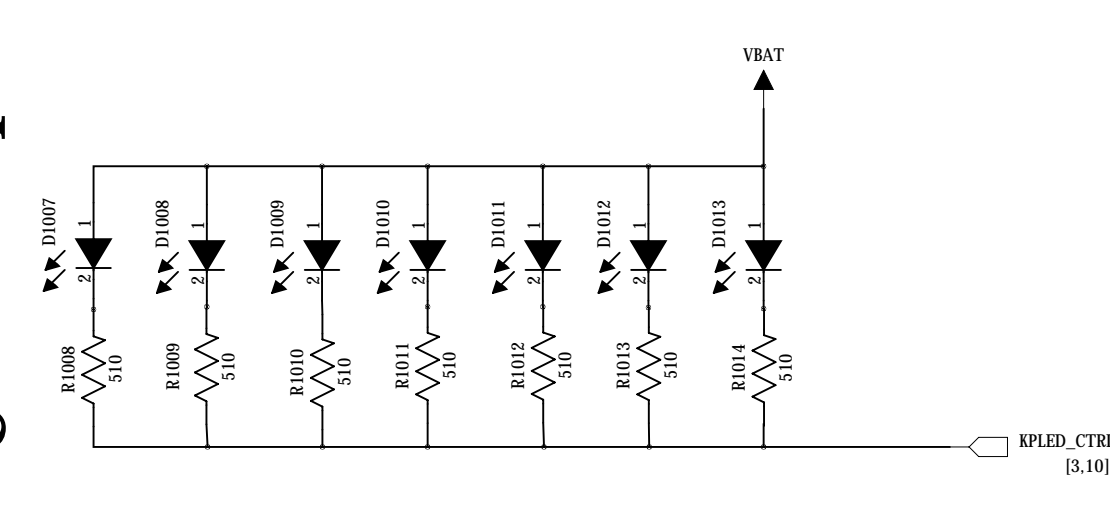
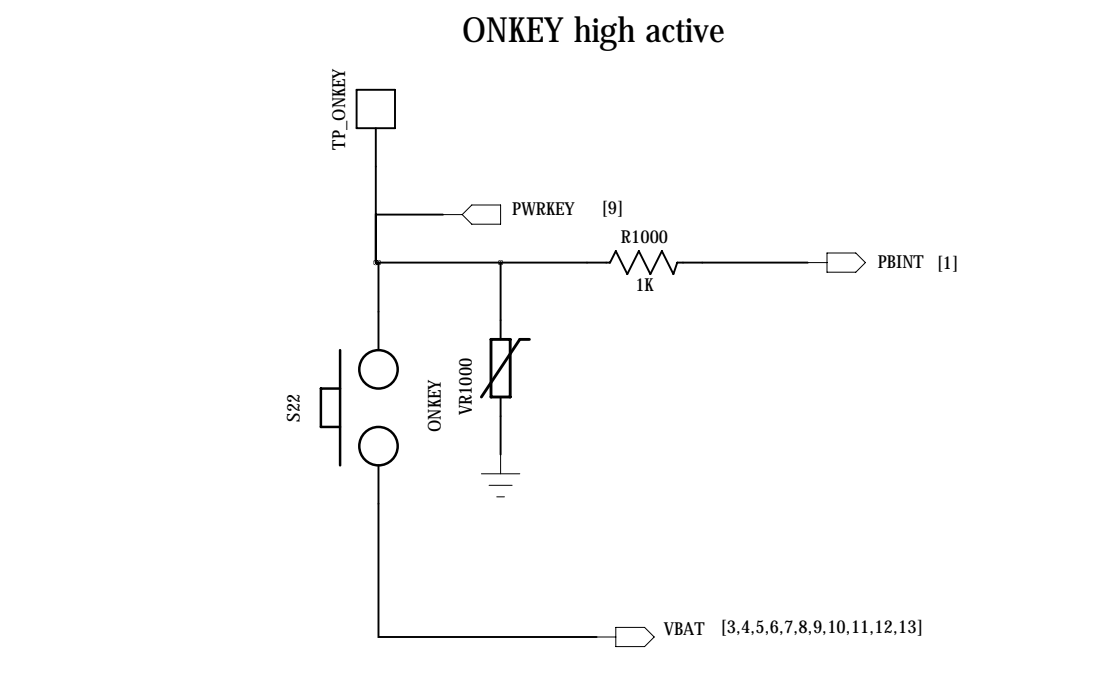
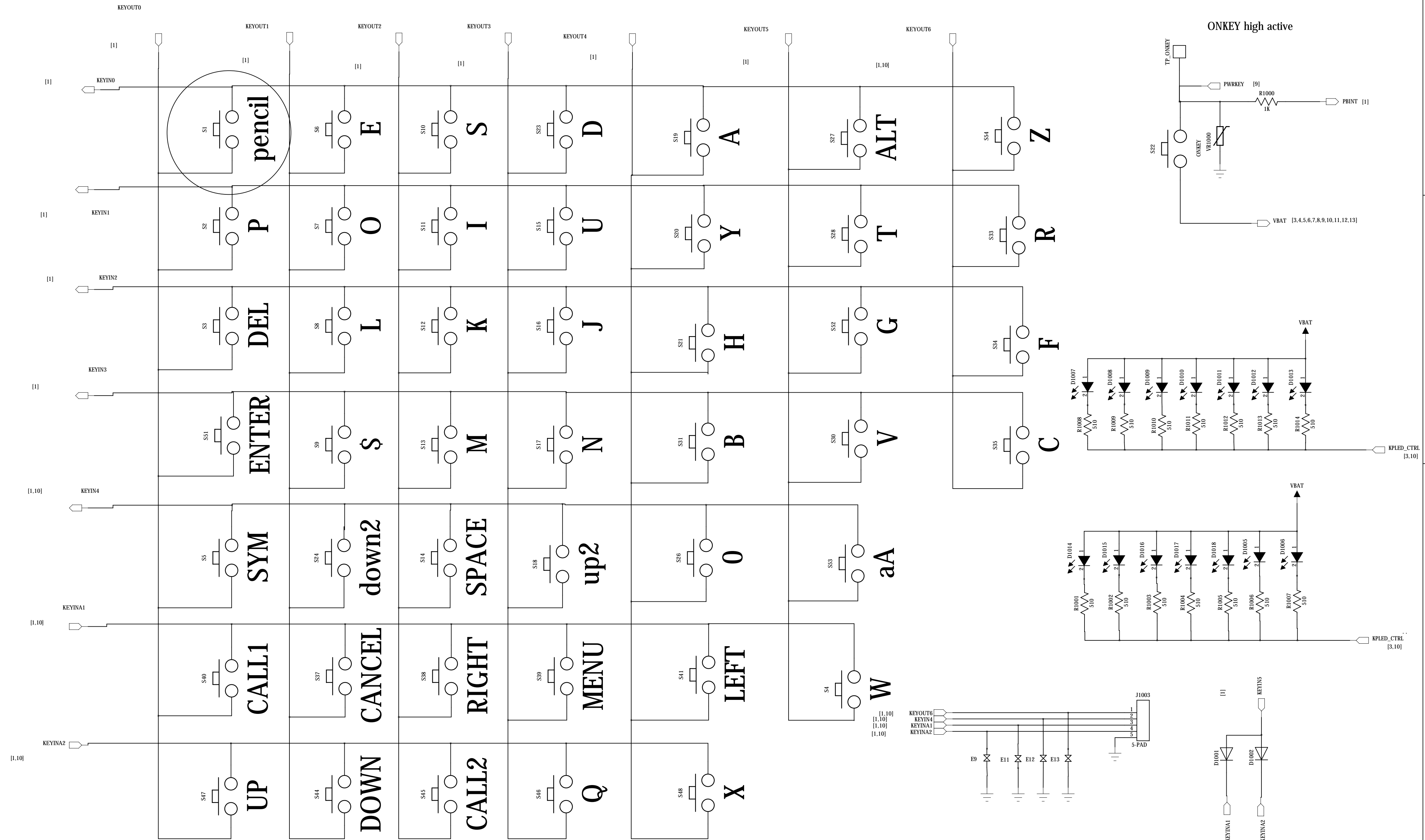

**Freecom**

Project#°	<project>	Design by#°	<Design>
Title#°	<title>	Check by#°	<check>
REV#°	<REV>	Approve#°	<appr>
File NO.#°	<file no>	sheet:	10/ 13

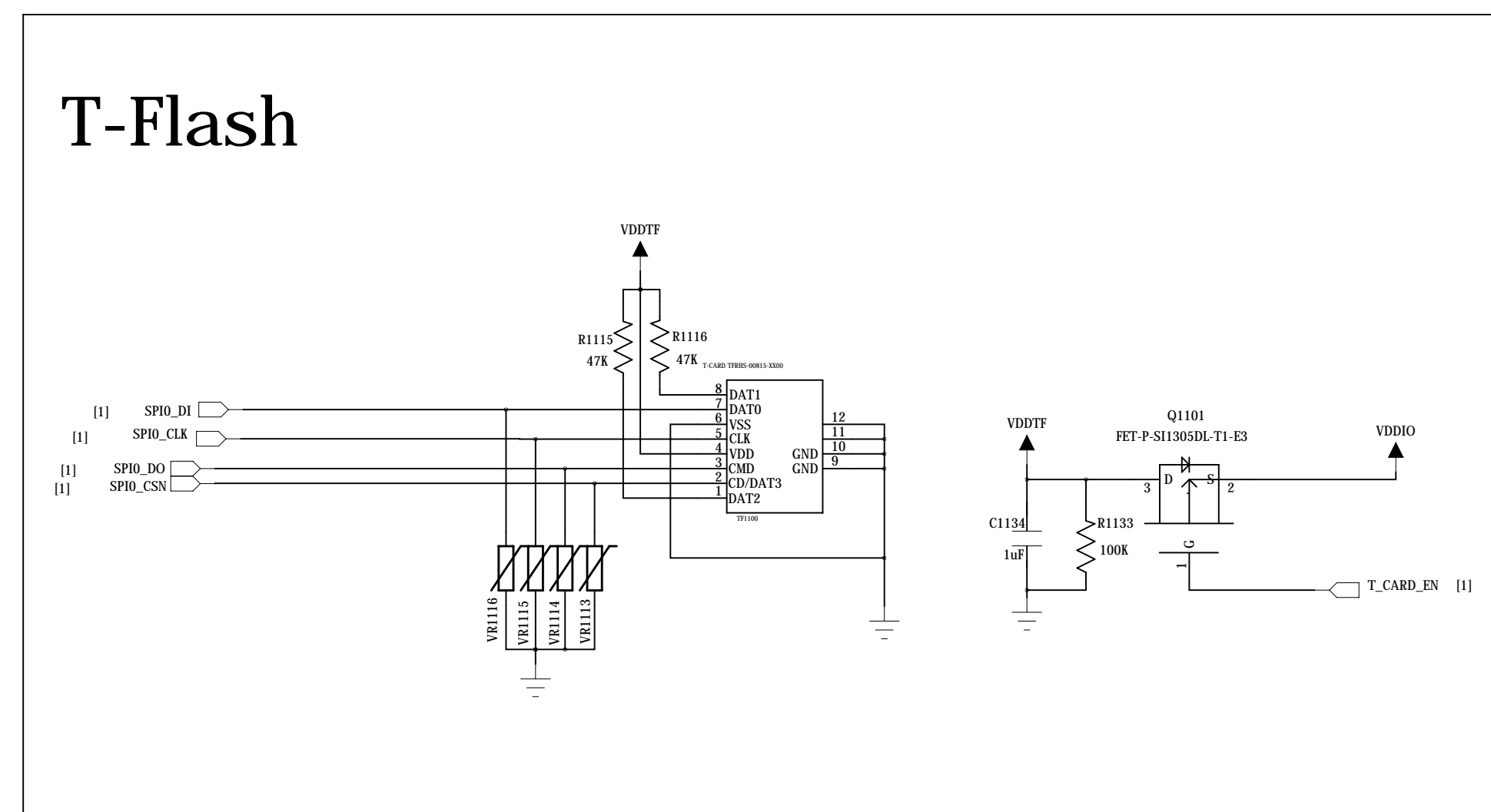
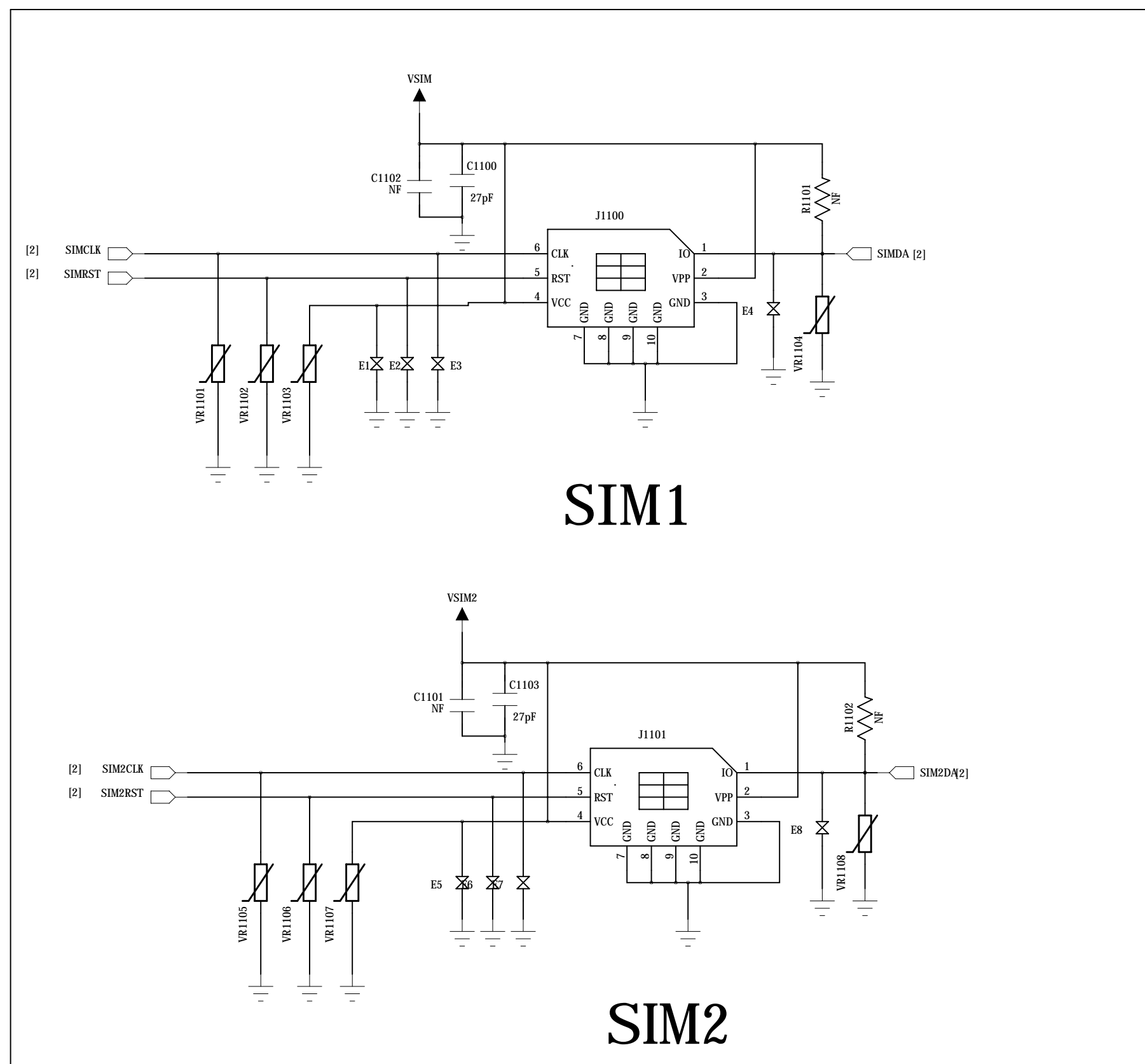
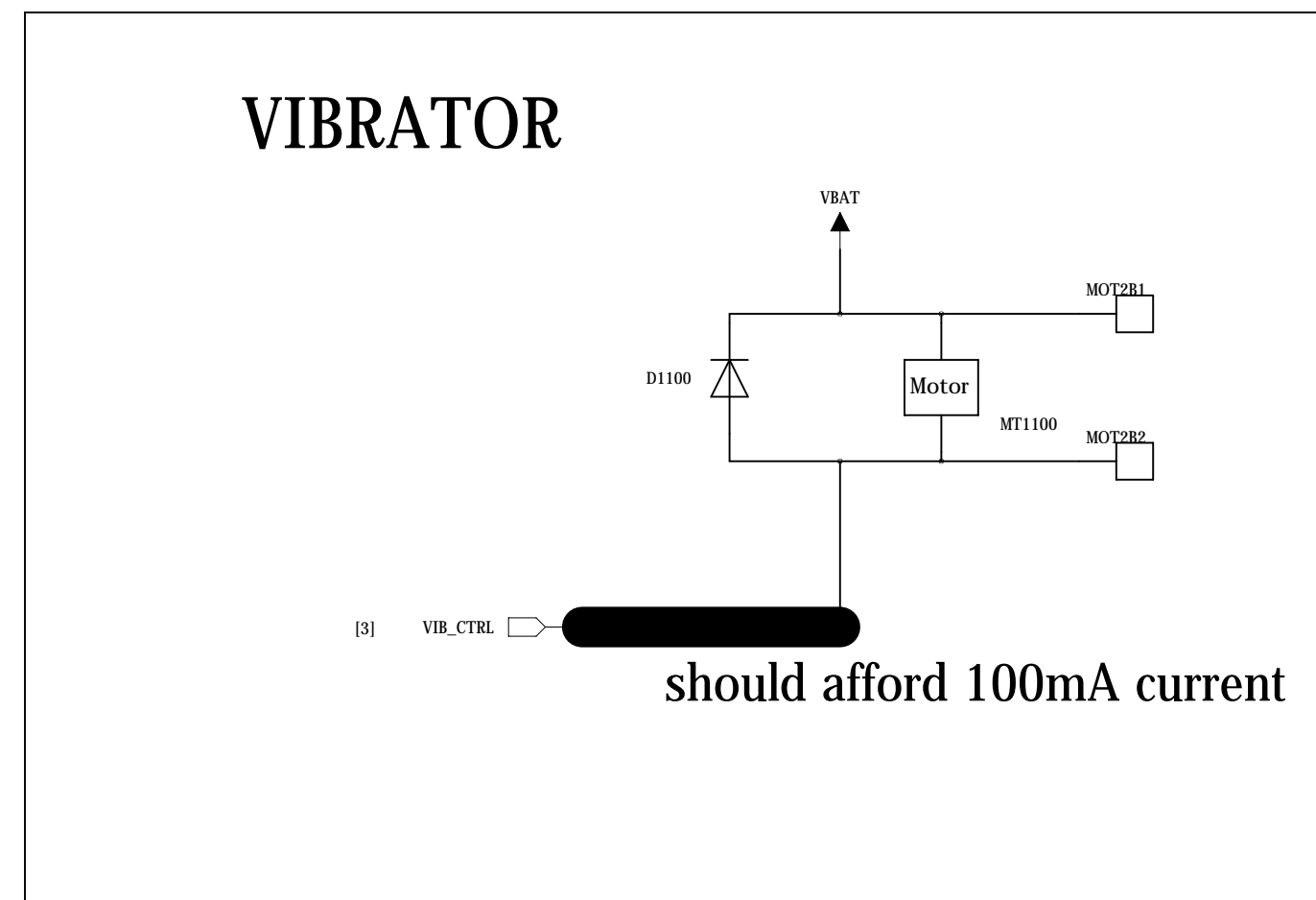
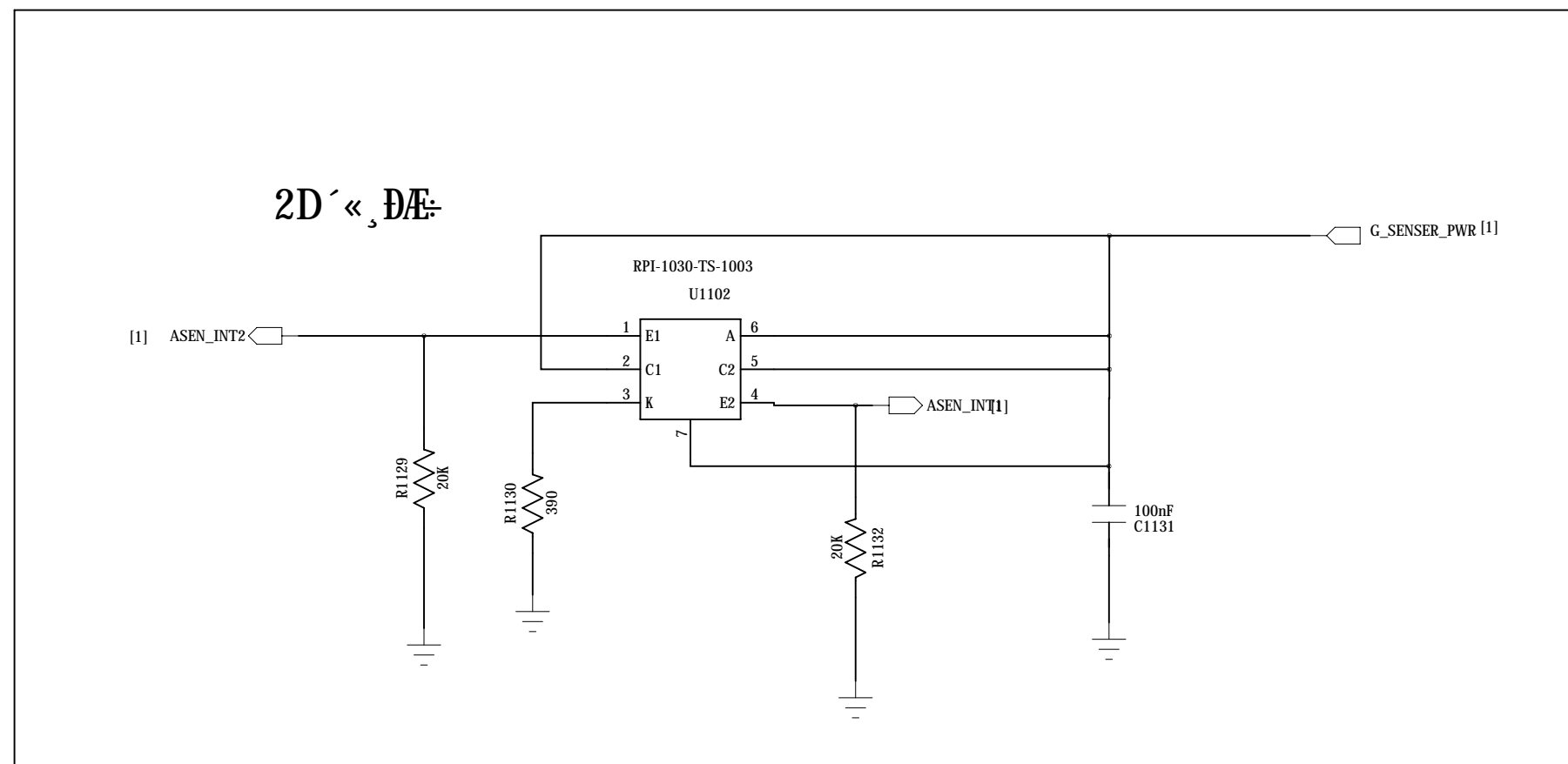

Freecom		
Project№°	<project>	Design by№° <Design>
Title№°	<title>	Check by№° <check>
REV№°	<REV>	Approve№° <appr>
File NO.№°	<file no>	sheet: 11/ 13

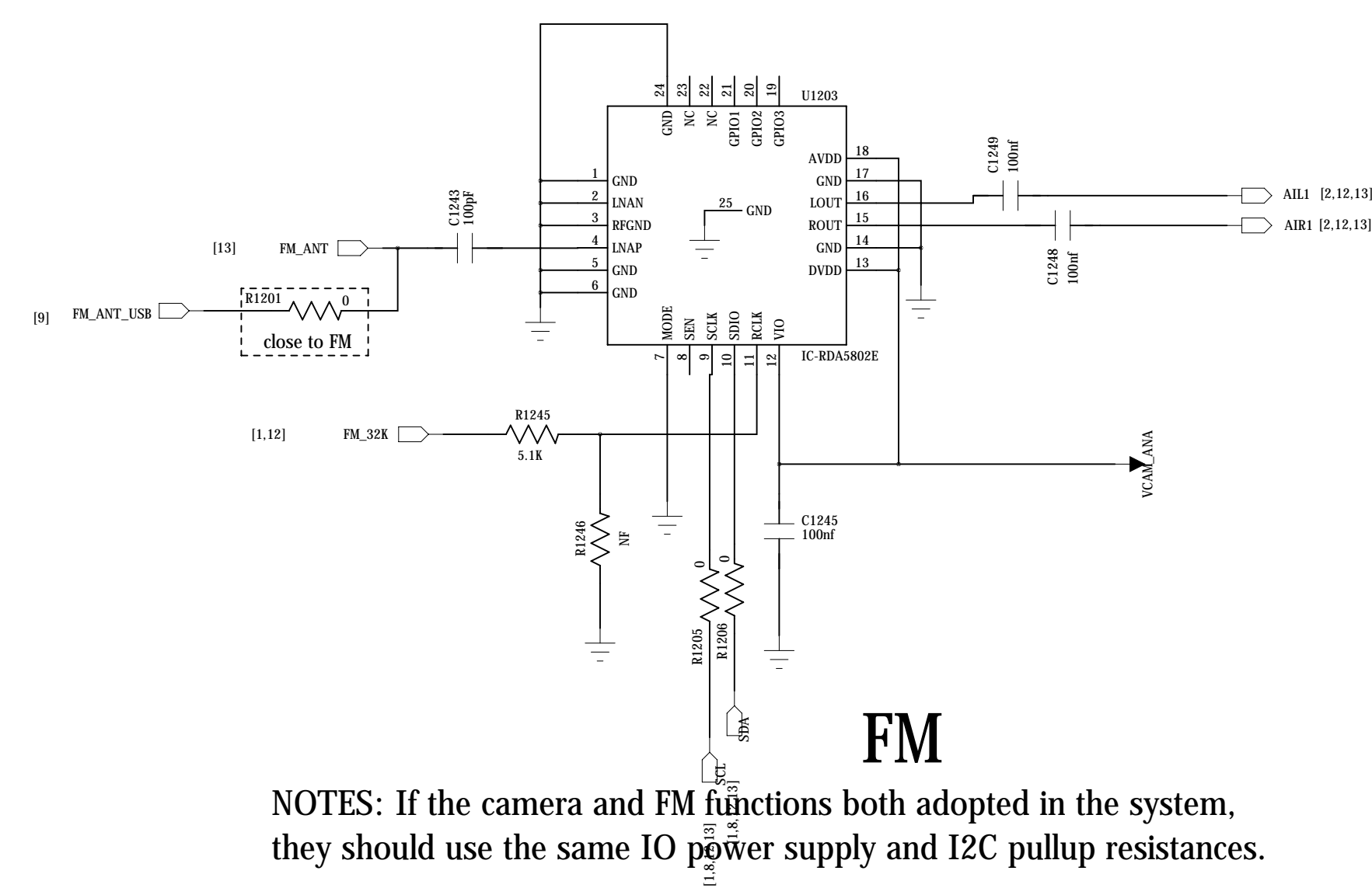
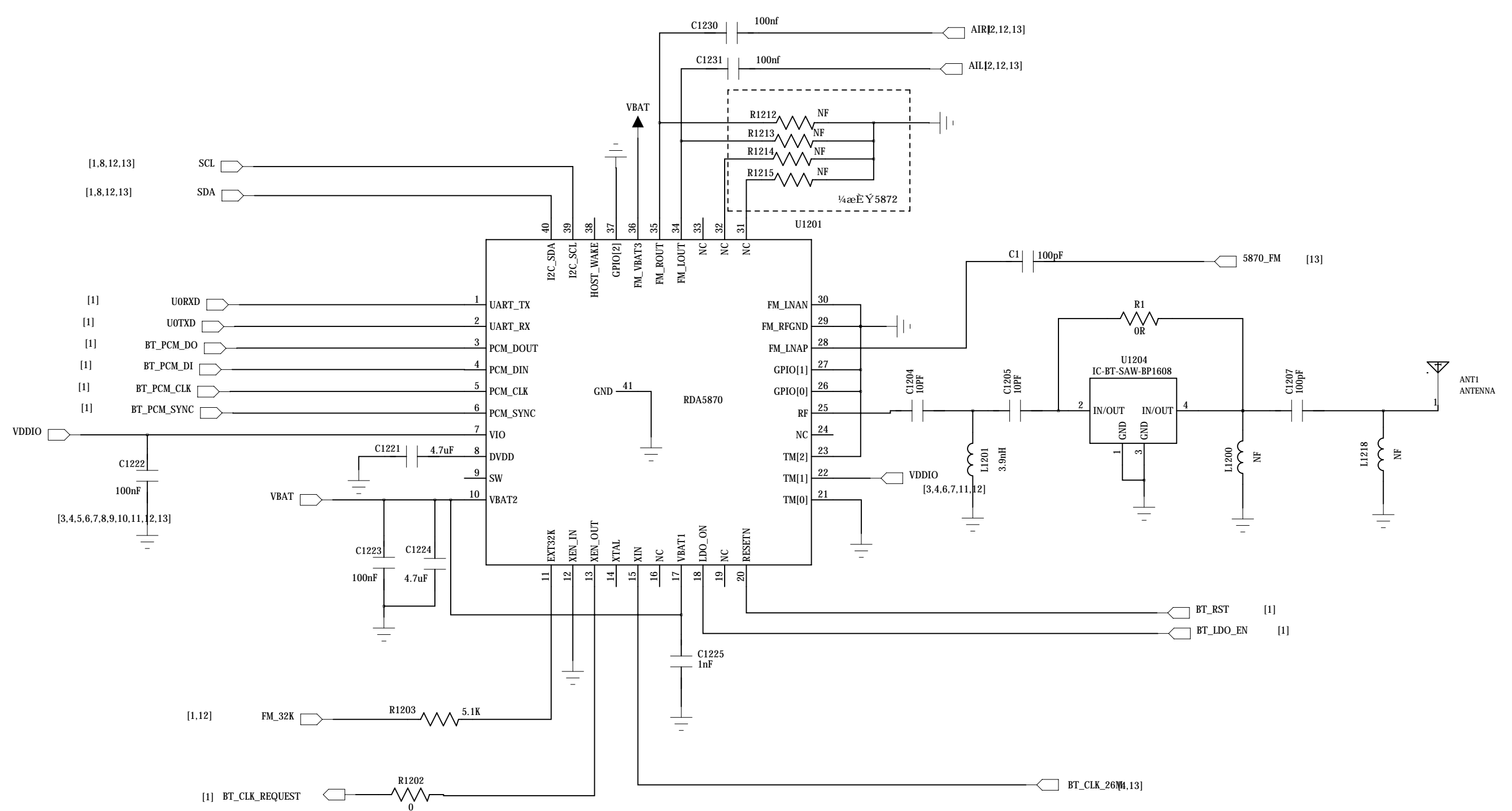

### FM

NOTES: If the camera and FM functions both adopted in the system, they should use the same IO power supply and I2C pullup resistances.

Freecom		
Project#°	<project>	Design by#° <Design>
Title#°	<title>	Check by#° <check>
REV#°	<REV>	Approve#° <appr>
File NO.#°	<file no>	sheet: 12/ 13

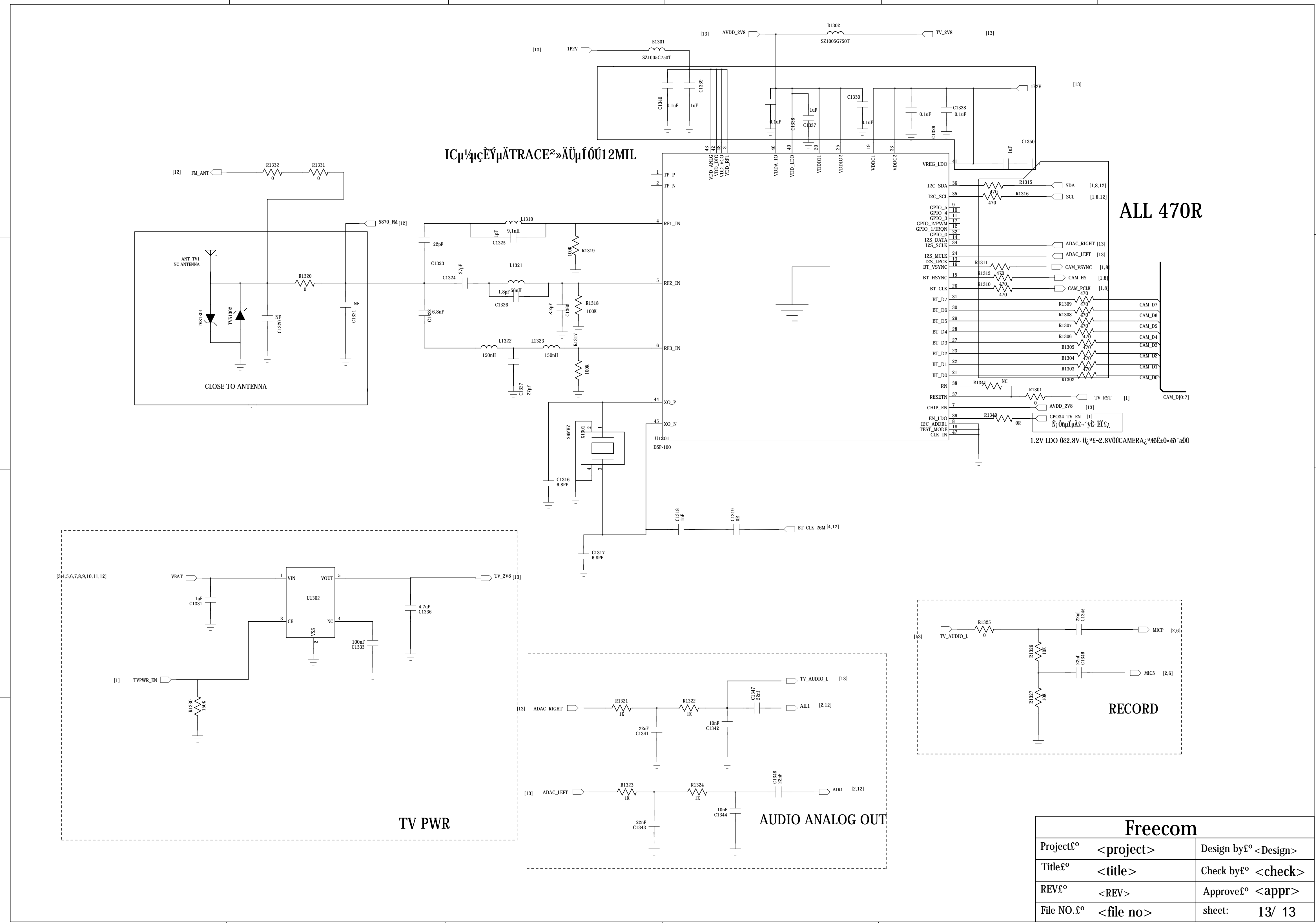

Freecom	
Project#°	<project> Design by#° <Design>
Title#°	<title> Check by#° <check>
REV#°	<REV> Approve#° <appr>
File NO.#°	<file no> sheet: 13/ 13