



Hearing Aid Compatibility (HAC) RF Emission Test Report

Product Name : GSM MOBILE PHONE

Model No. : BOOM, K100

Applicant : CLC Hong Kong Limited

Address : 907 Hart Avenue Plaza, 5-9A Hart Avenue,
Tsim Sha Tsui, Kowloon, Hong

Date of Receipt : 2012/02/13

Issued Date : 2012/03/14

Report No. : 122257R-HPUSP09V01

Report Version : V0.2-Draft



Testing Laboratory

0914

The test results relate only to the samples tested.

The test report shall not be reproduced except in full without the written approval of Quietek Corporation.

Test Report Certification

Issued Date: 2012/03/14

Report No.:122257R-HPUSP09V01



Product Name : GSM MOBILE PHONE
 Applicant : CLC Hong Kong Limited
 Address : 907 Hart Avenue Plaza, 5-9A Hart Avenue, Tsim Sha Tsui,
 Kowloon, Hong
 Manufacturer : CLC Technology Co. Ltd.
 Model No. : BOOM, K100
 Trade Name : PLUM
 FCC ID : Y7WPLUMK100
 Applicable Standard : 47CFR § 20.19
 ANSI C63.19 2007
 M Category : M3
 Application Type : Certification

The test results relate only to the samples tested.
 The test report shall not be reproduced except in full without the written approval of Quietek Corporation.

Documented By : April Chen
 (Adm. Assistant / April Chen)

Tested By : wenlee
 (Engineer / Wen Lee)

Approved By : [Signature]
 (Manager / Vincent Lin)

TABLE OF CONTENTS

Description	Page
1. General Information.....	4
1.1 EUT Description	4
1.2 Test Environment	5
2. HAC Measurement System	6
2.1 DASYS System Description	6
2.2 HAC Probe	7
2.2.1 HAC E-Field Probe Specification.....	7
2.2.2 HAC H-Field Probe Specification	8
2.3 Boundary Detection Unit and Probe Mounting Device	8
2.4 DATA Acquisition Electronics (DAE) and Measurement Server	8
2.5 Robot.....	9
2.6 Light Beam Unit.....	9
2.7 Device Holder	10
2.8 Test Arch Phantom.....	10
3. System Check.....	11
3.1 Dipole Kit.....	11
3.2 System Check.....	12
3.3 System Check Results.....	12
4. Measurement Description	13
4.1 RF Emission Measurements Reference and Plane.....	13
4.2 Near-Field Emission Automated Test Flowchart.....	14
4.3 Test Procedure Description.....	15
4.4 Probe Modulation Factor (PMF).....	16
4.4.1 PMF Measurement Summary:	17
5. HAC RF Emission Limits.....	19
6. Test Equipment List.....	20
7. Measurement Uncertainty.....	21
8. Test Results	22
8.1 HAC RF Emission Test Results Summary.....	22
Appendix.....	23
Appendix A. HAC System Check Data	
Appendix B. HAC RF Emission Measurement Data	
Appendix C. Test Setup Photographs & EUT Photographs	
Appendix D. HAC Probe Calibration Data	
Appendix E. HAC Dipole Calibration Data	

1. General Information

1.1 EUT Description

Product Name	GSM MOBILE PHONE
Trade Name	PLUM
Model No.	BOOM, K100
FCC ID	Y7WPLUMK100
TX Frequency	824MHz~849MHz(GSM 850) 1850MHz ~1910MHz(PCS 1900)
RX Frequency	869MHz~894MHz(GSM 850) 1930MHz ~1990MHz(PCS 1900)
Device Category	Portable
RF Exposure Environment	Uncontrolled
Max. Peak Output Power (Conducted)	GSM 850: 31.87dBm PCS 1900: 29.98dBm

1.2 Test Environment

Ambient conditions in the laboratory:

Test Date: Feb 16, 2012

Items	Required	Actual
Temperature (°C)	18-25	21.1
Humidity (%RH)	30-70	50

Site Description:

Accredited by TAF
Accredited Number: 0914
Effective through: December 12, 2014

Site Name: Quietek Corporation

Site Address: No. 5-22, Rueishu Keng, Linkou Dist.,
New Taipei City 24451,
Taiwan. R.O.C.
TEL: 886-2-8601-3788 / FAX: 886-2-8601-3789
E-Mail: service@quietek.com

2. HAC Measurement System

2.1 DASY5 System Description

The purpose of the Hearing Aid Compatibility extension is to enable measurements of the near electric and magnetic fields generated by wireless communication devices in the region controlled for use by a hearing aid in accordance with ANSI C63.19-2006 and ANSI C63.19-2007. Electric and magnetic fields of a wireless device are scanned with free-space probes (e.g., ER3DVx and H3DVx) in a 5 by 5 cm area parallel above the acoustic point. The scanning distance from the device surface depends on the standard version (for ANSI C63.19-2006 10mm from the closest probe sensor part, and for ANSI C63.19-2007 15mm from the probe sensor center). The maximum field values in 9 sub-grids of the electrical and a magnetic field scan are evaluated automatically according to the rules defined in the standard and result in a specific “M-class”.

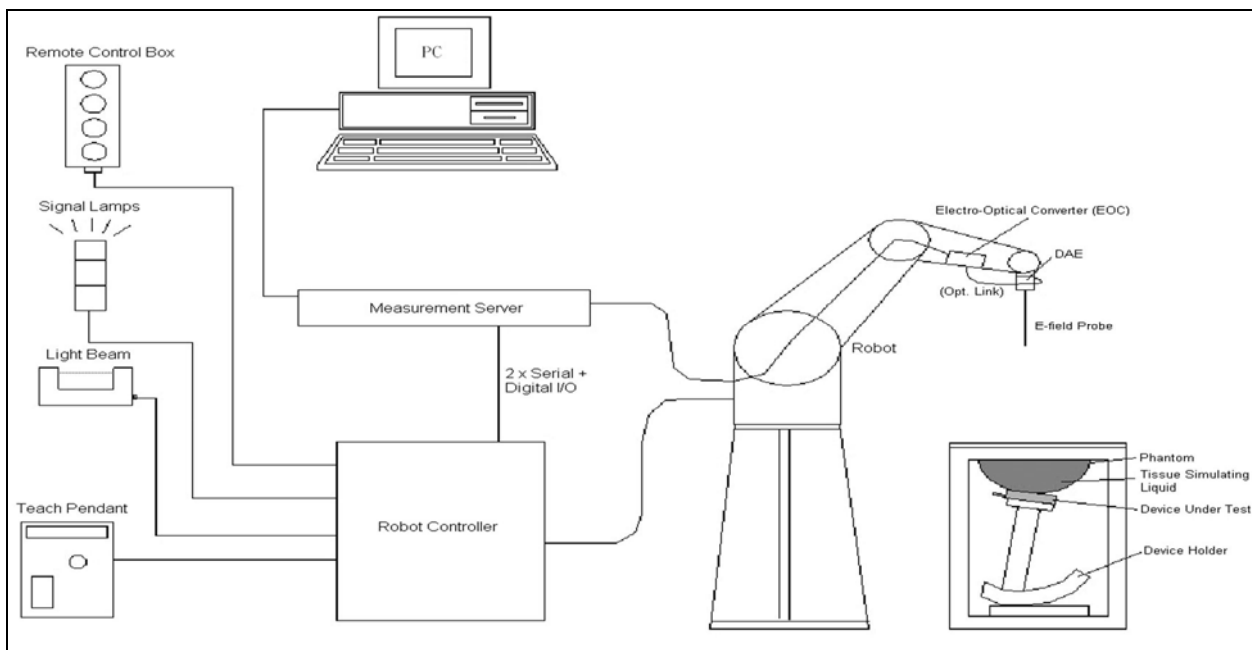

The DASY5 system for performing compliance tests consists of the following items:

- A standard high precision 6-axis robot with controller, teach pendant and software. An arm extension for accommodating the data acquisition electronics (DAE).
- A data acquisition electronics (DAE) which performs the signal amplification, signal multiplexing, AD-conversion, offset measurements, mechanical surface detection, collision detection, etc. The unit is battery powered with standard or rechargeable batteries. The signal is optically transmitted to the EOC.
- The Electro-optical converter (EOC) performs the conversion from optical to electrical

signals for the digital communication to the DAE. To use optical surface detection, a special version of the EOC is required. The EOC signal is transmitted to the measurement server.

- The Light Beam used is for probe alignment. This improves the (absolute) accuracy of the probe positioning.
- A computer running WinXP and the DASY5 software.
- Remote control and teach pendant as well as additional circuitry for robot safety such as warning lamps, etc.
- The Arch phantom, the device holder and other accessories according to the targeted measurement.

2.2 HAC Probe

The E-field free space probe (ER3DV6) as well as the H-feld probe (H3DVx) needs to be calibrated for the respective signal such that the true time-average RMS value is obtained independent of the field strength. The calibration data are in Appendix D.

2.2.1 HAC E-Field Probe Specification

Model	ER3DV6	
Construction	One dipole parallel, two dipoles normal to probe axis Built-in shielding against static charges	
Frequency	100MHz to 6GHz; Linearity: ± 0.2dB (100MHz to 3GHz)	
Directivity	± 0.2dB in air (rotation around probe axis) ± 0.4dB in air (rotation normal to probe axis)	
Dynamic Range	2V/m to 1000V/m (M3 or better device readings fall well below diode compression point) Linearity: ± 0.2dB	
Dimensions	Overall length: 330mm (Tip: 16mm) Tip diameter: 8mm (Body: 12mm) Distance from probe tip to dipole centers: 2.5mm	

2.2.2 HAC H-Field Probe Specification

Model	H3DV6	
Construction	Three concentric loop sensors with 3.8mm loop diameters Resistively loaded detector diodes for linear response Built-in shielding against static charges	
Frequency	200MHz to 3GHz (absolute accuracy $\pm 6.0\%$, $k = 2$); Output linearized	
Directivity	$\pm 0.25\text{dB}$ (spherical isotropy error)	
Dynamic Range	10mA/m to 2A/m at 1GHz (M3 or better device readings fall well below diode compression point)	
Dimensions	Overall length: 330mm (Tip: 40mm) Tip diameter: 6mm (Body: 12mm) Distance from probe tip to dipole centers: 3mm	

2.3 Boundary Detection Unit and Probe Mounting Device

The DASY probes use a precise connector and an additional holder for the probe, consisting of a plastic tube and a flexible silicon ring to center the probe. The connector at the DAE is flexibly mounted and held in the default position with magnets and springs. Two switching systems in the connector mount detect frontal and lateral probe collisions and trigger the necessary software response.



2.4 DATA Acquisition Electronics (DAE) and Measurement Server

The data acquisition electronics (DAE) consists of a highly sensitive electrometer-grade preamplifier with auto-zeroing, a channel and gain-switching multiplexer, a fast 16 bit AD-converter and a command decoder and control logic unit.

Transmission to the measurement server is accomplished through an optical downlink for data and status information as well as an optical uplink for commands and the clock.

The input impedance of the DAE4 is 200M Ohm; the inputs are symmetrical and floating. Common mode rejection is above 80dB.



The DASY5 measurement server is based on a PC/104 CPU board with a 400MHz intel ULV Celeron, 128MB chipdisk and 128MB RAM. The necessary circuits for communication with the DAE electronics box, as well as the 16 bit AD converter system for optical detection and digital I/O interface are contained on the DASY5 I/O board, which is directly connected to the PC/104 bus of the CPU board.



2.5 Robot

The DASY5 system uses the high precision robots TX60L type out of the newer series from Stäubli SA (France). For the 6-axis controller DASY5 system, the CS8C robot controller version from Stäubli is used.

The XL robot series have many features that are important for our application:

- High precision (repeatability 0.02 mm)
- High reliability (industrial design)
- Jerk-free straight movements
- Low ELF interference (the closed metallic construction shields against motor control fields)
- 6-axis controller



2.6 Light Beam Unit

The light beam switch allows automatic "tooling" of the probe. During the process, the actual position of the probe tip with respect to the robot arm is measured, as well as the probe length and the horizontal probe offset. The software then corrects all movements, such that the robot coordinates are valid for the probe tip.

The repeatability of this process is better than 0.1 mm. If a position has been taught with an aligned probe, the same position will be reached with another aligned probe within 0.1 mm, even if the other probe has different dimensions. During probe rotations, the probe tip will keep its actual position.



2.7 Device Holder

The HAC device holder is made from SPEAG. The holder supports accurate and reliable positioning of any phone effect on near field $\pm 0.5\text{dB}$. It is used to adjust DUT to suitable position.

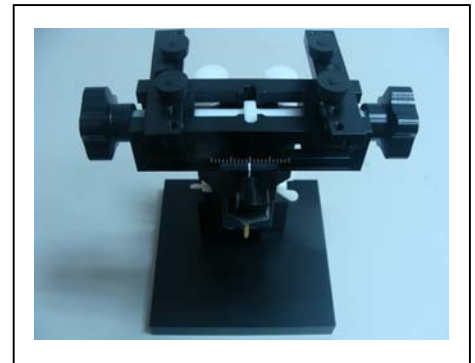

2.8 Test Arch Phantom

The HAC Test Arch phantom is used with several sections, each considering the different vertical distances of the DUT or the dipole as well as the different sensor offsets of the E- and H-Field probes. The Test Arch phantom V4.8 includes a single predefined RF phantom section (V4.9 also a TCoil section).

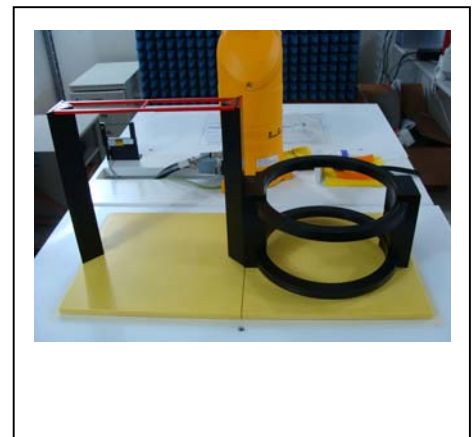



Model	Arch Phantom V 4.9
Dimensions	370 x 370 x 370mm

3. System Check

3.1 Dipole Kit

Model	CD835V3	
Frequency Band	800 ~ 960MHz (free space)	
Return Loss	> 15dB	
Calibration	835MHz (Appendix E)	
Power Capability	50W continuous	
Dimensions	Length: 166mm Height: 330mm	

Model	CD1880V3	
Frequency Band	1710 ~ 2000MHz (free space)	
Return Loss	> 18dB	
Calibration	1880MHz (Appendix E)	
Power Capability	50W continuous	
Dimensions	Length: 80.8mm Height: 330mm	

Model	CD2450V3	
Frequency Band	2250 ~ 2650MHz (free space)	
Return Loss	> 18dB	
Calibration	2450MHz (Appendix E)	
Power Capability	50W continuous	
Dimensions	Length: 59.9mm Height: 330mm	

3.2 System Check

The manufacturer calibrates the probes annually. The HAC measurements of the device were done within 24 hours of system accuracy verification, which was done using calibration dipoles. Unmodulated continuous wave of power level of 20dBm was supplied to a dipole antenna placed under Test Arch. The measurement probes are positioned over the illuminated dipole at 10mm distance from the top surface of the dipole element to the calibration reference point of the sensor, defined by the probe manufacturer.

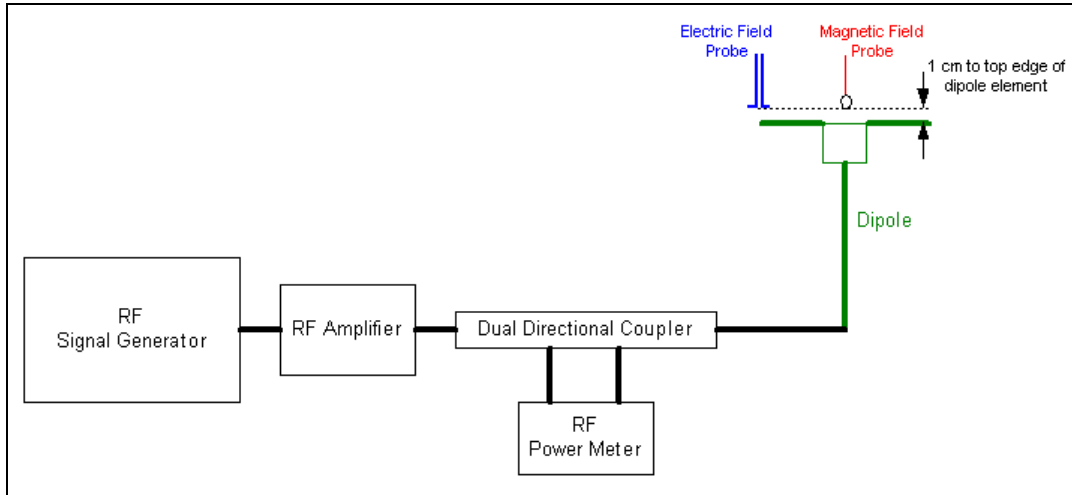

3.3 System Check Results

HAC System Check					
Frequency [MHz]	Input Power (dBm)	Target E-Field (V/m)	Measured E-Field (V/m)	Deviation (%)	Date
835	20	164	152.0	-7.3	2012/02/16
1880	20	142.4	132.6	-6.9	2012/02/16
Frequency [MHz]	Input Power (dBm)	Target H-Field (A/m)	Measured H-Field (A/m)	Deviation (%)	Date
835	20	0.470	0.44	-6.4	2012/02/16
1880	20	0.476	0.44	-7.6	2012/02/16

The measured values (E-field and H-field) were compared with the values provided by the probe manufacturer and must within the allowed tolerance of 25%

4. Measurement Description

4.1 RF Emission Measurements Reference and Plane

The figure as below illustrates the references and reference plane that shall be used in the EUT emissions measurement:

- The grid is 5 cm by 5 cm area that is divided into 9 evenly sized blocks or sub-grids.
- The grid is centered on the audio frequency output transducer (speaker) of the EUT.
- The grid is in a reference plane, which is defined as the planar area that contains the highest point in the area of the phone that normally rests against the user's ear. It is parallel to the centerline of the receiver of the EUT and is defined by the points of the receiver-end of the EUT, which, in normal handset use, rest against the ear.
- The measurement plane is parallel to, and 1.5 cm in front of, the reference plane.

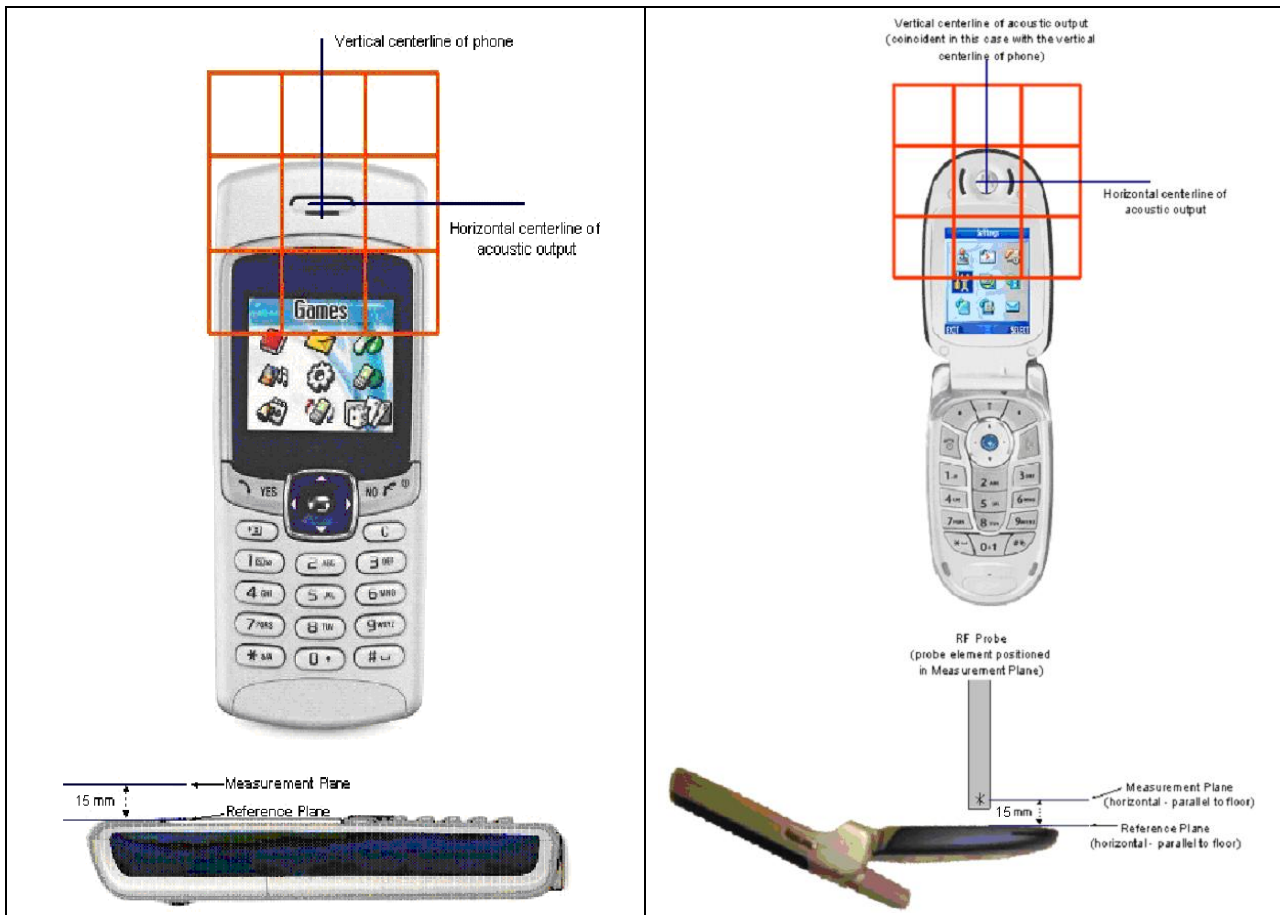

4.2 Near-Field Emission Automated Test Flowchart

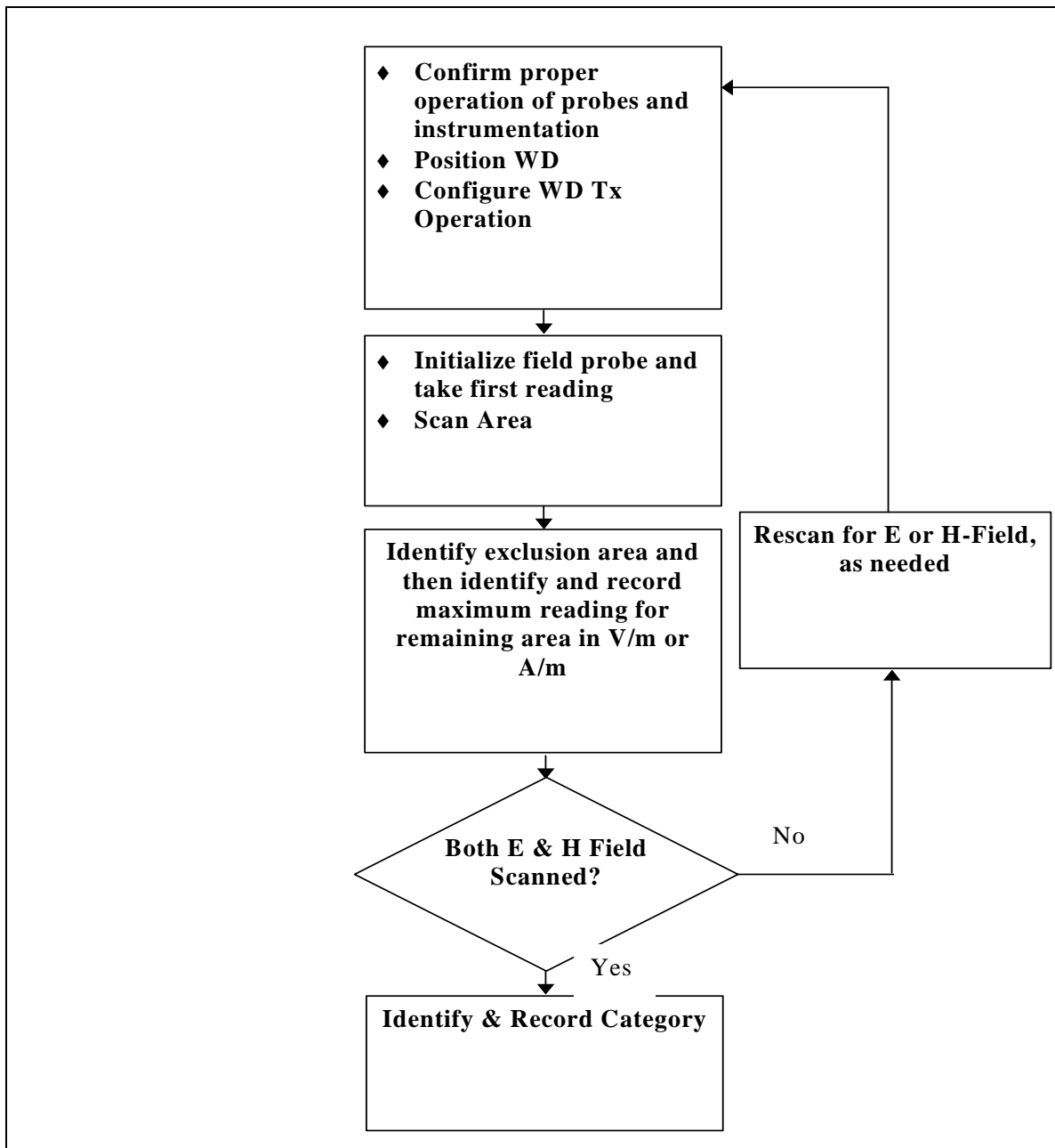

4.3 Test Procedure Description

The following illustrate a typical RF emission test scan over a wireless communication device:

1. Proper operation of the field probe, probe measurement system, other instrumentation, and the positioning system was confirmed.
2. Position the WD in its intended test position, acoustic output point of the device perpendicular to the field probe.
3. The WD operation for maximum rated RF output power was configured and confirmed with the base station simulator, at the test channel and other normal operating parameters as intended for the test. Ensure battery is fully charged before each test.
4. The center sub-grid was centered over the center of the acoustic output (also audio band magnetic output, if applicable). The WD audio output was positioned tangent (as physically possible) to the measurement plane.
5. A surface calibration was performed before each setup change to ensure repeatable spacing and proper maintenance of the measurement plane using the HAC arch.
6. The measurement system measured the field strength at the reference location.
7. Measurements at 2mm or 5mm increments in the 5x 5cm region were performed at a distance 15 mm from the center point of the probe measurement element to the WD. A 360° rotation about the azimuth axis at the maximum interpolated position was measured. For the worst-case condition, the peak reading from this rotation was used in re-evaluating the HAC category.
8. The system performed a drift evaluation by measuring the field at the reference location.
9. Steps 1-8 were done for both the E and H-Field measurements

4.4 Probe Modulation Factor (PMF)

A calibration was made of the modulation response of the probe and its instrumentation chain. This calibration was performed with the field probe, attached to its instrumentation. The response of the probe system to a CW field at the frequency of interest is compared to its response to a modulated signal with equal peak amplitude to that of a CW signal. The field level of the test signals shall be more than 10 dB above the ambient level and the noise floor of the instrumentation being used. The ratio of the CW reading to that taken with a modulated reading was applied to the DUT measurements.

This was done using the following procedures:

1. Fixing the probe in a set location relative to a field generated device, such as a reference dipole antenna, as illustrated in the system check procedure.
2. Illuminate the probe with a CW signal at the intended measurement frequency.
3. Record the reading of the probe measurement system of the CW signal.
4. Determine the level of the CW signal being used to drive the field generating device.
5. Substitute a signal using the same modulation as that used by the intended WD for the CW signal.
6. Set the peak amplitude of the modulated signal to equal the amplitude of CW signal.
7. Record the reading of the probe measurement system of the modulated signal.
8. The ratio of the CW to modulated signal reading is the modulation factor.
9. Steps 1-8 were repeated at all frequency bands and for both E and H field probes.

4.4.1 PMF Measurement Summary:

Frequency	Functions	E-Field	H-Field	PMF	
		V/m	A/m	E-Field	H-Field
835MHz	CW	171.9	0.458		
835MHz	AM	104.1	0.288	1.65	1.59
835MHz	GSM	63.68	0.169	2.70	2.71
1880MHz	CW	155	0.484		
1880MHz	AM	99.41	0.312	1.56	1.55
1880MHz	GSM	59.02	0.174	2.63	2.78

CW 836MHz

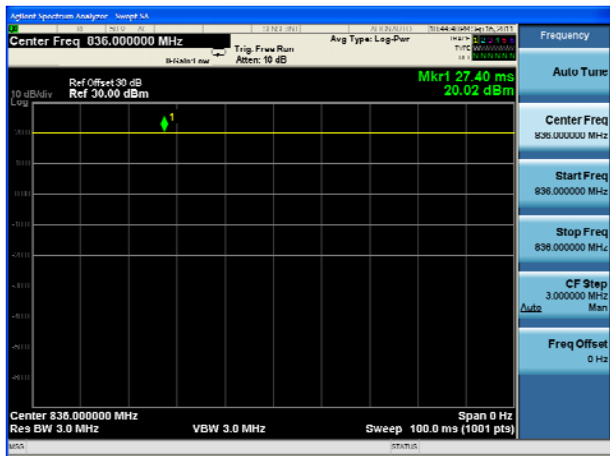

CW 1800MHz



AM 836MHz

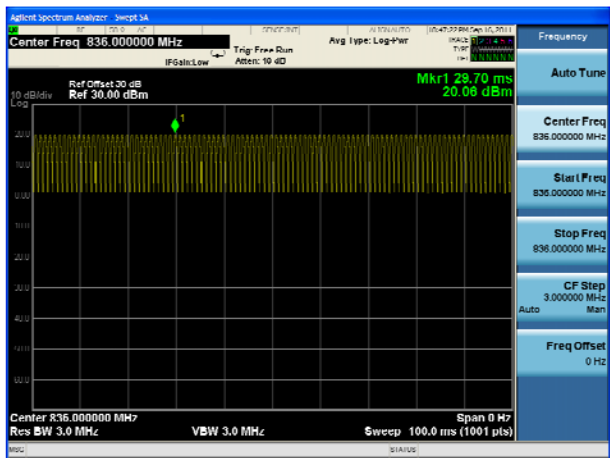

AM 1800MHz

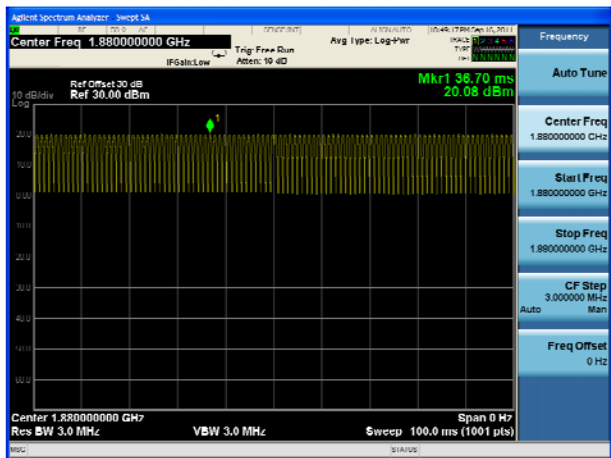

GSM 836MHz

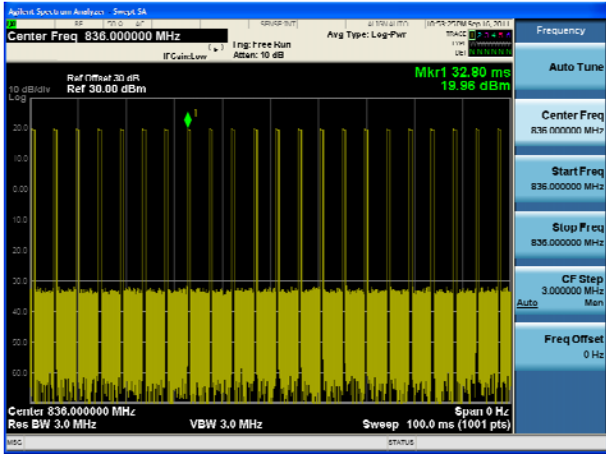

GSM 1880MHz

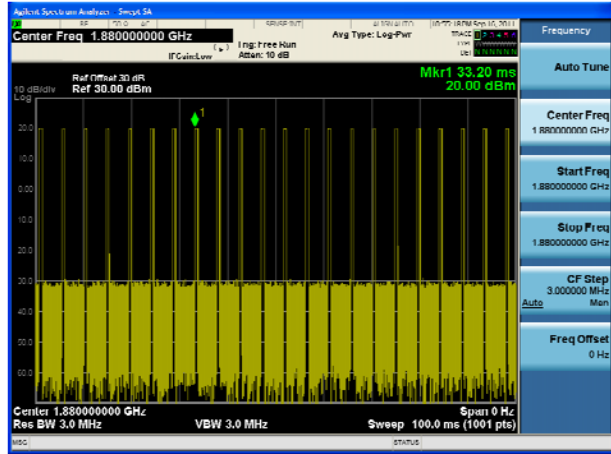

5. HAC RF Emission Limits

The ANSI Standard presents performance requirements for acceptable interoperability of hearing aids with wireless communications devices. When these parameters are met, a hearing aid operates acceptably in close proximity to a wireless communications device.

TELEPHONE RF PARAMETERS < 960MHz					
CATEGORY NEAR FIELD	AWF	E-FIELD EMISSION CW		H-FIELD EMISSION CW	
		(dBV/m)	(V/m)	(dBA/m)	(A/m)
M1	0	56.0 to 61.0	631.0 to 1122.0	5.6 to 10.6	1.91 to 3.39
	-5	53.5 to 58.5	473.2 to 841.4	3.1 to 8.1	1.43 to 2.54
M2	0	51.0 to 56.0	354.8 to 631.0	0.6 to 5.6	1.07 to 1.91
	-5	48.5 to 53.5	266.1 to 473.2	-1.9 to 3.1	0.80 to 1.43
M3	0	46.0 to 51.0	199.5 to 354.8	-4.4 to 0.6	0.60 to 1.07
	-5	43.5 to 48.5	149.6 to 266.1	-6.9 to -1.9	0.45 to 0.80
M4	0	< 46.0	< 199.5	< -4.4	< 0.60
	-5	< 43.5	< 149.6	< -6.9	< 0.45
TELEPHONE RF PARAMETERS >960MHz					
M1	0	46.0 to 51.0	199.5 to 354.8	-4.4 to 0.6	0.60 to 1.07
	-5	43.5 to 48.5	149.6 to 266.1	-6.9 to -1.9	0.45 to 0.80
M2	0	41.0 to 46.0	112.2 to 199.5	-9.4 to -4.4	0.34 to 0.60
	-5	48.5 to 53.5	84.1 to 149.6	-11.9 to -6.9	0.25 to 0.45
M3	0	36.0 to 41.0	63.1 to 112.2	-14.4 to -9.4	0.19 to 0.34
	-5	33.5 to 38.5	47.3 to 84.1	-16.9 to -11.9	0.14 to 0.25
M4	0	< 36.0	< 63.1	< -14.4	< 0.19
	-5	< 33.5	< 47.3	< -16.9	< 0.14

The following AWF factors were used for the standard transmission protocols:

ARTICULATION WEIGHING FACTOR (AWF)		
STANDARD	TECHNOLOGY	AWF (dB)
TIA/EIA/IS-2000	CDMA	0
TIA/EIA-136	TDMA (50Hz)	0
iDENTM	TDMA (22 and 11Hz)	0
J-STD-007	GSM (217)	-5
T1/T1P1/3GPP	UMTS (WCDMA)	0

6. Test Equipment List

Instrument	Manufacturer	Model No.	Serial No.	Last Calibration	Next Calibration
Stäubli Robot TX60L	Stäubli	TX60L	F09/5BL1A1/A06	2009/05/18	only once
Controller	Speag	CS8c	N/A	2009/05/18	only once
Test Arch Phantom	Speag	SD HAC P01 BB	1118	N/A	N/A
Speaq Reference Dipole 835MHz	Speaq	CD835V3	1135	2011/05/17	2013/05/16
Speaq Reference Dipole 1900MHz	Speaq	CD1880V3	1117	2011/05/17	2013/05/16
SAM Twin Phantom	Speag	QD000 P40 CA	Tp 1515	N/A	N/A
Device Holder	Speag	N/A	N/A	N/A	N/A
Data Acquisition Electronic	Speag	DAE4	1207	2011/05/19	2012/05/18
E-Field Probe	Speag	ER3DV6	2466	2011/05/18	2012/05/17
H-Field Probe	Speag	H3DV6	6288	2011/05/23	2012/05/22
SAR Software	Speag	DASY52	Version 52.8 (0)	N/A	N/A
Aprél Dipole Spaccer	Aprél	ALS-DS-U	QTK-295	N/A	N/A
Power Amplifier	Mini-Circuit	ZHL-42	D051404-20	N/A	N/A
Directional Coupler	Agilent	778D-012	50550	N/A	N/A
Universal Radio Communication Tester	R&S	CMU 200	104846	2011/05/20	2012/05/19
Vector Network	Anritsu	MS4623B	992801	2011/07/21	2012/07/20
Signal Generator	Anritsu	MG3694A	041902	2011/08/02	2012/08/01
Power Meter	Anritsu	ML2487A	6K00001447	2011/12/01	2012/11/30
Wide Bandwidth Sensor	Anritsu	MA2491	030677	2011/12/01	2012/11/30

7. Measurement Uncertainty

HAC Uncertainty Budget According to ANSI C63.19							
Error Description	Uncertainty value	Prob. Dist.	Div.	(c_i) E	(c_i) H	Std. Unc. E	Std. Unc. H
Measurement System							
Probe Calibration	±5.1 %	N	1	1	1	±5.1 %	±5.1 %
Axial Isotropy	±4.7 %	R	$\sqrt{3}$	1	1	±2.7 %	±2.7 %
Sensor Displacement	±16.5 %	R	$\sqrt{3}$	1	0.145	±9.5 %	±1.4 %
Test Arch	±7.2 %	R	$\sqrt{3}$	1	0	±4.1 %	±0.0 %
Linearity	±4.7 %	R	$\sqrt{3}$	1	1	±2.7 %	±2.7 %
Scaling to Peak Envelope Power	±0.0 %	R	$\sqrt{3}$	1	1	±0.0 %	±0.0 %
System Detection Limit	±1.0 %	R	$\sqrt{3}$	1	1	±0.6 %	±0.6 %
Readout Electronics	±0.3 %	N	1	1	1	±0.3 %	±0.3 %
Response Time	±0.8 %	R	$\sqrt{3}$	1	1	±0.5 %	±0.5 %
Integration Time	±2.6 %	R	$\sqrt{3}$	1	1	±1.5 %	±1.5 %
RF Ambient Conditions	±3.0 %	R	$\sqrt{3}$	1	1	±1.7 %	±1.7 %
RF Reflections	±12.0 %	R	$\sqrt{3}$	1	1	±6.9 %	±6.9 %
Probe Positioner	±1.2 %	R	$\sqrt{3}$	1	0.67	±0.7 %	±0.5 %
Probe Positioning	±4.7 %	R	$\sqrt{3}$	1	0.67	±2.7 %	±1.8 %
Extrap. and Interpolation	±1.0 %	R	$\sqrt{3}$	1	1	±0.6 %	±0.6 %
Test Sample Related							
Device Positioning Vertical	±4.7 %	R	$\sqrt{3}$	1	0.67	±2.7 %	±1.8 %
Device Positioning Lateral	±1.0 %	R	$\sqrt{3}$	1	1	±0.6 %	±0.6 %
Device Holder and Phantom	±2.4 %	R	$\sqrt{3}$	1	1	±1.4 %	±1.4 %
Power Drift	±5.0 %	R	$\sqrt{3}$	1	1	±2.9 %	±2.9 %
Phantom and Setup Related							
Phantom Thickness	±2.4 %	R	$\sqrt{3}$	1	0.67	±1.4 %	±0.9 %
Combined Std. Uncertainty						±15.2 %	±10.8 %
Expanded Std. Uncertainty on Power						±30.4 %	±21.6 %
Expanded Std. Uncertainty on Field						±15.2 %	±10.8 %

8. Test Results

8.1 HAC RF Emission Test Results Summary

HAC MEASUREMENT						
Product: GSM MOBILE PHONE						
Test Mode: E-Field						
Test Band	Antenna Position	Frequency		Conducted Power (dBm)	Peak E-Field(V/m)	Rating
		Channel	MHz			
850	Fixed	128	824.2	31.87	96.96	M4
850	Fixed	189	836.4	31.52	78.73	M4
850	Fixed	251	848.8	31.40	65.09	M4
1900	Fixed	512	1850.2	29.60	56.12	M3
1900	Fixed	661	1880	29.79	68.09	M3
1900	Fixed	810	1909.8	29.98	80.15	M3
Test Mode: H-Field						
Test Band	Antenna Position	Frequency		Conducted Power (dBm)	Peak H-Field(A/m)	Rating
		Channel	MHz			
850	Fixed	128	824.2	31.87	0.33	M4
850	Fixed	189	836.4	31.52	0.29	M4
850	Fixed	251	848.8	31.40	0.24	M4
1900	Fixed	512	1850.2	29.60	0.16	M3
1900	Fixed	661	1880	29.79	0.21	M3
1900	Fixed	810	1909.8	29.98	0.25	M3

Appendix**Appendix A. HAC System Check Data****Appendix B. HAC RF Emission Measurement Data****Appendix C. Test Setup Photographs & EUT Photographs****Appendix D. HAC Probe Calibration Data****Appendix E. HAC Dipole Calibration Data**

Appendix A. HAC System Check Data

Test Laboratory: QuieTek

Date/Time: 2012/2/16

HAC E-field Cal 835

DUT: HAC-Dipole 835 MHz; Type: D835V3

Communication System: CW; Frequency: 835 MHz; Communication System PAR: 0 dB

Phantom section: RF Section

Measurement Standard: DASYS (IEEE/IEC/ANSI C63.19-2007)

DASY Configuration:

- Probe: ER3DV6 - SN2466; ConvF(1, 1, 1); Calibrated: 2010/5/20
- Sensor-Surface: (Fix Surface)
- Electronics: DAE4 Sn1207; Calibrated: 2011/5/19
- Phantom: HAC Test Arch with AMCC; Type: SD HAC P01 BA
- DASYS 52.8.0(692); SEMCAD X 14.6.4(4989)

Dipole E-Field measurement/E Scan - measurement distance from the probe sensor center to CD835 Dipole = 10mm/Hearing Aid Compatibility

Test (41x361x1): Measurement grid: dx=5mm, dy=5mm

Device Reference Point: 0, 0, -6.3 mm

Reference Value = 103.5 V/m; Power Drift = -0.01 dB

PMF = 1.000

E-field emissions = 156.9 V/m

Near-field category: M4 (AWF 0 dB)

PMF scaled E-field

Grid 1 M4 143.6 V/m	Grid 2 M4 147.0 V/m	Grid 3 M4 143.1 V/m
Grid 4 M4 82.65 V/m	Grid 5 M4 83.12 V/m	Grid 6 M4 81.63 V/m
Grid 7 M4 149.7 V/m	Grid 8 M4 156.9 V/m	Grid 9 M4 154.6 V/m

Cursor:

Total = 156.9 V/m

E Category: M4

Location: -1, 79, 4.7 mm

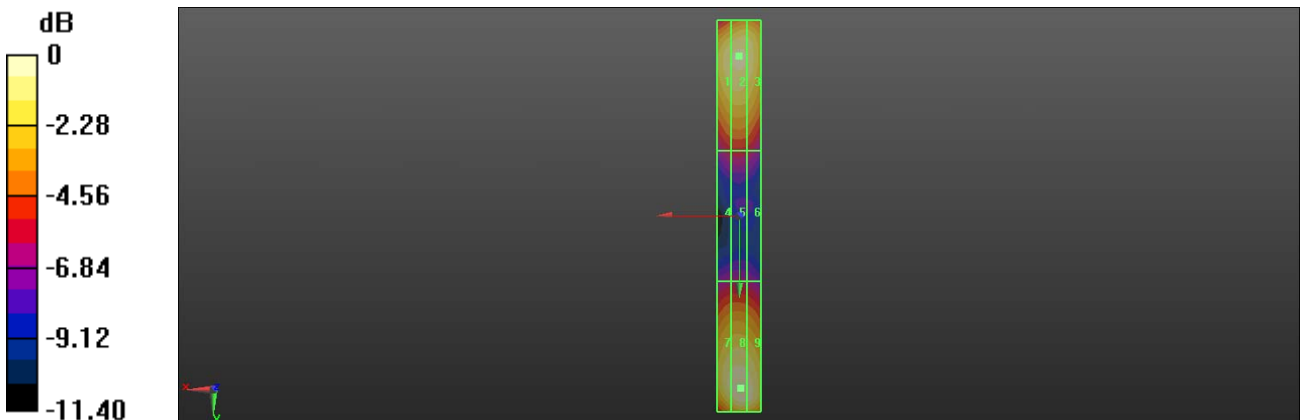

0 dB = 156.9V/m

Test Laboratory: QuieTek

Date/Time: 2012/2/16

HAC E-field Cal 1900

DUT: HAC Dipole 1880 MHz; Type: CD1880V3

Communication System: CW; Frequency: 1880 MHz; Communication System PAR: 0 dB

Phantom section: RF Section

Measurement Standard: DASYS (IEEE/IEC/ANSI C63.19-2007)

DASY Configuration:

- Probe: ER3DV6 - SN2466; ConvF(1, 1, 1); Calibrated: 2010/5/20
- Sensor-Surface: (Fix Surface)
- Electronics: DAE4 Sn1207; Calibrated: 2011/5/19
- Phantom: HAC Test Arch with AMCC; Type: SD HAC P01 BA
- DASYS 52.8.0(692); SEMCAD X 14.6.4(4989)

Dipole E-Field measurement/E Scan - measurement distance from the probe sensor center to CD1880 Dipole = 10mm/Hearing Aid Compatibility Test (41x181x1): Measurement grid: dx=5mm, dy=5mm

Device Reference Point: 0, 0, -6.3 mm

Reference Value = 150.7 V/m; Power Drift = -0.03 dB

PMF = 1.000

E-field emissions = 133.9 V/m

Near-field category: M2 (AWF 0 dB)

PMF scaled E-field

Grid 1 M2 127.2 V/m	Grid 2 M2 131.3 V/m	Grid 3 M2 129.0 V/m
Grid 4 M3 91.08 V/m	Grid 5 M3 92.98 V/m	Grid 6 M3 91.35 V/m
Grid 7 M2 127.1 V/m	Grid 8 M2 133.9 V/m	Grid 9 M2 132.5 V/m

Cursor:

Total = 133.9 V/m

E Category: M2

Location: -1, 38.5, 4.7 mm

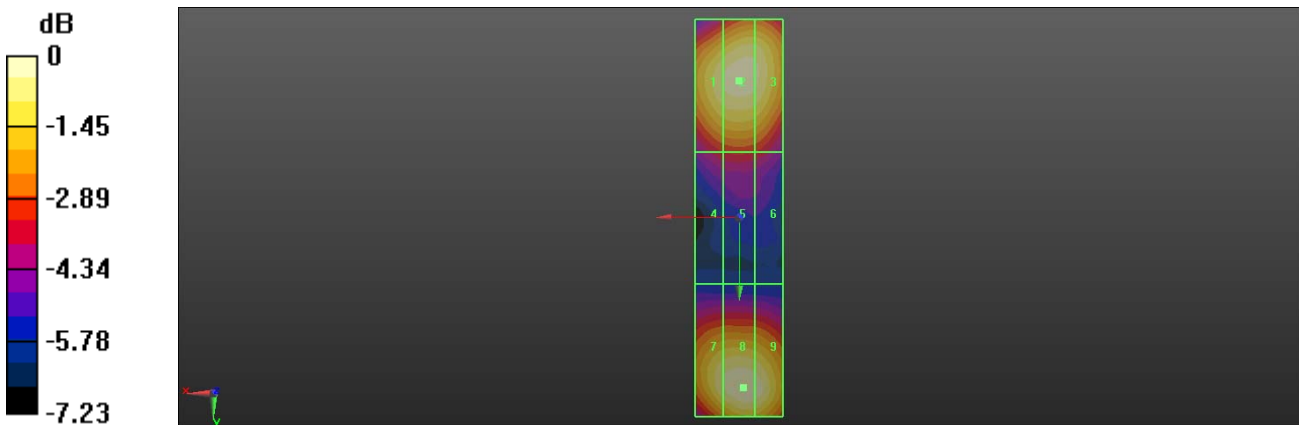

0 dB = 133.9V/m

Test Laboratory: QuieTek

Date/Time: 2012/2/16

HAC H-field Cal 835

DUT: HAC-Dipole 835 MHz; Type: D835V3

Communication System: CW; Frequency: 835 MHz; Communication System PAR: 0 dB

Phantom section: RF Section

Measurement Standard: DASYS (IEEE/IEC/ANSI C63.19-2007)

DASY Configuration:

- Probe: H3DV6 - SN6288; ; Calibrated: 2011/5/23
- Sensor-Surface: (Fix Surface)
- Electronics: DAE4 Sn1207; Calibrated: 2011/5/19
- Phantom: HAC Test Arch with AMCC; Type: SD HAC P01 BA
- DASYS 52.8.0(692); SEMCAD X 14.6.4(4989)

Dipole H-Field measurement with H3DV6 probe/H Scan - measurement distance from the probe sensor center to CD835 Dipole = 10mm/Hearing Aid Compatibility Test (41x361x1): Measurement grid: dx=5mm, dy=5mm

Device Reference Point: 0, 0, -6.3 mm

Reference Value = 0.48 V/m; Power Drift = -0.06 dB

PMF = 1.000

H-field emissions = 0.44 A/m

Near-field category: M4 (AWF 0 dB)

PMF scaled H-field

Grid 1 M4 0.38 A/m	Grid 2 M4 0.39 A/m	Grid 3 M4 0.37 A/m
Grid 4 M4 0.42 A/m	Grid 5 M4 0.44 A/m	Grid 6 M4 0.41 A/m
Grid 7 M4 0.38 A/m	Grid 8 M4 0.41 A/m	Grid 9 M4 0.39 A/m

Cursor:

Total = 0.439 A/m

H Category: M4

Location: -1, 2, 4.7 mm

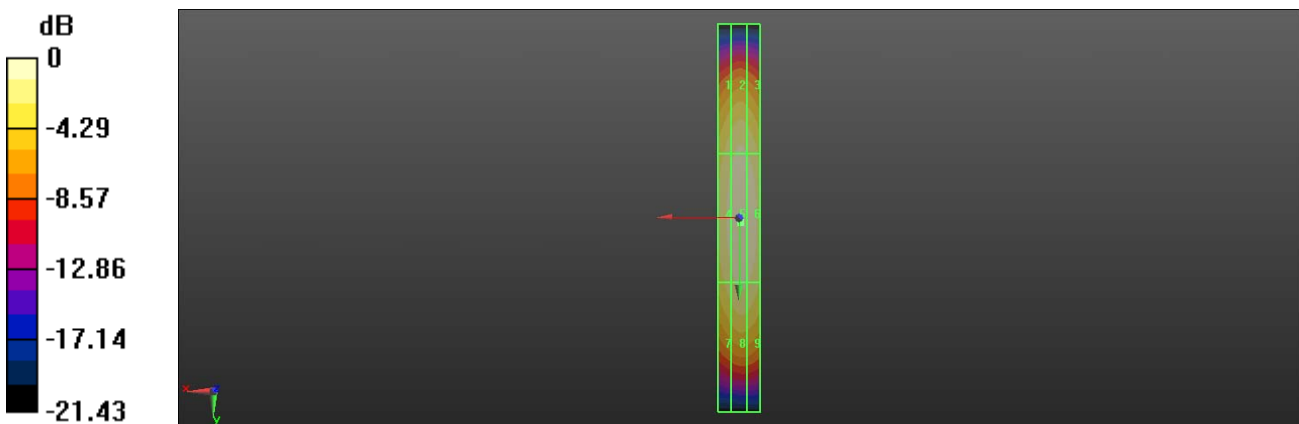

0 dB = 0.439A/m

Test Laboratory: QuieTek

Date/Time: 2012/2/16

HAC H-field Cal 1880

DUT: HAC Dipole 1880 MHz; Type: CD1880V3

Communication System: CW; Frequency: 1880 MHz; Communication System PAR: 0 dB

Phantom section: RF Section

Measurement Standard: DASYS (IEEE/IEC/ANSI C63.19-2007)

DASY Configuration:

- Probe: H3DV6 - SN6288; ; Calibrated: 2011/5/23
- Sensor-Surface: (Fix Surface)
- Electronics: DAE4 Sn1207; Calibrated: 2011/5/19
- Phantom: HAC Test Arch with AMCC; Type: SD HAC P01 BA
- DASYS 52.8.0(692); SEMCAD X 14.6.4(4989)

Dipole H-Field measurement with H3DV6 probe/H Scan - measurement distance from the probe sensor center to CD1880 Dipole = 10mm/Hearing Aid Compatibility Test (41x181x1): Measurement grid: dx=5mm, dy=5mm

Device Reference Point: 0, 0, -6.3 mm

Reference Value = 0.47 V/m; Power Drift = 0.01 dB

PMF = 1.000

H-field emissions = 0.44 A/m

Near-field category: M2 (AWF 0 dB)

PMF scaled H-field

Grid 1 M2 0.37 A/m	Grid 2 M2 0.41 A/m	Grid 3 M2 0.39 A/m
Grid 4 M2 0.40 A/m	Grid 5 M2 0.44 A/m	Grid 6 M2 0.42 A/m
Grid 7 M2 0.37 A/m	Grid 8 M2 0.40 A/m	Grid 9 M2 0.38 A/m

Cursor:

Total = 0.442 A/m

H Category: M2

Location: -1.5, 0.5, 4.7 mm

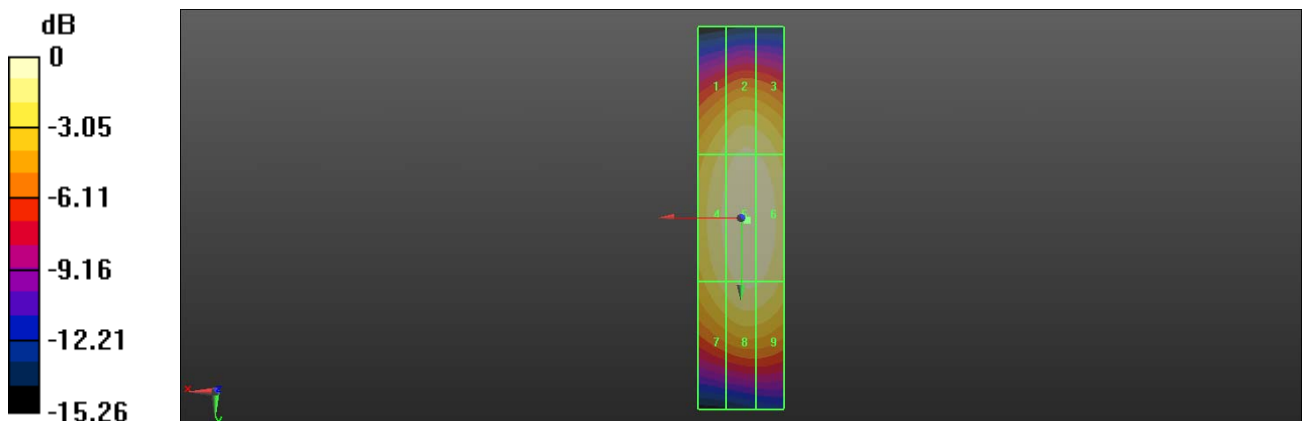

0 dB = 0.442A/m

Appendix B. HAC RF Emission Measurement Data

Test Laboratory: QuieTek

Date/Time: 2012/2/16

HAC E-field 835 CH 128

DUT: Mobile Phone; Type: K100

Communication System: FCC GSM_850MHz; Frequency: 824.2 MHz; Communication System PAR: 9.191 dB

Phantom section: RF Section

Measurement Standard: DASY5 (IEEE/IEC/ANSI C63.19-2007)

DASY Configuration:

- Probe: ER3DV6 - SN2466; ConvF(1, 1, 1); Calibrated: 2011/5/18
- Sensor-Surface: (Fix Surface)
- Electronics: DAE4 Sn1207; Calibrated: 2011/5/19
- Phantom: HAC Test Arch with AMCC; Type: SD HAC P01 BA
- DASY52 52.8.0(692); SEMCAD X 14.6.4(4989)

Device E-Field measurement with ER probe/E Scan - ER3D - 2007: 15 mm from Probe Center to the Device/Hearing Aid Compatibility Test (101x101x1):

Measurement grid: dx=5mm, dy=5mm

Device Reference Point: 0, 0, -6.3 mm

Reference Value = 35.93 V/m; Power Drift = 0.12 dB

PMF = 2.700

E-field emissions = 96.96 V/m

Near-field category: M4 (AWF -5 dB)

PMF scaled E-field

Grid 1 M4 95.03 V/m	Grid 2 M4 101.7 V/m	Grid 3 M4 101.2 V/m
Grid 4 M4 68.07 V/m	Grid 5 M4 96.96 V/m	Grid 6 M4 97.99 V/m
Grid 7 M4 61.26 V/m	Grid 8 M4 87.77 V/m	Grid 9 M4 88.97 V/m

Cursor:

Total = 101.7 V/m

E Category: M4

Location: -5, -20.5, 8.7 mm

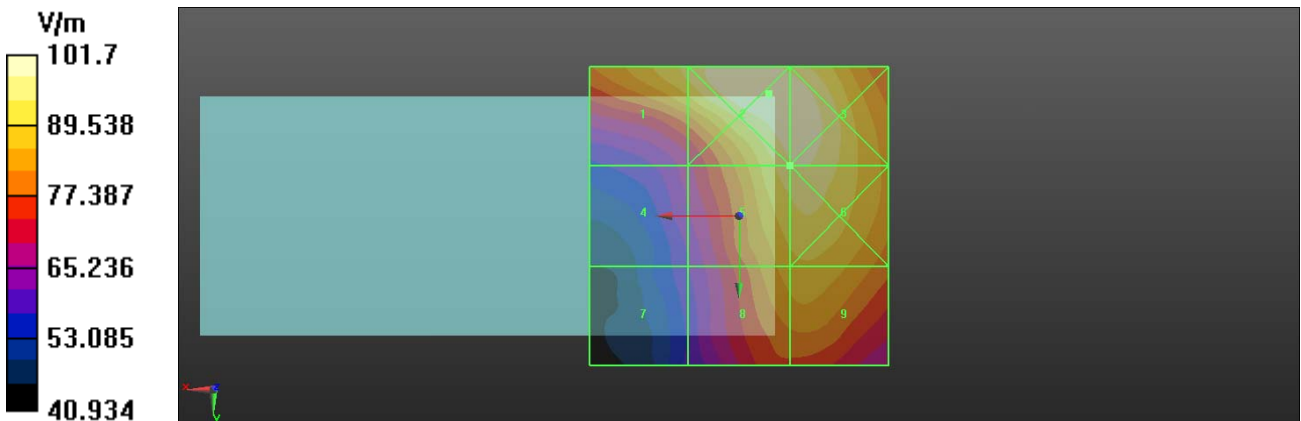

Test Laboratory: QuieTek

Date/Time: 2012/2/16

HAC E-field 835 CH 189

DUT: Mobile Phone; Type: K100

Communication System: FCC GSM_850MHz; Frequency: 836.4 MHz; Communication System PAR: 9.191 dB

Phantom section: RF Section

Measurement Standard: DASYS (IEEE/IEC/ANSI C63.19-2007)

DASY Configuration:

- Probe: ER3DV6 - SN2466; ConvF(1, 1, 1); Calibrated: 2011/5/18
- Sensor-Surface: (Fix Surface)
- Electronics: DAE4 Sn1207; Calibrated: 2011/5/19
- Phantom: HAC Test Arch with AMCC; Type: SD HAC P01 BA
- DASYS 52.8.0(692); SEMCAD X 14.6.4(4989)

Device E-Field measurement with ER probe/E Scan - ER3D - 2007: 15 mm from Probe Center to the Device/Hearing Aid Compatibility Test (101x101x1):

Measurement grid: dx=5mm, dy=5mm

Device Reference Point: 0, 0, -6.3 mm

Reference Value = 28.95 V/m; Power Drift = -0.05 dB

PMF = 2.700

E-field emissions = 78.73 V/m

Near-field category: M4 (AWF -5 dB)

PMF scaled E-field

Grid 1 M4 79.84 V/m	Grid 2 M4 83.91 V/m	Grid 3 M4 82.59 V/m
Grid 4 M4 56.50 V/m	Grid 5 M4 78.06 V/m	Grid 6 M4 78.73 V/m
Grid 7 M4 48.68 V/m	Grid 8 M4 68.41 V/m	Grid 9 M4 69.31 V/m

Cursor:

Total = 83.910 V/m

E Category: M4

Location: -2.5, -22.5, 8.7 mm

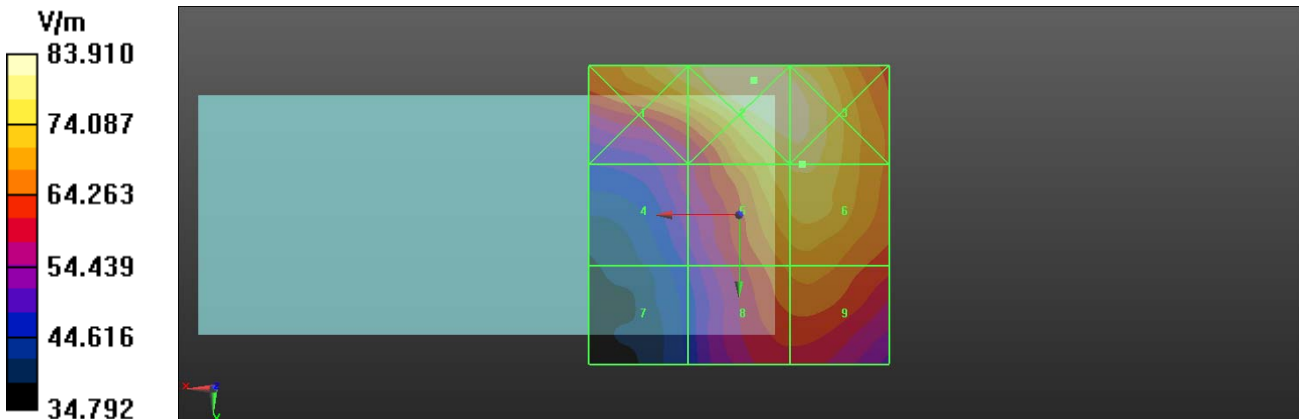

Test Laboratory: QuieTek

Date/Time: 2012/2/16

HAC E-field 835 CH 251

DUT: Mobile Phone; Type: K100

Communication System: FCC GSM_850MHz; Frequency: 836.4 MHz; Communication System PAR: 9.191 dB

Phantom section: RF Section

Measurement Standard: DASYS (IEEE/IEC/ANSI C63.19-2007)

DASY Configuration:

- Probe: ER3DV6 - SN2466; ConvF(1, 1, 1); Calibrated: 2011/5/18
- Sensor-Surface: (Fix Surface)
- Electronics: DAE4 Sn1207; Calibrated: 2011/5/19
- Phantom: HAC Test Arch with AMCC; Type: SD HAC P01 BA
- DASYS 52.8.0(692); SEMCAD X 14.6.4(4989)

Device E-Field measurement with ER probe/E Scan - ER3D - 2007: 15 mm from Probe Center to the Device/Hearing Aid Compatibility Test (101x101x1): Measurement grid: dx=5mm, dy=5mm

Device Reference Point: 0, 0, -6.3 mm

Reference Value = 25.16 V/m; Power Drift = -0.13 dB

PMF = 2.700

E-field emissions = 65.09 V/m

Near-field category: M4 (AWF -5 dB)

PMF scaled E-field

Grid 1 M4 66.99 V/m	Grid 2 M4 71.00 V/m	Grid 3 M4 69.20 V/m
Grid 4 M4 48.20 V/m	Grid 5 M4 64.42 V/m	Grid 6 M4 65.09 V/m
Grid 7 M4 41.28 V/m	Grid 8 M4 57.17 V/m	Grid 9 M4 58.09 V/m

Cursor:

Total = 71.000 V/m

E Category: M4

Location: -1, -23, 8.7 mm

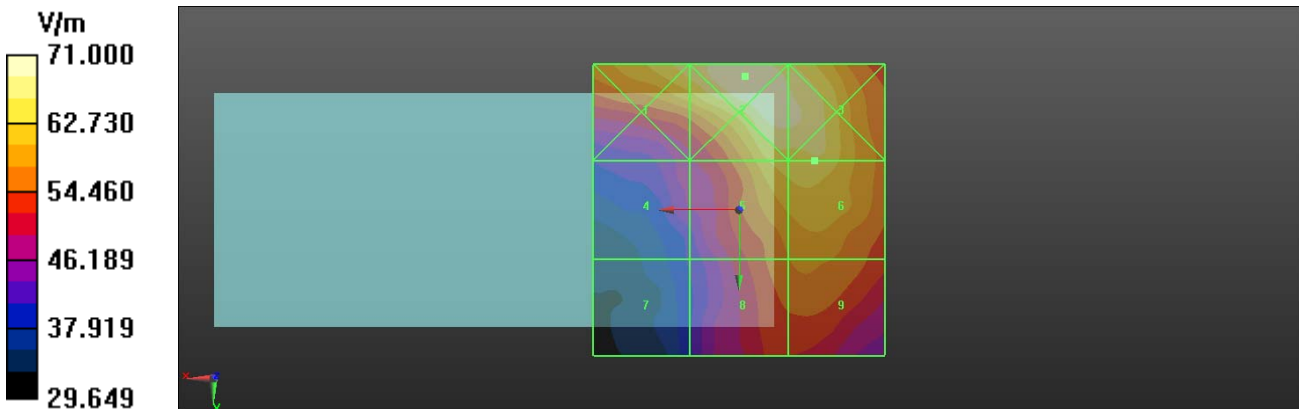

Test Laboratory: QuieTek
HAC E-field 1900 CH 512

Date/Time: 2012/2/16

DUT: Mobile Phone; Type: K100

Communication System: FCC PCS_1900MHz; Frequency: 1850.2 MHz; Communication System PAR: 9.191 dB

Phantom section: RF Section

Measurement Standard: DASYS (IEEE/IEC/ANSI C63.19-2007)

DASY Configuration:

- Probe: ER3DV6 - SN2466; ConvF(1, 1, 1); Calibrated: 2011/5/18
- Sensor-Surface: (Fix Surface)
- Electronics: DAE4 Sn1207; Calibrated: 2011/5/19
- Phantom: HAC Test Arch with AMCC; Type: SD HAC P01 BA
- DASYS 52.8.0(692); SEMCAD X 14.6.4(4989)

Device E-Field measurement with ER probe/E Scan - ER3D - 2007: 15 mm from Probe Center to the Device/Hearing Aid Compatibility Test (101x101x1):

Measurement grid: dx=5mm, dy=5mm

Device Reference Point: 0, 0, -6.3 mm

Reference Value = 24.43 V/m; Power Drift = -0.18 dB

PMF = 2.630

E-field emissions = 56.12 V/m

Near-field category: M3 (AWF -5 dB)

PMF scaled E-field

Grid 1 M3 58.76 V/m	Grid 2 M3 56.09 V/m	Grid 3 M4 46.79 V/m
Grid 4 M3 58.56 V/m	Grid 5 M3 56.12 V/m	Grid 6 M3 48.95 V/m
Grid 7 M3 53.03 V/m	Grid 8 M3 52.87 V/m	Grid 9 M3 48.97 V/m

Cursor:

Total = 58.762 V/m

E Category: M3

Location: 19.5, -10.5, 8.7 mm

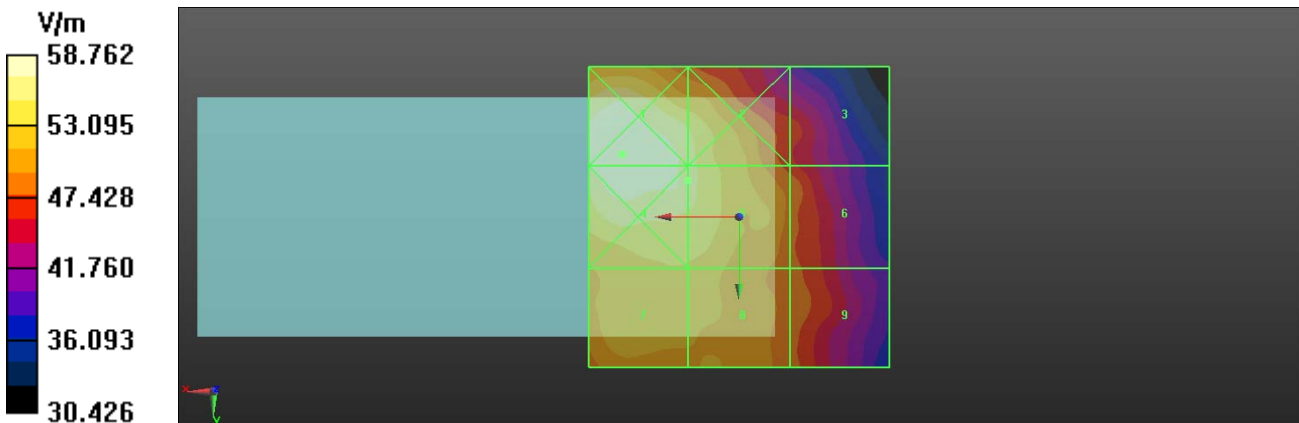

Test Laboratory: QuieTek
HAC E-field 1900 CH 661

Date/Time: 2012/2/16

DUT: Mobile Phone; Type: K100

Communication System: FCC PCS_1900MHz; Frequency: 1880 MHz; Communication System PAR: 9.191 dB

Phantom section: RF Section

Measurement Standard: DASYS (IEEE/IEC/ANSI C63.19-2007)

DASY Configuration:

- Probe: ER3DV6 - SN2466; ConvF(1, 1, 1); Calibrated: 2011/5/18
- Sensor-Surface: (Fix Surface)
- Electronics: DAE4 Sn1207; Calibrated: 2011/5/19
- Phantom: HAC Test Arch with AMCC; Type: SD HAC P01 BA
- DASYS 52.8.0(692); SEMCAD X 14.6.4(4989)

Device E-Field measurement with ER probe/E Scan - ER3D - 2007: 15 mm from Probe Center to the Device/Hearing Aid Compatibility Test (101x101x1):

Measurement grid: dx=5mm, dy=5mm

Device Reference Point: 0, 0, -6.3 mm

Reference Value = 29.18 V/m; Power Drift = -0.13 dB

PMF = 2.630

E-field emissions = 68.09 V/m

Near-field category: M3 (AWF -5 dB)

PMF scaled E-field

Grid 1 M3 69.88 V/m	Grid 2 M3 68.06 V/m	Grid 3 M3 59.29 V/m
Grid 4 M3 70.33 V/m	Grid 5 M3 68.09 V/m	Grid 6 M3 60.66 V/m
Grid 7 M3 63.71 V/m	Grid 8 M3 62.44 V/m	Grid 9 M3 57.23 V/m

Cursor:

Total = 70.335 V/m

E Category: M3

Location: 19.5, -6, 8.7 mm

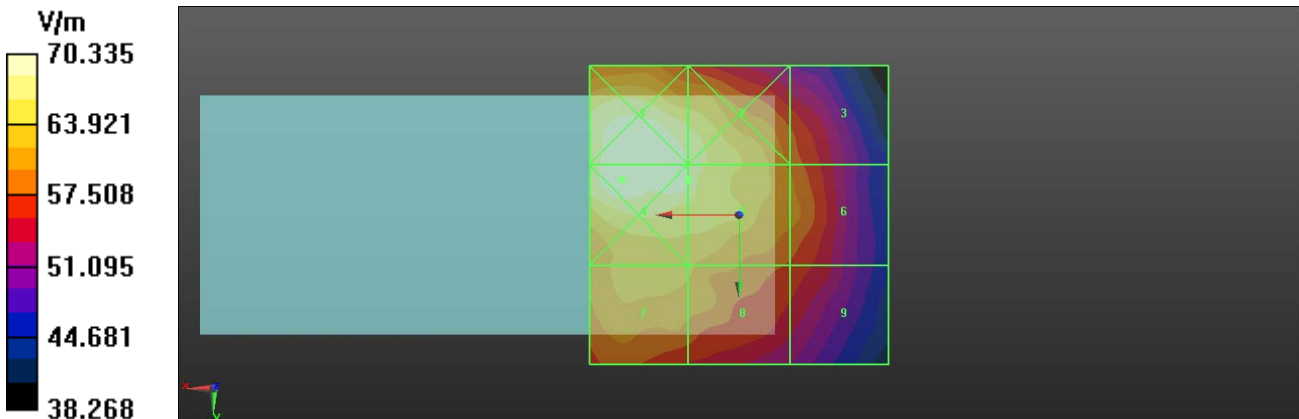

Test Laboratory: QuieTek

Date/Time: 2012/2/16

HAC E-field 1900 CH 810

DUT: Mobile Phone; Type: K100

Communication System: FCC PCS_1900MHz; Frequency: 1909.8 MHz; Communication System PAR: 9.191 dB

Phantom section: RF Section

Measurement Standard: DASY5 (IEEE/IEC/ANSI C63.19-2007)

DASY Configuration:

- Probe: ER3DV6 - SN2466; ConvF(1, 1, 1); Calibrated: 2010/5/20
- Sensor-Surface: (Fix Surface)
- Electronics: DAE4 Sn1207; Calibrated: 2011/5/19
- Phantom: HAC Test Arch with AMCC; Type: SD HAC P01 BA
- DASY52 52.8.0(692); SEMCAD X 14.6.4(4989)

Device E-Field measurement with ER probe/E Scan - ER3D - 2007: 15 mm from Probe Center to the Device/Hearing Aid Compatibility Test (101x101x1):

Measurement grid: dx=5mm, dy=5mm

Device Reference Point: 0, 0, -6.3 mm

Reference Value = 35.53 V/m; Power Drift = 0.10 dB

PMF = 2.630

E-field emissions = 80.15 V/m

Near-field category: M3 (AWF -5 dB)

PMF scaled E-field

Grid 1 M3 81.72 V/m	Grid 2 M3 80.17 V/m	Grid 3 M3 69.56 V/m
Grid 4 M3 81.65 V/m	Grid 5 M3 80.15 V/m	Grid 6 M3 69.72 V/m
Grid 7 M3 71.44 V/m	Grid 8 M3 69.20 V/m	Grid 9 M3 61.29 V/m

Cursor:

Total = 81.715 V/m

E Category: M3

Location: 15, -9.5, 8.7 mm

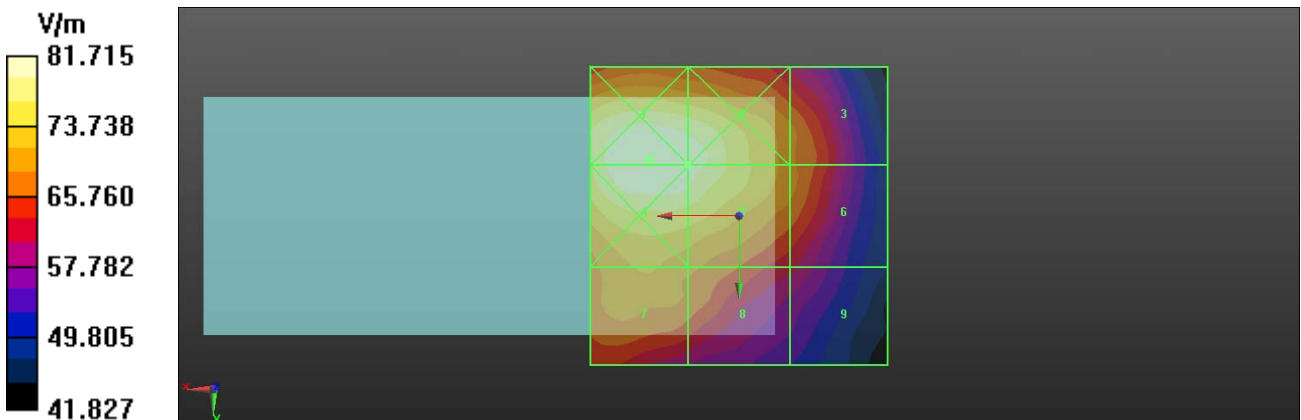

Test Laboratory: QuieTek

Date/Time: 2012/2/16

HAC H-field 835 CH 128

DUT: Mobile Phone; Type: K100

Communication System: FCC GSM_850MHz; Frequency: 824.2 MHz; Communication System PAR: 9.191 dB

Phantom section: RF Section

Measurement Standard: DASYS (IEEE/IEC/ANSI C63.19-2007)

DASY Configuration:

- Probe: H3DV6 - SN6288; ; Calibrated: 2011/5/23
- Sensor-Surface: (Fix Surface)
- Electronics: DAE4 Sn1207; Calibrated: 2011/5/19
- Phantom: HAC Test Arch with AMCC; Type: SD HAC P01 BA
- DASYS 52.8.0(692); SEMCAD X 14.6.4(4989)

Device H-Field measurement with H3DV6 probe/H Scan - H3DV6 - 2007: 15 mm from Probe Center to the Device/Hearing Aid Compatibility Test (101x101x1):

Measurement grid: dx=5mm, dy=5mm

Device Reference Point: 0, 0, -6.3 mm

Reference Value = 0.10 V/m; Power Drift = -0.05 dB

PMF = 2.710

H-field emissions = 0.33 A/m

Near-field category: M4 (AWF -5 dB)

PMF scaled H-field

Grid 1 M4 0.32 A/m	Grid 2 M4 0.26 A/m	Grid 3 M4 0.20 A/m
Grid 4 M4 0.33 A/m	Grid 5 M4 0.28 A/m	Grid 6 M4 0.23 A/m
Grid 7 M4 0.33 A/m	Grid 8 M4 0.29 A/m	Grid 9 M4 0.23 A/m

Cursor:

Total = 0.333 A/m

H Category: M4

Location: 25, 10.5, 8.7 mm

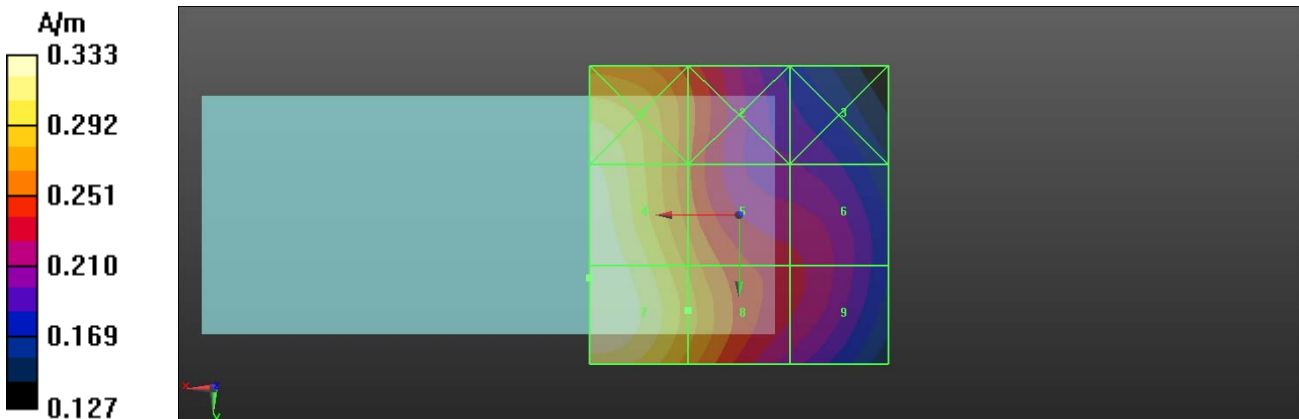

Test Laboratory: QuieTek

Date/Time: 2012/2/16

HAC H-field 835 CH 189

DUT: Mobile Phone; Type: K100

Communication System: FCC GSM_850MHz; Frequency: 836.4 MHz; Communication System PAR: 9.191 dB

Phantom section: RF Section

Measurement Standard: DASYS (IEEE/IEC/ANSI C63.19-2007)

DASY Configuration:

- Probe: H3DV6 - SN6288; ; Calibrated: 2011/5/23
- Sensor-Surface: (Fix Surface)
- Electronics: DAE4 Sn1207; Calibrated: 2011/5/19
- Phantom: HAC Test Arch with AMCC; Type: SD HAC P01 BA
- DASYS 52.8.0(692); SEMCAD X 14.6.4(4989)

Device H-Field measurement with H3DV6 probe/H Scan - H3DV6 - 2007: 15 mm from Probe Center to the Device/Hearing Aid Compatibility Test (101x101x1):

Measurement grid: dx=5mm, dy=5mm

Device Reference Point: 0, 0, -6.3 mm

Reference Value = 0.09 V/m; Power Drift = -0.14 dB

PMF = 2.710

H-field emissions = 0.29 A/m

Near-field category: M4 (AWF -5 dB)

PMF scaled H-field

Grid 1 M4 0.28 A/m	Grid 2 M4 0.23 A/m	Grid 3 M4 0.18 A/m
Grid 4 M4 0.29 A/m	Grid 5 M4 0.24 A/m	Grid 6 M4 0.21 A/m
Grid 7 M4 0.29 A/m	Grid 8 M4 0.25 A/m	Grid 9 M4 0.21 A/m

Cursor:

Total = 0.289 A/m

H Category: M4

Location: 25, 14, 8.7 mm

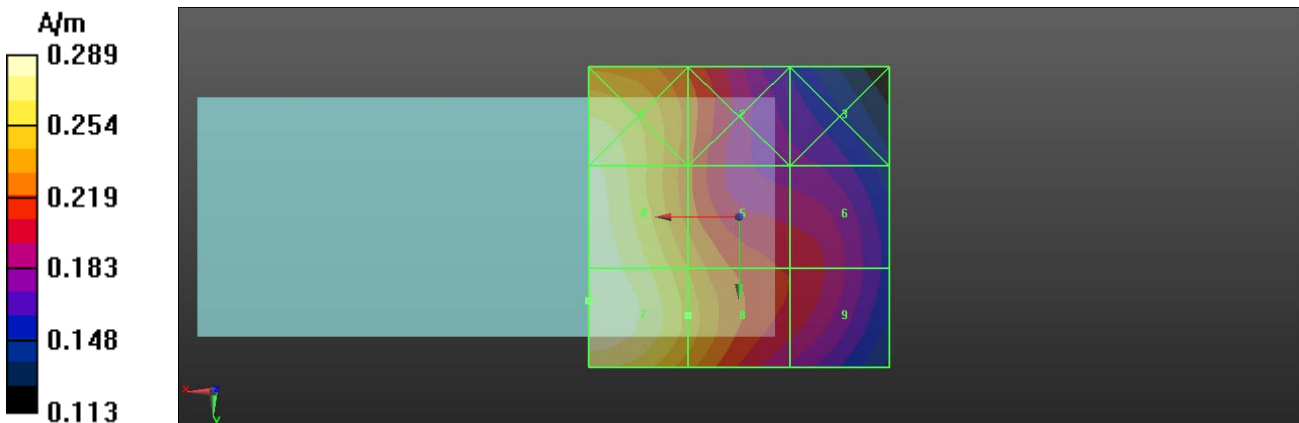

Test Laboratory: QuieTek

Date/Time: 2012/2/16

HAC H-field 835 CH 251

DUT: Mobile Phone; Type: K100

Communication System: FCC GSM_850MHz; Frequency: 848.8 MHz; Communication System PAR: 9.191 dB

Phantom section: RF Section

Measurement Standard: DASYS (IEEE/IEC/ANSI C63.19-2007)

DASY Configuration:

- Probe: H3DV6 - SN6288; ; Calibrated: 2011/5/23
- Sensor-Surface: (Fix Surface)
- Electronics: DAE4 Sn1207; Calibrated: 2011/5/19
- Phantom: HAC Test Arch with AMCC; Type: SD HAC P01 BA
- DASYS 52.8.0(692); SEMCAD X 14.6.4(4989)

Device H-Field measurement with H3DV6 probe/H Scan - H3DV6 - 2007: 15 mm from Probe Center to the Device/Hearing Aid Compatibility Test (101x101x1): Measurement grid: dx=5mm, dy=5mm

Device Reference Point: 0, 0, -6.3 mm

Reference Value = 0.07 V/m; Power Drift = -0.06 dB

PMF = 2.710

H-field emissions = 0.24 A/m

Near-field category: M4 (AWF -5 dB)

PMF scaled H-field

Grid 1 M4 0.23 A/m	Grid 2 M4 0.19 A/m	Grid 3 M4 0.15 A/m
Grid 4 M4 0.24 A/m	Grid 5 M4 0.20 A/m	Grid 6 M4 0.17 A/m
Grid 7 M4 0.24 A/m	Grid 8 M4 0.21 A/m	Grid 9 M4 0.17 A/m

Cursor:

Total = 0.237 A/m

H Category: M4

Location: 25, 14, 8.7 mm

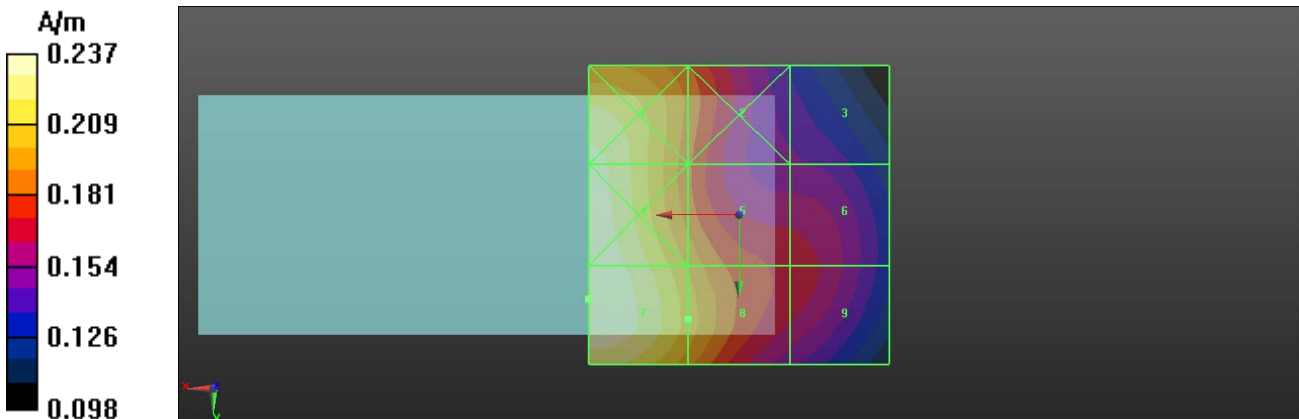

Test Laboratory: QuieTek
HAC H-field 1900 CH 512

Date/Time: 2012/2/16

DUT: Mobile Phone; Type: K100

Communication System: FCC PCS_1900MHz; Frequency: 1850.2 MHz; Communication System PAR: 9.191 dB

Phantom section: RF Section

Measurement Standard: DASYS (IEEE/IEC/ANSI C63.19-2007)

DASY Configuration:

- Probe: H3DV6 - SN6288; ; Calibrated: 2011/5/23
- Sensor-Surface: (Fix Surface)
- Electronics: DAE4 Sn1207; Calibrated: 2011/5/19
- Phantom: HAC Test Arch with AMCC; Type: SD HAC P01 BA
- DASYS 52.8.0(692); SEMCAD X 14.6.4(4989)

Device H-Field measurement with H3DV6 probe/H Scan - H3DV6 - 2007: 15 mm from Probe Center to the Device/Hearing Aid Compatibility Test (101x101x1): Measurement grid: dx=5mm, dy=5mm

Device Reference Point: 0, 0, -6.3 mm

Reference Value = 0.06 V/m; Power Drift = 0.01 dB

PMF = 2.780

H-field emissions = 0.16 A/m

Near-field category: M3 (AWF -5 dB)

PMF scaled H-field

Grid 1 M4 0.13 A/m	Grid 2 M4 0.13 A/m	Grid 3 M4 0.12 A/m
Grid 4 M3 0.16 A/m	Grid 5 M3 0.16 A/m	Grid 6 M4 0.14 A/m
Grid 7 M3 0.16 A/m	Grid 8 M3 0.16 A/m	Grid 9 M4 0.14 A/m

Cursor:

Total = 0.156 A/m

H Category: M3

Location: 8.5, 10, 8.7 mm

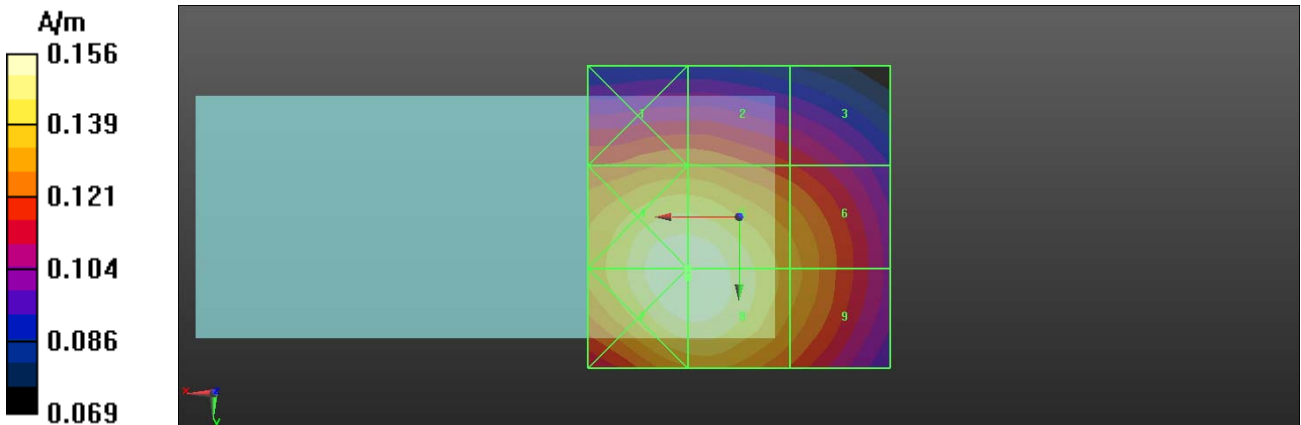

Test Laboratory: QuieTek

Date/Time: 2012/2/16

HAC H-field 1900 CH 661

DUT: Mobile Phone; Type: K100

Communication System: FCC PCS_1900MHz; Frequency: 1880 MHz; Communication System PAR: 9.191 dB

Phantom section: RF Section

Measurement Standard: DASYS (IEEE/IEC/ANSI C63.19-2007)

DASY Configuration:

- Probe: H3DV6 - SN6288; ; Calibrated: 2011/5/23
- Sensor-Surface: (Fix Surface)
- Electronics: DAE4 Sn1207; Calibrated: 2011/5/19
- Phantom: HAC Test Arch with AMCC; Type: SD HAC P01 BA
- DASYS 52.8.0(692); SEMCAD X 14.6.4(4989)

Device H-Field measurement with H3DV6 probe/H Scan - H3DV6 - 2007: 15 mm from Probe Center to the Device/Hearing Aid Compatibility Test (101x101x1): Measurement grid: dx=5mm, dy=5mm

Device Reference Point: 0, 0, -6.3 mm

Reference Value = 0.08 V/m; Power Drift = 0.04 dB

PMF = 2.780

H-field emissions = 0.21 A/m

Near-field category: M3 (AWF -5 dB)

PMF scaled H-field

Grid 1 M3 0.18 A/m	Grid 2 M3 0.18 A/m	Grid 3 M3 0.16 A/m
Grid 4 M3 0.21 A/m	Grid 5 M3 0.21 A/m	Grid 6 M3 0.19 A/m
Grid 7 M3 0.21 A/m	Grid 8 M3 0.21 A/m	Grid 9 M3 0.19 A/m

Cursor:

Total = 0.212 A/m

H Category: M3

Location: 7, 9.5, 8.7 mm

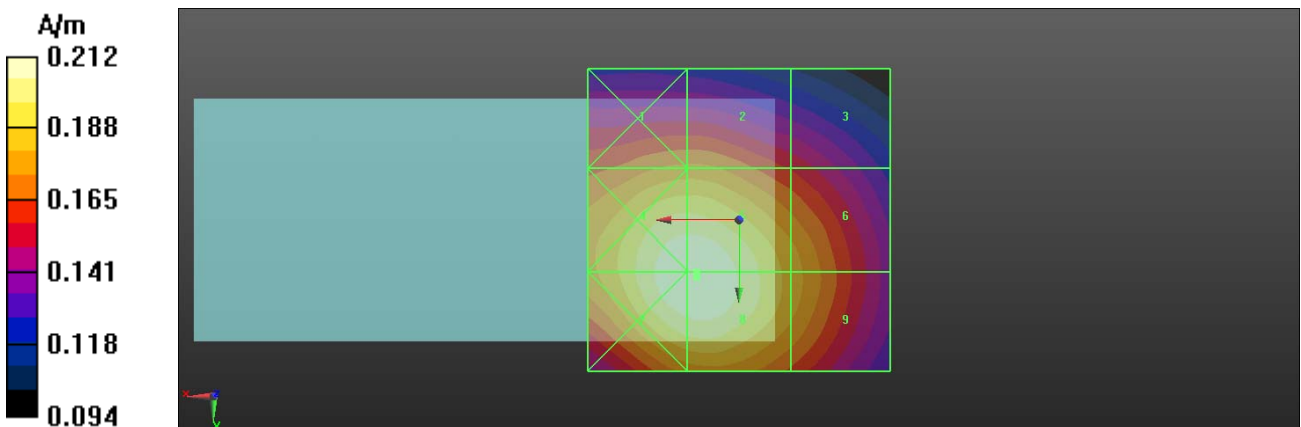

Test Laboratory: QuieTek
HAC H-field 1900 CH 885

Date/Time: 2012/2/16

DUT: Mobile Phone; Type: K100

Communication System: FCC PCS_1900MHz; Frequency: 1909.8 MHz; Communication System PAR: 9.191 dB

Phantom section: RF Section

Measurement Standard: DASYS (IEEE/IEC/ANSI C63.19-2007)

DASY Configuration:

- Probe: H3DV6 - SN6288; ; Calibrated: 2011/5/23
- Sensor-Surface: (Fix Surface)
- Electronics: DAE4 Sn1207; Calibrated: 2011/5/19
- Phantom: HAC Test Arch with AMCC; Type: SD HAC P01 BA
- DASYS 52.8.0(692); SEMCAD X 14.6.4(4989)

Device H-Field measurement with H3DV6 probe/H Scan - H3DV6 - 2007: 15 mm from Probe Center to the Device/Hearing Aid Compatibility Test (101x101x1): Measurement grid: dx=5mm, dy=5mm

Device Reference Point: 0, 0, -6.3 mm

Reference Value = 0.10 V/m; Power Drift = -0.02 dB

PMF = 2.780

H-field emissions = 0.25 A/m

Near-field category: M3 (AWF -5 dB)

PMF scaled H-field

Grid 1 M3 0.20 A/m	Grid 2 M3 0.20 A/m	Grid 3 M3 0.18 A/m
Grid 4 M3 0.25 A/m	Grid 5 M3 0.25 A/m	Grid 6 M3 0.22 A/m
Grid 7 M3 0.25 A/m	Grid 8 M3 0.25 A/m	Grid 9 M3 0.22 A/m

Cursor:

Total = 0.247 A/m

H Category: M3

Location: 7, 10, 8.7 mm

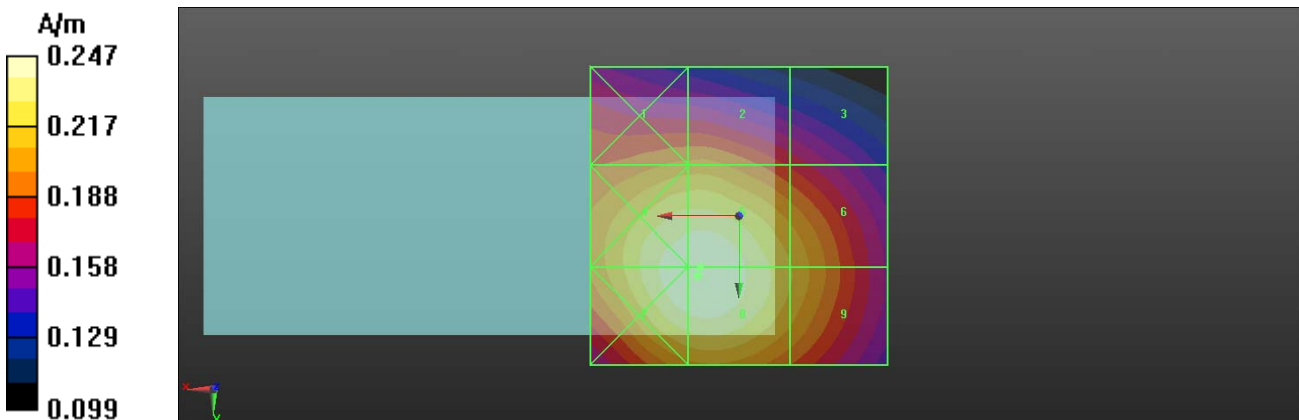

Appendix C. Test Setup Photographs & EUT Photographs
Test Setup Photographs

HAC Front View



HAC Side View



EUT Photographs



1130

**Calibration Laboratory of
Schmid & Partner
Engineering AG**
Zeughausstrasse 43, 8004 Zurich, Switzerland



S Schweizerischer Kalibrierdienst
C Service suisse d'étalonnage
S Servizio svizzero di taratura
Swiss Calibration Service

Accredited by the Swiss Accreditation Service (SAS)
The Swiss Accreditation Service is one of the signatories to the EA
Multilateral Agreement for the recognition of calibration certificates

Accreditation No.: **SCS 108**

Client **Quietek (Auden)**

Certificate No: **ER3-2466_May11**

CALIBRATION CERTIFICATE

Object: **ER3DV6 - SN:2466**

Calibration procedure(s): **QA CAL-02.v6, QA CAL-25.v3
Calibration procedure for E-field probes optimized for close near field
evaluations in air**

Calibration date: **May 18, 2011**

This calibration certificate documents the traceability to national standards, which realize the physical units of measurements (SI).
The measurements and the uncertainties with confidence probability are given on the following pages and are part of the certificate.

All calibrations have been conducted in the closed laboratory facility: environment temperature (22 ± 3)°C and humidity < 70%.

Calibration Equipment used (M&TE critical for calibration)

Primary Standards	ID	Cal Date (Certificate No.)	Scheduled Calibration
Power meter E4419B	GB41293874	31-Mar-11 (No. 217-01372)	Apr-12
Power sensor E4412A	MY41498087	31-Mar-11 (No. 217-01372)	Apr-12
Reference 3 dB Attenuator	SN: S5054 (3c)	29-Mar-11 (No. 217-01369)	Apr-12
Reference 20 dB Attenuator	SN: S5086 (20b)	29-Mar-11 (No. 217-01367)	Apr-12
Reference 30 dB Attenuator	SN: S5129 (30b)	29-Mar-11 (No. 217-01370)	Apr-12
Reference Probe ER3DV6	SN: 2328	4-Oct-10 (No. ER3-2328_Oct10)	Oct-11
DAE4	SN: 789	6-Apr-11 (No. DAE4-789_Apr11)	Apr-12
Secondary Standards	ID	Check Date (in house)	Scheduled Check
RF generator HP 8648C	US3642U01700	4-Aug-99 (in house check Oct-09)	In house check: Oct-11
Network Analyzer HP 8753E	US37390585	18-Oct-01 (in house check Oct-10)	In house check: Oct-11

Calibrated by:	Name Claudio Leubler	Function Laboratory Technician	Signature
Approved by:	Name Katja Pokovic	Function Technical Manager	Signature

Issued: May 18, 2011

This calibration certificate shall not be reproduced except in full without written approval of the laboratory.



Accredited by the Swiss Accreditation Service (SAS)

Accreditation No.: **SCS 108**

The Swiss Accreditation Service is one of the signatories to the EA
Multilateral Agreement for the recognition of calibration certificates

Glossary:

NORM _{x,y,z}	sensitivity in free space
DCP	diode compression point
CF	crest factor (1/duty_cycle) of the RF signal
A, B, C	modulation dependent linearization parameters
Polarization φ	φ rotation around probe axis
Polarization ϑ	ϑ rotation around an axis that is in the plane normal to probe axis (at measurement center), i.e., $\vartheta = 0$ is normal to probe axis
Connector Angle	information used in DASY system to align probe sensor X to the robot coordinate system

Calibration is Performed According to the Following Standards:

- IEEE Std 1309-2005, "IEEE Standard for calibration of electromagnetic field sensors and probes, excluding antennas, from 9 kHz to 40 GHz", December 2005.

Methods Applied and Interpretation of Parameters:

- NORM_{x,y,z}*: Assessed for E-field polarization $\vartheta = 0$ for XY sensors and $\vartheta = 90$ for Z sensor ($f \leq 900$ MHz in TEM-cell; $f > 1800$ MHz: R22 waveguide).
- NORM(f)_{x,y,z}* = *NORM_{x,y,z}* * *frequency_response* (see Frequency Response Chart).
- DCP_{x,y,z}*: DCP are numerical linearization parameters assessed based on the data of power sweep with CW signal (no uncertainty required). DCP does not depend on frequency nor media.
- A_{x,y,z}; B_{x,y,z}; C_{x,y,z}; VR_{x,y,z}*: A, B, C are numerical linearization parameters assessed based on the data of power sweep for specific modulation signal. The parameters do not depend on frequency nor media. VR is the maximum calibration range expressed in RMS voltage across the diode.
- Spherical isotropy (3D deviation from isotropy)*: in a locally homogeneous field realized using an open waveguide setup.
- Sensor Offset*: The sensor offset corresponds to the offset of virtual measurement center from the probe tip (on probe axis). No tolerance required.
- Connector Angle*: The angle is assessed using the information gained by determining the *NORM_x* (no uncertainty required).

Probe ER3DV6

SN:2466

Manufactured: March 31, 2009

Calibrated: May 18, 2011

Calibrated for DASY/EASY Systems

(Note: non-compatible with DASY2 system!)

DASY/EASY - Parameters of Probe: ER3DV6 - SN:2466

Basic Calibration Parameters

	Sensor X	Sensor Y	Sensor Z	Unc (k=2)
Norm ($\mu\text{V}/(\text{V}/\text{m})^2$)	1.77	1.68	1.61	$\pm 10.1 \%$
DCP (mV) ^B	97.9	97.8	102.2	

Modulation Calibration Parameters

UID	Communication System Name	PAR		A dB	B dB	C dB	VR mV	Unc ^E (k=2)
10000	CW	0.00	X	0.00	0.00	1.00	114.1	$\pm 3.0 \%$
			Y	0.00	0.00	1.00	119.3	
			Z	0.00	0.00	1.00	103.0	

The reported uncertainty of measurement is stated as the standard uncertainty of measurement multiplied by the coverage factor $k=2$, which for a normal distribution corresponds to a coverage probability of approximately 95%.

^B Numerical linearization parameter: uncertainty not required.

^E Uncertainty is determined using the max. deviation from linear response applying rectangular distribution and is expressed for the square of the field value.

Frequency Response of E-Field (TEM-Cell:ifi110 EXX, Waveguide: R22)

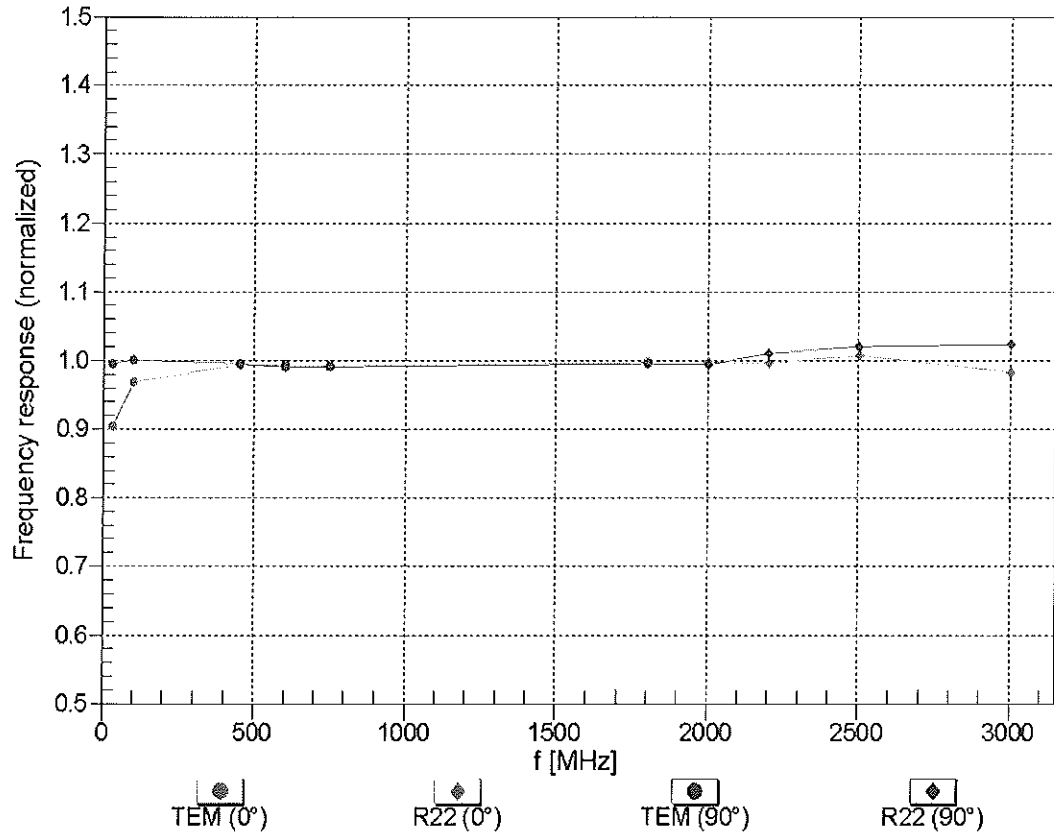

Uncertainty of Frequency Response of E-field: $\pm 6.3\%$ (k=2)

Receiving Pattern (ϕ), $\vartheta = 0^\circ$

f=600 MHz,TEM,0°

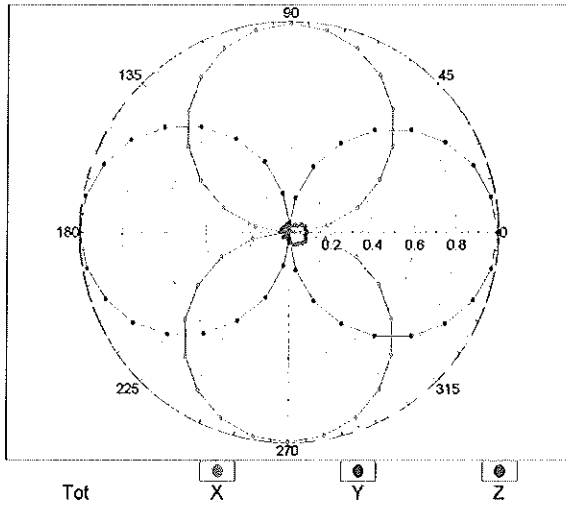

f=2500 MHz,R22,0°

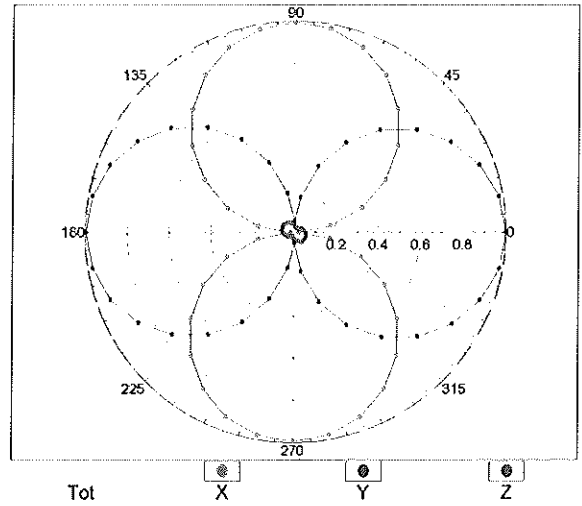

Receiving Pattern (ϕ), $\vartheta = 90^\circ$

f=600 MHz,TEM,90°

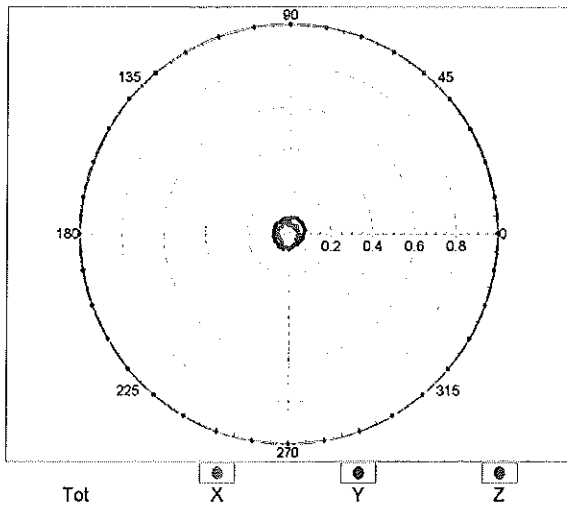

f=2500 MHz,R22,90°

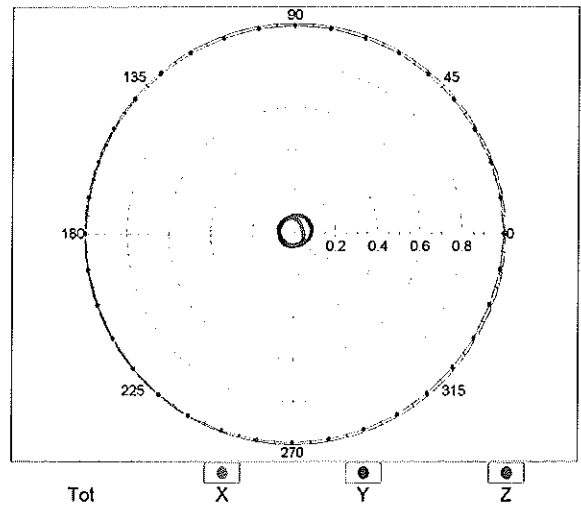

Receiving Pattern (ϕ), $\vartheta = 0^\circ$

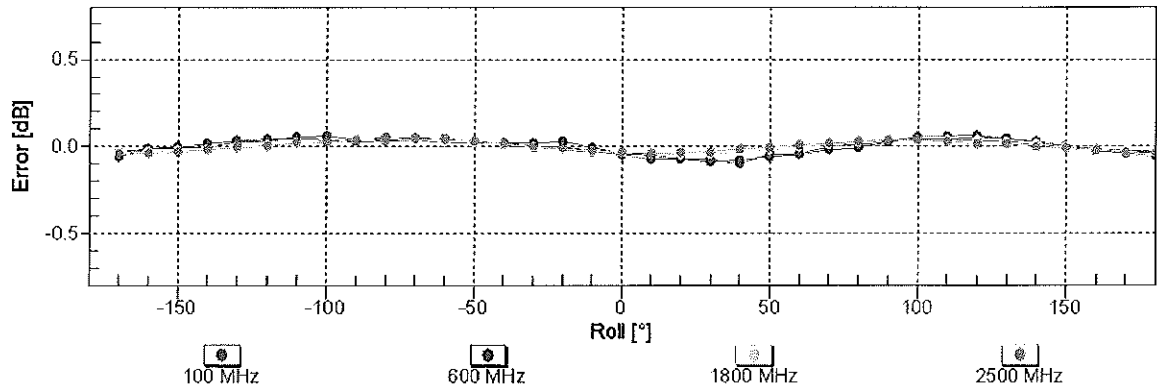

Uncertainty of Axial Isotropy Assessment: $\pm 0.5\%$ ($k=2$)

Receiving Pattern (ϕ), $\vartheta = 90^\circ$

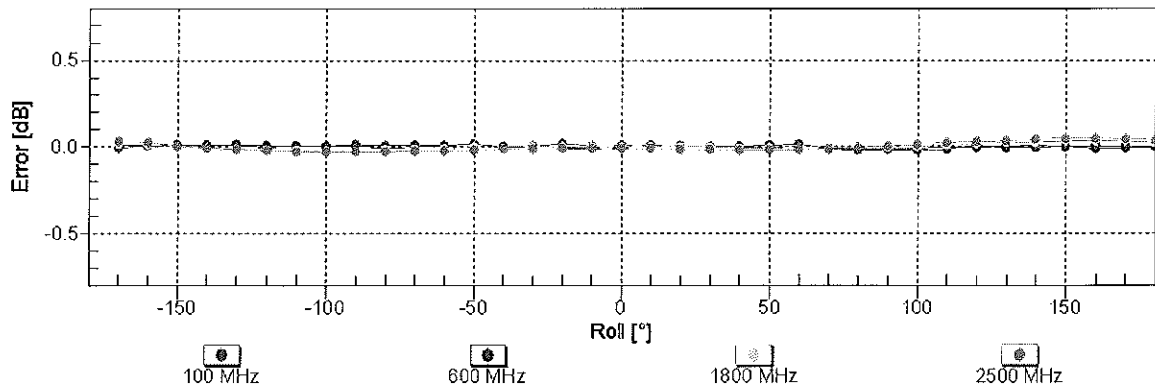

Uncertainty of Axial Isotropy Assessment: $\pm 0.5\%$ ($k=2$)

Dynamic Range f(E-field)

(TEM cell , f = 900 MHz)

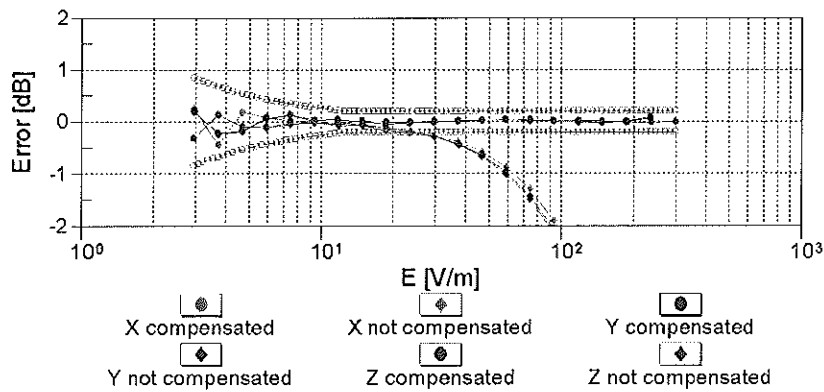
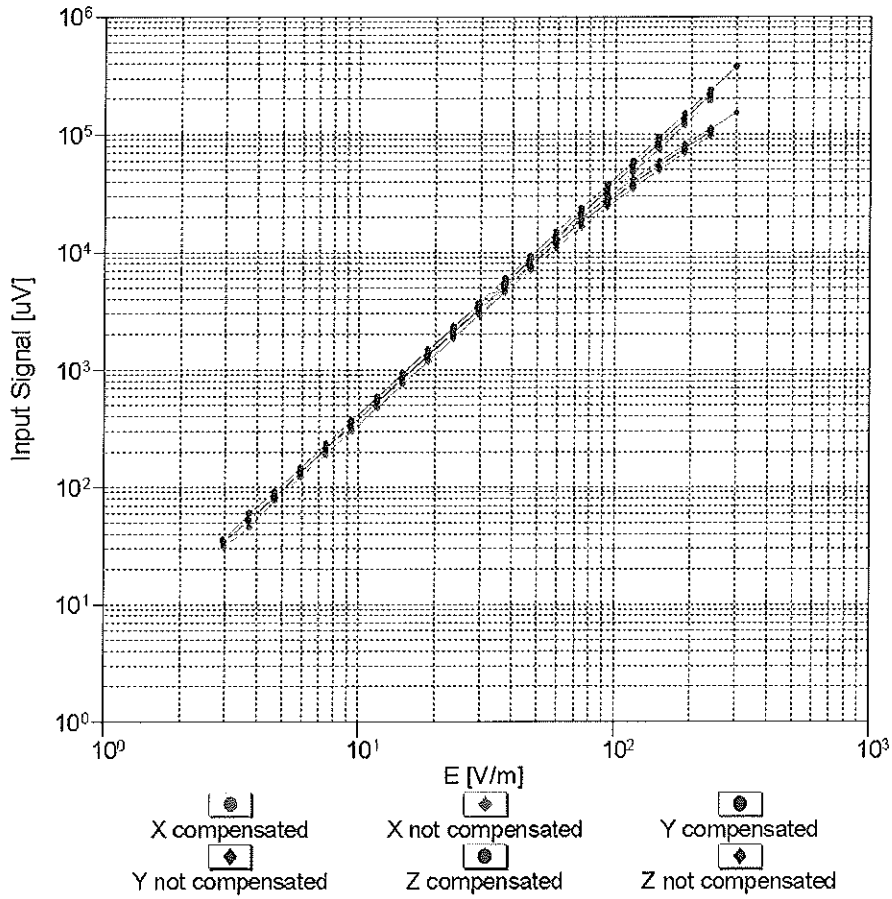

Uncertainty of Linearity Assessment: $\pm 0.6\%$ (k=2)

Deviation from Isotropy in Air

Error (ϕ , θ), $f = 900$ MHz

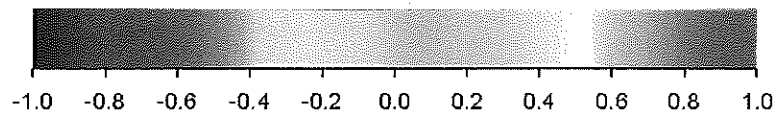
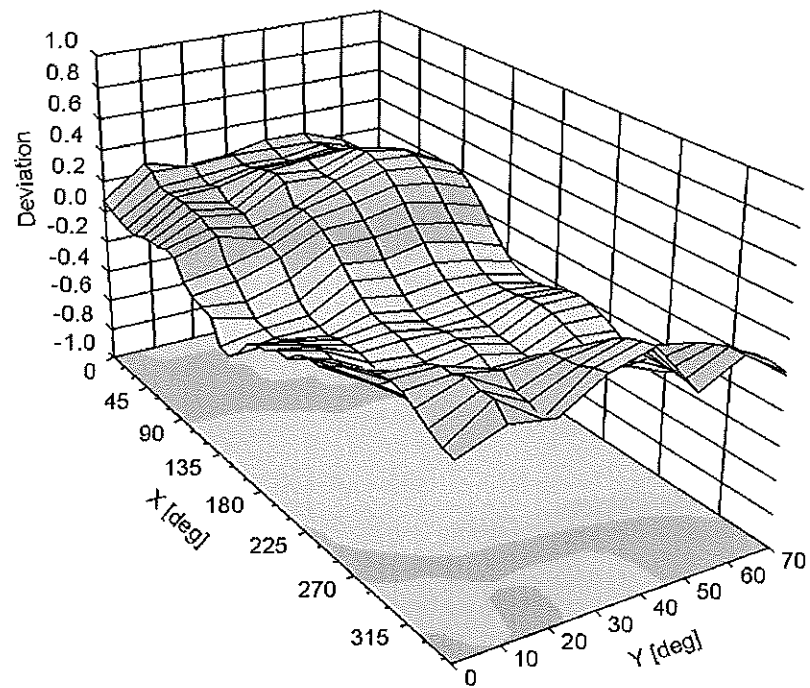

Uncertainty of Spherical Isotropy Assessment: $\pm 2.6\%$ ($k=2$)

DASY/EASY - Parameters of Probe: ER3DV6 - SN:2466

Other Probe Parameters

Sensor Arrangement	Rectangular
Connector Angle (°)	-40.2
Mechanical Surface Detection Mode	enabled
Optical Surface Detection Mode	disabled
Probe Overall Length	337 mm
Probe Body Diameter	10 mm
Tip Length	10 mm
Tip Diameter	8 mm
Probe Tip to Sensor X Calibration Point	2.5 mm
Probe Tip to Sensor Y Calibration Point	2.5 mm
Probe Tip to Sensor Z Calibration Point	2.5 mm

1154

**Calibration Laboratory of
Schmid & Partner
Engineering AG**
Zeughausstrasse 43, 8004 Zurich, Switzerland



S Schweizerischer Kalibrierdienst
C Service suisse d'étalonnage
S Servizio svizzero di taratura
S Swiss Calibration Service

Accredited by the Swiss Accreditation Service (SAS)
The Swiss Accreditation Service is one of the signatories to the EA
Multilateral Agreement for the recognition of calibration certificates

Accreditation No.: **SCS 108**

Client **Quietek (Auden)**

Certificate No: **CD835V3-1135_May11**

CALIBRATION CERTIFICATE

Object **CD835V3 - SN: 1135**

Calibration procedure(s) **QA CAL-20.v5
Calibration procedure for dipoles in air**

Calibration date: **May 17, 2011**

This calibration certificate documents the traceability to national standards, which realize the physical units of measurements (SI).
All calibrations have been conducted in the closed laboratory facility: environment temperature (22 ± 3)°C and humidity < 70%.

Calibration Equipment used (M&TE critical for calibration)

Primary Standards	ID #	Cal Date (Certificate No.)	Scheduled Calibration
Power meter EPM-442A	GB37480704	06-Oct-10 (No. 217-01266)	Oct-11
Power sensor HP 8481A	US37292783	06-Oct-10 (No. 217-01266)	Oct-11
Probe ER3DV6	SN: 2336	29-Dec-10 (No. ER3-2336_Dec10)	Dec-11
Probe H3DV6	SN: 6065	29-Dec-10 (No. H3-6065_Dec10)	Dec-11
DAE4	SN: 781	20-Apr-11 (No. DAE4-781_Apr11)	Apr-12

Secondary Standards	ID #	Check Date (in house)	Scheduled Check
Power meter Agilent 4419B	SN: GB42420191	09-Oct-09 (in house check Oct-10)	In house check: Oct-11
Power sensor HP 8482H	SN: 3318A09450	09-Oct-09 (in house check Oct-10)	In house check: Oct-11
Power sensor HP 8482A	SN: US37295597	09-Oct-09 (in house check Oct-10)	In house check: Oct-11
Network Analyzer HP 8753E	US37390585	18-Oct-01 (in house check Oct-10)	In house check: Oct-11
RF generator E4433B	MY 41000675	03-Nov-04 (in house check Oct-09)	In house check: Oct-11

Calibrated by: **Claudio Leubler** Name: Claudio Leubler Function: Laboratory Technician

Signature

Approved by: **Fin Bornholt** Name: Fin Bornholt Function: R&D Director

Issued: May 17, 2011

This calibration certificate shall not be reproduced except in full without written approval of the laboratory.



Accredited by the Swiss Accreditation Service (SAS)
The Swiss Accreditation Service is one of the signatories to the EA
Multilateral Agreement for the recognition of calibration certificates

Accreditation No.: **SCS 108**

References

- [1] ANSI-C63.19-2007
American National Standard for Methods of Measurement of Compatibility between Wireless
Communications Devices and Hearing Aids.

Methods Applied and Interpretation of Parameters:

- **Coordinate System:** y-axis is in the direction of the dipole arms. z-axis is from the basis of the antenna (mounted on the table) towards its feed point between the two dipole arms. x-axis is normal to the other axes. In coincidence with the standards [1], the measurement planes (probe sensor center) are selected to be at a distance of 10 mm above the top edge of the dipole arms.
- **Measurement Conditions:** Further details are available from the hardcopies at the end of the certificate. All figures stated in the certificate are valid at the frequency indicated. The forward power to the dipole connector is set with a calibrated power meter connected and monitored with an auxiliary power meter connected to a directional coupler. While the dipole under test is connected, the forward power is adjusted to the same level.
- **Antenna Positioning:** The dipole is mounted on a HAC Test Arch phantom using the matching dipole positioner with the arms horizontal and the feeding cable coming from the floor. The measurements are performed in a shielded room with absorbers around the setup to reduce the reflections. It is verified before the mounting of the dipole under the Test Arch phantom, that its arms are perfectly in a line. It is installed on the HAC dipole positioner with its arms parallel below the dielectric reference wire and able to move elastically in vertical direction without changing its relative position to the top center of the Test Arch phantom. The vertical distance to the probe is adjusted after dipole mounting with a DASY5 Surface Check job. Before the measurement, the distance between phantom surface and probe tip is verified. The proper measurement distance is selected by choosing the matching section of the HAC Test Arch phantom with the proper device reference point (upper surface of the dipole) and the matching grid reference point (tip of the probe) considering the probe sensor offset. The vertical distance to the probe is essential for the accuracy.
- **Feed Point Impedance and Return Loss:** These parameters are measured using a HP 8753E Vector Network Analyzer. The impedance is specified at the SMA connector of the dipole. The influence of reflections was eliminating by applying the averaging function while moving the dipole in the air, at least 70cm away from any obstacles.
- **E-field distribution:** E field is measured in the x-y-plane with an isotropic ER3D-field probe with 100 mW forward power to the antenna feed point. In accordance with [1], the scan area is 20mm wide, its length exceeds the dipole arm length (180 or 90mm). The sensor center is 10 mm (in z) above the top of the dipole arms. Two 3D maxima are available near the end of the dipole arms. Assuming the dipole arms are perfectly in one line, the average of these two maxima (in subgrid 2 and subgrid 8) is determined to compensate for any non-parallelity to the measurement plane as well as the sensor displacement. The E-field value stated as calibration value represents the maximum of the interpolated 3D-E-field, 10mm above the dipole surface.
- **H-field distribution:** H-field is measured with an isotropic H-field probe with 100mW forward power to the antenna feed point, in the x-y-plane. The scan area and sensor distance is equivalent to the E-field scan. The maximum of the field is available at the center (subgrid 5) above the feed point. The H-field value stated as calibration value represents the maximum of the interpolated H-field, 10mm above the dipole surface at the feed point.

1 Measurement Conditions

DASY system configuration, as far as not given on page 1.

DASY Version	DASY5	V52.6.2 (424)
DASY PP Version	SEMCAD X	V14.4.4 (2829)
Phantom	HAC Test Arch	SD HAC P01 BA, #1070
Distance Dipole Top - Probe Center	10 mm	
Scan resolution	dx, dy = 5 mm	area = 20 x 180 mm
Frequency	835 MHz ± 1 MHz	
Forward power at dipole connector	20.0 dBm = 100mW	
Input power drift	< 0.05 dB	

2 Maximum Field values

H-field 10 mm above dipole surface	condition	interpolated maximum
Maximum measured	100 mW forward power	0.470 A/m

Uncertainty for H-field measurement: 8.2% (k=2)

E-field 10 mm above dipole surface	condition	Interpolated maximum
Maximum measured above high end-	100 mW forward power	167.0 V/m
Maximum measured above low end	100 mW forward power	161.0 V/m
Averaged maximum above arm	100 mW forward power	164.0 V/m

Uncertainty for E-field measurement: 12.8% (k=2)

3 Appendix

3.1 Antenna Parameters

Frequency	Return Loss	Impedance
800 MHz	15.6 dB	(42.1 – j13.4) Ohm
835 MHz	23.1 dB	(49.7 + j7.0) Ohm
900 MHz	17.7 dB	(54.7 – j13.0) Ohm
950 MHz	19.3 dB	(44.5 + j8.6) Ohm
960 MHz	15.4 dB	(52.2 + j17.4) Ohm

3.2 Antenna Design and Handling

The calibration dipole has a symmetric geometry with a built-in two stub matching network, which leads to the enhanced bandwidth.

The dipole is built of standard semirigid coaxial cable. The internal matching line is open ended. The antenna is therefore open for DC signals.

Do not apply force to dipole arms, as they are liable to bend. The soldered connections near the feedpoint may be damaged. After excessive mechanical stress or overheating, check the impedance characteristics to ensure that the internal matching network is not affected.

After long term use with 40W radiated power, only a slight warming of the dipole near the feedpoint can be measured.

3.3 Measurement Sheets

3.3.1 Return Loss and Smith Chart

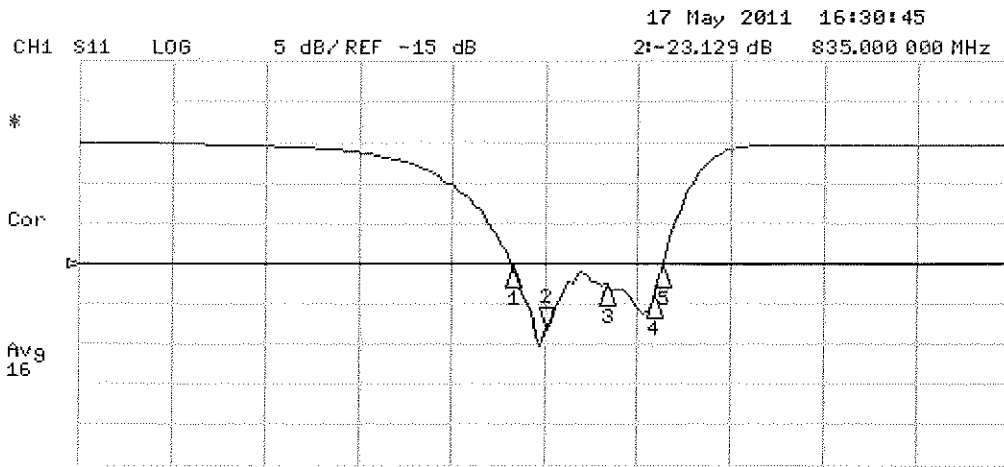

CH2 S11 1 U FS 2: 49.697 Ω 6.9648 Ω 1.3275 nH 835.000 000 MHz

Del

Cor

Avg
16

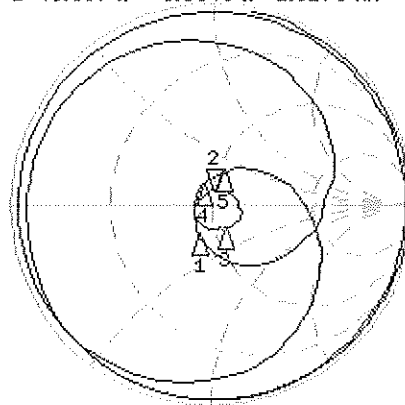

CH2 Markers

1:	42.107 Ω	-13.369 Ω	800.000 MHz
3:	54.705 Ω	-12.904 Ω	900.000 MHz
4:	44.461 Ω	8.6328 Ω	950.000 MHz
5:	52.174 Ω	17.377 Ω	960.000 MHz

START 335.000 000 MHz

STOP 1 335.000 000 MHz

3.3.2 DASY4 H-field Result

Date/Time: 17.05.2011 11:24:17

Test Laboratory: SPEAG Lab2

HAC RF_CD835_1135_H_110517_CL

DUT: HAC-Dipole 835 MHz; Type: CD835V3; Serial: 1135

Communication System: CW; Frequency: 835 MHz

Medium parameters used: $\sigma = 0$ mho/m, $\epsilon_r = 1$; $\rho = 1$ kg/m³

Phantom section: RF Section

Measurement Standard: DASY5 (IEEE/IEC/ANSI C63.19-2007)

DASY5 Configuration:

- Probe: H3DV6 - SN6065; ; Calibrated: 29.12.2010
- Sensor-Surface: (Fix Surface)
- Electronics: DAE4 Sn781; Calibrated: 20.04.2011
- Phantom: HAC Test Arch with AMCC; Type: SD HAC P01 BA; Serial: 1070
- Measurement SW: DASY52, V52.6.2 Build (424)
- Postprocessing SW: SEMCAD X, V14.4.4 Build (2829)

Dipole H-Field measurement @ 835MHz/H Scan - measurement distance from the probe sensor center to CD835

Dipole = 10mm/Hearing Aid Compatibility Test (41x361x1):

Measurement grid: dx=5mm, dy=5mm

Maximum value of peak Total field = 0.470 A/m

Probe Modulation Factor = 1.000

Device Reference Point: 0, 0, -6.3 mm

Reference Value = 0.500 A/m; Power Drift = -0.0058 dB

Hearing Aid Near-Field Category: M4 (AWF 0 dB)

Peak H-field in A/m

Grid 1 0.389 M4	Grid 2 0.410 M4	Grid 3 0.388 M4
Grid 4 0.441 M4	Grid 5 0.470 M4	Grid 6 0.448 M4
Grid 7 0.386 M4	Grid 8 0.414 M4	Grid 9 0.395 M4

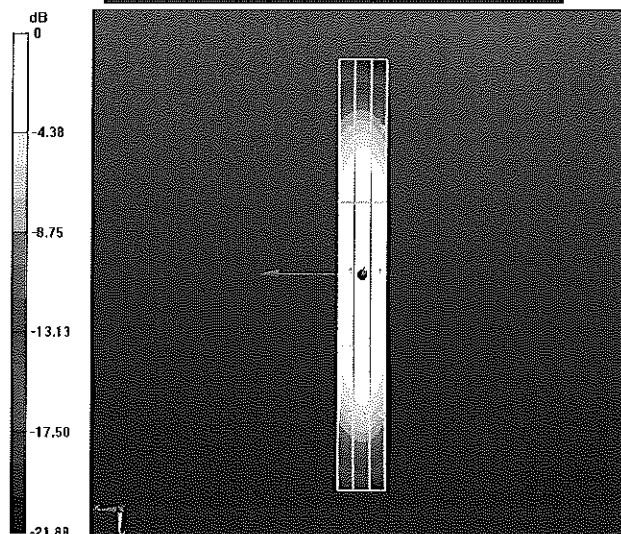

0 dB = 0.470A/m

3.3.3 DASY4 E-field Result

Date/Time: 17.05.2011 15:38:40

Test Laboratory: SPEAG Lab2

HAC RF_CD835_1135_E_110517_CL

DUT: HAC-Dipole 835 MHz; Type: CD835V3; Serial: 1135

Communication System: CW; Frequency: 835 MHz

Medium parameters used: $\sigma = 0$ mho/m, $\epsilon_r = 1$; $\rho = 1000$ kg/m³

Phantom section: RF Section

Measurement Standard: DASY5 (IEEE/IEC/ANSI C63.19-2007)

DASY5 Configuration:

- Probe: ER3DV6 - SN2336; ConvF(1, 1, 1); Calibrated: 29.12.2010
- Sensor-Surface: (Fix Surface)
- Electronics: DAE4 Sn781; Calibrated: 20.04.2011
- Phantom: HAC Test Arch with AMCC; Type: SD HAC P01 BA; Serial: 1070
- Measurement SW: DASY52, V52.6.2 Build (424)
- Postprocessing SW: SEMCAD X, V14.4.4 Build (2829)

Dipole E-Field measurement @ 835MHz/E Scan - measurement distance from the probe sensor center to CD835

Dipole = 10mm/Hearing Aid Compatibility Test (41x361x1):

Measurement grid: dx=5mm, dy=5mm

Maximum value of peak Total field = 167.0 V/m

Probe Modulation Factor = 1.000

Device Reference Point: 0, 0, -6.3 mm

Reference Value = 123.4 V/m; Power Drift = -0.03 dB

Hearing Aid Near-Field Category: M4 (AWF 0 dB)

Peak E-field in V/m

Grid 1 160.8 M4	Grid 2 167.0 M4	Grid 3 160.8 M4
Grid 4 85.238 M4	Grid 5 89.775 M4	Grid 6 88.618 M4
Grid 7 151.3 M4	Grid 8 161.0 M4	Grid 9 159.2 M4

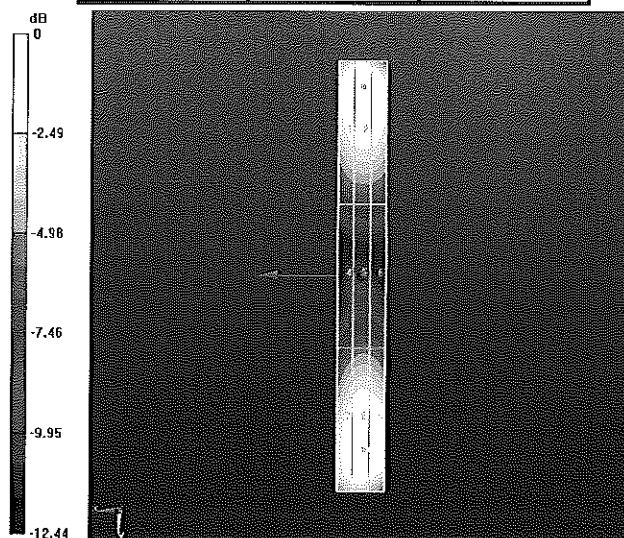

0 dB = 167.0V/m

Calibration Laboratory of
Schmid & Partner
Engineering AG
Zeughausstrasse 43, 8004 Zurich, Switzerland



S Schweizerischer Kalibrierdienst
C Service suisse d'étalonnage
S Servizio svizzero di taratura
S Swiss Calibration Service

Accredited by the Swiss Accreditation Service (SAS)
The Swiss Accreditation Service is one of the signatories to the EA
Multilateral Agreement for the recognition of calibration certificates

Accreditation No.: SCS 108

Client **Quietek (Auden)**

Certificate No: **CD1880V3-1117_May11**

CALIBRATION CERTIFICATE

Object **CD1880V3 - SN: 1117**

Calibration procedure(s) **QA CAL-20.v5
Calibration procedure for dipoles in air**

Calibration date: **May 17, 2011**

This calibration certificate documents the traceability to national standards, which realize the physical units of measurements (SI).
All calibrations have been conducted in the closed laboratory facility: environment temperature (22 ± 3)°C and humidity < 70%.

Calibration Equipment used (M&TE critical for calibration)

Primary Standards	ID #	Cal Date (Certificate No.)	Scheduled Calibration
Power meter EPM-442A	GB37480704	06-Oct-10 (No. 217-01266)	Oct-11
Power sensor HP 8481A	US37292783	06-Oct-10 (No. 217-01266)	Oct-11
Probe ER3DV6	SN: 2336	29-Dec-10 (No. ER3-2336_Dec10)	Dec-11
Probe H3DV6	SN: 6065	29-Dec-10 (No. H3-6065_Dec10)	Dec-11
DAE4	SN: 781	20-Apr-11 (No. DAE4-781_Apr11)	Apr-12
Secondary Standards	ID #	Check Date (in house)	Scheduled Check
Power meter Agilent 4419B	SN: GB42420191	09-Oct-09 (in house check Oct-10)	In house check: Oct-11
Power sensor HP 8482H	SN: 3318A09450	09-Oct-09 (in house check Oct-10)	In house check: Oct-11
Power sensor HP 8482A	SN: US37295597	09-Oct-09 (in house check Oct-10)	In house check: Oct-11
Network Analyzer HP 8753E	US37390585	18-Oct-01 (in house check Oct-10)	In house check: Oct-11
RF generator E4433B	MY 41000675	03-Nov-04 (in house check Oct-09)	In house check: Oct-11

Calibrated by: **Claudio Leubler** Name: Claudio Leubler Function: Laboratory Technician

Signature

Approved by: **Fin Bomholt** Name: Fin Bomholt Function: R&D Director

Signature

Issued: May 17, 2011

This calibration certificate shall not be reproduced except in full without written approval of the laboratory.



Accredited by the Swiss Accreditation Service (SAS)
The Swiss Accreditation Service is one of the signatories to the EA
Multilateral Agreement for the recognition of calibration certificates

Accreditation No.: **SCS 108**

References

- [1] ANSI-C63.19-2007
American National Standard for Methods of Measurement of Compatibility between Wireless Communications Devices and Hearing Aids.

Methods Applied and Interpretation of Parameters:

- *Coordinate System:* y-axis is in the direction of the dipole arms. z-axis is from the basis of the antenna (mounted on the table) towards its feed point between the two dipole arms. x-axis is normal to the other axes. In coincidence with the standards [1], the measurement planes (probe sensor center) are selected to be at a distance of 10 mm above the top edge of the dipole arms.
- *Measurement Conditions:* Further details are available from the hardcopies at the end of the certificate. All figures stated in the certificate are valid at the frequency indicated. The forward power to the dipole connector is set with a calibrated power meter connected and monitored with an auxiliary power meter connected to a directional coupler. While the dipole under test is connected, the forward power is adjusted to the same level.
- *Antenna Positioning:* The dipole is mounted on a HAC Test Arch phantom using the matching dipole positioner with the arms horizontal and the feeding cable coming from the floor. The measurements are performed in a shielded room with absorbers around the setup to reduce the reflections. It is verified before the mounting of the dipole under the Test Arch phantom, that its arms are perfectly in a line. It is installed on the HAC dipole positioner with its arms parallel below the dielectric reference wire and able to move elastically in vertical direction without changing its relative position to the top center of the Test Arch phantom. The vertical distance to the probe is adjusted after dipole mounting with a DASY5 Surface Check job. Before the measurement, the distance between phantom surface and probe tip is verified. The proper measurement distance is selected by choosing the matching section of the HAC Test Arch phantom with the proper device reference point (upper surface of the dipole) and the matching grid reference point (tip of the probe) considering the probe sensor offset. The vertical distance to the probe is essential for the accuracy.
- *Feed Point Impedance and Return Loss:* These parameters are measured using a HP 8753E Vector Network Analyzer. The impedance is specified at the SMA connector of the dipole. The influence of reflections was eliminating by applying the averaging function while moving the dipole in the air, at least 70cm away from any obstacles.
- *E-field distribution:* E field is measured in the x-y-plane with an isotropic ER3D-field probe with 100 mW forward power to the antenna feed point. In accordance with [1], the scan area is 20mm wide, its length exceeds the dipole arm length (180 or 90mm). The sensor center is 10 mm (in z) above the top of the dipole arms. Two 3D maxima are available near the end of the dipole arms. Assuming the dipole arms are perfectly in one line, the average of these two maxima (in subgrid 2 and subgrid 8) is determined to compensate for any non-parallelity to the measurement plane as well as the sensor displacement. The E-field value stated as calibration value represents the maximum of the interpolated 3D-E-field, 10mm above the dipole surface.
- *H-field distribution:* H-field is measured with an isotropic H-field probe with 100mW forward power to the antenna feed point, in the x-y-plane. The scan area and sensor distance is equivalent to the E-field scan. The maximum of the field is available at the center (subgrid 5) above the feed point. The H-field value stated as calibration value represents the maximum of the interpolated H-field, 10mm above the dipole surface at the feed point.

1. Measurement Conditions

DASY system configuration, as far as not given on page 1.

DASY Version	DASY5	V52.6.2 (424)
DASY PP Version	SEMCAD X	V14.4.4 (2829)
Phantom	HAC Test Arch	SD HAC P01 BA, #1070
Distance Dipole Top - Probe Center	10 mm	
Scan resolution	dx, dy = 5 mm	area = 20 x 90 mm
Frequency	1880 MHz ± 1 MHz	
Forward power at dipole connector	20.0 dBm = 100mW	
Input power drift	< 0.05 dB	

2. Maximum Field values

H-field 10 mm above dipole surface	condition	Interpolated maximum
Maximum measured	100 mW forward power	0.476 A/m

Uncertainty for H-field measurement: 8.2% (k=2)

E-field 10 mm above dipole surface	condition	Interpolated maximum
Maximum measured above high end	100 mW forward power	145.0 V/m
Maximum measured above low end	100 mW forward power	139.8 V/m
Averaged maximum above arm	100 mW forward power	142.4 V/m

Uncertainty for E-field measurement: 12.8% (k=2)

3. Appendix

3.1 Antenna Parameters

Frequency	Return Loss	Impedance
1730 MHz	37.0 dB	(51.4 + j0.1) Ohm
1880 MHz	19.8 dB	(45.4 + j8.7) Ohm
1900 MHz	19.6 dB	(47.3 + j9.8) Ohm
1950 MHz	25.0 dB	(52.5 + j5.2) Ohm
2000 MHz	21.6 dB	(43.8 + j4.7) Ohm

3.2 Antenna Design and Handling

The calibration dipole has a symmetric geometry with a built-in two stub matching network, which leads to the enhanced bandwidth.

The dipole is built of standard semirigid coaxial cable. The internal matching line is open ended. The antenna is therefore open for DC signals.

Do not apply force to dipole arms, as they are liable to bend. The soldered connections near the feedpoint may be damaged. After excessive mechanical stress or overheating, check the impedance characteristics to ensure that the internal matching network is not affected.

After long term use with 40W radiated power, only a slight warming of the dipole near the feedpoint can be measured.

3.3 Measurement Sheets

3.3.1 Return Loss and Smith Chart

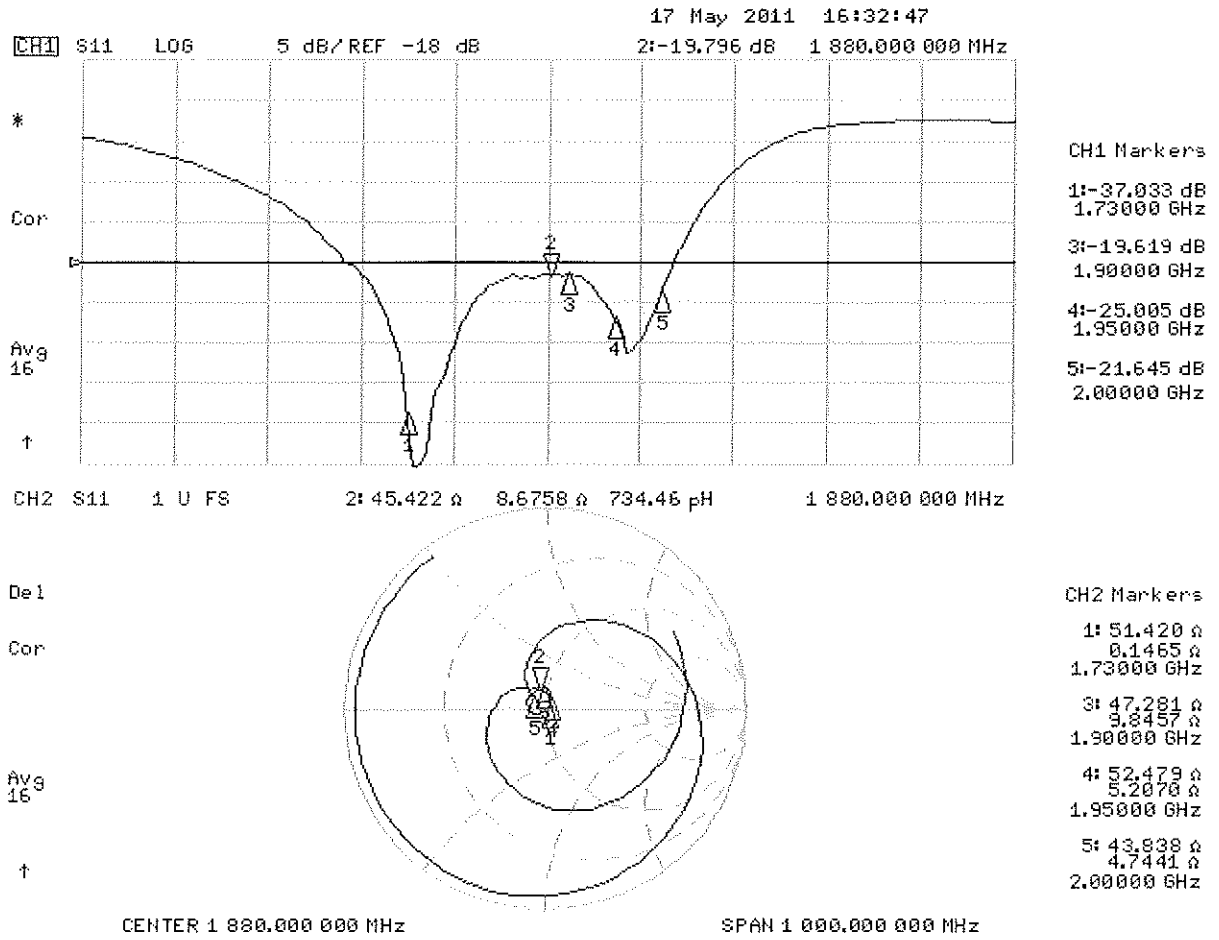

3.3.2 DASY4 H-Field Result

Date/Time: 17.05.2011 11:53:13

Test Laboratory: SPEAG Lab2

HAC_RF_CD1880_1117_H_110517_CL

DUT: HAC Dipole 1880 MHz; Type: CD1880V3; Serial: 1117

Communication System: CW; Frequency: 1880 MHz

Medium parameters used: $\sigma = 0$ mho/m, $\epsilon_r = 1$; $\rho = 1$ kg/m³

Phantom section: RF Section

Measurement Standard: DASY5 (IEEE/IEC/ANSI C63.19-2007)

DASY5 Configuration:

- Probe: H3DV6 - SN6065; ; Calibrated: 29.12.2010
- Sensor-Surface: (Fix Surface)
- Electronics: DAE4 Sn781; Calibrated: 20.04.2011
- Phantom: HAC Test Arch with AMCC; Type: SD HAC P01 BA; Serial: 1070
- Measurement SW: DASY52, V52.6.2 Build (424)
- Postprocessing SW: SEMCAD X, V14.4.4 Build (2829)

Dipole H-Field measurement @ 1880MHz/H Scan - measurement distance from the probe sensor center to CD1880

Dipole = 10mm/Hearing Aid Compatibility Test (41x181x1):

Measurement grid: dx=5mm, dy=5mm

Maximum value of peak Total field = 0.476 A/m

Probe Modulation Factor = 1.000

Device Reference Point: 0, 0, -6.3 mm

Reference Value = 0.504 A/m; Power Drift = -0.0087 dB

Hearing Aid Near-Field Category: M2 (AWF 0 dB)

Peak H-field in A/m

Grid 1 0.408 M2	Grid 2 0.430 M2	Grid 3 0.411 M2
Grid 4 0.450 M2	Grid 5 0.476 M2	Grid 6 0.456 M2
Grid 7 0.416 M2	Grid 8 0.443 M2	Grid 9 0.424 M2

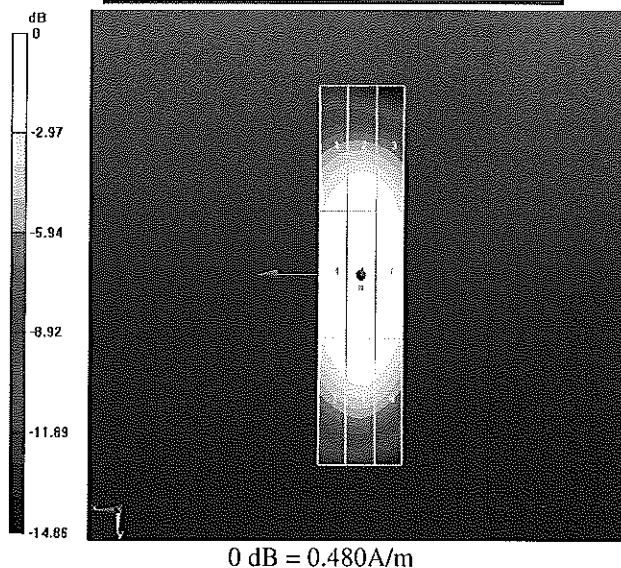

3.3.3 DASY4 E-Field Result

Date/Time: 17.05.2011 15:03:02

Test Laboratory: SPEAG Lab2

HAC_RF_CD1880_1117_E_110517_CL

DUT: HAC Dipole 1880 MHz; Type: CD1880V3; Serial: 1117

Communication System: CW; Frequency: 1880 MHz
 Medium parameters used: $\sigma = 0$ mho/m, $\epsilon_r = 1$; $\rho = 1000$ kg/m³
 Phantom section: RF Section
 Measurement Standard: DASY5 (IEEE/IEC/ANSI C63.19-2007)

DASY5 Configuration:

- Probe: ER3DV6 - SN2336; ConvF(1, 1, 1); Calibrated: 29.12.2010
- Sensor-Surface: (Fix Surface)
- Electronics: DAE4 Sn781; Calibrated: 20.04.2011
- Phantom: HAC Test Arch with AMCC; Type: SD HAC P01 BA; Serial: 1070
- Measurement SW: DASY52, V52.6.2 Build (424)
- Postprocessing SW: SEMCAD X, V14.4.4 Build (2829)

Dipole E-Field measurement @ 1880MHz/E Scan - measurement distance from the probe sensor center to CD1880

Dipole = 10mm/Hearing Aid Compatibility Test (41x181x1):

Measurement grid: dx=5mm, dy=5mm

Maximum value of peak Total field = 145.0 V/m

Probe Modulation Factor = 1.000

Device Reference Point: 0, 0, -6.3 mm

Reference Value = 143.4 V/m; Power Drift = -0.0066 dB

Hearing Aid Near-Field Category: M2 (AWF 0 dB)

Peak E-field in V/m

Grid 1 140.2 M2	Grid 2 145.0 M2	Grid 3 138.6 M2
Grid 4 87.105 M3	Grid 5 92.843 M3	Grid 6 91.846 M3
Grid 7 133.2 M2	Grid 8 139.8 M2	Grid 9 137.3 M2

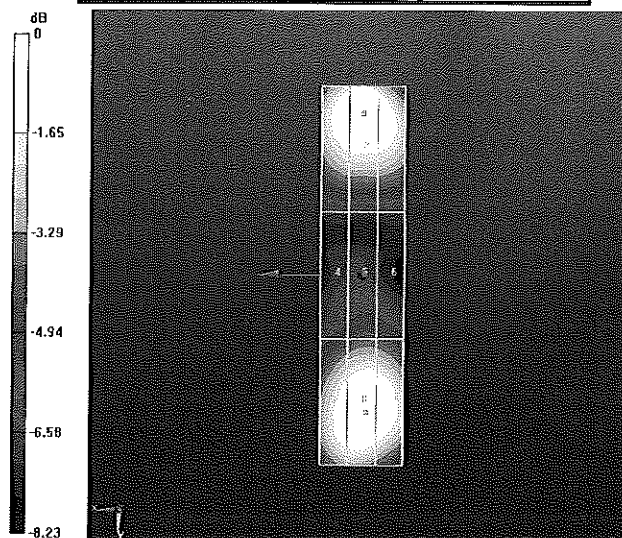

0 dB = 145.0V/m