



---

# SAR Test Report

---

Report No.: AGC00529140202FH01

**FCC ID** : Y7WPLUMAXE  
**APPLICATION PURPOSE** : Original Equipment  
**PRODUCT DESIGNATION** : Axe II 3G  
**BRAND NAME** : plum  
**MODEL NAME** : Z402  
**CLIENT** : CLC Hong Kong Limited  
**DATE OF ISSUE** : Feb.15,2014  
**STANDARD(S)** : IEEE Std. 1528:2003  
: 47CFR § 2.1093  
: IEEE/ANSI C95.1  
**REPORT VERSION** : V1.0

Attestation of Global Compliance(Shenzhen) Co., Ltd.



**CAUTION:**

This report shall not be reproduced except in full without the written permission of the test laboratory and shall not be quoted out of context.

### Report Revise Record

Report Version	Revise Time	Issued Date	Valid Version	Notes
V1.0	/	Feb.15,2014	Valid	Original Report

The test plans were performed in accordance with IEEE Std. 1528:2003; 47CFR § 2.1093; IEEE/ANSI C95.1 and the following specific FCC Test Procedures:

- KDB 447498 D01 General RF Exposure Guidance v05r01
- KDB 648474 D04 SAR Handsets Multi Xmitter and Ant v01
- KDB 865664 D01 SAR measurement 100 MHz to 6 GHz v01
- KDB 941225 D01 SAR test for 3G devices v02
- KDB 941225 D02 Guidance for 3GPP R6 and R7 HSPA v02v01
- KDB 941225 D03 SAR Test Reduction GSM GPRS EDGE v01
- KDB 941225 D06 Hot Spot SAR v01
- KDB 248227 D01 SAR meas for 802 11 a b g v01r02

## Test Report Certification

Applicant Name	CLC Hong Kong Limited
Applicant Address	2209, Concordia Plaza, North Tower, No.1 Science Museum Road, Tsim Sha Tsui East, Kowloon, Hong Kong
Manufacturer Name	CLC Technology Co. Ltd
Manufacturer Address	Room 6G, Block C, NEO Building, Chegongmiao, Futian District, Shenzhen, P.R.China
Product Designation	Axe II 3G
Brand Name	plum
Model Name	Z402
Different Description	N/A
EUT Voltage	DC3.7V by battery
Applicable Standard	IEEE Std. 1528:2003 47CFR § 2.1093 IEEE/ANSI C95.1
Test Date	Jan.25,2014
Performed Location	Attestation of Global Compliance(Shenzhen) Co., Ltd.
	2 F, Building 2, No.1-No.4, Chaxi Sanwei Technical Industrial Park, Gushu, Xixiang Street, Bao'an District, Shenzhen, China
Report Template	AGCRT-US-2.5G/SAR (2013-03-01)

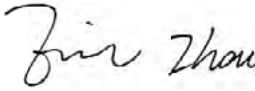
Tested By   
Eric Zhou      Feb.15,2014

Checked By   
Angela Li      Feb.15,2014

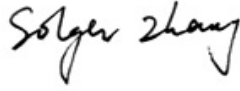
Authorized By   
Solger Zhang      Feb.15,2014

## TABLE OF CONTENTS

<b>1. SUMMARY OF MAXIMUM SAR VALUE .....</b>	<b>5</b>
<b>2. GENERAL INFORMATION .....</b>	<b>7</b>
2.1. EUT DESCRIPTION.....	7
2.2. TEST PROCEDURE .....	9
2.3. TEST ENVIRONMENT.....	9
2.4. TEST CONFIGURATION AND SETTING .....	10
<b>3. SAR MEASUREMENT SYSTEM .....</b>	<b>11</b>
3.1. SPECIFIC ABSORPTION RATE (SAR) .....	11
3.2. SAR MEASUREMENT PROCEDURE .....	12
3.3. COMOSAR SYSTEM DESCRIPTION.....	13
3.4. COMOSAR E-FIELD PROBE .....	15
3.5. ISOTROPIC E-FIELD PROBE SPECIFICATION .....	15
3.6. ROBOT.....	15
3.7. VIDEO POSITIONING SYSTEM .....	16
3.8. DEVICE HOLDER .....	16
3.9. SAM TWIN PHANTOM.....	17
<b>4. TISSUE SIMULATING LIQUID .....</b>	<b>18</b>
4.1. THE COMPOSITION OF THE TISSUE SIMULATING LIQUID.....	18
4.2. TISSUE CALIBRATION RESULT.....	19
4.3. TISSUE DIELECTRIC PARAMETERS FOR HEAD AND BODY PHANTOMS.....	20
<b>5. SAR MEASUREMENT PROCEDURE .....</b>	<b>21</b>
5.1. SAR SYSTEM VALIDATION PROCEDURES .....	21
5.2. SAR SYSTEM VALIDATION.....	22
<b>6. EUT TEST POSITION .....</b>	<b>24</b>
6.1. DEFINE TWO IMAGINARY LINES ON THE HANDSET.....	24
6.2. CHEEK POSITION .....	25
6.3. TITLE POSITION .....	25
6.4. BODY WORN POSITION.....	26
<b>7. SAR EXPOSURE LIMITS .....</b>	<b>27</b>
<b>8. TEST EQUIPMENT LIST .....</b>	<b>28</b>
<b>9. MEASUREMENT UNCERTAINTY .....</b>	<b>29</b>
<b>10. CONDUCTED POWER MEASUREMENT .....</b>	<b>30</b>
<b>11. TEST RESULTS .....</b>	<b>36</b>
11.1. SAR TEST RESULTS SUMMARY .....	36
<b>APPENDIX A. SAR SYSTEM VALIDATION DATA .....</b>	<b>43</b>
<b>APPENDIX B. SAR MEASUREMENT DATA.....</b>	<b>49</b>
<b>APPENDIX C. TEST SETUP PHOTOGRAPHS &amp;EUT PHOTOGRAPHS .....</b>	<b>157</b>
<b>APPENDIX D. PROBE CALIBRATION DATA .....</b>	<b>170</b>
<b>APPENDIX E. DIPOLE CALIBRATION DATA.....</b>	<b>180</b>

## 1. SUMMARY OF MAXIMUM SAR VALUE

The maximum results of Specific Absorption Rate (SAR) found during testing for EUT are as follows:

### Highest Report standalone SAR Summary

Exposure Position	Frequency Band	Highest Tested 1g-SAR(W/Kg)	Highest Scaled Maximum SAR(W/Kg)
Head	GSM 835	0.679	0.855
	PCS 1900	0.453	0.570
	WCDMA Band II	0.826	0.826
	WCDMA Band V	1.208	1.208
Body- worn	GSM 835	0.536	0.675
	PCS 1900	0.407	0.512
	WCDMA Band II	0.906	0.906
	WCDMA Band V	1.213	1.213

Exposure Position	Test Mode	Highest Tested 1g-SAR(W/Kg)	Highest Scaled Maximum SAR(W/Kg)
Head	802.11b	0.351	0.351
	HOTSPOT	0.167	0.167
Body	802.11b	0.351	0.351
	HOTSPOT	0.135	0.135

**Highest Simultaneous transmission SAR Summary**

<b>Exposure Position</b>	<b>Frequency Band</b>	<b>Highest Tested 1g-SAR(W/Kg)</b>	<b>Highest Scaled Maximum SAR(W/Kg)</b>
<b>Head</b>	GSM 835+Bluetooth	0.702	<b>1.297</b>
	GSM 835+WLAN	<b>1.030</b>	
	GSM 835+HOTSPOT	0.846	
	PCS 1900+Bluetooth	0.476	
	PCS 1900+WLAN	0.804	
	PCS 1900+HOTSPOT	0.620	
	WCDMA Band II +Bluetooth	0.849	<b>1.559</b>
	WCDMA Band II+WLAN	1.177	
	WCDMA Band II+HOTSPOT	0.993	
	WCDMA Band V +Bluetooth	1.231	
	WCDMA Band V+WLAN	<b>1.559</b>	
	WCDMA Band V+HOTSPOT	1.375	
<b>Body- worn</b>	GSM 835+Bluetooth	0.559	<b>1.117</b>
	GSM 835+WLAN	<b>0.887</b>	
	GSM 835+HOTSPOT	0.671	
	PCS 1900+Bluetooth	0.430	
	PCS 1900+WLAN	0.758	
	PCS 1900+HOTSPOT	0.542	
	WCDMA Band II +Bluetooth	0.929	<b>1.564</b>
	WCDMA Band II+WLAN	1.257	
	WCDMA Band II+HOTSPOT	1.041	
	WCDMA Band V +Bluetooth	1.236	
	WCDMA Band V+WLAN	<b>1.564</b>	
	WCDMA Band V+HOTSPOT	1.348	

This device is compliance with Specific Absorption Rate (SAR) for general population/uncontrolled exposure limits (1.6W/Kg) specified in FCC 47 CFR part 2 (2.1093) and ANSI/IEEE C95.1, and had been tested in accordance with measurement methods and procedures specified in IEEE 1528-2003 and the relevant KDB files like KDB 941225 D01 , KDB 941225 D03 ,KDB 865664 D02....etc.

## 2. GENERAL INFORMATION

### 2.1. EUT Description

General Information	
Product Designation	Axe II 3G
Test Model	Z402
Hardware Version	V926F-03
Software Version	Axe_II_MT6572_V3.0
Device Category	Portable
RF Exposure Environment	Uncontrolled
Antenna Type	Internal
GSM and GPRS	
Support Band	<input checked="" type="checkbox"/> GSM 850 <input checked="" type="checkbox"/> PCS 1900 (U.S. Bands) <input checked="" type="checkbox"/> GSM 900 <input checked="" type="checkbox"/> DCS 1800 (Non-U.S. Bands)
GPRS Type	Class B
GPRS Class	Class 12(1Tx+4Rx, 2Tx+3Rx, 3Tx+2Rx, 4Tx+1Rx)
TX Frequency Range	GSM 850 : 824.2~848.8MHz; PCS 1900: 1850.2~1909.8MHz;
RX Frequency Range	GSM 850 : 869~894MHz PCS 1900: 1930~1990MHz
Release Version	R99
Type of modulation	GMSK for GSM/GPRS
Antenna Gain	-1.0dBi
Max. Average Power (Max. Peak Power)	GSM850: 31.52dBm(32.45dBm- Peak Power) PCS1900: 28.58dBm(29.49dBm-Peak Power)

**EUT Description( Continue)**

<b>WCDMA</b>	
Support Band	U.S. Bands: <input checked="" type="checkbox"/> UMTS FDD Band II <input checked="" type="checkbox"/> UMTS FDD Band V Non-U.S. Bands: <input checked="" type="checkbox"/> UMTS FDD Band I <input type="checkbox"/> UMTS FDD Band III <input checked="" type="checkbox"/> UMTS FDD Band VIII
HS Type	HSPA(HSUPA/HSDPA)
TX Frequency Range	WCDMA FDD Band II: 1852.4 -1907.6MHz WCDMA FDD Band V: 826.4-846.6MHz
RX Frequency Range	WCDMA FDD Band II: 1930-1990MHz WCDMA FDD Band V: 869-894MHz
Release Version	Rel-6
Type of modulation	QPSK
Antenna Gain	-1.0dBi
Max. Average Power (Max. Peak Power)	Band II: 22.68dBm (23.57dBm- Peak Power) Band V: 22.66dBm (23.54dBm- Peak Power)
<b>Bluetooth</b>	
Bluetooth Version	<input type="checkbox"/> V2.0 <input type="checkbox"/> V2.1 <input type="checkbox"/> V2.1+EDR <input checked="" type="checkbox"/> V3.0 <input type="checkbox"/> V3.0+HS <input checked="" type="checkbox"/> V4.0
Operation Frequency	2402~2480MHz
Type of modulation	<input checked="" type="checkbox"/> GFSK <input checked="" type="checkbox"/> II/4-DQPSK <input checked="" type="checkbox"/> 8-DPSK
Avg. Burst Power	-2.66dBm
Antenna Gain	1.2dBi
<b>WIFI</b>	
WIFI Specification	<input type="checkbox"/> 802.11a <input checked="" type="checkbox"/> 802.11b <input checked="" type="checkbox"/> 802.11g <input checked="" type="checkbox"/> 802.11n(20) <input checked="" type="checkbox"/> 802.11n(40)
Operation Frequency	2412~2462MHz
Avg. Burst Power	11b:9.26dBm,11g:7.77dBm,11n(20):6.32dBm,11n(40):6.44dBm
Antenna Gain	1.2dBi
<b>Accessories</b>	
Battery	Brand name: plum Model No. : PMB37 Voltage and Capacitance: 3.7 V & 1450mAh
Adapter	Brand name: plum Model No. : PMC44 Input: AC 100-240V, 50/60Hz, 0.4A    Output: DC 5V, 600mA
Earphone	Brand name: N/A Model No. : N/A

Note: The sample used for testing is end product.



## 2.2. Test Procedure

1	Setup the EUT and simulators as shown on above.
2	Turn on the power of all equipment.
3	EUT Communicate with 8960, and test them respectively at U.S. bands

## 2.3. Test Environment

Ambient conditions in the laboratory:

Items	Required	Actual
Temperature (°C)	18-25	21± 2
Humidity (%RH)	30-70	55±2

## 2.4. Test Configuration and setting

The EUT is a model of GSM Portable Mobile Station (MS). It supports GSM/GPRS, BT, WIFI, and support hotspot mode.

For WWAN SAR testing, the device was controlled by using a base station emulator. Communication between the device and the emulator were established by air link. The distance between the EUT and the antenna is larger than 50cm, and the output power radiated from the emulator antenna is at least 30db smaller than the output power of EUT.

For WLAN testing, the EUT is configured with the WLAN continuous TX tool through engineering command.

### Antenna Location:

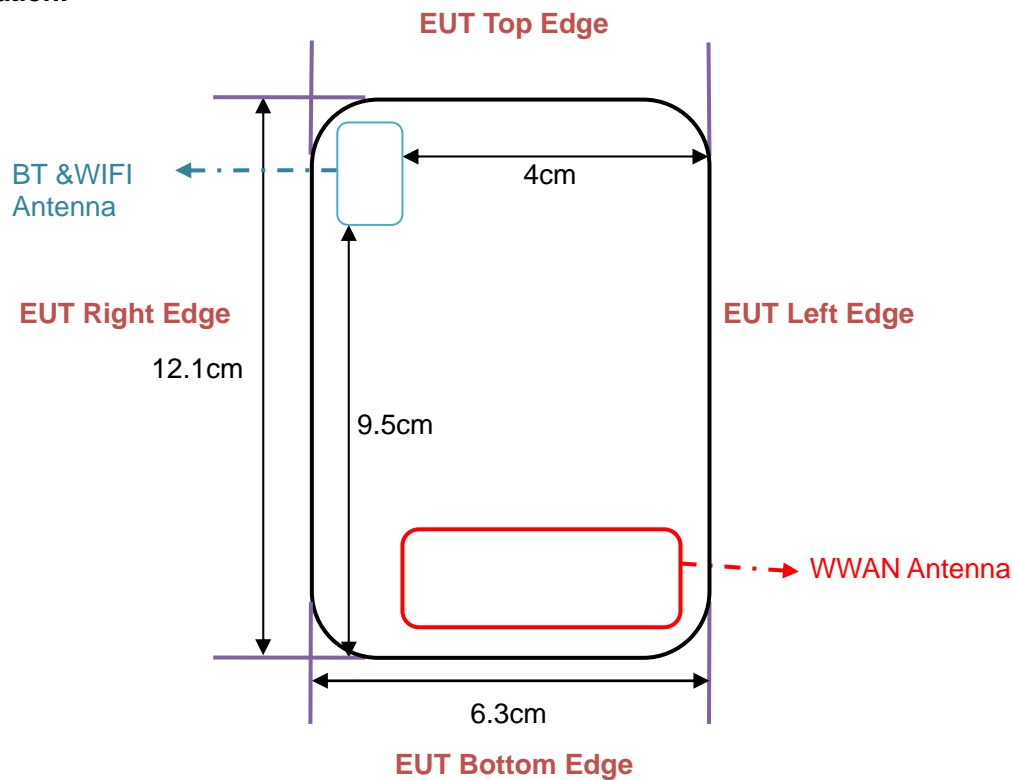

The separation distance for antenna to edge:

Antenna	To Top Side(cm)	To Bottom Side(cm)	To Left Side(cm)	To Right Side(cm)
WWAN	10.1	0.1	0.1	1.5
BT/WIFI	0.1	9.5	4	0.1

The simultaneous transmission possibilities are listed as below:

Simultaneous TX Combination	Configuration	Head	Body	Hotspot
1	GSM835(Voice)+WLAN/BT	Yes	Yes	Yes
2	PCS 1900(Voice)+WLAN/BT	Yes	Yes	Yes
3	WCDMA Band II+WLAN/BT	Yes	Yes	Yes
4	WCDMA Band V+WLAN/BT	Yes	Yes	Yes

### 3. SAR MEASUREMENT SYSTEM

#### 3.1. Specific Absorption Rate (SAR)

SAR is related to the rate at which energy is absorbed per unit mass in object exposed to a radio field. The SAR distribution in a biological body is complicated and is usually carried out by experimental techniques or numerical modeling. The standard recommends limits for two tiers of groups, occupational/controlled and occupational/uncontrolled, based on a person's awareness and ability to exercise control over his or her exposure. In general, occupational/controlled exposure limits are higher than the limits for general population/uncontrolled.

The SAR definition is the time derivative (rate) of the incremental energy (dW) absorbed by (dissipated in) an incremental mass (dm) contained in a volume (dv) of given mass density ( $\rho$ ). The equation description is as below:

$$SAR = \frac{d}{dt} \left( \frac{dW}{dm} \right) = \frac{d}{dt} \left( \frac{dW}{\rho dV} \right)$$

SAR is expressed in units of Watts per kilogram (W/Kg)

SAR can be obtained using either of the following equations:

$$SAR = \frac{\sigma E^2}{\rho}$$

$$SAR = c_h \left. \frac{dT}{dt} \right|_{t=0}$$

Where

SAR	is the specific absorption rate in watts per kilogram;
E	is the r.m.s. value of the electric field strength in the tissue in volts per meter;
$\sigma$	is the conductivity of the tissue in siemens per metre;
$\rho$	is the density of the tissue in kilograms per cubic metre;
$c_h$	is the heat capacity of the tissue in joules per kilogram and Kelvin;

$\left. \frac{dT}{dt} \right|_{t=0}$  is the initial time derivative of temperature in the tissue in kelvins per second

### **3.2. SAR Measurement Procedure**

The EUT is set to transmit at the required power in line with product specification, at each frequency relating to the LOW, MID, and HIGH channel settings.

Pre-scans are made on the device to establish the location for the transmitting antenna, using a large area scan in either air or tissue simulation fluid.

The EUT is placed against the Universal Phantom where the maximum area scan dimensions are larger than the physical size of the resonating antenna. When the scan size is not large enough to cover the peak SAR distribution, it is modified by either extending the area scan size in both the X and Y directions, or the device is shifted within the predefined area.

The area scan is then run to establish the peak SAR location (interpolated resolution set at  $1\text{mm}^2$ ) which is then used to orient the center of the zoom scan. The zoom scan is then executed and the 1g and 10g averages are derived from the zoom scan volume (interpolated resolution set at  $1\text{mm}^3$ ).

When multiple peak SAR location were found during the same configuration or test mode, Zoom scan shall performed on each peak SAR location, only the peak point with maximum SAR value will be reported for the configuration or test mode.

### 3.3. COMOSAR System Description

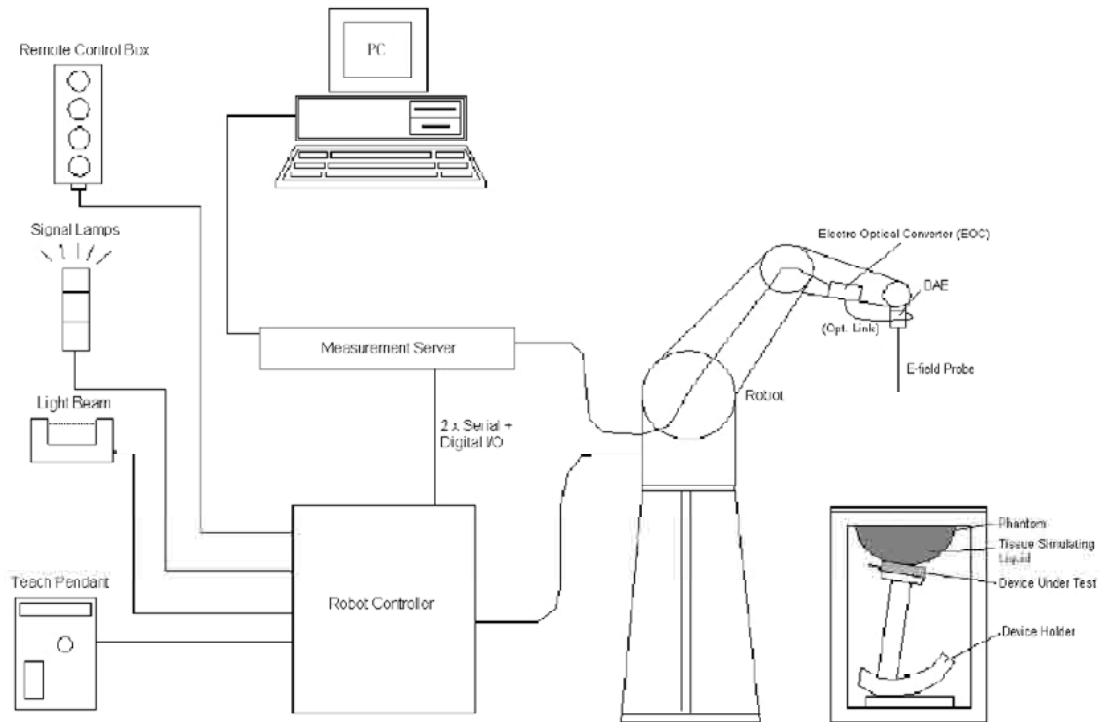

The COMOSAR system for performing compliance tests consists of the following items:

- A standard high precision 6-axis robot with controller, teach pendant and software.
- An arm extension for accommodating the data acquisition electronics (DAE).
- A standard acquisition electronics (DAE) which performs the signal amplification, signal multiplexing, AD-conversion, offset measurements, mechanical surface detection, collision detection, etc. The unit is battery powered with standard or rechargeable batteries. The signal is optically transmitted to the EOC.
- The Electro-optical converter (EOC) performs the conversion from optical to electrical signals for the digital Communicate Mobile to the DAE. To use optical surface detection, a special version of the EOC is required. The EOC signal is transmitted to the measurement server.
- The Light Beam used is for probe alignment. This improves the (absolute) accuracy of the probe positioning.
- A computer running WinXP and the Opensar software.
- Remote control and teach pendant as well as additional circuitry for robot safety such as warning lamps, etc.
- The phantom, the device holder and other accessories according to the targeted measurement.

#### 3.3.1. Applications

Predefined procedures and evaluations for automated compliance testing with all worldwide standards, e.g., IEEE 1528, OET 65, IEC 62209-1, IEC 62209-2, EN 50360, EN 50383 and others.

### 3.3.2. Area Scans

Area scans are defined prior to the measurement process being executed with a user defined variable spacing between each measurement point (integral) allowing low uncertainty measurements to be conducted. Scans defined for FCC applications utilize a 10mm<sup>2</sup> step integral, with 1mm interpolation used to locate the peak SAR area used for zoom scan assessments.

When an Area Scan has measured all reachable points, it computes the field maxima found in the scanned area, within a range of the global maximum. The range (in dB) is specified in the standards for compliance testing. For example, a 2 dB range is required in IEEE 1528-2003, EN 50361 and IEC 62209 standards, whereby 3 dB is a requirement when compliance is assessed in accordance with the ARIB standard (Japan).

### 3.3.3. Zoom Scan (Cube Scan Averaging)

Zoom Scans are used to assess the peak spatial SAR values within a cubic averaging volume containing 1 g and 10 g of simulated tissue. A density of 1000 kg/m<sup>3</sup> is used to represent the head and body tissue density and not the phantom liquid density, in order to be consistent with the definition of the liquid dielectric properties, i.e. the side length of the 1 g cube is 10mm, with the side length of the 10 g cube 21,5mm.

The zoom scan integer steps can be user defined so as to reduce uncertainty, but normal practice for typical test applications utilize a physical step of 7x7x7 (5mmx5mmx5mm) providing a volume of 30mm in the X & Y axis, and 30mm in the Z axis.

### 3.3.4. Uncertainty of Inter-/Extrapolation and Averaging

In order to evaluate the uncertainty of the interpolation, extrapolation and averaged SAR calculation algorithms of the Post processor, COMOSAR allows the generation of measurement grids which are artificially predefined by analytically based test functions. Therefore, the grids of area scans and zoom scans can be filled with uncertainty test data, according to the SAR benchmark functions of IEEE 1528. The three analytical functions shown in equations as below are used to describe the possible range of the expected SAR distributions for the tested handsets. The field gradients are covered by the spatially flat distribution f1, the spatially steep distribution f3 and f2 accounts for H-field cancellation on the phantom/tissue surface.

$$f_1(x, y, z) = A e^{-\frac{z}{2a}} \cos^2 \left( \frac{\pi}{2} \frac{\sqrt{x'^2 + y'^2}}{5a} \right)$$

$$f_2(x, y, z) = A e^{-\frac{z}{a}} \frac{a^2}{a^2 + x'^2} \left( 3 - e^{-\frac{2z}{a}} \right) \cos^2 \left( \frac{\pi}{2} \frac{y'}{3a} \right)$$

$$f_3(x, y, z) = A \frac{a^2}{\frac{a^2}{4} + x'^2 + y'^2} \left( e^{-\frac{2z}{a}} + \frac{a^2}{2(a + 2z)^2} \right)$$

### 3.4. COMOSAR E-Field Probe

The SAR measurement is conducted with the dissymmetric probe manufactured by SATIMO. The probe is specially designed and calibrated for use in liquid with high permittivity. The dissymmetric probe has special calibration in liquid at different frequency. SATIMO conducts the probe calibration in compliance with international and national standards (e.g. IEEE 1528, EN62209-1, IEC 62209, etc.) under ISO17025. The calibration data are in Appendix D.

### 3.5. Isotropic E-Field Probe Specification

<b>Model</b>	EP165	
<b>Manufacture</b>	SATIMO	
<b>Frequency</b>	0.03GHz-3 GHz Linearity:±0.2dB(30 MHz-3 GHz)	
<b>Dynamic Range</b>	0.01W/Kg-100W/Kg Linearity:±0.2dB	
<b>Dimensions</b>	Overall length:330mm Length of individual dipoles:4.5mm Maximum external diameter:8mm Probe Tip external diameter:5mm Distance between dipoles/ probe extremity:2.7mm	
<b>Application</b>	High precision dosimetric measurements in any exposure scenario (e.g., very strong gradient fields). Only probe which enables compliance testing for frequencies up to 3 GHz with precision of better 30%.	

### 3.6. Robot

<p>The COMOSAR system uses the KUKA robot from SATIMO SA (France).For the 6-axis controller COMOSAR system, the KUKA robot controller version from SATIMO is used. The XL robot series have many features that are important for our application:</p> <ul style="list-style-type: none"> <li>High precision (repeatability 0.02 mm)</li> <li>High reliability (industrial design)</li> <li>Jerk-free straight movements</li> <li>Low ELF interference (the closed metallic construction shields against motor control fields)</li> <li>6-axis controller</li> </ul>	
---	---

### 3.7. Video Positioning System

The video positioning system is used in OpenSAR to check the probe. Which is composed of a camera, LED, mirror and mechanical parts. The camera is piloted by the main computer with firewire link. During the process, the actual position of the probe tip with respect to the robot arm is measured, as well as the probe length and the horizontal probe offset. The software then corrects all movements, such that the robot coordinates are valid for the probe tip. The repeatability of this process is better than 0.1 mm. If a position has been taught with an aligned probe, the same position will be reached with another aligned probe within 0.1 mm, even if the other probe has different dimensions. During probe rotations, the probe tip will keep its actual position.

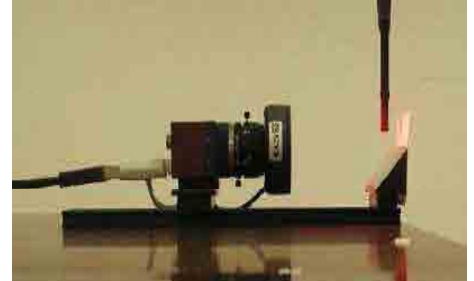

### 3.8. Device Holder

The COMOSAR device holder is designed to cope with different positions given in the standard. It has two scales for the device rotation (with respect to the body axis) and the device inclination (with respect to the line between the ear reference points). The rotation center for both scales is the ear reference point (EPR). Thus the device needs no repositioning when changing the angles. The COMOSAR device holder has been made out of low-loss POM material having the following dielectric parameters: relative permittivity  $\epsilon_r = 3$  and loss tangent  $\delta = 0.02$ . The amount of dielectric material has been reduced in the closest vicinity of the device, since measurements have suggested that the influence of the clamp on the test results could thus be lowered.

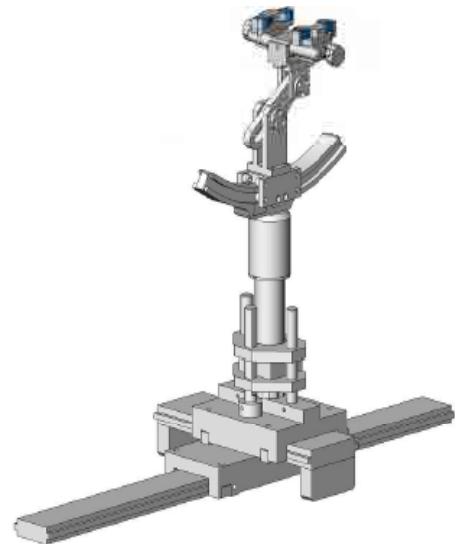



### 3.9. SAM Twin Phantom

The SAM twin phantom is a fiberglass shell phantom with 2mm shell thickness (except the ear region where shell thickness increases to 6mm). It has three measurement areas:

- Left head
- Right head
- Flat phantom



The bottom plate contains three pair of bolts for locking the device holder. The device holder positions are adjusted to the standard measurement positions in the three sections. A white cover is provided to tap the phantom during off-periods to prevent water evaporation and changes in the liquid parameters. On the phantom top, three reference markers are provided to identify the phantom position with respect to the robot.



## 4.2. Tissue Calibration Result

The dielectric parameters of the liquids were verified prior to the SAR evaluation using COMOSAR Dielectric Probe Kit and R&S Network Analyzer ZVL6 .

Tissue Stimulant Measurement for 835MHz							
Fr. (MHz)	Ch.	Dielectric Parameters ( $\pm 5\%$ )				Tissue Temp [°C]	Test time
		head		body			
		$\epsilon_r$ 41.5 39.425-43.575	$\delta$ [s/m] 0.90 0.855-0.945	$\epsilon_r$ 55.20 52.44-57.96	$\delta$ [s/m] 0.97 0.9215-1.0185		
835	Low	41.21	0.87	54.88	0.95	21	Jan.25,2014
835	Mid	41.53	0.92	55.02	0.96	21	Jan.25,2014
835	High	40.87	0.88	55.28	0.95	21	Jan.25,2014

Tissue Stimulant Measurement for 1900MHz							
Fr. (MHz)	Ch.	Dielectric Parameters ( $\pm 5\%$ )				Tissue Temp [°C]	Test time
		head		body			
		$\epsilon_r$ 40.00 38.00-42.00	$\delta$ [s/m] 1.40 1.33-1.47	$\epsilon_r$ 53.30 50.635-55.965	$\delta$ [s/m] 1.52 1.444-1.596		
1900	Low	40.15	1.39	54.01	1.50	21	Jan.25,2014
1900	Mid	39.28	1.4	53.76	1.53	21	Jan.25,2014
1900	High	40.35	1.42	54.29	1.52	21	Jan.25,2014

Tissue Stimulant Measurement for 2450MHz							
Fr. (MHz)	Ch.	Dielectric Parameters ( $\pm 5\%$ )				Tissue Temp [°C]	Test time
		head		body			
		$\epsilon_r$ 39.2 37.24-41.16	$\delta$ [s/m] 1.80 1.71-1.89	$\epsilon_r$ 52.7 50.065-55.335	$\delta$ [s/m] 1.95 1.8525-2.0475		
2450	Low	39.55	1.80	53.26	1.92	21	Jan.25,2014
2450	Mid	39.2	1.83	52.27	1.89	21	Jan.25,2014
2450	High	40.03	1.78	52.79	1.95	21	Jan.25,2014

### 4.3. Tissue Dielectric Parameters for Head and Body Phantoms

The head tissue dielectric parameters recommended by the IEEE SCC-34/SC-2 in P1528 have been incorporated in the following table. These head parameters are derived from planar layer models simulating the highest expected SAR for the dielectric properties and tissue thickness variations in a human head. Other head and body tissue parameters that have not been specified in P1528 are derived from the tissue dielectric parameters computed from the 4-Cole-Cole equations described in Reference [12] and extrapolated according to the head parameters specified in P1528.

Target Frequency (MHz)	head		body	
	$\epsilon_r$	$\sigma$ (S/m)	$\epsilon_r$	$\sigma$ (S/m)
300	45.3	0.87	58.2	0.92
450	43.5	0.87	56.7	0.94
<b>835</b>	<b>41.5</b>	<b>0.90</b>	<b>55.2</b>	<b>0.97</b>
900	41.5	0.97	55.0	1.05
915	41.5	1.01	55.0	1.06
1450	40.5	1.20	54.0	1.30
1610	40.3	1.29	53.8	1.40
<b>1800 – 2000</b>	<b>40.0</b>	<b>1.40</b>	<b>53.3</b>	<b>1.52</b>
<b>2450</b>	<b>39.2</b>	<b>1.80</b>	<b>52.7</b>	<b>1.95</b>
3000	38.5	2.40	52.0	2.73
5800	35.3	5.27	48.2	6.00

( $\epsilon_r$  = relative permittivity,  $\sigma$  = conductivity and  $\rho = 1000$  kg/m<sup>3</sup>)

## 5. SAR MEASUREMENT PROCEDURE

### 5.1. SAR System Validation Procedures

Each SATIMO system is equipped with one or more system validation kits. These units, together with the predefined measurement procedures within the SATIMO software, enable the user to conduct the system performance check and system validation. System kit includes a dipole, and dipole device holder.

The system check verifies that the system operates within its specifications. It's performed daily or before every SAR measurement. The system check uses normal SAR measurement in the flat section of the phantom with a matched dipole at a specified distance. The system validation setup is shown as below.

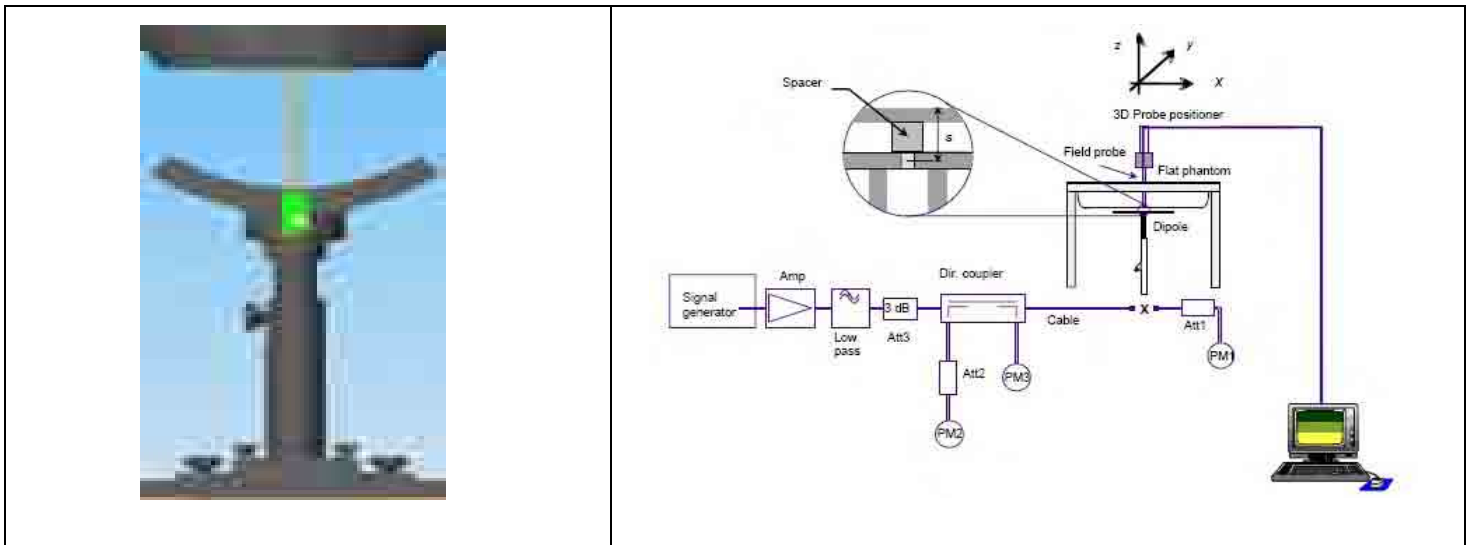

## 5.2. SAR System Validation

### 5.2.1. Validation Dipoles

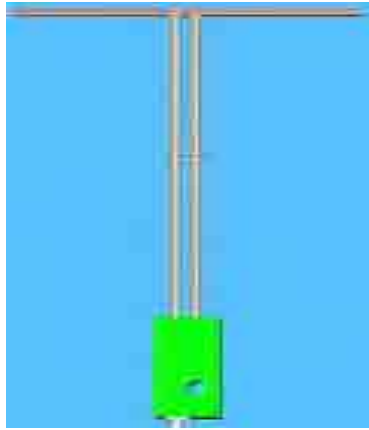

The dipoles used is based on the IEEE-1528 standard, and is complied with mechanical and electrical specifications in line with the requirements of both IEEE and FCC Supplement C. the table below provides details for the mechanical and electrical Specifications for the dipoles.

Frequency	L (mm)	h (mm)	d (mm)
900 MHz	149.0	83.3	3.6
1900MHz	68	39.5	3.6
2450MHz	51.5	30.4	3.6

### 5.2.2. Validation Result

System Performance Check at 835 MHz &1900MHz & 2450MHz for Head								
Validation Kit: SN 46/11DIP 0G900-185 & SN 46/11DIP 1G900-187 &SN 46/11DIP 2G450-189								
Frequency [MHz]	Target Value(W/Kg)		Reference Result ( $\pm 10\%$ )		Tested Value(W/Kg)		Tissue Temp. [°C]	Test time
	1g	10g	1g	10g	1g	10g		
835	10.9	6.99	9.81 -11.99	6.29 - 7.69	10.32	6.75	21	Jan.25,2014
1900	39.7	20.5	35.73 - 43.67	18.45 -22.55	39.84	20.66	21	Jan.25,2014
2450	52.4	24	47.16 - 57.64	21.6 - 26.4	49.53	23.48	21	Jan.25,2014

## 6. EUT TEST POSITION

This EUT was tested in **Right Cheek, Right Titled, Left Cheek, Left Titled, Front Face and Rear Face.**

### 6.1. Define Two Imaginary Lines on the Handset

- (1)The vertical centerline passes through two points on the front side of the handset the midpoint of the width  $w_t$  of the handset at the level of the acoustic output, and the midpoint of the width  $w_b$  of the handset.
- (2)The horizontal line is perpendicular to the vertical centerline and passes through the center of the acoustic output. The horizontal line is also tangential to the face of the handset at point A.
- (3)The two lines intersect at point A. Note that for many handsets, point A coincides with the center of the acoustic output; however, the acoustic output may be located elsewhere on the horizontal line. Also note that the vertical centerline is not necessarily to the front face of the handset, especially for clamshell handsets, handsets with flip covers, and other irregularly shaped handsets.

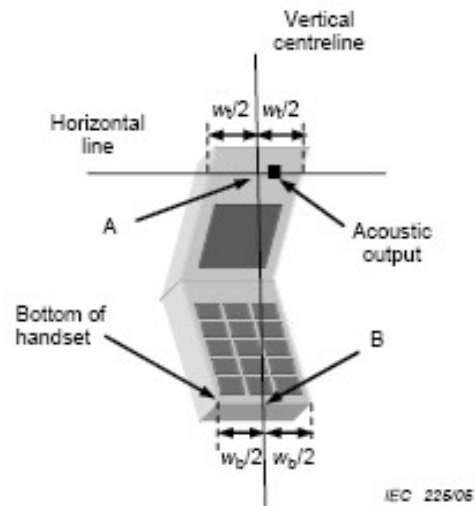
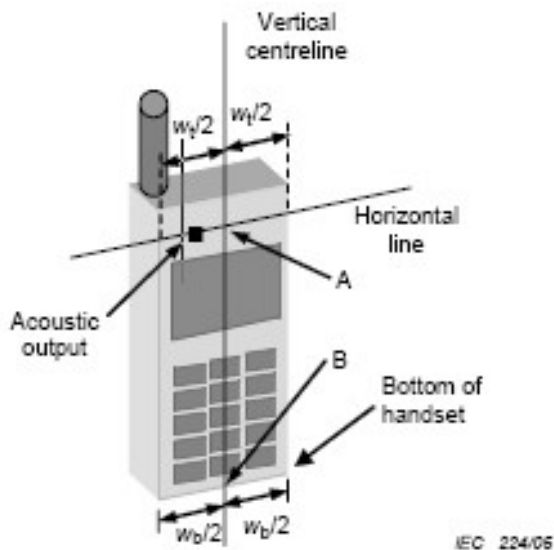



## 6.2. Cheek Position

- (1) To position the device with the vertical center line of the body of the device and the horizontal line crossing the center piece in a plane parallel to the sagittal plane of the phantom. While maintaining the device in this plane, align the vertical center line with the reference plane containing the ear and mouth reference point (M: Mouth, RE: Right Ear, and LE: Left Ear) and align the center of the ear piece with the line RE-LE.
- (2) To move the device towards the phantom with the ear piece aligned with the the line LE-RE until the phone touched the ear. While maintaining the device in the reference plane and maintaining the phone contact with ear, move the bottom of the phone until any point on the front side is in contact with the cheek of the phantom or until contact with the ear is lost

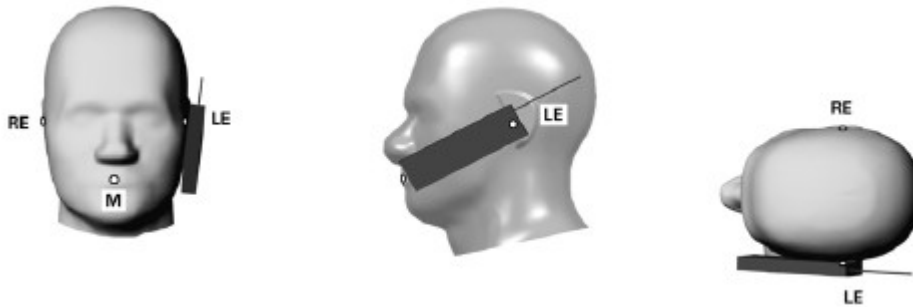

## 6.3. Title Position

- (1) To position the device in the “cheek” position described above.
- (2) While maintaining the device in the reference plane described above and pivoting against the ear, moves it outward away from the mouth by an angle of 15 degrees or until with the ear is lost.



#### 6.4. Body Worn Position

- (1) To position the EUT parallel to the phantom surface.
- (2) To adjust the EUT parallel to the flat phantom.
- (3) To adjust the distance between the EUT surface and the flat phantom to **15mm**. (Hotspot mode the distance of **10mm**).

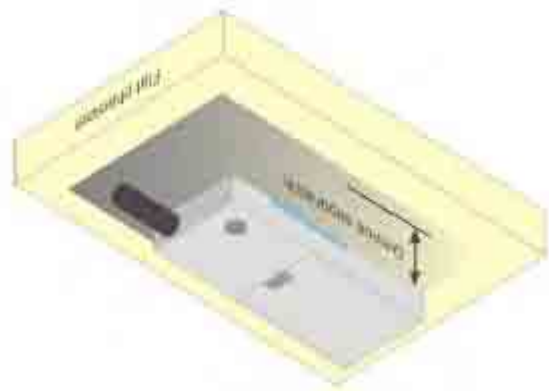
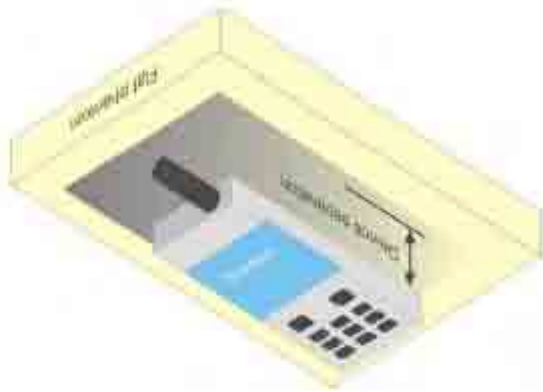

## 7. SAR EXPOSURE LIMITS

SAR assessments have been made in line with the requirements of IEEE-1528, FCC Supplement C, and comply with ANSI/IEEE C95.1-1992 "Uncontrolled Environments" limits. These limits apply to a location which is deemed as "Uncontrolled Environment" which can be described as a situation where the general public may be exposed to an RF source with no prior knowledge or control over their exposure.

### Limits for General Population/Uncontrolled Exposure (W/kg)

Type Exposure	Uncontrolled Environment Limit
Spatial Peak SAR (1g cube tissue for brain or body)	1.60 W/kg

## 8. TEST EQUIPMENT LIST

Equipment description	Manufacturer/ Model	Identification No.	Current calibration date	Next calibration date
SAR Probe	SATIMO	SN 04/13 EP165	01/31/2013	01/30/2014
Phantom	SATIMO	SN_4511_SAM90	Validated. No cal required.	Validated. No cal required.
Liquid	SATIMO	-	Validated. No cal required.	Validated. No cal required.
Comm Tester	R&S - CMU200	069Y7-158-13-712	02/28/2013	02/27/2014
Comm Tester	Agilent-8960	GB46310822	10/22/2013	10/21/2014
Multimeter	Keithley 2000	1188656	02/28/2013	02/27/2014
Dipole	SATIMO SID900	SN46/11 DIP 0G900-185	11/14/2013	11/13/2015
Dipole	SATIMO SID1900	SN46/11 DIP 1G900-187	11/14/2013	11/13/2015
Dipole	SATIMO SID2450	SN46/11 DIP 2G450-189	11/14/2013	11/13/2015
Amplifier	Aethercomm	SN 046	12/08/2013	12/07/2014
Signal Generator	Agilent-E4421B	MY43351603	05/13/2013	05/12/2014
Power Probe	HP E4418A	US38261498	02/28/2013	02/27/2014
SPECTRUM ANALYZER	Agilent/E4440A	MY44303916	10/22/2013	10/21/2014
Power Attenuator	BED	DLA-5W	07/30/2013	07/29/2014
Network Analyzer	Rhode & Schwarz ZVA	SN100132	02/28/2013	02/27/2014

Note: Per KDB 50824 Dipole SAR Validation Verification, AGC Lab has adopted 3 years calibration intervals. On annual basis, every measurement dipole has been evaluated and is in compliance with the following criteria:

1. There is no physical damage on the dipole;
2. System validation with specific dipole is within 10% of calibrated value;
3. Return-loss is within 20% of calibrated measurement;
4. Impedance is within 5Ω of calibrated measurement.

## 9. MEASUREMENT UNCERTAINTY

<b>SATIMO Uncertainty</b>									
Measurement uncertainty for 30 MHz to 3 GHz averaged over 1 gram / 10 gram.									
Error Description	Sec	Sec	Tol (±%)	Prob. Dist.	(Ci) 1g	(Ci) 10g	Std. Unc. (1g) (±%)	Std. Unc. (10g)(±%)	(Vi) Veff
<b>Measurement System</b>									
Probe Calibration	E.2.1	6	N	1	1	1	6	6	∞
Axial Isotropy	E.2.2	3	R	$\sqrt{3}$	$(1 - C_p)^{1/2}$	$(1 - C_p)^{1/2}$	1.22474	1.22474	∞
Hemispherical Isotropy	E.2.2	5	R	$\sqrt{3}$	$\sqrt{C_p}$	$\sqrt{C_p}$	2.04124	2.04124	∞
Boundary Effects	E.2.3	1	R	$\sqrt{3}$	1	1	0.57735	0.57735	∞
Linearity	E.2.4	5	R	$\sqrt{3}$	1	1	2.88675	2.88675	∞
System Detection Limits	E.2.5	1	R	$\sqrt{3}$	1	1	0.57735	0.57735	∞
Readout Electronics	E.2.6	0.5	N	1	1	1	0.5	0.5	∞
Response Time	E.2.7	0.2	R	$\sqrt{3}$	1	1	0.11547	0.11547	∞
Integration Time	E.2.8	2	R	$\sqrt{3}$	1	1	1.1547	1.1547	∞
RF Ambient Noise	E.6.1	3	R	$\sqrt{3}$	1	1	1.73205	1.73205	∞
Probe Positioner Mechanical Tolerance	E.6.2	2	R	$\sqrt{3}$	1	1	1.1547	1.1547	∞
Probe Positioning with Respect to Phantom Shell	E.6.3	1	R	$\sqrt{3}$	1	1	0.57735	0.57735	∞
Extrapolation, interpolation and Integration Algorithms for Max. SAR Evaluation	E.5.2	1.5	R	$\sqrt{3}$	1	1	0.86603	0.86603	∞
<b>Dipole</b>									
Device Positioning	8,E.4.2	1	N	$\sqrt{3}$	1	1	0.57735	0.57735	N-1
Power Drift	8.6.6.2	2	R	$\sqrt{3}$	1	1	1.1547	1.1547	∞
<b>Phantom and Tissue Parameters</b>									
Phantom Uncertainty	E.3.1	4	R	$\sqrt{3}$	1	1	2.3094	2.3094	∞
Liquid Conductivity (target)	E.3.2	5	R	$\sqrt{3}$	0.64	0.43	1.84752	1.2413	∞
Liquid Conductivity (meas.)	E.3.3	2.5	N	1	0.64	0.43	1.6	1.075	∞
Liquid Permittivity (target)	E.3.2	3	R	$\sqrt{3}$	0.6	0.49	1.03923	0.8487	∞
Liquid Permittivity (meas.)	E.3.3	2.5	N	1	0.6	0.49	1.5	1.225	M
Combined Standard Uncertainty			RSS				8.09272	7.9296	
Expanded Uncertainty (95%CONFIDENCE INTERVAL)			k				16.18544	15.8592	

## 10. CONDUCTED POWER MEASUREMENT GSM BAND

Mode	Frequency(MHz)	Avg. Burst Power(dBm)	Duty cycle Factor(dBm)	Frame Power(dBm)
Maximum Power <1>				
GSM 900	880.2	<b>31.52</b>	-9	22.52
	897.4	31.43	-9	22.43
	914.8	31.38	-9	22.38
GPRS 900 (1 Slot)	880.2	31.28	-9	22.28
	897.4	31.24	-9	22.24
	914.8	31.17	-9	22.17
GPRS 900 (2 Slot)	880.2	28.48	-6	22.48
	897.4	28.33	-6	22.33
	914.8	28.27	-6	22.27
GPRS 900 (3 Slot)	880.2	26.54	-4.26	22.28
	897.4	26.48	-4.26	22.22
	914.8	26.36	-4.26	22.10
GPRS 900 (4 Slot)	880.2	25.52	-3	22.52
	897.4	25.46	-3	22.46
	914.8	25.37	-3	22.37
EGPRS 900 (1 Slot)	880.20	26.78	-9	17.78
	897.40	26.35	-9	17.35
	914.80	26.13	-9	17.13
EGPRS 900 (2 Slot)	880.20	23.24	-6	17.24
	897.40	23.03	-6	17.03
	914.80	23.32	-6	17.32
EGPRS 900 (3 Slot)	880.20	22.34	-4.26	18.08
	897.40	22.08	-4.26	17.82
	914.80	22.17	-4.26	17.91
EGPRS 900 (4 Slot)	880.20	21.47	-3	18.47
	897.40	20.88	-3	17.88
	914.80	21.12	-3	18.12
DCS1800	1710.2	28.54	-9	19.54
	1747.4	<b>28.58</b>	-9	19.58
	1784.8	28.46	-9	19.46
GPRS1800 (1 Slot)	1710.2	28.36	-9	19.36
	1747.4	28.33	-9	19.33
	1784.8	28.24	-9	19.24
GPRS1800 (2 Slot)	1710.2	25.33	-6	19.33
	1747.4	25.45	-6	19.45
	1784.8	25.36	-6	19.36
GPRS1800 (3 Slot)	1710.2	24.48	-4.26	20.22
	1747.4	24.52	-4.26	20.26
	1784.8	24.39	-4.26	20.13

GPRS1800 (4 Slot)	1710.2	22.48	-3	19.48
	1747.4	22.57	-3	19.57
	1784.8	22.46	-3	19.46
EGPRS1800 (1 Slot)	1710.2	25.38	-9	16.38
	1747.4	25.72	-9	16.72
	1784.8	25.27	-9	16.27
EGPRS1800 (2 Slot)	1710.2	22.86	-6	16.86
	1747.4	23.16	-6	17.16
	1784.8	22.24	-6	16.24
EGPRS1800 (3 Slot)	1710.2	23.15	-4.26	18.89
	1747.4	23.45	-4.26	19.19
	1784.8	22.11	-4.26	17.85
EGPRS1800 (4 Slot)	1710.2	20.31	-3	17.31
	1747.4	20.33	-3	17.33
	1784.8	20.26	-3	17.26
Maximum Power <2>				
GSM 900	897.4	31.02	-9	22.02
DCS1800	1747.4	28.09	-9	19.09

Note 1:

The Frame Power (Source-based time-averaged Power) is scaled the maximum burst average power based on time slots. The calculated methods are show as following:

Frame Power = Max burst power (1 Up Slot) – 9 dB

Frame Power = Max burst power (2 Up Slot) – 6 dB

Frame Power = Max burst power (3 Up Slot) -4.26dB

Frame Power = Max burst power (4 Up Slot) – 3 dB

**UMTS BAND II**

<b>Mode</b>	<b>Frequency (MHz)</b>	<b>Avg.Burst Power</b>
WCDMA 1900 RMC	1852.4	<b>22.68</b>
	1880	22.61
	1907.6	22.52
WCDMA 1900 AMR	1852.4	22.33
	1880	22.24
	1907.6	22.18
HSDPA Subtest 1	1852.4	22.36
	1880	22.24
	1907.6	22.21
HSDPA Subtest 2	1852.4	22.34
	1880	22.23
	1907.6	22.17
HSDPA Subtest 3	1852.4	22.32
	1880	22.26
	1907.6	22.21
HSDPA Subtest 4	1852.4	22.43
	1880	22.35
	1907.6	22.23
HSUPA Subtest 1	1852.4	22.32
	1880	22.25
	1907.6	22.13
HSUPA Subtest 2	1852.4	22.16
	1880	22.11
	1907.6	22.08
HSUPA Subtest 3	1852.4	22.25
	1880	22.21
	1907.6	22.14
HSUPA Subtest 4	1852.4	22.33
	1880	22.27
	1907.6	22.12
HSUPA Subtest 5	1852.4	22.29
	1880	22.25
	1907.6	22.13



**UMTS BAND V**

<b>Mode</b>	<b>Frequency (MHz)</b>	<b>Avg.Burst Power</b>
WCDMA 835 RMC	826.4	<b>22.66</b>
	835.0	22.57
	846.6	22.48
WCDMA 835 AMR	826.4	22.39
	835.0	22.32
	846.6	22.28
HSDPA Subtest 1	826.4	22.26
	835.0	22.13
	846.6	22.18
HSDPA Subtest 2	826.4	22.41
	835.0	22.33
	846.6	22.38
HSDPA Subtest 3	826.4	22.37
	835.0	22.32
	846.6	22.27
HSDPA Subtest 4	826.4	22.42
	835.0	22.29
	846.6	22.38
HSUPA Subtest 1	826.4	22.26
	835.0	22.08
	846.6	22.24
HSUPA Subtest 2	826.4	22.27
	835.0	22.11
	846.6	22.16
HSUPA Subtest 3	826.4	22.27
	835.0	22.17
	846.6	22.12
HSUPA Subtest 4	826.4	22.33
	835.0	22.24
	846.6	22.16
HSUPA Subtest 5	826.4	22.34
	835.0	22.15
	846.6	22.16

**WIFI**

Mode	Data Rate (Mbps)	Channel	Frequency(MHz)	Avg. Burst Power(dBm)
802.11b	1	01	2412	9.14
		06	2437	<b>9.26</b>
		11	2462	8.76
802.11g	6	01	2412	6.07
		06	2437	7.77
		11	2462	5.89
802.11n(20)	6.5	01	2412	6.16
		06	2437	6.32
		11	2462	5.88
802.11n(40)	13.5	03	2422	3.34
		06	2437	6.44
		09	2452	3.29

**Bluetooth\_V3.0**

Modulation	Channel	Frequency(MHz)	Average Power (dBm)
GFSK	0	2402	-3.59
	39	2441	-3.13
	78	2480	<b>-2.66</b>
$\pi$ /4-DQPSK	0	2402	-4.5
	39	2441	-3.93
	78	2480	-3.47
8-DPSK	0	2402	-4.63
	39	2441	-4.03
	78	2480	-3.59

According to 3GPP 25.101 sub-clause 6.2.2 , the maximum output power is allowed to be reduced by following the table.

Table 6.1aA: UE maximum output power with HS-DPCCH and E-DCH

UE Transmit Channel Configuration	CM(db)	MPR(db)
For all combinations of ,DPDCH,DPCCH HS-DPDCH,E-DPDCH and E-DPCCH	$0 \leq CM \leq 3.5$	MAX(CM-1,0)
Note: CM=1 for $\beta_c/\beta_d=12/15$ , $\beta_{hs}/\beta_c=24/15$ .For all other combinations of DPDCH, DPCCH, HS-DPCCH, E-DPDCH and E-DPCCH the MPR is based on the relative CM difference.		

The device supports MPR to solve linearity issues (ACLR or SEM) due to the higher peak-to average ratios (PAR) of the HSUPA signal. This prevents saturating the full range of the TX DAC inside of device and provides a reduced power output to the RF transceiver chip according to the Cubic Metric (a function of the combinations of DPDCH, DPCCH, HS-DPCCH, E-DPDCH and E-DPCCH).

When E-DPDCH channels are present the beta gains on those channels are reduced firsts to try to get the power under the allowed limit. If the beta gains are lowered as far as possible, then a hard limiting is applied at the maximum allowed level.

The SW currently recalculates the cubic metric every time the beta gains on the E-DPDCH are reduced. The cubic metric will likely get lower each time this is done .However, there is no reported reduction of maximum output power in the HSUPA mode since the device also provides a compensation for the power back-off by increasing the gain of TX\_AGC in the transceiver (PA) device.

The end effect is that the DUT output power is identical to the case where there is no MPR in the device.

## 11. TEST RESULTS

### 11.1. SAR Test Results Summary

#### 11.1.1. Test position and configuration

Head SAR was performed with the device configured in the positions according to IEEE1528, and Body SAR was performed with the device 15mm from the phantom; Body SAR was also performed with the headset attached and without. The overall device length and width(12.1cm×6.3cm) are >9cm×5cm, Hotspot mode with a test separation distance of 10mm.

#### 11.1.2. Operation Mode

- According to KDB 447498 D01 v05r01 ,for each exposure position, if the highest 1-g SAR is  $\leq 0.8$  W/kg, testing for low and high channel is optional.
- Per KDB 865664 D01 v01r01,for each frequency band, if the measured SAR is  $\geq 0.8$ W/Kg, testing for repeated SAR measurement is required , that the highest measured SAR is only to be tested. When the SAR results are near the limit, the following procedures are required for each device to verify these types of SAR measurement related variation concerns by repeating the highest measured SAR configuration in each frequency band.
  - (1) When the original highest measured SAR is  $\geq 0.8$ W/Kg, repeat that measurement once.
  - (2) Perform a second repeated measurement only if the ratio of largest to smallest SAR for the original and first repeated measurements is  $> 1.20$  or when the original or repeated measurement is  $\geq 1.45$  W/Kg.
  - (3) Perform a third repeated measurement only if the original, first and second repeated measurement is  $\geq 1.5$  W/Kg and ratio of largest to smallest SAR for the original, first and second measurement is  $\geq 1.20$ .
- Body-worn exposure conditions are intended to voice call operations, therefore GSM voice call mode is selected to be test.
- According to KDB 648474 D04 v01r01,when the reported SAR for a body-worn accessory measured without a headset connected to the handset is  $\leq 1.2$ W/Kg, SAR testing with a headset connected is not required.
- According to 941225 D06, when the overall device length and width are >9cm×5cm, Hotspot mode with a test separation distance of 10mm. For device with form factors smaller than 9cm×5cm, Hotspot mode with a test separation distance of 5mm. Body SAR was also performed with the headset attached and without.
- According to 248227 D01, SAR is not required for 802.11g channels when the maximum average output power is less than 1/4dB higher than measured on the corresponding 802.11b channels.
- Maximum Scaling SAR in order to calculate the Maximum SAR values to test under the standard Peak Power, Calculation method is as follows:  
Maximum Scaling SAR =tested SAR (Max.) × GSM[maximum turn-up power (mw)/ maximum measurement output power(mw) ]

### 11.1.3. Test Result

SAR MEASUREMENT									
Ambient Temperature (°C) : 21 ± 2					Relative Humidity (%): 55				
Liquid Temperature (°C) : 21 ± 2					Depth of Liquid (cm):>15				
Product: Axe II 3G									
Test Mode: GSM835 with GMSK modulation									
Position	Mode	Ch.	Fr. (MHz)	Power Drift (<±5%)	SAR (1g) (W/kg)	Max. Turn-up Power (dBm)	Meas. output Power (dBm)	Scaled SAR (W/Kg)	Limit W/kg
<b>SIM 1 Card</b>									
Left Cheek	voice	190	836.6	1.38	0.446	32.52	31.52	0.561	1.6
Left Tilt	voice	190	836.6	0.91	0.294	32.52	31.52	0.370	1.6
Right Cheek	voice	190	836.6	2.06	<b>0.679</b>	32.52	31.52	<b>0.855</b>	1.6
Right Tilt	voice	190	836.6	-0.23	0.429	32.52	31.52	0.540	1.6
Body back	voice	190	836.6	-1.08	<b>0.536</b>	32.52	31.52	<b>0.675</b>	1.6
Body front	voice	190	836.6	0.49	0.399	32.52	31.52	0.502	1.6
<b>SIM 2 Card</b>									
Right Cheek	voice	190	836.6	1.57	0.592	32.52	31.52	0.745	1.6

Note:

- The test separation of all above table for body is 15mm.
- when the 1-g SAR is ≤ 0.8 W/kg, testing for low and high channel is optional. refer to KDB 941225.

SAR MEASUREMENT									
Ambient Temperature (°C) : 21 ± 2					Relative Humidity (%): 55				
Liquid Temperature (°C) : 21 ± 2					Depth of Liquid (cm):>15				
Product: Axe II 3G									
Test Mode: GSM1900 with GMSK modulation									
Position	Mode	Ch.	Fr. (MHz)	Power Drift (<±5%)	SAR (1g) (W/kg)	Max. Turn-up Power (dBm)	Meas. output Power (dBm)	Scaled SAR (W/Kg)	Limit W/kg
<b>SIM 1 Card</b>									
Left Cheek	voice	661	1880.0	2.37	0.415	29.58	28.58	0.522	1.6
Left Tilt	voice	661	1880.0	1.02	0.449	29.58	28.58	0.565	1.6
Right Cheek	voice	661	1880.0	1.95	<b>0.453</b>	29.58	28.58	<b>0.570</b>	1.6
Right Tilt	voice	661	1880.0	0.84	0.418	29.58	28.58	0.526	1.6
Body back	voice	661	1880.0	1.52	<b>0.407</b>	29.58	28.58	<b>0.512</b>	1.6
Body front	voice	661	1880.0	0.77	0.289	29.58	28.58	0.364	1.6
<b>SIM 2 Card</b>									
Right Cheek	voice	661	1880.0	1.59	0.390	29.58	28.58	0.491	1.6

Note:

- The test separation of all above table for body is 15mm.
- when the 1-g SAR is ≤ 0.8 W/kg, testing for low and high channel is optional. refer to KDB 941225.

SAR MEASUREMENT									
Ambient Temperature (°C) : 21 ± 2					Relative Humidity (%): 55				
Liquid Temperature (°C) : 21 ± 2					Depth of Liquid (cm):>15				
Product: Axe II 3G									
Test Mode: WCDMA Band II with QPSK modulation									
Position	Mode	Ch.	Fr. (MHz)	Power Drift (<±5%)	SAR (1g) (W/kg)	Max. Turn-up Power (dBm)	Meas. output Power (dBm)	Scaled SAR (W/Kg)	Limit W/kg
<b>SIM 1 Card</b>									
Left Cheek	voice	9400	1880	1.54	0.561	22.68	22.68	0.561	1.6
Left Tilt	voice	9400	1880	1.36	0.251	22.68	22.68	0.251	1.6
Right Cheek	voice	9262	1852.4	1.59	0.815	22.68	22.68	0.815	1.6
Right Cheek	voice	9400	1880	1.84	<b>0.826</b>	22.68	22.68	<b>0.826</b>	1.6
Right Cheek	voice	9538	1907.6	1.27	0.772	22.68	22.68	0.772	1.6
Right Tilt	voice	9400	1880	1.55	0.236	22.68	22.68	0.236	1.6
Body back	voice	9262	1852.4	1.69	<b>0.906</b>	22.68	22.68	<b>0.906</b>	1.6
Body back	voice	9400	1880	1.77	0.848	22.68	22.68	0.848	1.6
Body back	voice	9538	1907.6	1.26	0.807	22.68	22.68	0.807	1.6
Body front	voice	9400	1880	1.59	0.616	22.68	22.68	0.616	1.6

Note:

- The test separation of all above table for body is 15mm.
- when the 1-g SAR is ≤ 0.8 W/kg, testing for low and high channel is optional. refer to KDB 941225.

SAR MEASUREMENT									
Ambient Temperature (°C) : 21 ± 2					Relative Humidity (%): 55				
Liquid Temperature (°C) : 21 ± 2					Depth of Liquid (cm):>15				
Product: Axe II 3G									
Test Mode: WCDMA Band V with QPSK modulation									
Position	Mode	Ch.	Fr. (MHz)	Power Drift (<±5%)	SAR (1g) (W/kg)	Max. Turn-up Power (dBm)	Meas. output Power (dBm)	Scaled SAR (W/Kg)	Limit W/kg
<b>SIM 1 Card</b>									
Left Cheek	voice	4132	826.4	0.77	0.990	22.66	22.66	0.990	1.6
Left Cheek	voice	4182	835.0	1.23	1.054	22.66	22.66	1.054	1.6
Left Cheek	voice	4233	846.6	0.59	1.026	22.66	22.66	1.026	1.6
Left Tilt	voice	4182	835.0	1.54	0.573	22.66	22.66	0.573	1.6
Right Cheek	voice	4132	826.4	2.06	1.099	22.66	22.66	1.099	1.6
Right Cheek	voice	4182	835.0	-0.74	1.117	22.66	22.66	1.117	1.6
Right Cheek	voice	4233	846.6	0.15	<b>1.208</b>	22.66	22.66	<b>1.208</b>	1.6
Right Tilt	voice	4182	835.0	0.66	0.690	22.66	22.66	0.690	1.6
Body back	voice	4132	826.4	1.26	1.174	22.66	22.66	1.174	1.6
Body back	voice	4182	835.0	2.03	1.067	22.66	22.66	1.067	1.6
Body back	voice	4233	846.6	1.28	<b>1.213</b>	22.66	22.66	<b>1.213</b>	1.6
Body front	voice	4132	826.4	0.51	0.923	22.66	22.66	0.923	1.6
Body front	voice	4182	835.0	0.91	0.903	22.66	22.66	0.903	1.6
Body front	voice	4233	846.6	0.38	0.953	22.66	22.66	0.953	1.6
Body back	voice with earphone	4132	826.4	0.78	0.908	22.66	22.66	0.908	1.6
Body back	voice with earphone	4182	835.0	0.14	0.961	22.66	22.66	0.961	1.6
Body back	voice with earphone	4233	846.6	0.96	0.984	22.66	22.66	0.984	1.6

Note:

- The test separation of all above table for body is 15mm.
- when the 1-g SAR is ≤ 0.8 W/kg, testing for low and high channel is optional. refer to KDB 941225.

Repeated SAR								
Ambient Temperature (°C) : 21 ± 2				Relative Humidity (%): 55				
Liquid Temperature (°C) : 21 ± 2				Depth of Liquid (cm):>15				
Product: Axe II 3G								
Test Mode: WCDMA Band II&WCDMA Band V with QPSK modulation								
Position	Mode	Ch.	Fr. (MHz)	Power Drift (<±5%)	Once SAR (1g) (W/kg)	Twice SAR (1g) (W/kg)	Third SAR (1g) (W/kg)	Limit W/kg
Right Cheek	voice	9400	1880	1.33	0.805	--	--	1.6
Body back	voice	9262	1852.4	2.06	0.869	--	--	1.6
Right Cheek	voice	4233	846.6	0.59	1.166	1.050	--	1.6
Body back	voice	4233	846.6	0.81	1.104	1.147	--	1.6
Body back	voice with earphone	4233	846.6	0.87	0.975	--	--	1.6

SAR MEASUREMENT									
Ambient Temperature (°C) : 21 ± 2				Relative Humidity (%): 55					
Liquid Temperature (°C) : 21 ± 2				Depth of Liquid (cm):>15					
Product: Axe II 3G									
Test Mode: Hotspot									
Position	Mode	Ch.	Fr. (MHz)	Power Drift (<±5%)	SAR (1g) (W/kg)	Max. Turn-up Power (dBm)	Meas. output Power (dBm)	Scaled SAR (W/Kg)	Limit W/kg
<b>SIM 1 Card</b>									
Left Cheek	voice	6	2437	1.30	<b>0.167</b>	9.26	9.26	<b>0.167</b>	1.6
Left Tilt	voice	6	2437	0.91	0.075	9.26	9.26	0.075	1.6
Right Cheek	voice	6	2437	1.36	0.123	9.26	9.26	0.123	1.6
Right Tilt	voice	6	2437	1.59	0.095	9.26	9.26	0.095	1.6
Body back	DTS	6	2437	0.48	<b>0.135</b>	9.26	9.26	<b>0.135</b>	1.6
Body front	DTS	6	2437	0.81	0.067	9.26	9.26	0.067	1.6

Note:

- According to KDB248227, SAR is not required for 802.11n HT20/HT40 channels when the maximum average output power is less than 1/4 dB higher than that measured on the corresponding 802.11a/b channels.
- All of above "DTS" means data transmitters.
- The test separation of all above table for body is 10mm.
- when the 1-g SAR is ≤ 0.8 W/kg, testing for low and high channel is optional. refer to KDB 941225.



**Simultaneous Multi-band Transmission Evaluation:**  
**Application Simultaneous Transmission information:**

Position	Simultaneous state
Head	1.WWAN(voice)+WLAN 2.4GHz band
	2.WWAN(voice)+Bluetooth
	3.WWAN(voice)+ HOTSPOT 2.4GHz band
Body	4. WWAN(voice)+WLAN 2.4GHz band
	5. WWAN(voice)+Bluetooth
	6.WWAN(voice)+ HOTSPOT 2.4GHz band

**NOTE:**

- WLAN and BT share the same antenna, and cannot transmit simultaneously.
- Simultaneous with every transmitter must be the same test position.
- Based upon KDB 447498 D01 v05, BT SAR is excluded as below table.
- Based upon KDB 447498 D01 v05,for handsets the test separation distance is determined by the smallest distance between the outer surface of the device and the user; which is 0mm for head SAR AND 15mm for body-worn SAR.
- If the test separation distance is <5mm, 5mm is used for excluded SAR calculation.
- For minimum test separation distance  $\leq 50$ mm,Bluetooth standalone SAR is excluded according to  $[(\text{max. power of channel, including tune-up tolerance, mW}) / (\text{min. test separation distance, mm}) \cdot \sqrt{f \text{ (GHz)}} / x] \leq 3.0$  for 1-g SAR and  $\leq 7.5$  for 10-g extremity SAR
- KDB 447498 / 4.3.2 (2) when standalone SAR test exclusion applies to an antenna that transmits simultaneously with other antennas, the standalone SAR must be estimated according to following to determine simultaneous transmission SAR test exclusion:
  - $(\text{max. power of channel, including tune-up tolerance, mW}) / (\text{min. test separation distance, mm}) \cdot \sqrt{f \text{ (GHz)}} / x$  W/kg for test separation distances  $\leq 50$  mm;  
Where  $x = 7.5$  for 1-g SAR, and  $x = 18.75$  for 10-g SAR.
  - 0.4W/Kg for 1-g SAR and 1.0W/Kg for 10-g SAR, when the separation distance is >50mm.

		Maximum Average Power		Antenna to user (mm)	SAR exclusion threshold (mW)	SAR testing required (Yes/No)	Head (0mm gap)	Body (5mm gap)
		dBm	mW					
BT	Head	-2.66	0.542	5	10	NO	0.023	0.023
	Body			5	10	NO	W/kg	W/kg
WIFI	Head	9.26	8.433	5	10	NO	0.351	0.351
	Body			5	10	NO	W/kg	W/kg

**Maximum test results (WWAN) with BT and WIFI/ HOTSPOT SAR:**

**BT:** Head (0 cm gap): 0.023 W/kg and Body (1.5 cm gap): 0.023 W/kg  
**WIFI:** Head (0 cm gap): 0.351 W/kg and Body (1.5 cm gap): 0.351 W/kg  
**HOTSPOT:** Head (0 cm gap):0.167W/kg and Body (1.0 cm gap): 0.135 W/kg

**HOTSPOT**

<b>Position</b>	<b>Conditions (SAR1+SAR2)</b>	<b>Position</b>	<b>Max. SAR1</b>	<b>Max. SAR2</b>	<b>SAR Summation</b>	<b>Limit (W/kg)</b>
<b>head</b>	<b>GSM835+ Hotspot (voice)</b>	Right Cheek	0.679	0.123	<b>0.802</b>	1.6
	<b>PCS1900+Hotspot (voice)</b>	Right Cheek	0.453	0.123	0.576	1.6
	<b>WCDMA Band II +Hotspot (voice)</b>	Right Cheek	0.826	0.123	0.949	1.6
	<b>WCDMA Band V+ Hotspot (voice)</b>	Right Cheek	1.208	0.123	<b>1.331</b>	1.6
<b>body</b>	<b>GSM835+Hotspot (voice)</b>	Body Back (MS)	0.536	0.135	<b>0.671</b>	1.6
	<b>PCS1900+ Hotspot (voice)</b>	Body Back (MS)	0.407	0.135	0.542	1.6
	<b>WCDMA Band II + Hotspot (voice)</b>	RMC (towards grounds)	0.906	0.135	1.041	1.6
	<b>WCDMA Band V + Hotspot (voice)</b>	RMC (towards grounds)	1.213	0.135	<b>1.348</b>	1.6

## APPENDIX A. SAR SYSTEM VALIDATION DATA

Test Laboratory: AGC Lab

Date: Jan.25,2014

System Check Head 835 MHz

DUT: Dipole 900 MHz Type: SID 900

Communication System CW; Communication System Band: D835 (835.0 MHz); Duty Cycle: 1:1; Conv.F=5.30

Frequency: 835 MHz; Medium parameters used:  $f = 835$  MHz;  $\sigma=0.92$  mho/m;  $\epsilon_r = 41.53$ ;  $\rho= 1000$  kg/m<sup>3</sup> ;

Phantom section: Flat Section; Input Power=10dBm

Ambient temperature (°C): 21, Liquid temperature (°C): 21

SATIMO Configuration:

- Probe: EP165; Calibrated: 01/31/2013
- Sensor-Surface: 4mm (Mechanical Surface Detection)
- Phantom: Flat Phantom; Type: Elliptical Phantom
- Measurement SW: OpenSAR V4\_02\_01

Configuration/System Check GSM 835 Head/Area Scan: Measurement grid: dx=8mm, dy=8mm

Configuration/System Check GSM 835 Head/Zoom Scan: Measurement grid: dx=8mm, dy=8mm, dz=5mm

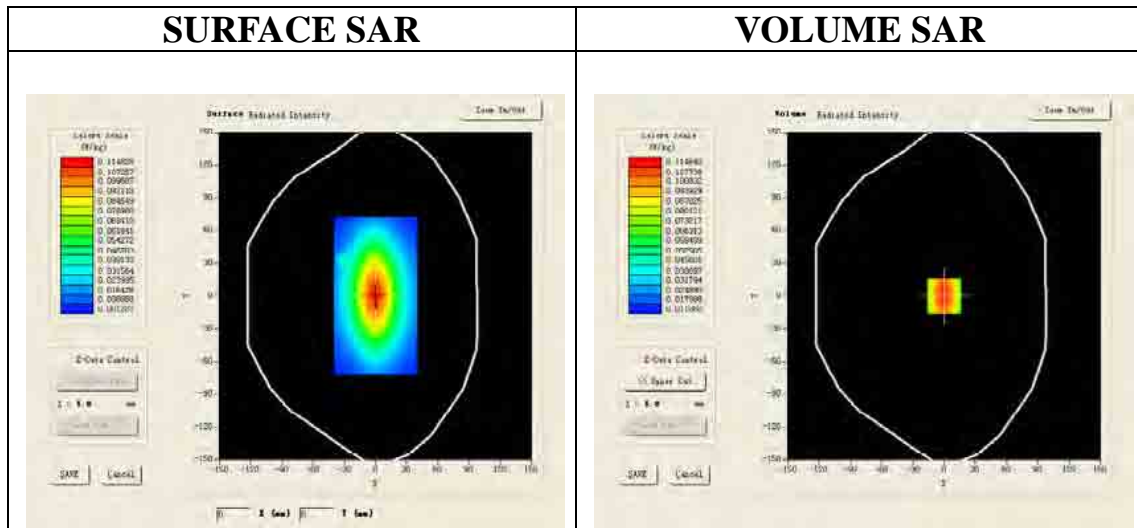

Maximum location: X=0.00, Y=0.00

<b>SAR 10g (W/Kg)</b>	0.067514
<b>SAR 1g (W/Kg)</b>	0.103152

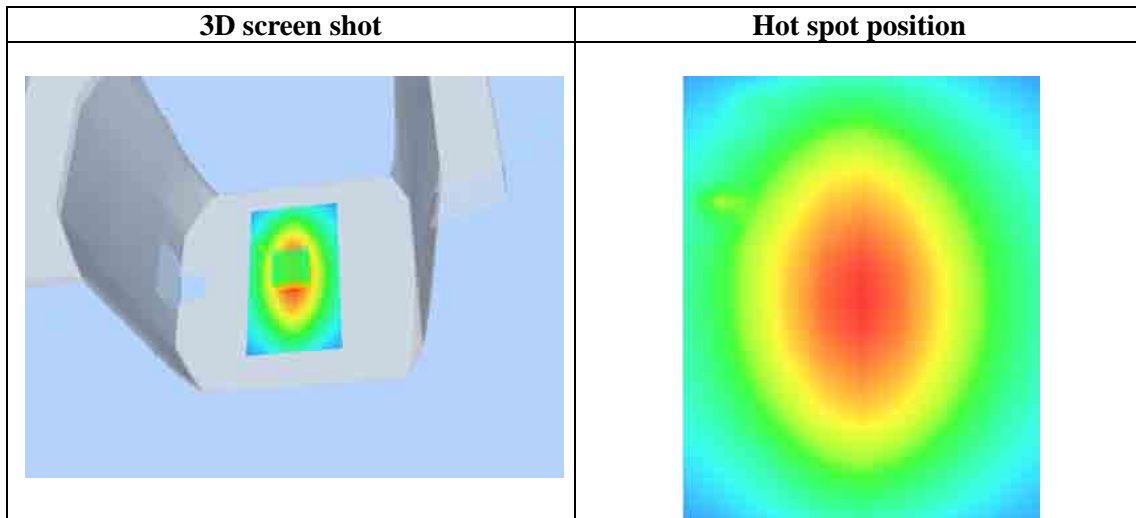
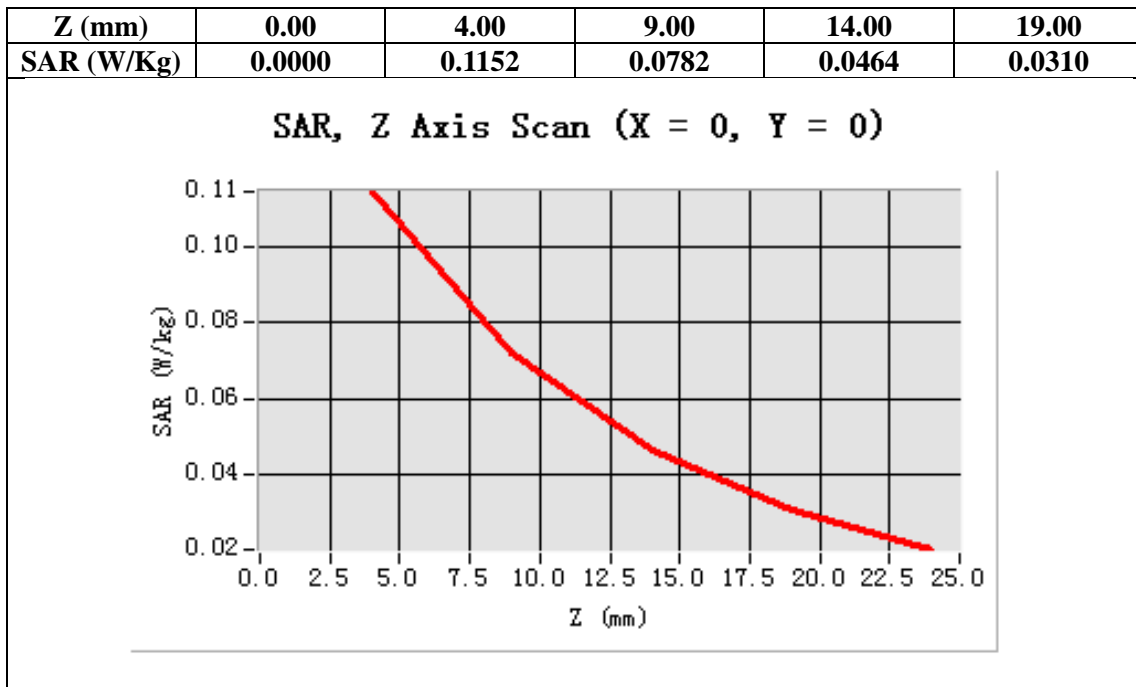

**Test Laboratory: AGC Lab**  
**System Check Head 1900MHz**  
**DUT: Dipole 1900 MHz; Type: SID 1900**

**Date: Jan.25,2014**

Communication System: CW; Communication System Band: D1900 (1900.0 MHz); Duty Cycle:1:1; Conv.F=4.72  
Frequency: 1900 MHz; Medium parameters used:  $f = 1900$  MHz;  $\sigma=1.4$  mho/m;  $\epsilon_r=39.28$ ;  $\rho= 1000$  kg/m<sup>3</sup> ;  
Phantom section: Flat Section; Input Power=10dBm  
Ambient temperature (°C): 21, Liquid temperature (°C): 21

SATIMO Configuration:

- Probe: EP165; Calibrated: 01/31/2013
- Sensor-Surface: 4mm (Mechanical Surface Detection)
- Phantom: Flat Phantom; Type: Elliptical Phantom
- Measurement SW: OpenSAR V4\_02\_01

**Configuration/System Check PCS1900 Head/Area Scan: Measurement grid: dx=8mm,dy=8mm**

**Configuration/System Check PCS1900 Head/Zoom Scan: Measurement grid: dx=8mm, dy=8mm, dz=5mm**

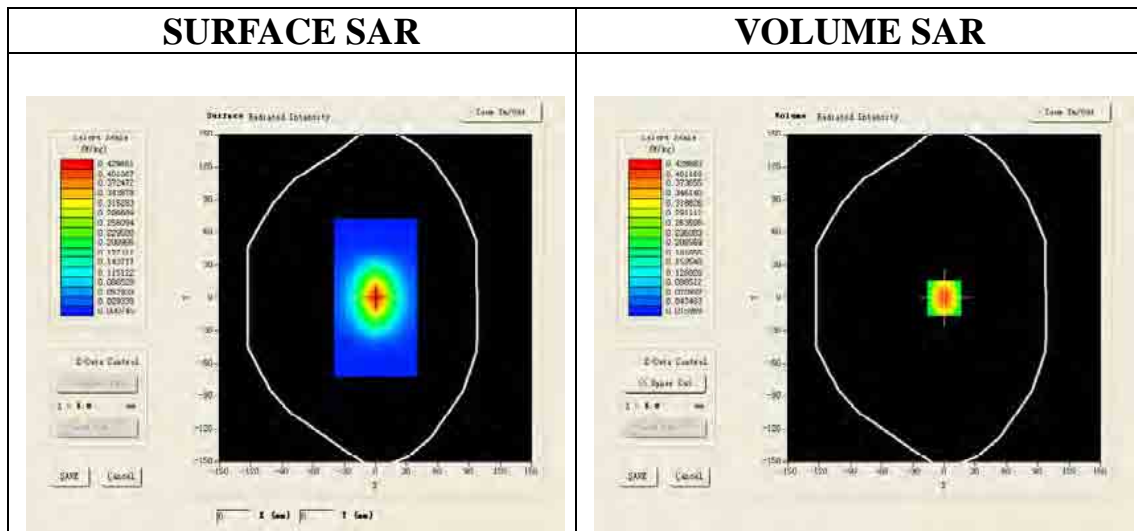

**Maximum location: X=0.00, Y=0.00**

<b>SAR 10g (W/Kg)</b>	0.206623
<b>SAR 1g (W/Kg)</b>	0.398439

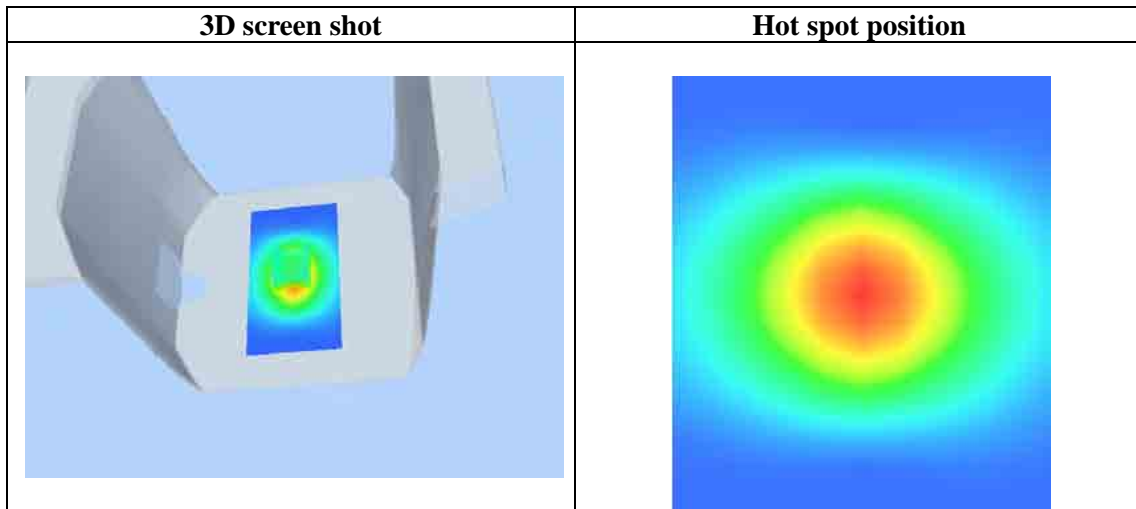
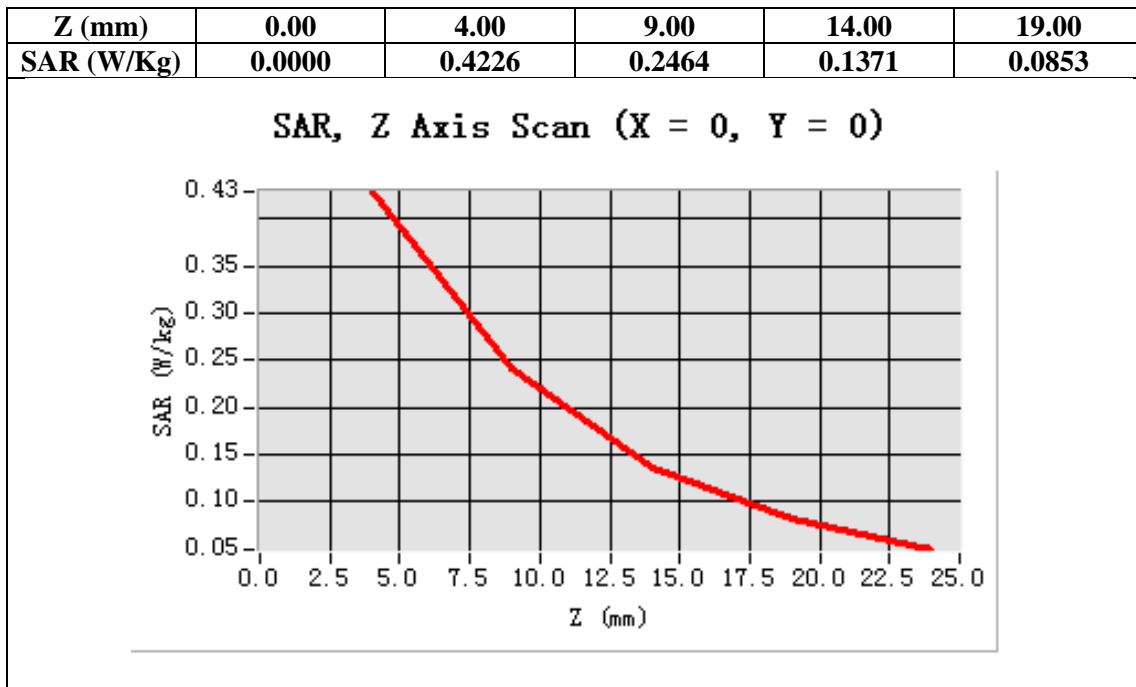

**Test Laboratory: AGC Lab**  
**System Check Head 2450 MHz**  
**DUT: Dipole 2450 MHz Type: SID 2450**

**Date: Jan.25,2014**

Communication System: CW; Communication System Band: D2450 (2450.0 MHz); Duty Cycle: 1:1; Conv.F=4.19  
Frequency: 2450 MHz; Medium parameters used:  $f = 2450$  MHz;  $\sigma = 1.83$  mho/m;  $\epsilon_r = 39.2$ ;  $\rho = 1000$  kg/m<sup>3</sup> ;  
Phantom section: Flat Section; Input Power=10dBm  
Ambient temperature (°C): 21, Liquid temperature (°C): 21

SATIMO Configuration:

- Probe: EP165; Calibrated: 01/31/2013
- Sensor-Surface: 4mm (Mechanical Surface Detection)
- Phantom: Flat Phantom; Type: Elliptical Phantom
- Measurement SW: OpenSAR V4\_02\_01

**Configuration/System Check 2450 MHz Head/Area Scan: Measurement grid: dx=8mm,dy=8mm**

**Configuration/System Check 2450 MHz Head/Zoom Scan: Measurement grid: dx=8mm, dy=8mm, dz=5mm**

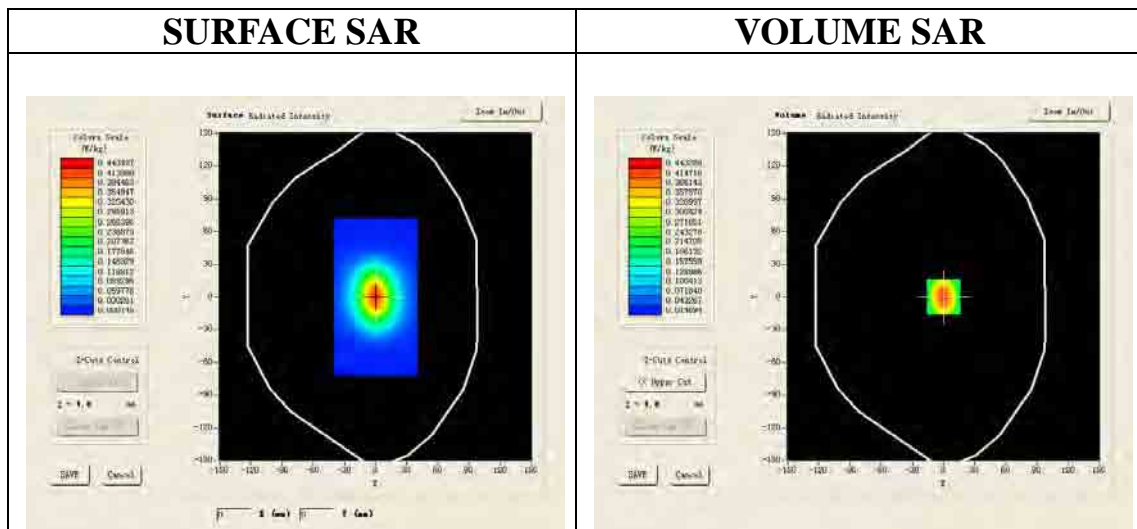

**Maximum location: X=0.00, Y=0.00**

<b>SAR 10g (W/Kg)</b>	0.234761
<b>SAR 1g (W/Kg)</b>	0.495316

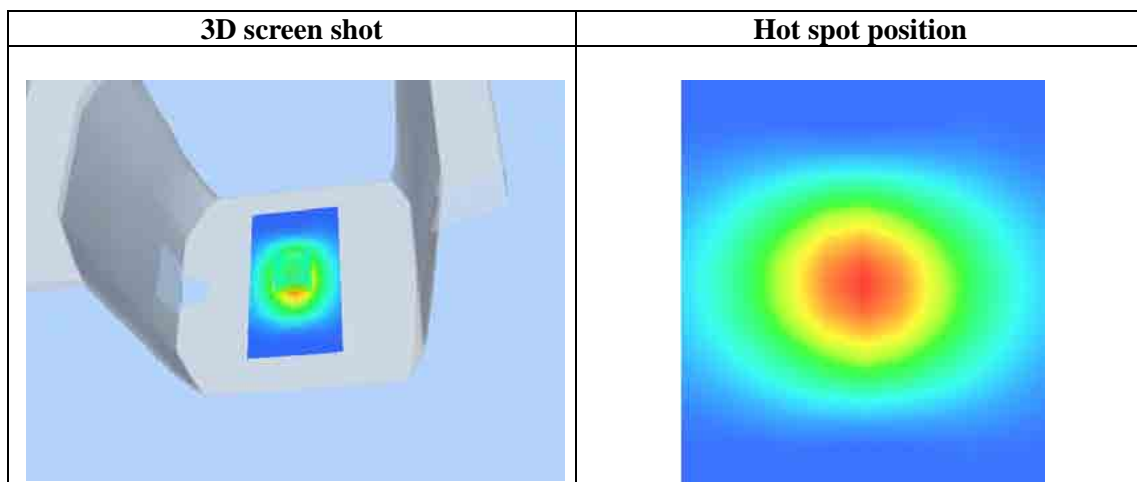
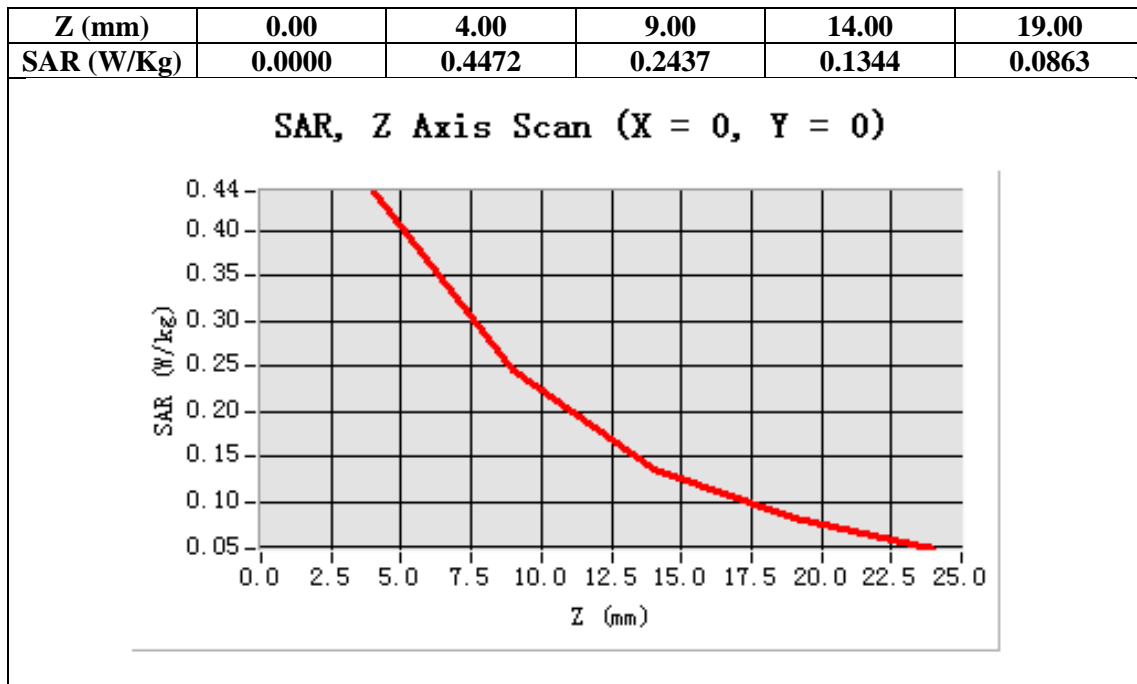



## APPENDIX B. SAR MEASUREMENT DATA

Test Laboratory: AGC Lab  
GSM 835 Mid-Touch-Left <SIM 1>  
DUT: Axe II 3G; Type: Z402

Date: Jan.25,2014

Communication System: Generic GSM; Communication System Band: GSM 835; Duty Cycle: 1:8.3; Conv.F=5.30  
Frequency: 836.6 MHz; Medium parameters used:  $f = 835$  MHz;  $\sigma=0.92$  mho/m;  $\epsilon_r = 41.53$ ;  $\rho = 1000$  kg/m<sup>3</sup> ;  
Phantom section: Left Section  
Ambient temperature (°C): 21.0, Liquid temperature (°C): 21.0

SATIMO Configuration:

- Probe: EP165; Calibrated: 01/31/2013
- Sensor-Surface: 4mm (Mechanical Surface Detection)
- Phantom: Flat Phantom; Type: Elliptical Phantom
- Measurement SW: OpenSAR V4\_02\_01

Configuration/GSM 835 Mid-Touch-Left/Area Scan (6x8x1): Measurement grid: dx=8mm, dy=8mm  
Configuration/GSM 835 Mid-Touch-Left/Zoom Scan (5x5x7)/Cube 0: Measurement grid: dx=8mm, dy=8mm, dz=5mm

Area Scan	sam_direct_droit2_surf8mm.txt
ZoomScan	5x5x7,dx=8mm dy=8mm dz=5mm,Very fast
Phantom	Left head
Device Position	Cheek
Band	GSM 835
Channels	Middle
Signal	TDMA (Crest factor: 8.0)

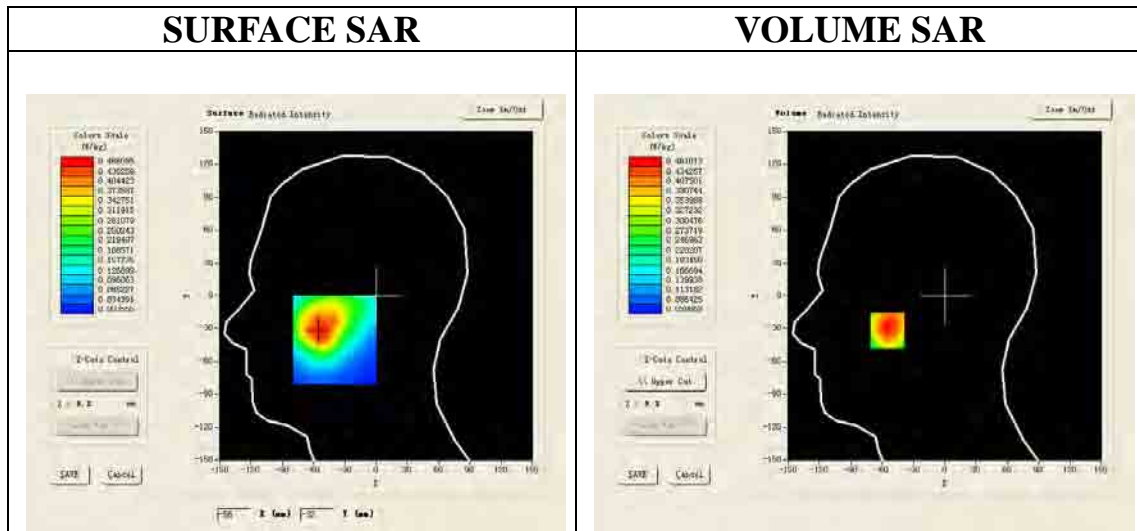

Maximum location: X=-55.00, Y=-32.00

SAR 10g (W/Kg)	0.321468
SAR 1g (W/Kg)	0.445752

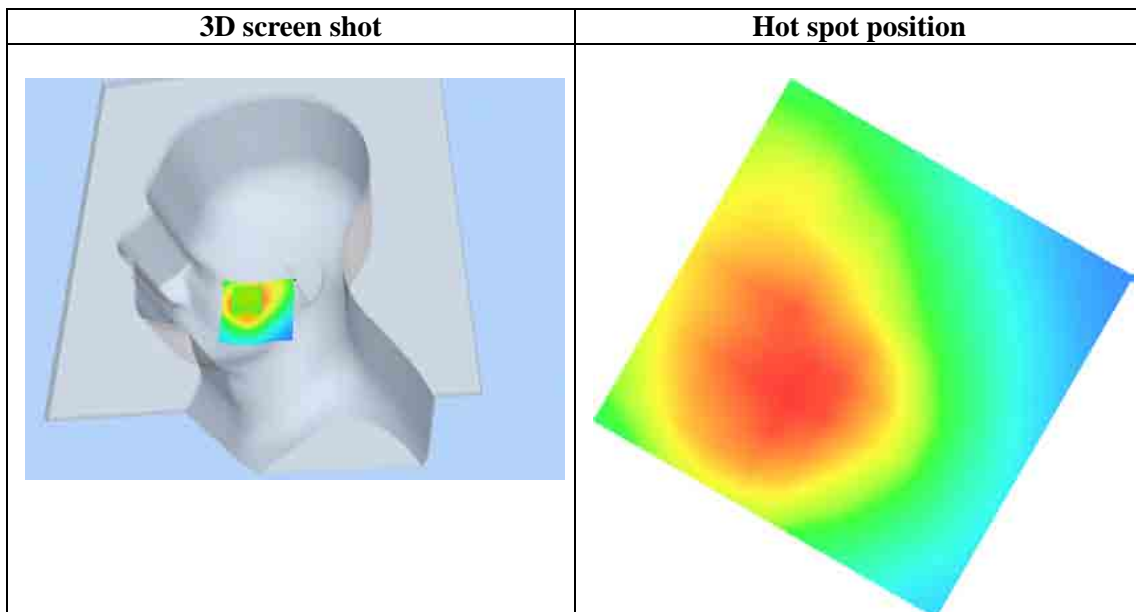
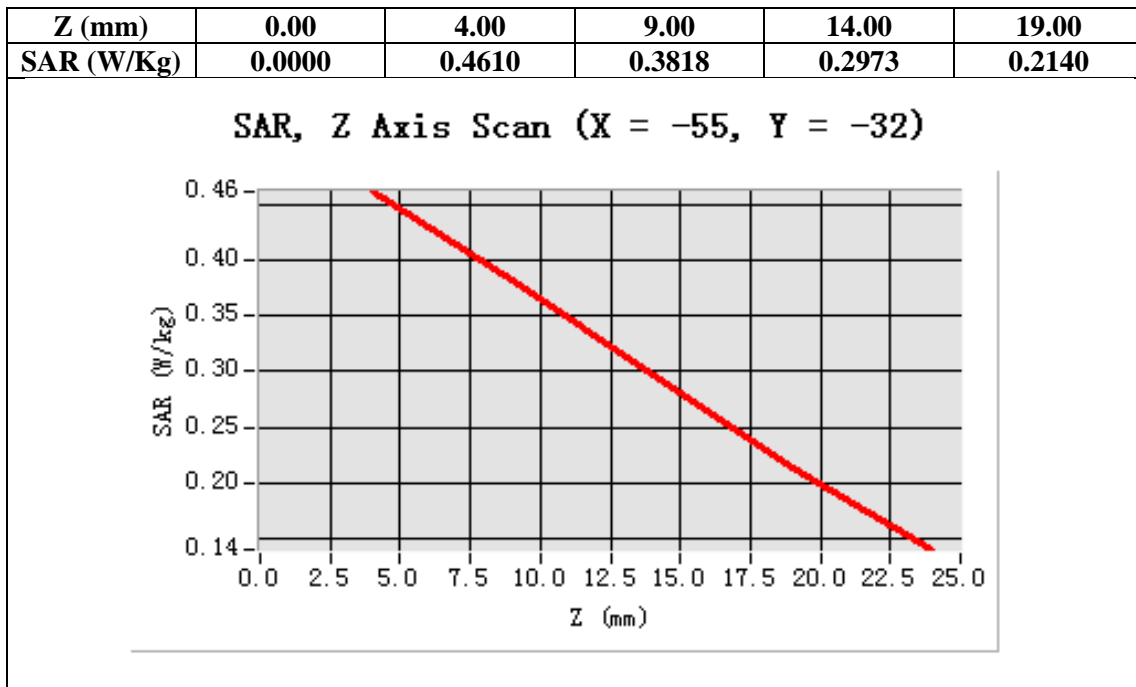

Test Laboratory: AGC Lab  
GSM 835 Mid-Tilt-Left <SIM 1>  
DUT: Axe II 3G; Type: Z402

Date: Jan.25,2014

Communication System: Generic GSM; Communication System Band: GSM 835; Duty Cycle: 1:8.3; Conv.F=5.30;  
Frequency: 836.6 MHz; Medium parameters used: f = 835 MHz;  $\sigma=0.92$  mho/m;  $\epsilon_r=41.53$  ;  $\rho= 1000$  kg/m<sup>3</sup> ;  
Phantom section: Left Section  
Ambient temperature (°C): 21.0, Liquid temperature(°C): 21.0

SATIMO Configuration:

- Probe: EP165; Calibrated: 01/31/2013
- Sensor-Surface: 4mm (Mechanical Surface Detection)
- Phantom: Flat Phantom; Type: Elliptical Phantom
- Measurement SW: OpenSAR V4\_02\_01

Configuration/GSM 835 Mid-Tilt-Left/Area Scan (6x8x1): Measurement grid: dx=8mm, dy=8mm  
Configuration/GSM 835 Mid-Tilt-Left/Zoom Scan (5x5x7)/Cube 0: Measurement grid: dx=8mm, dy=8mm,dz=5mm;

Area Scan	sam_direct_droit2_surf8mm.txt
ZoomScan	5x5x7,dx=8mm dy=8mm dz=5mm,Very fast
Phantom	Left head
Device Position	Tilt
Band	GSM 835
Channels	Middle
Signal	TDMA (Crest factor: 8.0)

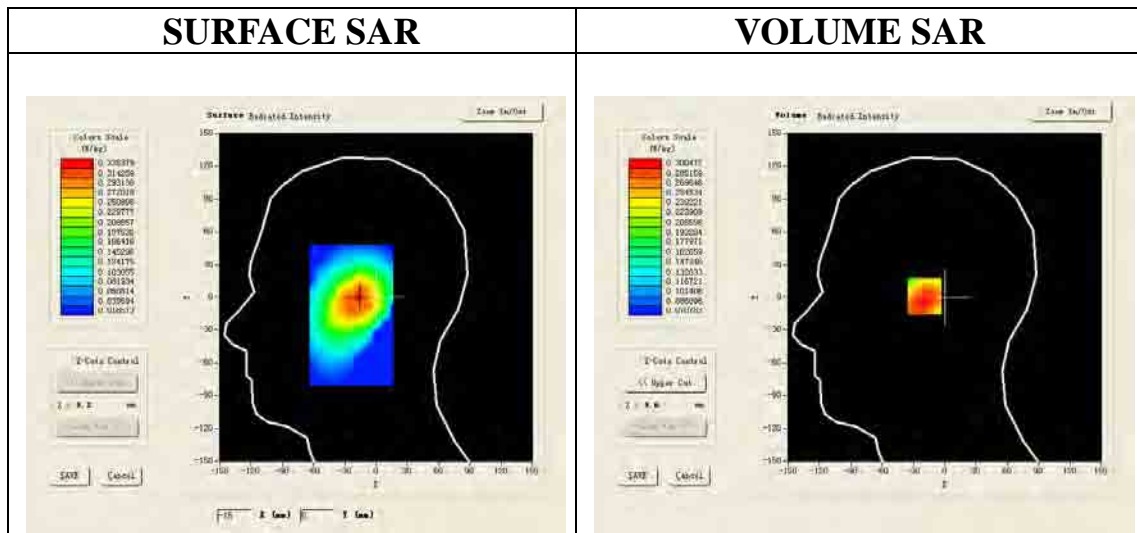

Maximum location: X=-17.00, Y=1.00

SAR 10g (W/Kg)	0.226932
SAR 1g (W/Kg)	0.293641

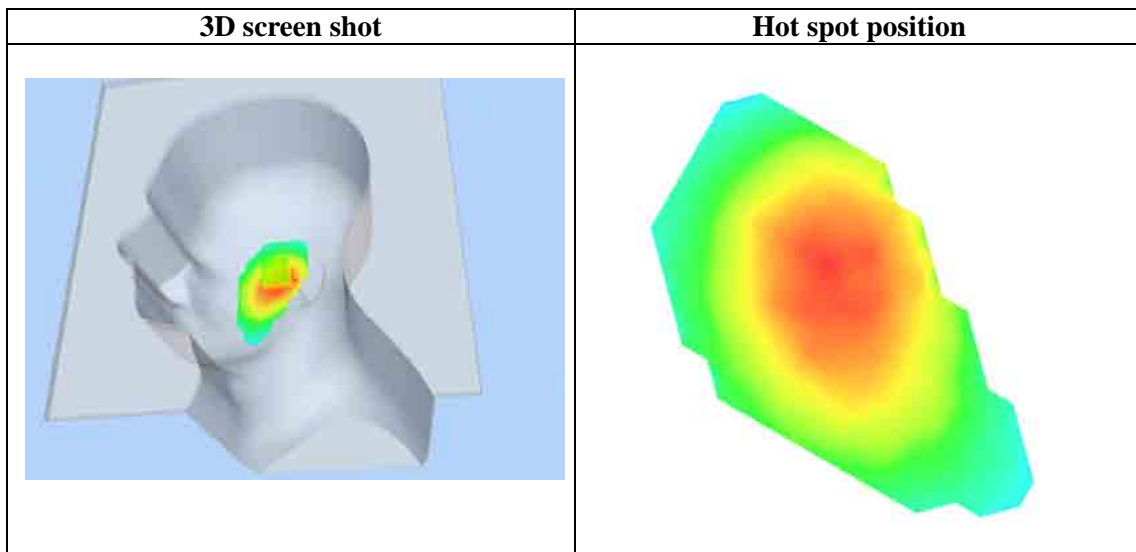
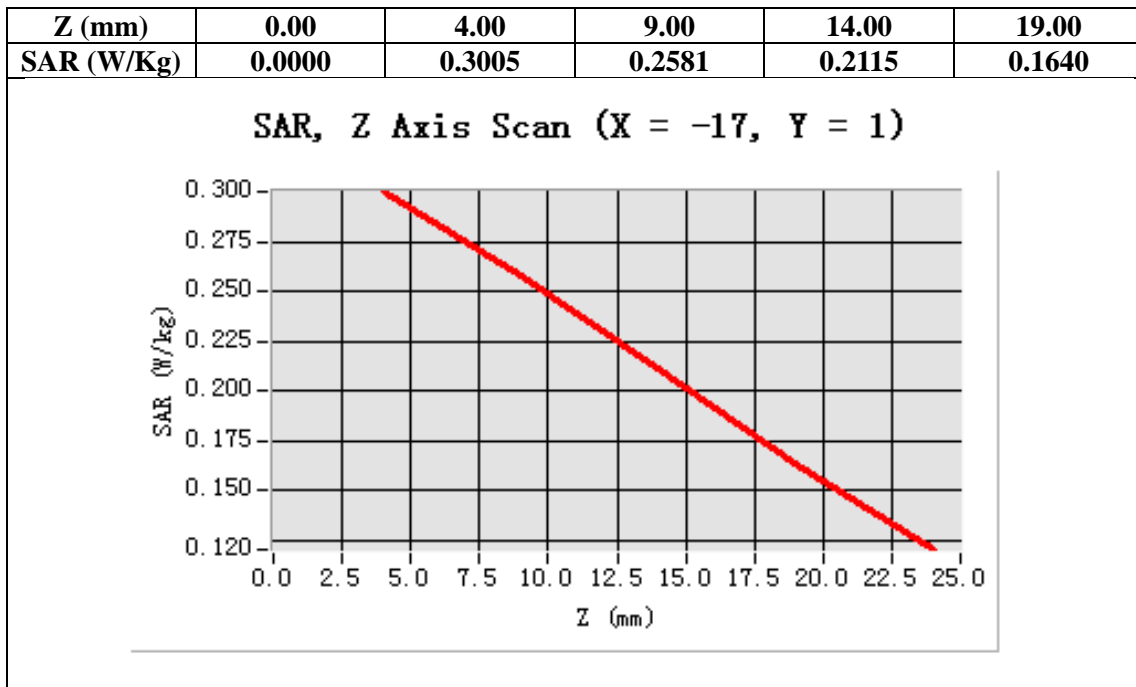

Test Laboratory: AGC Lab  
GSM 835 Mid-Touch-Right <SIM 1>  
DUT: Axe II 3G; Type: Z402

Date: Jan.25,2014

Communication System: Generic GSM; Communication System Band: GSM 835; Duty Cycle: 1:8.3; Conv.F=5.30;  
Frequency: 836.6 MHz; Medium parameters used:  $f = 835$  MHz;  $\sigma = 0.92$  mho/m;  $\epsilon_r = 41.53$ ;  $\rho = 1000$  kg/m<sup>3</sup> ;  
Phantom section: Right Section  
Ambient temperature (°C): 21.0, Liquid temperature (°C): 21.0

SATIMO Configuration:

- Probe: EP165; Calibrated: 01/31/2013
- Sensor-Surface: 4mm (Mechanical Surface Detection)
- Phantom: Flat Phantom; Type: Elliptical Phantom
- Measurement SW: OpenSAR V4\_02\_01

Configuration/GSM 835 Mid-Touch-Right/Area Scan: Measurement grid: dx=8mm, dy=8mm  
Configuration/GSM 835 Mid-Touch-Right/Zoom Scan: Measurement grid: dx=8mm, dy=8mm, dz=5mm;

<b>Area Scan</b>	sam_direct_droit2_surf8mm.txt
<b>ZoomScan</b>	5x5x7,dx=8mm dy=8mm dz=5mm,Very fast
<b>Phantom</b>	Right head
<b>Device Position</b>	Cheek
<b>Band</b>	GSM 835
<b>Channels</b>	Middle
<b>Signal</b>	TDMA (Crest factor: 8.0)

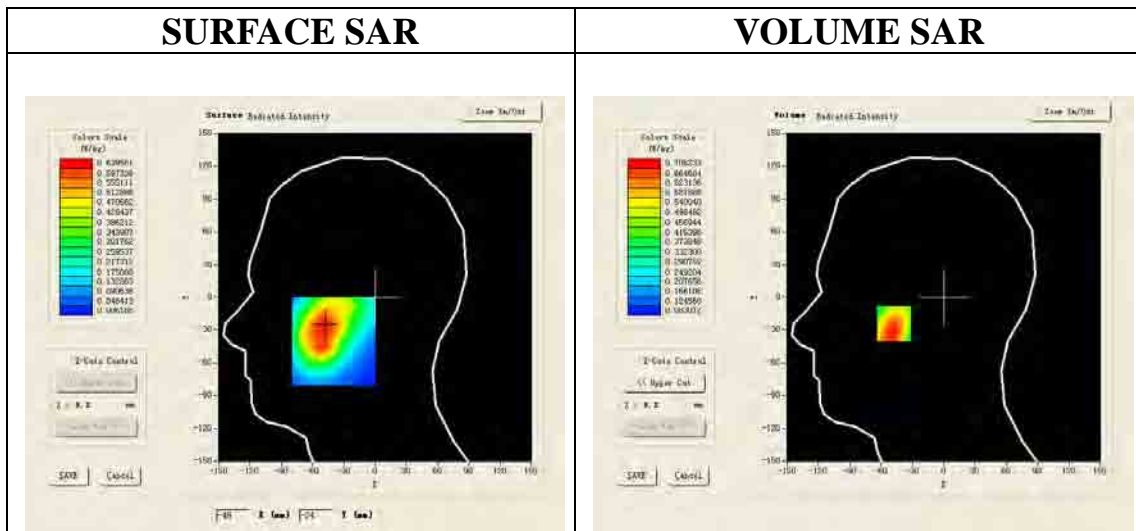

Maximum location: X=-48.00, Y=-24.00

<b>SAR 10g (W/Kg)</b>	0.450183
<b>SAR 1g (W/Kg)</b>	0.678673

Z (mm)	0.00	4.00	9.00	14.00	19.00
SAR (W/Kg)	0.0000	0.6870	0.4638	0.3289	0.2504

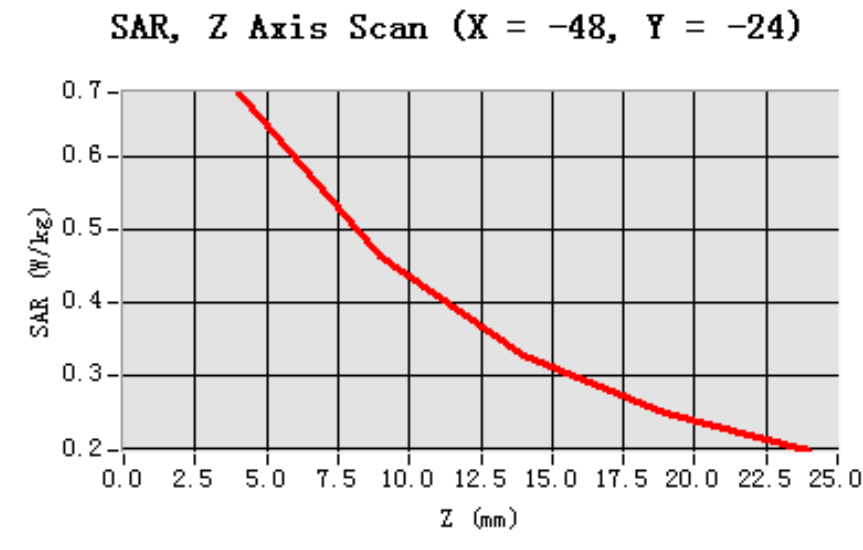

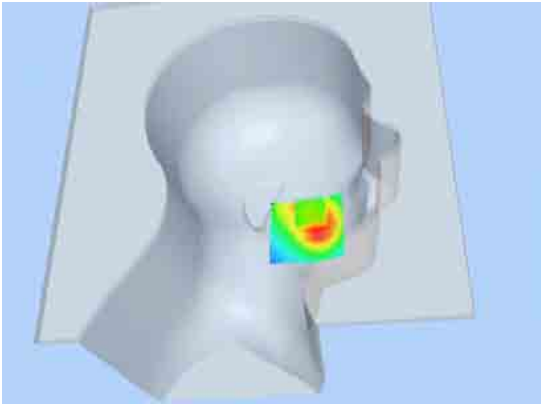
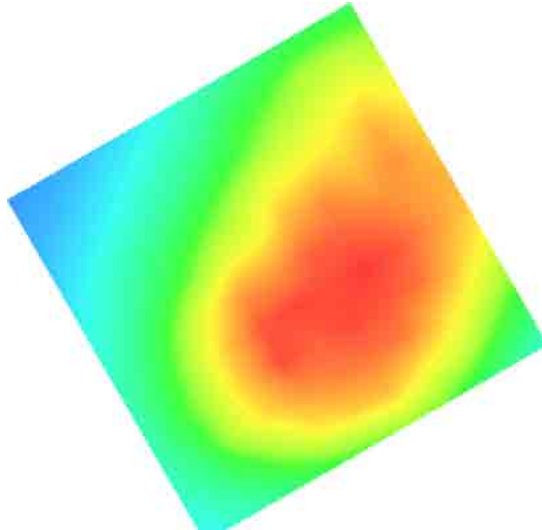
3D screen shot	Hot spot position
	

Test Laboratory: AGC Lab  
GSM 835 Mid-Tilt-Right <SIM 1>  
DUT: Axe II 3G; Type: Z402

Date: Jan.25,2014

Communication System: Generic GSM; Communication System Band: GSM 835; Duty Cycle: 1:8.3; Conv.F=5.30;  
Frequency: 836.6 MHz; Medium parameters used:  $f = 835$  MHz;  $\sigma = 0.92$  mho/m;  $\epsilon_r = 41.53$ ;  $\rho = 1000$  kg/m<sup>3</sup> ;  
Phantom section: Right Section  
Ambient temperature (°C): 21.0, Liquid temperature (°C): 21.0

SATIMO Configuration:

- Probe: EP165; Calibrated: 01/31/2013
- Sensor-Surface: 4mm (Mechanical Surface Detection)
- Phantom: Flat Phantom; Type: Elliptical Phantom
- Measurement SW: OpenSAR V4\_02\_01

Configuration/GSM 835 Mid-Tilt-Right/Area Scan: Measurement grid: dx=8mm, dy=8mm  
Configuration/GSM 835 Mid-Tilt-Right/Zoom Scan: Measurement grid: dx=8mm, dy=8mm, dz=5mm;

Area Scan	sam_direct_droit2_surf8mm.txt
Zoom Scan	5x5x7,dx=8mm dy=8mm dz=5mm,Very fast
Phantom	Right head
Device Position	Tilt
Band	GSM 835
Channels	Middle
Signal	TDMA (Crest factor: 8.0)

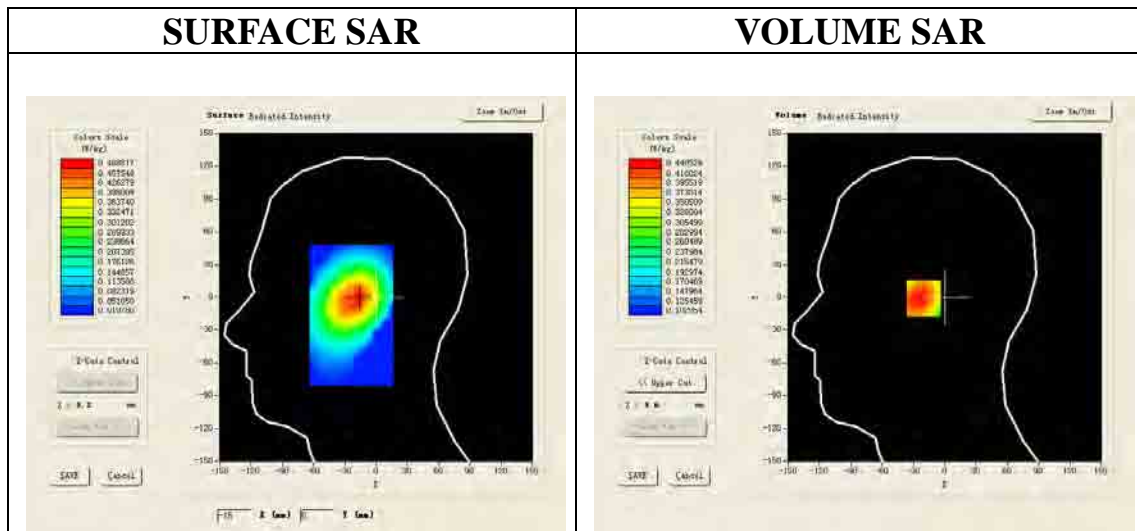

Maximum location: X=-17.00, Y=-1.00

SAR 10g (W/Kg)	0.318430
SAR 1g (W/Kg)	0.429210

Z (mm)	0.00	4.00	9.00	14.00	19.00
SAR (W/Kg)	0.0000	0.4405	0.3338	0.2605	0.2107

**SAR, Z Axis Scan (X = -17, Y = -1)**

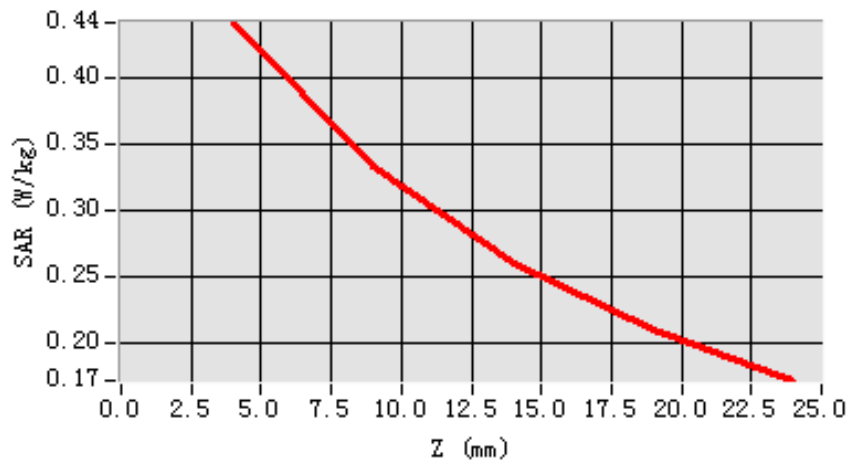

**3D screen shot**

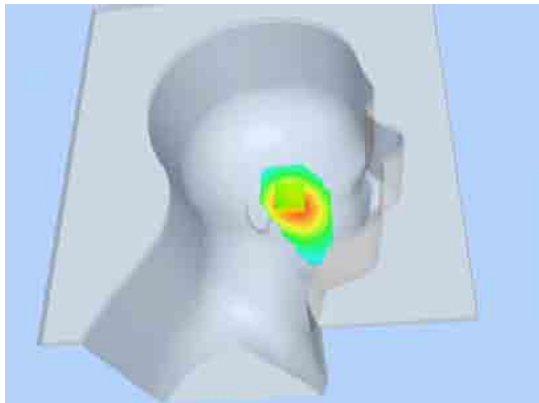

**Hot spot position**

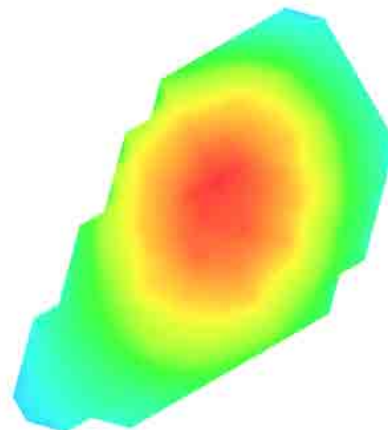



Test Laboratory: AGC Lab  
GSM 835 Mid-Touch-Right <SIM 2>  
DUT: Axe II 3G; Type: Z402

Date: Jan.25,2014

Communication System: Generic GSM; Communication System Band: GSM 835; Duty Cycle: 1:8.3; Conv.F=5.30  
Frequency: 836.6 MHz; Medium parameters used:  $f = 835$  MHz;  $\sigma = 0.92$  mho/m;  $\epsilon_r = 41.53$ ;  $\rho = 1000$  kg/m<sup>3</sup> ;  
Phantom section: Right Section  
Ambient temperature (°C): 21.0, Liquid temperature (°C): 21.0

SATIMO Configuration:

- Probe: EP165; Calibrated: 01/31/2013
- Sensor-Surface: 4mm (Mechanical Surface Detection)
- Phantom: Flat Phantom; Type: Elliptical Phantom
- Measurement SW: OpenSAR V4\_02\_01

Configuration/GSM 835 Mid-Touch-Right/Area Scan (6x8x1): Measurement grid: dx=8mm, dy=8mm  
Configuration/GSM 835 Mid-Touch-Right/Zoom Scan (5x5x7)/Cube 0: Measurement grid: dx=8mm, dy=8mm, dz=5mm

<b>Area Scan</b>	sam_direct_droit2_surf8mm.txt
<b>ZoomScan</b>	5x5x7,dx=8mm dy=8mm dz=5mm,Very fast
<b>Phantom</b>	Right head
<b>Device Position</b>	Cheek
<b>Band</b>	GSM 835
<b>Channels</b>	Middle
<b>Signal</b>	TDMA (Crest factor: 8.0)

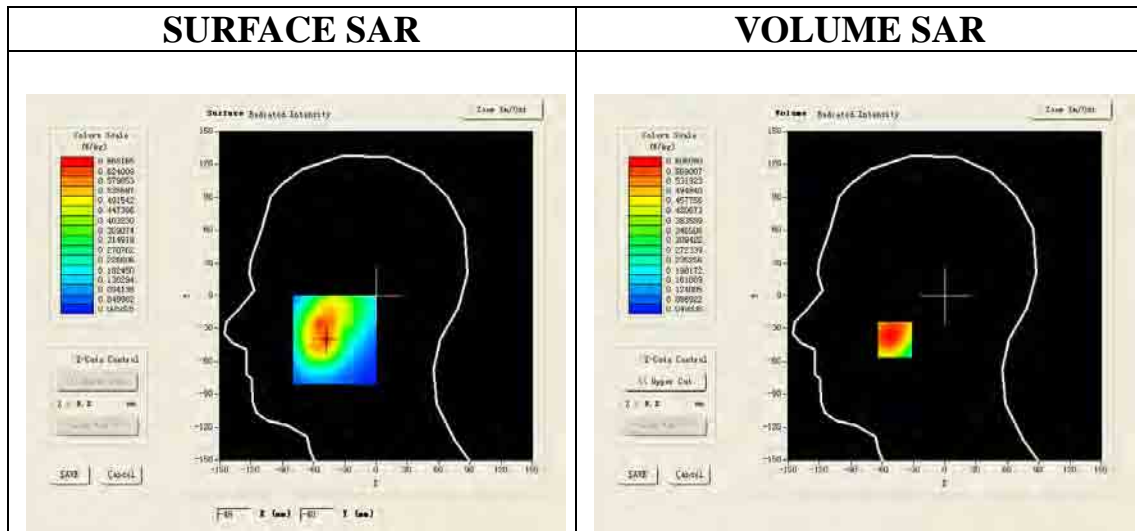

**Maximum location: X=-48.00, Y=-40.00**

<b>SAR 10g (W/Kg)</b>	0.400819
<b>SAR 1g (W/Kg)</b>	0.592177

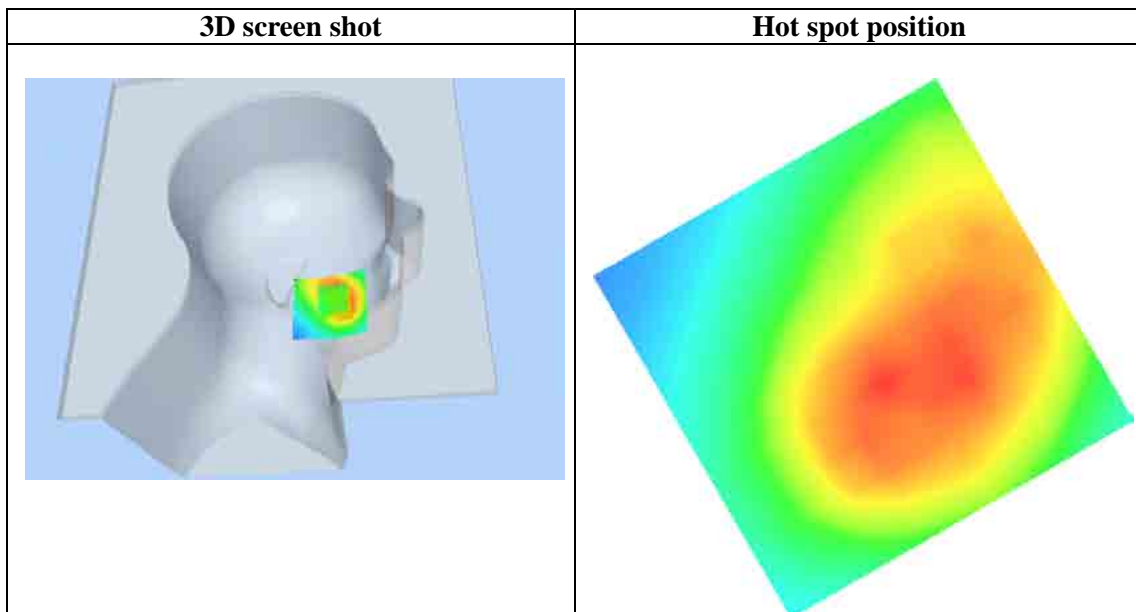
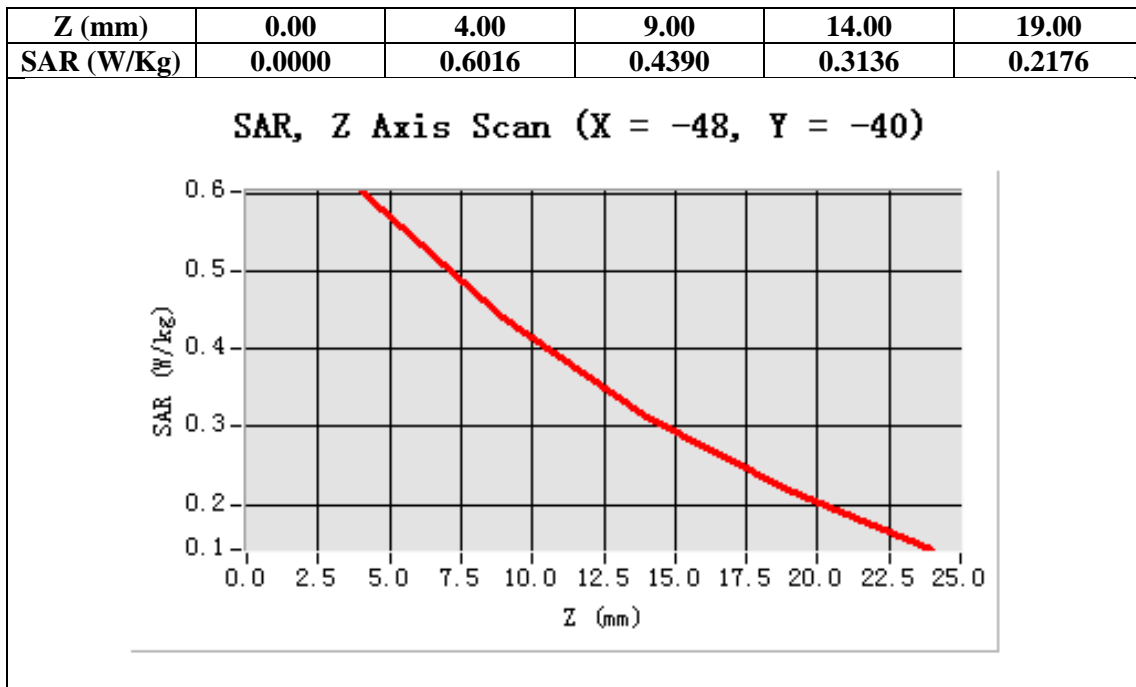

Test Laboratory: AGC Lab  
GSM 835 Mid- Body- Back <SIM 1>  
DUT: Axe II 3G; Type: Z402

Date: Jan.25,2014

Communication System: Generic GSM; Communication System Band: GSM 835; Duty Cycle: 1:8.3; Conv.F=5.46;  
Frequency: 836.6 MHz; Medium parameters used:  $f = 835$  MHz;  $\sigma = 0.96$  mho/m;  $\epsilon_r = 55.02$ ;  $\rho = 1000$  kg/m<sup>3</sup> ;  
Phantom section: Flat Section  
Ambient temperature (°C): 21.0, Liquid temperature (°C): 21.0

SATIMO Configuration:

- Probe: EP165; Calibrated: 01/31/2013
- Sensor-Surface: 4mm (Mechanical Surface Detection)
- Phantom: Flat Phantom; Type: Elliptical Phantom
- Measurement SW: OpenSAR V4\_02\_01

Configuration/GSM 835 Mid-Body-Back/Area Scan (6x8x1): Measurement grid: dx=8mm, dy=8mm  
Configuration/GSM 835 Mid-Body-Back/Zoom Scan (5x5x7)/Cube 0: Measurement grid: dx=8mm, dy=8mm, dz=5mm;

Area Scan	surf_sam_plan.txt
ZoomScan	5x5x7,dx=8mm dy=8mm dz=5mm,Very fast
Phantom	Validation plane
Device Position	Body Back
Band	GSM 835
Channels	Middle
Signal	TDMA (Crest factor: 8.0)

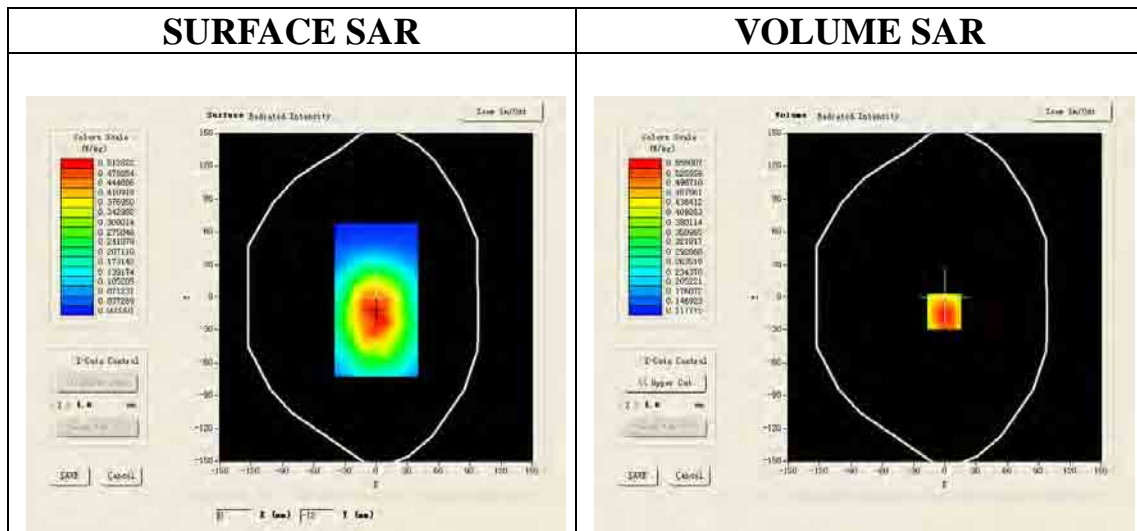

Maximum location: X=-1.00, Y=-13.00

SAR 10g (W/Kg)	0.372820
SAR 1g (W/Kg)	0.535937

Z (mm)	0.00	4.00	9.00	14.00	19.00
SAR (W/Kg)	0.0000	0.5550	0.3856	0.2816	0.2201

**SAR, Z Axis Scan (X = -1, Y = -13)**

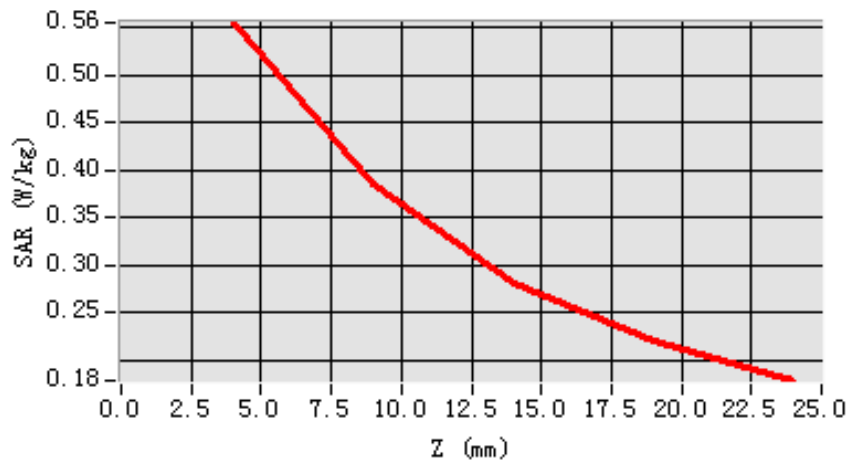

**3D screen shot**

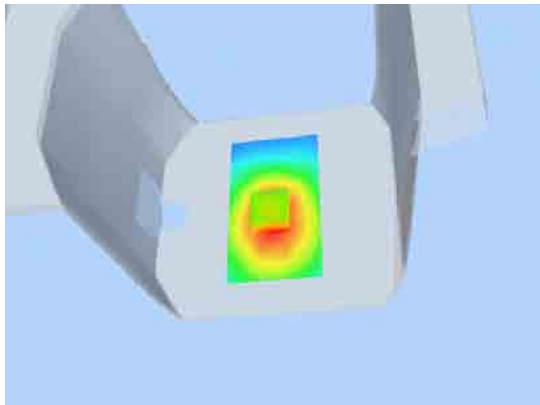

**Hot spot position**

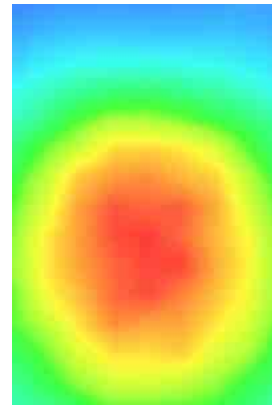

Test Laboratory: AGC Lab  
GSM 835 Mid- Body- Front (MS) <SIM 1>  
DUT: Axe II 3G; Type: Z402

Date: Jan.25,2014

Communication System: Generic GSM; Communication System Band: GSM 835; Duty Cycle: 1:8.3; Conv.F=5.46;  
Frequency: 836.6 MHz; Medium parameters used: f = 835 MHz;  $\sigma = 0.96\text{mho/m}$ ;  $\epsilon_r = 55.02$ ;  $\rho = 1000\text{ kg/m}^3$  ;  
Phantom section: Flat Section  
Ambient temperature (°C): 21.0, Liquid temperature (°C): 21.0

SATIMO Configuration:

- Probe: EP165; Calibrated: 01/31/2013
- Sensor-Surface: 4mm (Mechanical Surface Detection)
- Phantom: Flat Phantom; Type: Elliptical Phantom
- Measurement SW: OpenSAR V4\_02\_01

Configuration/GSM 835 Mid-Body- Front /Area Scan (6x8x1): Measurement grid: dx=8mm, dy=8mm  
Configuration/GSM 835 Mid-Body- Front Zoom Scan (5x5x7)/Cube 0: Measurement grid: dx=8mm, dy=8mm, dz=5mm;

Area Scan	surf_sam_plan.txt
ZoomScan	5x5x7,dx=8mm dy=8mm dz=5mm,Very fast
Phantom	Validation plane
Device Position	Body Front
Band	GSM 835
Channels	Middle
Signal	TDMA (Crest factor: 8.0)

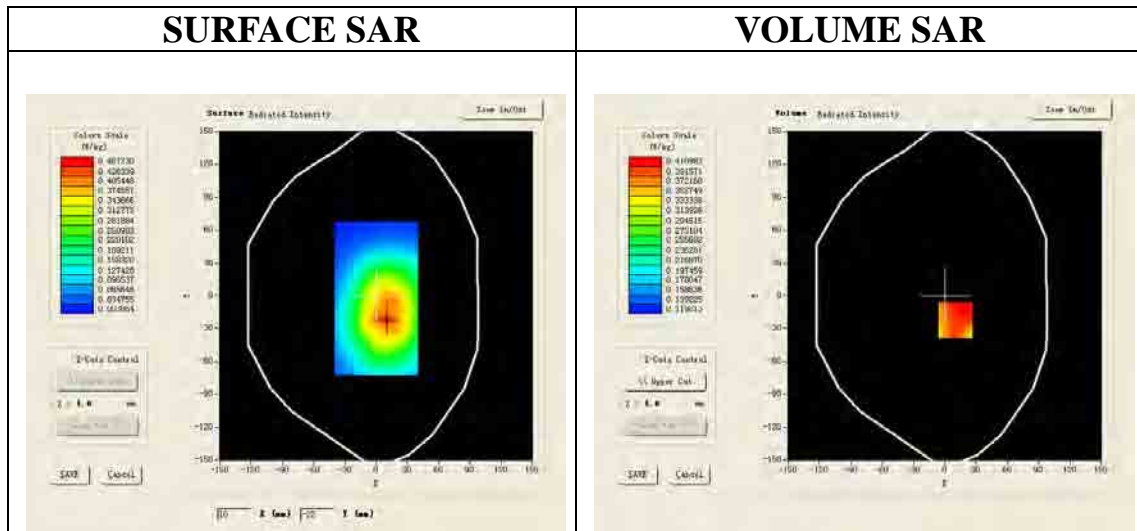

Maximum location: X=10.00, Y=-22.00

SAR 10g (W/Kg)	0.308677
SAR 1g (W/Kg)	0.399159

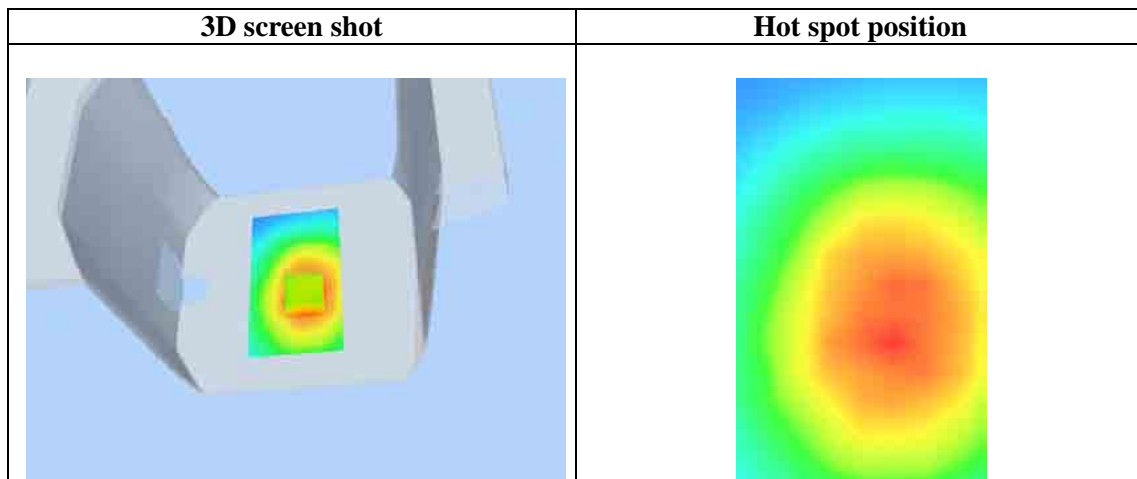
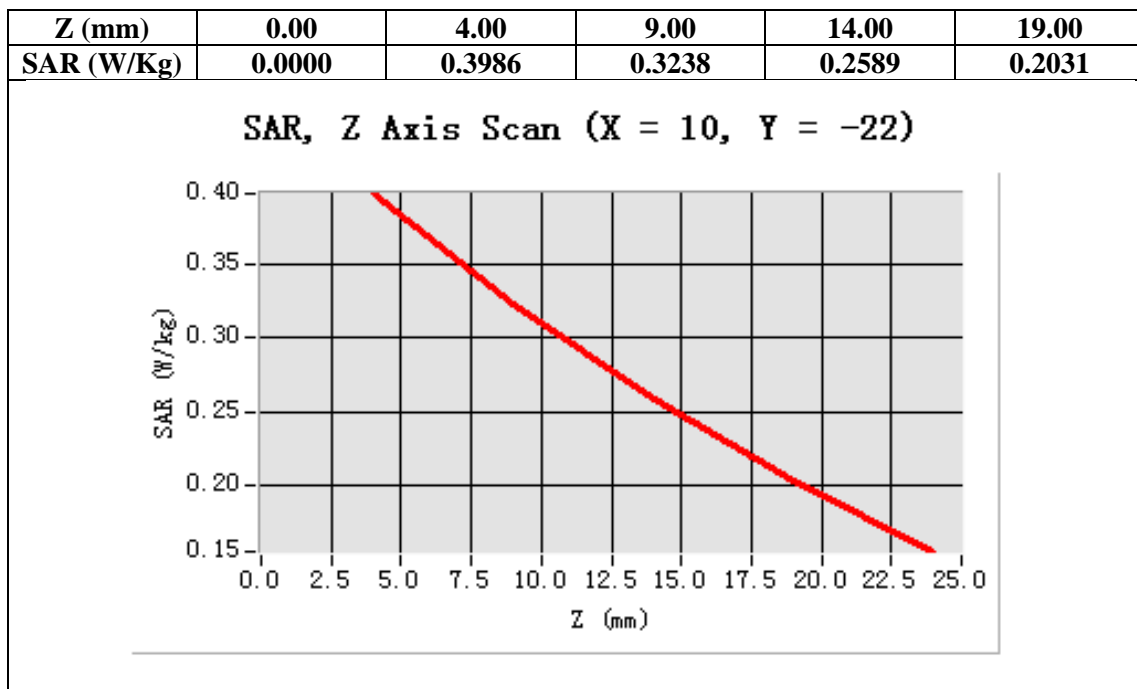

Test Laboratory: AGC Lab  
PCS 1900 Mid-Touch-Left <SIM 1>  
DUT: Axe II 3G; Type: Z402

Date: Jan.25,2014

Communication System: Generic GSM; Communication System Band: PCS 1900; Duty Cycle: 1:8.3; Conv.F=4.72;  
Frequency: 1880 MHz; Medium parameters used:  $f = 1900$  MHz;  $\sigma = 1.4$  mho/m;  $\epsilon_r = 39.28$ ;  $\rho = 1000$  kg/m<sup>3</sup> ;  
Phantom section: Left Section  
Ambient temperature (°C): 21.0, Liquid temperature (°C): 21.0

SATIMO Configuration:

- Probe: EP165; Calibrated: 01/31/2013
- Sensor-Surface: 4mm (Mechanical Surface Detection)
- Phantom: Flat Phantom; Type: Elliptical Phantom
- Measurement SW: OpenSAR V4\_02\_01

Configuration/PCS1900 Mid-Touch-Left/Area Scan: Measurement grid: dx=8mm, dy=8mm  
Configuration/PCS1900 Mid-Touch-Left/Zoom Scan: Measurement grid: dx=8mm,  
dy=8mm, dz=5mm;

Area Scan	sam_direct_droit2_surf8mm.txt
ZoomScan	5x5x7,dx=8mm dy=8mm dz=5mm,Very fast
Phantom	Left head
Device Position	Cheek
Band	PCS 1900
Channels	Middle
Signal	TDMA (Crest factor: 8.0)

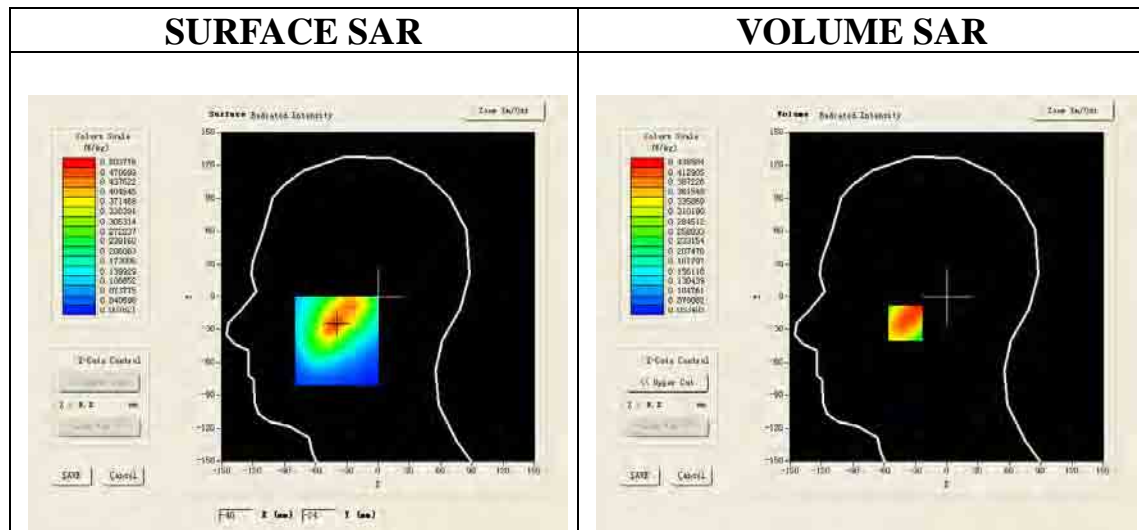

Maximum location: X=-40.00, Y=-24.00

SAR 10g (W/Kg)	0.292379
SAR 1g (W/Kg)	0.415313

Z (mm)	0.00	4.00	9.00	14.00	19.00
SAR (W/Kg)	0.0000	0.4201	0.3318	0.2513	0.1799

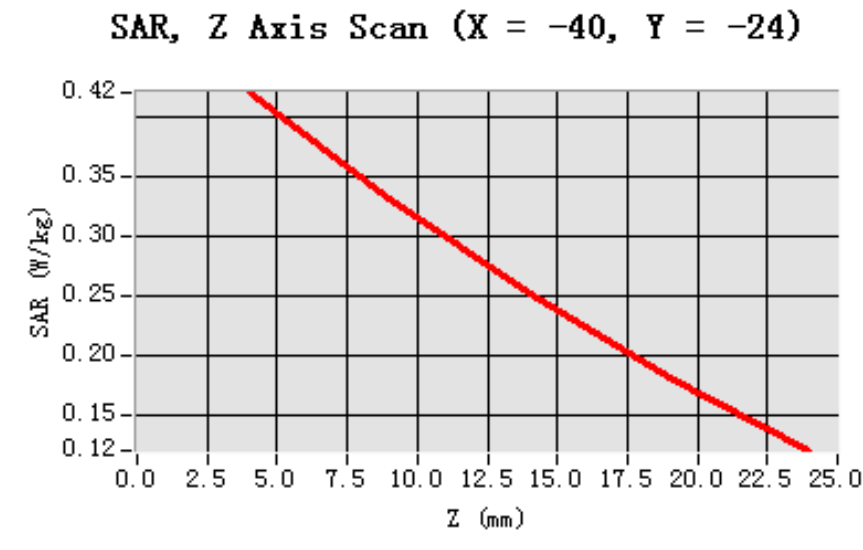

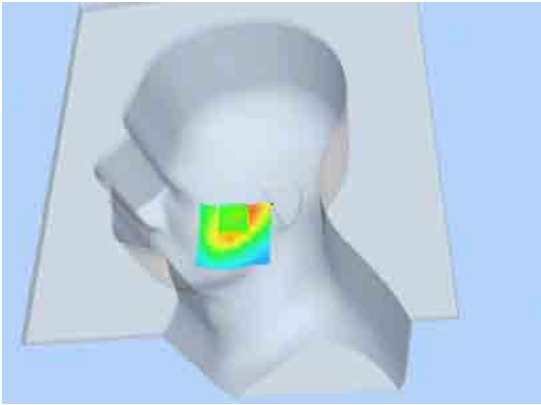
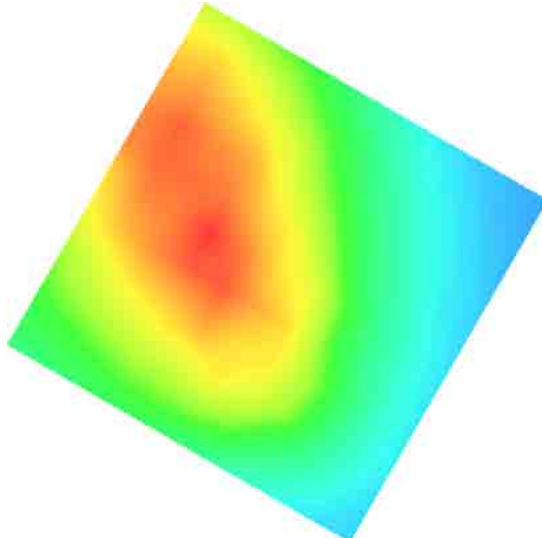
3D screen shot	Hot spot position
	



Test Laboratory: AGC Lab  
PCS 1900 Mid-Tilt-Left <SIM 1>  
DUT: Axe II 3G; Type: Z402

Date: Jan.25,2014

Communication System: Generic GSM; Communication System Band: PCS 1900; Duty Cycle: 1:8.3; Conv.F=4.72;  
Frequency: 1880 MHz; Medium parameters used:  $f = 1900$  MHz;  $\sigma = 1.4$  mho/m;  $\epsilon_r = 39.28$ ;  $\rho = 1000$  kg/m<sup>3</sup> ;  
Phantom section: Left Section  
Ambient temperature (°C): 21.0, Liquid temperature (°C): 21.0

SATIMO Configuration:

- Probe: EP165; Calibrated: 01/31/2013
- Sensor-Surface: 4mm (Mechanical Surface Detection)
- Phantom: Flat Phantom; Type: Elliptical Phantom
- Measurement SW: OpenSAR V4\_02\_01

Configuration/PCS1900 Mid-Tilt-Left/Area Scan: Measurement grid: dx=8mm, dy=8mm  
Configuration/PCS1900 Mid-Tilt-Left/Zoom Scan: Measurement grid: dx=8mm,  
dy=8mm,dz=5mm;

Area Scan	sam_direct_droit2_surf8mm.txt
ZoomScan	5x5x7,dx=8mm dy=8mm dz=5mm,Very fast
Phantom	Left head
Device Position	Tilt
Band	PCS 1900
Channels	Middle
Signal	TDMA (Crest factor: 8.0)

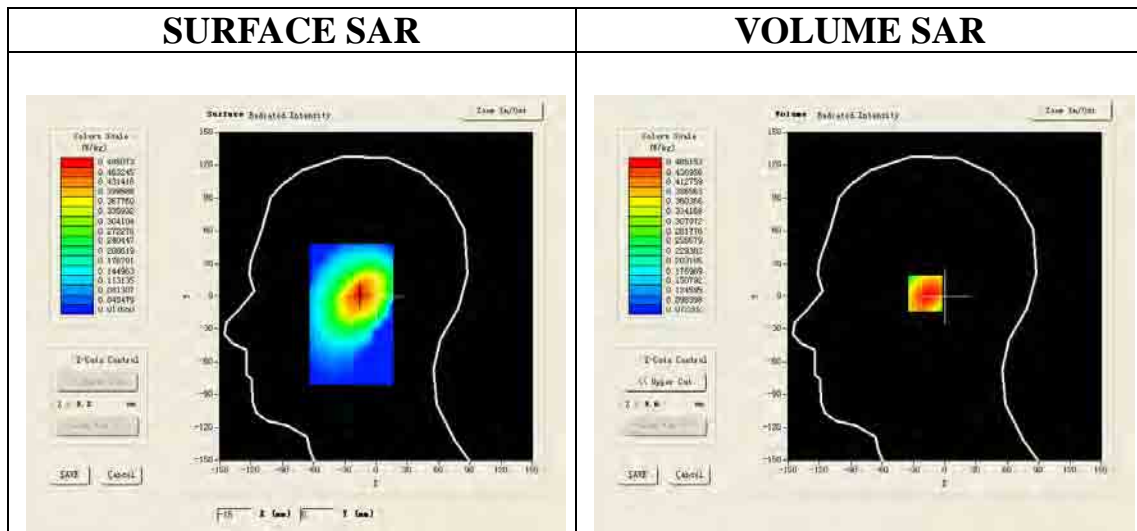

Maximum location: X=-16.00, Y=3.00

SAR 10g (W/Kg)	0.320983
SAR 1g (W/Kg)	0.449313

Z (mm)	0.00	4.00	9.00	14.00	19.00
SAR (W/Kg)	0.0000	0.4652	0.3579	0.2711	0.2013

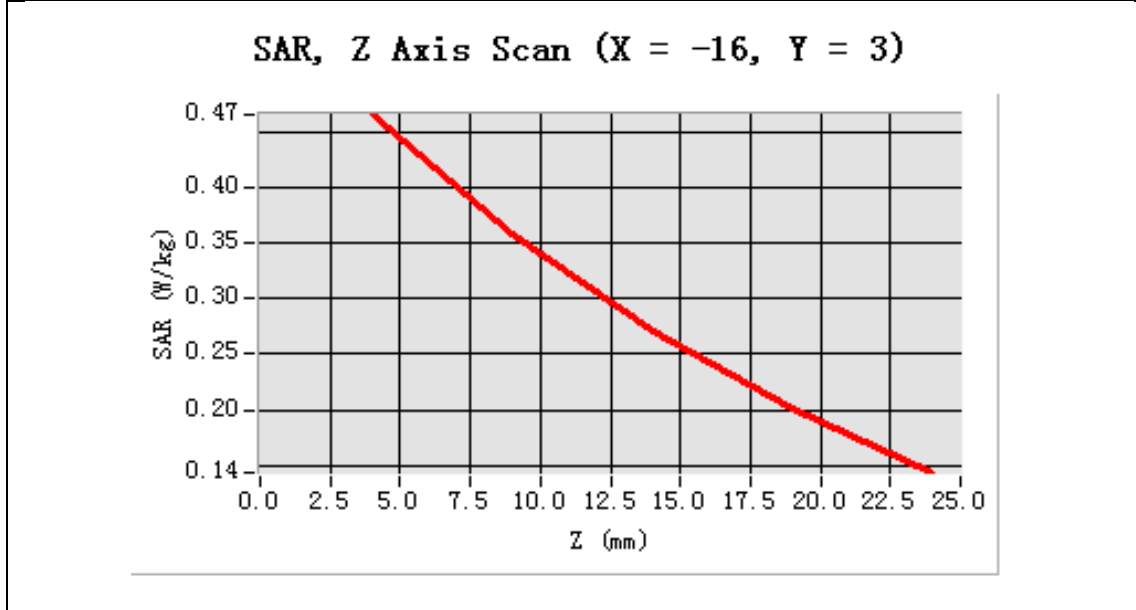

3D screen shot	Hot spot position
<p>A 3D rendering of a human head model. A localized area on the forehead is highlighted with a color gradient from cyan to red, indicating a hot spot of high SAR exposure.</p>	<p>A 2D heatmap showing the spatial distribution of SAR exposure. The highest exposure (red) is concentrated in the forehead region, with exposure decreasing towards the edges (cyan/blue).</p>

Test Laboratory: AGC Lab  
PCS 1900 Mid-Touch-Right <SIM 1>  
DUT: Axe II 3G; Type: Z402

Date: Jan.25,2014

Communication System: Generic GSM; Communication System Band: PCS 1900; Duty Cycle: 1:8.3; Conv.F=4.72;  
Frequency: 1880 MHz; Medium parameters used:  $f = 1900$  MHz;  $\sigma = 1.4$  mho/m;  $\epsilon_r = 39.28$ ;  $\rho = 1000$  kg/m<sup>3</sup> ;  
Phantom section: Right Section  
Ambient temperature (°C): 21.0, Liquid temperature (°C): 21.0

SATIMO Configuration:

- Probe: EP165; Calibrated: 01/31/2013
- Sensor-Surface: 4mm (Mechanical Surface Detection)
- Phantom: Flat Phantom; Type: Elliptical Phantom
- Measurement SW: OpenSAR V4\_02\_01

Configuration/PCS1900 Mid-Touch-Right/Area Scan: Measurement grid: dx=8mm, dy=8mm  
Configuration/PCS1900 Mid-Touch-Right/Zoom Scan: Measurement grid: dx=8mm,  
dy=8mm, dz=5mm;

Area Scan	sam_direct_droit2_surf8mm.txt
ZoomScan	5x5x7,dx=8mm dy=8mm dz=5mm,Very fast
Phantom	Right head
Device Position	Cheek
Band	PCS 1900
Channels	Middle
Signal	TDMA (Crest factor: 8.0)

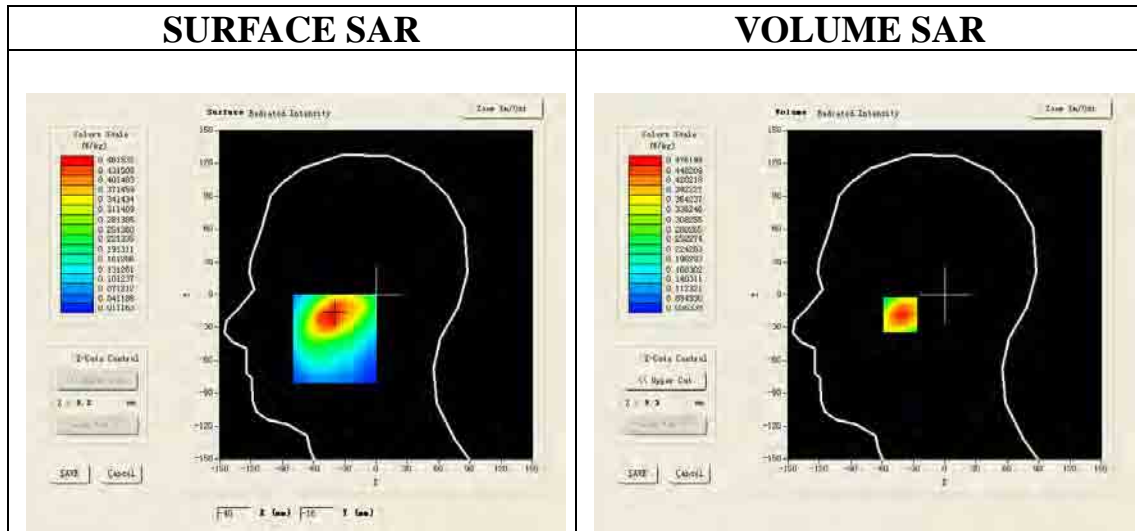

Maximum location: X=-43.00, Y=-18.00

SAR 10g (W/Kg)	0.304164
SAR 1g (W/Kg)	0.452671

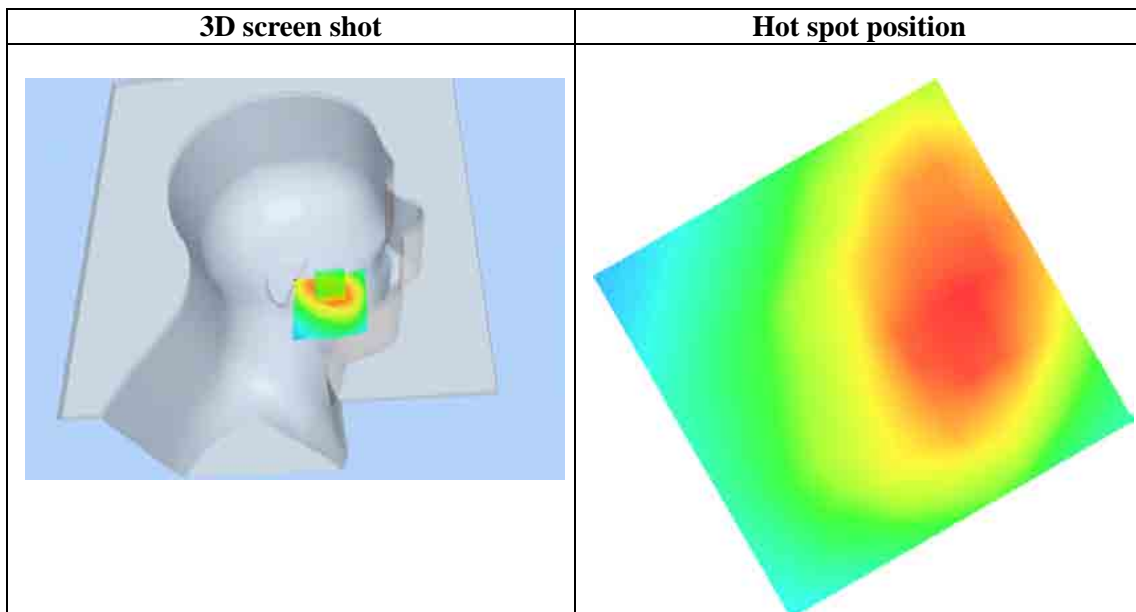
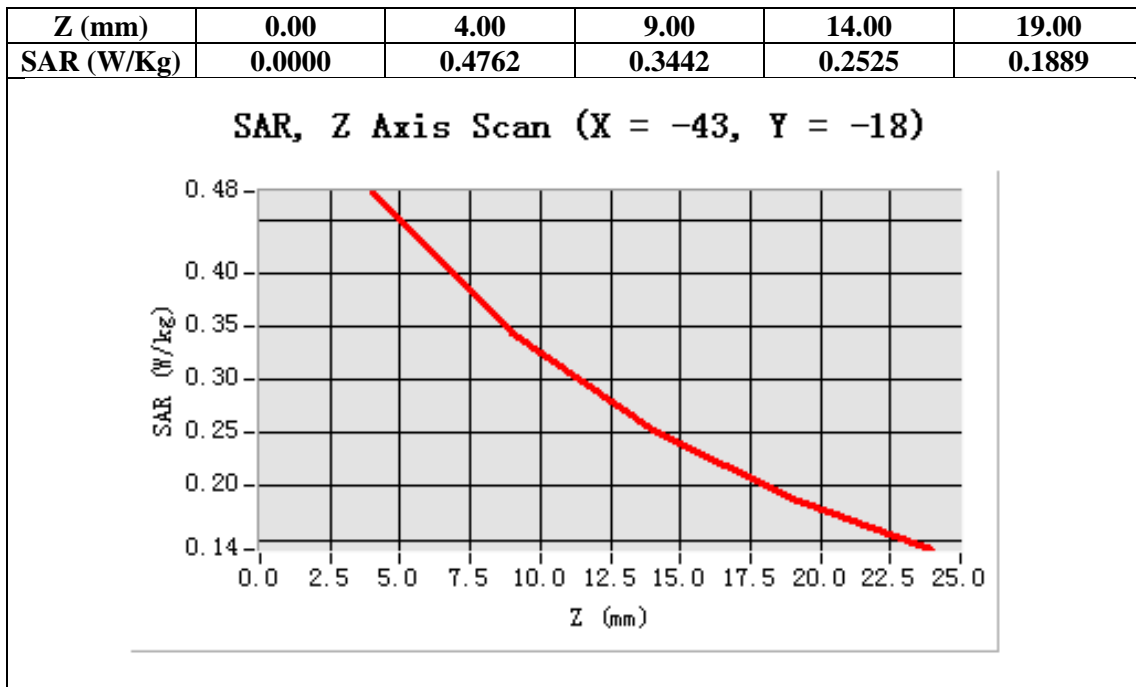

Test Laboratory: AGC Lab  
PCS 1900 Mid-Tilt-Right <SIM 1>  
DUT: Axe II 3G; Type: Z402

Date: Jan.25,2014

Communication System: Generic GSM; Communication System Band: PCS 1900; Duty Cycle: 1:8.3; Conv.F=4.72;  
Frequency: 1880 MHz; Medium parameters used:  $f = 1900$  MHz;  $\sigma = 1.4$  mho/m;  $\epsilon_r = 39.28$ ;  $\rho = 1000$  kg/m<sup>3</sup> ;  
Phantom section: Right Section  
Ambient temperature (°C): 21.0, Liquid temperature (°C): 21.0

SATIMO Configuration:

- Probe: EP165; Calibrated: 01/31/2013
- Sensor-Surface: 4mm (Mechanical Surface Detection)
- Phantom: Flat Phantom; Type: Elliptical Phantom
- Measurement SW: OpenSAR V4\_02\_01

Configuration/PCS1900 Mid-Tilt-Right/Area Scan: Measurement grid: dx=8mm, dy=8mm  
Configuration/PCS1900 Mid-Tilt-Right/Zoom Scan: Measurement grid: dx=8mm,  
dy=8mm, dz=5mm;

Area Scan	sam_direct_droit2_surf8mm.txt
ZoomScan	5x5x7,dx=8mm dy=8mm dz=5mm,Very fast
Phantom	Right head
Device Position	Tilt
Band	PCS 1900
Channels	Middle
Signal	TDMA (Crest factor: 8.0)

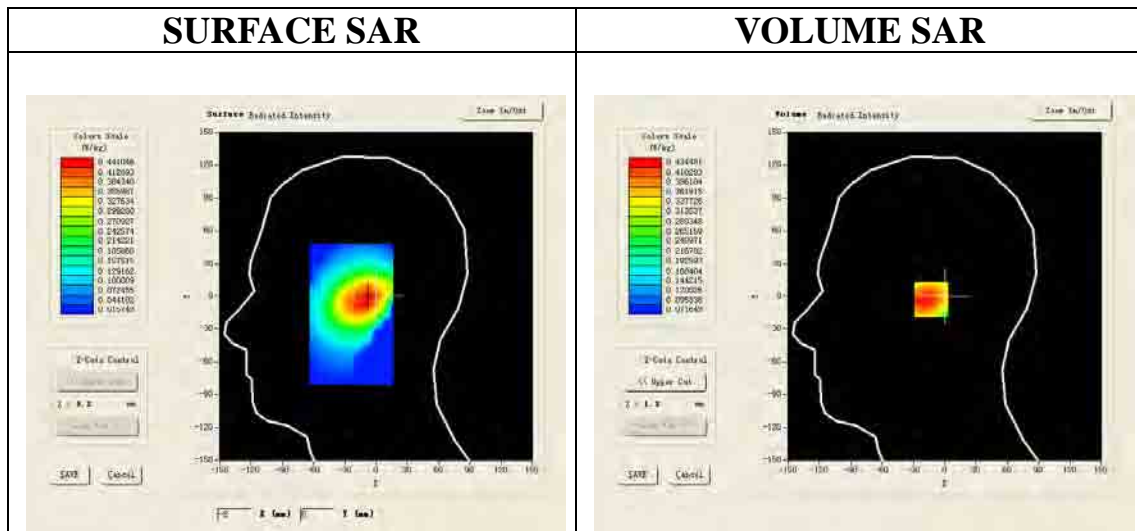

Maximum location: X=-9.00, Y=-3.00

SAR 10g (W/Kg)	0.300268
SAR 1g (W/Kg)	0.417847

Z (mm)	0.00	4.00	9.00	14.00	19.00
SAR (W/Kg)	0.0000	0.4279	0.3309	0.2520	0.1878

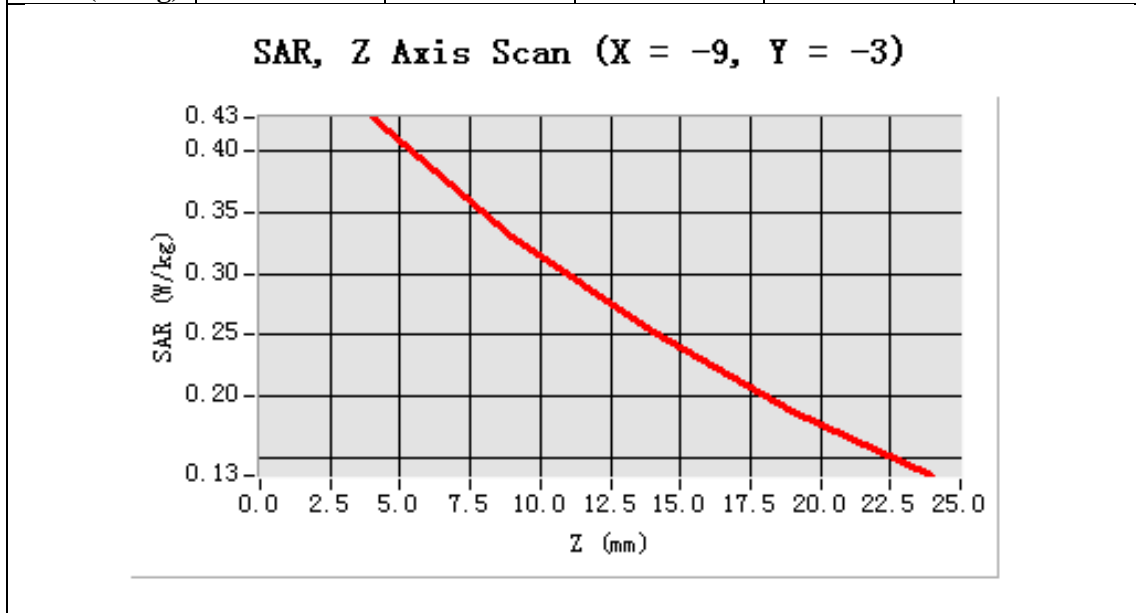

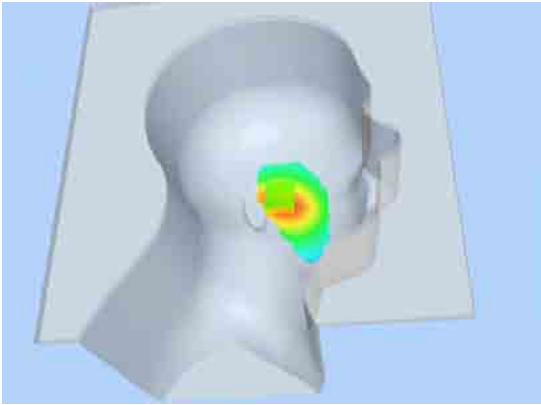
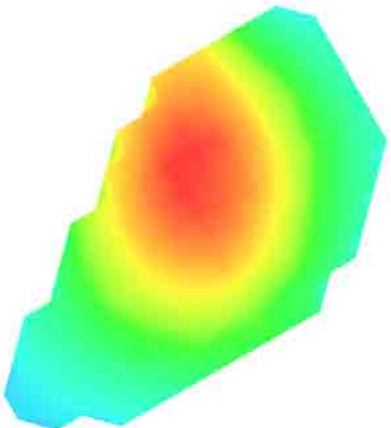
3D screen shot	Hot spot position
	

Test Laboratory: AGC Lab  
PCS 1900 Mid-Touch-Right<SIM 2>  
DUT: Axe II 3G; Type: Z402

Date: Jan.25,2014

Communication System: Generic GSM; Communication System Band: PCS 1900; Duty Cycle: 1:8.3; Conv.F=4.72;  
Frequency: 1880 MHz; Medium parameters used:  $f = 1900$  MHz;  $\sigma = 1.4$  mho/m;  $\epsilon_r = 39.28$ ;  $\rho = 1000$  kg/m<sup>3</sup> ;  
Phantom section: Right Section  
Ambient temperature (°C): 21.0, Liquid temperature (°C): 21.0

SATIMO Configuration:

- Probe: EP165; Calibrated: 01/31/2013
- Sensor-Surface: 4mm (Mechanical Surface Detection)
- Phantom: Flat Phantom; Type: Elliptical Phantom
- Measurement SW: OpenSAR V4\_02\_01

Configuration/PCS1900 Mid-Touch-Right/Area Scan: Measurement grid: dx=8mm, dy=8mm  
Configuration/PCS1900 Mid-Touch-Right/Zoom Scan: Measurement grid: dx=8mm, dy=8mm, dz=5mm;

Area Scan	sam_direct_droit2_surf8mm.txt
ZoomScan	5x5x7,dx=8mm dy=8mm dz=5mm,Very fast
Phantom	Right head
Device Position	Cheek
Band	PCS 1900
Channels	Middle
Signal	TDMA (Crest factor: 8.0)

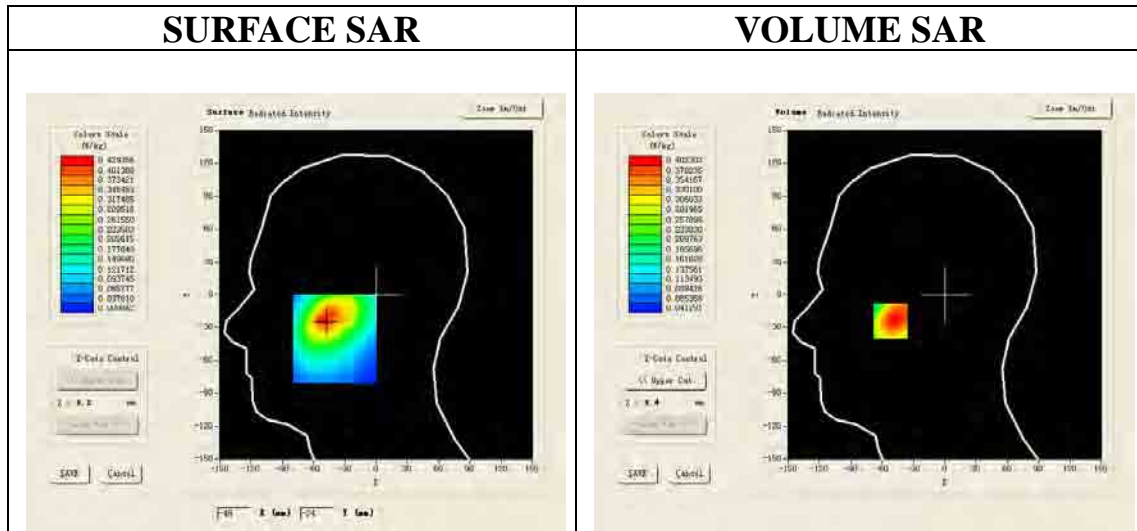

Maximum location: X=-52.00, Y=-24.00

SAR 10g (W/Kg)	0.264839
SAR 1g (W/Kg)	0.390473

Z (mm)	0.00	4.00	9.00	14.00	19.00
SAR (W/Kg)	0.0000	0.4023	0.2785	0.1995	0.1502

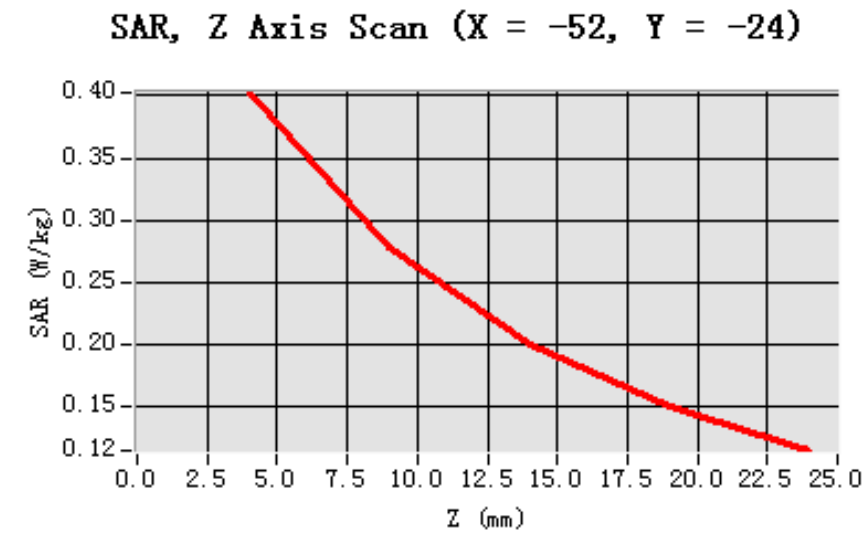

3D screen shot	Hot spot position
<p>A 3D rendering of a human head in profile, facing right. A small, localized area on the ear is highlighted with a color gradient from blue to red, indicating a hot spot of high SAR exposure.</p>	<p>A 2D heatmap visualization of the hot spot. It shows a central region of high intensity (red) that transitions through yellow and green to a lower intensity (blue) at the edges, representing the spatial distribution of the SAR exposure.</p>



Test Laboratory: AGC Lab  
PCS 1900 Mid-Body- Back <SIM 1>  
DUT: Axe II 3G; Type: Z402

Date: Jan.25,2014

Communication System: Generic GSM; Communication System Band: PCS 1900; Duty Cycle: 1:8.3; Conv.F=4.84;  
Frequency: 1880 MHz; Medium parameters used:  $f = 1900$  MHz;  $\sigma = 1.53$  mho/m;  $\epsilon_r = 53.76$ ;  $\rho = 1000$  kg/m<sup>3</sup> ;  
Phantom section: Flat Section  
Ambient temperature (°C): 21.0, Liquid temperature (°C): 21.0

SATIMO Configuration:

- Probe: EP165; Calibrated: 01/31/2013
- Sensor-Surface: 4mm (Mechanical Surface Detection)
- Phantom: Flat Phantom; Type: Elliptical Phantom
- Measurement SW: OpenSAR V4\_02\_01

Configuration/PCS1900 Mid-Body-Back/Area Scan: Measurement grid: dx=8mm, dy=8mm  
Configuration/PCS1900 Mid-Body-Back/Zoom Scan: Measurement grid: dx=8mm,  
dy=8mm, dz=5mm;

Area Scan	surf_sam_plan.txt
ZoomScan	5x5x7,dx=8mm dy=8mm dz=5mm,Very fast
Phantom	Validation plane
Device Position	Body Back
Band	PCS 1900
Channels	Middle
Signal	TDMA (Crest factor: 8.0)

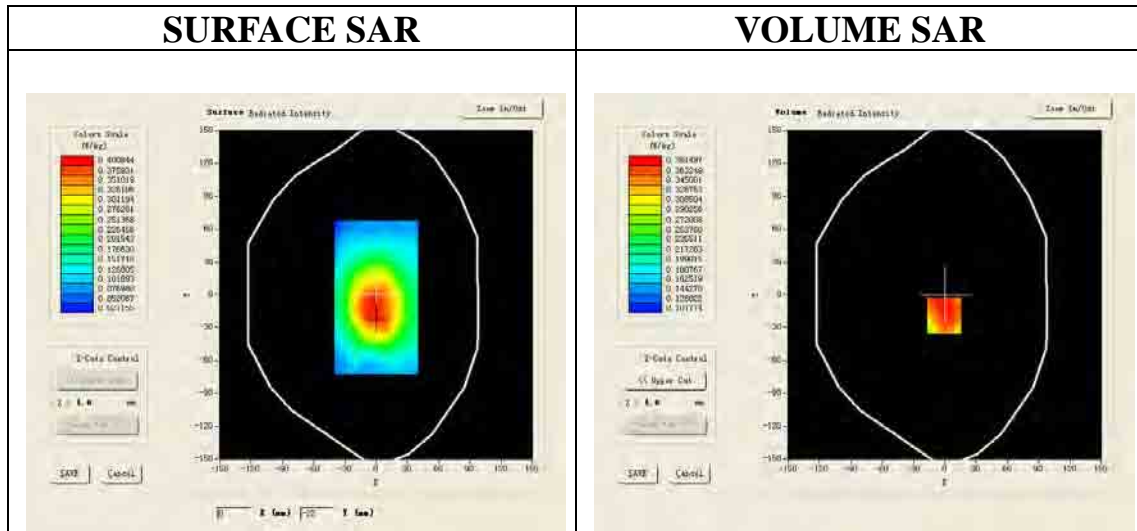

Maximum location: X=-1.00, Y=-19.00

SAR 10g (W/Kg)	0.307346
SAR 1g (W/Kg)	0.407217

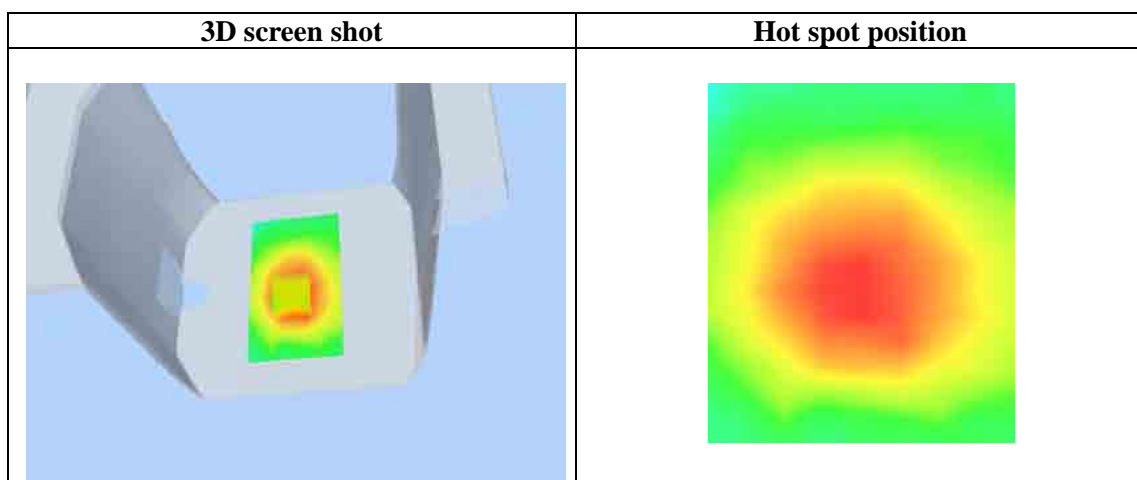
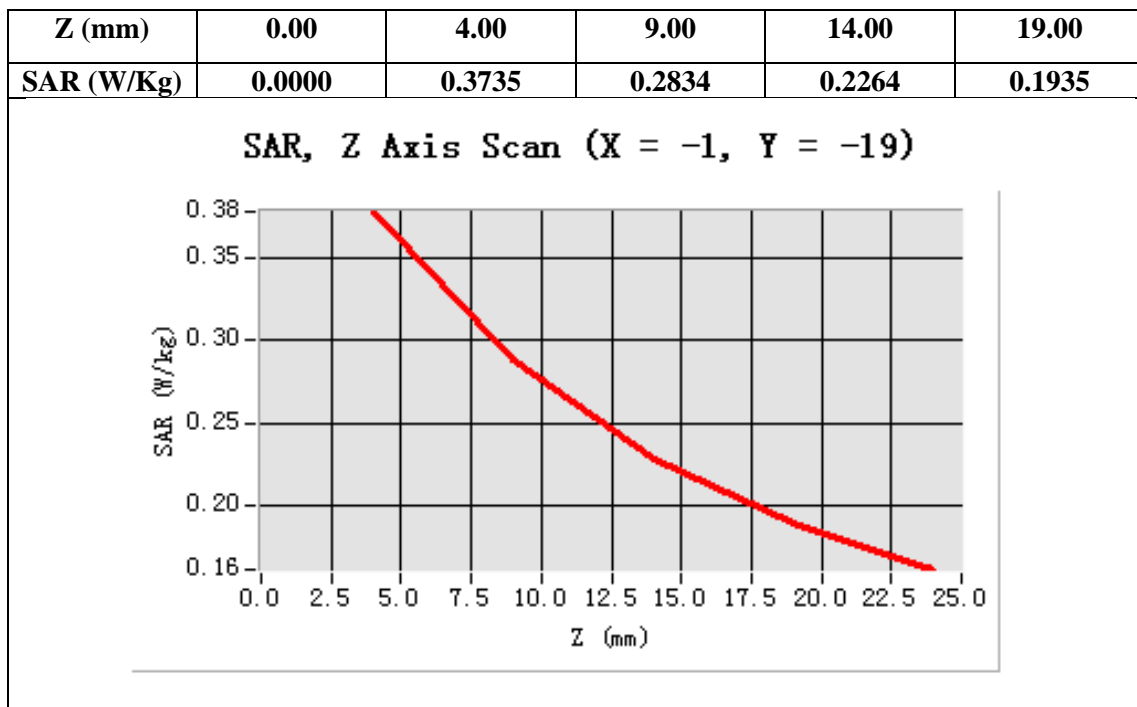

Test Laboratory: AGC Lab  
PCS 1900 Mid-Body -Front (MS) <SIM 1>  
DUT: Axe II 3G; Type: Z402

Date: Jan.25,2014

Communication System: Generic GSM; Communication System Band: PCS 1900; Duty Cycle: 1:8.3; Conv.F=4.84;  
Frequency: 1880 MHz; Medium parameters used:  $f = 1900$  MHz;  $\sigma = 1.53$  mho/m;  $\epsilon_r = 53.76$ ;  $\rho = 1000$  kg/m<sup>3</sup> ;  
Phantom section: Flat Section  
Ambient temperature (°C): 21.0, Liquid temperature (°C): 21.0

SATIMO Configuration:

- Probe: EP165; Calibrated: 01/31/2013
- Sensor-Surface: 4mm (Mechanical Surface Detection)
- Phantom: Flat Phantom; Type: Elliptical Phantom
- Measurement SW: OpenSAR V4\_02\_01

Configuration/PCS1900 Mid-Body- Front /Area Scan: Measurement grid: dx=8mm, dy=8mm  
Configuration/PCS1900 Mid-Body- Front /Zoom Scan: Measurement grid: dx=8mm, dy=8mm, dz=5mm;

Area Scan	surf_sam_plan.txt
ZoomScan	5x5x7,dx=8mm dy=8mm dz=5mm,Very fast
Phantom	Validation plane
Device Position	Body Front
Band	PCS 1900
Channels	Middle
Signal	TDMA (Crest factor: 8.0)

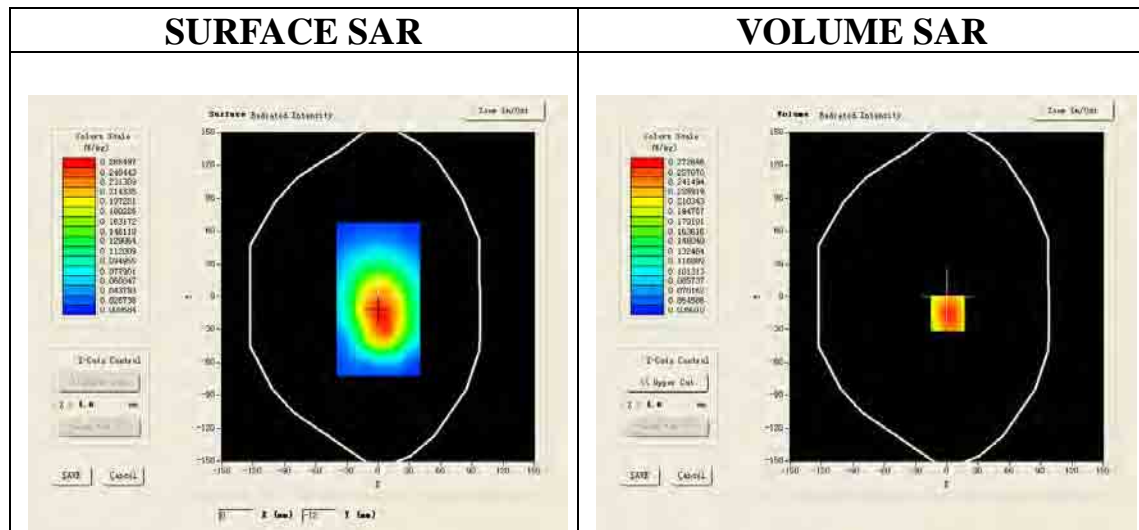

Maximum location: X=1.00, Y=-15.00

SAR 10g (W/Kg)	0.188154
SAR 1g (W/Kg)	0.289425

Z (mm)	0.00	4.00	9.00	14.00	19.00
SAR (W/Kg)	0.0000	0.2762	0.1897	0.1245	0.0805

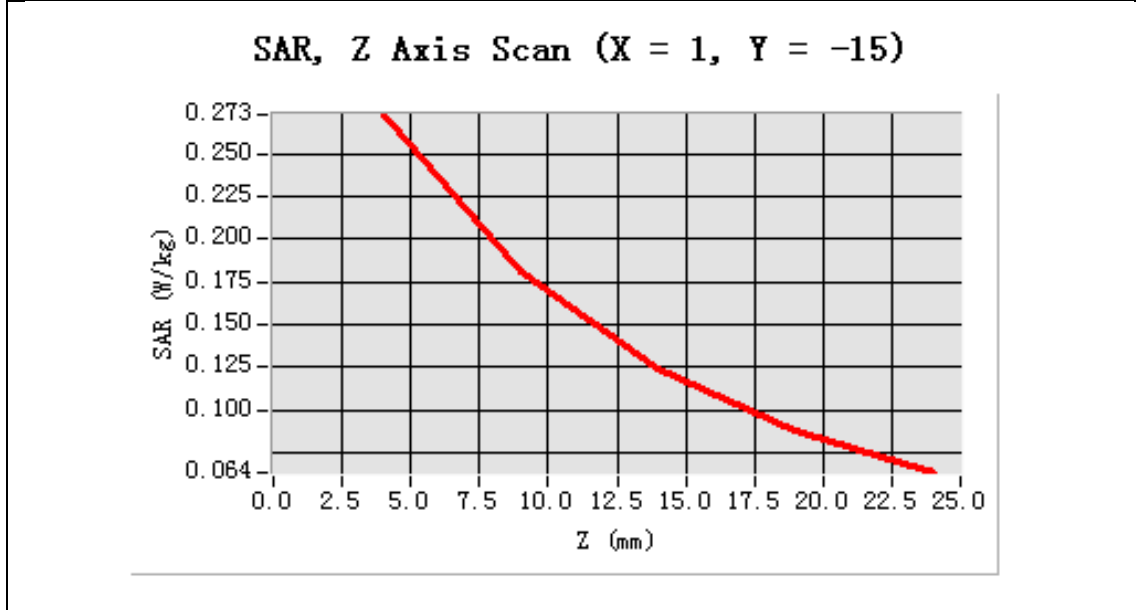

3D screen shot	Hot spot position

Test Laboratory: AGC Lab  
WCDMA Band II Mid-Touch-Left (RMC)  
DUT: Axe II 3G; Type: Z402

Date: Jan.25,2014

Communication System: UMTS; Communication System Band: Band II UTRA/FDD ;Duty Cycle:1:1;Conv.F=4.72  
Frequency: 1880 MHz; Medium parameters used:  $f = 1900$  MHz;  $\sigma = 1.4$  mho/m;  $\epsilon_r = 39.28$ ;  $\rho = 1000$  kg/m<sup>3</sup> ;  
Phantom section: Left Section  
Ambient temperature (°C):21, Liquid temperature (°C):21

SATIMO Configuration:

- Probe: EP165; Calibrated: 01/31/2013
- Sensor-Surface: 4mm (Mechanical Surface Detection)
- Phantom: Flat Phantom; Type: Elliptical Phantom
- Measurement SW: OpenSAR V4\_02\_01

Configuration/ WCDMA Band II Mid-Touch-Left/Area Scan: Measurement grid: dx=8mm, dy=8mm  
Configuration/ WCDMA Band II Mid-Touch-Left/Zoom Scan: Measurement grid:  
dx=8mm,dy=8mm,dz=5mm;

Area Scan	sam_direct_droit2_surf8mm.txt
ZoomScan	5x5x7,dx=8mm dy=8mm dz=5mm,Very fast
Phantom	Left head
Device Position	Cheek
Band	WCDMA Band II
Channels	Middle
Signal	TDMA (Crest factor: 1.0)

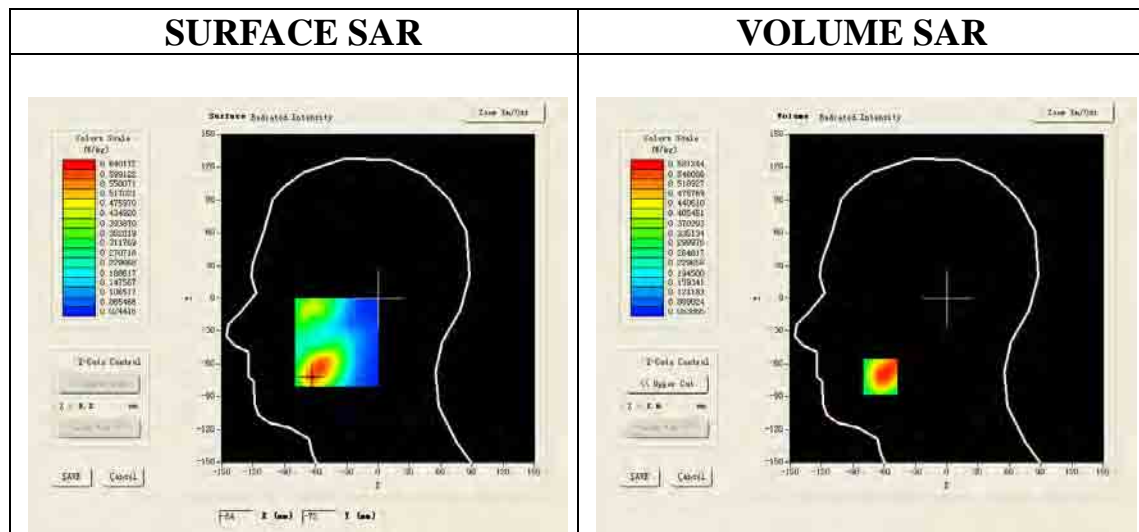

Maximum location: X=-64.00, Y=-72.00

SAR 10g (W/Kg)	0.357636
SAR 1g (W/Kg)	0.560925

Z (mm)	0.00	4.00	9.00	14.00	19.00
SAR (W/Kg)	0.0000	0.5812	0.3744	0.2532	0.1853

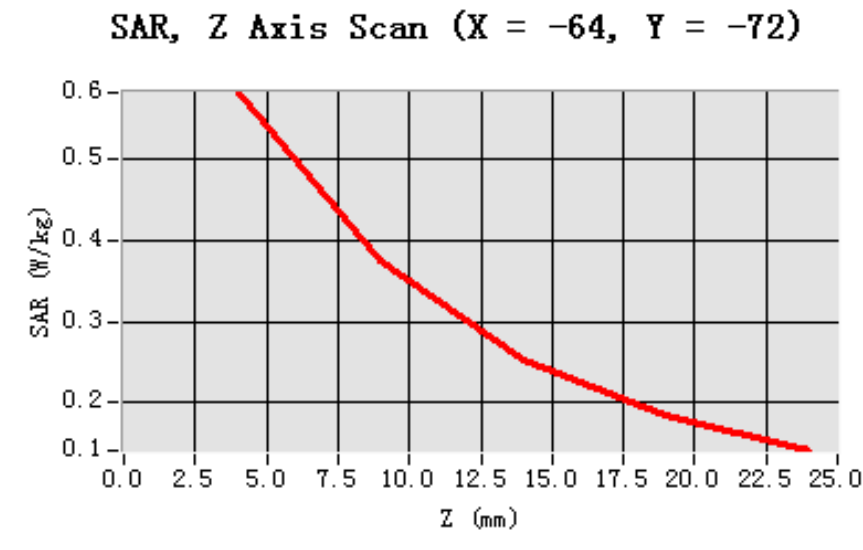

3D screen shot	Hot spot position

Test Laboratory: AGC Lab  
WCDMA Band II Mid-Tilt-Left (RMC)  
DUT: Axe II 3G; Type: Z402

Date: Jan.25,2014

Communication System: UMTS; Communication System Band: Band II UTRA/FDD ;Duty Cycle:1:1; Conv.F=4.72  
Frequency: 1880 MHz; Medium parameters used:  $f = 1900$  MHz;  $\sigma = 1.4$  mho/m; $\epsilon_r = 39.28$ ;  $\rho = 1000$  kg/m<sup>3</sup> ;  
Phantom section: Left Section  
Ambient temperature (°C):21, Liquid temperature (°C):21

SATIMO Configuration:

- Probe: EP165; Calibrated: 01/31/2013
- Sensor-Surface: 4mm (Mechanical Surface Detection)
- Phantom: Flat Phantom; Type: Elliptical Phantom
- Measurement SW: OpenSAR V4\_02\_01

Configuration/ WCDMA Band II Mid-Tilt-Left/Area Scan: Measurement grid: dx=8mm, dy=8mm  
Configuration/ WCDMA Band II Mid-Tilt-Left/Zoom Scan: Measurement grid: dx=8mm, dy=8mm, dz=5mm;

Area Scan	sam_direct_droit2_surf8mm.txt
ZoomScan	5x5x7,dx=8mm dy=8mm dz=5mm,Very fast
Phantom	Left head
Device Position	Tilt
Band	WCDMA Band II
Channels	Middle
Signal	TDMA (Crest factor: 1.0)

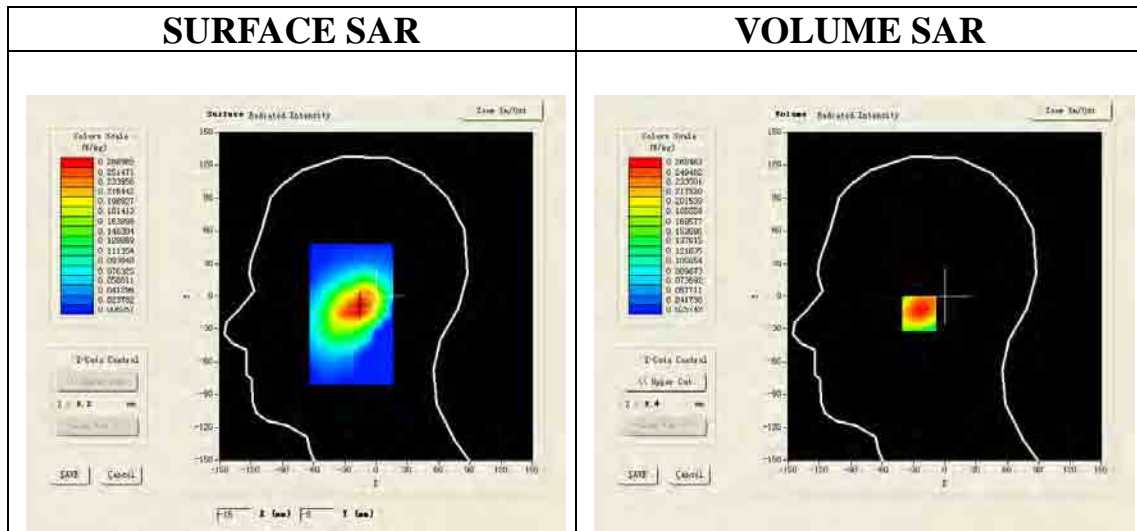

Maximum location: X=-20.00, Y=-16.00

SAR 10g (W/Kg)	0.161537
SAR 1g (W/Kg)	0.250714

Z (mm)	0.00	4.00	9.00	14.00	19.00
SAR (W/Kg)	0.0000	0.2639	0.1787	0.1233	0.0886

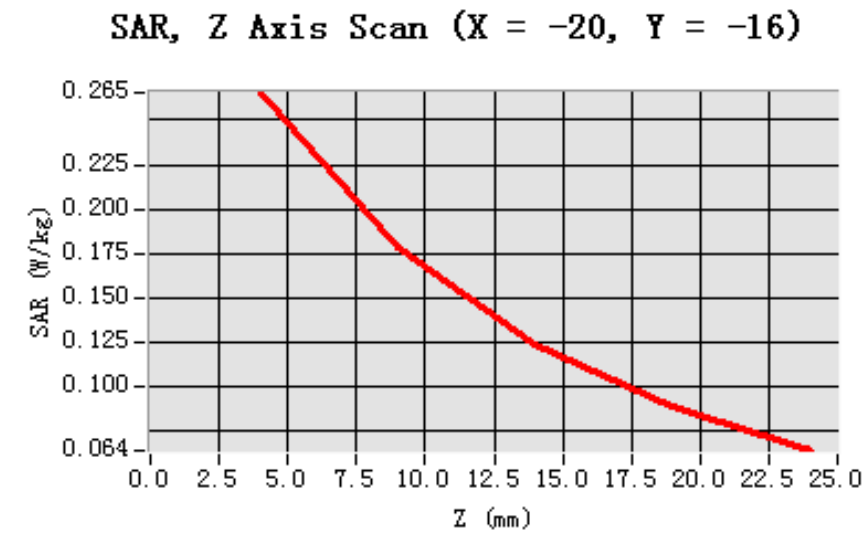

**3D screen shot**

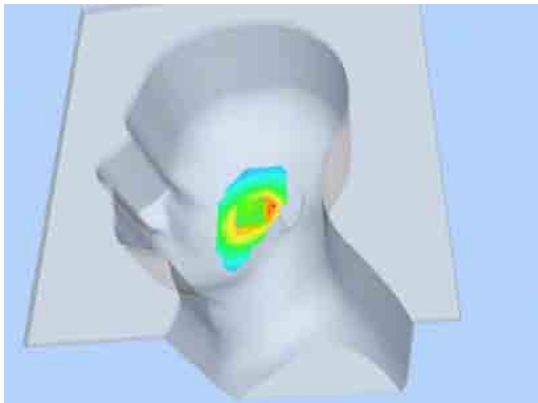

**Hot spot position**

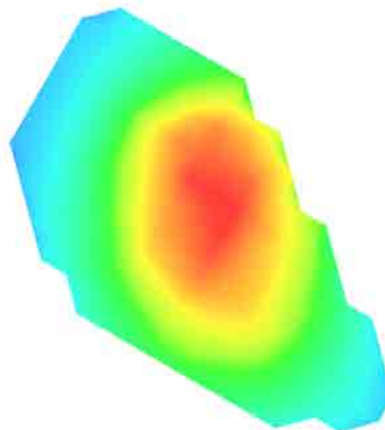



Test Laboratory: AGC Lab  
WCDMA Band II Low-Touch-Right (RMC)  
DUT: Axe II 3G; Type: Z402

Date: Jan.25,2014

Communication System: UMTS; Communication System Band: Band II UTRA/FDD ;Duty Cycle:1:1; Conv.F=4.72  
Frequency: 1852.4 MHz; Medium parameters used:  $f = 1900$  MHz;  $\sigma = 1.39$  mho/m;  $\epsilon_r = 40.15$ ;  $\rho = 1000$  kg/m<sup>3</sup> ;  
Phantom section: Right Section  
Ambient temperature (°C):21, Liquid temperature (°C):21

SATIMO Configuration:

- Probe: EP165; Calibrated: 01/31/2013
- Sensor-Surface: 4mm (Mechanical Surface Detection)
- Phantom: Flat Phantom; Type: Elliptical Phantom
- Measurement SW: OpenSAR V4\_02\_01

Configuration/ WCDMA band II Low-Touch-Right/Area Scan: Measurement grid: dx=8mm, dy=8mm  
Configuration/ WCDMA band II Low-Touch-Right/Zoom Scan: Measurement grid: dx=8mm, dy=8mm, dz=5mm;

Area Scan	sam_direct_droit2_surf8mm.txt
ZoomScan	5x5x7,dx=8mm dy=8mm dz=5mm,Very fast
Phantom	Right head
Device Position	Cheek
Band	WCDMA band II
Channels	Low
Signal	TDMA (Crest factor: 1.0)

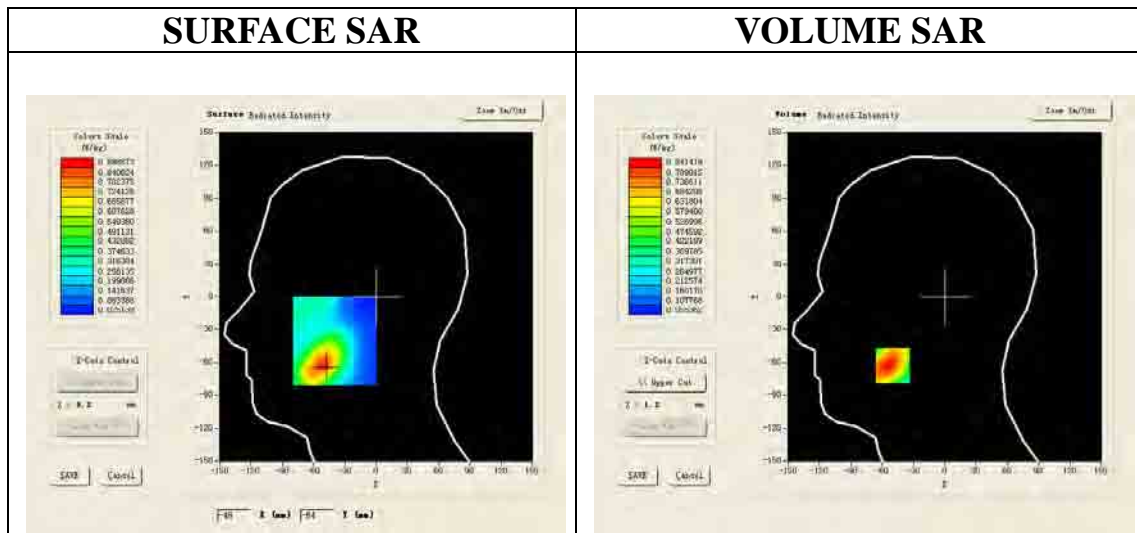

Maximum location: X=-50.00, Y=-63.00

SAR 10g (W/Kg)	0.522641
SAR 1g (W/Kg)	0.815238

Z (mm)	0.00	4.00	9.00	14.00	19.00
SAR (W/Kg)	0.0000	0.8327	0.5763	0.3983	0.2772

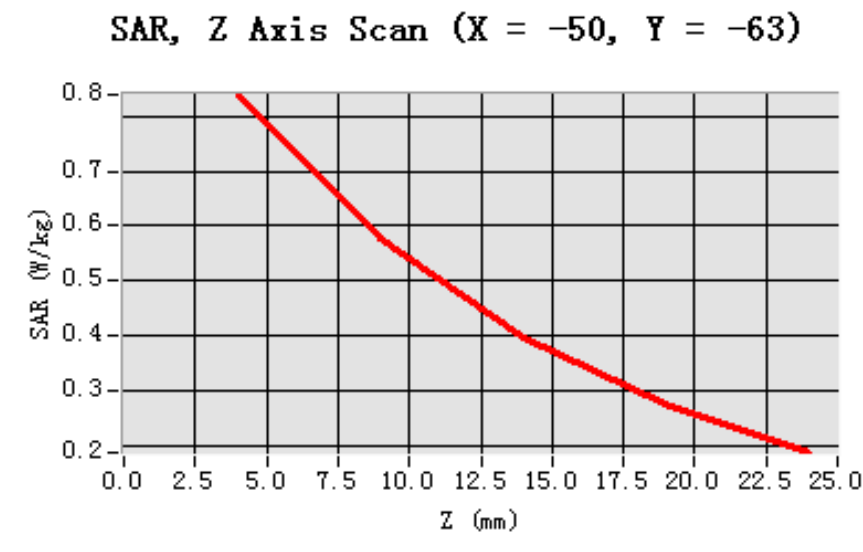

3D screen shot	Hot spot position
<p>A 3D rendering of a human head model. A small, rectangular area on the side of the head, near the ear, is highlighted with a color gradient from blue to red, indicating a localized high SAR region (hot spot).</p>	<p>A 2D heatmap showing the spatial distribution of the SAR hot spot. The color scale ranges from blue (low SAR) to red (high SAR), with the highest intensity concentrated in a central, roughly circular area.</p>

Test Laboratory: AGC Lab  
WCDMA Band II Mid-Touch-Right (RMC)  
DUT: Axe II 3G; Type: Z402

Date: Jan.25,2014

Communication System: UMTS; Communication System Band: Band II UTRA/FDD ;Duty Cycle:1:1; Conv.F=4.72  
Frequency: 1880 MHz; Medium parameters used:  $f = 1900$  MHz;  $\sigma = 1.4$  mho/m;  $\epsilon_r = 39.28$ ;  $\rho = 1000$  kg/m<sup>3</sup> ;  
Phantom section: Right Section  
Ambient temperature (°C):21, Liquid temperature (°C):21

SATIMO Configuration:

- Probe: EP165; Calibrated: 01/31/2013
- Sensor-Surface: 4mm (Mechanical Surface Detection)
- Phantom: Flat Phantom; Type: Elliptical Phantom
- Measurement SW: OpenSAR V4\_02\_01

Configuration/ WCDMA band II Mid-Touch-Right/Area Scan: Measurement grid: dx=8mm, dy=8mm  
Configuration/ WCDMA band II Mid-Touch-Right/Zoom Scan: Measurement grid: dx=8mm, dy=8mm, dz=5mm;

Area Scan	sam_direct_droit2_surf8mm.txt
ZoomScan	5x5x7,dx=8mm dy=8mm dz=5mm,Very fast
Phantom	Right head
Device Position	Cheek
Band	WCDMA band II
Channels	Middle
Signal	TDMA (Crest factor: 1.0)

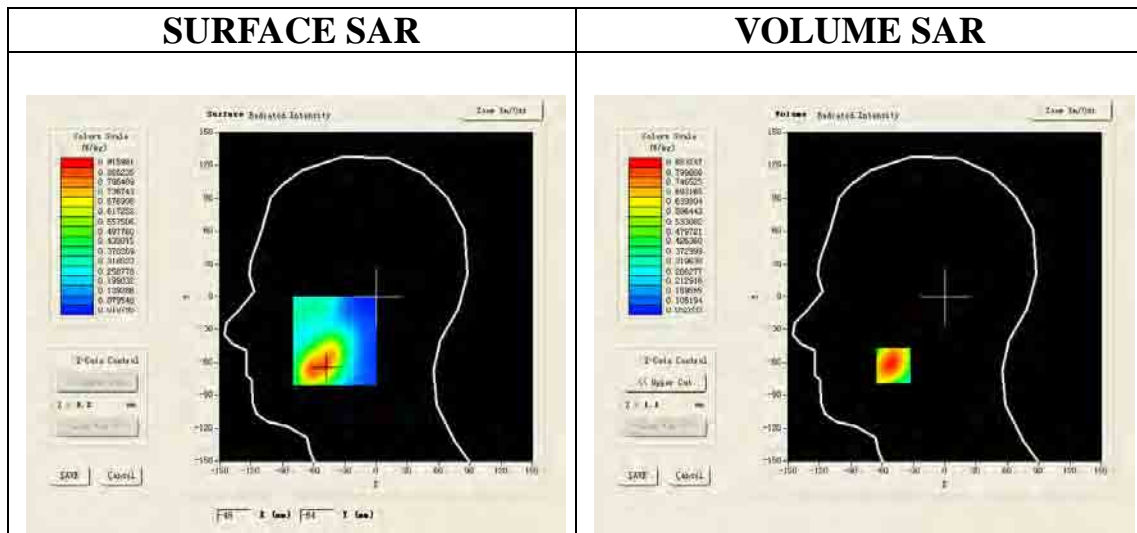

Maximum location: X=-49.00, Y=-63.00

SAR 10g (W/Kg)	0.521527
SAR 1g (W/Kg)	0.826351

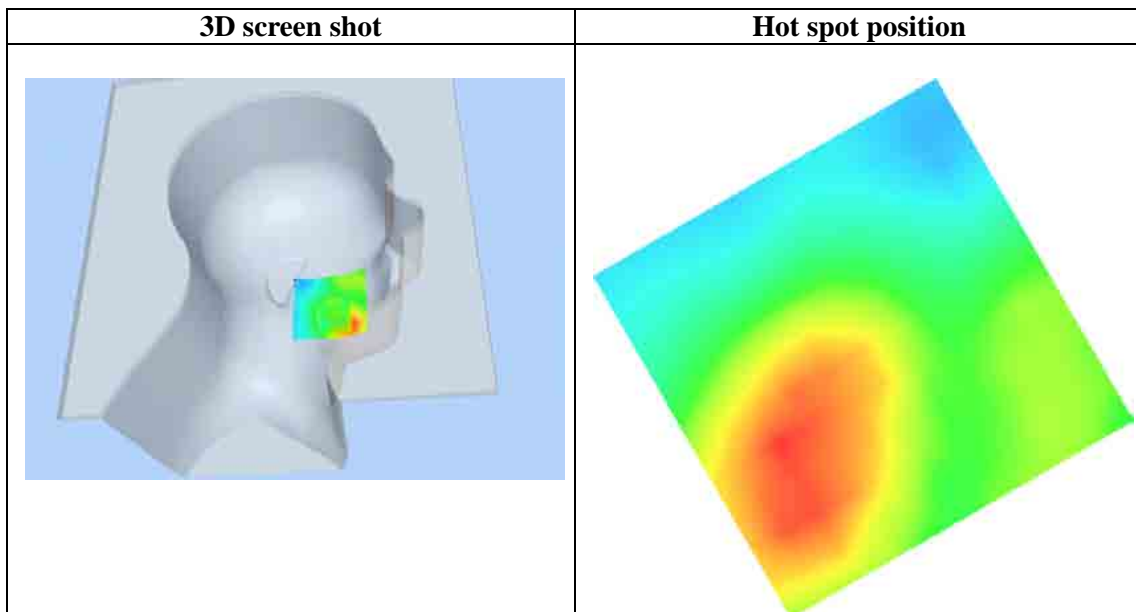
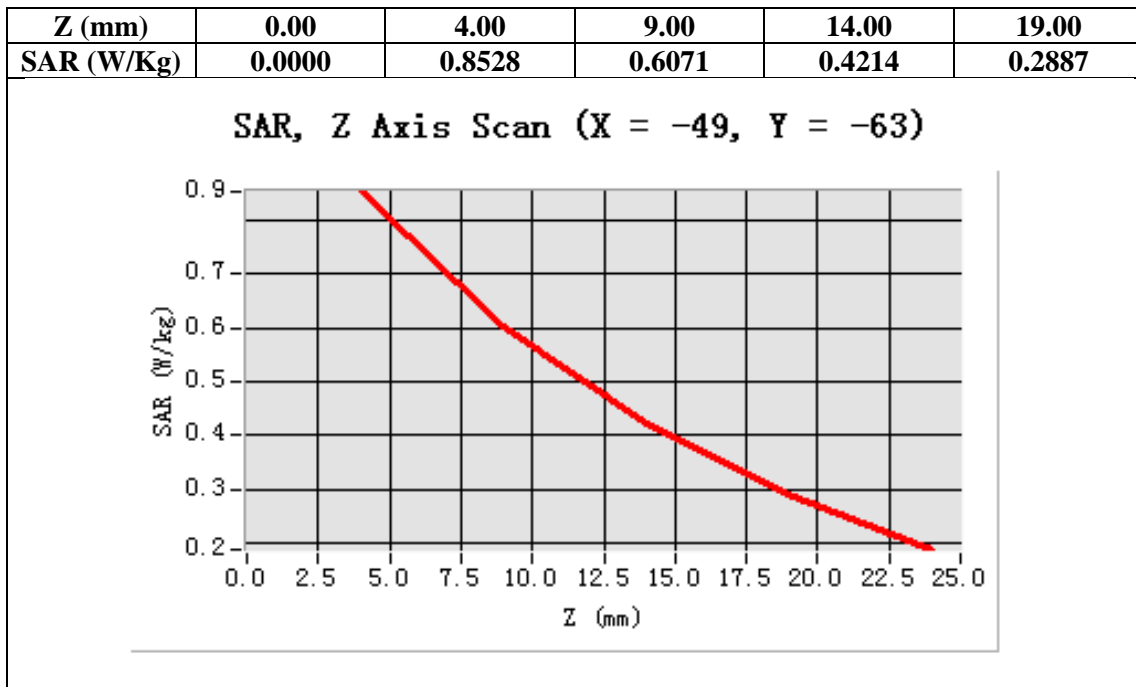

Test Laboratory: AGC Lab  
WCDMA Band II High-Touch-Right (RMC)  
DUT: Axe II 3G; Type: Z402

Date: Jan.25,2014

Communication System: UMTS; Communication System Band: Band II UTRA/FDD ;Duty Cycle:1:1; Conv.F=4.72  
Frequency: 1907.6 MHz; Medium parameters used:  $f = 1900$  MHz;  $\sigma = 1.42$  mho/m;  $\epsilon_r = 40.35$ ;  $\rho = 1000$  kg/m<sup>3</sup> ;  
Phantom section: Right Section  
Ambient temperature (°C):21, Liquid temperature (°C):21

SATIMO Configuration:

- Probe: EP165; Calibrated: 01/31/2013
- Sensor-Surface: 4mm (Mechanical Surface Detection)
- Phantom: Flat Phantom; Type: Elliptical Phantom
- Measurement SW: OpenSAR V4\_02\_01

Configuration/ WCDMA band II High-Touch-Right/Area Scan: Measurement grid: dx=8mm, dy=8mm  
Configuration/ WCDMA band II High-Touch-Right/Zoom Scan: Measurement grid: dx=8mm, dy=8mm, dz=5mm;

<b>Area Scan</b>	sam_direct_droit2_surf8mm.txt
<b>ZoomScan</b>	5x5x7,dx=8mm dy=8mm dz=5mm,Very fast
<b>Phantom</b>	Right head
<b>Device Position</b>	Cheek
<b>Band</b>	WCDMA band II
<b>Channels</b>	High
<b>Signal</b>	TDMA (Crest factor: 1.0)

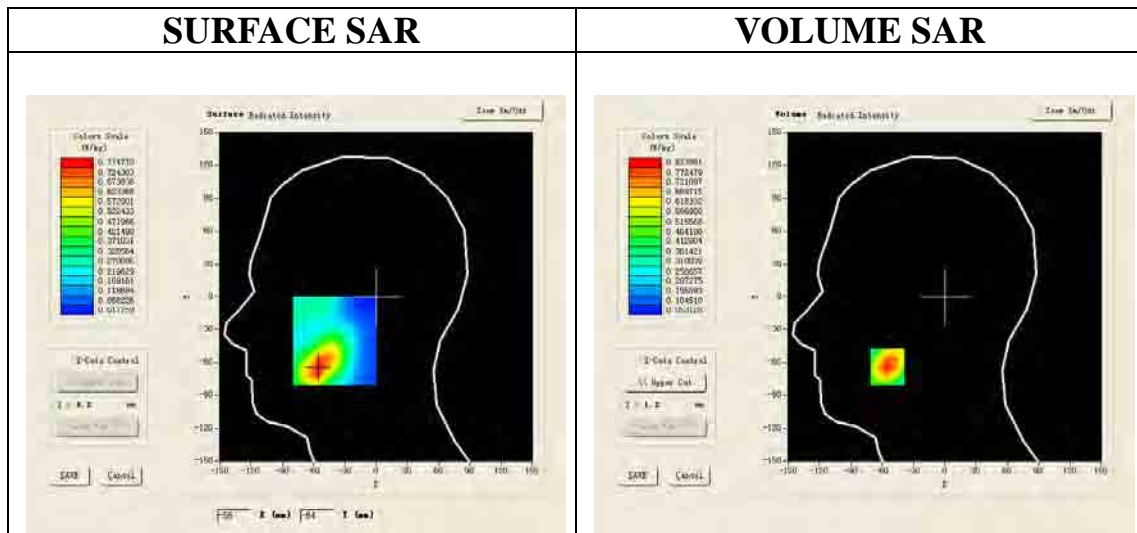

**Maximum location: X=-55.00, Y=-64.00**

<b>SAR 10g (W/Kg)</b>	0.454137
<b>SAR 1g (W/Kg)</b>	0.772318

Z (mm)	0.00	4.00	9.00	14.00	19.00
SAR (W/Kg)	0.0000	0.8239	0.4609	0.2835	0.2086

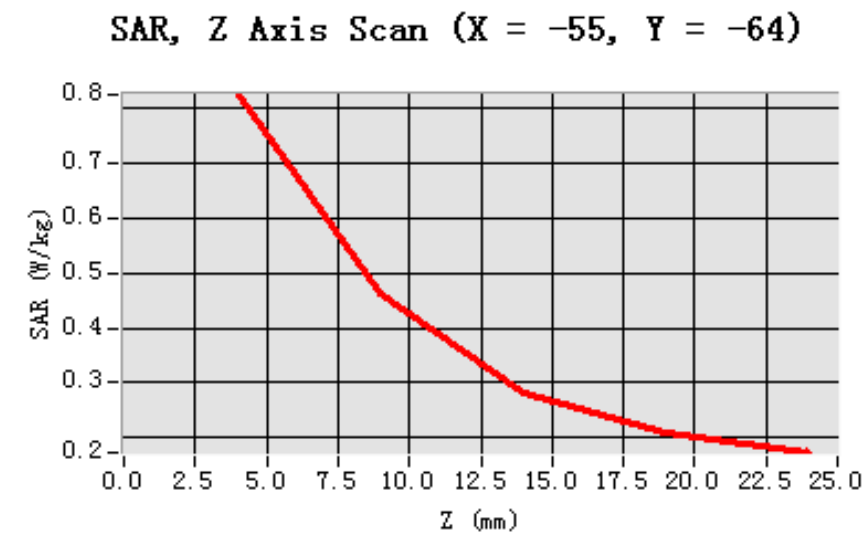

3D screen shot	Hot spot position
<p>A 3D rendering of a human head model in profile, facing right. A small, rectangular area on the ear is highlighted with a color gradient from blue to red, indicating a hot spot of high SAR exposure.</p>	<p>A 2D heatmap representing the hot spot position. The color scale ranges from blue (low SAR) to red (high SAR). The highest SAR values are concentrated in a localized area, shown in red and yellow, surrounded by green and blue regions.</p>

Test Laboratory: AGC Lab  
WCDMA Band II Mid-Tilt-Right <RMC>  
DUT: Axe II 3G; Type: Z402

Date: Jan.25,2014

Communication System: UMTS; Communication System Band: Band II UTRA/FDD ;Duty Cycle:1:1; Conv.F=4.72  
Frequency: 1880 MHz; Medium parameters used:  $f = 1900$  MHz;  $\sigma = 1.4$  mho/m; $\epsilon_r = 39.28$ ;  $\rho = 1000$  kg/m<sup>3</sup> ;  
Phantom section: Right Section  
Ambient temperature (°C):21, Liquid temperature (°C):21

SATIMO Configuration:

- Probe: EP165; Calibrated: 01/31/2013
- Sensor-Surface: 4mm (Mechanical Surface Detection)
- Phantom: Flat Phantom; Type: Elliptical Phantom
- Measurement SW: OpenSAR V4\_02\_01

Configuration/PCS1900 Mid-Tilt-Right/Area Scan: Measurement grid: dx=8mm, dy=8mm  
Configuration/PCS1900 Mid-Tilt-Right/Zoom Scan: Measurement grid: dx=8mm, dy=8mm, dz=5mm;

Area Scan	sam_direct_droit2_surf8mm.txt
ZoomScan	5x5x7,dx=8mm dy=8mm dz=5mm,Very fast
Phantom	Right head
Device Position	Tilt
Band	WCDMA band II
Channels	Middle
Signal	TDMA (Crest factor: 1.0)

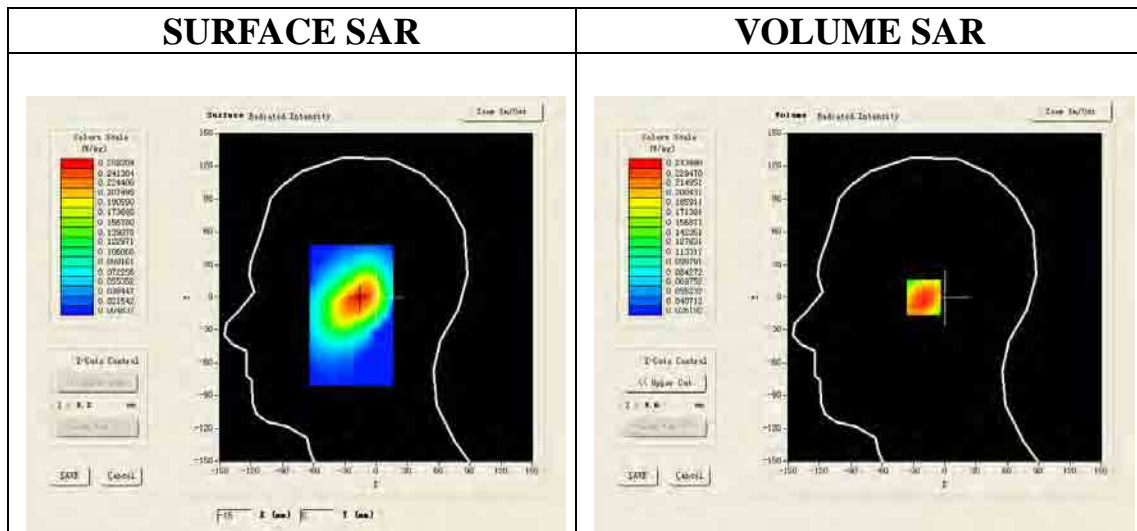

Maximum location: X=-17.00, Y=0.00

SAR 10g (W/Kg)	0.155249
SAR 1g (W/Kg)	0.236173

Z (mm)	0.00	4.00	9.00	14.00	19.00
SAR (W/Kg)	0.0000	0.2440	0.1818	0.1304	0.0886

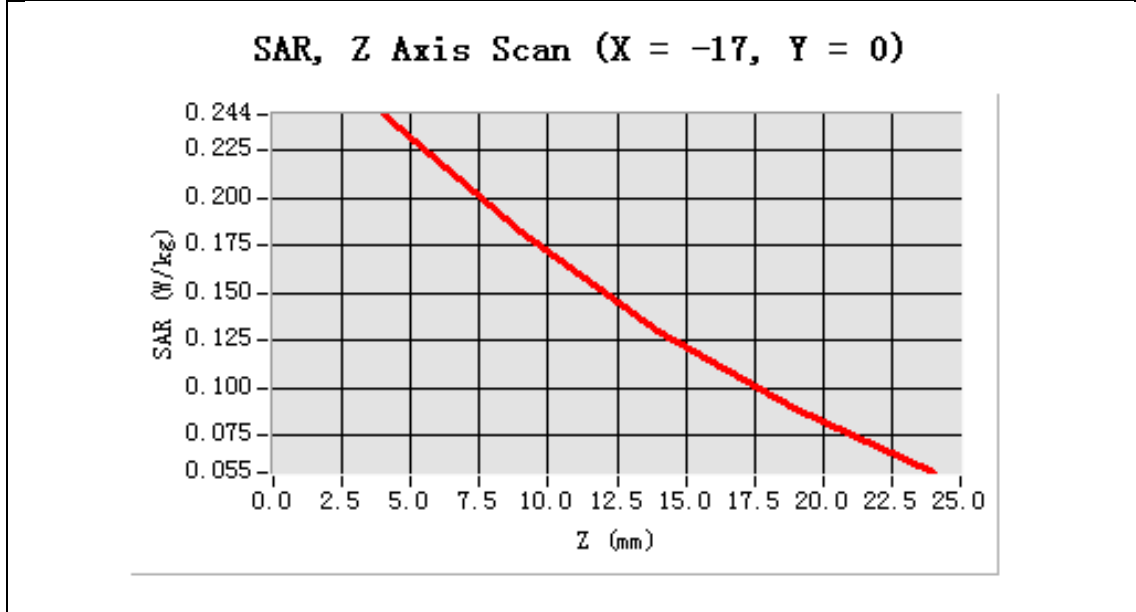

3D screen shot	Hot spot position
<p>A 3D rendering of a human head in profile, facing right. A localized area of high SAR is highlighted on the ear, shown in a color gradient from blue (low) to red (high).</p>	<p>A 2D heatmap representing the hot spot position. The central area is red, indicating the highest SAR, surrounded by yellow and green, indicating decreasing SAR levels.</p>



Test Laboratory: AGC Lab  
WCDMA Band II Low-Body-Towards Grounds (RMC)  
DUT: Axe II 3G; Type: Z402

Date: Jan.25,2014

Communication System: UMTS; Communication System Band: Band II UTRA/FDD ;Duty Cycle:1:1; ConvF=4.84  
Frequency: 1852.4 MHz; Medium parameters used:  $f = 1900$  MHz;  $\sigma=1.50$  mho/m;  $\epsilon_r=54.01$ ;  $\rho= 1000$  kg/m<sup>3</sup> ;  
Phantom section: Flat Section  
Ambient temperature (°C):21, Liquid temperature (°C):21

SATIMO Configuration:

- Probe: EP165; Calibrated: 01/31/2013
- Sensor-Surface: 4mm (Mechanical Surface Detection)
- Phantom: Flat Phantom; Type: Elliptical Phantom
- Measurement SW: OpenSAR V4\_02\_01

Configuration/ WCDMA band II Low-Body-back/Area Scan: Measurement grid: dx=8mm, dy=8mm  
Configuration/ WCDMA band II Low-Body-back/Zoom Scan: Measurement grid: dx=8mm, dy=8mm, dz=5mm;

Area Scan	surf_sam_plan.txt
ZoomScan	5x5x7,dx=8mm dy=8mm dz=5mm,Very fast
Phantom	Validation plane
Device Position	Body Back
Band	WCDMA band II
Channels	Low
Signal	TDMA (Crest factor: 1.0)

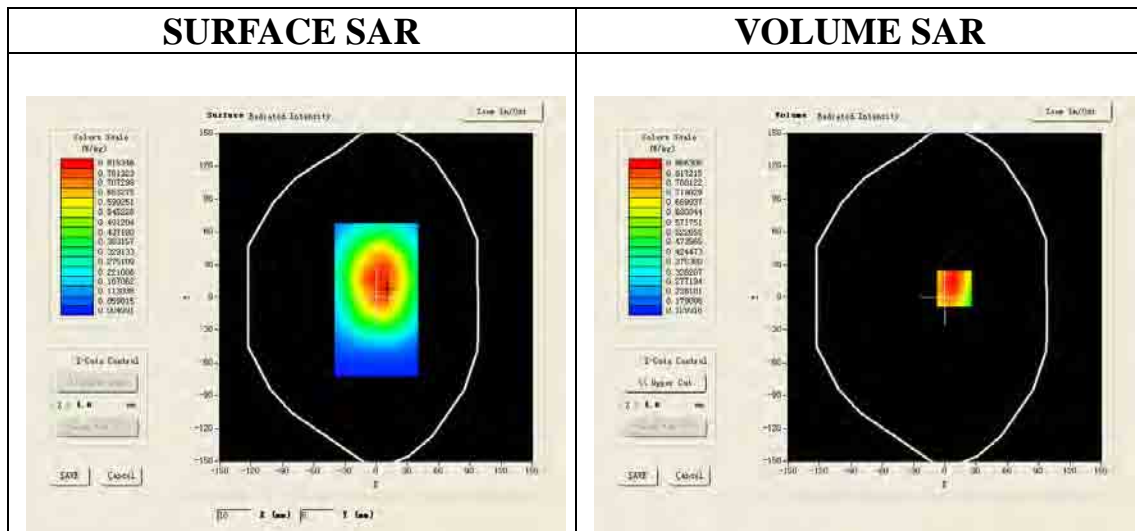

Maximum location: X=9.00, Y=8.00

SAR 10g (W/Kg)	0.615129
SAR 1g (W/Kg)	0.906316

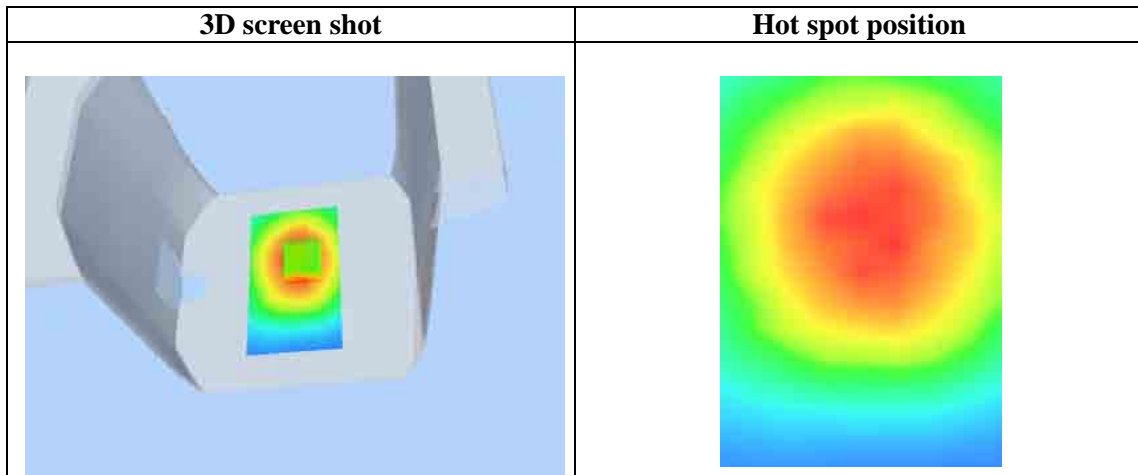
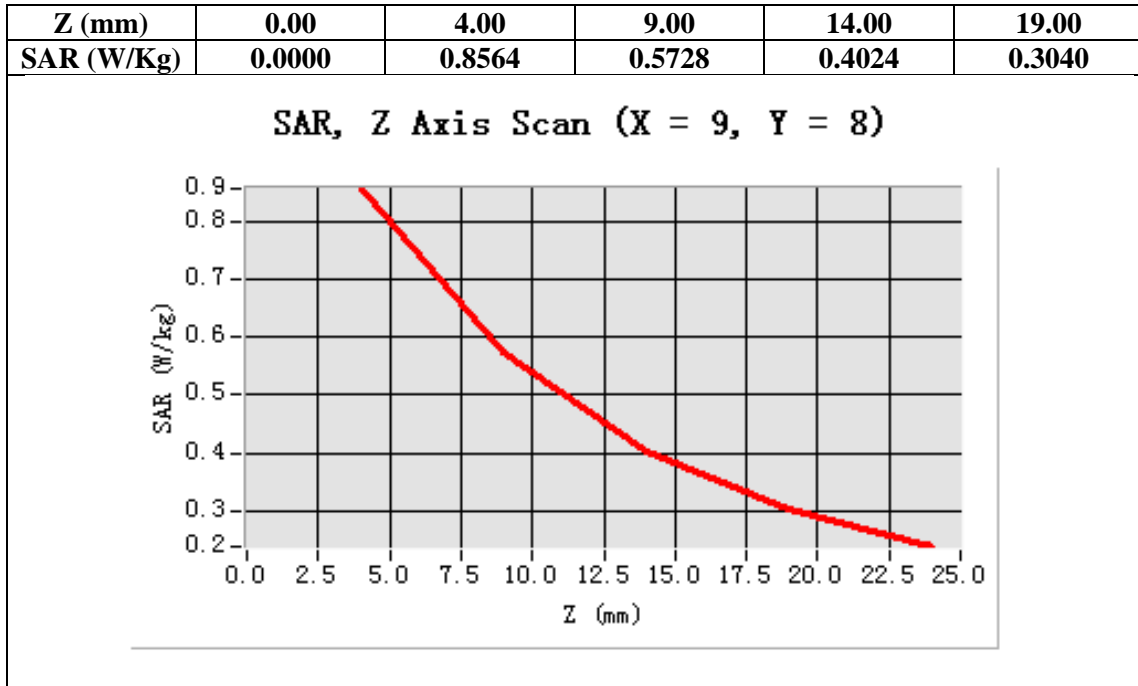

Test Laboratory: AGC Lab  
WCDMA Band II Mid-Body-Towards Grounds (RMC)  
DUT: Axe II 3G; Type: Z402

Date: Jan.25,2014

Communication System: UMTS; Communication System Band: Band II UTRA/FDD ;Duty Cycle:1:1; ConvF=4.84  
Frequency: 1880 MHz; Medium parameters used:  $f = 1900$  MHz;  $\sigma=1.53$  mho/m;  $\epsilon_r=53.76$ ;  $\rho= 1000$  kg/m<sup>3</sup> ;  
Phantom section: Flat Section  
Ambient temperature (°C):21, Liquid temperature (°C):21

SATIMO Configuration:

- Probe: EP165; Calibrated: 01/31/2013
- Sensor-Surface: 4mm (Mechanical Surface Detection)
- Phantom: Flat Phantom; Type: Elliptical Phantom
- Measurement SW: OpenSAR V4\_02\_01

Configuration/ WCDMA band II Mid-Body-back/Area Scan: Measurement grid: dx=8mm, dy=8mm  
Configuration/ WCDMA band II Mid-Body-back/Zoom Scan: Measurement grid: dx=8mm, dy=8mm, dz=5mm;

Area Scan	surf_sam_plan.txt
ZoomScan	5x5x7,dx=8mm dy=8mm dz=5mm,Very fast
Phantom	Validation plane
Device Position	Body Back
Band	WCDMA band II
Channels	Middle
Signal	TDMA (Crest factor: 1.0)

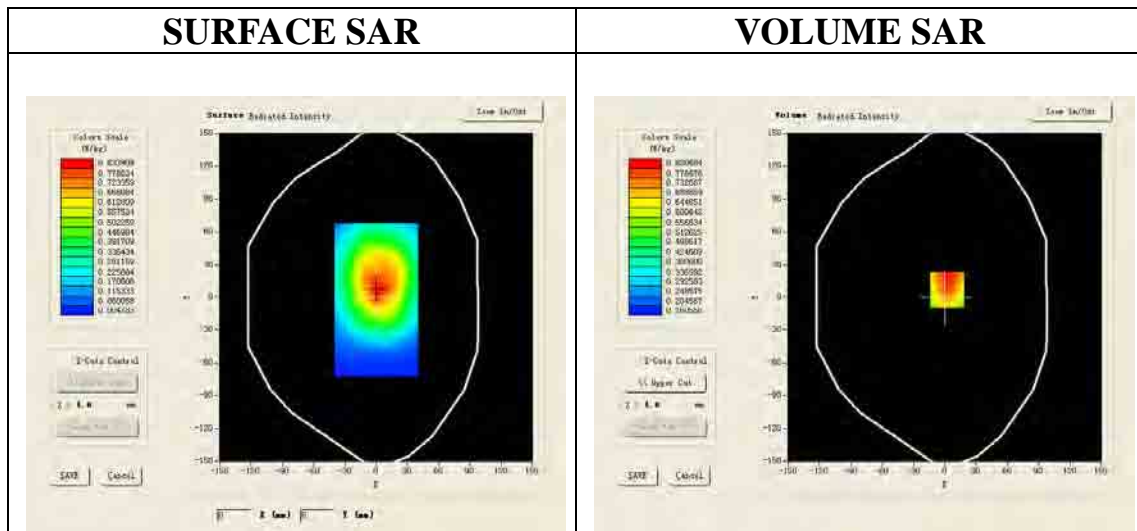

Maximum location: X=2.00, Y=7.00

SAR 10g (W/Kg)	0.595218
SAR 1g (W/Kg)	0.847825

Z (mm)	0.00	4.00	9.00	14.00	19.00
SAR (W/Kg)	0.0000	0.7859	0.5783	0.4296	0.3231

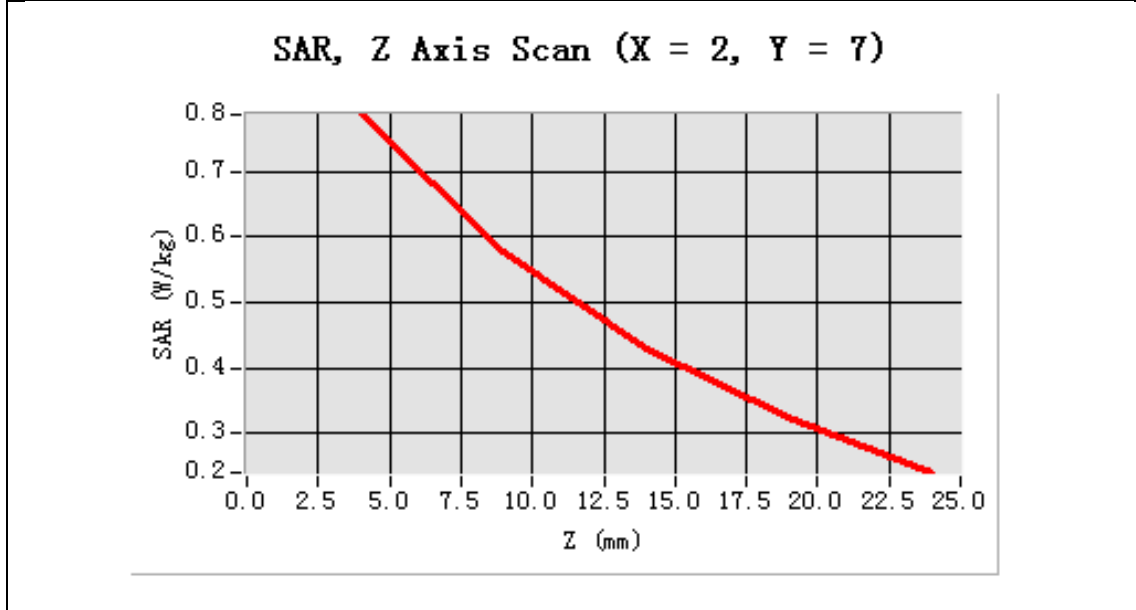

3D screen shot	Hot spot position
<p>A 3D perspective view of a grey, rectangular device. A small, localized area on the front face is highlighted with a color gradient from blue to red, indicating the position of the maximum SAR value.</p>	<p>A 2D heatmap visualization of the SAR distribution. It shows a circular region with a red center, transitioning through yellow and green to a blue outer boundary, representing the spatial extent and intensity of the electromagnetic field.</p>

Test Laboratory: AGC Lab  
WCDMA Band II High-Body-Towards Grounds (RMC)  
DUT: Axe II 3G; Type: Z402

Date: Jan.25,2014

Communication System: UMTS; Communication System Band: Band II UTRA/FDD ;Duty Cycle:1:1; ConvF=4.84  
Frequency: 1907.6 MHz; Medium parameters used:  $f = 1900$  MHz;  $\sigma=1.52$  mho/m;  $\epsilon_r =54.29$ ;  $\rho= 1000$  kg/m<sup>3</sup> ;  
Phantom section: Flat Section  
Ambient temperature (°C):21, Liquid temperature (°C):21

SATIMO Configuration:

- Probe: EP165; Calibrated: 01/31/2013
- Sensor-Surface: 4mm (Mechanical Surface Detection)
- Phantom: Flat Phantom; Type: Elliptical Phantom
- Measurement SW: OpenSAR V4\_02\_01

Configuration/ WCDMA band II High-Body-back/Area Scan: Measurement grid: dx=8mm, dy=8mm  
Configuration/ WCDMA band II High-Body-back/Zoom Scan: Measurement grid: dx=8mm, dy=8mm, dz=5mm;

Area Scan	surf_sam_plan.txt
ZoomScan	5x5x7,dx=8mm dy=8mm dz=5mm,Very fast
Phantom	Validation plane
Device Position	Body Back
Band	WCDMA band II
Channels	High
Signal	TDMA (Crest factor: 1.0)

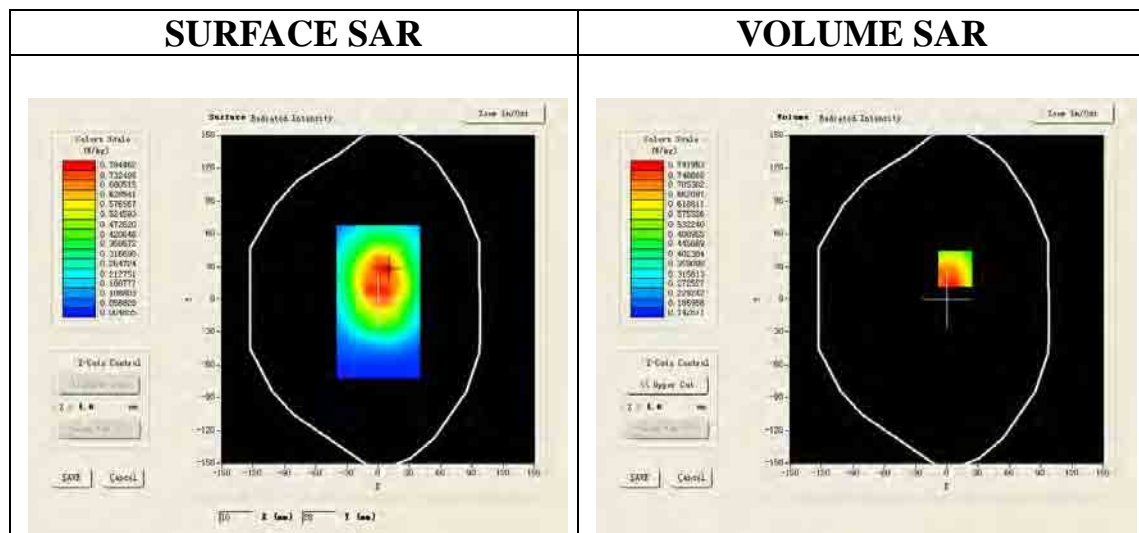

Maximum location: X=8.00, Y=28.00

SAR 10g (W/Kg)	0.564168
SAR 1g (W/Kg)	0.806524

Z (mm)	0.00	4.00	9.00	14.00	19.00
SAR (W/Kg)	0.0000	0.6854	0.5123	0.3861	0.2939

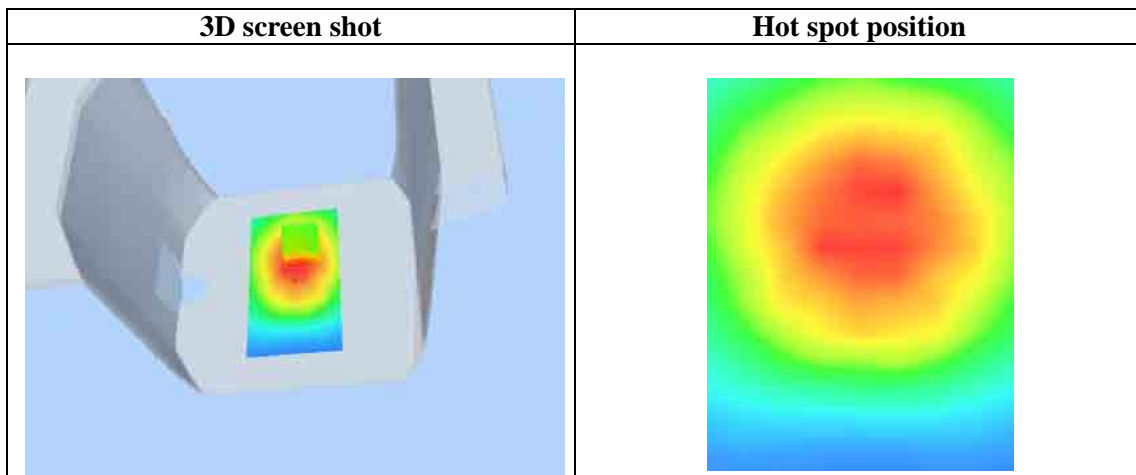
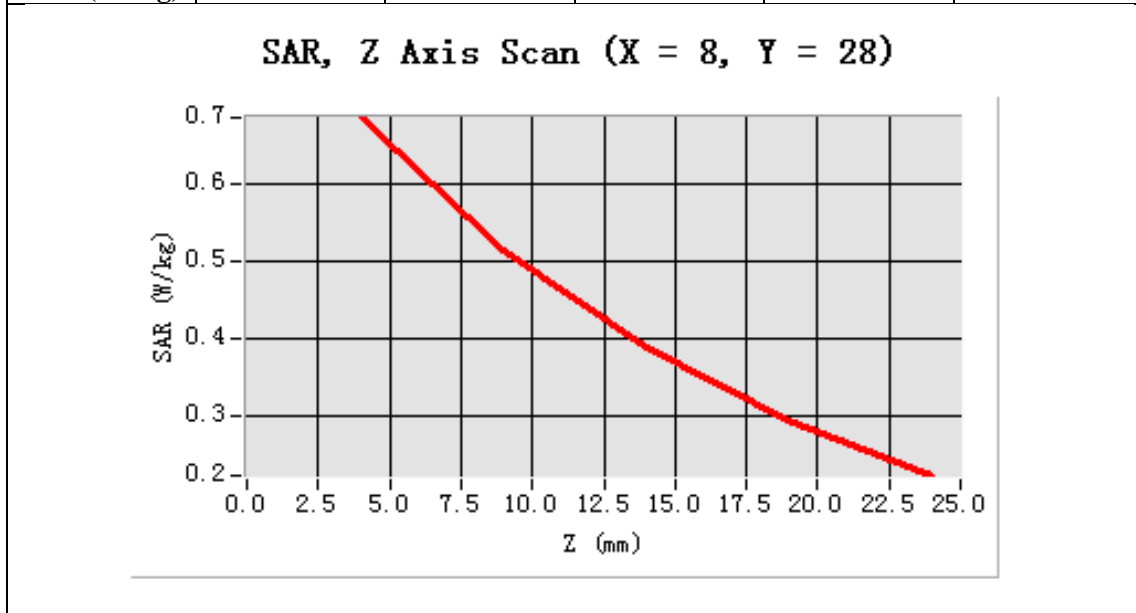

Test Laboratory: AGC Lab  
WCDMA Band II Mid-Body-Towards Phantom (RMC)  
DUT: Axe II 3G; Type: Z402

Date: Jan.25,2014

Communication System: UMTS; Communication System Band: Band II UTRA/FDD ;Duty Cycle:1:1; ConvF=4.84  
Frequency: 1880 MHz; Medium parameters used:  $f = 1900$  MHz;  $\sigma=1.53$  mho/m;  $\epsilon_r =53.76$ ;  $\rho= 1000$  kg/m<sup>3</sup> ;  
Phantom section: Flat Section  
Ambient temperature (°C):21, Liquid temperature (°C):21

SATIMO Configuration:

- Probe: EP165; Calibrated: 01/31/2013
- Sensor-Surface: 4mm (Mechanical Surface Detection)
- Phantom: Flat Phantom; Type: Elliptical Phantom
- Measurement SW: OpenSAR V4\_02\_01

Configuration/ WCDMA band II Mid-Body-Front/Area Scan: Measurement grid: dx=8mm, dy=8mm  
Configuration/ WCDMA band II Mid-Body-Front/Zoom Scan: Measurement grid: dx=8mm, dy=8mm, dz=5mm;

Area Scan	surf_sam_plan.txt
ZoomScan	5x5x7,dx=8mm dy=8mm dz=5mm,Very fast
Phantom	Validation plane
Device Position	Body Front
Band	WCDMA band II
Channels	Middle
Signal	TDMA (Crest factor: 1.0)

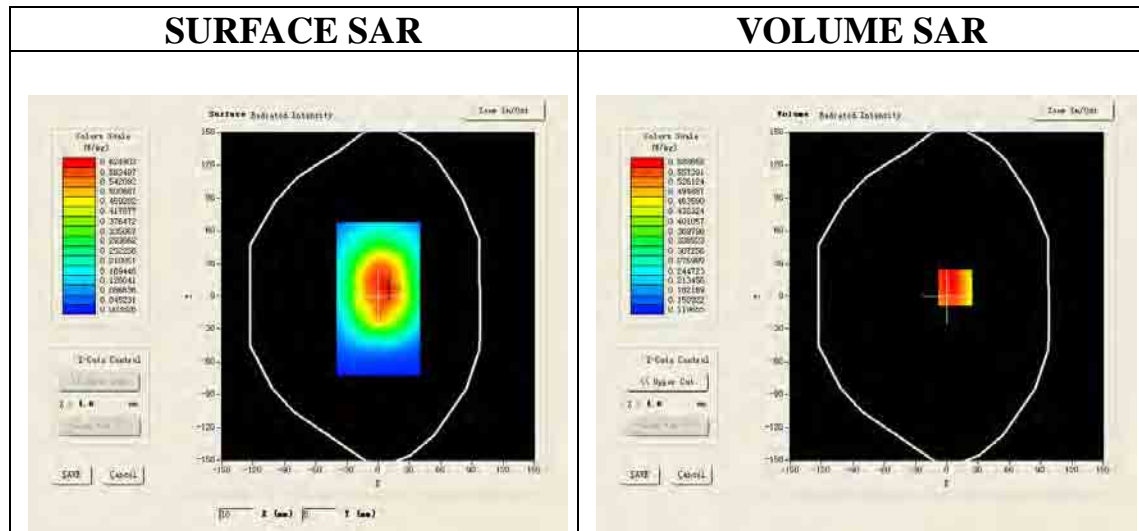

Maximum location: X=8.00, Y=8.00

SAR 10g (W/Kg)	0.443851
SAR 1g (W/Kg)	0.616417

Z (mm)	0.00	4.00	9.00	14.00	19.00
SAR (W/Kg)	0.0000	0.5796	0.4429	0.3325	0.2438

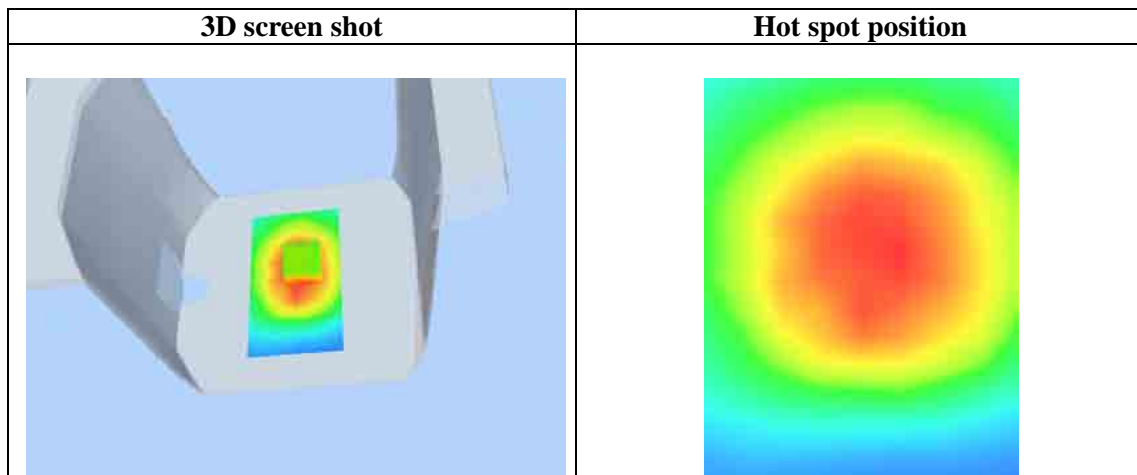
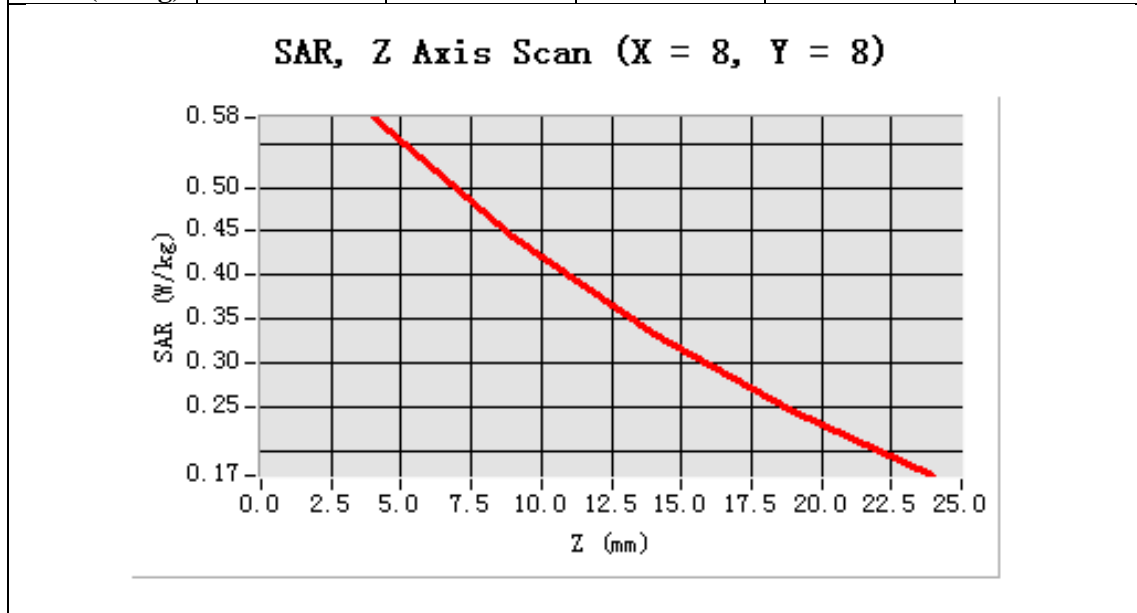



Test Laboratory: AGC Lab

Date: Jan.25,2014

WCDMA Band V Low-Touch-Left (RMC )

DUT: Axe II 3G; Type: Z402

Communication System: UMTS; Communication System Band: BAND V UTRA/FDD ; Duty Cycle:1: 1; Conv.F=5.30  
Frequency: 826.4 MHz; Medium parameters used: f = 835 MHz;  $\sigma=0.87$  mho/m;  $\epsilon_r=41.21$ ;  $\rho=1000$  kg/m<sup>3</sup> ;  
Phantom section: Left Section  
Ambient temperature (°C): 21, Liquid temperature (°C): 21

SATIMO Configuration:

- Probe: EP165; Calibrated: 01/31/2013
- Sensor-Surface: 4mm (Mechanical Surface Detection)
- Phantom: Flat Phantom; Type: Elliptical Phantom
- Measurement SW: OpenSAR V4\_02\_01

Configuration/ WCDMA Band V Low-Touch-Left/Area Scan (6x8x1): Measurement grid: dx=8mm, dy=8mm  
Configuration/ WCDMA Band V Low-Touch-Left/Zoom Scan (5x5x7)/Cube 0: Measurement grid: dx=8mm, dy=8mm, dz=5mm

Area Scan	sam_direct_droit2_surf8mm.txt
ZoomScan	5x5x7,dx=8mm dy=8mm dz=5mm,Very fast
Phantom	Left head
Device Position	Cheek
Band	WCDMA Band V
Channels	Low
Signal	TDMA (Crest factor: 1.0)

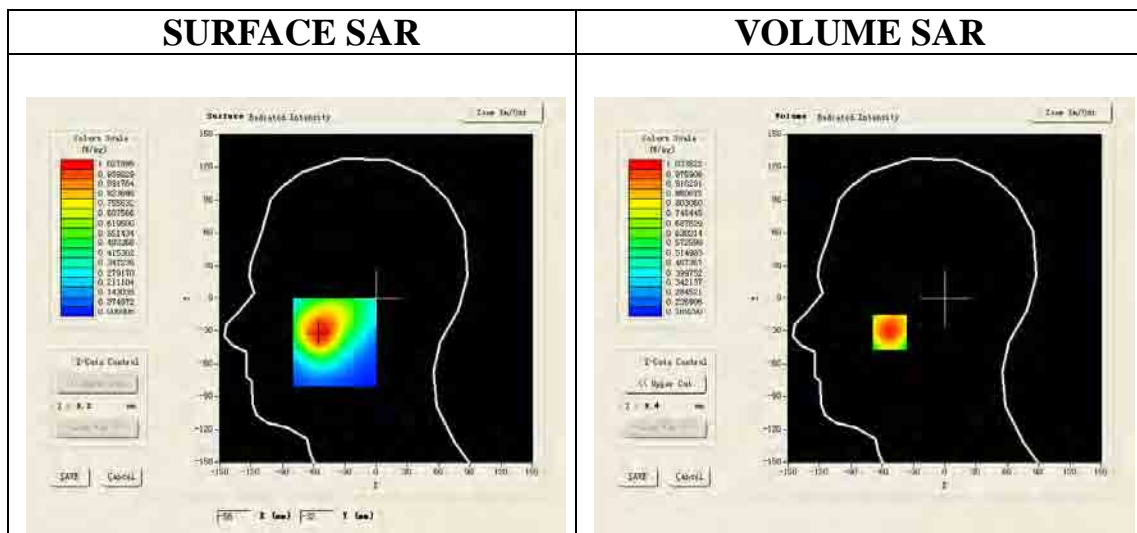

Maximum location: X=-53.00, Y=-31.00

SAR 10g (W/Kg)	0.703017
SAR 1g (W/Kg)	0.989894

Z (mm)	0.00	4.00	9.00	14.00	19.00
SAR (W/Kg)	0.0000	1.0335	0.7941	0.6075	0.4618

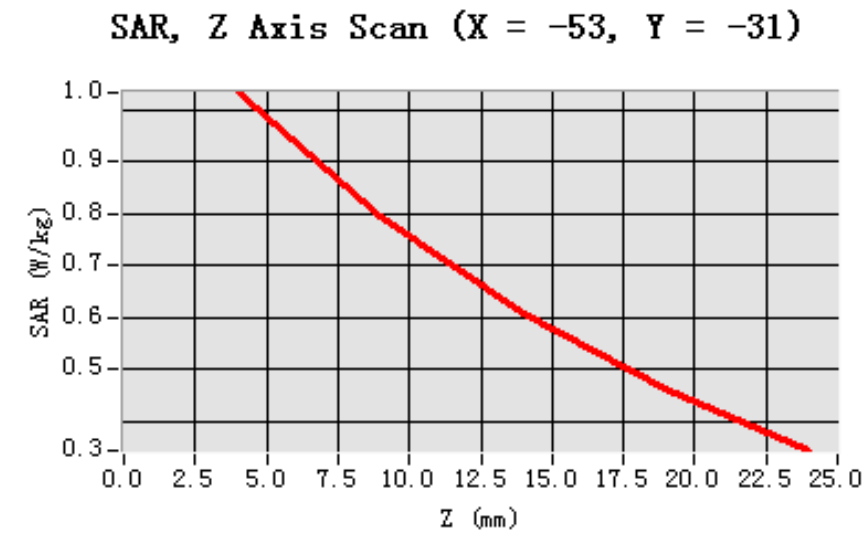

3D screen shot	Hot spot position
<p>A 3D rendering of a human head model. A small, localized area on the forehead is highlighted with a color gradient from blue to red, indicating a hot spot of high SAR exposure.</p>	<p>A 2D heatmap visualization of the hot spot. The core of the hot spot is red, transitioning through yellow and green to blue at the periphery, representing the spatial distribution of SAR exposure.</p>

Test Laboratory: AGC Lab

Date: Jan.25,2014

WCDMA Band V Mid-Touch-Left (RMC )

DUT: Axe II 3G; Type: Z402

Communication System: UMTS; Communication System Band: BAND V UTRA/FDD ; Duty Cycle:1: 1; Conv.F=5.30  
Frequency: 835 MHz; Medium parameters used:  $f = 835$  MHz;  $\sigma=0.92$  mho/m;  $\epsilon_r =41.53$ ;  $\rho= 1000$  kg/m<sup>3</sup> ;  
Phantom section: Left Section  
Ambient temperature (°C): 21, Liquid temperature (°C): 21

SATIMO Configuration:

- Probe: EP165; Calibrated: 01/31/2013
- Sensor-Surface: 4mm (Mechanical Surface Detection)
- Phantom: Flat Phantom; Type: Elliptical Phantom
- Measurement SW: OpenSAR V4\_02\_01

Configuration/ WCDMA Band V Mid-Touch-Left/Area Scan (6x8x1): Measurement grid: dx=8mm, dy=8mm  
Configuration/ WCDMA Band V Mid-Touch-Left/Zoom Scan (5x5x7)/Cube 0: Measurement grid: dx=8mm, dy=8mm, dz=5mm

<b>Area Scan</b>	sam_direct_droit2_surf8mm.txt
<b>ZoomScan</b>	5x5x7,dx=8mm dy=8mm dz=5mm,Very fast
<b>Phantom</b>	Left head
<b>Device Position</b>	Cheek
<b>Band</b>	WCDMA Band V
<b>Channels</b>	Middle
<b>Signal</b>	TDMA (Crest factor: 1.0)

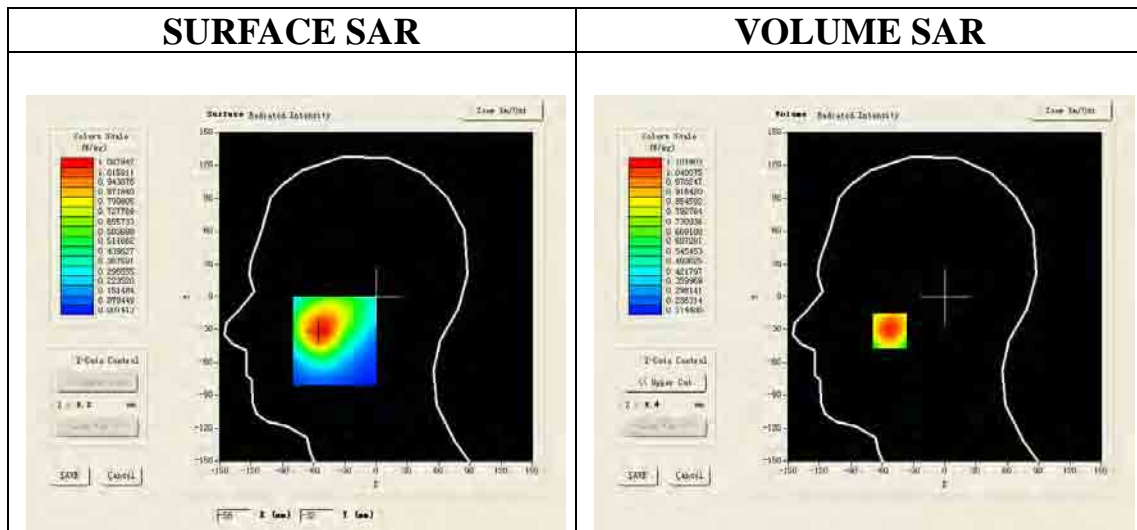

Maximum location: X=-53.00, Y=-31.00

<b>SAR 10g (W/Kg)</b>	0.743043
<b>SAR 1g (W/Kg)</b>	1.054481

Z (mm)	0.00	4.00	9.00	14.00	19.00
SAR (W/Kg)	0.0000	1.1019	0.8372	0.6358	0.4821

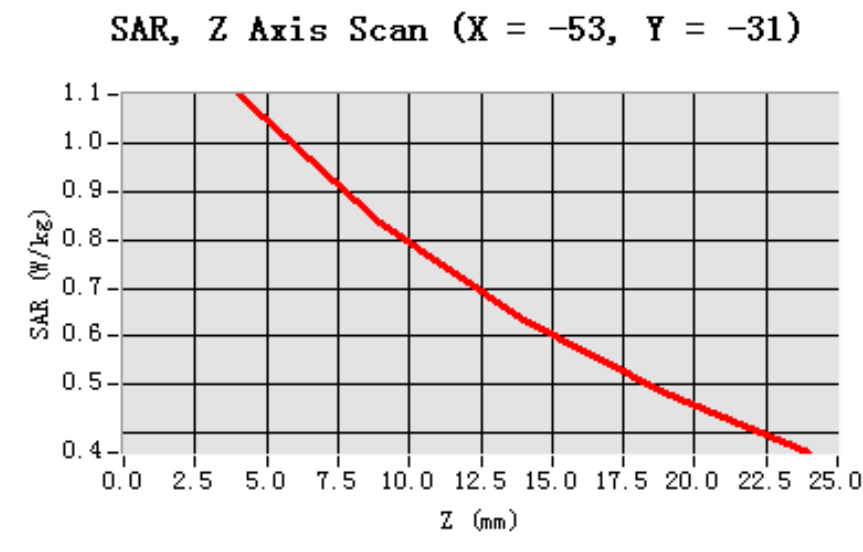

3D screen shot	Hot spot position
<p>A 3D rendering of a human head and neck. A small, localized area on the face is highlighted with a color gradient from blue to red, indicating the location of the maximum SAR (hot spot).</p>	<p>A 2D heatmap visualization of the hot spot. The color scale ranges from blue (low SAR) to red (high SAR), showing a central region of high intensity surrounded by concentric rings of decreasing intensity.</p>

Test Laboratory: AGC Lab

Date: Jan.25,2014

WCDMA Band V High-Touch-Left (RMC )

DUT: Axe II 3G; Type: Z402

Communication System: UMTS; Communication System Band: BAND V UTRA/FDD ; Duty Cycle:1: 1; Conv.F=5.30  
Frequency: 846.6 MHz; Medium parameters used:  $f = 835$  MHz;  $\sigma=0.88$  mho/m;  $\epsilon_r = 40.87$ ;  $\rho = 1000$  kg/m<sup>3</sup> ;  
Phantom section: Left Section  
Ambient temperature (°C): 21, Liquid temperature (°C): 21

SATIMO Configuration:

- Probe: EP165; Calibrated: 01/31/2013
- Sensor-Surface: 4mm (Mechanical Surface Detection)
- Phantom: Flat Phantom; Type: Elliptical Phantom
- Measurement SW: OpenSAR V4\_02\_01

Configuration/ WCDMA Band V High-Touch-Left/Area Scan (6x8x1): Measurement grid: dx=8mm, dy=8mm  
Configuration/ WCDMA Band V High-Touch-Left/Zoom Scan (5x5x7)/Cube 0: Measurement grid: dx=8mm, dy=8mm, dz=5mm

<b>Area Scan</b>	sam_direct_droit2_surf8mm.txt
<b>ZoomScan</b>	5x5x7,dx=8mm dy=8mm dz=5mm,Very fast
<b>Phantom</b>	Left head
<b>Device Position</b>	Cheek
<b>Band</b>	WCDMA Band V
<b>Channels</b>	High
<b>Signal</b>	TDMA (Crest factor: 1.0)

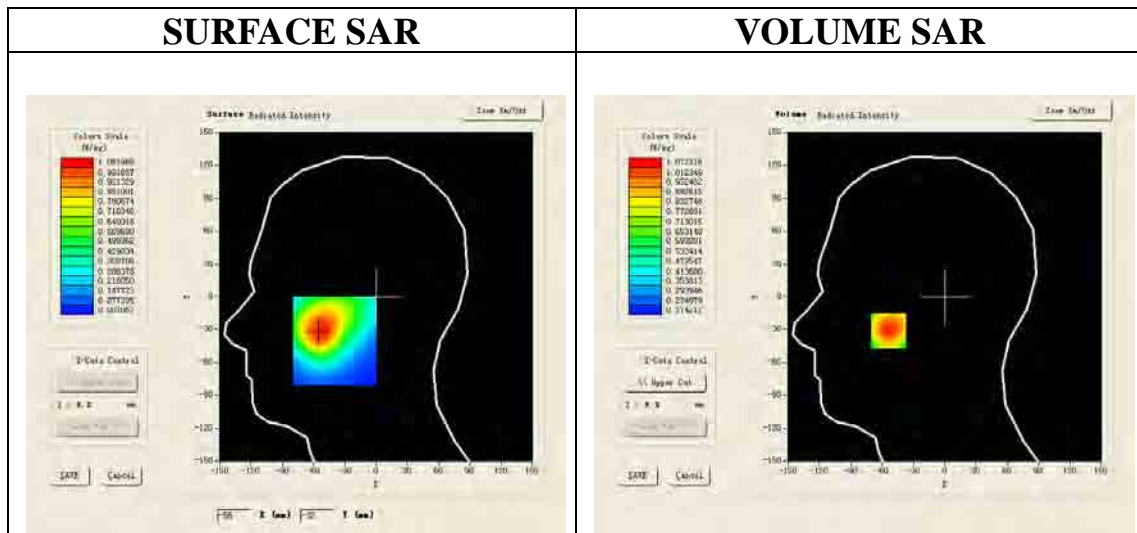

Maximum location: X=-54.00, Y=-31.00

<b>SAR 10g (W/Kg)</b>	0.725284
<b>SAR 1g (W/Kg)</b>	1.026148

Z (mm)	0.00	4.00	9.00	14.00	19.00
SAR (W/Kg)	0.0000	1.0722	0.8156	0.6210	0.4731

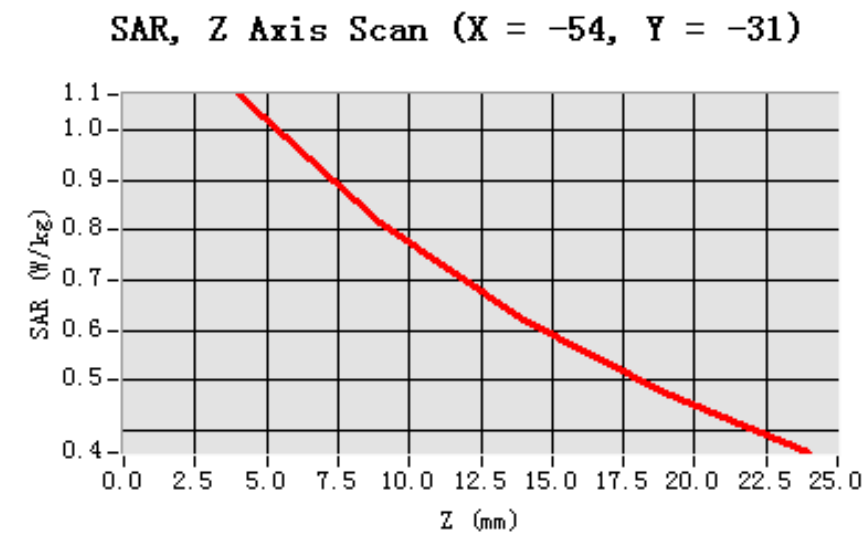

3D screen shot	Hot spot position
<p>A 3D rendering of a human head model. A small, localized area on the forehead is highlighted with a color gradient from blue to red, indicating a hot spot of high SAR exposure.</p>	<p>A 2D heatmap showing the spatial distribution of SAR exposure. The color scale ranges from blue (low SAR) to red (high SAR). The highest intensity is concentrated in the center of the forehead area, corresponding to the hot spot shown in the 3D model.</p>

Test Laboratory: AGC Lab  
WCDMA Band V Mid-Tilt-Left (RMC)  
DUT: Axe II 3G; Type: Z402

Date: Jan.25,2014

Communication System: UMTS; Communication System Band: BAND V UTRA/FDD ; Duty Cycle:1: 1; Conv.F=5.30  
Frequency: 835 MHz; Medium parameters used:  $f = 835$  MHz;  $\sigma=0.92$  mho/m;  $\epsilon_r =41.53$ ;  $\rho= 1000$  kg/m<sup>3</sup> ;  
Phantom section: Left Section  
Ambient temperature (°C): 21, Liquid temperature (°C): 21

SATIMO Configuration:

- Probe: EP165; Calibrated: 01/31/2013
- Sensor-Surface: 4mm (Mechanical Surface Detection)
- Phantom: Flat Phantom; Type: Elliptical Phantom
- Measurement SW: OpenSAR V4\_02\_01

Configuration/ WCDMA Band V Mid-Tilt-Left/Area Scan (6x8x1): Measurement grid: dx=8mm, dy=8mm  
Configuration/ WCDMA Band V Mid-Tilt-Left/Zoom Scan (5x5x7)/Cube 0: Measurement grid: dx=8mm, dy=8mm, dz=5mm;

Area Scan	sam_direct_droit2_surf8mm.txt
ZoomScan	5x5x7,dx=8mm dy=8mm dz=5mm,Very fast
Phantom	Left head
Device Position	Tilt
Band	WCDMA Band V
Channels	Middle
Signal	TDMA (Crest factor: 1.0)

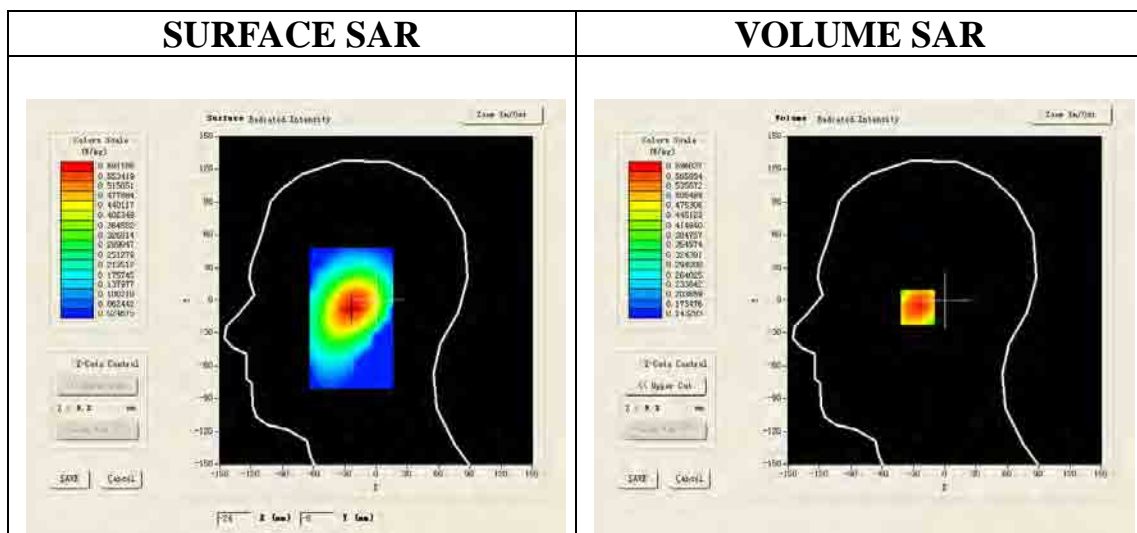

Maximum location: X=-23.00, Y=-6.00

SAR 10g (W/Kg)	0.425586
SAR 1g (W/Kg)	0.573452

Z (mm)	0.00	4.00	9.00	14.00	19.00
SAR (W/Kg)	0.0000	0.5960	0.4673	0.3692	0.2941

**SAR, Z Axis Scan (X = -23, Y = -6)**

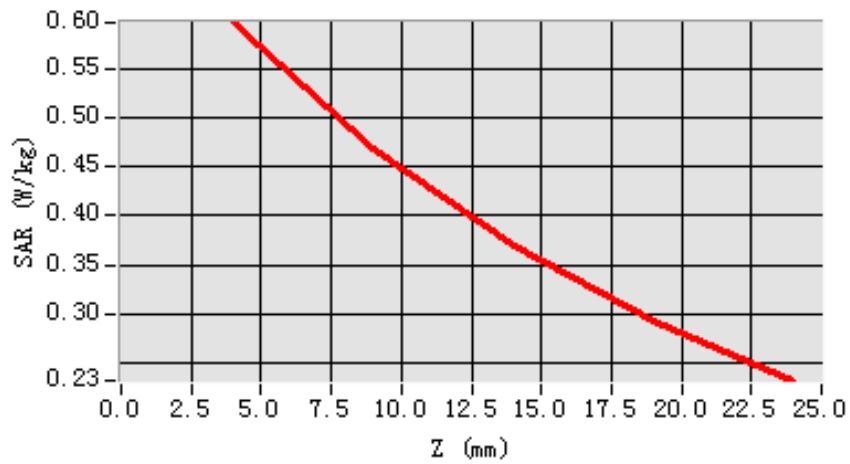

**3D screen shot**

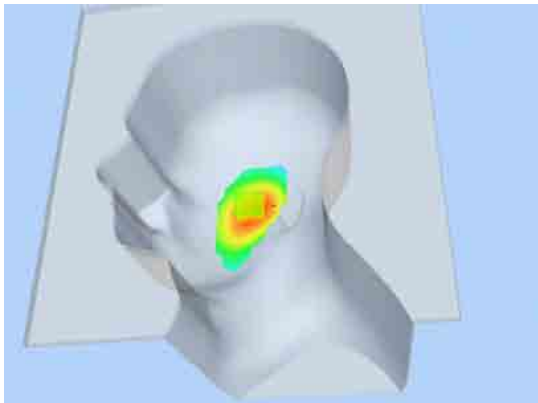

**Hot spot position**

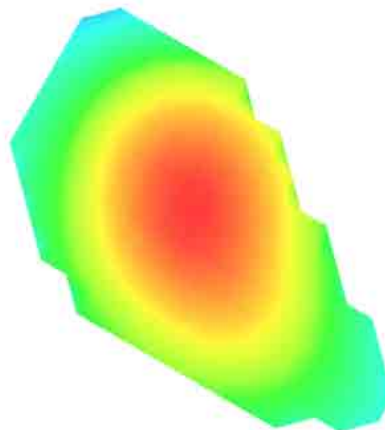



Test Laboratory: AGC Lab

Date: Jan.25,2014

WCDMA Band V Low-Touch-Right (RMC)

DUT: Axe II 3G; Type: Z402

Communication System: UMTS; Communication System Band: BAND V UTRA/FDD ; Duty Cycle:1: 1; Conv.F=5.30  
Frequency: 826.4 MHz; Medium parameters used:  $f = 835$  MHz;  $\sigma=0.87$  mho/m;  $\epsilon_r=41.21$ ;  $\rho= 1000$  kg/m<sup>3</sup> ;  
Phantom section: Right Section  
Ambient temperature (°C): 21, Liquid temperature (°C): 21

SATIMO Configuration:

- Probe: EP165; Calibrated: 01/31/2013
- Sensor-Surface: 4mm (Mechanical Surface Detection)
- Phantom: Flat Phantom; Type: Elliptical Phantom
- Measurement SW: OpenSAR V4\_02\_01

Configuration/ WCDMA Band V Low-Touch-Right/Area Scan: Measurement grid: dx=8mm, dy=8mm  
Configuration/ WCDMA Band V Low-Touch-Right/Zoom Scan: Measurement grid: dx=8mm, dy=8mm, dz=5mm;

<b>Area Scan</b>	sam_direct_droit2_surf8mm.txt
<b>ZoomScan</b>	5x5x7,dx=8mm dy=8mm dz=5mm,Very fast
<b>Phantom</b>	Right head
<b>Device Position</b>	Cheek
<b>Band</b>	WCDMA Band V
<b>Channels</b>	Low
<b>Signal</b>	TDMA (Crest factor: 1.0)

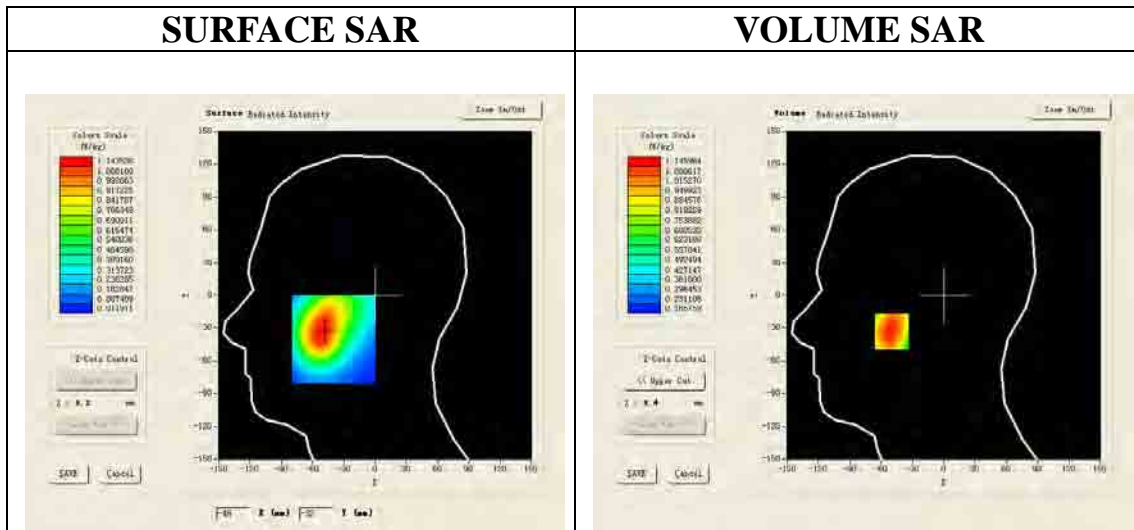

**Maximum location: X=-50.00, Y=-33.00**

<b>SAR 10g (W/Kg)</b>	0.760706
<b>SAR 1g (W/Kg)</b>	1.098817

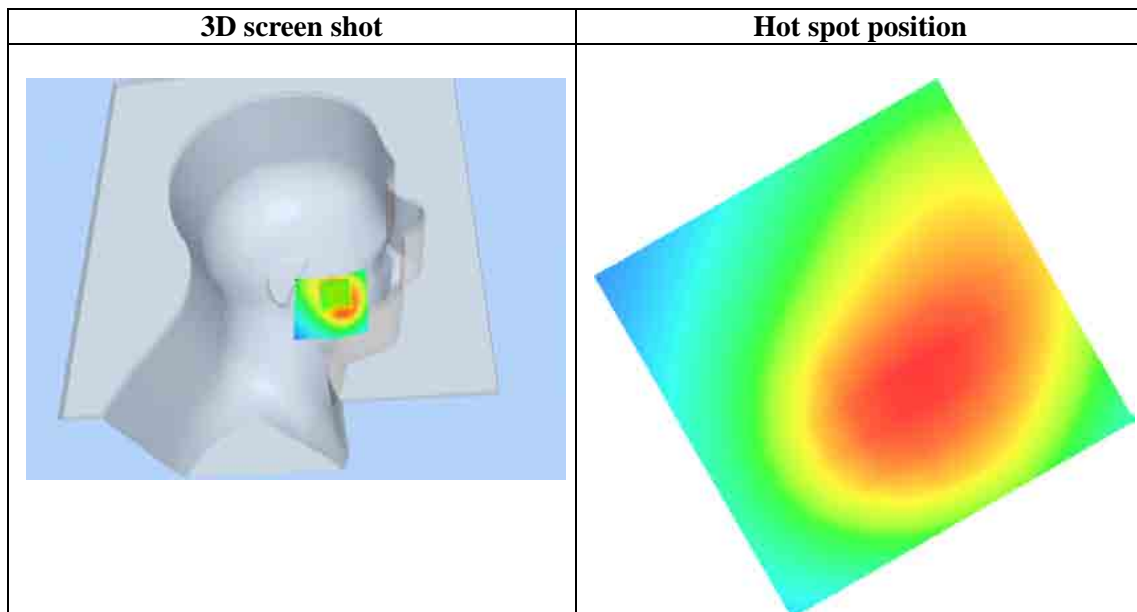
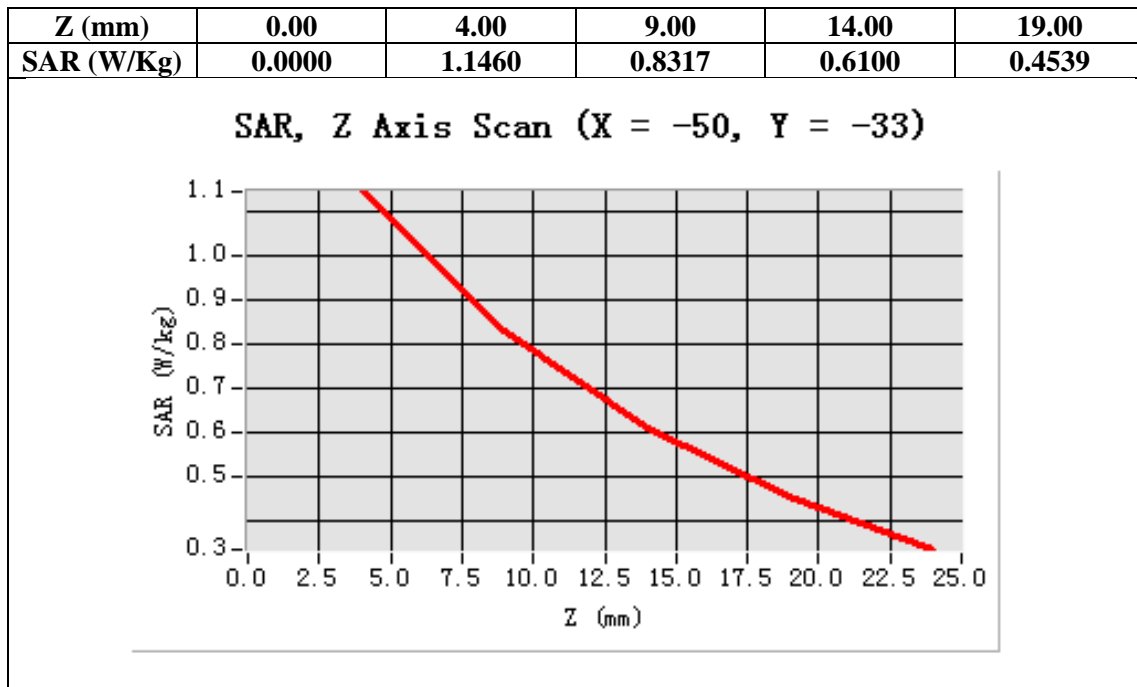

Test Laboratory: AGC Lab

Date: Jan.25,2014

WCDMA Band V Mid- Touch-Right (RMC)

DUT: Axe II 3G; Type: Z402

Communication System: UMTS; Communication System Band: BAND V UTRA/FDD ; Duty Cycle:1: 1; Conv.F=5.30  
Frequency: 835 MHz; Medium parameters used:  $f = 835$  MHz;  $\sigma=0.92$  mho/m;  $\epsilon_r =41.53$ ;  $\rho= 1000$  kg/m<sup>3</sup> ;  
Phantom section: Right Section  
Ambient temperature (°C): 21, Liquid temperature (°C): 21

SATIMO Configuration:

- Probe: EP165; Calibrated: 01/31/2013
- Sensor-Surface: 4mm (Mechanical Surface Detection)
- Phantom: Flat Phantom; Type: Elliptical Phantom
- Measurement SW: OpenSAR V4\_02\_01

Configuration/ WCDMA Band V Mid-Touch-Right/Area Scan: Measurement grid: dx=8mm, dy=8mm  
Configuration/ WCDMA Band V Mid-Touch-Right/Zoom Scan: Measurement grid: dx=8mm, dy=8mm, dz=5mm;

<b>Area Scan</b>	sam_direct_droit2_surf8mm.txt
<b>ZoomScan</b>	5x5x7,dx=8mm dy=8mm dz=5mm,Very fast
<b>Phantom</b>	Right head
<b>Device Position</b>	Cheek
<b>Band</b>	WCDMA Band V
<b>Channels</b>	Middle
<b>Signal</b>	TDMA (Crest factor: 1.0)

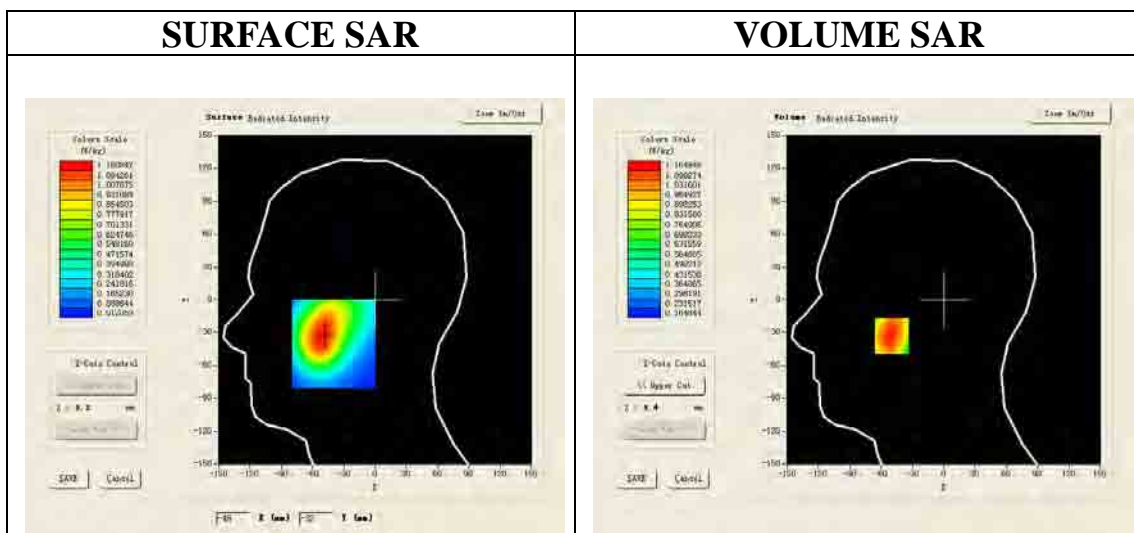

Maximum location: X=-50.00, Y=-33.00

<b>SAR 10g (W/Kg)</b>	0.770767
<b>SAR 1g (W/Kg)</b>	1.116801

Z (mm)	0.00	4.00	9.00	14.00	19.00
SAR (W/Kg)	0.0000	1.1649	0.8434	0.6168	0.4573

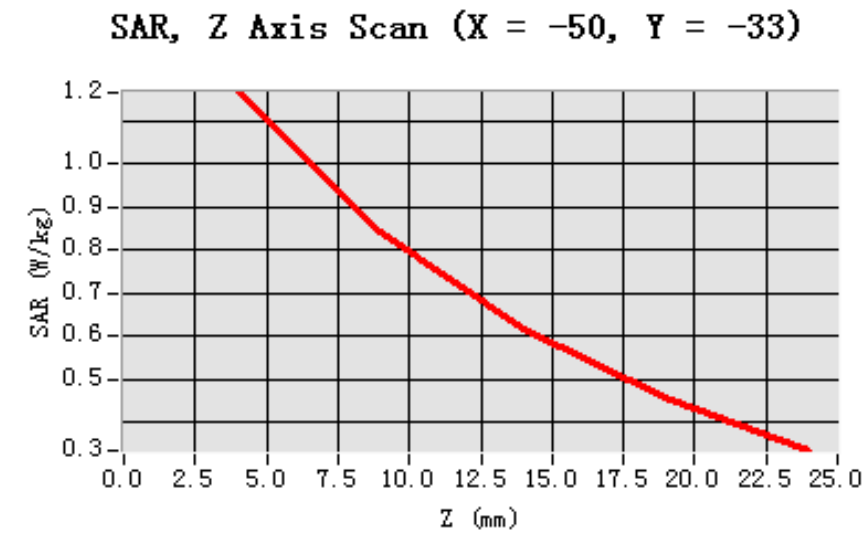

3D screen shot	Hot spot position
<p>A 3D rendering of a human head model. A small, localized area on the ear is highlighted with a color gradient from blue to red, indicating the position of the maximum SAR (hot spot).</p>	<p>A 2D heatmap visualization of the hot spot. The color scale ranges from blue (low SAR) to red (high SAR). The highest SAR region is a red core, which transitions through yellow and green to blue at the periphery.</p>

Test Laboratory: AGC Lab

Date: Jan.25,2014

WCDMA Band V High-Touch-Right (RMC)

DUT: Axe II 3G; Type: Z402

Communication System: UMTS; Communication System Band: BAND V UTRA/FDD ; Duty Cycle:1: 1; Conv.F=5.30  
Frequency: 846.6 MHz; Medium parameters used:  $f = 835$  MHz;  $\sigma=0.88$  mho/m;  $\epsilon_r = 40.87$ ;  $\rho = 1000$  kg/m<sup>3</sup> ;  
Phantom section: Right Section  
Ambient temperature (°C): 21, Liquid temperature (°C): 21

SATIMO Configuration:

- Probe: EP165; Calibrated: 01/31/2013
- Sensor-Surface: 4mm (Mechanical Surface Detection)
- Phantom: Flat Phantom; Type: Elliptical Phantom
- Measurement SW: OpenSAR V4\_02\_01

Configuration/ WCDMA Band V High-Touch-Right/Area Scan: Measurement grid: dx=8mm, dy=8mm  
Configuration/ WCDMA Band V High-Touch-Right/Zoom Scan: Measurement grid: dx=8mm, dy=8mm, dz=5mm;

Area Scan	sam_direct_droit2_surf8mm.txt
ZoomScan	5x5x7,dx=8mm dy=8mm dz=5mm,Very fast
Phantom	Right head
Device Position	Cheek
Band	WCDMA Band V
Channels	High
Signal	TDMA (Crest factor: 1.0)

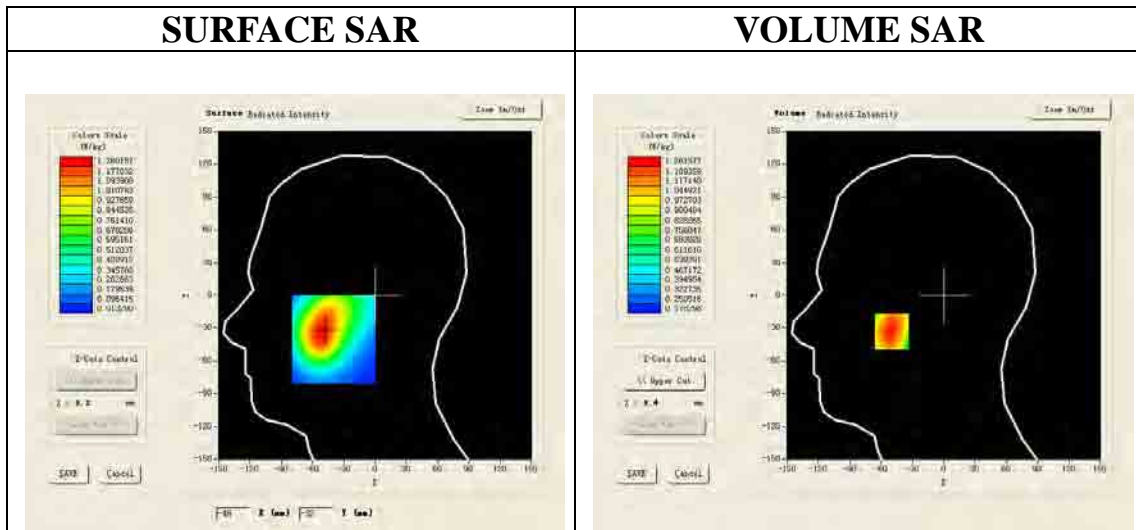

Maximum location: X=-50.00, Y=-33.00

SAR 10g (W/Kg)	0.831567
SAR 1g (W/Kg)	1.208121

Z (mm)	0.00	4.00	9.00	14.00	19.00
SAR (W/Kg)	0.0000	1.2616	0.9133	0.6664	0.4915

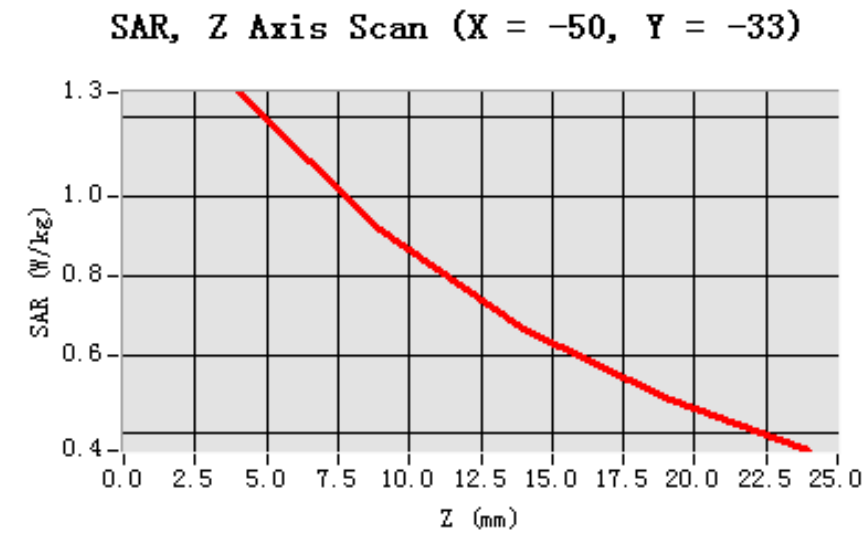

3D screen shot	Hot spot position
<p>A 3D rendering of a human head in profile, facing right. A small, rectangular area on the ear is highlighted with a color gradient from blue to red, indicating the location of the hot spot.</p>	<p>A 2D heatmap showing the spatial distribution of the hot spot. The color gradient transitions from blue (low SAR) to green, yellow, and red (high SAR), with the highest intensity (red) concentrated in the center of the hot spot area.</p>

Test Laboratory: AGC Lab

Date: Jan.25,2014

WCDMA Band V Mid-Tilt-Right (RMC)

DUT: Axe II 3G; Type: Z402

Communication System: UMTS; Communication System Band: BAND V UTRA/FDD ; Duty Cycle:1: 1; Conv.F=5.30  
Frequency: 835 MHz; Medium parameters used:  $f = 835$  MHz;  $\sigma=0.92$  mho/m;  $\epsilon_r=41.53$ ;  $\rho= 1000$  kg/m<sup>3</sup> ;  
Phantom section: Right Section  
Ambient temperature (°C): 21, Liquid temperature (°C): 21

SATIMO Configuration:

- Probe: EP165; Calibrated: 01/31/2013
- Sensor-Surface: 4mm (Mechanical Surface Detection)
- Phantom: Flat Phantom; Type: Elliptical Phantom
- Measurement SW: OpenSAR V4\_02\_01

Configuration/ WCDMA Band V Mid-Tilt-Right/Area Scan: Measurement grid: dx=8mm, dy=8mm  
Configuration/ WCDMA Band V Mid-Tilt-Right/Zoom Scan: Measurement grid: dx=8mm, dy=8mm, dz=5mm;

Area Scan	sam_direct_droit2_surf8mm.txt
Zoom Scan	5x5x7,dx=8mm dy=8mm dz=5mm,Very fast
Phantom	Right head
Device Position	Tilt
Band	WCDMA Band V
Channels	Middle
Signal	TDMA (Crest factor: 1.0)

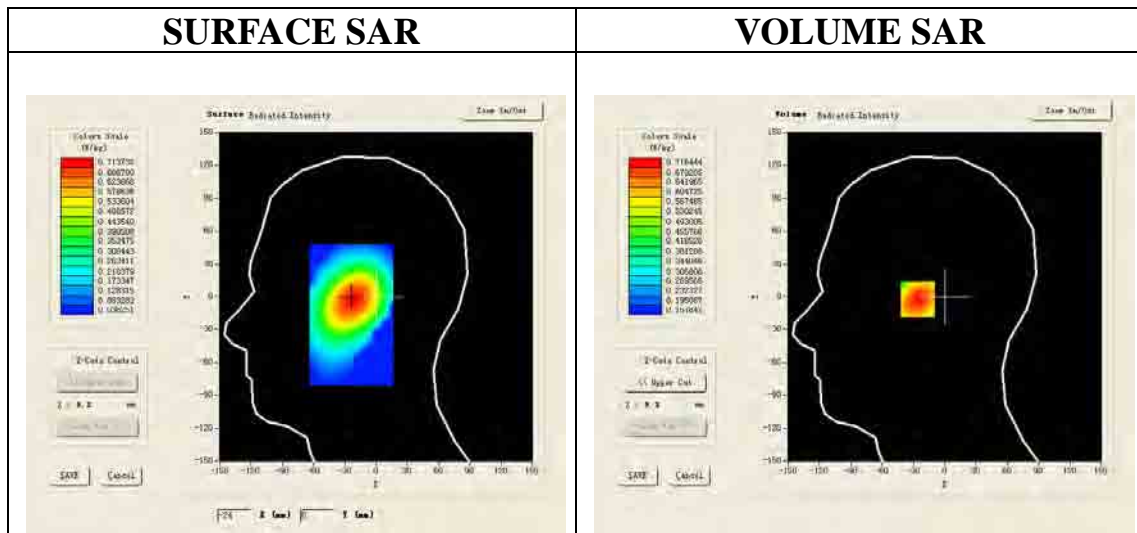

Maximum location: X=-23.00, Y=-2.00

SAR 10g (W/Kg)	0.509762
SAR 1g (W/Kg)	0.690002

Z (mm)	0.00	4.00	9.00	14.00	19.00
SAR (W/Kg)	0.0000	0.7164	0.5543	0.4354	0.3480

**SAR, Z Axis Scan (X = -23, Y = -2)**

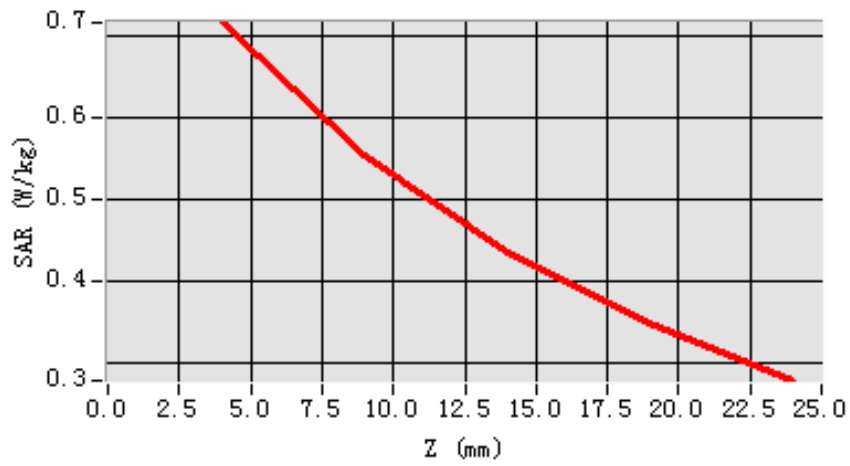

**3D screen shot**

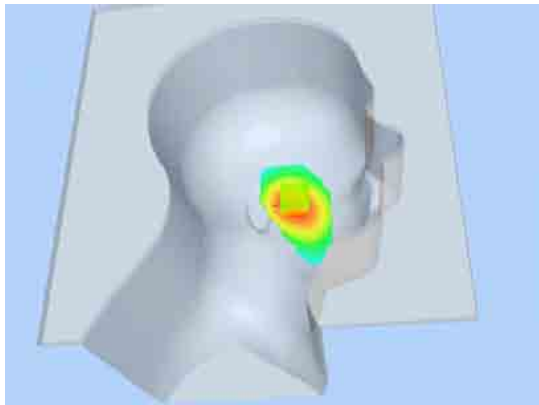

**Hot spot position**

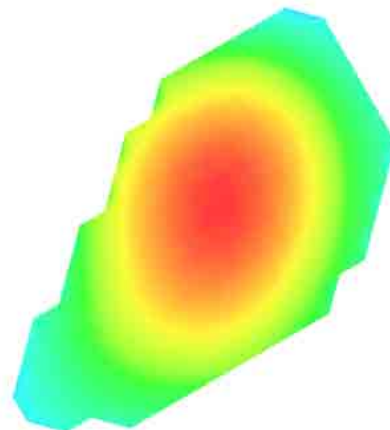



Test Laboratory: AGC Lab

Date: Jan.25,2014

WCDMA Band V Low-Body-Towards Grounds (RMC)

DUT: Axe II 3G; Type: Z402

Communication System: UMTS; Communication System Band: BAND V UTRA/FDD; Duty Cycle:1: 1; Conv.F=5.46  
Frequency: 826.4 MHz; Medium parameters used:  $f = 835$  MHz;  $\sigma=0.95$  mho/m;  $\epsilon_r = 54.88$ ;  $\rho = 1000$  kg/m<sup>3</sup> ;  
Phantom section: Flat Section  
Ambient temperature (°C):21, Liquid temperature (°C):21

SATIMO Configuration:

- Probe: EP165; Calibrated: 01/31/2013
- Sensor-Surface: 4mm (Mechanical Surface Detection)
- Phantom: Flat Phantom; Type: Elliptical Phantom
- Measurement SW: OpenSAR V4\_02\_01

Configuration/ WCDMA Band V Low-Body-Back/Area Scan (6x8x1): Measurement grid: dx=8mm, dy=8mm  
Configuration/ WCDMA Band V Low-Body-Back/Zoom Scan (5x5x7)/Cube 0: Measurement grid:  
dx=8mm,dy=8mm, dz=5mm;

Area Scan	surf_sam_plan.txt
ZoomScan	5x5x7,dx=8mm dy=8mm dz=5mm,Very fast
Phantom	Validation plane
Device Position	Body Back
Band	WCDMA Band V
Channels	Low
Signal	TDMA (Crest factor: 1.0)

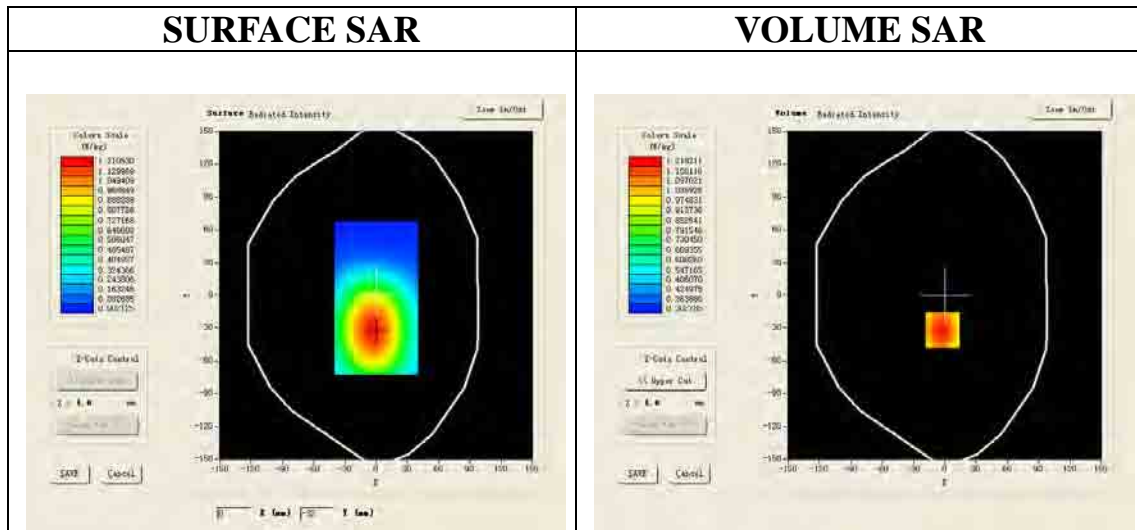

Maximum location: X=-2.00, Y=-32.00

SAR 10g (W/Kg)	0.854478
SAR 1g (W/Kg)	1.174161

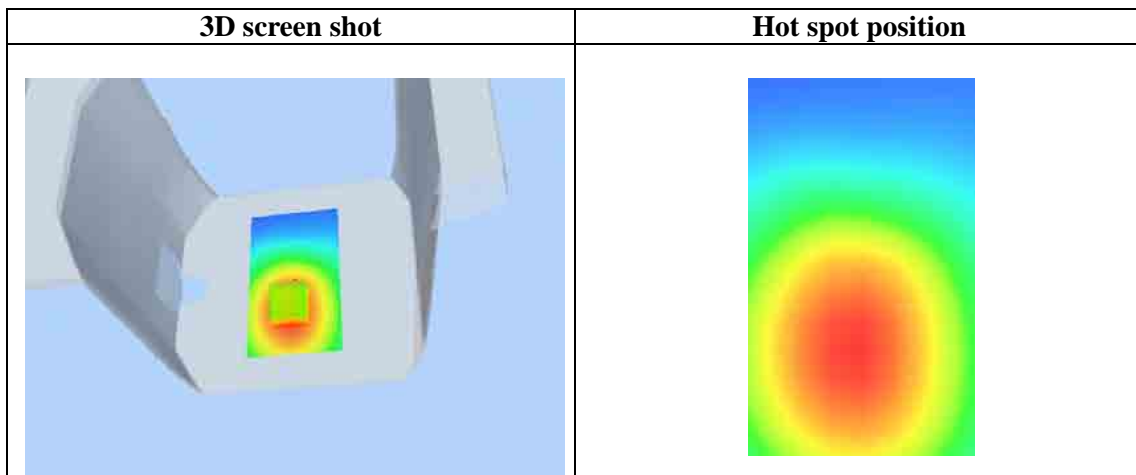
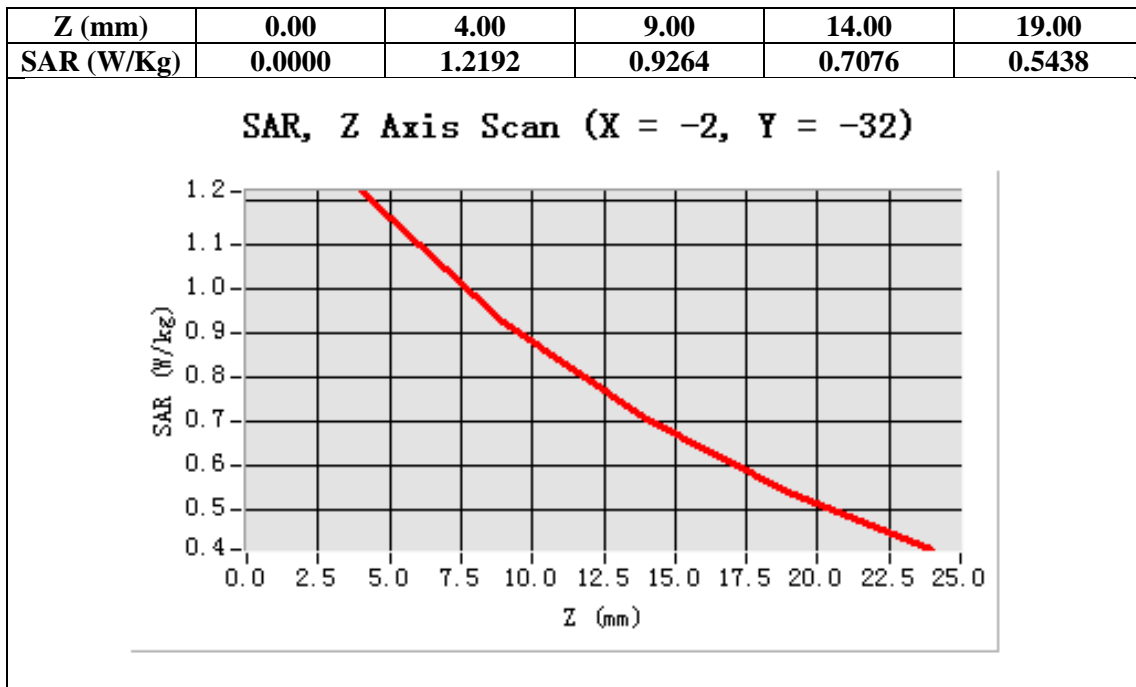

Test Laboratory: AGC Lab

Date: Jan.25,2014

WCDMA Band V Mid-Body-Towards Grounds (RMC)

DUT: Axe II 3G; Type: Z402

Communication System: UMTS; Communication System Band: BAND V UTRA/FDD; Duty Cycle:1: 1; Conv.F=5.46  
Frequency: 835 MHz; Medium parameters used:  $f = 835$  MHz;  $\sigma=0.96$  mho/m;  $\epsilon_r =55.02$ ;  $\rho= 1000$  kg/m<sup>3</sup> ;  
Phantom section: Flat Section  
Ambient temperature (°C):21, Liquid temperature (°C):21

SATIMO Configuration:

- Probe: EP165; Calibrated: 01/31/2013
- Sensor-Surface: 4mm (Mechanical Surface Detection)
- Phantom: Flat Phantom; Type: Elliptical Phantom
- Measurement SW: OpenSAR V4\_02\_01

Configuration/ WCDMA Band V Mid-Body-Back/Area Scan (6x8x1): Measurement grid: dx=8mm, dy=8mm  
Configuration/ WCDMA Band V Mid-Body-Back/Zoom Scan (5x5x7)/Cube 0: Measurement grid:  
dx=8mm,dy=8mm, dz=5mm;

Area Scan	surf_sam_plan.txt
ZoomScan	5x5x7,dx=8mm dy=8mm dz=5mm,Very fast
Phantom	Validation plane
Device Position	Body Back
Band	WCDMA Band V
Channels	Middle
Signal	TDMA (Crest factor: 1.0)

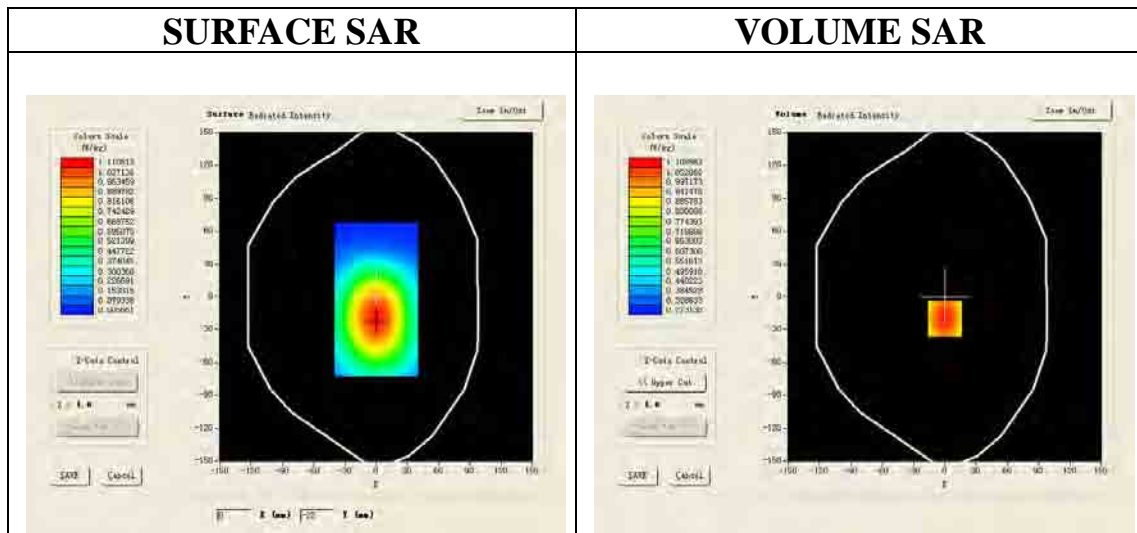

Maximum location: X=0.00, Y=-20.00

SAR 10g (W/Kg)	0.774887
SAR 1g (W/Kg)	1.066642

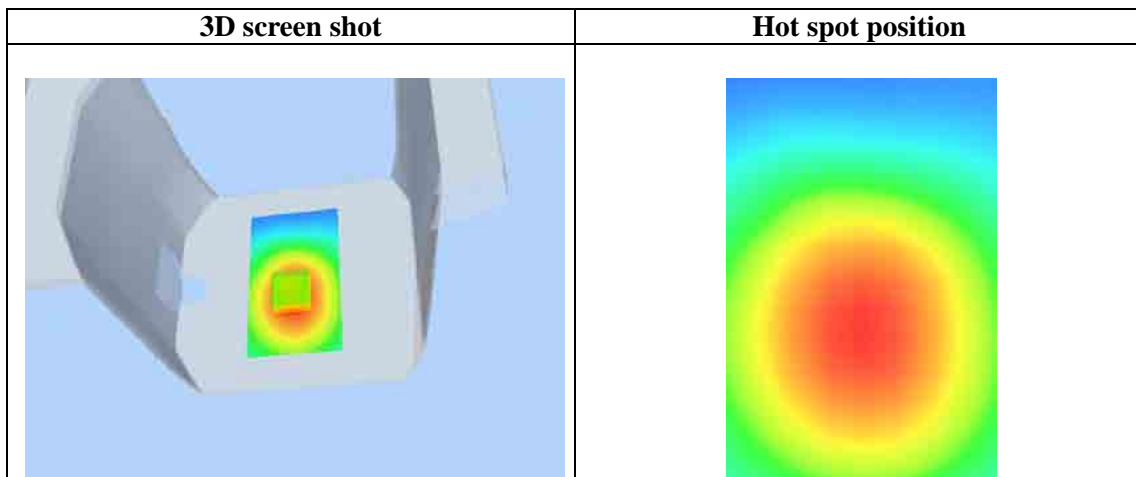
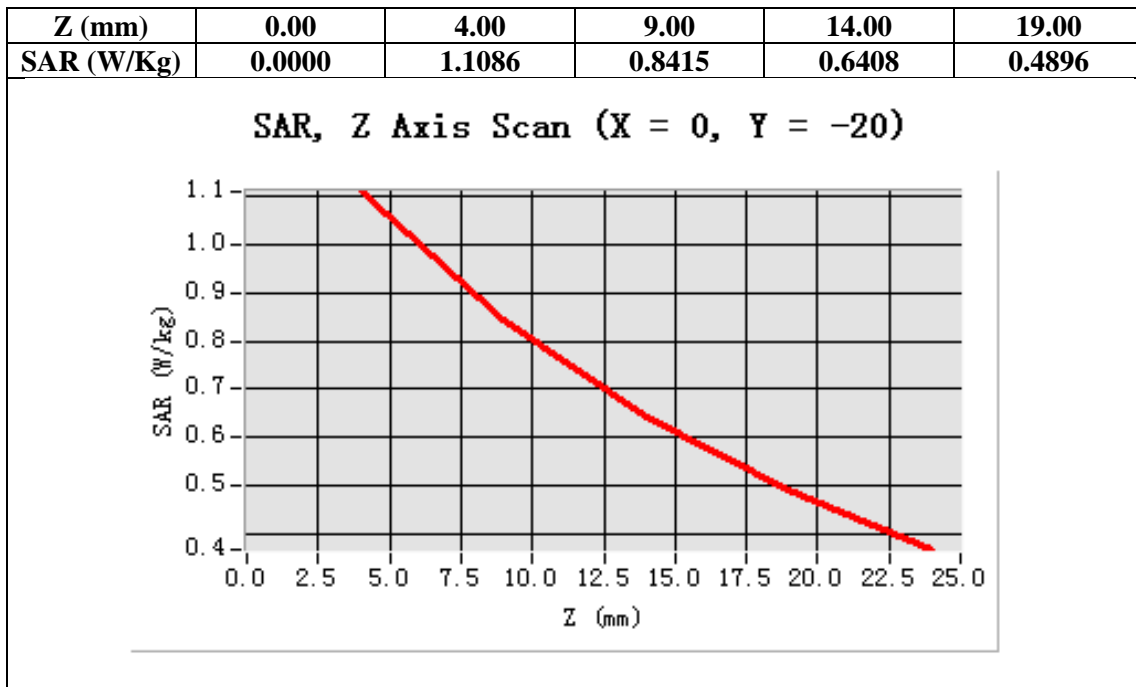

Test Laboratory: AGC Lab

Date: Jan.25,2014

WCDMA Band V High-Body-Towards Grounds (RMC)

DUT: Axe II 3G; Type: Z402

Communication System: UMTS; Communication System Band: BAND V UTRA/FDD; Duty Cycle:1: 1; Conv.F=5.46  
Frequency: 846.6 MHz; Medium parameters used:  $f = 835$  MHz;  $\sigma=0.95$  mho/m;  $\epsilon_r = 55.28$ ;  $\rho = 1000$  kg/m<sup>3</sup> ;  
Phantom section: Flat Section  
Ambient temperature (°C):21, Liquid temperature (°C):21

SATIMO Configuration:

- Probe: EP165; Calibrated: 01/31/2013
- Sensor-Surface: 4mm (Mechanical Surface Detection)
- Phantom: Flat Phantom; Type: Elliptical Phantom
- Measurement SW: OpenSAR V4\_02\_01

Configuration/ WCDMA Band V High-Body-Back/Area Scan (6x8x1): Measurement grid: dx=8mm, dy=8mm  
Configuration/ WCDMA Band V High-Body-Back/Zoom Scan (5x5x7)/Cube 0: Measurement grid:  
dx=8mm,dy=8mm, dz=5mm;

Area Scan	surf_sam_plan.txt
ZoomScan	5x5x7,dx=8mm dy=8mm dz=5mm,Very fast
Phantom	Validation plane
Device Position	Body Back
Band	WCDMA Band V
Channels	High
Signal	TDMA (Crest factor: 1.0)

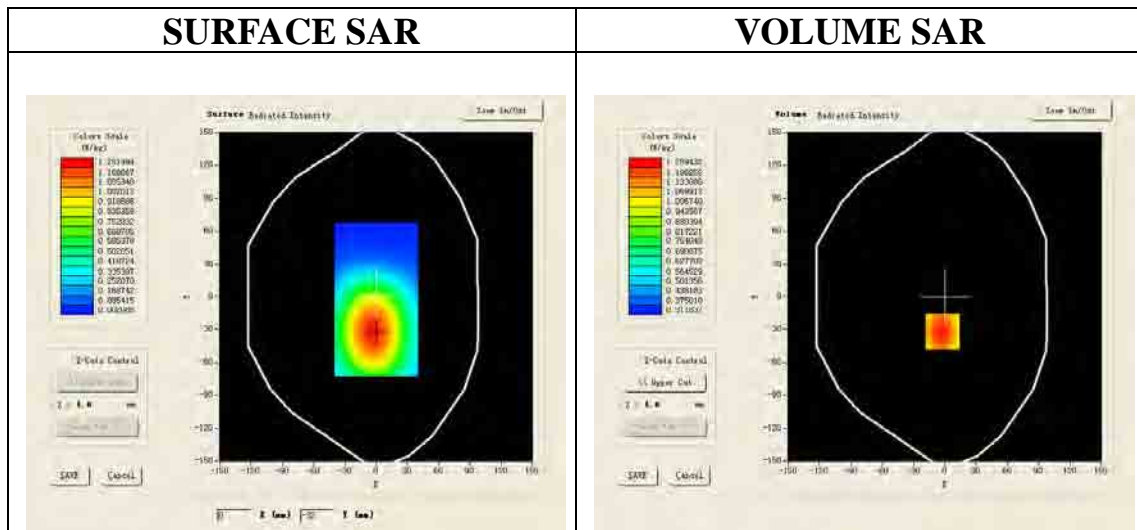

Maximum location: X=-2.00, Y=-32.00

SAR 10g (W/Kg)	0.882339
SAR 1g (W/Kg)	1.212801

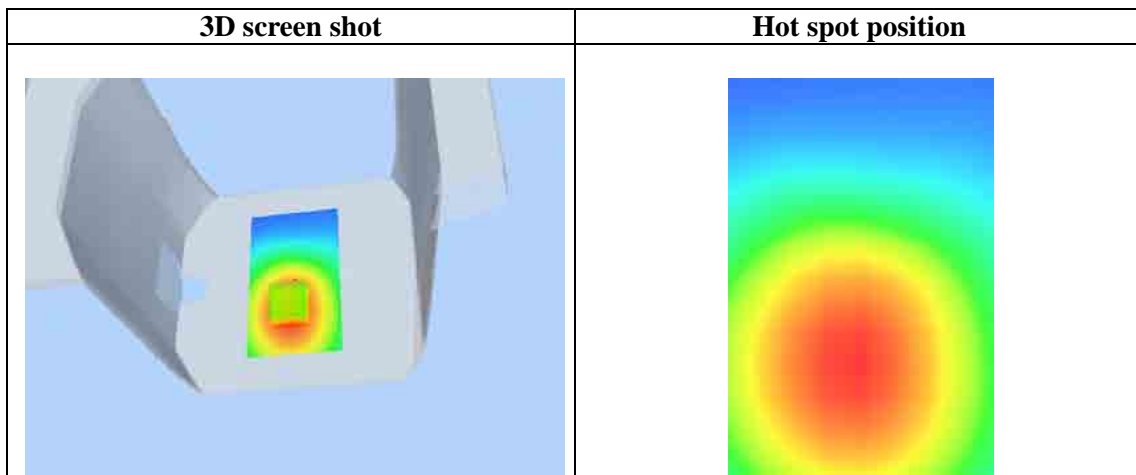
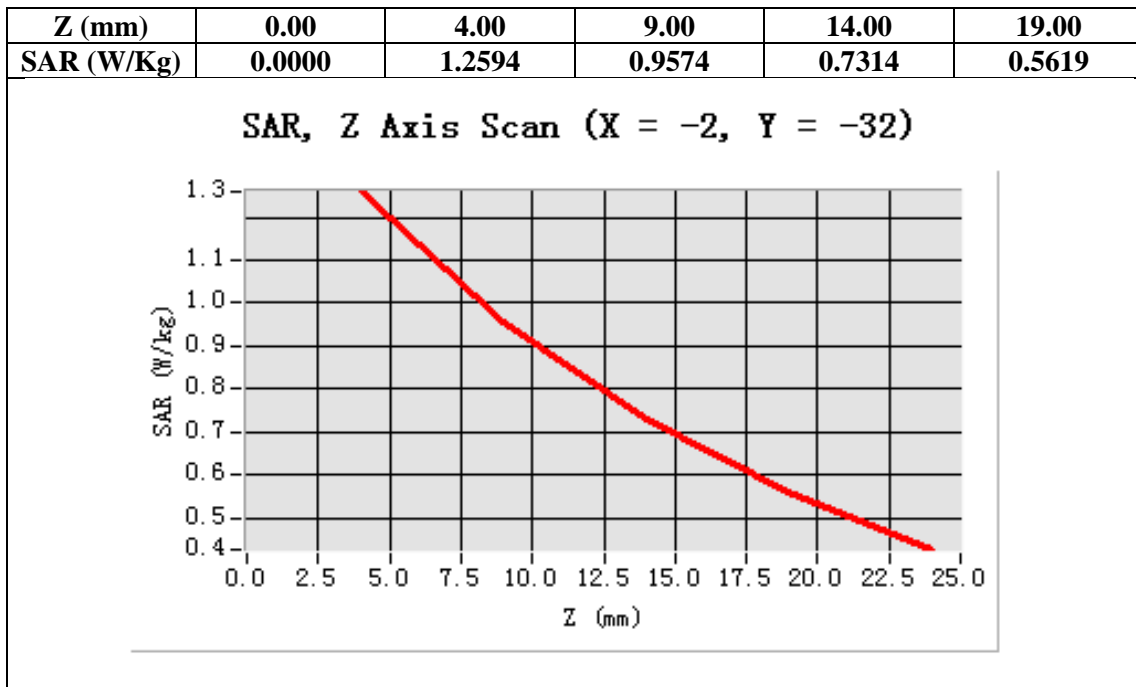

Test Laboratory: AGC Lab

Date: Jan.25,2014

WCDMA Band V Low- Body - Towards Phantom (RMC)

DUT: Axe II 3G; Type: Z402

Communication System: UMTS; Communication System Band: BAND V UTRA/FDD ; Duty Cycle:1: 1; Conv.F=5.46  
Frequency: 826.4 MHz; Medium parameters used:  $f = 835$  MHz; $\sigma=0.95$  mho/m;  $\epsilon_r = 54.88$ ;  $\rho = 1000$ kg/m<sup>3</sup> ;  
Phantom section: Flat Section  
Ambient temperature (°C):21, Liquid temperature (°C):21

SATIMO Configuration:

- Probe: EP165; Calibrated: 01/31/2013
- Sensor-Surface: 4mm (Mechanical Surface Detection)
- Phantom: Flat Phantom; Type: Elliptical Phantom
- Measurement SW: OpenSAR V4\_02\_01

Configuration/ WCDMA Band V Low-Body-Front/Area Scan (6x8x1): Measurement grid: dx=8mm, dy=8mm  
Configuration/ WCDMA Band V Low-Body-Front/Zoom Scan (5x5x7)/Cube 0: Measurement grid: dx=8mm, dy=8mm, dz=5mm;

Area Scan	surf_sam_plan.txt
ZoomScan	5x5x7,dx=8mm dy=8mm dz=5mm,Very fast
Phantom	Validation plane
Device Position	Body Front
Band	WCDMA Band V
Channels	Low
Signal	TDMA (Crest factor: 1.0)

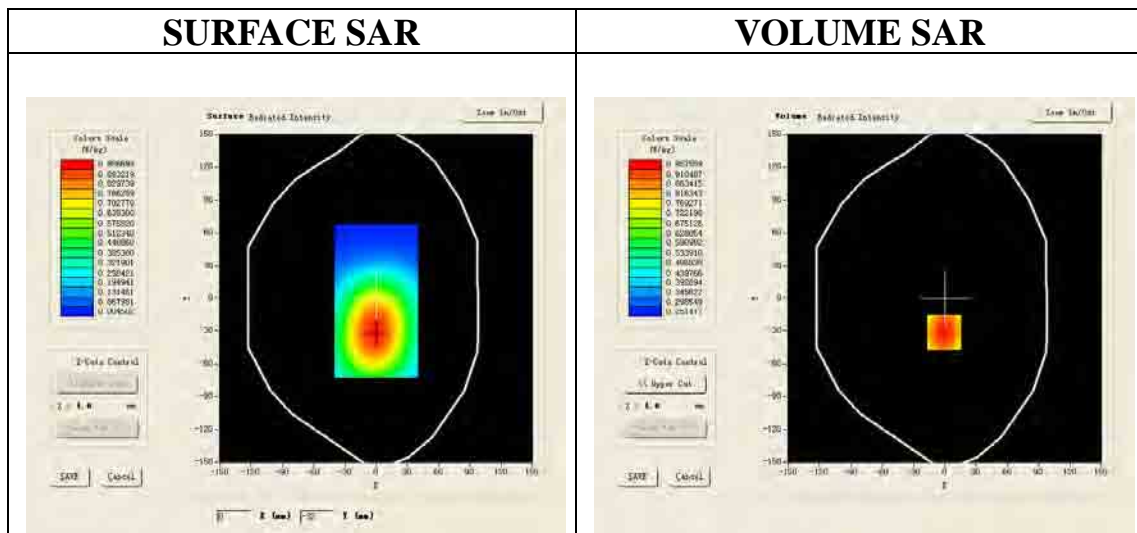

Maximum location: X=-1.00, Y=-31.00

SAR 10g (W/Kg)	0.678763
SAR 1g (W/Kg)	0.922782

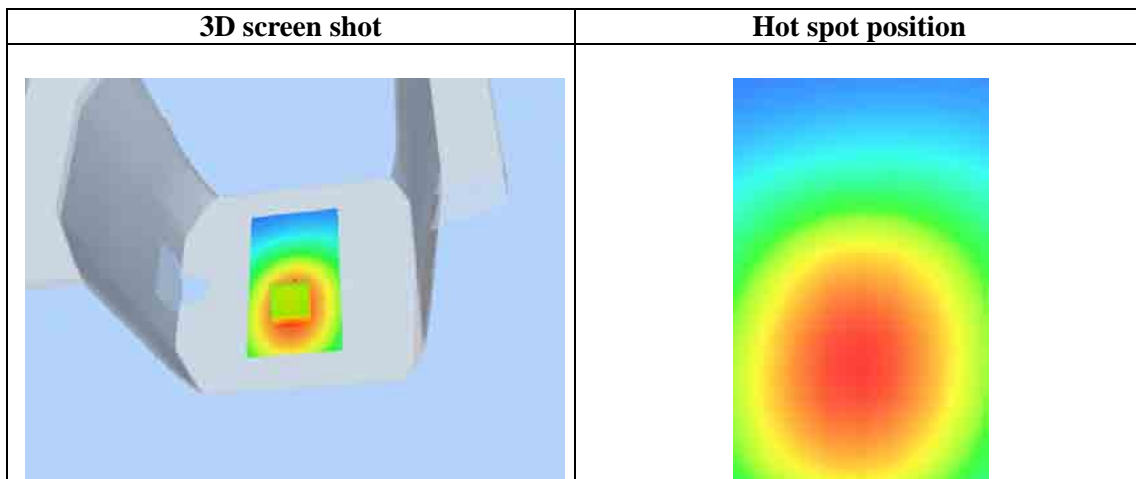
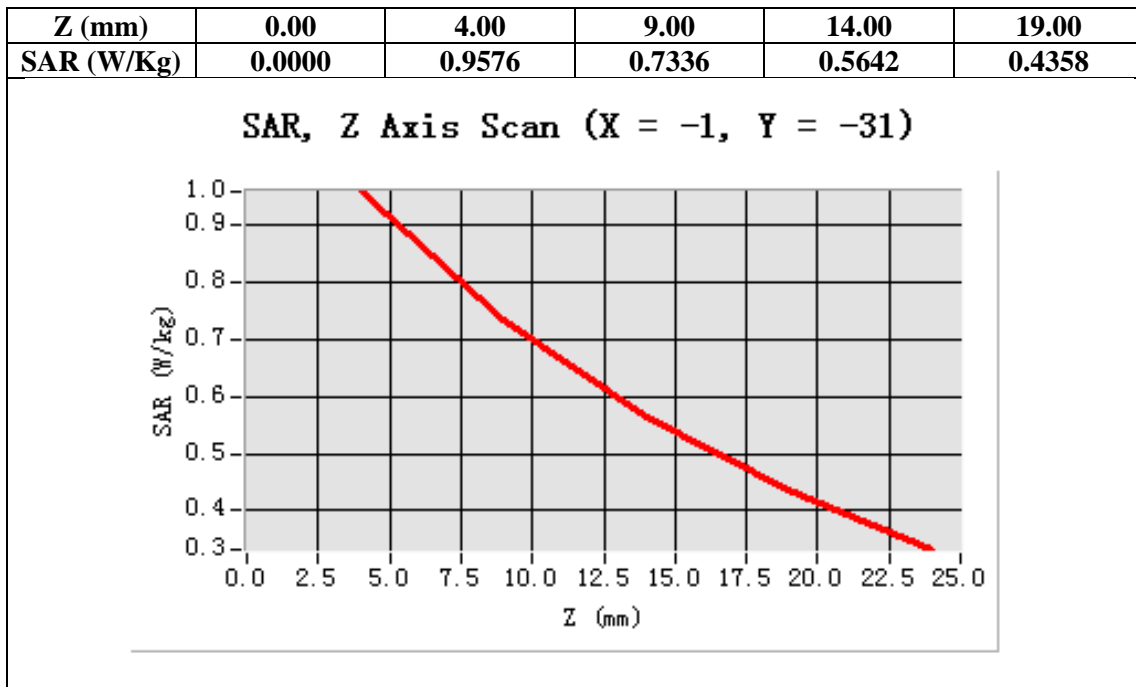



Test Laboratory: AGC Lab

Date: Jan.25,2014

WCDMA Band V Mid- Body - Towards Phantom (RMC)

DUT: Axe II 3G; Type: Z402

Communication System: UMTS; Communication System Band: BAND V UTRA/FDD ; Duty Cycle:1: 1; Conv.F=5.46  
Frequency: 835 MHz; Medium parameters used:  $f = 835$  MHz; $\sigma=0.96$  mho/m;  $\epsilon_r=55.02$ ;  $\rho= 1000$ kg/m<sup>3</sup> ;  
Phantom section: Flat Section  
Ambient temperature (°C):21, Liquid temperature (°C):21

SATIMO Configuration:

- Probe: EP165; Calibrated: 01/31/2013
- Sensor-Surface: 4mm (Mechanical Surface Detection)
- Phantom: Flat Phantom; Type: Elliptical Phantom
- Measurement SW: OpenSAR V4\_02\_01

Configuration/ WCDMA Band V Mid-Body-Front/Area Scan (6x8x1): Measurement grid: dx=8mm, dy=8mm  
Configuration/ WCDMA Band V Mid-Body-Front/Zoom Scan (5x5x7)/Cube 0: Measurement grid: dx=8mm, dy=8mm, dz=5mm;

Area Scan	surf_sam_plan.txt
ZoomScan	5x5x7,dx=8mm dy=8mm dz=5mm,Very fast
Phantom	Validation plane
Device Position	Body Front
Band	WCDMA Band V
Channels	Middle
Signal	TDMA (Crest factor: 1.0)

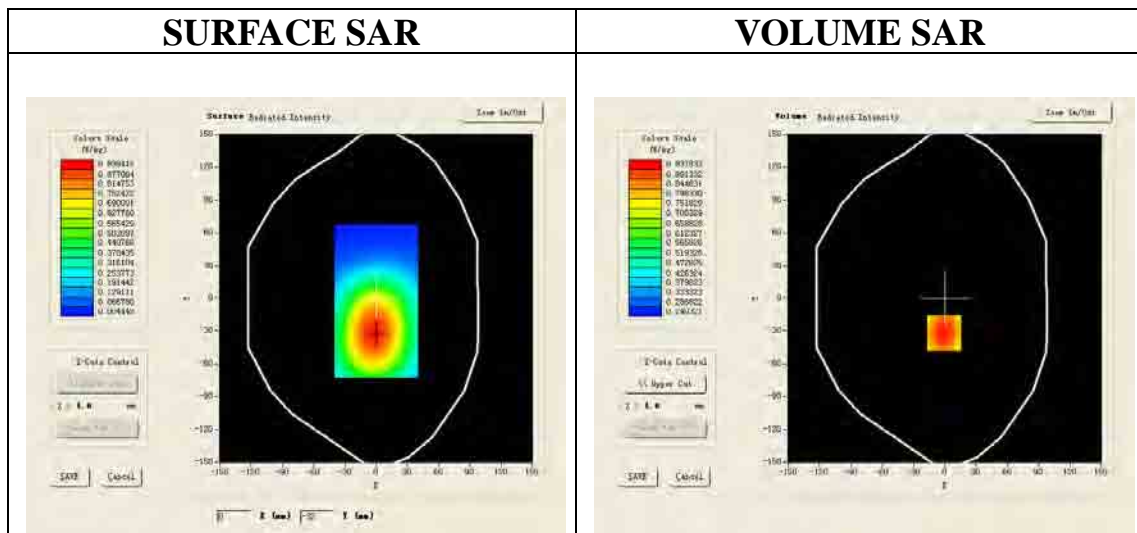

Maximum location: X=-1.00, Y=-32.00

SAR 10g (W/Kg)	0.662532
SAR 1g (W/Kg)	0.903426

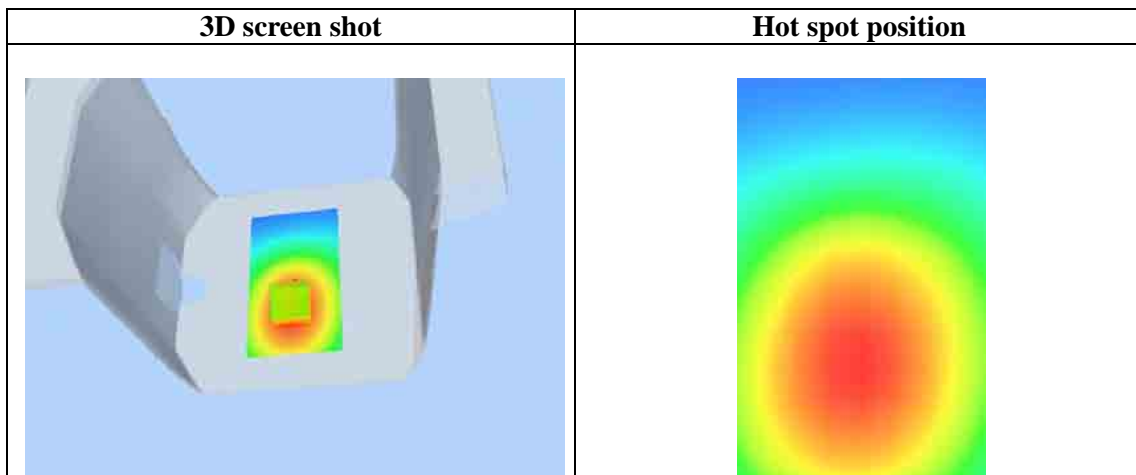
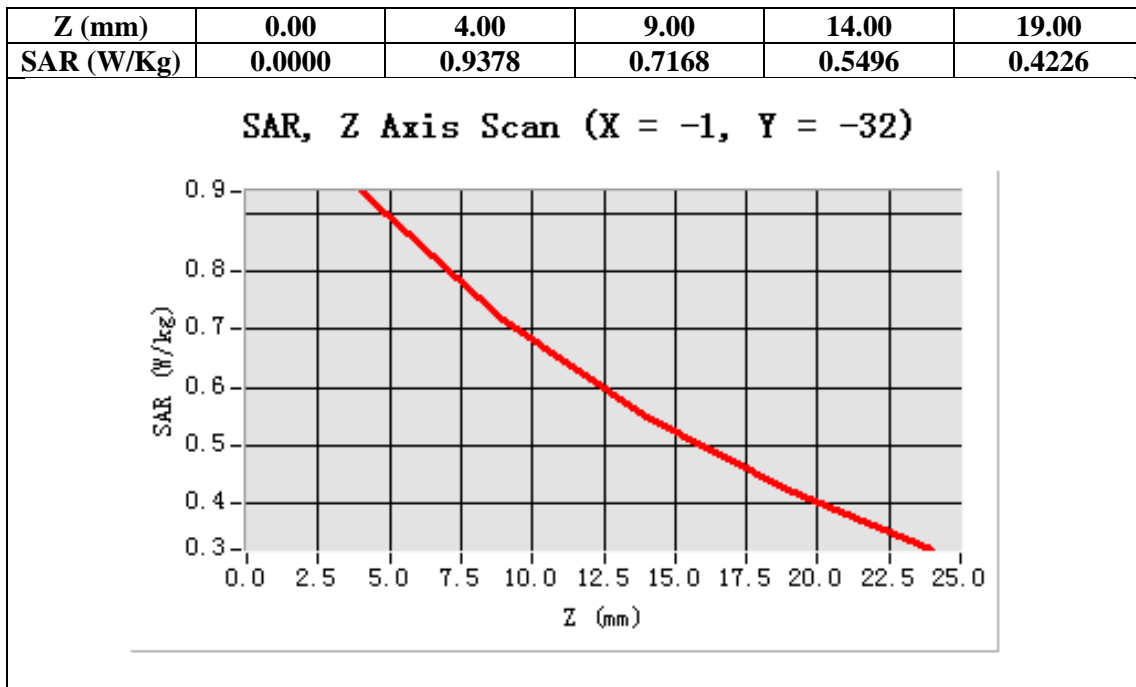

Test Laboratory: AGC Lab

Date: Jan.25,2014

WCDMA Band V High- Body - Towards Phantom (RMC)

DUT: Axe II 3G; Type: Z402

Communication System: UMTS; Communication System Band: BAND V UTRA/FDD ; Duty Cycle:1: 1; Conv.F=5.46  
Frequency: 846.6 MHz; Medium parameters used:  $f = 835$  MHz; $\sigma=0.95$  mho/m;  $\epsilon_r = 55.28$ ;  $\rho = 1000$ kg/m<sup>3</sup> ;  
Phantom section: Flat Section  
Ambient temperature (°C):21, Liquid temperature (°C):21

SATIMO Configuration:

- Probe: EP165; Calibrated: 01/31/2013
- Sensor-Surface: 4mm (Mechanical Surface Detection)
- Phantom: Flat Phantom; Type: Elliptical Phantom
- Measurement SW: OpenSAR V4\_02\_01

Configuration/ WCDMA Band V High-Body-Front/Area Scan (6x8x1): Measurement grid: dx=8mm, dy=8mm  
Configuration/ WCDMA Band V High-Body-Front/Zoom Scan (5x5x7)/Cube 0: Measurement grid: dx=8mm, dy=8mm, dz=5mm;

Area Scan	surf_sam_plan.txt
ZoomScan	5x5x7,dx=8mm dy=8mm dz=5mm,Very fast
Phantom	Validation plane
Device Position	Body Front
Band	WCDMA Band V
Channels	High
Signal	TDMA (Crest factor: 1.0)

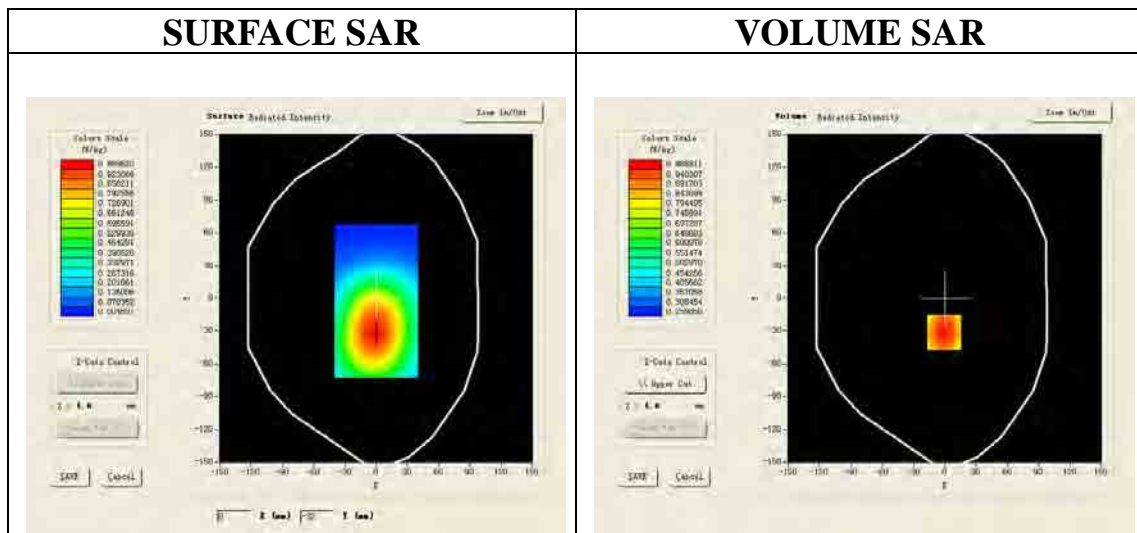

Maximum location: X=-1.00, Y=-31.00

SAR 10g (W/Kg)	0.700800
SAR 1g (W/Kg)	0.952914

Z (mm)	0.00	4.00	9.00	14.00	19.00
SAR (W/Kg)	0.0000	0.9889	0.7572	0.5824	0.4502

**SAR, Z Axis Scan (X = -1, Y = -31)**

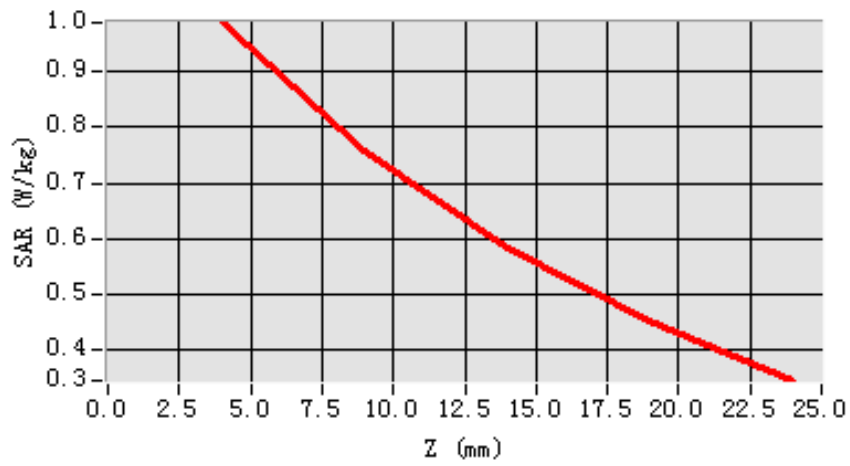

**3D screen shot**

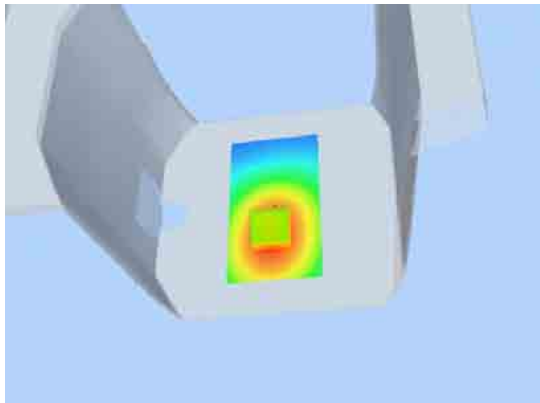

**Hot spot position**

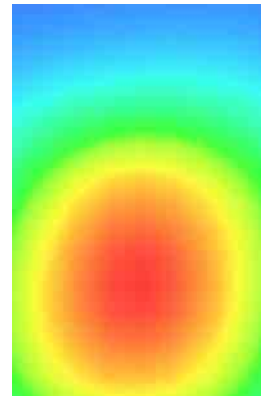

Test Laboratory: AGC Lab

Date: Jan.25,2014

WCDMA Band V Low- Body - Towards Grounds(HSPA) -with earphone

DUT: Axe II 3G; Type: Z402

Communication System: UMTS; Communication System Band: BAND V UTRA/FDD ; Duty Cycle:1: 1; Conv.F=5.46  
Frequency: 835 MHz; Medium parameters used:  $f = 835$  MHz; $\sigma=0.95$  mho/m;  $\epsilon_r = 54.88$ ;  $\rho = 1000$ kg/m<sup>3</sup> ;  
Phantom section: Flat Section  
Ambient temperature (°C):21, Liquid temperature (°C):21

SATIMO Configuration:

- Probe: EP165; Calibrated: 01/31/2013
- Sensor-Surface: 4mm (Mechanical Surface Detection)
- Phantom: Flat Phantom; Type: Elliptical Phantom
- Measurement SW: OpenSAR V4\_02\_01

Configuration/ WCDMA Band V Low-Body- Back /Area Scan (6x8x1): Measurement grid: dx=8mm, dy=8mm  
Configuration/ WCDMA Band V Low-Body- Back /Zoom Scan (5x5x7)/Cube 0: Measurement grid: dx=8mm, dy=8mm, dz=5mm;

Area Scan	surf_sam_plan.txt
ZoomScan	5x5x7,dx=8mm dy=8mm dz=5mm,Very fast
Phantom	Validation plane
Device Position	Body Back
Band	WCDMA Band V
Channels	Low
Signal	TDMA (Crest factor: 1.0)

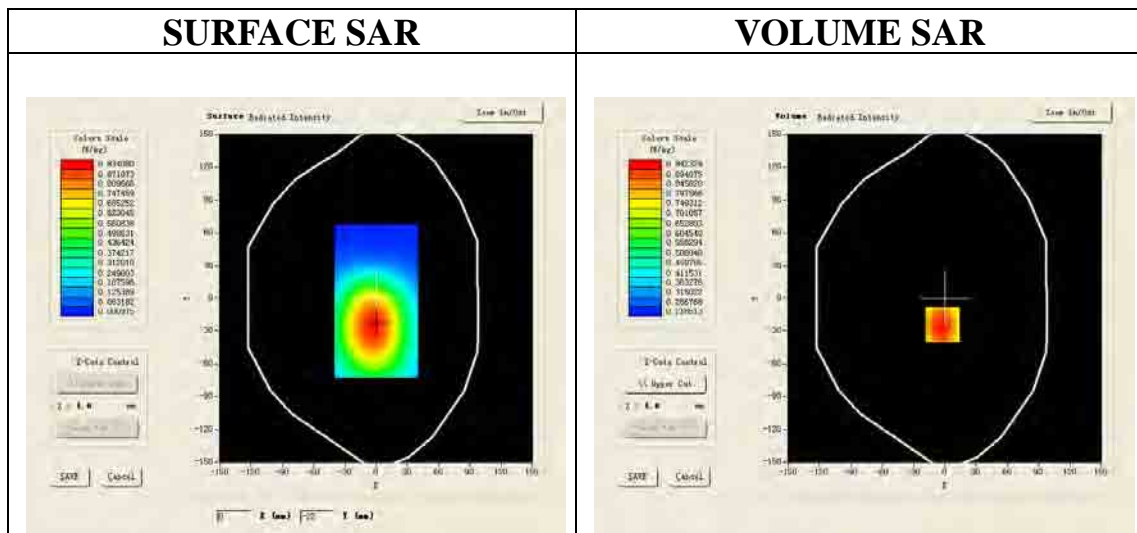

Maximum location: X=-2.00, Y=-24.00

SAR 10g (W/Kg)	0.656653
SAR 1g (W/Kg)	0.907910

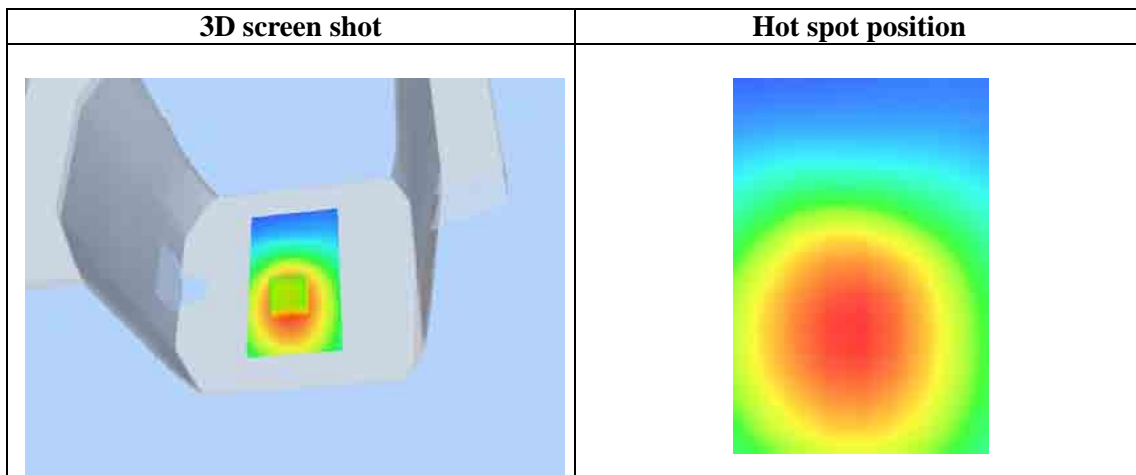
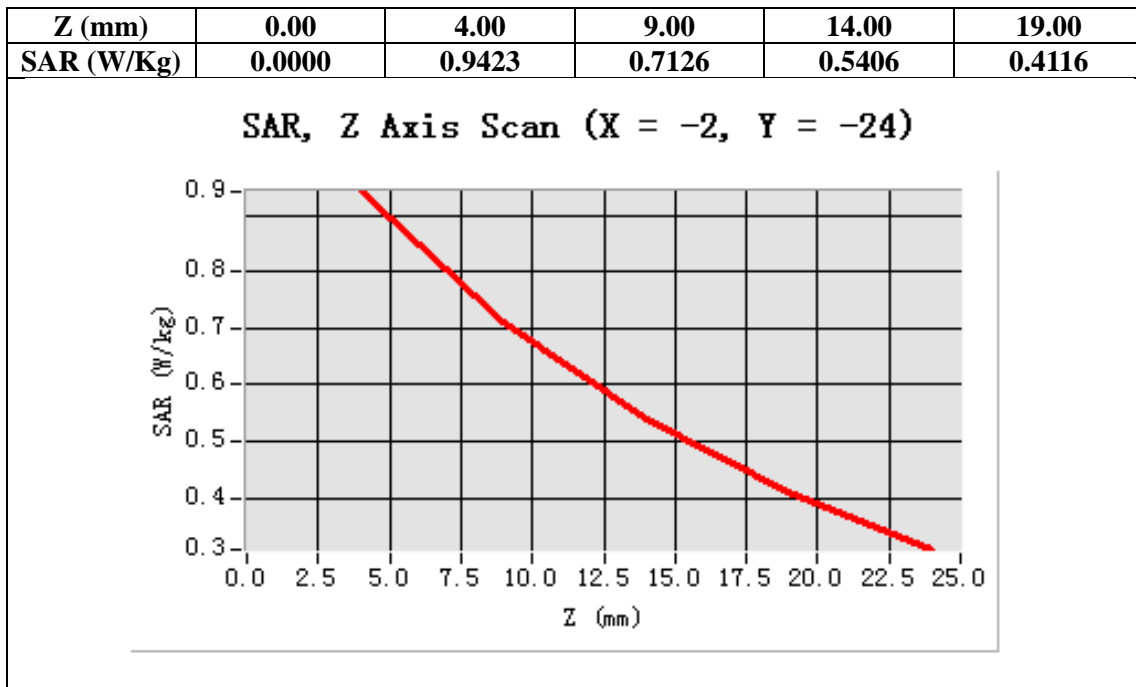

Test Laboratory: AGC Lab

Date: Jan.25,2014

WCDMA Band V Mid- Body - Towards Grounds(HSPA) -with earphone

DUT: Axe II 3G; Type: Z402

Communication System: UMTS; Communication System Band: BAND V UTRA/FDD ; Duty Cycle:1: 1; Conv.F=5.46  
Frequency: 835 MHz; Medium parameters used:  $f = 835$  MHz; $\sigma=0.96$  mho/m;  $\epsilon_r=55.02$ ;  $\rho= 1000$ kg/m<sup>3</sup> ;  
Phantom section: Flat Section  
Ambient temperature (°C):21, Liquid temperature (°C):21

SATIMO Configuration:

- Probe: EP165; Calibrated: 01/31/2013
- Sensor-Surface: 4mm (Mechanical Surface Detection)
- Phantom: Flat Phantom; Type: Elliptical Phantom
- Measurement SW: OpenSAR V4\_02\_01

Configuration/ WCDMA Band V Mid-Body- Back /Area Scan (6x8x1): Measurement grid: dx=8mm, dy=8mm  
Configuration/ WCDMA Band V Mid-Body- Back /Zoom Scan (5x5x7)/Cube 0: Measurement grid: dx=8mm, dy=8mm, dz=5mm;

Area Scan	surf_sam_plan.txt
ZoomScan	5x5x7,dx=8mm dy=8mm dz=5mm,Very fast
Phantom	Validation plane
Device Position	Body Back
Band	WCDMA Band V
Channels	Middle
Signal	TDMA (Crest factor: 1.0)

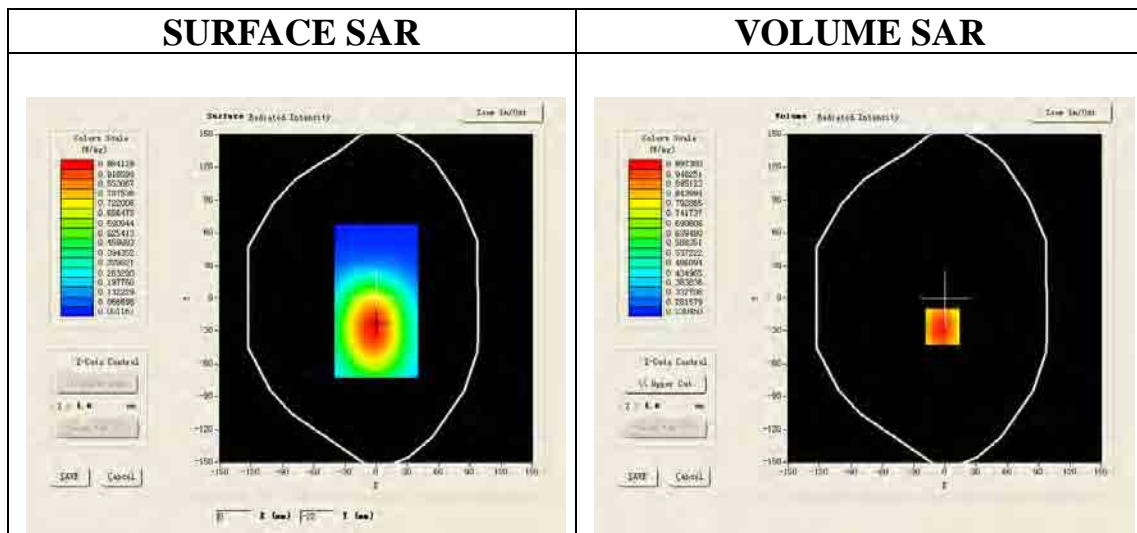

Maximum location: X=-2.00, Y=-26.00

SAR 10g (W/Kg)	0.693200
SAR 1g (W/Kg)	0.960624

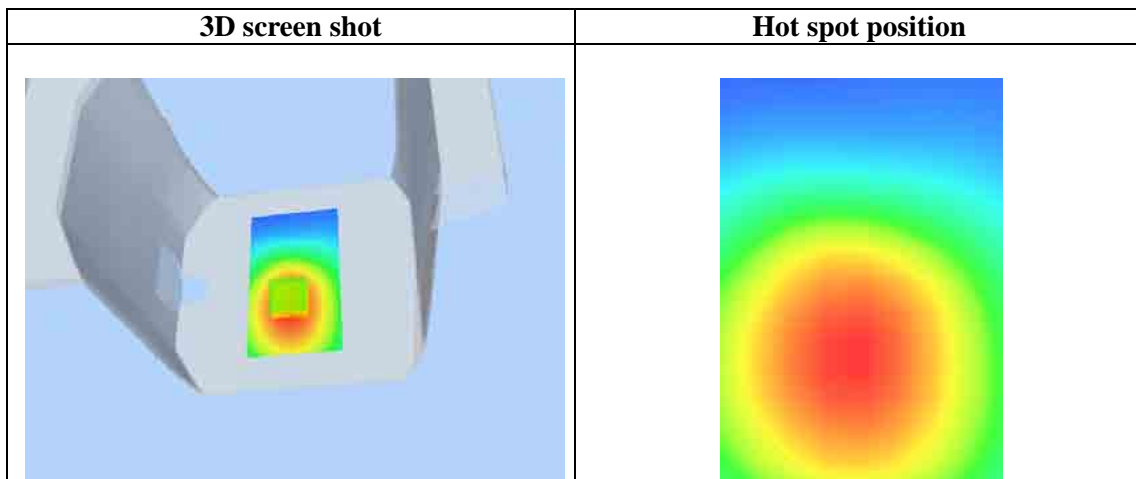
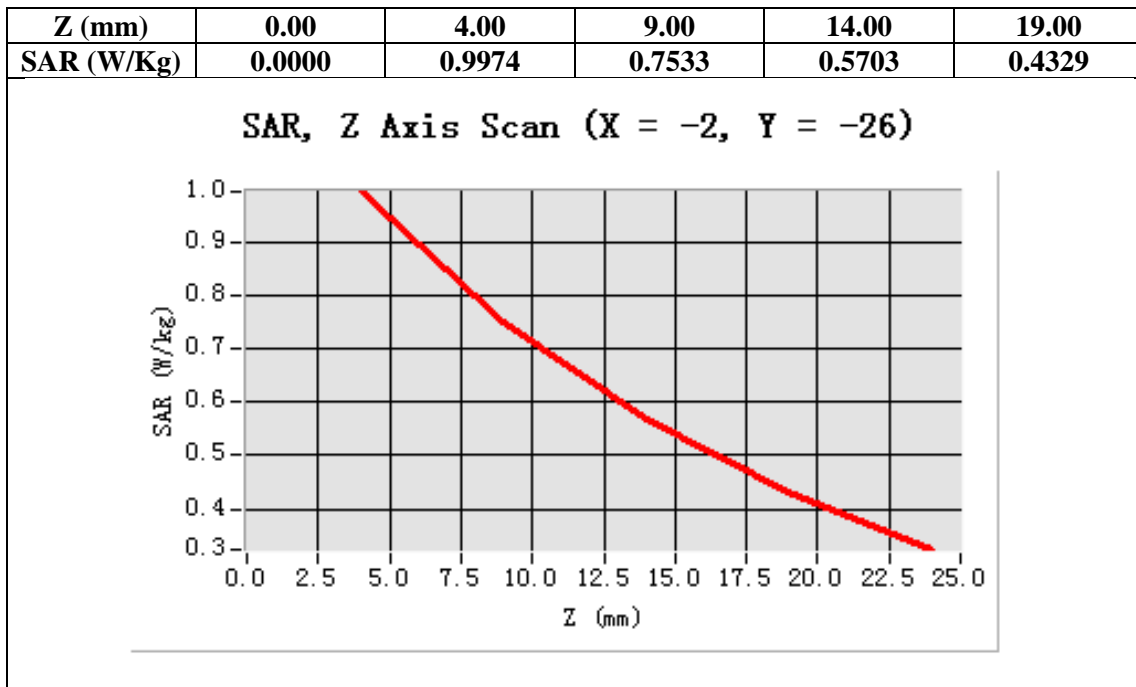



Test Laboratory: AGC Lab

Date: Jan.25,2014

WCDMA Band V High- Body - Towards Grounds(HSPA) -with earphone

DUT: Axe II 3G; Type: Z402

Communication System: UMTS; Communication System Band: BAND V UTRA/FDD ; Duty Cycle:1: 1; Conv.F=5.46  
Frequency: 846.6 MHz; Medium parameters used:  $f = 835$  MHz; $\sigma=0.95$  mho/m;  $\epsilon_r =55.28$ ;  $\rho = 1000$ kg/m<sup>3</sup> ;  
Phantom section: Flat Section  
Ambient temperature (°C):21, Liquid temperature (°C):21

SATIMO Configuration:

- Probe: EP165; Calibrated: 01/31/2013
- Sensor-Surface: 4mm (Mechanical Surface Detection)
- Phantom: Flat Phantom; Type: Elliptical Phantom
- Measurement SW: OpenSAR V4\_02\_01

Configuration/ WCDMA Band V High-Body- Back /Area Scan (6x8x1): Measurement grid: dx=8mm, dy=8mm  
Configuration/ WCDMA Band V High-Body- Back /Zoom Scan (5x5x7)/Cube 0: Measurement grid: dx=8mm, dy=8mm, dz=5mm;

Area Scan	surf_sam_plan.txt
ZoomScan	5x5x7,dx=8mm dy=8mm dz=5mm,Very fast
Phantom	Validation plane
Device Position	Body Back
Band	WCDMA Band V
Channels	High
Signal	TDMA (Crest factor: 1.0)

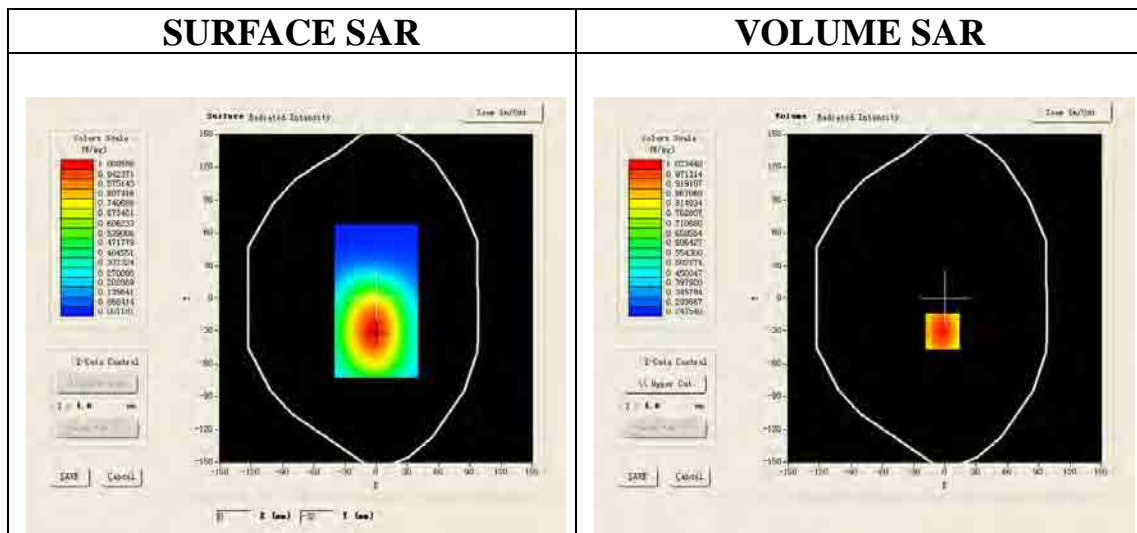

Maximum location: X=-2.00, Y=-30.00

SAR 10g (W/Kg)	0.710019
SAR 1g (W/Kg)	0.984400

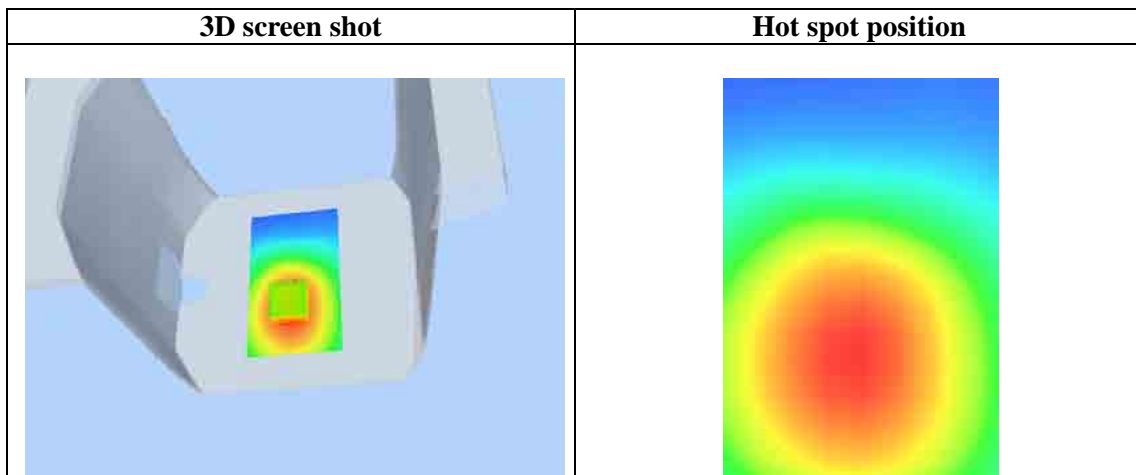
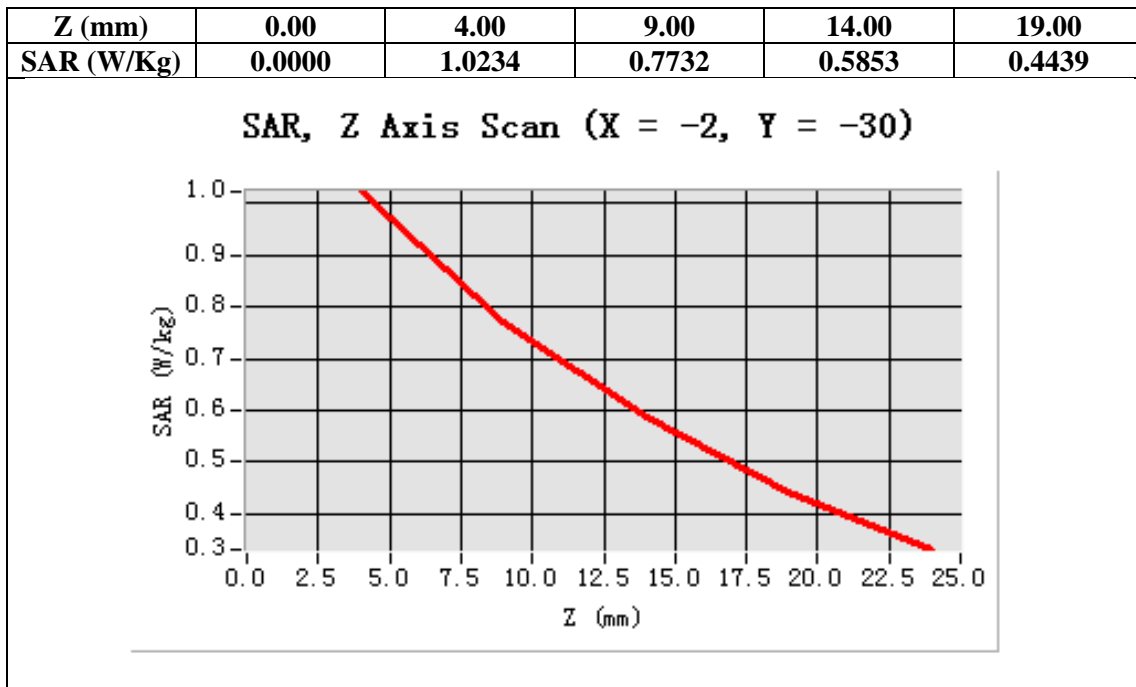

**Repeated SAR**

Test Laboratory: AGC Lab  
WCDMA Band II Mid-Touch-Right (RMC)  
DUT: Axe II 3G; Type: Z402

Date: Jan.25,2014

Communication System: UMTS; Communication System Band: Band II UTRA/FDD ;Duty Cycle:1:1; Conv.F=4.72  
Frequency: 1880 MHz; Medium parameters used: f = 1900 MHz;  $\sigma = 1.4$  mho/m;  $\epsilon_r = 39.28$ ;  $\rho = 1000$  kg/m<sup>3</sup> ;  
Phantom section: Right Section  
Ambient temperature (°C):21, Liquid temperature (°C):21

SATIMO Configuration:

- Probe: EP165; Calibrated: 01/31/2013
- Sensor-Surface: 4mm (Mechanical Surface Detection)
- Phantom: Flat Phantom; Type: Elliptical Phantom
- Measurement SW: OpenSAR V4\_02\_01

Configuration/ WCDMA band II Mid-Touch-Right/Area Scan: Measurement grid: dx=8mm, dy=8mm  
Configuration/ WCDMA band II Mid-Touch-Right/Zoom Scan: Measurement grid: dx=8mm, dy=8mm, dz=5mm;

<b>Area Scan</b>	sam_direct_droit2_surf8mm.txt
<b>ZoomScan</b>	5x5x7,dx=8mm dy=8mm dz=5mm,Very fast
<b>Phantom</b>	Right head
<b>Device Position</b>	Cheek
<b>Band</b>	WCDMA band II
<b>Channels</b>	Middle
<b>Signal</b>	TDMA (Crest factor: 1.0)

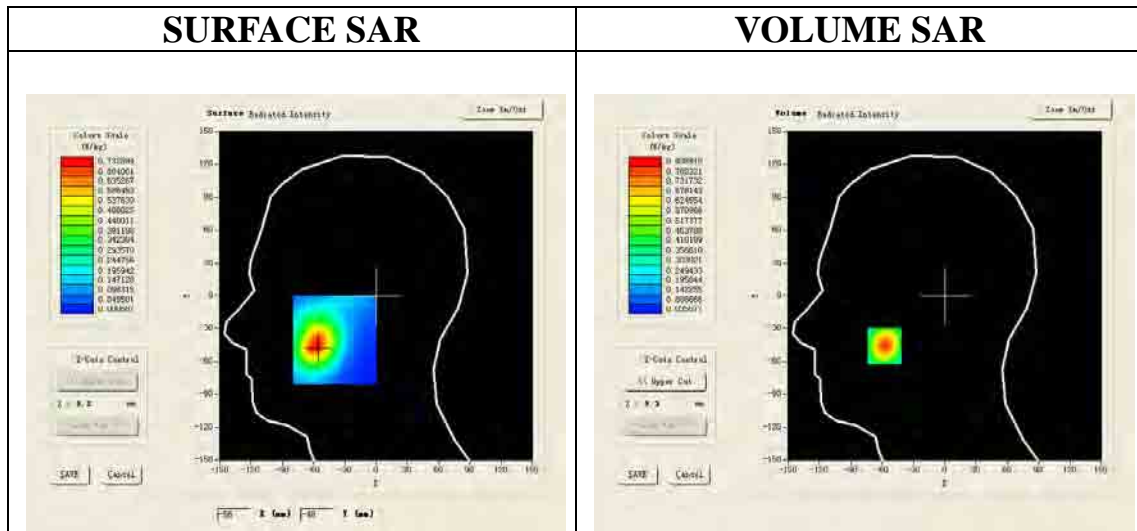

**Maximum location: X=-58.00, Y=-46.00**

<b>SAR 10g (W/Kg)</b>	0.426046
<b>SAR 1g (W/Kg)</b>	0.805274

Z (mm)	0.00	4.00	9.00	14.00	19.00
SAR (W/Kg)	0.0000	0.8416	0.4743	0.2813	0.1827

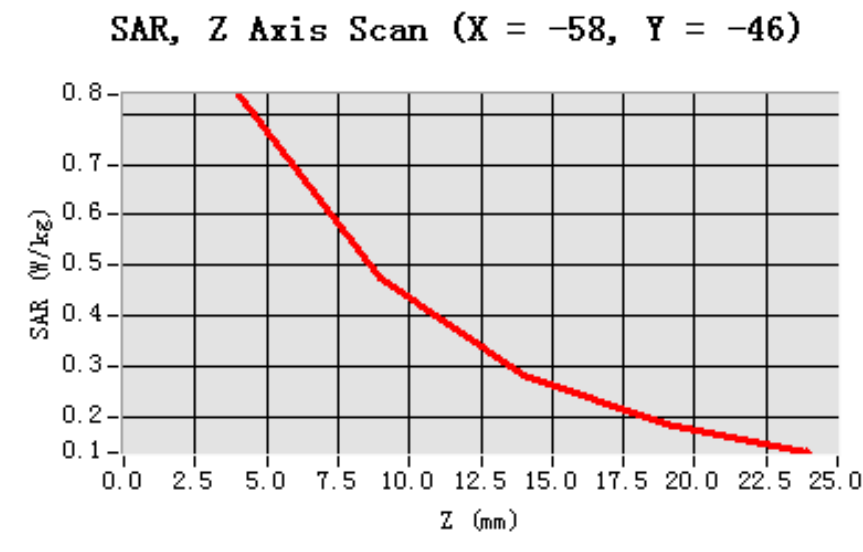

**3D screen shot**

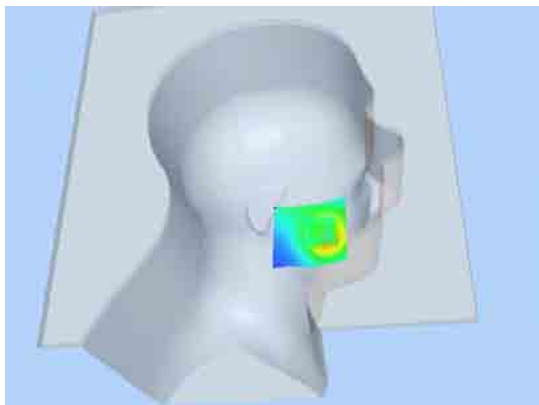

**Hot spot position**

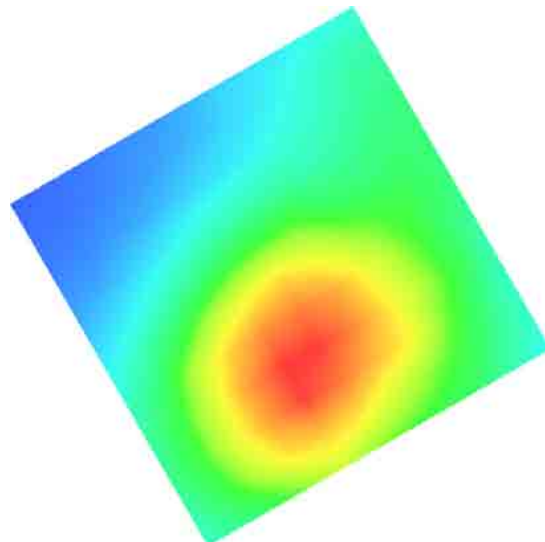

Test Laboratory: AGC Lab  
WCDMA Band II Low-Body-Towards Grounds (RMC)  
DUT: Axe II 3G; Type: Z402

Date: Jan.25,2014

Communication System: UMTS; Communication System Band: Band II UTRA/FDD ;Duty Cycle:1:1; ConvF=4.84  
Frequency: 1852.4 MHz; Medium parameters used:  $f = 1900$  MHz;  $\sigma=1.50$  mho/m;  $\epsilon_r =54.01$ ;  $\rho= 1000$  kg/m<sup>3</sup> ;  
Phantom section: Flat Section  
Ambient temperature (°C):21, Liquid temperature (°C):21

SATIMO Configuration:

- Probe: EP165; Calibrated: 01/31/2013
- Sensor-Surface: 4mm (Mechanical Surface Detection)
- Phantom: Flat Phantom; Type: Elliptical Phantom
- Measurement SW: OpenSAR V4\_02\_01

Configuration/ WCDMA band II Low-Body-back/Area Scan: Measurement grid: dx=8mm, dy=8mm  
Configuration/ WCDMA band II Low-Body-back/Zoom Scan: Measurement grid: dx=8mm, dy=8mm, dz=5mm;

Area Scan	surf_sam_plan.txt
ZoomScan	5x5x7,dx=8mm dy=8mm dz=5mm,Very fast
Phantom	Validation plane
Device Position	Body Back
Band	WCDMA band II
Channels	Low
Signal	TDMA (Crest factor: 1.0)

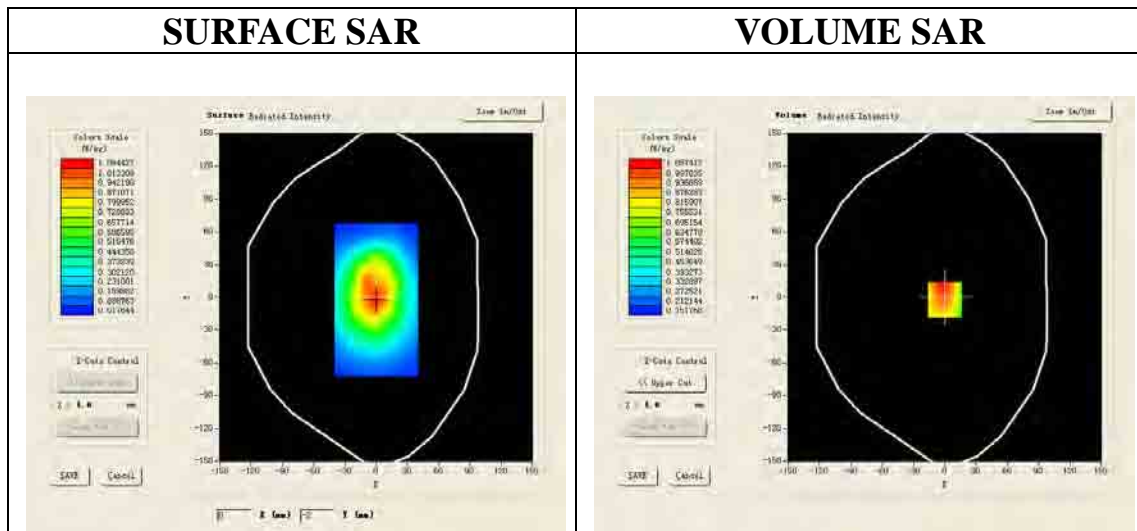

Maximum location: X=0.00, Y=-2.00

SAR 10g (W/Kg)	0.725551
SAR 1g (W/Kg)	0.869457

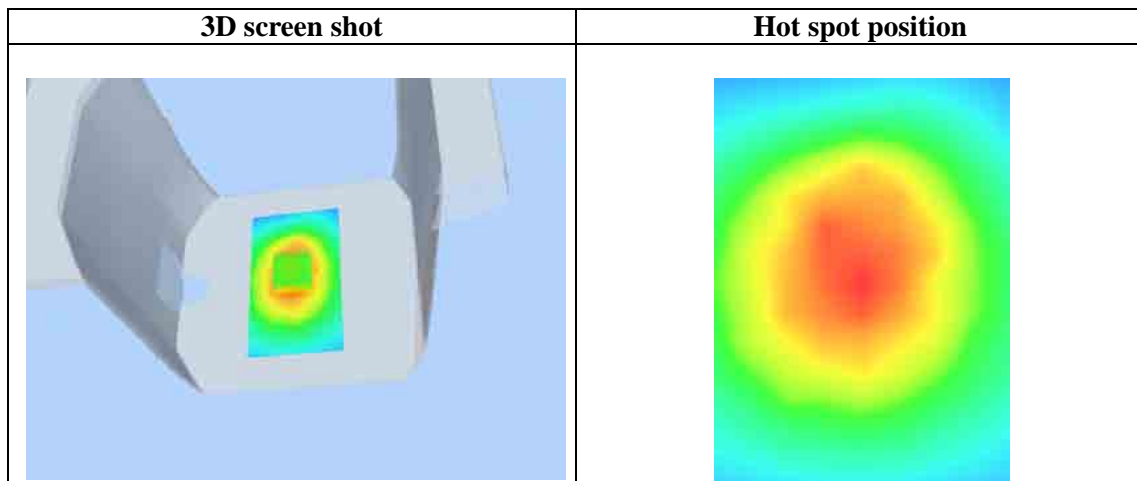
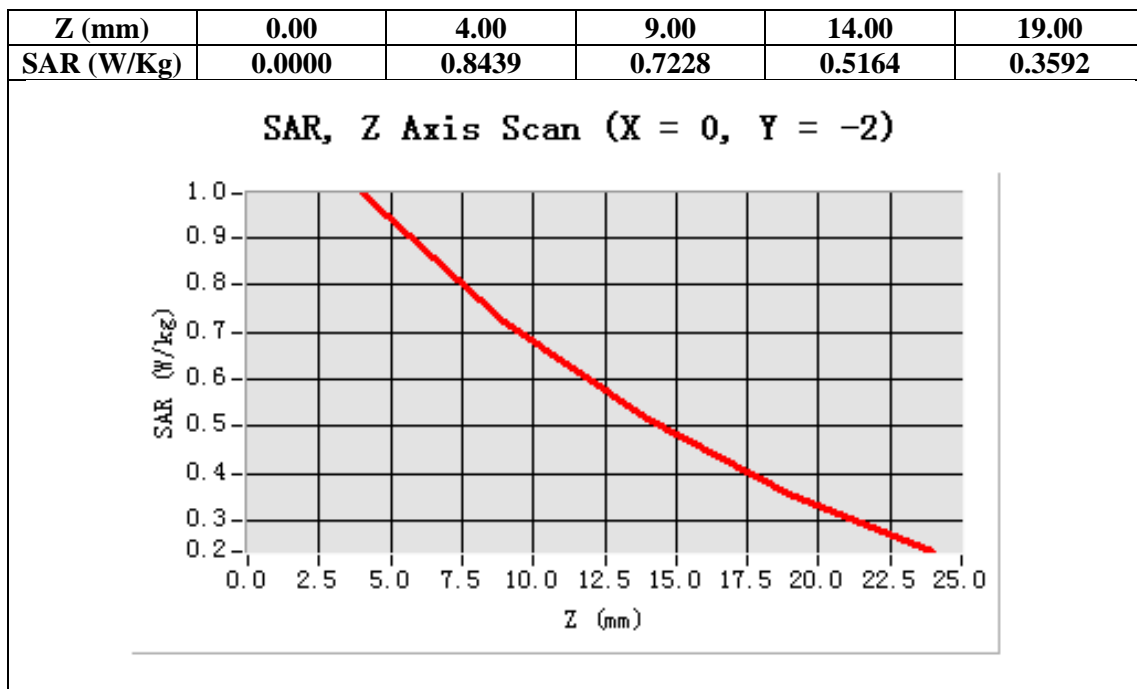

Test Laboratory: AGC Lab

Date: Jan.25,2014

WCDMA Band V High-Touch-Right (RMC)

DUT: Axe II 3G; Type: Z402

Communication System: UMTS; Communication System Band: BAND V UTRA/FDD ; Duty Cycle:1: 1; Conv.F=5.30  
Frequency: 846.6 MHz; Medium parameters used:  $f = 835$  MHz;  $\sigma=0.88$  mho/m;  $\epsilon_r = 40.87$ ;  $\rho = 1000$  kg/m<sup>3</sup> ;  
Phantom section: Right Section  
Ambient temperature (°C): 21, Liquid temperature (°C): 21

SATIMO Configuration:

- Probe: EP165; Calibrated: 01/31/2013
- Sensor-Surface: 4mm (Mechanical Surface Detection)
- Phantom: Flat Phantom; Type: Elliptical Phantom
- Measurement SW: OpenSAR V4\_02\_01

Configuration/ WCDMA Band V High-Touch-Right/Area Scan: Measurement grid: dx=8mm, dy=8mm  
Configuration/ WCDMA Band V High-Touch-Right/Zoom Scan: Measurement grid: dx=8mm, dy=8mm, dz=5mm;

<b>Area Scan</b>	sam_direct_droit2_surf8mm.txt
<b>ZoomScan</b>	5x5x7,dx=8mm dy=8mm dz=5mm,Very fast
<b>Phantom</b>	Right head
<b>Device Position</b>	Cheek
<b>Band</b>	WCDMA Band V
<b>Channels</b>	High
<b>Signal</b>	TDMA (Crest factor: 1.0)

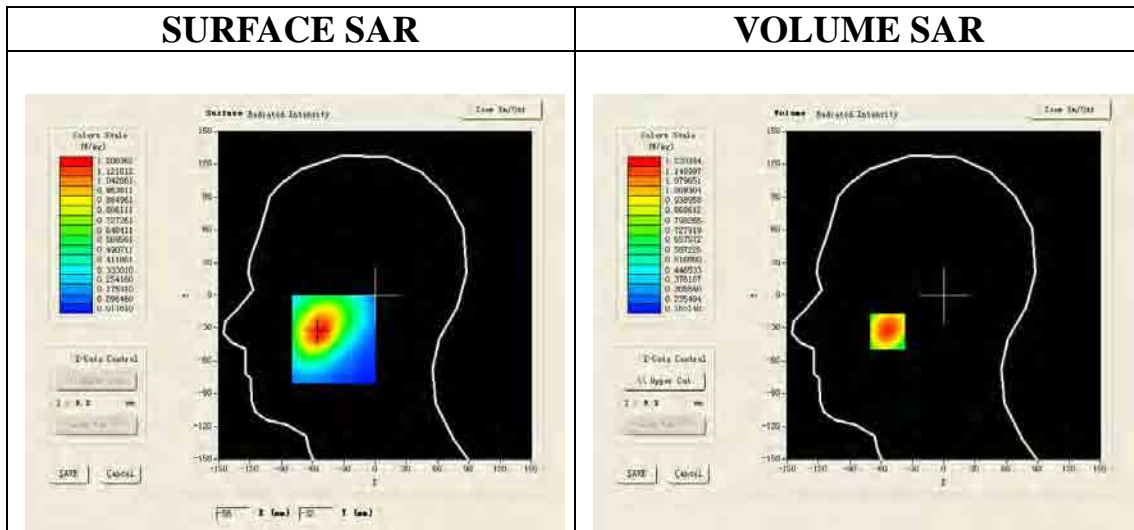

**Maximum location: X=-54.00, Y=-33.00**

<b>SAR 10g (W/Kg)</b>	0.828472
<b>SAR 1g (W/Kg)</b>	1.165745

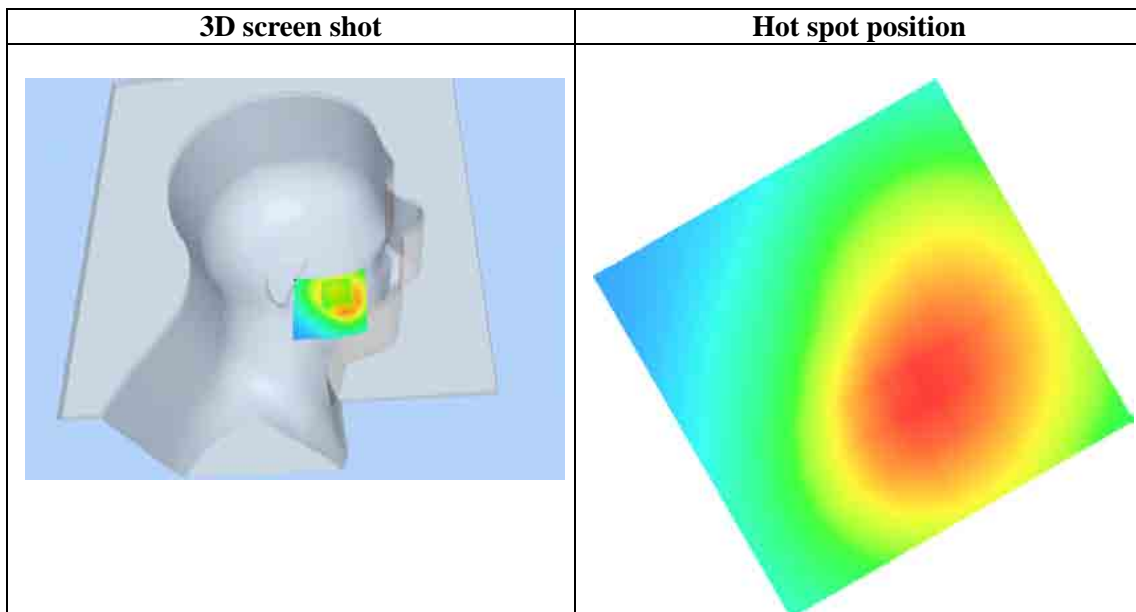
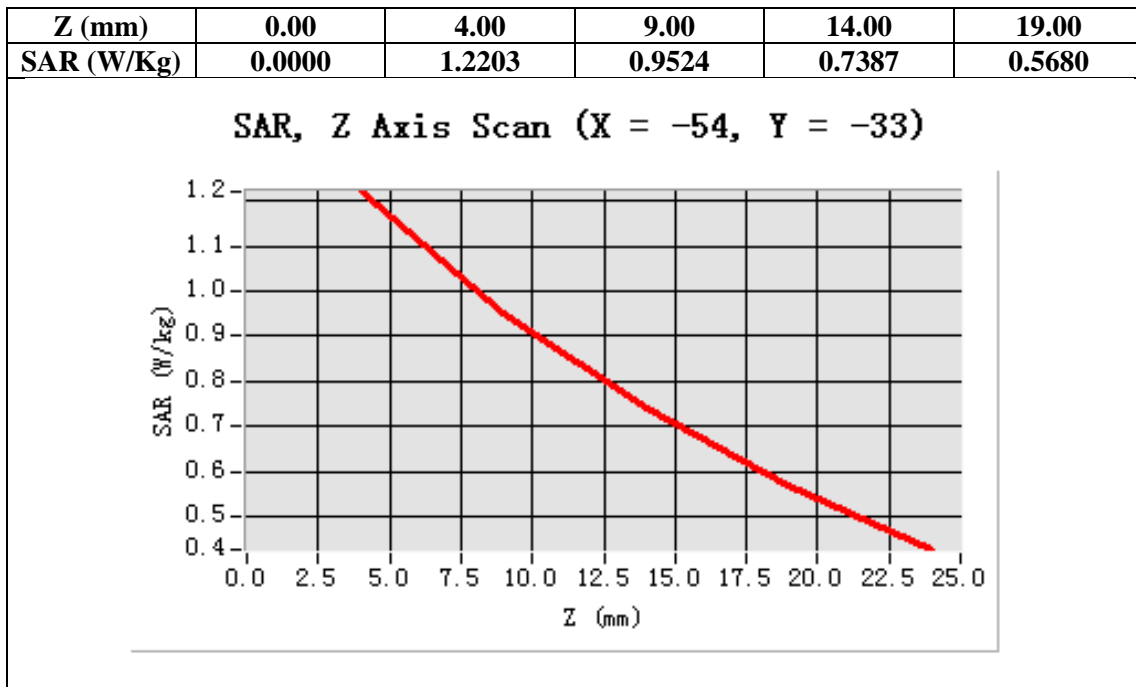



Test Laboratory: AGC Lab

Date: Jan.25,2014

WCDMA Band V High-Touch-Right (RMC)

DUT: Axe II 3G; Type: Z402

Communication System: UMTS; Communication System Band: BAND V UTRA/FDD ; Duty Cycle:1: 1; Conv.F=5.30  
Frequency: 846.6 MHz; Medium parameters used:  $f = 835$  MHz;  $\sigma=0.88$  mho/m;  $\epsilon_r = 40.87$ ;  $\rho = 1000$  kg/m<sup>3</sup> ;  
Phantom section: Right Section  
Ambient temperature (°C): 21, Liquid temperature (°C): 21

SATIMO Configuration:

- Probe: EP165; Calibrated: 01/31/2013
- Sensor-Surface: 4mm (Mechanical Surface Detection)
- Phantom: Flat Phantom; Type: Elliptical Phantom
- Measurement SW: OpenSAR V4\_02\_01

Configuration/ WCDMA Band V High-Touch-Right/Area Scan: Measurement grid: dx=8mm, dy=8mm  
Configuration/ WCDMA Band V High-Touch-Right/Zoom Scan: Measurement grid: dx=8mm, dy=8mm, dz=5mm;

Area Scan	sam_direct_droit2_surf8mm.txt
ZoomScan	5x5x7,dx=8mm dy=8mm dz=5mm,Very fast
Phantom	Right head
Device Position	Cheek
Band	WCDMA Band V
Channels	High
Signal	TDMA (Crest factor: 1.0)

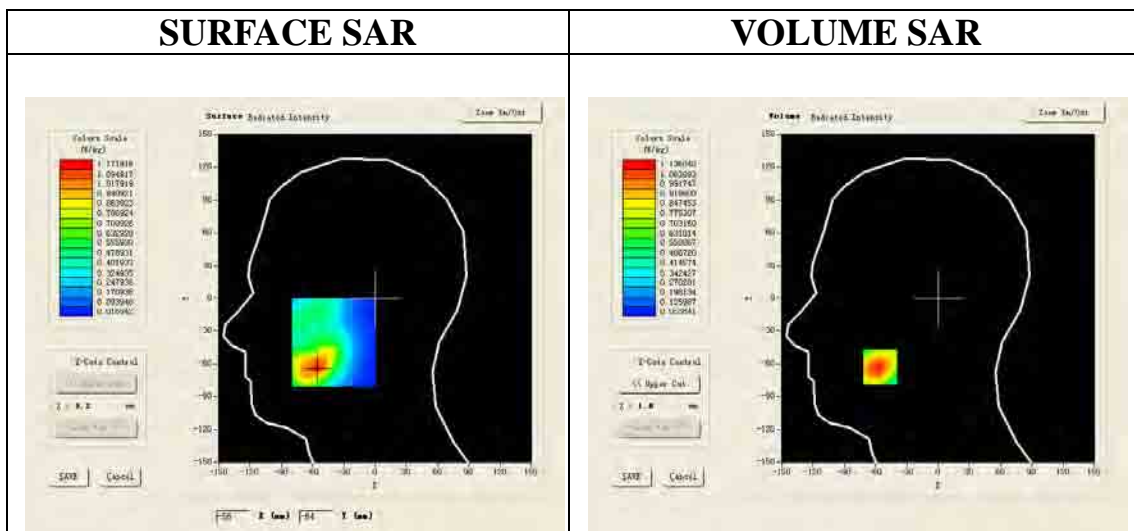

Maximum location: X=-56.00, Y=-63.00

SAR 10g (W/Kg)	0.631960
SAR 1g (W/Kg)	1.050397

Z (mm)	0.00	4.00	9.00	14.00	19.00
SAR (W/Kg)	0.0000	1.1360	0.6575	0.4005	0.2714

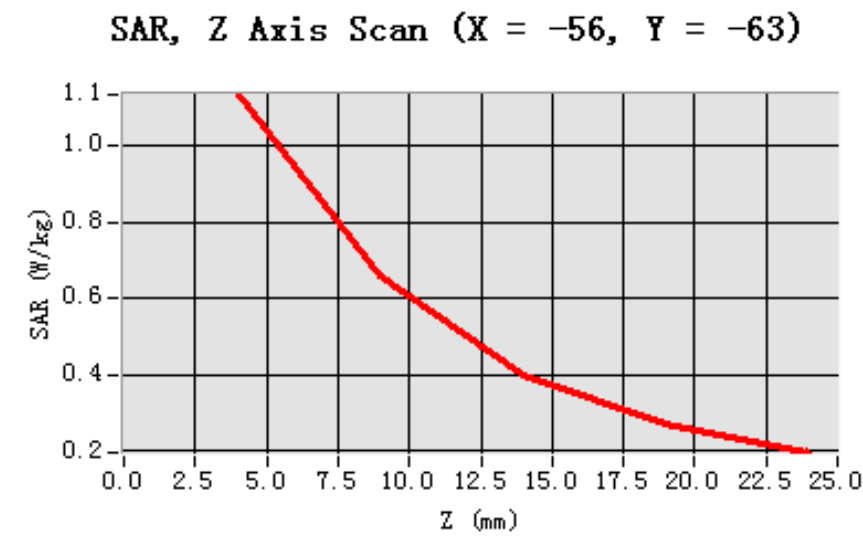

3D screen shot	Hot spot position
<p>A 3D rendering of a human head model. A small rectangular area on the ear is highlighted with a color gradient from blue to red, indicating the location of the hot spot.</p>	<p>A 2D heatmap showing the spatial distribution of SAR. The color scale ranges from blue (low SAR) to red (high SAR). The highest SAR values (red) are concentrated in a localized area, corresponding to the hot spot position shown in the 3D model.</p>

Test Laboratory: AGC Lab

Date: Jan.25,2014

WCDMA Band V High-Body-Towards Grounds (RMC)

DUT: Axe II 3G; Type: Z402

Communication System: UMTS; Communication System Band: BAND V UTRA/FDD; Duty Cycle:1: 1; Conv.F=5.46  
Frequency: 846.6 MHz; Medium parameters used:  $f = 835$  MHz;  $\sigma=0.95$  mho/m;  $\epsilon_r = 55.28$ ;  $\rho = 1000$  kg/m<sup>3</sup> ;  
Phantom section: Flat Section  
Ambient temperature (°C):21, Liquid temperature (°C):21

SATIMO Configuration:

- Probe: EP165; Calibrated: 01/31/2013
- Sensor-Surface: 4mm (Mechanical Surface Detection)
- Phantom: Flat Phantom; Type: Elliptical Phantom
- Measurement SW: OpenSAR V4\_02\_01

Configuration/ WCDMA Band V High-Body-Back/Area Scan (6x8x1): Measurement grid: dx=8mm, dy=8mm  
Configuration/ WCDMA Band V High-Body-Back/Zoom Scan (5x5x7)/Cube 0: Measurement grid: dx=8mm,dy=8mm, dz=5mm;

Area Scan	surf_sam_plan.txt
ZoomScan	5x5x7,dx=8mm dy=8mm dz=5mm,Very fast
Phantom	Validation plane
Device Position	Body Back
Band	WCDMA Band V
Channels	High
Signal	TDMA (Crest factor: 1.0)

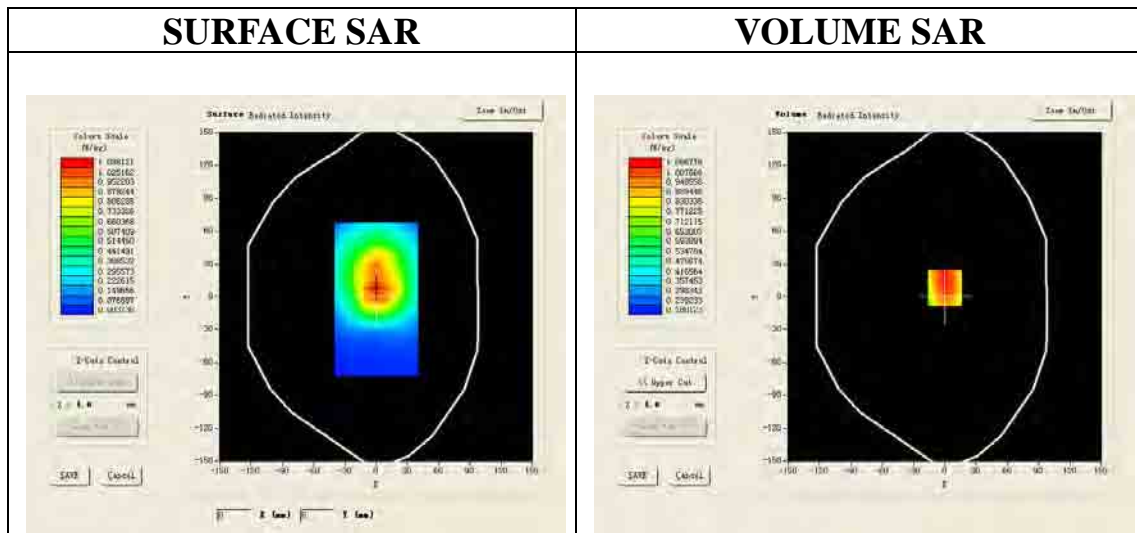

Maximum location: X=0.00, Y=8.00

SAR 10g (W/Kg)	0.755638
SAR 1g (W/Kg)	1.103683

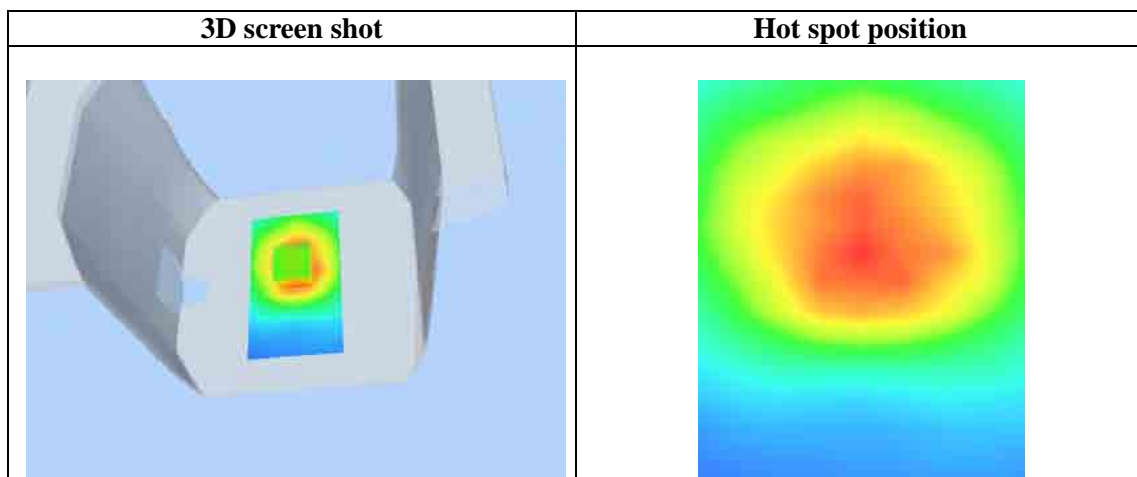
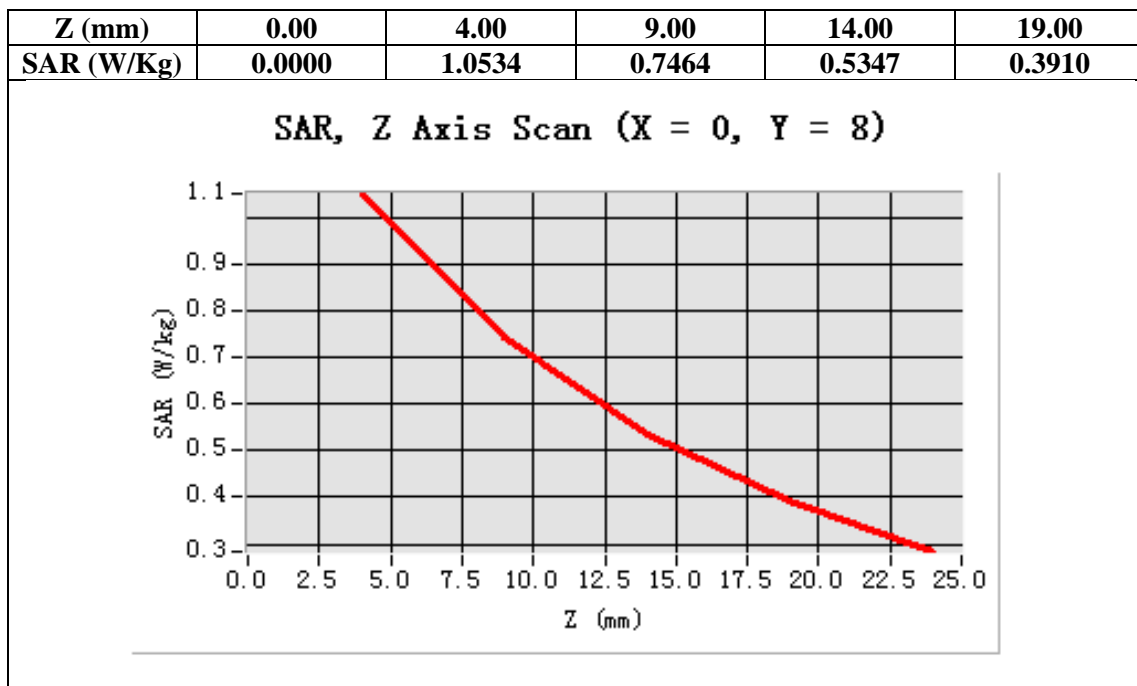

Test Laboratory: AGC Lab

Date: Jan.25,2014

WCDMA Band V High-Body-Towards Grounds (RMC)

DUT: Axe II 3G; Type: Z402

Communication System: UMTS; Communication System Band: BAND V UTRA/FDD; Duty Cycle:1: 1; Conv.F=5.46  
Frequency: 846.6 MHz; Medium parameters used:  $f = 835$  MHz;  $\sigma=0.95$  mho/m;  $\epsilon_r = 55.28$ ;  $\rho = 1000$  kg/m<sup>3</sup> ;  
Phantom section: Flat Section  
Ambient temperature (°C):21, Liquid temperature (°C):21

SATIMO Configuration:

- Probe: EP165; Calibrated: 01/31/2013
- Sensor-Surface: 4mm (Mechanical Surface Detection)
- Phantom: Flat Phantom; Type: Elliptical Phantom
- Measurement SW: OpenSAR V4\_02\_01

Configuration/ WCDMA Band V High-Body-Back/Area Scan (6x8x1): Measurement grid: dx=8mm, dy=8mm  
Configuration/ WCDMA Band V High-Body-Back/Zoom Scan (5x5x7)/Cube 0: Measurement grid: dx=8mm,dy=8mm, dz=5mm;

Area Scan	surf_sam_plan.txt
ZoomScan	5x5x7,dx=8mm dy=8mm dz=5mm,Very fast
Phantom	Validation plane
Device Position	Body Back
Band	WCDMA Band V
Channels	High
Signal	TDMA (Crest factor: 1.0)

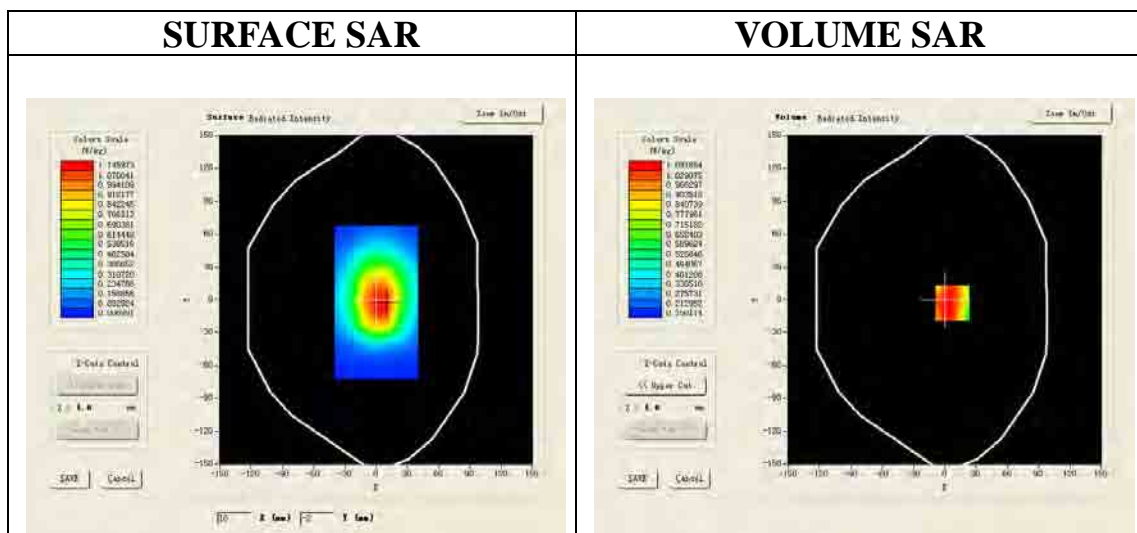

Maximum location: X=7.00, Y=-3.00

SAR 10g (W/Kg)	0.788240
SAR 1g (W/Kg)	1.147117

Z (mm)	0.00	4.00	9.00	14.00	19.00
SAR (W/Kg)	0.0000	1.0841	0.7835	0.5690	0.4162

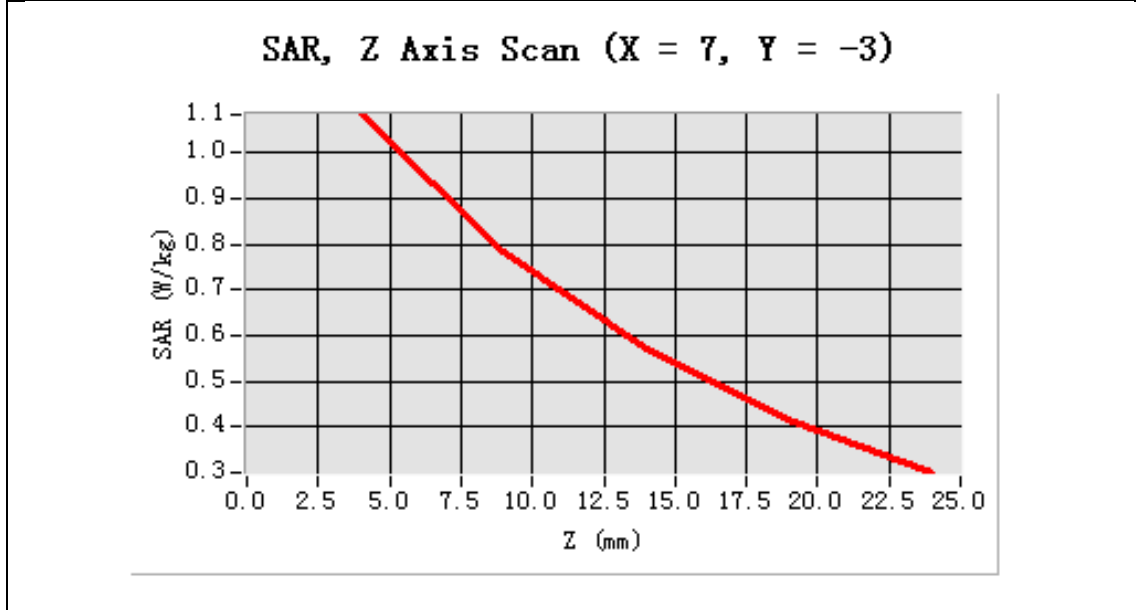

3D screen shot	Hot spot position

Test Laboratory: AGC Lab

Date: Jan.25,2014

WCDMA Band V High- Body - Towards Grounds(HSPA) -with earphone

DUT: Axe II 3G; Type: Z402

Communication System: UMTS; Communication System Band: BAND V UTRA/FDD ; Duty Cycle:1: 1; Conv.F=5.46  
Frequency: 846.6 MHz; Medium parameters used:  $f = 835$  MHz; $\sigma=0.95$  mho/m;  $\epsilon_r =55.28$ ;  $\rho = 1000$ kg/m<sup>3</sup> ;  
Phantom section: Flat Section  
Ambient temperature (°C):21, Liquid temperature (°C):21

SATIMO Configuration:

- Probe: EP165; Calibrated: 01/31/2013
- Sensor-Surface: 4mm (Mechanical Surface Detection)
- Phantom: Flat Phantom; Type: Elliptical Phantom
- Measurement SW: OpenSAR V4\_02\_01

Configuration/ WCDMA Band V High-Body- Back /Area Scan (6x8x1): Measurement grid: dx=8mm, dy=8mm  
Configuration/ WCDMA Band V High-Body- Back /Zoom Scan (5x5x7)/Cube 0: Measurement grid: dx=8mm, dy=8mm, dz=5mm;

Area Scan	surf_sam_plan.txt
ZoomScan	5x5x7,dx=8mm dy=8mm dz=5mm,Very fast
Phantom	Validation plane
Device Position	Body Back
Band	WCDMA Band V
Channels	High
Signal	TDMA (Crest factor: 1.0)

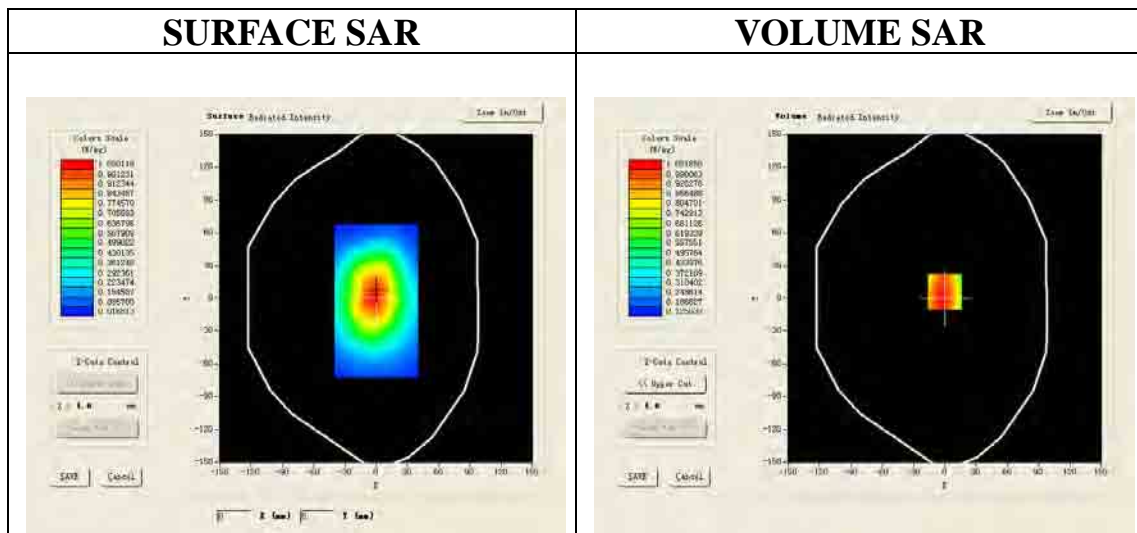

Maximum location: X=0.00, Y=6.00

SAR 10g (W/Kg)	0.718302
SAR 1g (W/Kg)	0.975341

Z (mm)	0.00	4.00	9.00	14.00	19.00
SAR (W/Kg)	0.0000	0.9587	0.6861	0.4593	0.3193

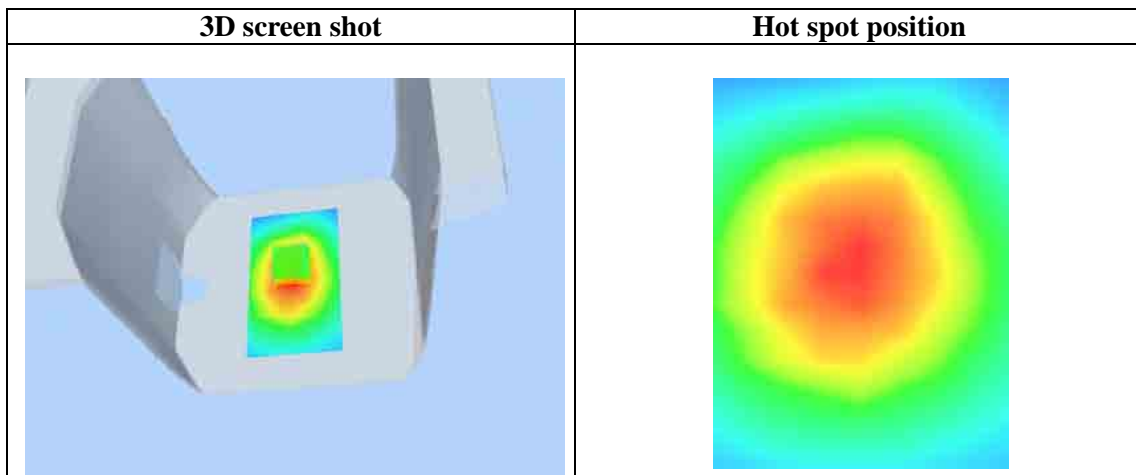
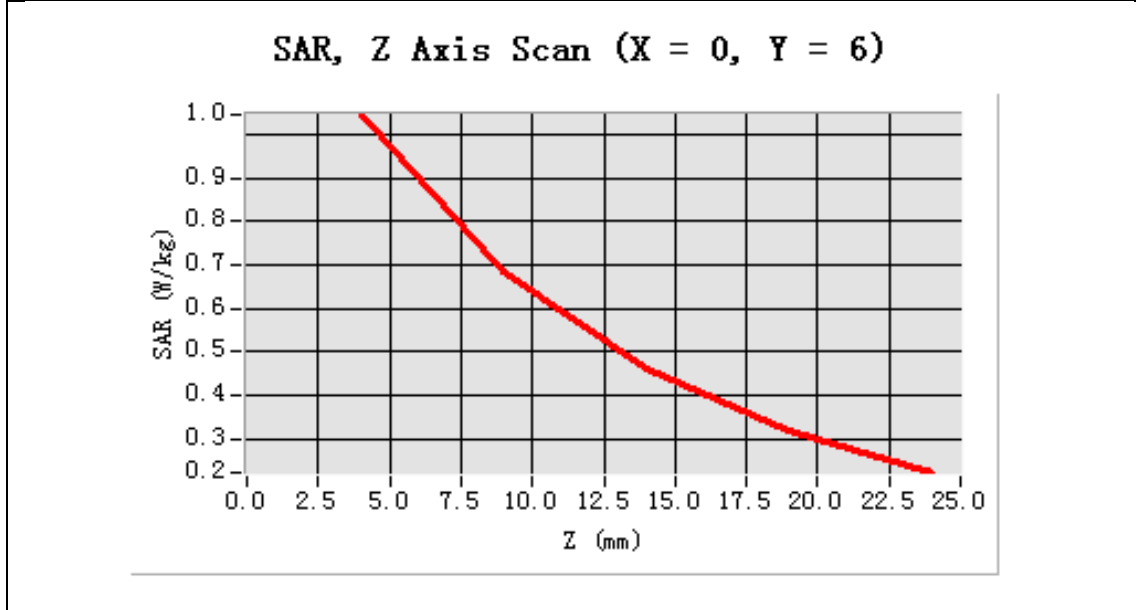



**HOTSPOT MODE**

Test Laboratory: AGC Lab  
Hotspot Mid-Touch-Left

Date: Jan.25,2014

DUT: Axe II 3G; Type: Z402

Communication System: Wi-Fi; Communication System Band: Hotspot; Duty Cycle: 1:1; Conv.F=4.19;  
Frequency: 2437 MHz; Medium parameters used:  $f = 2450$  MHz;  $\sigma = 1.83$  mho/m;  $\epsilon_r = 39.2$ ;  $\rho = 1000$  kg/m<sup>3</sup> ;  
Phantom section: Left Section  
Ambient temperature (°C): 21, Liquid temperature (°C): 21

SATIMO Configuration:

- Probe: EP165; Calibrated: 01/31/2013
- Sensor-Surface: 4mm (Mechanical Surface Detection)
- Phantom: Flat Phantom; Type: Elliptical Phantom
- Measurement SW: OpenSAR V4\_02\_01

Configuration/Hotspot Mid- Touch-Left/Area Scan (6x8x1): Measurement grid: dx=8mm, dy=8mm  
Configuration/Hotspot Mid- Touch-Left/Zoom Scan (5x5x7)/Cube 0: Measurement grid: dx=8mm, dy=8mm, dz=5mm

Area Scan	sam_direct_droit2_surf8mm.txt
ZoomScan	5x5x7,dx=8mm dy=8mm dz=5mm,Very fast
Phantom	Left head
Device Position	Cheek
Band	2450MHz
Channels	Middle
Signal	TDMA (Crest factor: 8.0)

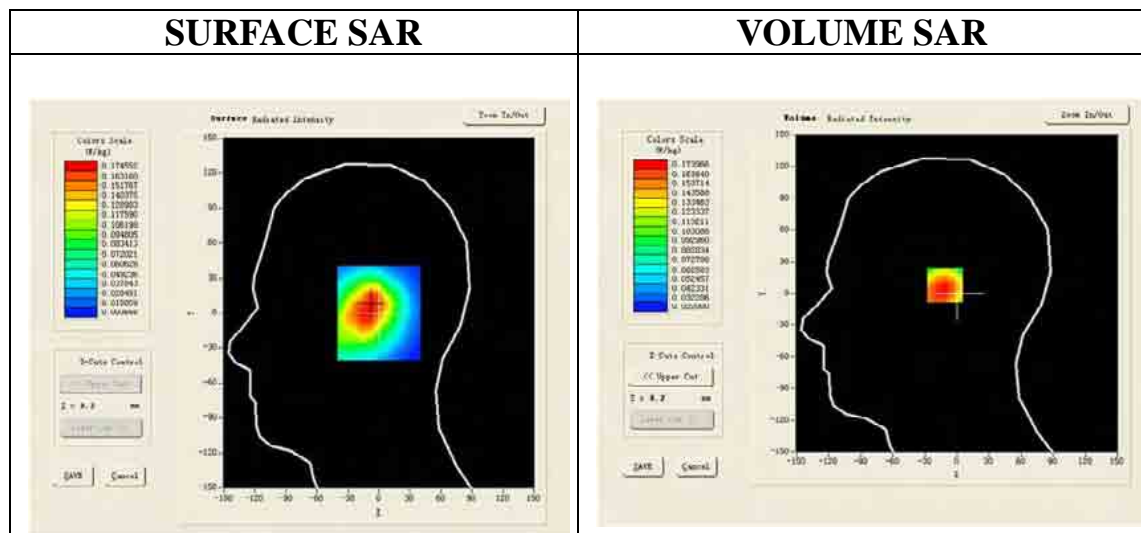

Maximum location: X=-24.00, Y=0.00

SAR 10g (W/Kg)	0.108205
SAR 1g (W/Kg)	0.166953

Z (mm)	0.00	4.00	9.00	14.00	19.00
SAR (W/Kg)	0.0000	0.1716	0.1168	0.0794	0.0550

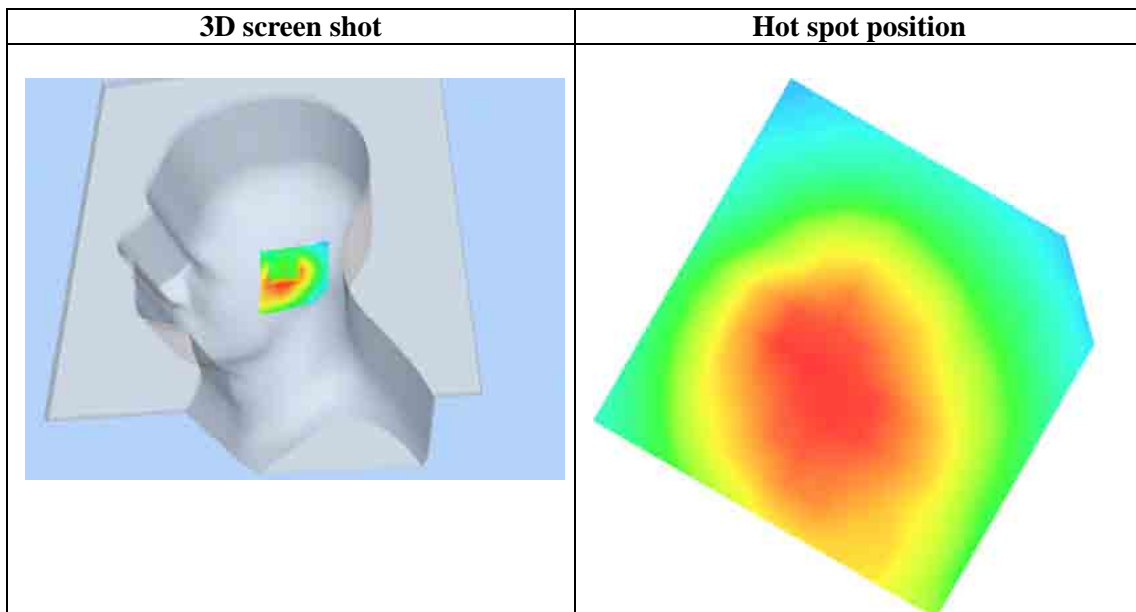
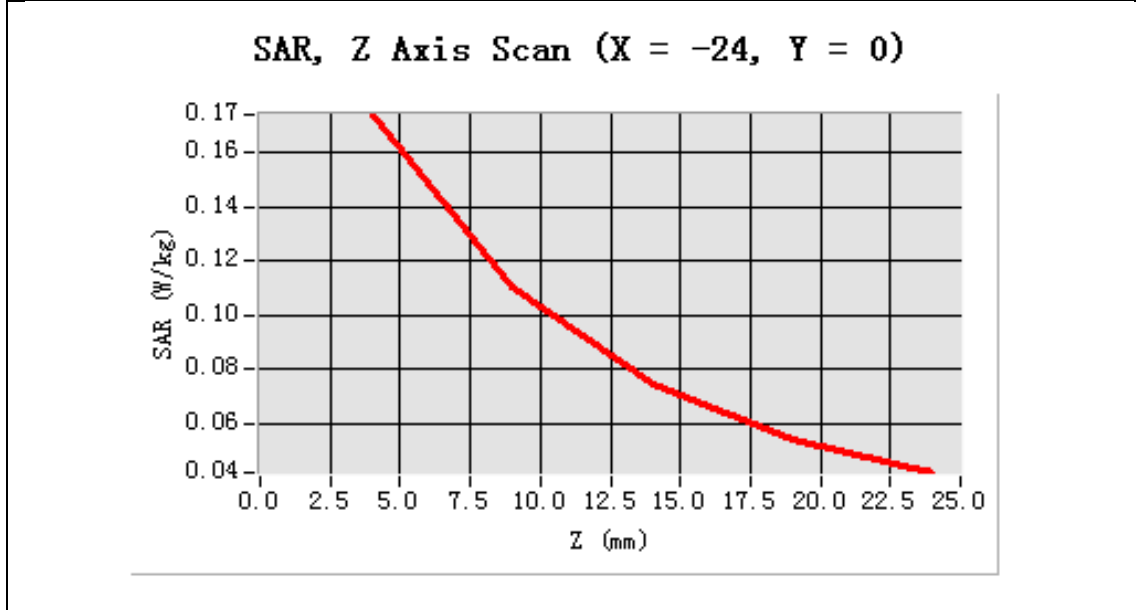

Test Laboratory: AGC Lab  
Hotspot Mid -Tilt-Left  
**DUT: Axe II 3G; Type: Z402**

**Date: Jan.25,2014**

Communication System: Wi-Fi; Communication System Band: Hotspot; Duty Cycle: 1:1; Conv.F=4.19;  
Frequency: 2437 MHz; Medium parameters used:  $f = 2450$  MHz;  $\sigma = 1.83$  mho/m;  $\epsilon_r = 39.2$ ;  $\rho = 1000$  kg/m<sup>3</sup> ;  
Phantom section: Left Section  
Ambient temperature (°C): 21, Liquid temperature (°C): 21

**SATIMO Configuration:**

- Probe: EP165; Calibrated: 01/31/2013
- Sensor-Surface: 4mm (Mechanical Surface Detection)
- Phantom: Flat Phantom; Type: Elliptical Phantom
- Measurement SW: OpenSAR V4\_02\_01

**Configuration/Hotspot Mid- Tilt-Left/Area Scan (6x8x1):** Measurement grid: dx=8mm, dy=8mm  
**Configuration/Hotspot Mid- Tilt-Left/Zoom Scan (5x5x7)/Cube 0:** Measurement grid: dx=8mm, dy=8mm,dz=5mm;

<b>Area Scan</b>	sam_direct_droit2_surf8mm.txt
<b>ZoomScan</b>	5x5x7,dx=8mm dy=8mm dz=5mm,Very fast
<b>Phantom</b>	Left head
<b>Device Position</b>	Tilt
<b>Band</b>	2450MHz
<b>Channels</b>	Middle
<b>Signal</b>	TDMA (Crest factor: 8.0)

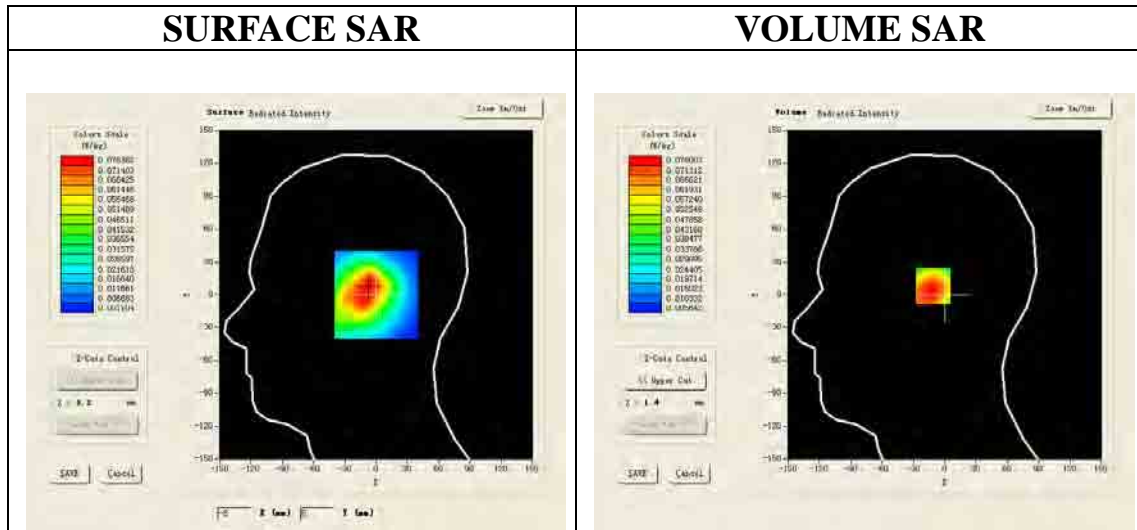

**Maximum location: X=-8.00, Y=8.00**

<b>SAR 10g (W/Kg)</b>	0.046850
<b>SAR 1g (W/Kg)</b>	0.074639

Z (mm)	0.00	4.00	9.00	14.00	19.00
SAR (W/Kg)	0.0000	0.0750	0.0437	0.0349	0.0228

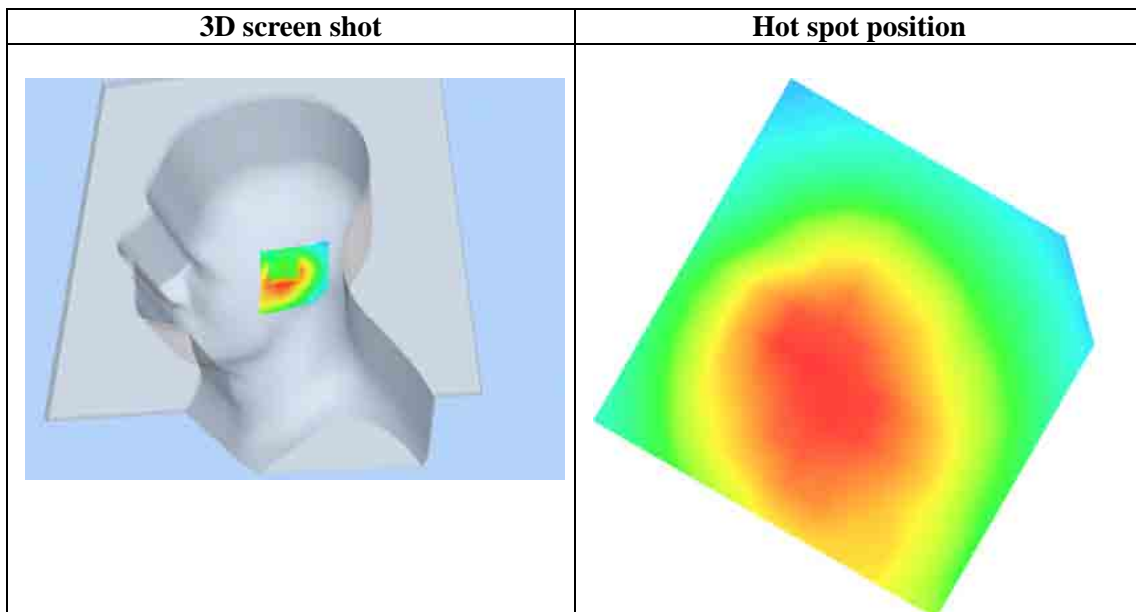
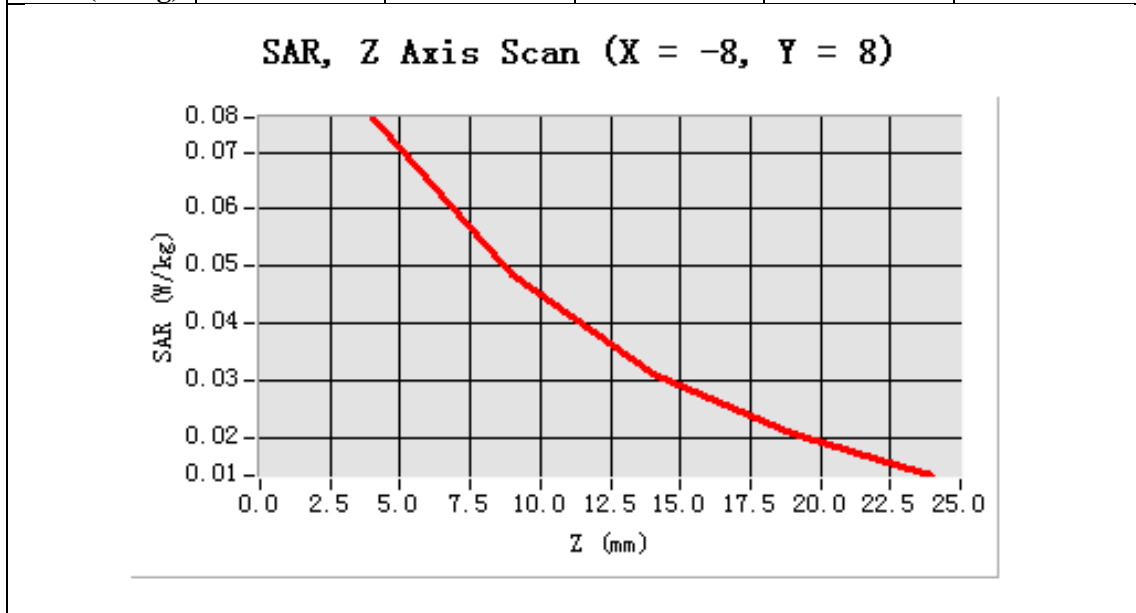

Test Laboratory: AGC Lab  
Hotspot Mid- Touch-Right  
DUT: Axe II 3G; Type: Z402

Date: Jan.25,2014

Communication System: Wi-Fi; Communication System Band: Hotspot; Duty Cycle: 1:1; Conv.F=4.19;  
Frequency: 2437 MHz; Medium parameters used:  $f = 2450$  MHz;  $\sigma = 1.83$  mho/m;  $\epsilon_r = 39.2$ ;  $\rho = 1000$  kg/m<sup>3</sup> ;  
Phantom section: Right Section  
Ambient temperature (°C): 21, Liquid temperature (°C): 21

SATIMO Configuration:

- Probe: EP165; Calibrated: 01/31/2013
- Sensor-Surface: 4mm (Mechanical Surface Detection)
- Phantom: Flat Phantom; Type: Elliptical Phantom
- Measurement SW: OpenSAR V4\_02\_01

Configuration/Hotspot Mid- Touch-Right /Area Scan: Measurement grid: dx=8mm, dy=8mm  
Configuration/Hotspot Mid- Touch-Right /Zoom Scan: Measurement grid: dx=8mm, dy=8mm, dz=5mm;

Area Scan	sam_direct_droit2_surf8mm.txt
ZoomScan	5x5x7,dx=8mm dy=8mm dz=5mm,Very fast
Phantom	Right head
Device Position	Cheek
Band	2450MHz
Channels	Middle
Signal	TDMA (Crest factor: 8.0)

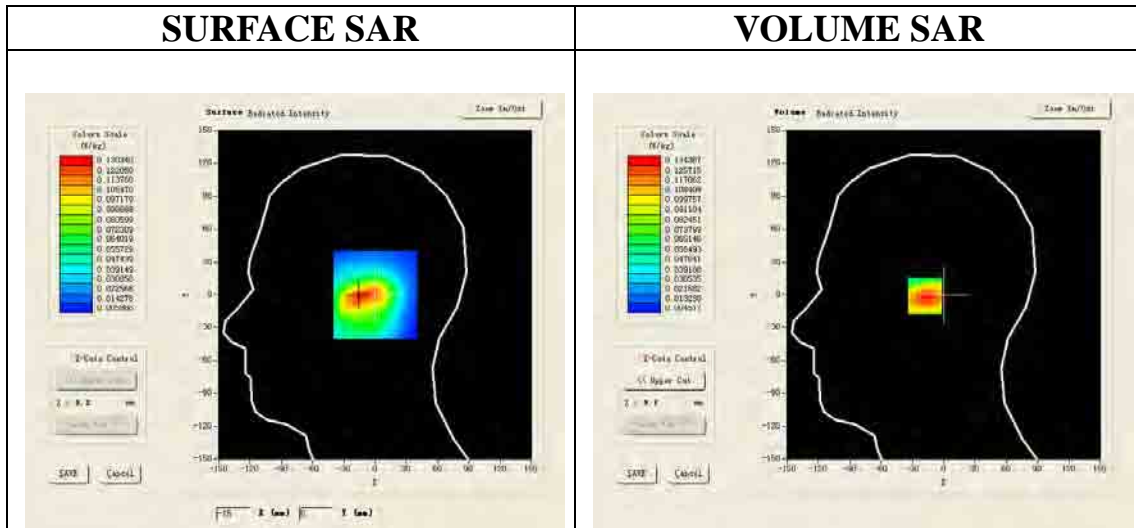

Maximum location: X=-15.00, Y=-1.00

SAR 10g (W/Kg)	0.076175
SAR 1g (W/Kg)	0.122980

Z (mm)	0.00	4.00	9.00	14.00	19.00
SAR (W/Kg)	0.0000	0.1364	0.0782	0.0339	0.0273

**SAR, Z Axis Scan (X = -15, Y = -1)**

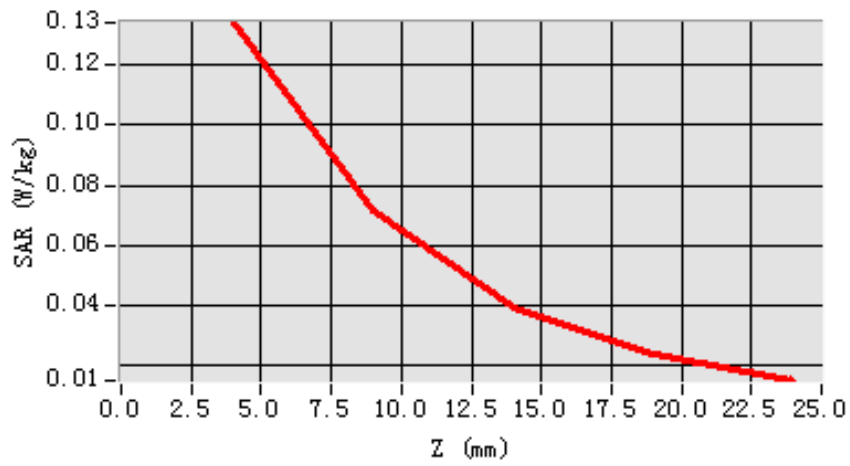

**3D screen shot**

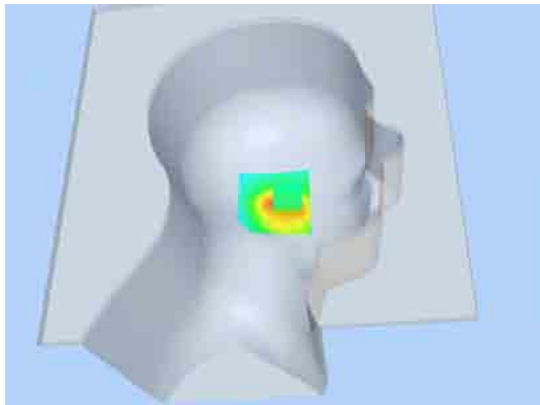

**Hot spot position**

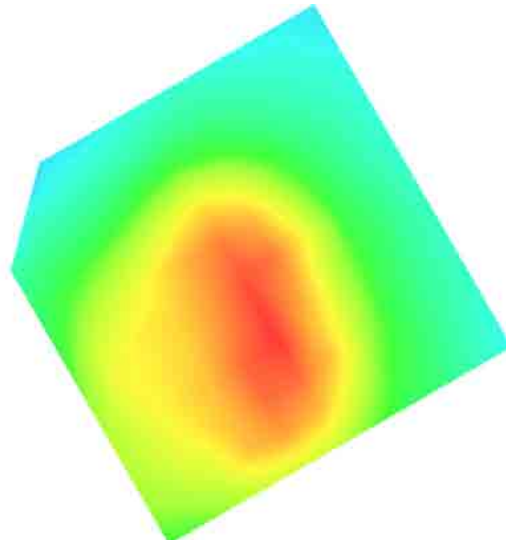

Test Laboratory: AGC Lab  
Hotspot Mid-Tilt-Right  
**DUT: Axe II 3G; Type: Z402**

**Date: Jan.25,2014**

Communication System: Wi-Fi; Communication System Band: Hotspot; Duty Cycle: 1:1; Conv.F=4.19;  
Frequency: 2437 MHz; Medium parameters used:  $f = 2450$  MHz;  $\sigma = 1.83$  mho/m;  $\epsilon_r = 39.2$ ;  $\rho = 1000$  kg/m<sup>3</sup> ;  
Phantom section: Right Section  
Ambient temperature (°C): 21, Liquid temperature (°C): 21

**SATIMO Configuration:**

- Probe: EP165; Calibrated: 01/31/2013
- Sensor-Surface: 4mm (Mechanical Surface Detection)
- Phantom: Flat Phantom; Type: Elliptical Phantom
- Measurement SW: OpenSAR V4\_02\_01

**Configuration/Hotspot Mid- Tilt-Right/Area Scan:** Measurement grid: dx=8mm, dy=8mm  
**Configuration/Hotspot Mid- Tilt-Right/Zoom Scan:** Measurement grid: dx=8mm, dy=8mm, dz=5mm;

<b>Area Scan</b>	sam_direct_droit2_surf8mm.txt
<b>Zoom Scan</b>	5x5x7,dx=8mm dy=8mm dz=5mm,Very fast
<b>Phantom</b>	Right head
<b>Device Position</b>	Tilt
<b>Band</b>	2450MHz
<b>Channels</b>	Middle
<b>Signal</b>	TDMA (Crest factor: 8.0)

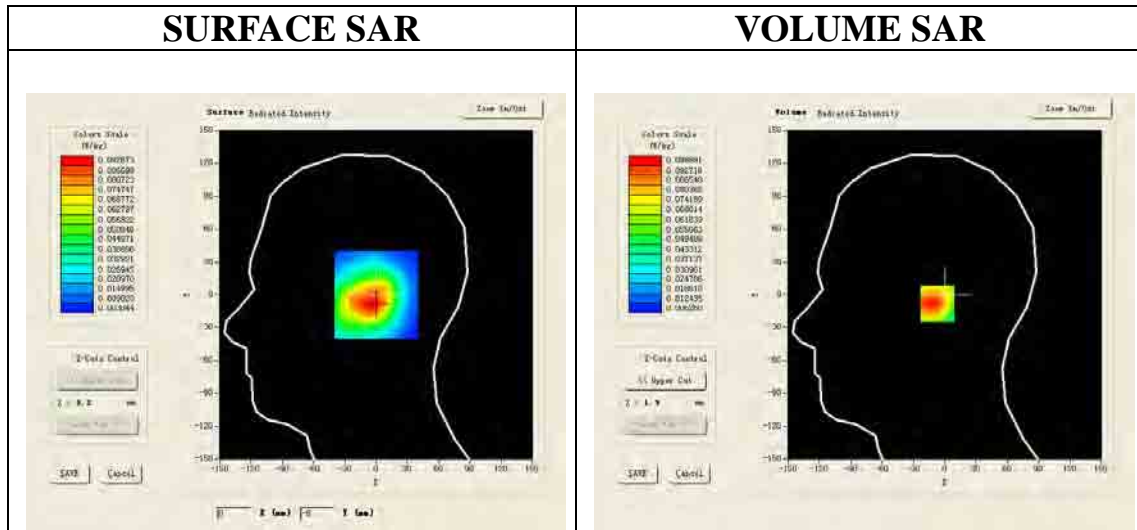

**Maximum location: X=-2.00, Y=-8.00**

<b>SAR 10g (W/Kg)</b>	0.056938
<b>SAR 1g (W/Kg)</b>	0.095082

Z (mm)	0.00	4.00	9.00	14.00	19.00
SAR (W/Kg)	0.0000	0.0949	0.0638	0.0388	0.0261

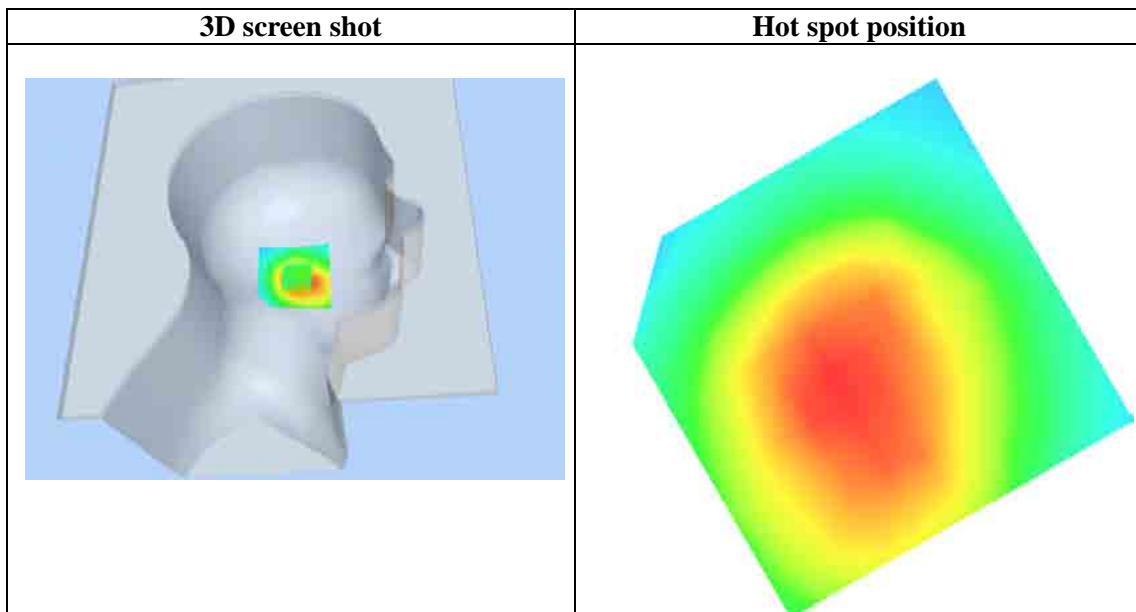
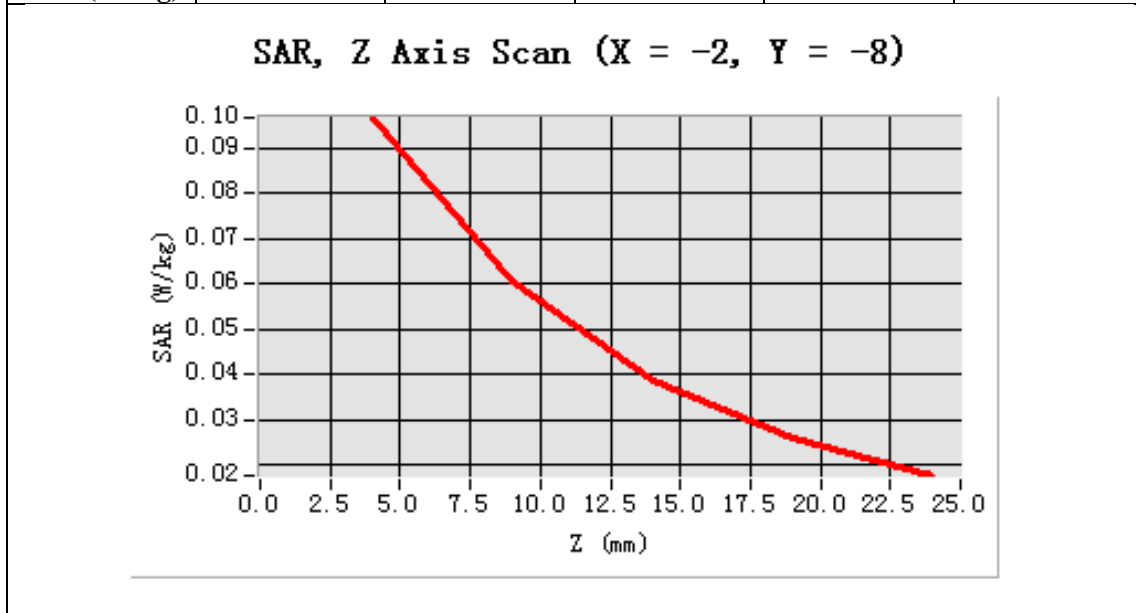



Test Laboratory: AGC Lab  
Hotspot Mid-Body-Worn- Back (DTS)  
DUT: **Axe II 3G**; Type: **Z402**

Date: **Jan.25,2014**

Communication System: Wi-Fi; Communication System Band: Hotspot; Duty Cycle: 1:1; Conv.F=4.32;  
Frequency: 2437 MHz; Medium parameters used:  $f = 2450$  MHz;  $\sigma = \sigma_F$  mho/m;  $\epsilon_r = 52.27$ ;  $\rho = 1000$  kg/m<sup>3</sup> ;  
Phantom section: Flat Section  
Ambient temperature (°C):21, Liquid temperature (°C):21

SATIMO Configuration:

- Probe: EP165; Calibrated: 01/31/2013
- Sensor-Surface: 4mm (Mechanical Surface Detection)
- Phantom: Flat Phantom; Type: Elliptical Phantom
- Measurement SW: OpenSAR V4\_02\_01

**Configuration/Hotspot Mid- Body- Back /Area Scan (6x8x1):** Measurement grid: dx=8mm, dy=8mm  
**Configuration/Hotspot Mid- Body- Back /Zoom Scan (5x5x7)/Cube 0:** Measurement grid: dx=8mm, dy=8mm, dz=5mm;

<b>Area Scan</b>	surf_sam_plan.txt
<b>ZoomScan</b>	5x5x7,dx=8mm dy=8mm dz=5mm,Very fast
<b>Phantom</b>	Validation plane
<b>Device Position</b>	Body Back
<b>Band</b>	2450MHz
<b>Channels</b>	Middle
<b>Signal</b>	TDMA (Crest factor: 8.0)

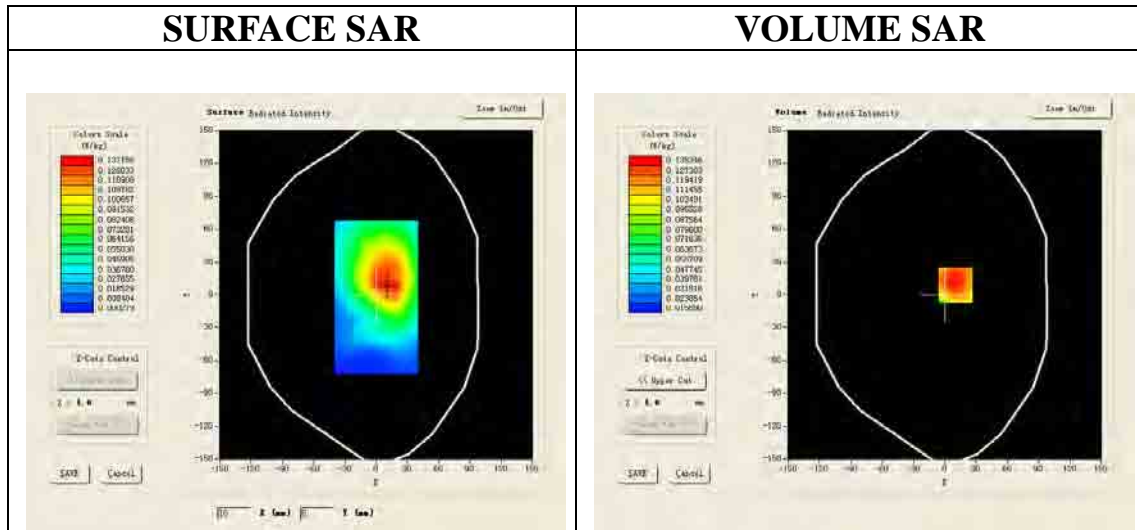

**Maximum location: X=10.00, Y=9.00**

<b>SAR 10g (W/Kg)</b>	0.086935
<b>SAR 1g (W/Kg)</b>	0.135072

Z (mm)	0.00	4.00	9.00	14.00	19.00
SAR (W/Kg)	0.0000	0.1346	0.0939	0.0641	0.0476

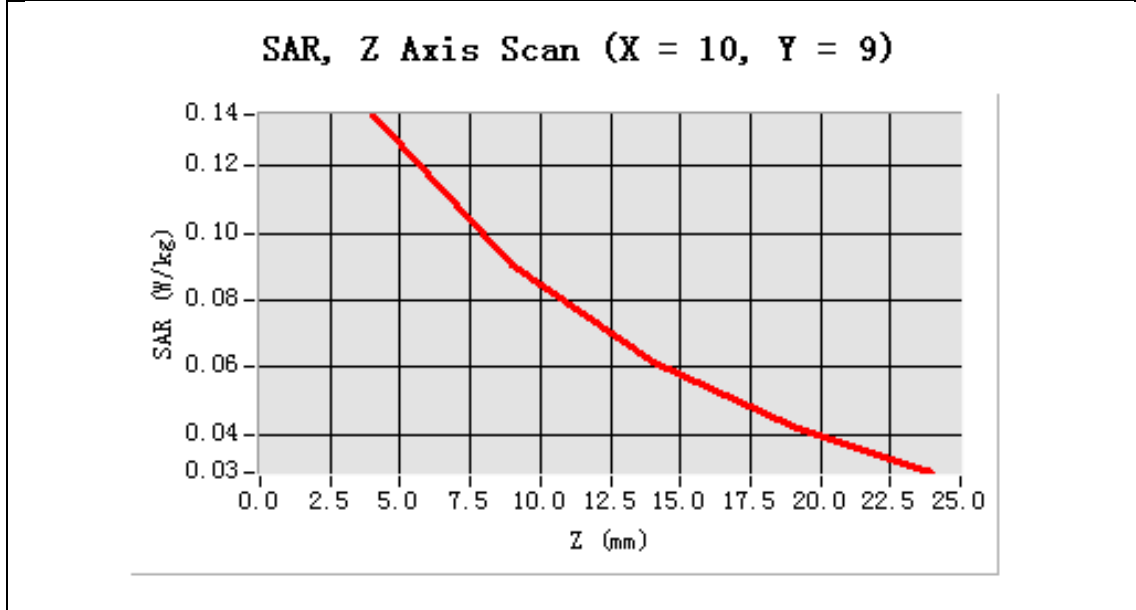

3D screen shot	Hot spot position

Test Laboratory: AGC Lab  
Hotspot Mid-Body -Front (DTS)  
DUT: **Axe II 3G**; Type: **Z402**

Date: **Jan.25,2014**

Communication System: Wi-Fi; Communication System Band: Hotspot; Duty Cycle: 1:1; Conv.F=4.32;  
Frequency: 2437 MHz; Medium parameters used:  $f = 2450$  MHz;  $\sigma = \sigma_F$  mho/m;  $\epsilon_r = 52.27$ ;  $\rho = 1000$  kg/m<sup>3</sup> ;  
Phantom section: Flat Section  
Ambient temperature (°C):21, Liquid temperature (°C):21

SATIMO Configuration:

- Probe: EP165; Calibrated: 01/31/2013
- Sensor-Surface: 4mm (Mechanical Surface Detection)
- Phantom: Flat Phantom; Type: Elliptical Phantom
- Measurement SW: OpenSAR V4\_02\_01

**Configuration/Hotspot Mid-Body- Front /Area Scan:** Measurement grid: dx=8mm, dy=8mm  
**Configuration/Hotspot Mid-Body- Front /Zoom Scan:** Measurement grid: dx=8mm, dy=8mm, dz=5mm;

<b>Area Scan</b>	surf_sam_plan.txt
<b>ZoomScan</b>	5x5x7,dx=8mm dy=8mm dz=5mm,Very fast
<b>Phantom</b>	Validation plane
<b>Device Position</b>	Body Front
<b>Band</b>	2450MHz
<b>Channels</b>	Middle
<b>Signal</b>	TDMA (Crest factor: 8.0)

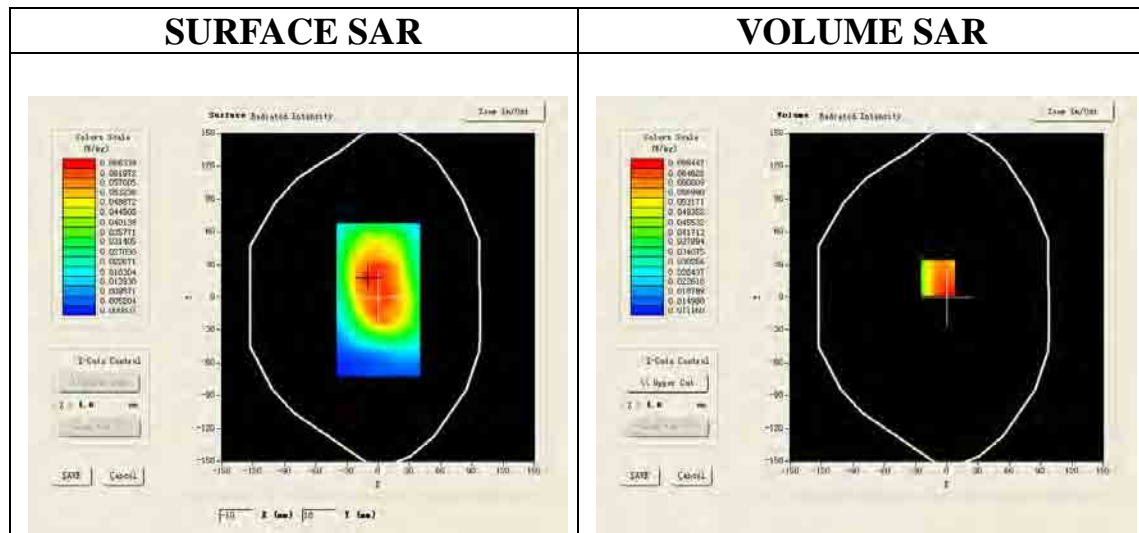

**Maximum location: X=-9.00, Y=18.00**

<b>SAR 10g (W/Kg)</b>	0.049350
<b>SAR 1g (W/Kg)</b>	0.067493

Z (mm)	0.00	4.00	9.00	14.00	19.00
SAR (W/Kg)	0.0000	0.0628	0.0496	0.0306	0.0225

