



Test Report

Product	13.56MHz RFID Encoder	
Name and address of the applicant	ASSA ABLOY Hospitality AS Anolitveien 1-3, 1400 Ski, Norway	
Name and address of the manufacturer	ASSA ABLOY Hospitality AS Anolitveien 1-3, 1400 Ski, Norway	
Model	RFID Encoder and updater	
Rating	Primary voltage: 100 - 230V 60Hz AC/DC adapter or USB power or PoE Secondary voltage: 5Vdc	
Trademark	ASSA ABLOY	
Serial number	/	
Additional information	RFID -13.56MHz	
Tested according to	FCC Part 15.225 Low Power Transmitter 13.110 - 14.010 MHz Band Industry Canada RSS-210, Issue 8 Low Power Licence-Exempt Radiocommunications Devices	
Order number	296480	
Tested in period	2015.11.10 - 2015.11.14, 2016.02.23 & 2016.02.12	
Issue date	2016.06.27	
Name and address of the testing laboratory	 FCC No: 994405 IC OATS: 2040D-1 Instituttveien 6 Kjeller, Norway TEL: +47 22 96 03 30 FAX: +47 22 96 05 50	
	 Prepared by [G.Suhanthakumar]	 Approved by [Frode Sveinsen]
This report shall not be reproduced except in full without the written approval of Nemko. Opinions and interpretations expressed within this report are not part of the current accreditation. This report was originally distributed electronically with digital signatures. For more information contact Nemko.		

CONTENTS

1	INFORMATION	3
1.1	Test Item	3
1.2	Test Environment	4
1.2.1	Normal test condition	4
1.3	Test Engineer(s)	4
1.4	Test Equipment	4
2	TEST REPORT SUMMARY	5
2.1	General	5
2.2	Test Summary	6
2.3	Description of modification for Modification Filing	6
2.4	Comments	6
2.5	Family List Rational	6
3	TEST RESULTS.....	7
3.1	Occupied Bandwidth	7
3.2	Power Line Conducted Emissions	9
3.3	Peak power output	26
3.4	Spurious emissions (radiated)	29
3.5	Transmitter Frequency Stability	43
4	Measurement Uncertainty	44
5	LIST OF TEST EQUIPMENT.....	45
6	BLOCK DIAGRAM	46
6.1	System set up for radiated measurements	46
6.2	Test Site Radiated Emission.....	47

1 INFORMATION

1.1 Test Item

Name :	ASSA ABLOY
FCC ID :	Y7V-681001025C1
Industry Canada ID :	9514A-681001025C1
Model/version :	RFID Encoder and updater
Serial number :	/
Hardware identity and/or version:	681001025R3
Software identity and/or version :	/
Frequency Range :	13.553-13.567 MHz
Tunable Bands :	None
Number of Channels :	1
Operating Modes :	Transmitter
Type of Modulation :	ISO 14443-A
User Frequency Adjustment :	None
Type of Power Supply :	5 Vdc
Antenna Connector :	Integral loop antenna
Antenna Diversity Supported :	None
Desktop Charger :	None

Description of Test Item

The RFID encoder is for encoding, verification and auto-update of RFID cards. It operates at 13.56MHz. This RFID encoder can be powered via USB, via PoE (power over Ethernet) or external AC/DC power adapter.

1.2 Test Environment

1.2.1 Normal test condition

Temperature:	20 - 24 °C
Relative humidity:	20 - 50 %
Normal test voltage:	120Vac

The values are the limit registered during the test period.

1.3 Test Engineer(s)

G.Suhanthakumar

1.4 Test Equipment

See list of test equipment in clause 5.

2 TEST REPORT SUMMARY

2.1 General

All measurements are traceable to national standards.

The tests were conducted for the purpose of demonstrating compliance with FCC CFR 47 Part 15, paragraph 15.225 and Industry Canada RSS-210 Issue 8.

Tests were performed in accordance with ANSI C63.4-2014 and ANSI C63.10-2013.

Radiated tests were made in a semi-anechoic chamber at measuring distances of 3m and 10m.

A description of the test facility is on file with the FCC and Industry Canada.

New Submission

Production Unit

Class II Permissive Change

Pre-production Unit

DXX Equipment Code

Family Listing



THIS TEST REPORT APPLIES ONLY TO THE ITEM(S) AND CONFIGURATIONS TESTED.

Deviations from, additions to, or exclusions from the test specifications are described in "Summary of Test Data".

Nemko Group authorizes the above named company to reproduce this report provided it is reproduced in its entirety and for use by the company's employees only. Any reproduction of parts of this report requires approval in writing from Nemko Group.

Any use which a third party makes of this report, or any reliance on or decisions to be made based on it, are the responsibility of such third parties. Nemko Group accepts no responsibility for damages suffered by any third party as a result of decisions made or actions based on this report.

2.2 Test Summary

Name of test	FCC Part 15 reference	RSS-210 Issue 8 & RSS-GEN Issue 4	Result
Supply Voltage Variations	15.31(e)	N/A	Complies ¹
Antenna Requirement	15.203	7.1.4 (RSS-GEN)	NA ²
Power-line Conducted Emission	15.207(c)	7.2.2 (RSS-GEN)	Complies
Occupied Bandwidth	N/A	4.6.1 (RSS-GEN)	-
Peak Power Output	15.225(a)	A2.6	Complies
Band Emissions	15.225(b)(c)	A.2.6(b)(c)	Complies
Spurious Emissions (Radiated)	15.225 (d) 15.209	A2.6(d) 4.9 (RSS-GEN)	Complies
Frequency stability	15.225(e)	A2.6	Complies

¹ Integral loop antenna

RSS Gen issue 4 covers section 7 & 6

RSS 210 issue 8 covers section A2.9

2.3 Description of modification for Modification Filing

Not applicable.

2.4 Comments

And the output level is set to maximum in the software.

The radiated measurements are tested on three axis.

The measurements were done with the EUT powered by 120 V AC. It was checked that power variations between 85% and 115% did not have any influence on the measurements.

All ports were populated during spurious emission measurements.

2.5 Family List Rational

Not Applicable.

3 TEST RESULTS

3.1 Occupied Bandwidth

Para. No.: RSS-Gen

Test Performed By: G.Suhandhakumar	Date of Test: 23-oct-2015
------------------------------------	---------------------------

Test Results: Complies

Measurement Data:

OBW (kHz)
13.56MHz
16.7

Requirements:

For information only



*RBW 10 kHz Delta 1 [T1]
 VBW 30 kHz 0.01 dB
 SWI 5 ms 16.666666667 kHz

Ref 46 dBµV/m *Att 10 dB

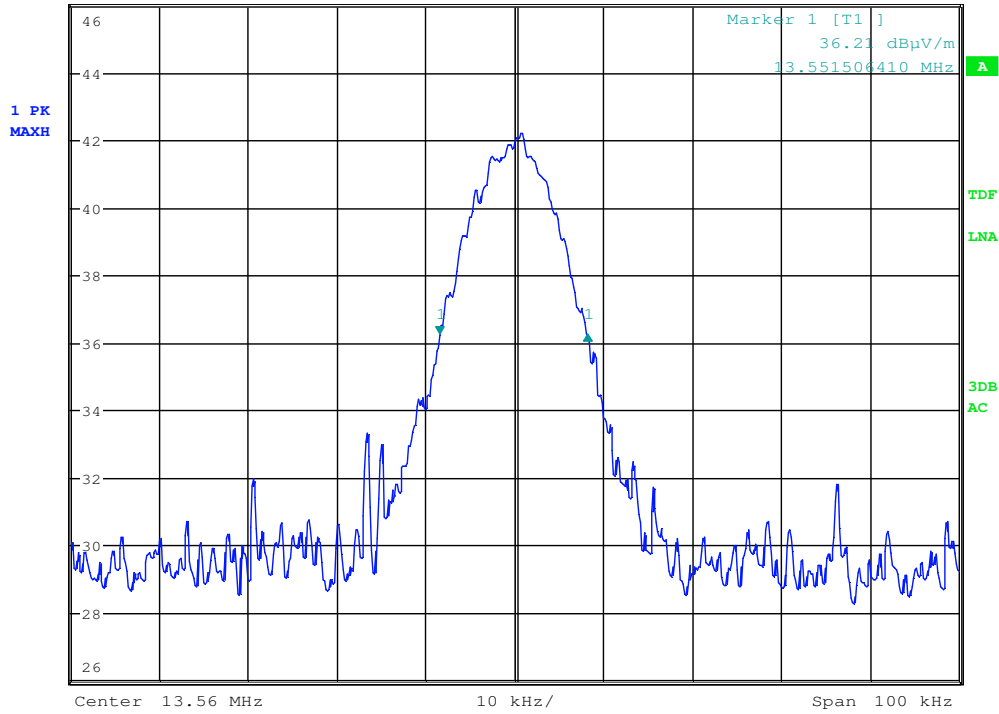

Date: 23.OCT.2015 11:27:48

13.56MHz – OBW – 16.7kHz

3.2 Power Line Conducted Emissions

Para. No.: 15.207 (a)

Test Performed By: G.Suhanthakumar	Date of Test: 14.Nov.2015 & 12. May.2016
------------------------------------	------------------------------------------

Measurement procedure: ANSI C63.4-2014 using 50 μ H/50 ohms LISN.

Test Results: Complies.

Measurement Data: See attached graph, (Peak detector).

Measured with all type of primary powers are used.

AC/DC adapter, CMP, Model: S008CM0500120

PoE switch: Netgear FS108P, S/N: 2HK11B3W00AB

Lap Top: ASUS, S/N: A70AAS310071

With AC/DC adapter, 120Vac,60Hz; with dummy load (measured as described in ANSI C63.10-2013 and KDB 174176 D01)

Dummy load: 0,5 Ω + 2,4 μ H

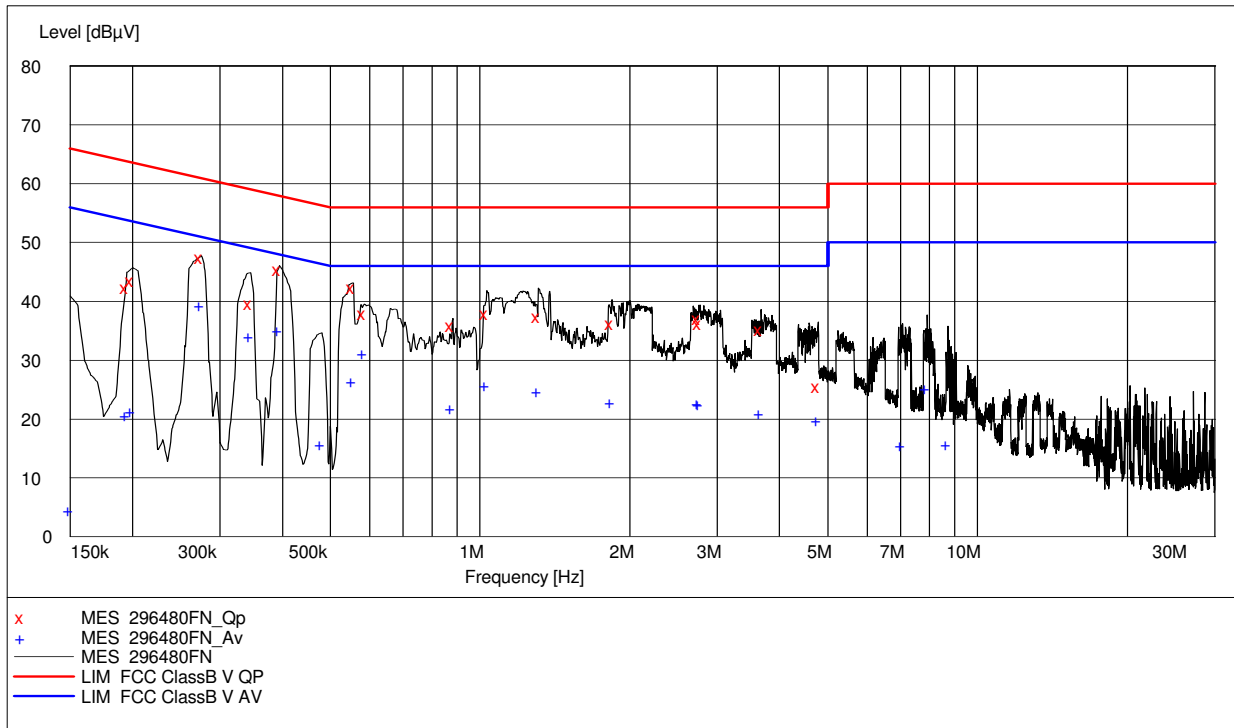

Fundamental emission band 13.110MHz – 14.010MHz (with dummy load)

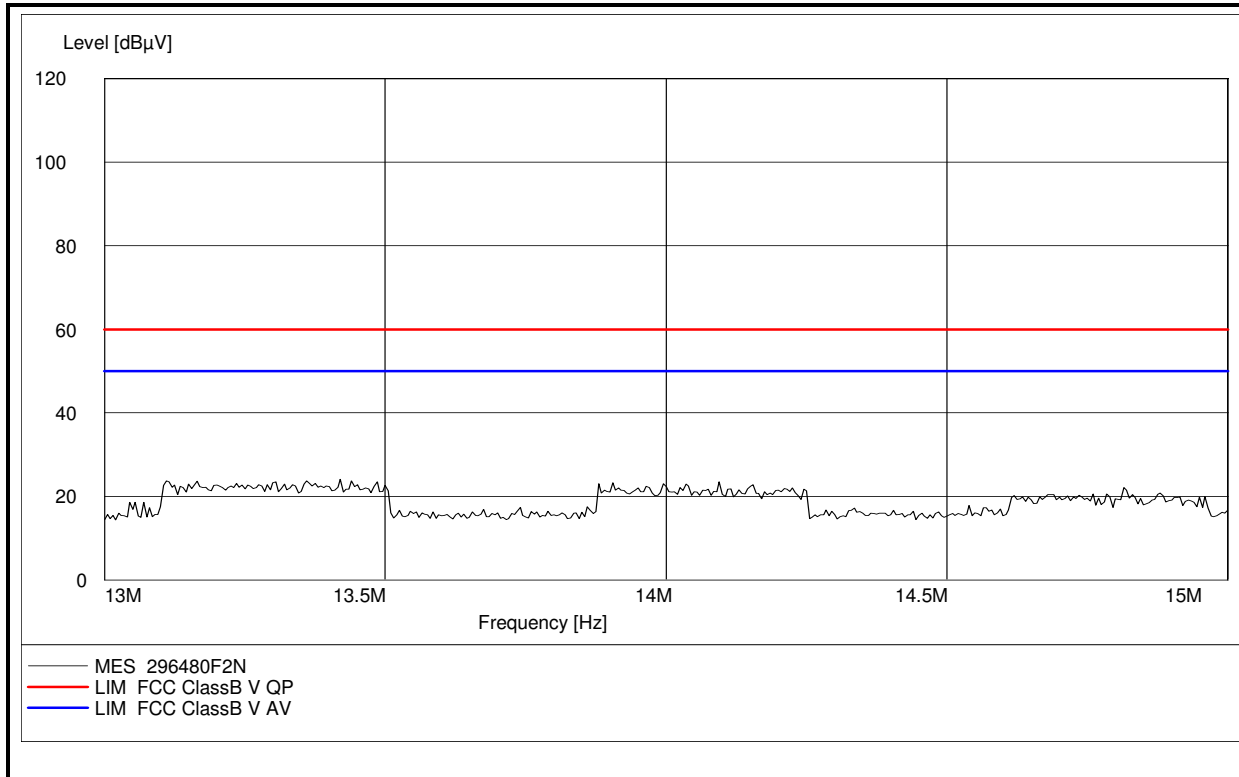

With QP detector:

Frequency [MHz]	Level [dBuV]	Af [dB]	Limit [dBuV]	Margin [dB]	Det	Position	Verdict [Pass/Fail]
0.195000	42.40	10.70	63.80	21.40	QP	N	Pass
0.200000	43.60	10.70	63.60	20.00	QP	N	Pass
0.275000	47.40	10.60	61.00	13.60	QP	L1	Pass
0.345000	39.70	10.40	59.10	19.40	QP	L1	Pass
0.395000	45.50	10.40	58.00	12.50	QP	L1	Pass
0.555000	42.40	10.20	56.00	13.60	QP	L1	Pass
0.585000	38.00	10.20	56.00	18.00	QP	L1	Pass
0.880000	35.90	10.30	56.00	20.10	QP	L1	Pass
1.030000	38.00	10.40	56.00	18.00	QP	L1	Pass
1.310000	37.40	10.40	56.00	18.60	QP	L1	Pass
1.845000	36.20	10.40	56.00	19.80	QP	L1	Pass
2.750000	37.10	10.40	56.00	18.90	QP	L1	Pass
2.770000	36.30	10.40	56.00	19.70	QP	L1	Pass
3.670000	35.20	10.40	56.00	20.80	QP	L1	Pass
4.780000	25.50	10.50	56.00	30.50	QP	L1	Pass

With AV detector:

Frequency [MHz]	Level [dBuV]	Af [dB]	Limit [dBuV]	Margin [dB]	Det	Position	Verdict [Pass/Fail]
0.150000	4.60	10.70	56.00	51.40	AV	N	Pass
0.195000	20.70	10.70	53.80	33.10	AV	N	Pass
0.200000	21.50	10.70	53.60	32.10	AV	N	Pass
0.275000	39.40	10.60	51.00	11.60	AV	L1	Pass
0.345000	34.30	10.40	49.10	14.80	AV	L1	Pass
0.395000	35.20	10.40	48.00	12.80	AV	L1	Pass
0.480000	15.90	10.30	46.30	30.40	AV	N	Pass
0.555000	26.60	10.20	46.00	19.40	AV	L1	Pass
0.585000	31.30	10.20	46.00	14.70	AV	L1	Pass
0.880000	21.90	10.30	46.00	24.10	AV	L1	Pass
1.030000	25.80	10.40	46.00	20.20	AV	L1	Pass
1.310000	24.80	10.40	46.00	21.20	AV	L1	Pass
1.845000	23.10	10.40	46.00	22.90	AV	L1	Pass
2.750000	22.90	10.40	46.00	23.10	AV	L1	Pass
2.770000	22.70	10.40	46.00	23.30	AV	L1	Pass
3.670000	21.20	10.40	46.00	24.80	AV	L1	Pass
4.780000	19.90	10.50	46.00	26.10	AV	L1	Pass
7.070000	15.60	10.60	50.00	34.40	AV	L1	Pass
7.925000	25.40	10.60	50.00	24.60	AV	N	Pass
8.720000	15.90	10.60	50.00	34.10	AV	N	Pass

With AC/DC adapter, 120Vac,60Hz : Loop antenna (integral)

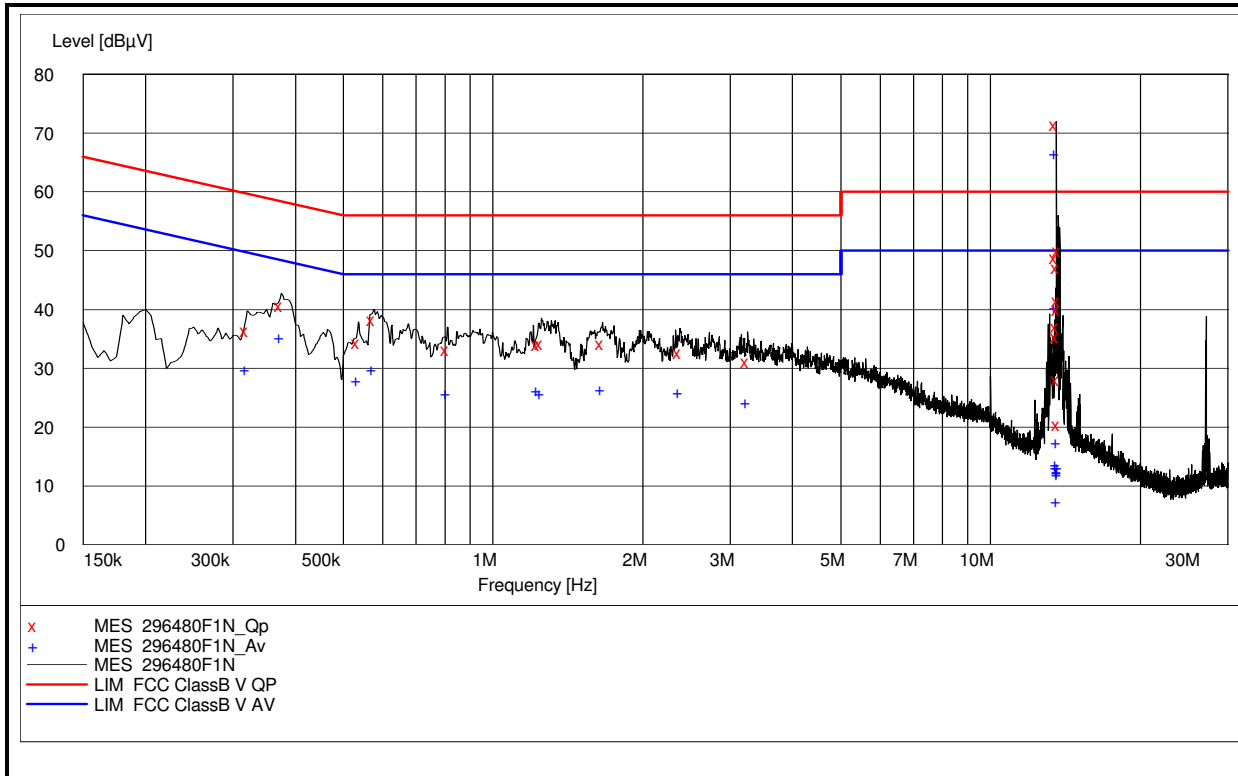

With QP detector:

Frequency [MHz]	Level [dBuV]	Af [dB]	Limit [dBuV]	Margin [dB]	Det	Position	Verdict [Pass/Fail]
0.320000	36.50	10.50	59.70	23.20	QP	L1	Pass
0.375000	40.70	10.40	58.40	17.70	QP	L1	Pass
0.535000	34.40	10.20	56.00	21.60	QP	L1	Pass
0.575000	38.30	10.20	56.00	17.70	QP	L1	Pass
0.810000	33.10	10.20	56.00	22.90	QP	L1	Pass
1.235000	34.10	10.40	56.00	21.90	QP	L1	Pass
1.250000	34.30	10.40	56.00	21.70	QP	L1	Pass
1.660000	34.30	10.40	56.00	21.70	QP	L1	Pass
2.375000	32.70	10.40	56.00	23.30	QP	L1	Pass
3.250000	31.20	10.40	56.00	24.80	QP	L1	Pass
13.550000	48.90	10.80	60.00	11.10	QP	L1	Pass
13.560000	71.50	10.80	60.00	-11.50	QP	N	Wanted signal
13.620000	35.50	10.80	60.00	24.50	QP	N	Pass
13.635000	37.10	10.80	60.00	22.90	QP	L1	Pass
13.665000	28.10	10.80	60.00	31.90	QP	N	Pass
13.680000	47.20	10.80	60.00	12.80	QP	L1	Pass
13.695000	41.60	10.80	60.00	18.40	QP	N	Pass
13.705000	40.00	10.80	60.00	20.00	QP	L1	Pass
13.730000	20.50	10.80	60.00	39.50	QP	L1	Pass
13.770000	50.10	10.80	60.00	9.90	QP	L1	Pass

With AV detector:

Frequency [MHz]	Level [dBuV]	Af [dB]	Limit [dBuV]	Margin [dB]	Det	Position	Verdict [Pass/Fail]
0.320000	30.00	10.50	49.70	19.70	AV	L1	Pass
0.375000	35.40	10.40	48.40	13.00	AV	L1	Pass
0.535000	28.10	10.20	46.00	17.90	AV	L1	Pass
0.575000	30.00	10.20	46.00	16.00	AV	L1	Pass
0.810000	25.90	10.20	46.00	20.10	AV	L1	Pass
1.235000	26.50	10.40	46.00	19.50	AV	L1	Pass
1.250000	25.90	10.40	46.00	20.10	AV	L1	Pass
1.660000	26.70	10.40	46.00	19.30	AV	L1	Pass
2.375000	26.00	10.40	46.00	20.00	AV	L1	Pass
3.250000	24.40	10.40	46.00	21.60	AV	L1	Pass
13.550000	40.60	10.80	50.00	9.40	AV	L1	Pass
13.560000	66.80	10.80	50.00	-16.80	AV	N	Wanted signal
13.620000	13.30	10.80	50.00	36.70	AV	N	Pass
13.635000	13.90	10.80	50.00	36.10	AV	L1	Pass
13.665000	7.50	10.80	50.00	42.50	AV	N	Pass
13.680000	17.50	10.80	50.00	32.50	AV	L1	Pass
13.695000	12.60	10.80	50.00	37.40	AV	N	Pass
13.705000	12.50	10.80	50.00	37.50	AV	L1	Pass
13.730000	12.10	10.80	50.00	37.90	AV	L1	Pass
13.770000	13.40	10.80	50.00	36.60	AV	L1	Pass

With dummy load:
With Netgear PoE switch supplied with 120Vac,60Hz

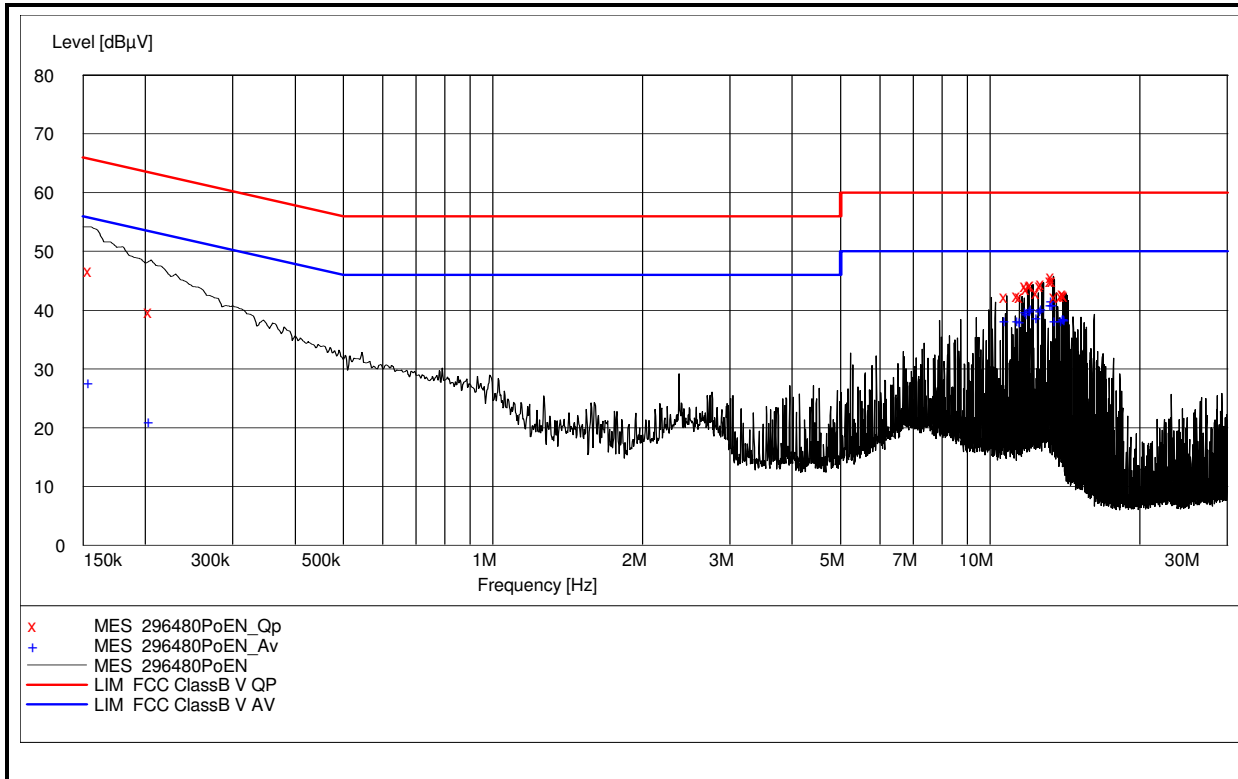

With QP detector:

Frequency [MHz]	Level [dBuV]	Af [dB]	Limit [dBuV]	Margin [dB]	Det	Position	Verdict [Pass/Fail]
0.155000	46.80	10.70	65.70	18.90	QP	N	Pass
0.205000	39.80	10.70	63.40	23.60	QP	L1	Pass
10.795000	42.40	10.70	60.00	17.60	QP	N	Pass
11.465000	42.50	10.70	60.00	17.50	QP	N	Pass
11.585000	42.30	10.70	60.00	17.70	QP	N	Pass
11.890000	44.10	10.70	60.00	15.90	QP	N	Pass
11.955000	43.70	10.70	60.00	16.30	QP	N	Pass
12.135000	44.10	10.70	60.00	15.90	QP	N	Pass
12.200000	44.40	10.70	60.00	15.60	QP	N	Pass
12.505000	43.00	10.70	60.00	17.00	QP	N	Pass
12.745000	44.30	10.70	60.00	15.70	QP	N	Pass
12.810000	44.60	10.70	60.00	15.40	QP	N	Pass
13.360000	45.10	10.80	60.00	14.90	QP	N	Pass
13.420000	45.80	10.80	60.00	14.20	QP	N	Pass
13.480000	45.10	10.80	60.00	14.90	QP	N	Pass
13.600000	42.40	10.80	60.00	17.60	QP	N	Pass
14.030000	42.50	10.80	60.00	17.50	QP	N	Pass
14.150000	42.80	10.80	60.00	17.20	QP	N	Pass
14.215000	42.70	10.80	60.00	17.30	QP	N	Pass
14.275000	42.60	10.80	60.00	17.40	QP	N	Pass

With AV detector:

Frequency [MHz]	Level [dBuV]	Af [dB]	Limit [dBuV]	Margin [dB]	Det	Position	Verdict [Pass/Fail]
0.155000	27.90	10.70	55.70	27.80	AV	N	Pass
0.205000	21.20	10.70	53.40	32.20	AV	L1	Pass
10.795000	38.40	10.70	50.00	11.60	AV	N	Pass
11.465000	38.50	10.70	50.00	11.50	AV	N	Pass
11.585000	38.30	10.70	50.00	11.70	AV	N	Pass
11.890000	40.00	10.70	50.00	10.00	AV	N	Pass
11.955000	39.70	10.70	50.00	10.30	AV	N	Pass
12.135000	40.10	10.70	50.00	9.90	AV	N	Pass
12.200000	40.50	10.70	50.00	9.50	AV	N	Pass
12.505000	39.00	10.70	50.00	11.00	AV	N	Pass
12.745000	40.20	10.70	50.00	9.80	AV	N	Pass
12.810000	40.60	10.70	50.00	9.40	AV	N	Pass
13.360000	41.20	10.80	50.00	8.80	AV	N	Pass
13.420000	41.80	10.80	50.00	8.20	AV	N	Pass
13.480000	41.10	10.80	50.00	8.90	AV	N	Pass
13.600000	38.40	10.80	50.00	11.60	AV	N	Pass
14.030000	38.50	10.80	50.00	11.50	AV	N	Pass
14.150000	38.80	10.80	50.00	11.20	AV	N	Pass
14.215000	38.70	10.80	50.00	11.30	AV	N	Pass
14.275000	38.60	10.80	50.00	11.40	AV	N	Pass

With Netgear PoE switch supplied with 120Vac,60Hz (Integral loop antenna)

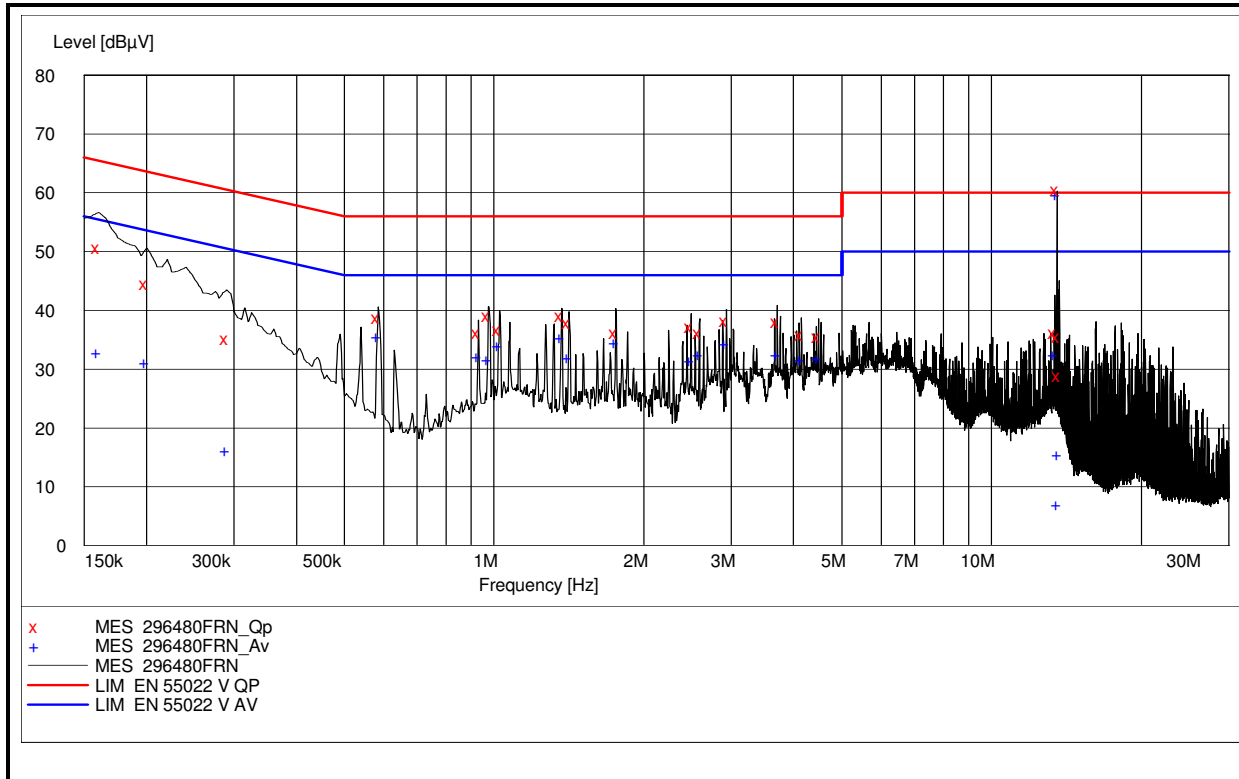

With QP detector:

Frequency [MHz]	Level [dBuV]	Af [dB]	Limit [dBuV]	Margin [dB]	Det	Position	Verdict [Pass/Fail]
0.160000	50.70	10.70	65.50	14.80	QP	N	Pass
0.200000	44.50	10.70	63.60	19.10	QP	L1	Pass
0.290000	35.30	10.50	60.50	25.20	QP	N	Pass
0.585000	38.90	10.20	56.00	17.10	QP	N	Pass
0.930000	36.20	10.30	56.00	19.80	QP	L1	Pass
0.975000	39.20	10.30	56.00	16.80	QP	L1	Pass
1.025000	36.70	10.40	56.00	19.30	QP	N	Pass
1.365000	39.10	10.40	56.00	16.90	QP	N	Pass
1.415000	38.00	10.40	56.00	18.00	QP	L1	Pass
1.755000	36.20	10.40	56.00	19.80	QP	L1	Pass
2.490000	37.30	10.40	56.00	18.70	QP	N	Pass
2.590000	36.30	10.40	56.00	19.70	QP	L1	Pass
2.930000	38.20	10.40	56.00	17.80	QP	L1	Pass
3.710000	38.10	10.40	56.00	17.90	QP	N	Pass
4.150000	35.90	10.50	56.00	20.10	QP	L1	Pass
4.490000	35.60	10.50	56.00	20.40	QP	N	Pass
13.420000	36.30	10.80	60.00	23.70	QP	N	Pass
13.560000	60.60	10.80	60.00	-0.60	QP	L1	Wanted signal
13.650000	35.60	10.80	60.00	24.40	QP	N	Pass
13.680000	28.90	10.80	60.00	31.10	QP	L1	Pass

With AV detector:

Frequency [MHz]	Level [dBuV]	Af [dB]	Limit [dBuV]	Margin [dB]	Det	Position	Verdict [Pass/Fail]
0.160000	32.90	10.70	55.50	22.60	AV	N	Pass
0.200000	31.40	10.70	53.60	22.20	AV	L1	Pass
0.290000	16.30	10.50	50.50	34.20	AV	N	Pass
0.585000	35.70	10.20	46.00	10.30	AV	N	Pass
0.930000	32.40	10.30	46.00	13.60	AV	L1	Pass
0.975000	31.80	10.30	46.00	14.20	AV	L1	Pass
1.025000	34.30	10.40	46.00	11.70	AV	N	Pass
1.365000	35.60	10.40	46.00	10.40	AV	N	Pass
1.415000	32.10	10.40	46.00	13.90	AV	L1	Pass
1.755000	34.70	10.40	46.00	11.30	AV	L1	Pass
2.490000	31.60	10.40	46.00	14.40	AV	N	Pass
2.590000	32.70	10.40	46.00	13.30	AV	L1	Pass
2.930000	34.60	10.40	46.00	11.40	AV	L1	Pass
3.710000	32.70	10.40	46.00	13.30	AV	N	Pass
4.150000	31.80	10.50	46.00	14.20	AV	L1	Pass
4.490000	32.00	10.50	46.00	14.00	AV	N	Pass
13.420000	32.70	10.80	50.00	17.30	AV	N	Pass
13.560000	59.90	10.80	50.00	-9.90	AV	L1	Wanted signal
13.650000	7.10	10.80	50.00	42.90	AV	N	Pass
13.680000	15.70	10.80	50.00	34.30	AV	L1	Pass

With dummy load:

With USB power via ASUS laptop. The ASUS lap top is supplied with 120Vac, 60Hz

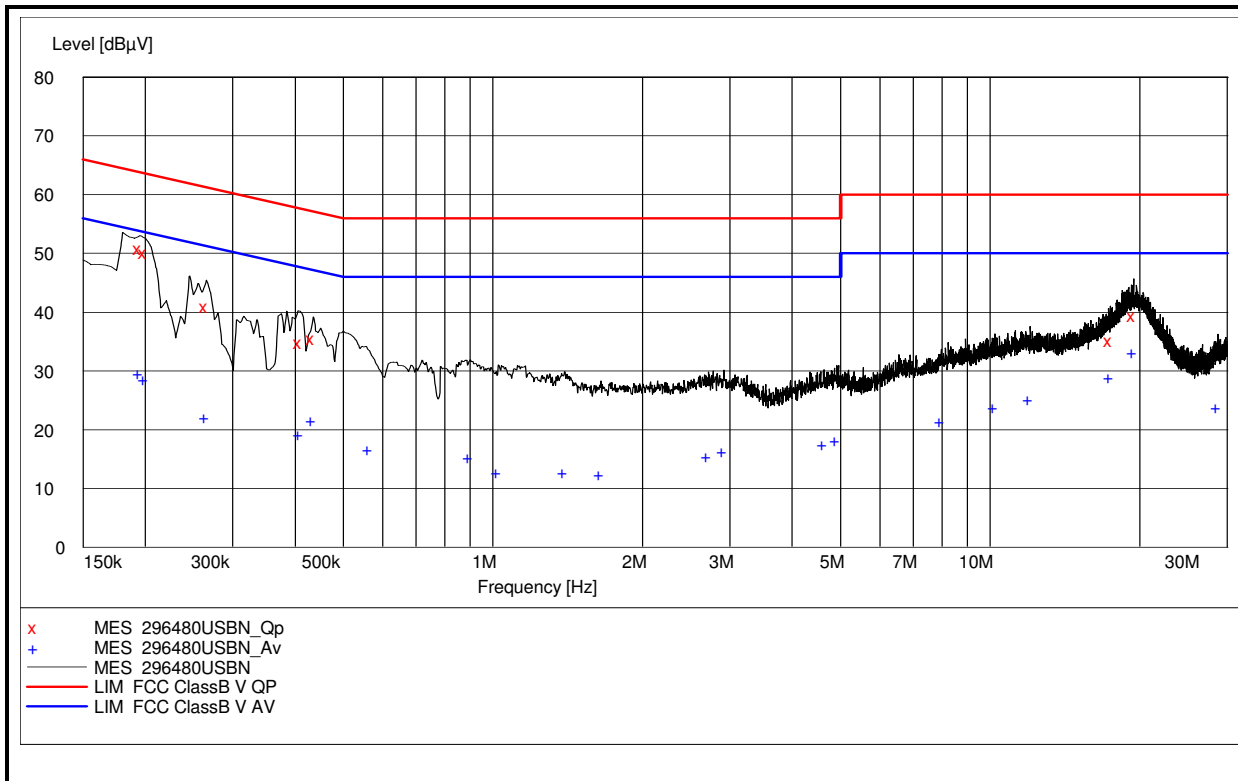

With QP detector:

Frequency [MHz]	Level [dBuV]	Af [dB]	Limit [dBuV]	Margin [dB]	Det	Position	Verdict [Pass/Fail]
0.195000	50.80	10.70	63.80	13.00	QP	N	Pass
0.200000	50.20	10.70	63.60	13.40	QP	N	Pass
0.265000	41.00	10.60	61.30	20.30	QP	N	Pass
0.410000	34.90	10.40	57.60	22.70	QP	N	Pass
0.435000	35.60	10.30	57.20	21.60	QP	N	Pass
17.445000	35.20	10.80	60.00	24.80	QP	L1	Pass
19.475000	39.40	10.80	60.00	20.60	QP	L1	Pass

With AV detector:

Frequency [MHz]	Level [dBuV]	Af [dB]	Limit [dBuV]	Margin [dB]	Det	Position	Verdict [Pass/Fail]
0.195000	29.80	10.70	53.80	24.00	AV	N	Pass
0.200000	28.70	10.70	53.60	24.90	AV	N	Pass
0.265000	22.30	10.60	51.30	29.00	AV	N	Pass
0.410000	19.40	10.40	47.60	28.20	AV	N	Pass
0.435000	21.70	10.30	47.20	25.50	AV	N	Pass
0.565000	16.80	10.20	46.00	29.20	AV	N	Pass
0.900000	15.40	10.30	46.00	30.60	AV	N	Pass
1.025000	12.80	10.40	46.00	33.20	AV	N	Pass
1.395000	12.80	10.40	46.00	33.20	AV	N	Pass
1.650000	12.60	10.40	46.00	33.40	AV	L1	Pass
2.715000	15.70	10.40	46.00	30.30	AV	N	Pass
2.915000	16.40	10.40	46.00	29.60	AV	N	Pass
4.635000	17.70	10.50	46.00	28.30	AV	N	Pass
4.925000	18.40	10.50	46.00	27.60	AV	N	Pass
7.975000	21.50	10.60	50.00	28.50	AV	L1	Pass
10.225000	24.00	10.70	50.00	26.00	AV	L1	Pass
12.030000	25.40	10.70	50.00	24.60	AV	L1	Pass
17.445000	29.10	10.80	50.00	20.90	AV	L1	Pass
19.475000	33.30	10.80	50.00	16.70	AV	L1	Pass
28.785000	24.00	11.10	50.00	26.00	AV	N	Pass

With integral loop antenna:

With USB power via ASUS laptop. The ASUS lap top is supplied with 120Vac, 60Hz

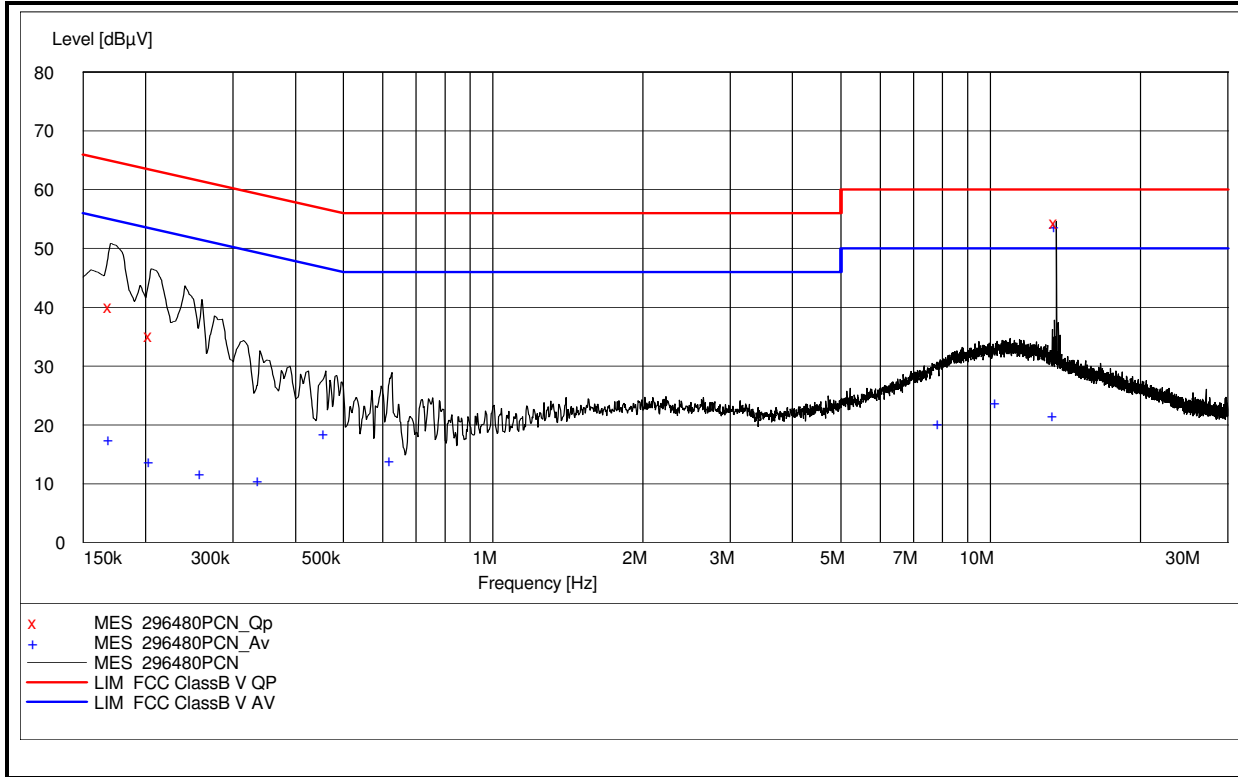

With QP detector:

Frequency [MHz]	Level [dBuV]	Af [dB]	Limit [dBuV]	Margin [dB]	Det	Position	Verdict [Pass/Fail]
0.170000	40.20	10.70	65.00	24.80	QP	N	Pass
0.205000	35.20	10.70	63.40	28.20	QP	N	Pass
13.560000	54.50	10.80	60.00	5.50	QP	N	Wanted signal

With AV detector:

Frequency [MHz]	Level [dBuV]	Af [dB]	Limit [dBuV]	Margin [dB]	Det	Position	Verdict [Pass/Fail]
0.170000	17.70	10.70	55.00	37.30	AV	N	Pass
0.205000	14.00	10.70	53.40	39.40	AV	N	Pass
0.260000	11.90	10.60	51.40	39.50	AV	L1	Pass
0.340000	10.80	10.50	49.20	38.40	AV	N	Pass
0.460000	18.70	10.30	46.70	28.00	AV	L1	Pass
0.625000	14.10	10.20	46.00	31.90	AV	L1	Pass
7.910000	20.40	10.60	50.00	29.60	AV	N	Pass
10.305000	24.10	10.70	50.00	25.90	AV	N	Pass
13.440000	21.80	10.80	50.00	28.20	AV	L1	Pass
13.560000	53.90	10.80	50.00	-3.90	AV	N	Wanted signal

3.3 Peak power output

Para. No.: 15.225 (a) / A2.9

Test Performed By: G.Suhandhakumar	Date of Test: 23-Nov-2015
------------------------------------	---------------------------

Test Results: Complies

Measurement data:

Maximum field strength

RF channel 13.56MHz	Measured PK value (dB μ V/m) @ 10m	Distance Correction factor dB	Converted Limit @10m (dB μ V/m)
Card waiting	46.45	-19.5	103.5
Card Reading	43.92	-19.5	103.5

The limit line given in the graph is corrected to 10m distance.

Radiated measurements are performed at 10 m distance.

- Detachable antenna? Yes No
 If detachable, is the antenna connector non-standard? Yes No
 Integral loop antenna

New batteries were used.

Requirements:

The maximum field strength within band 13.553 – 13.567MHz at 30 meters shall be ≤ 84.0 dB μ V/m (at 10 meters ≤ 103.5 dB μ V/m)

- (b) 334 microvolts/m (50.5 dB μ V/m) at 30 m, within the bands 13.410-13.553 MHz and 13.567-13.710 MHz. (at 10 meters ≤ 70.0 dB μ V/m)
- (c) 106 microvolts/m (40.5 dB μ V/m) at 30 m, within the bands 13.110-13.410 MHz and 13.710-14.010 MHz. (at 10 meters ≤ 60.0 dB μ V/m)



Att 0 dB AUTO RBW 9 kHz
 MT 2 s
 PREAMP ON

FREQUENCY	13.5600000	MHz
LEVEL PK+	46.45	dB μ V/m
QPK	37.18	dB μ V/m
AV	21.05	dB μ V/m

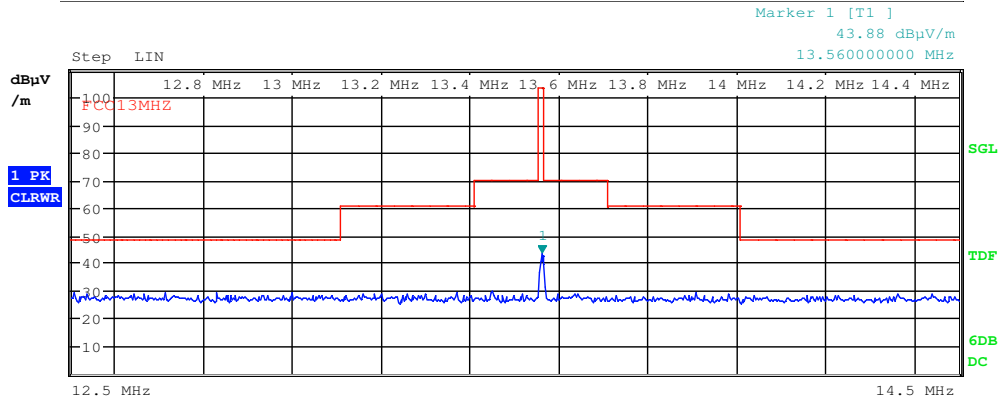
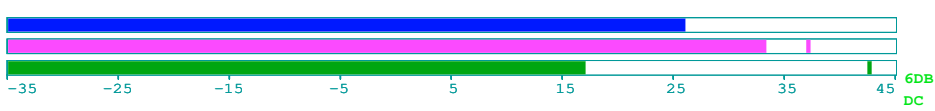

Date: 14.NOV.2015 19:45:14

Card Waiting: Field strength at longitudinal polarization – 13.56MHz



Att 0 dB AUTO RBW 9 kHz
 MT 100 ms
 PREAMP ON

FREQUENCY	13.5600000	MHz
LEVEL PK+	43.92	dB μ V/m
QPK	42.93	dB μ V/m
AV	42.69	dB μ V/m

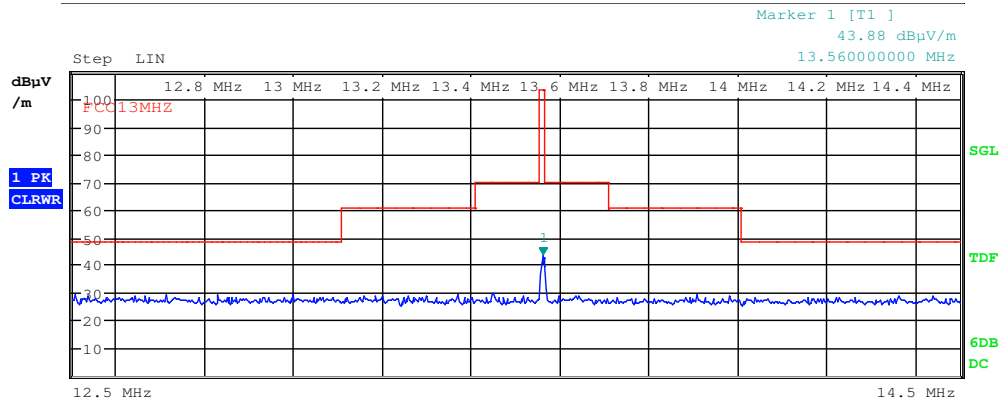
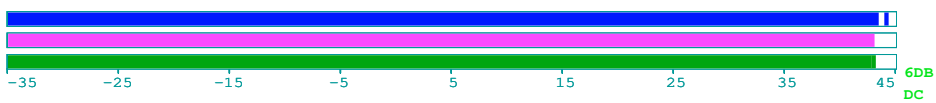

Date: 14.NOV.2015 19:44:10

Card reading: Field strength at longitudinal polarization – 13.56MHz

3.4 Spurious emissions (radiated)

Para. No.: 15.209 / 15.225 (b,c,d) / A2.6 / 4.9

Test Performed By: G.Suhandhakumar	Date of Test: 14-Nov-2015
------------------------------------	---------------------------

Test Results: Complies

Measurement Data:

Radiated Emissions with loop antenna, 9kHz – 30MHz

measured at a distance of 10m.

Measured with Peak Detector:

Frequency	Dist. corr. factor	Measured Field strength, Peak @ 10m	Duty cycle corr. factor	Calculated Field strength, Average @ 300m	Limit @ 300m	Margin
kHz	dB	dB μ V/m	dB	dB μ V/m	dB μ V/m	dB
/	59.1	None detected	-1.33	/	36.8	/

The limit line given in the graph is corrected to 10m distance.

The above detected frequencies lies within the band 9 – 90kHz . The emission limit in this band is based on average detector.

The maximum is observed in longitudinal polarization

Antenna factor, amplifier gain and cable loss are included in spectrum analyzer “Transducer factor”.

Duty Cycle Correction Factor Calculation:

RF duty cycle: Calculation according to RF burst Para 15.35 (c)

Measured in card waiting mode with 86% duty cycle and in card reading mode duty cycle is 75%.

Card reading:

Measured Pulse train period= 8 ms, burst ON duration : 6 ms

DC Correction factor = $-20 \times \log((6\text{ms}) / 8\text{ms}) = -2.49 \text{ dB}$

Card waiting:

Measured Pulse train period= 131.37 ms, First burst ON duration : 5.9 ms , 2nd burst ON time : 10.91ms, 3rd ON time: 12.9ms, 4th ON time :83.04ms

DC Correction factor = $-20 \times \log((112.75\text{ms}) / 131.37\text{ms}) = -1.33 \text{ dB}$

Maximum Duty Cycle Correction Factor according to Para 15.35 (b): 20 dB

Requirement:

(d) The field strength of any emissions appearing outside of the 13.110 – 14.010 MHz band shall not exceed the general radiated emission limits in §15.209.

Radiated emissions 9kHz – 30 MHz.

Detector: Peak

Measuring distance 10 m. The limit is corrected to 10m distance.

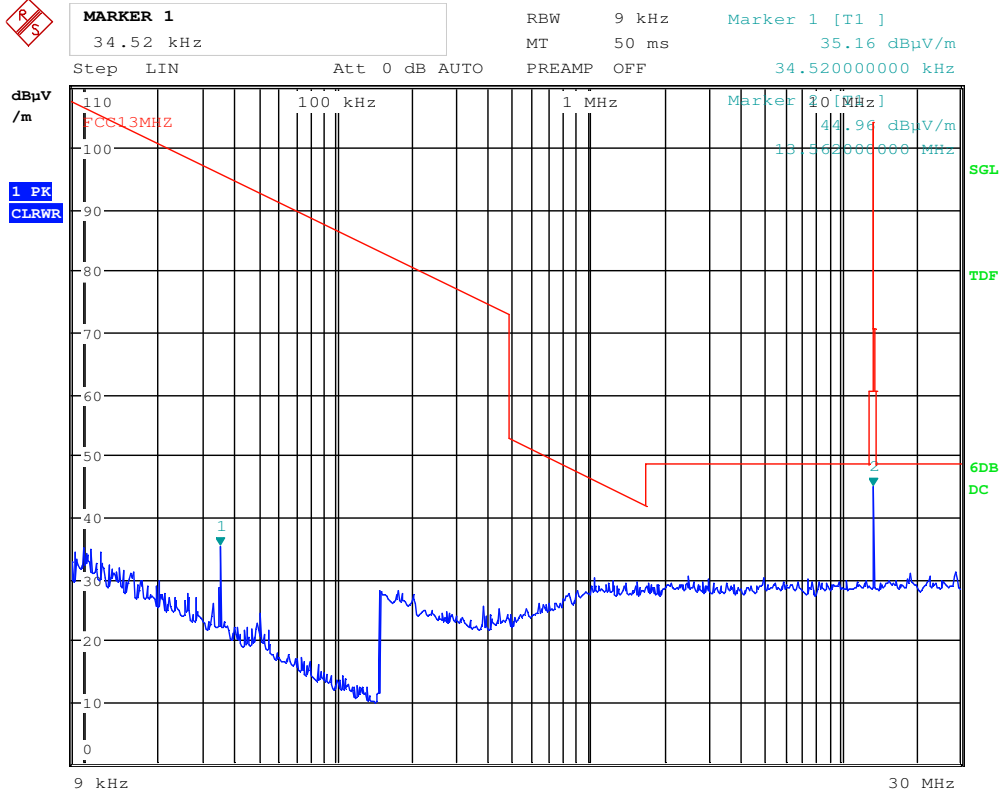

Date: 14.NOV.2015 19:39:39

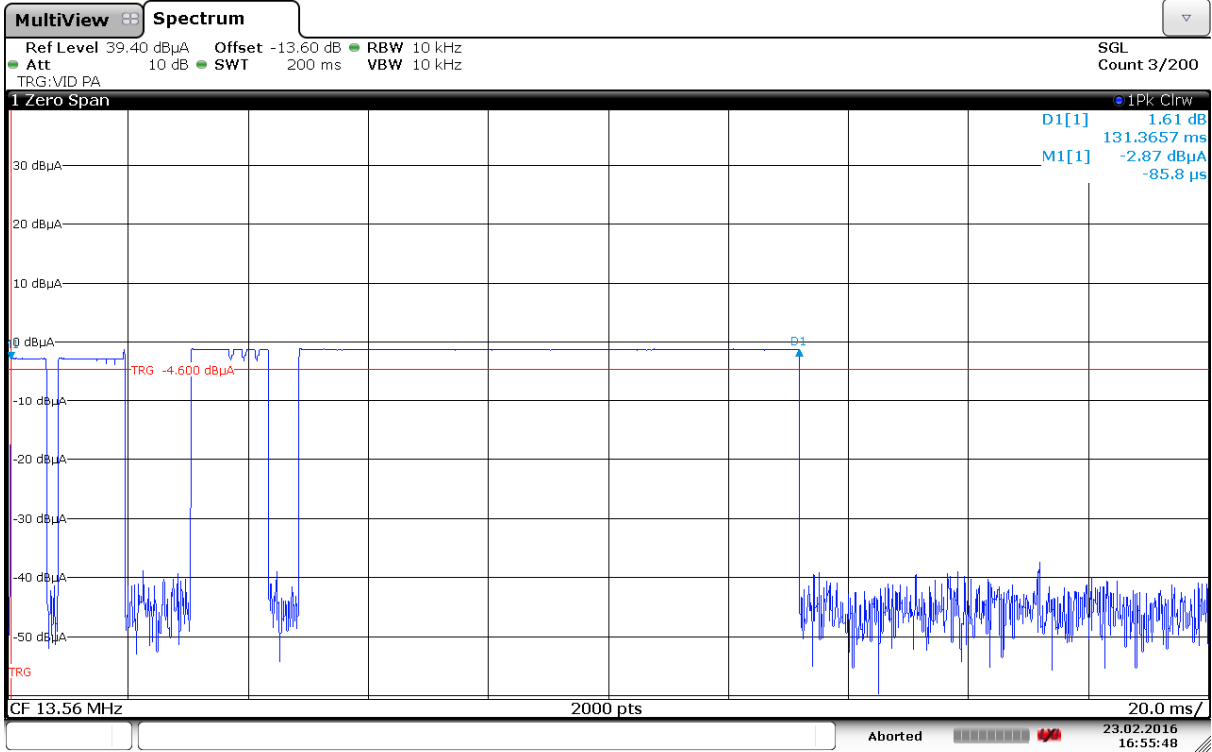

Date: 23.FEB.2016 16:55:48

Pulse train period during card waiting mode

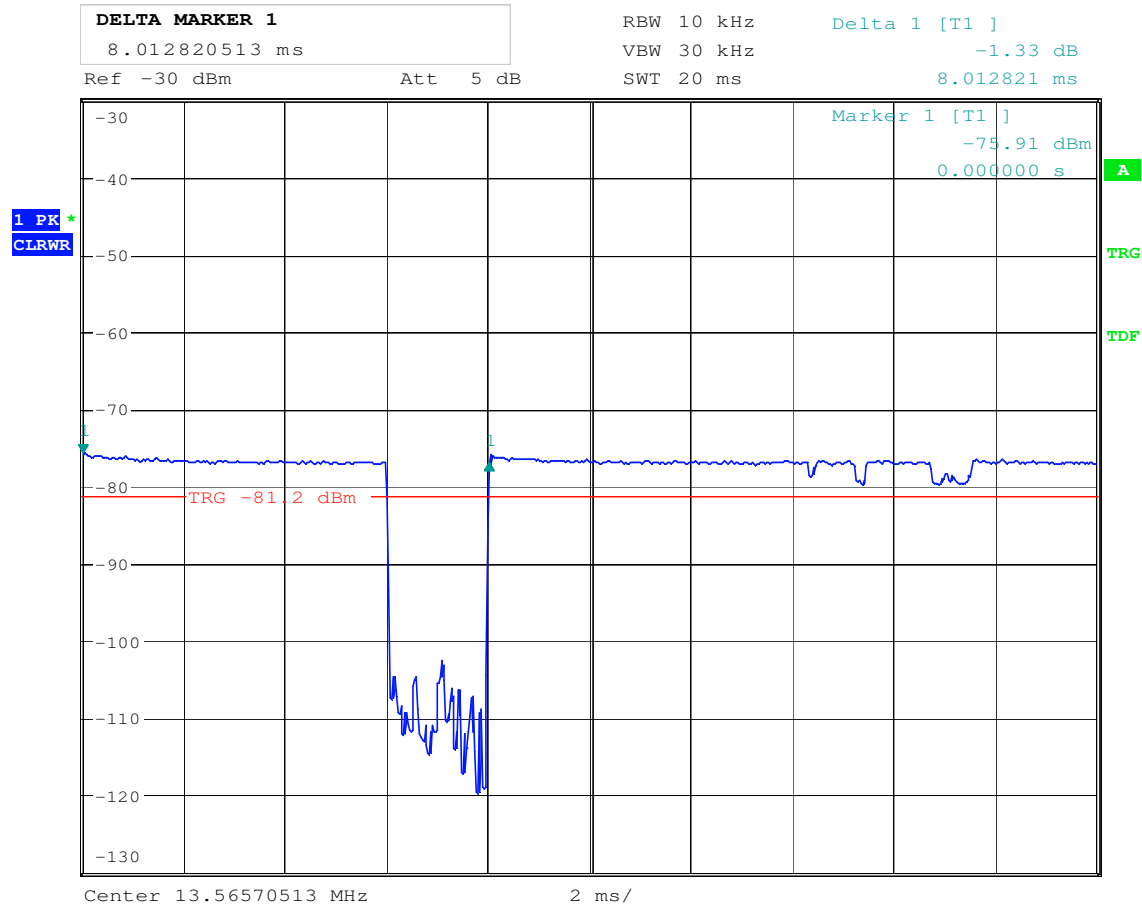

Date: 9.NOV.2015 12:27:04
 Pulse train period during card reading mode

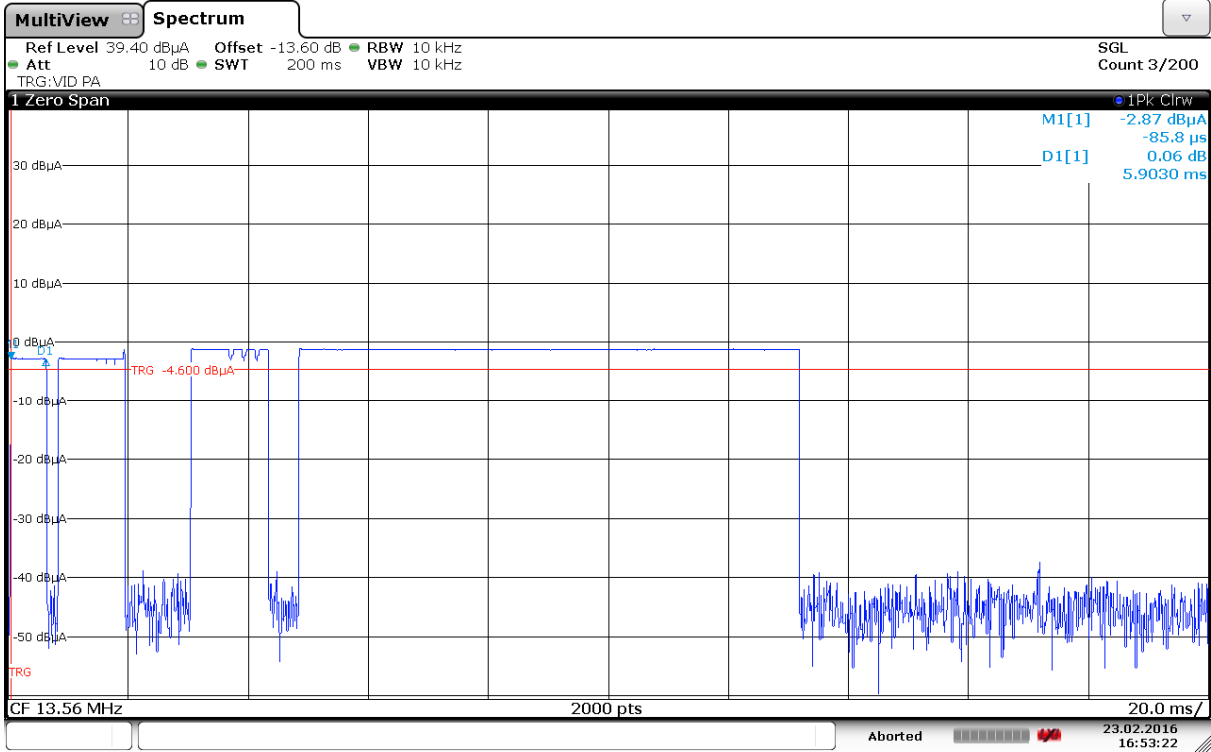

Date: 23.FEB.2016 16:53:22

First burst ON time during card waiting mode

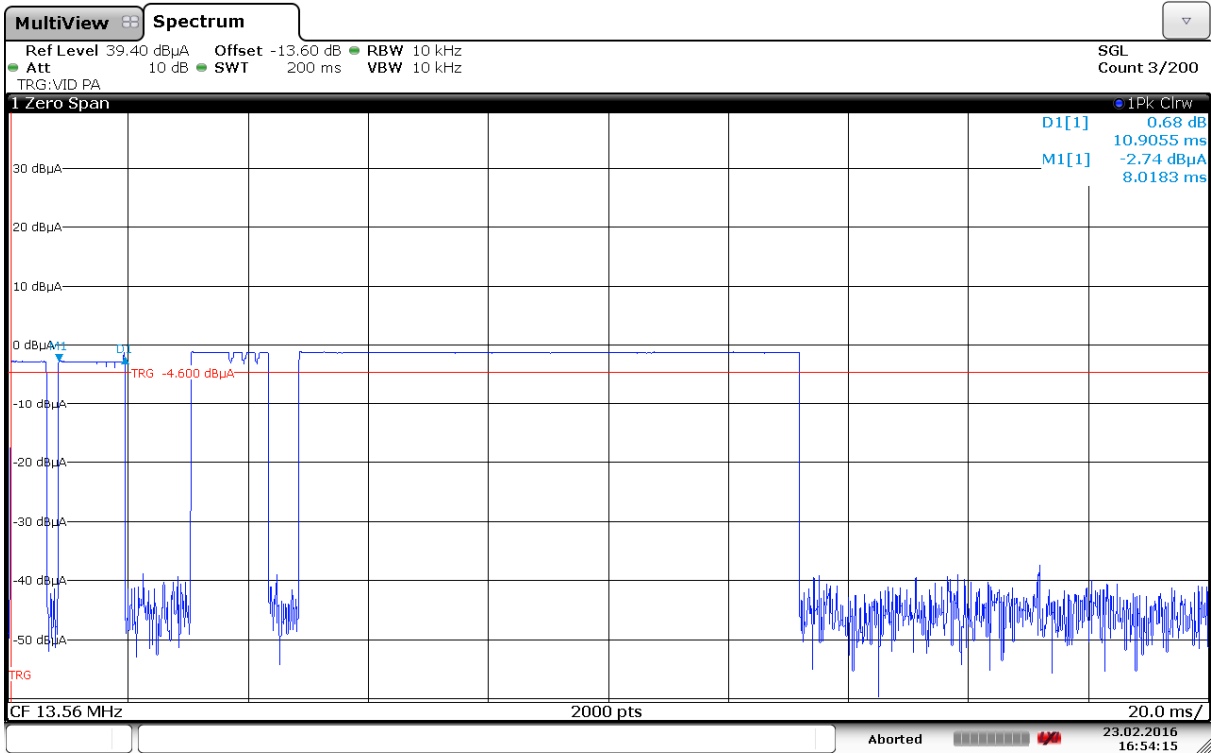

Date: 23.FEB.2016 16:54:15

Second burst ON time card waiting mode

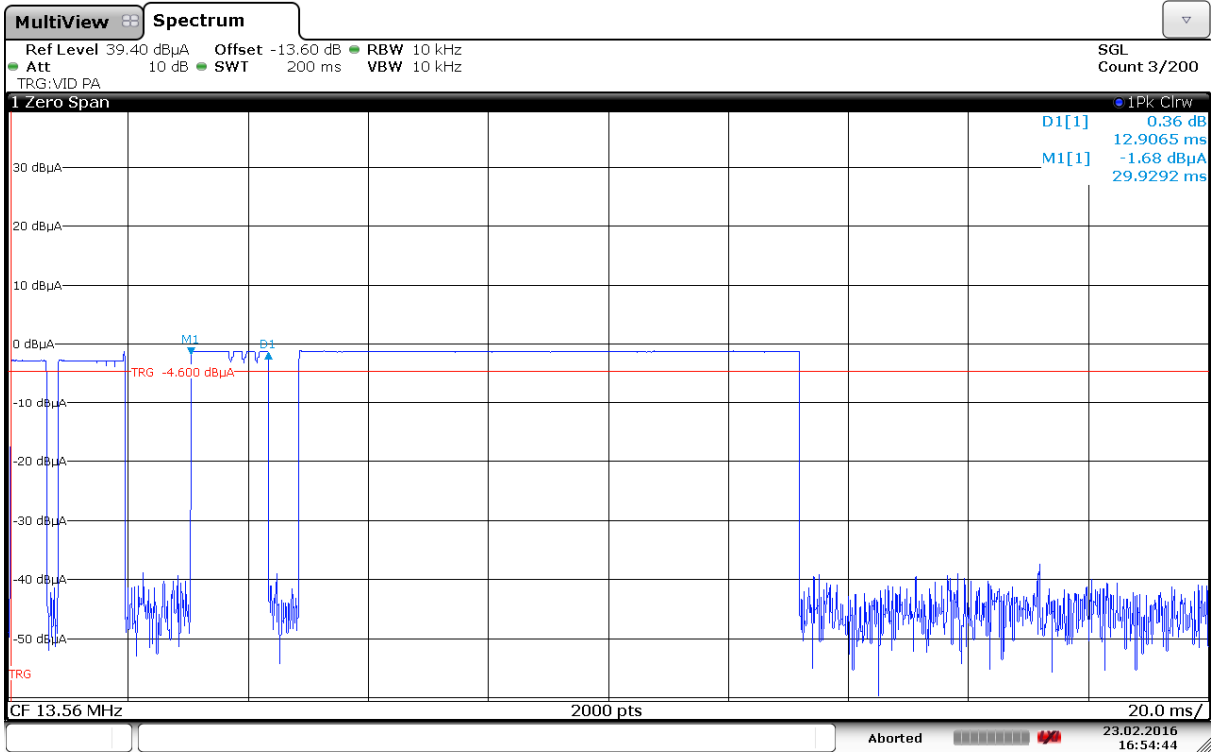

Date: 23.FEB.2016 16:54:44

Third burst ON time during card waiting mode

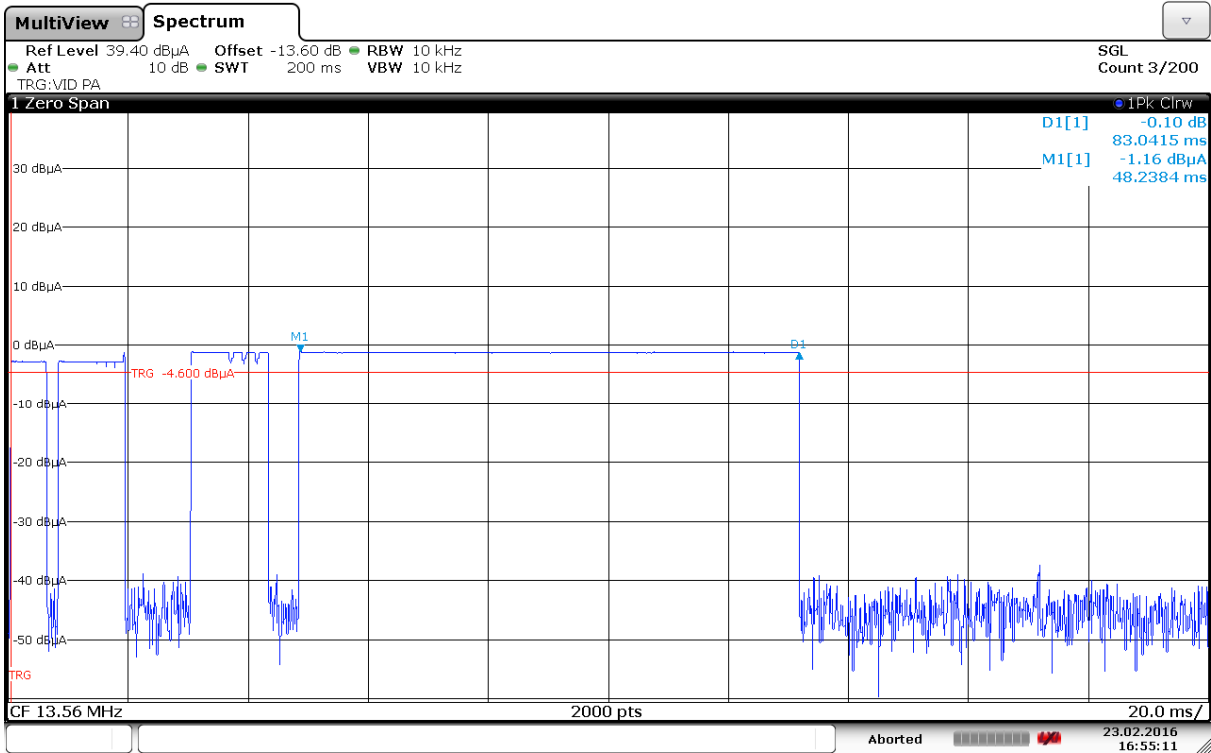

Date: 23.FEB.2016 16:55:12

Fourth burst ON time during card waiting mode

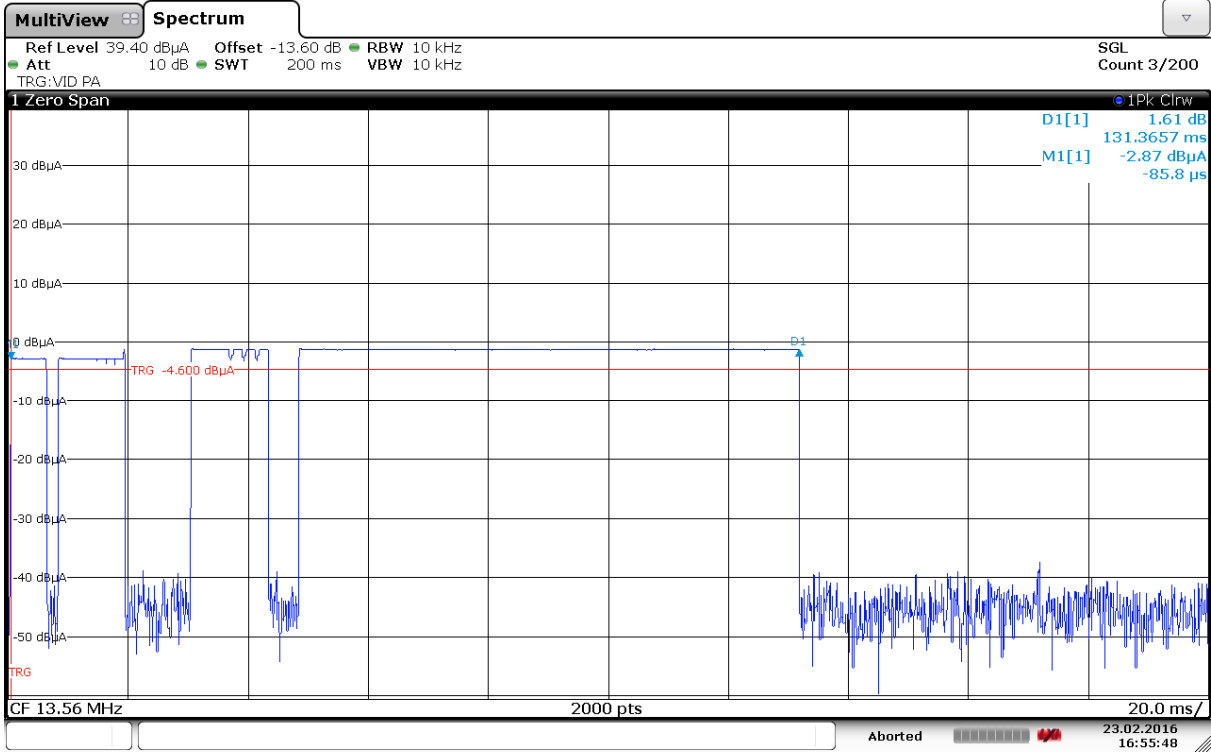

Date: 23.FEB.2016 16:55:48

Total length of puls period during card waiting

Radiated emissions 30 – 1000 MHz.

Detector: QP

Measuring distance 3 m.

The graph shows peak scan and highest values.

The worst case spurious emissions are obtained in card waiting mode.

FCC Pt15 Class C 30-1000 MHz 3m

Full Spectrum

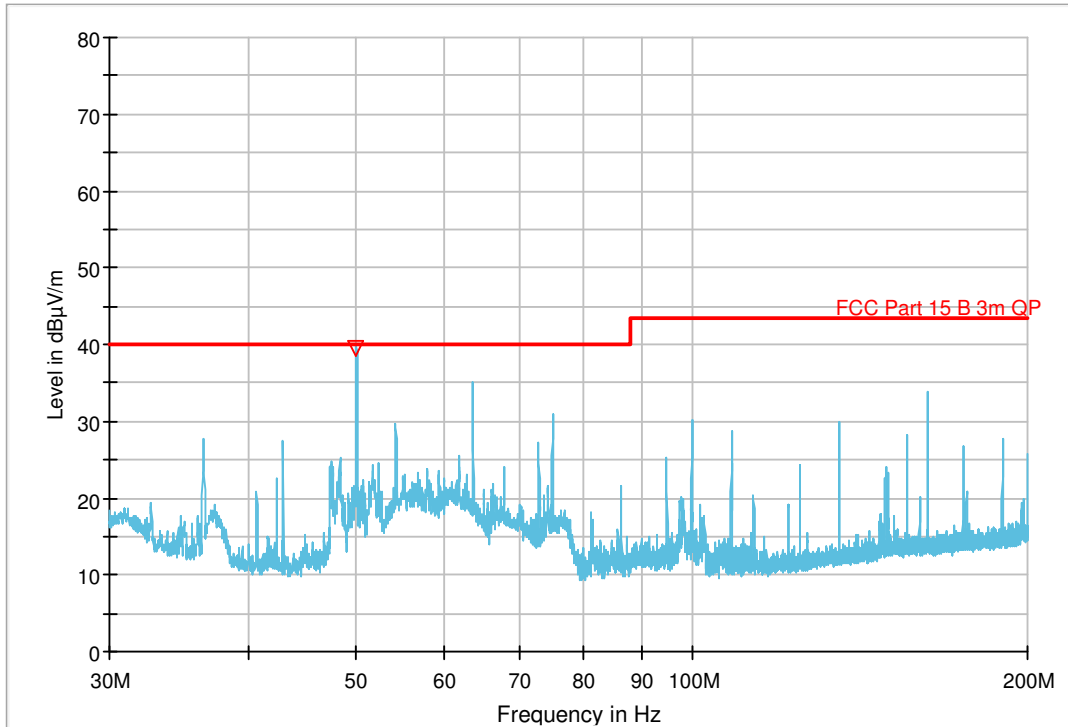

30 - 200MHz with AC/DC adapter - card waiting

Full Spectrum

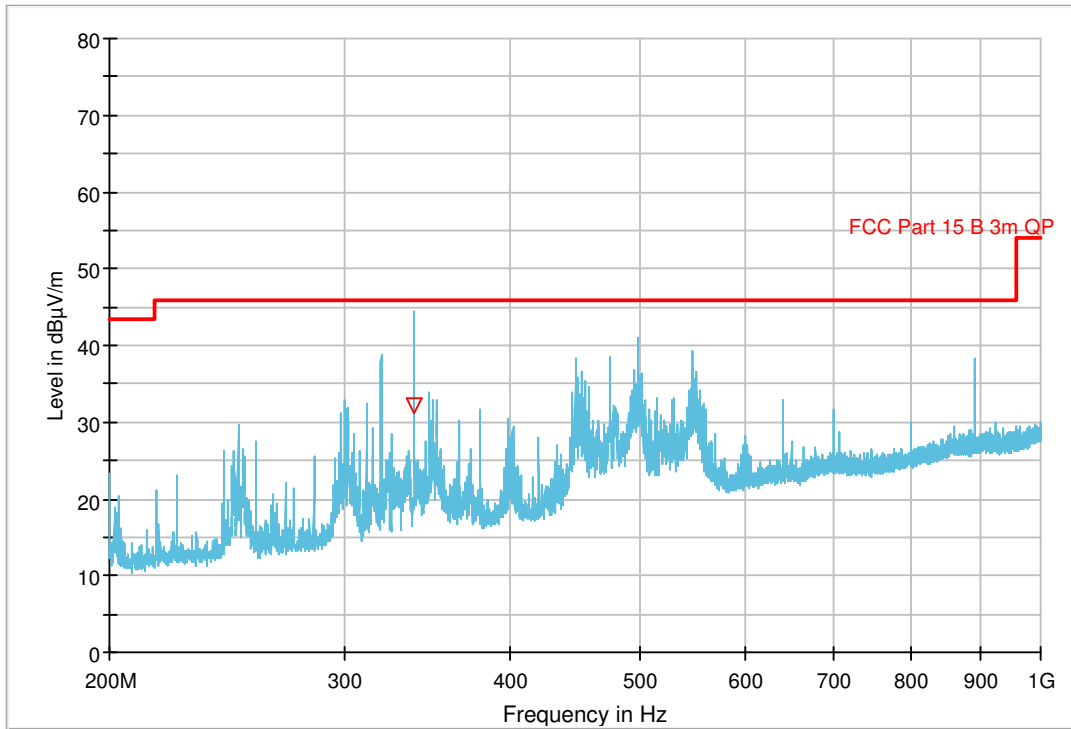

200 - 1000MHz with AC/DC adapter – card waiting

AC/DC adapter – card waiting

Frequency (MHz)	QuasiPeak (dBµV/m)	Limit (dBµV/m)	Margin (dB)	Meas. Time (ms)	Bandwidth (kHz)	Height (cm)	Pol	Azimuth (deg)	Corr. (dB)
50.001000	39.63	40.00	0.37	1000.0	120.000	100.0	V	220.0	-14.9
338.920200	32.08	46.00	13.92	1000.0	120.000	113.0	H	77.0	-8.0

Full Spectrum

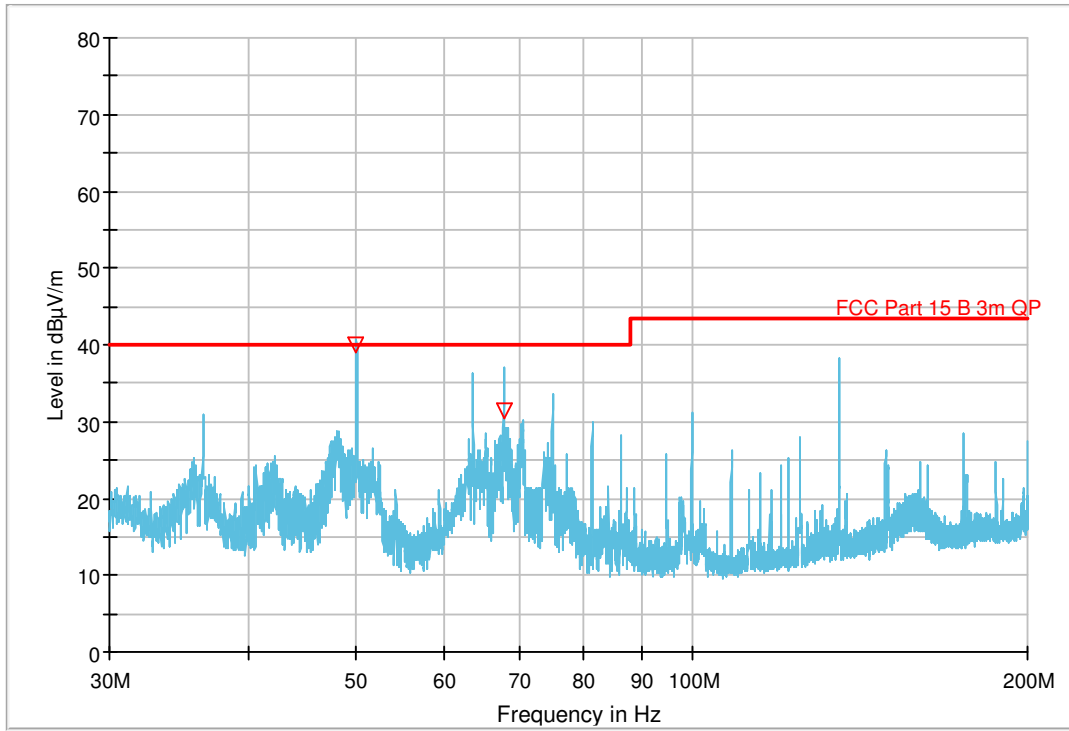

30 - 200MHz with PoE – card waiting

Full Spectrum

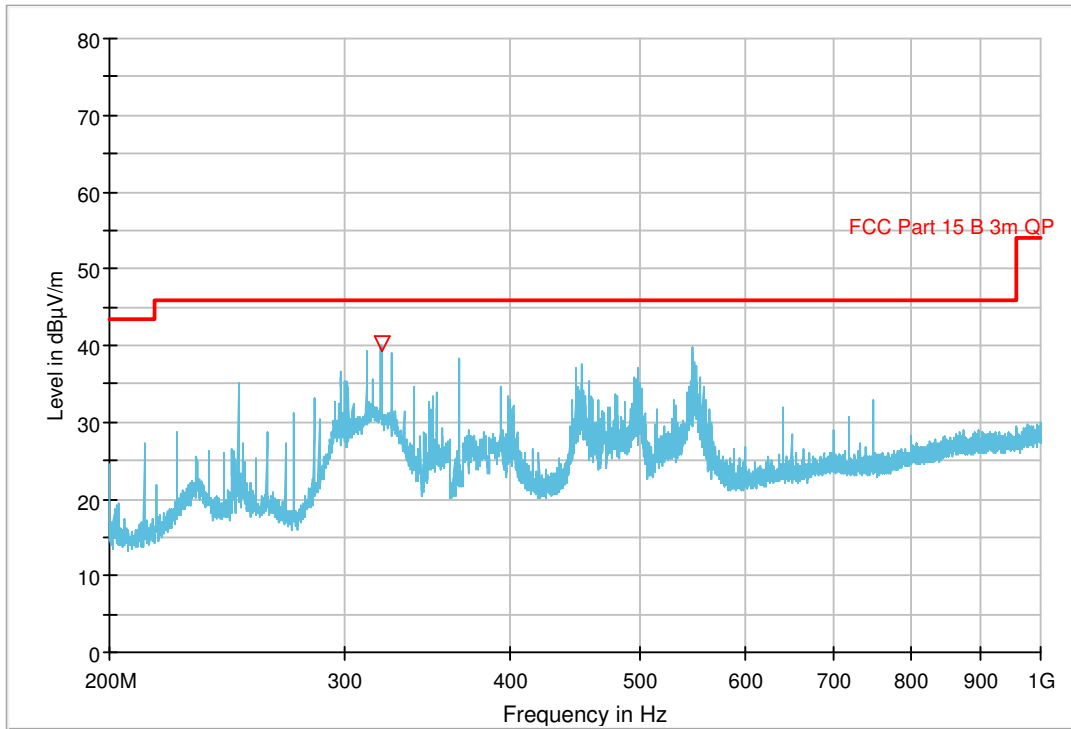

200 - 1000MHz with PoE – card waiting

PoE – card waiting

Frequency (MHz)	QuasiPeak (dBµV/m)	Limit (dBµV/m)	Margin (dB)	Meas. Time (ms)	Bandwidth (kHz)	Height (cm)	Pol	Azimuth (deg)	Corr. (dB)
50.001050	39.92	40.00	0.08	1000.0	120.000	100.0	V	207.0	-14.9
67.812450	31.39	40.00	8.61	1000.0	120.000	182.0	V	220.0	-15.5
320.010150	40.32	46.00	5.68	1000.0	120.000	112.0	H	108.0	-8.6

Full Spectrum

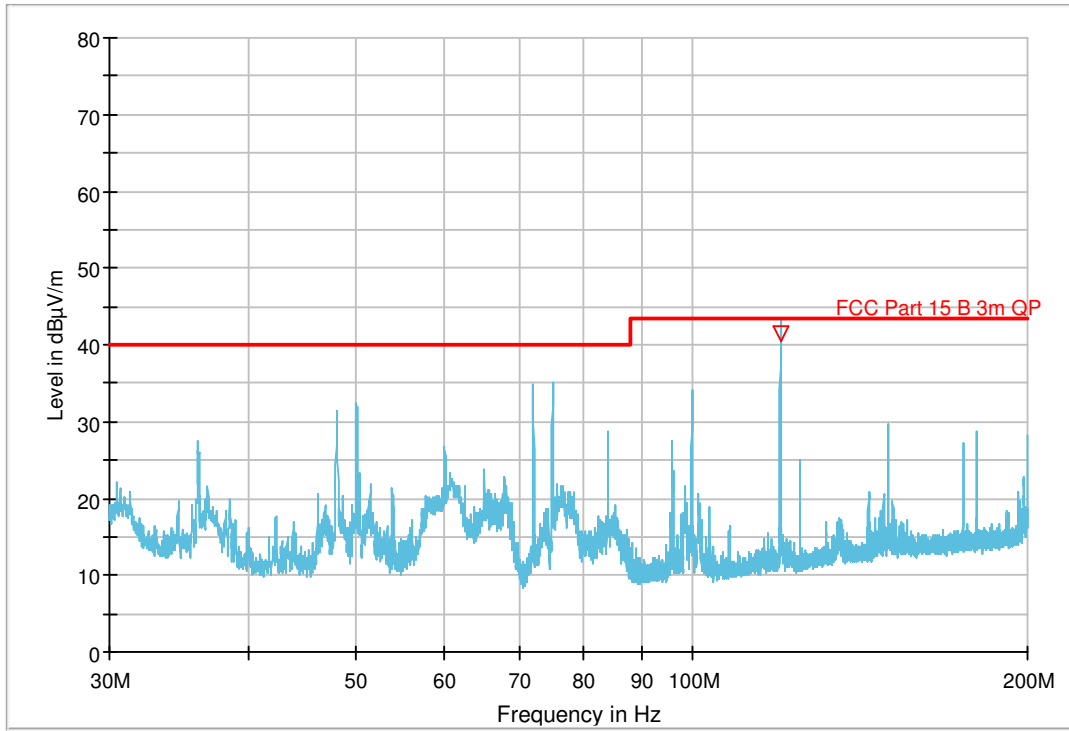

30 - 200MHz with USB – card waiting

Full Spectrum

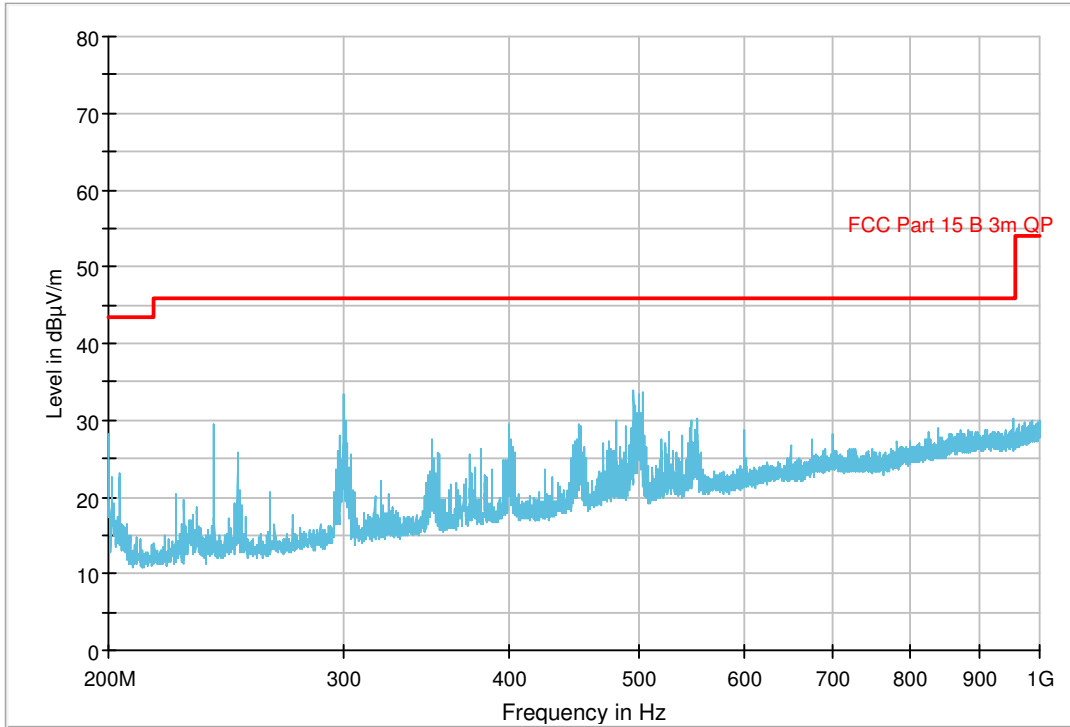

200 - 1000MHz with USB - card waiting

Frequency (MHz)	QuasiPeak (dBµV/m)	Limit (dBµV/m)	Margin (dB)	Meas. Time (ms)	Bandwidth (kHz)	Height (cm)	Pol	Azimuth (deg)	Corr. (dB)
120.022900	41.57	43.50	1.93	1000.0	120.000	100.0	V	188.0	-12.6

3.5 Transmitter Frequency Stability

Para. No.: 15.225(e)/A2.6

Test Performed By: G.Suhandhakumar	Date of Test: 14-Nov-2015
------------------------------------	---------------------------

Measurement Data:

Primary supply voltage: 120Vac/60Hz

Temperature	Given Frequency (MHz)	Measured value (MHz)	Deviation (%)
+50 ° C	13.56	13.56008	0.00059
+40 ° C	13.56	13.56012	-0.00088
+30 ° C	13.56	13.56012	-0.00088
+20 ° C	13.56	13.56016	-0.00118
+10 ° C	13.56	13.56012	-0.00088
+0 ° C	13.56	13.56014	-0.00103
-10 ° C	13.56	13.56016	-0.00118
-20 ° C	13.56	13.56008	-0.00059

At nominal temperature (+20 ° C) the frequency stability was checked that power variations between 85% and 115% did not have any influence on the frequency stability.

Requirement:

(e) The frequency tolerance of the carrier signal shall be maintained within $\pm 0.01\%$ of the operating frequency over a temperature variation of -20 degrees to $+ 50$ degrees C at normal supply voltage, and for a variation in the primary supply voltage from 85% to 115% of the rated supply voltage at a temperature of 20 degrees C. For battery operated equipment, the equipment tests shall be performed using a new battery.

4 Measurement Uncertainty

Measurement Uncertainty Values		
Test Item		Uncertainty
Output Power		±0.5 dB
Power Spectral Density		±0.5 dB
Out of Band Emissions, Conducted	< 3.6 GHz	±0.6 dB
	> 3.6 GHz	±0.9 dB
Spurious Emissions, Radiated	< 1 GHz	±2.5 dB
	> 1 GHz	±2.2 dB
Emission Bandwidth		±4 %
Power Line Conducted Emissions		+2.9 / -4.1 dB
Spectrum Mask Measurements	Frequency	±5 %
	Amplitude	±1.0 dB
Frequency Error		±0.6 ppm
Temperature Uncertainty		±1 °C

All uncertainty values are expanded standard uncertainty to give a confidence level of 95%, based on coverage factor k=2

5 LIST OF TEST EQUIPMENT

To facilitate inclusion on each page of the test equipment used for related tests, each item of test equipment and ancillaries are identified (numbered) by the Test Laboratory.

No.	Model number	Description	Manufacturer	Ref. no.	Cal. date	Cal. Due
1.	ESU40	EMI Receiver	Rohde & Schwarz	LR1639	2015.11	2016.11
2.	6810.17A	Attenuator	Suhner	LR 1137	2015.03.26	2017.03.26
3.	87V	Multimeter, Digital	Fluke	LR 1597	2015.10	2016.10
4.	HL223	Antenna log.per	Rohde & Schwarz	LR 1261	2013.12.05	2016.12.05
5.	HK116	Antenna biconic	Rohde & Schwarz	LR 1260	2013.12.05	2016.12.05
6.	LNA6900	Amplifier, low noise	Teseq	LR1593	2015.09	2016.09
7.	FSW	Spectrum analyser	R & S	LR 1551	2015.04	2017.04
8.	VC4060	Climatic chamber Temp	Vøtsch	LR 1435	2015.03.16	2016.03.16
9.	A 10-B	Rubidium	Quartzlock	LR 1386	2014.02	2016.02
10.	FA210A1010 003030	Microwave cable	Rosenberger	LR1566	Cal b4 use	
11.	3115	Antenna horn	EMCO	LR 1226	2013.10	2018.10
12.	ESH3-Z5	Two-Line V-Network	Rohde & Schwarz	N3403	2015.07.07	2017.07.07
13.	ESH3-Z2	Pulse Limiter	Rohde & Schwarz	N3932	2015.03.31	2017.03.31
14.	6812B	AC Power Source	Agilent	LR1515	2015.12.02	2017.12.02
15.	HFH2-Z2	Active Loop Antenna	Rohde & Schwarz	LR 1660	2014.10	2016.10
16.	ESHS10	EMI Receiver	Rohde & Schwarz	N3528	2015.08.14	2016.08.11
17.	017	Power Supply	Oltronix	B300	Cal b4 use	
18.	HFH2-Z4	Antenna Inductive Probe	R & S	LR 1100	Cal b4 use	

6 BLOCK DIAGRAM

6.1 System set up for radiated measurements

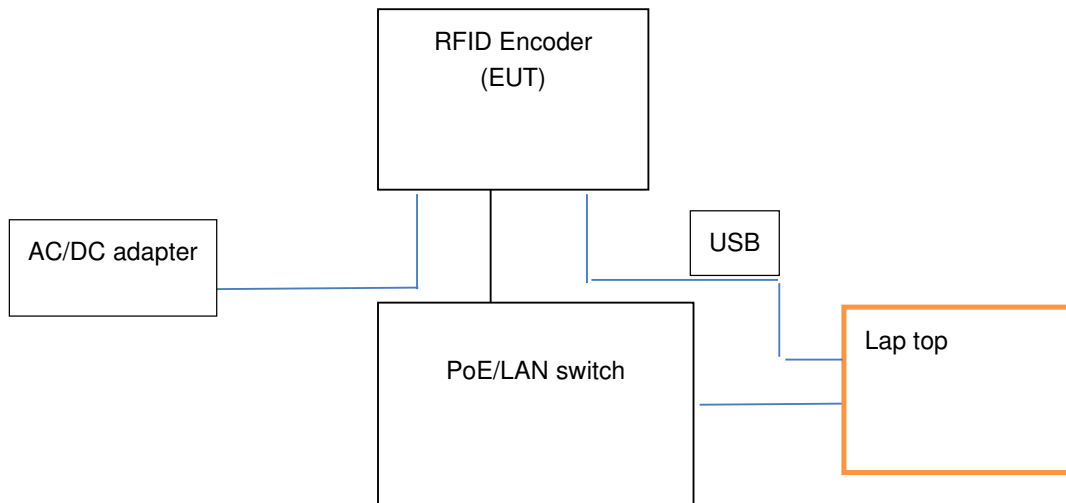

Test equipment: 1,3,4,5,6

6.2 Test Site Radiated Emission

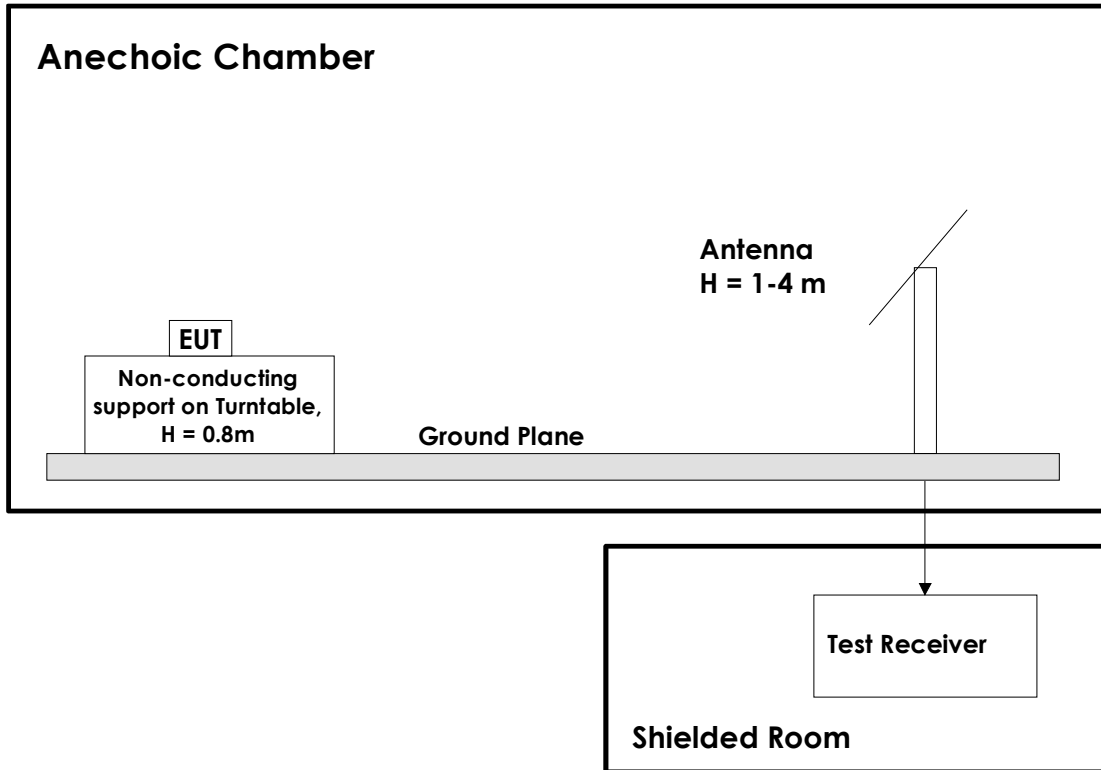

Revision history

Version	Date	Comment	Sign
0	2016.03.18	Version for TCB review	GNS
1	2016.05.12	Power line conducted emission with dummy load , frequency stability with $\pm 15\%$ on AC mains and updated instrument list included	GNS
2	2016.06.27	Exposure statement deleted. Test method corrected to ANSI C63.10-2013. Loop Antenna added to instrument list.	FS