

XCSR

Contactless RFID Safety Switches User Manual

(Original Document)

03/2017

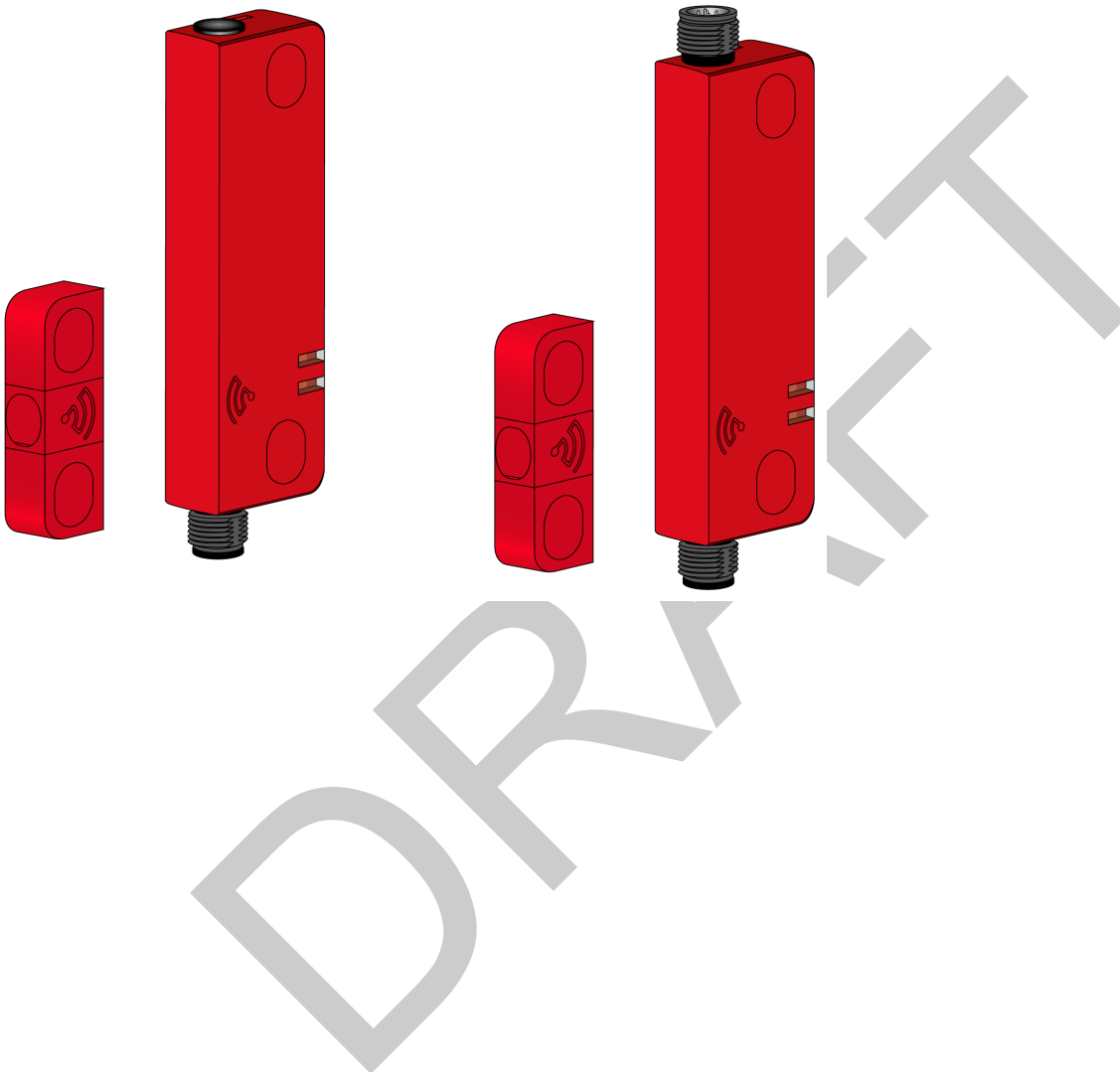

The information provided in this documentation contains general descriptions and/or technical characteristics of the performance of the products contained herein. This documentation is not intended as a substitute for and is not to be used for determining suitability or reliability of these products for specific user applications. It is the duty of any such user or integrator to perform the appropriate and complete risk analysis, evaluation and testing of the products with respect to the relevant specific application or use thereof. Neither Schneider Electric nor any of its affiliates or subsidiaries shall be responsible or liable for misuse of the information contained herein. If you have any suggestions for improvements or amendments or have found errors in this publication, please notify us.

No part of this document may be reproduced in any form or by any means, electronic or mechanical, including photocopying, without express written permission of Schneider Electric.

All pertinent state, regional, and local safety regulations must be observed when installing and using this product. For reasons of safety and to help ensure compliance with documented system data, only the manufacturer should perform repairs to components.

When devices are used for applications with technical safety requirements, the relevant instructions must be followed.

Failure to use Schneider Electric software or approved software with our hardware products may result in injury, harm, or improper operating results.

Failure to observe this information can result in injury or equipment damage.

© 2017 Schneider Electric. All Rights Reserved.

DRAFT

Table of Contents



	Safety Information	5
	About the Book	7
Part I	General	9
Chapter 1	Safety Requirements	11
	Safety Requirements	11
Chapter 2	Product Description	13
2.1	General Information	14
	XCSR RFID Safety Switch General Description	15
	How a XCSR RFID Safety Switch Works?	16
	Operating Zones ($S_{ao} - S_{ar}$)	17
	Definition of Characteristic Times	18
	System Response Time (Process Safety Time)	19
	Risk Assessment	20
2.2	XCSR RFID Safety Switch Functions	22
	Operating Modes	23
	External Device Monitoring (EDM) or Machine Primary Control Element (MPCE) Monitoring	25
	Operating and Output States, LED Meaning	26
	XCSR Standalone Models	28
	XCSR Series Connection (Daisy-Chain)	30
	XCSR Single Models	33
	Pairing Modes	35
2.3	System Components	37
	System Components Identification	38
	XCSR Features	39
Part II	Installation, Wiring, and Startup	41
Chapter 3	Installation	43
	Parts List	44
	Mounting the XCSR RFID Safety Switch	45
Chapter 4	Wiring	51
	Electrical Connections	52
	Connection Schematics	56
Part III	Technical Characteristics	63
Chapter 5	Technical Characteristics	65
	XCSR RFID Safety Switch Specifications	66
	Safety Related Data	69
	Dimensions	70
	Accessories	73
Part IV	XCSR210MDB Diagnostic Module	77
Chapter 6	XCSR210MDB Diagnostic Module	79
	Overview	80
	Description	81
	Connections Configuration	82
	Wiring	84
	Diagnostic LED	85
	Modbus Registers	86
	Operating	90
	Characteristics	92
Glossary	93

DRAFT



Important Information

NOTICE

Read these instructions carefully, and look at the equipment to become familiar with the device before trying to install, operate, or maintain it. The following special messages may appear throughout this documentation or on the equipment to warn of potential hazards or to call attention to information that clarifies or simplifies a procedure.



The addition of this symbol to a “Danger” or “Warning” safety label indicates that an electrical hazard exists which will result in personal injury if the instructions are not followed.



This is the safety alert symbol. It is used to alert you to potential personal injury hazards. Obey all safety messages that follow this symbol to avoid possible injury or death.

DANGER

DANGER indicates a hazardous situation which, if not avoided, **will result in** death or serious injury.

WARNING

WARNING indicates a hazardous situation which, if not avoided, **could result in** death or serious injury.

CAUTION

CAUTION indicates a hazardous situation which, if not avoided, **could result in** minor or moderate injury.

NOTICE

NOTICE is used to address practices not related to physical injury.

PLEASE NOTE

Electrical equipment should be installed, operated, serviced, and maintained only by qualified personnel. No responsibility is assumed by Schneider Electric for any consequences arising out of the use of this material.

A qualified person is one who has skills and knowledge related to the construction and operation of electrical equipment and its installation, and has received safety training to recognize and avoid the hazards involved.

DRAFT

About the Book



At a Glance

Document Scope

This manual describes the features, installation, wiring, usage, and troubleshooting of the XCSR RFID Safety Switches.

Validity Note

The technical characteristics of the devices described in this manual also appear online.

To access this information online:

Step	Action
1	Go to www.tesensors.com .
2	In the Search box, type the model number of a product or the name of a product range. Do not include blank spaces in the model number/product range.
3	If more than one model number appears in the Products search results, click on the model number that interests you.
4	To save or print a data sheet as a .pdf file, click Download product datasheet .

The characteristics that are presented in this manual should be the same as those characteristics that appear online. In line with our policy of constant improvement, we may revise content over time to improve clarity and accuracy. If you see a difference between the manual and online information, use the online information as your reference.

QR Code

A QR code including the Telemecanique Sensors web address is present on the XCSR RFID Safety Switch marking. Technical documents are available in various languages in this website.



Related Documents

Title of documentation	Reference number
XCSR RFID Safety Switches - Quick Start Guide	NHA77770
XCSR D210MDB Diagnostic module - Quick Start Guide	NHA77776

You can download these technical publications and other technical information from our website at www.tesensors.com

User Comments

We welcome your comments about this document. You can reach us by e-mail at customer-support@tesensors.com.

DRAFT

Part I

General

Overview

This part provides detailed information about the safety requirements and product description.

What Is in This Part?

This part contains the following chapters:

Chapter	Chapter Name	Page
1	Safety Requirements	11
2	Product Description	13

DRAFT

DRAFT

Chapter 1

Safety Requirements

Safety Requirements

Precautions

⚠ WARNING
IMPROPER SETUP OR INSTALLATION
<ul style="list-style-type: none">• This equipment must only be installed and serviced by qualified personnel.• Read, understand, and follow the compliance below before installing the XCSR RFID Safety Switches. Failure to follow these instructions can result in death, serious injury, or equipment damage.

Meeting Full Compliance

The compliance of a machine and the XCSR RFID Safety Switches with safety regulations, depends on the proper application, installation, maintenance, and operation of the XCSR RFID Safety Switches. These are responsibilities of the purchaser, installer, and employer.

The employer is responsible for selecting and training the personnel necessary to properly install, operate, and maintain the machine and its safeguarding systems. The XCSR RFID Safety Switches must only be installed, checked, and maintained by a qualified person. A qualified person is defined as “a person or persons who, by possession of a recognized degree or certificate of professional training, or who, by extensive knowledge, training and experience, has successfully demonstrated the ability to solve problems relating to the subject matter and work” (ANSI B30.2).

To use the XCSR RFID Safety Switches, the given requirements must be met:

- The guarded machine must be able to stop anywhere in its cycle.
- The guarded machine must not present metallic chips in the vicinity of the XCSR RFID Safety Switches.
- The guarded machine must have a consistent stopping time and adequate control mechanisms.
- All applicable governmental and local rules, codes, and regulations must be satisfied. This is the user and employer responsibility.
- All safety-related machine control elements must be designed so that an alarm in the control logic or the control circuit breakdown does not lead to a XCSR RFID Safety Switches failure.
- Perform a test of the XCSR RFID Safety Switches during installation and after maintenance or adjustment. As well as in case of any modification of the machine controls, tooling, machine or of the RFID guarding system.
- The proper functioning of the XCSR RFID Safety Switches and its operating line must be checked on a regular basis based on the level of security required by the application (for example, number of operations, level of environmental pollution, ...).
- Perform only the test and diagnostic procedures outlined in this manual.
- Follow all procedures in this manual for proper operation of the XCSR RFID Safety Switches.
- All safety-related machine control circuit elements, including pneumatic, electric, or hydraulic controls must be control-reliable.

The enforcement of these requirements is beyond the control of Schneider Electric. The employer has the sole responsibility to follow the preceding requirements and any other procedures, conditions, and requirements specific to the machinery.

Product Support

For more information about products and services in your country, visit www.tesensors.com.

DRAFT

Chapter 2

Product Description

Overview

This chapter describes the general information, XCSR RFID Safety Switch functions, and system components.

What Is in This Chapter?

This chapter contains the following sections:

Section	Topic	Page
2.1	General Information	14
2.2	XCSR RFID Safety Switch Functions	22
2.3	System Components	37

DRAFT

Section 2.1

General Information

Overview

This section describes general information of the XCSR RFID Safety Switches.

What Is in This Section?

This section contains the following topics:

Topic	Page
XCSR RFID Safety Switch General Description	15
How a XCSR RFID Safety Switch Works?	16
Operating Zones (S_{ao} – S_{ar})	17
Definition of Characteristic Times	18
System Response Time (Process Safety Time)	19
Risk Assessment	20

DRAFT

XCSR RFID Safety Switch General Description

Overview

The XCSR RFID Safety Switches are used where personnel protection is required. The basic applications are for monitoring the position of movable safety guards to prevent hazardous situations from occurring when the safety guard is opened. Such as, for example:

- Robotic work cells
- Mobile equipments
- Transfer lines
- Assembly lines
- Roll handling equipments
- Automated equipments
- Machine tools
- Food and beverage equipments
- Packaging machines

DRAFT

How a XCSR RFID Safety Switch Works?

General Description

A XCSR RFID Safety Switch is a contactless system that consists of a microprocessor-controlled switch (also called "sensor" or "reader") and a transponder (also called "tag" or "coded actuator").

The reader is to be mounted on the fixed part of the safety guard, and the transponder on the mobile part. There is no contact between the transponder and the switch, a radio-frequency technology is used for the communication.

The reader and the transponder are paired in factory. During the manufacturing, the reader loads into the transponder with which it is sold, a unique code. This saved digital code is the unique "key" accepted by the paired reader.

When the transponder enters the radio frequency field generated by the reader (by closing a guard door for example), the reader detects the transponder and reads the data in the transponder memory.

If the transponder code demanded by the reader is correct, the reader switches its two redundant safety outputs (OSSDs) to the **ON** state, indicating that the safety guard is closed and thus allowing the machine operation. For more details, refer to XCSR RFID Safety Switch Functions ([see page 22](#)).

When the transponder goes outside the field generated by the reader (by opening a guard door for example) the reader switches its two redundant safety outputs (OSSDs) to the **OFF** state in order to stop the machine, indicating that the safety guard is opened.

By the use of a unique coding, RFID technology is robust against tampering (Type 4 - High level of coding - according to ISO 14119).

A transponder cannot be reprogrammed. If for any reason, like a tampering attempt, the reader does not receive from a transponder the only expected code saved in factory, the communication with the transponder is rejected by the reader. The reader then enters in Error mode and switches its safety outputs to the **OFF** state. A new power-up is then required. XCSR RFID Safety Switch is designed to be compliant with the safety requirements PLe - Cat 4 (EN ISO 13849-1), SIL3 (IEC 61508) and SILCL3 (IEC 62061).

This illustration presents the XCSR RFID Safety Switch:

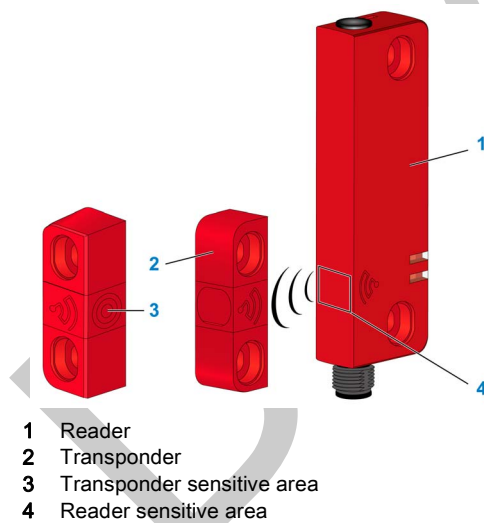

Operating Zones (S_{ao} – S_{ar})

General Description

When paired transponder and reader are both operating:

- S_{ao} (Assured operating sensing distance) is the distance from the sensing face within which the presence of the specified target is correctly detected under all specified environmental conditions (for example: operating temperature, material of the mounting support) and manufacturing tolerances.
- S_{ar} (Assured release sensing distance) is the distance from the sensing face beyond which the absence of the specified target is correctly detected under all specified environmental conditions (e.g operating temperature, material of the mounting support) and manufacturing tolerances.
- The value of S_{ao} is the switching distance below which the **ON** state is defined with an absolute certainty (the black area in the drawing hereunder = OSSDs **ON**)
- The value of S_{ar} is the switching distance beyond which the **OFF** state is defined with an absolute certainty (the white area in the drawing hereunder = OSSDs **OFF**)
- S_r is the real switch-on sensing distance.

The gray zone represents the “transient state”. Inside the gray area, the commutation points are thus not guaranteed (dispersions zone).

S_{ao} and S_{ar} values depend on the approach directions and the misalignment between the transponder and the reader (refer to Mounting and Operating Distances ([see page 45](#))).

The reader and the transponder parts must be mounted in accordance with the given S_{ao} and S_{ar} values to ensure a switch **ON** and a switch **OFF** respectively in the black ($<S_{ao}$) and white ($>S_{ar}$) areas.

This diagram describes the operating zones:

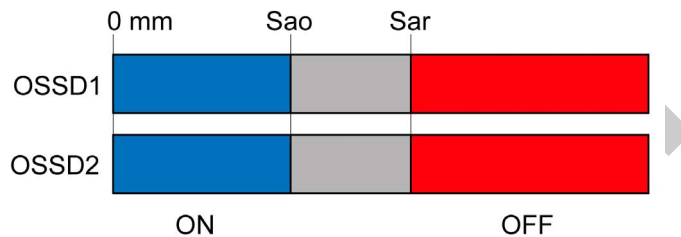

Guaranteed sensing distances for XCSR RFID Safety Switch are given in face to face configuration and without misalignment between the transponder and the reader:

- $S_{ao} = 10 \text{ mm}$ (0.39 in)
- $S_{ar} = 35 \text{ mm}$ (1.38 in)
- **Hysteresis:** $3\% \times S_r \leq H_r \leq 20\% \times S_r$

Refer to face to face mounting configuration ([see page 47](#)).

A slight delay between the switching of the two OSSDs exists and is defined as the “OSSDs Delay Time (T_{DT})” ([see page 18](#)).

Definition of Characteristic Times

Response Time (T_t)

Time between the transponder is entering the operating zone, and the switching of the OSSDs to the **ON** state. Typical $T_t = 120$ ms. This time applies for only one reader. In daisy-chain configuration, each additional switch increases this time by 50 ms.

For Standalone models, the typical response time is $T_t = 250$ ms.

Risk Time (T_r)

Time between the transponder is leaving the operating zone, and the switching of the OSSDs to the **OFF** state. $T_r < 120$ ms. This time applies for only one reader. In daisy-chain configuration, each additional switch increases this time by 18 ms.

First-up Time (T_{ON})

After a power-up, the system is performing self-tests for checking its integrity. The first-up time is the delay, from power-up, after which the system is ready for operation. $T_{ON} < 5$ s.

Pairing Mode Time (T_{PM})

Time during which a new transponder pairing is possible (for "re-pairing enabled models" only).

$T_{PM} = 10$ s from First-up Time (T_{ON}) (10 s after the initialization phase).

Safety Inputs Inconsistency Time (T_{IT})

For daisy-chain configuration, maximum time-out allowed for an inconsistency between the states of the two safety-related inputs. If the time-out is over with a persistent discrepancy, the OSSDs switch to the **OFF** state. $T_{IT} < 18$ ms.

OSSDs Delay Time (T_{DT})

Defines the time difference between the OSSDs for switching to the OFF state. $T_{DT} < 18$ ms.

OSSDs Pulse Time (T_{PT})

This time is the width of the periodic pulses generated on each OSSD to perform the monitoring of the safety outputs (short-circuit detection for example). This pulse duration must be compatible with the downstream equipment connected to the OSSDs (safety interface for example). $T_{PT} \text{ max} = 1.4$ ms, duty cycle maximum 300 ms.

System Response Time (Process Safety Time)

General Description

According to EN ISO 13855, the total response time (T) corresponding to the overall system stopping performance is calculated by the given formula:

$$T = t_1 + t_2$$

Where:

t_1 = Response time of the protection system (in second). It is the total time between the actuation of the safeguard and the switching to the OFF state of its output components. This time corresponds to the "Risk Time" (T_r)

t_2 = Stopping time of the machine (in seconds): maximum time required to terminate the hazardous machine function after the output signal from the safeguard achieves the OFF-state. This information is supplied by the machine manufacturer. The response time of the control and the output systems of the machine is included in t_2 .

WARNING

IMPROPER SETUP

- Ensure that the XCSR RFID Safety Switch is mounted far enough away from the operations hazard to fully accommodate the stopping time.
- When using a safety interface like safety relays or controllers, the response time of the safety interface must be added to the overall system stopping time.

Failure to follow these instructions can result in death, serious injury, or equipment damage.

Risk Assessment

General Description

Risk assessment and risk reduction are **iterative processes** described in EN ISO 12100, IEC 61508 & IEC 62061 (SIL and SILCL), and EN ISO 13849-1 (PL). There are various techniques for risk assessment, and not one of it can be considered as the right way to perform risk assessment. The standard specifies some general principles but does not specify exactly what has to be done in each case.

For safety-related data, refer to Safety Related Data section (*see page 69*).

This flowchart describes the risk assessment process:

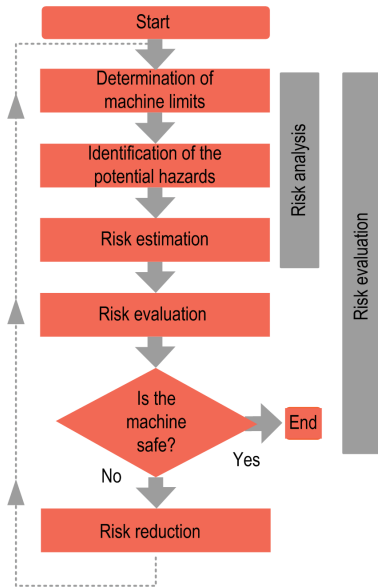

Essential steps for risk assessment are the following:

- Define tolerable risk level.
- Identify hazards.
- Analyze hazards.
- Determine whether the risks are below an acceptable level.
- Define protection measures if risks are above a tolerable level.
- Check whether protection measures taken lead to an effective risk reduction (Iterative process).

This figure describes the elements of risk to take into account for the risk estimation:

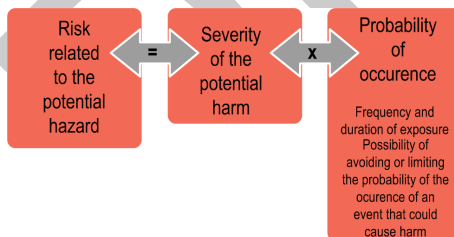

⚠ WARNING

IMPROPER TYPE UTILIZATION

It is the responsibility of the user or integrator to check whether the use of the XCSR RFID Safety Switch is consistent with the application risk assessment.

To choose the right product for your application, perform a risk assessment.

Failure to follow these instructions can result in death, serious injury, or equipment damage.

For more information, refer to: <http://www.schneider-electric.com/ww/en/download/document/DIA4ED1100102EN>.

Reference Standards

The following table describes the main reference standards:

Standard	Risk assessment	Description
EN ISO 12100	Risk assessment and risk reduction	Safety of machinery. General principles for design. Risk assessment and risk reduction.

Standard	Safety level	Description
EN ISO 13849-1	Performance level (PL)	Safety-related part of control system. General principles for design.
	Category (Cat)	
IEC 61508	Safety integrity level (SIL)	Functional safety of electrical/electronic/programmable electronic safety-related systems.
IEC 62061	Safety integrity level claim limit (SILCL)	Safety of machinery. Functional safety of safety-related electrical, electronic, and programmable electronic control systems.

Standard	Type-B standards	Description
ISO 14119	Safeguards (interlocking devices)	Safety of machinery. Interlocking devices associated with guards. Principles for design and selection.
EN/IEC 60947-5-2	Low-voltage switchgear and controlgear	Control circuit devices and switching elements. Proximity switches.
EN/IEC 60947-5-3	Low-voltage switchgear and controlgear	Control circuit devices and switching elements. Requirements for proximity devices with defined behavior under fault found conditions (PDDB).

Section 2.2

XCSR RFID Safety Switch Functions

Overview

This section describes the various functions of XCSR RFID Safety Switch.

What Is in This Section?

This section contains the following topics:

Topic	Page
Operating Modes	23
External Device Monitoring (EDM) or Machine Primary Control Element (MPCE) Monitoring	25
Operating and Output States, LED Meaning	26
XCSR Standalone Models	28
XCSR Series Connection (Daisy-Chain)	30
XCSR Single Models	33
Pairing Modes	35

DRAFT

Operating Modes

Introduction

The operating mode determines the start-up and operating behavior of the XCSR RFID Safety Switch. The operating mode descriptions in this section are derived from the operating state definitions (*see page 26*).

Automatic Start

In this mode, the system enters the **Run** state after startup without operator intervention, as long as the paired transponder is in the reader detection zone. When the XCSR RFID Safety Switch is powered up, it enters the initialization phase during which its safety outputs are **OFF**. If no faults are detected and the safety guard is closed, it enters the **Run** state (*see page 26*) after 5 seconds maximum (refer to T_{ON} First-up Time (*see page 18*)) and the two safety outputs switch to **ON** state. In this state, when the transponder leaves the operating zone (safety guard opening), the XCSR RFID Safety Switch changes from **Run** state to **Stop** state (*see page 26*) (the two safety outputs switch to **OFF** state), and remains in the **Stop** state until the paired transponder enters again the detection zone (without any fault detected): the XCSR RFID Safety Switch then automatically changes from **Stop** state to **Run** state and the two safety outputs switch to **ON** state.

Automatic Start is available on XCSRC•1AM12 standalone models

WARNING

IMPROPER AUTOMATIC START UTILIZATION

The manual Start/Restart is required in most safety applications. If you use the automatic start function, check that this automatic start mode is compatible with risk assessment performed for the application.

Failure to follow these instructions can result in death, serious injury, or equipment damage.

Manual Start/Restart

When the XCSR RFID Safety Switch is powered up, it enters the initialization phase during which its safety outputs are **OFF**. If no faults are detected after the first-up time, it enters the Start/Restart state. To enter the **Run** state and switch the OSSDs to **ON**, the paired transponder must be in the reader detection zone, no faults detected, and the operator must press and release ("monitored start") the **Start** button. Then, if the XCSR RFID Safety Switch leaves the detection zone when it is in **Run** state, the XCSR RFID Safety Switch changes to **Stop** state and the safety outputs change from **ON** to **OFF** state.

If the paired transponder enters the detection zone again (and no faults are detected), the safety outputs stay at the **OFF** state until the push button is actuated.

WARNING

UNINTENDED EQUIPMENT OPERATION

Follow the requirements concerning start/restart operating modes defined in ISO 12100:

- "Requirements for interlocking guards with a start function (control guards)" section.

The Restart command must be installed outside the dangerous area in such way that the whole working and hazardous areas are observable. You must not access the Start/Restart command inside the hazard area.

Failure to follow these instructions can result in death, serious injury, or equipment damage.

NOTICE

UNINTENDED EQUIPMENT OPERATION

For "monitored manual Start/Restart", the command is effective after the operator has pressed and released the **Start** button, which means a transition sequence 0 Vdc → 24 Vdc → 0 Vdc on the start command. The minimum duration of this sequence must be between 200 ms and 5 s. Beyond the 5 s, the release action on the command will not activate the XCSR RFID Safety Switch. The operator will have to repeat the start/restart sequence and release the command before 5 s.

The "monitored manual Start/Restart" is available exclusively on XCSRC•1MM12 standalone models.

For Single and Daisy-Chain XCSR RFID Safety Switch models, refer to the safety interface operating instructions.

Failure to follow these instructions can result in equipment damage.

DRAFT

External Device Monitoring (EDM) or Machine Primary Control Element (MPCE) Monitoring

General Description

EDM monitoring is an important safety function.

The EDM monitors the interface between XCSR RFID Safety Switch and the guarded machine to:

- Confirm that the external devices such as switching devices like contactors are responding correctly to the XCSR safety outputs.
- Detect any inconsistency between the two external devices (that is, control relays or contactors) which could prevent a stop signal from reaching the machine primary control elements (for example, power contactors or electrovalve relays).

The EDM controls the external contactors KM1/KM2 connected to the two OSSDs. To achieve this, normally closed contacts of the external contactors are monitored.

To perform this function, the contactors KM1/KM2 must have:

- Normally closed mirror contact, according to IEC 60947-4-1 (Annex F) for power contactors.
- Linked contacts (or force-guided contacts), according to IEC 60947-5-1 (Annex L) or EN 50205 for auxiliary contactors or control relays.

XCSR RFID Safety Switch standalone models have built-in EDM function. For Daisy-Chain and Single models, refer to the safety interface operating instructions (e.g safety relay or safety controller).

To manage the EDM function, refer to wiring instructions ([see page 54](#)).

DRAFT

Operating and Output States, LED Meaning

Introduction

This figure describes the Diagnostic LED of the XCSR reader:

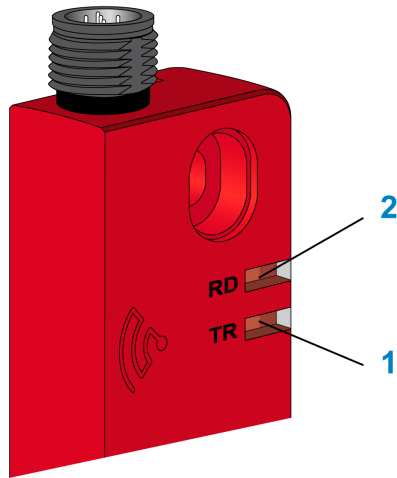

LED 1 (TR) Transponder state
LED 2 (RD) Reader/Output state

Diagnostic LED Meanings

This table describes the operating and output states with LED meanings and output states of the XCSR RFID Safety Switch:

Operating state	LED 1 Transponder	LED 2 Reader	OSSDs	LEDs meaning	Comment
OFF	OFF	OFF	OFF	XCSR reader is unpowered	-
Initialization	Orange	Orange	OFF	XCSR reader initialization in progress	-
Configuration	Orange Fast blinking	Orange Fast blinking	OFF	XCSR reader is in configuration mode	-
	Green	Orange Fast blinking	OFF	Pairing with new transponder done: new power-up required	Only for "re-pairing enabled models"
	Orange Blinking	Red	OFF	Maximum of pairing reached	-
	Red Blinking	Red	OFF	Invalid transponder detected	Transponder not blank or not Telemecanique transponder
	Orange Fast blinking	Red	OFF	Pairing process unsuccessful	Only for "re-pairing enabled models"
Run	Green	Orange Blinking	OFF	Paired transponder detected: waiting for the start condition and/or KM1_KM2 feedback (EDM)	Only for standalone versions
	Green	Green	ON	Paired transponder detected and all other operating conditions are correct	Door closed
	Green	Red	OFF	Paired transponder detected but the safety inputs are at the OFF state.	For Daisy-Chain models: at least one of the previous readers has its OSSDs at the OFF state (door opened, error detected or OFF state)
	OFF	Red	OFF	No transponder in the field	Door opened

Operating state	LED 1 Transponder	LED 2 Reader	OSSDs	LEDs meaning	Comment
Error detected	Red Blinking	Red Blinking	OFF	Invalid transponder or non-paired transponder detected: new power-up required after fault clearance	Possible attempted fraud or transponder damaged
	Green or OFF	1, 2, 3, or 4 red flashes	OFF	Internal error detected. Contact the customer support of your country.	The color of the LED 1 depends on the presence of the transponder: <ul style="list-style-type: none"> ● Green: transponder detected ● OFF: no transponder detected

DRAFT

XCSR Standalone Models

General Description

Special models of the XCSR RFID Safety Switches (XCSRC•1•M12) are designed to be used as standalone products, when associated with contactors having mechanically linked contacts (force-guided) connected to the OSSDs that is, without any safety relay, controller, or PLC. In standalone operation, the two OSSDs are connected directly to the contactors. This connection is made through a pre-wired 8 pins M12 connector.

Refer to Connection Schematics (*see page 56*).

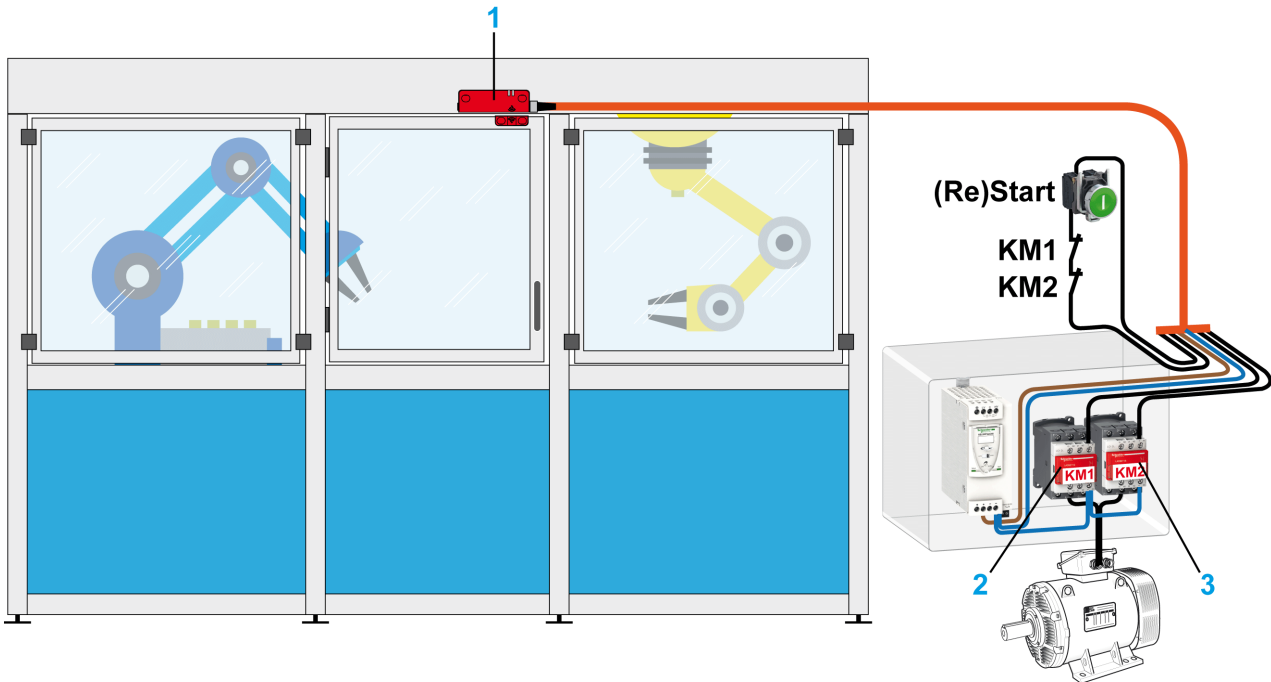

- 1 XCSRC•1MM12: XCSR RFID Safety Switch standalone model
- 2 KM1: contactor 1 - OSSD1
- 3 KM2: contactor 2 - OSSD2

⚠ WARNING

UNINTENDED EQUIPMENT OPERATION

The KM1 and KM2 contactors must have force-guided contacts.

Failure to follow these instructions can result in death, serious injury, or equipment damage.

NOTICE

UNINTENDED EQUIPMENT OPERATION

Use of arc suppressors for KM1 & KM2 is recommended.

Failure to follow these instructions can result in equipment damage.

Features and Requirements

The XCSR RFID Safety Switch standalone models have the given features and requirements:

- 2 OSSDs
- External Device Monitoring (EDM) (selected by wiring)
- Start feature:
 - Monitored manual Start/Restart: XCSR•1MM12
 - Automatic Start: XCSR•1AM12

XCSRC•1•M12 standalone models are compliant with the following safety standards SIL3 (IEC 61508) SILCL3 (IEC 62061), and PLe- Cat.4 (EN ISO 13849-1)

It is the aim of the risk analysis to determine whether the use of XCSRC•1•M12 standalone models are compatible with the expected safety integrity level of the entire system.

⚠ WARNING

IMPROPER UTILIZATION

It is the responsibility of the user or integrator to check whether the use of standalone XCSR RFID Safety Switch is consistent with the application risk assessment.

Perform a risk assessment to choose the right product for your application.

Failure to follow these instructions can result in death, serious injury, or equipment damage.

DRAFT

XCSR Series Connection (Daisy-Chain)

General Description

XCSRC•2M12 models of XCSR RFID Safety Switches can be connected in series. The daisy-chain function allows multiple safety guards to be connected in series.

Thanks to their integrated connection means, the readers can be easily wired without using additional "T" or "Y" connectors. These connection means are two M12 5 pins male connectors (a reader by-pass is less easy to operate than if it was male/female connectors).

A direct connection between the XCSR readers can thus be made by using female/female M12 5 pins cables (see cable references (see page 74)).

Refer to Connection Schematics (see page 52).

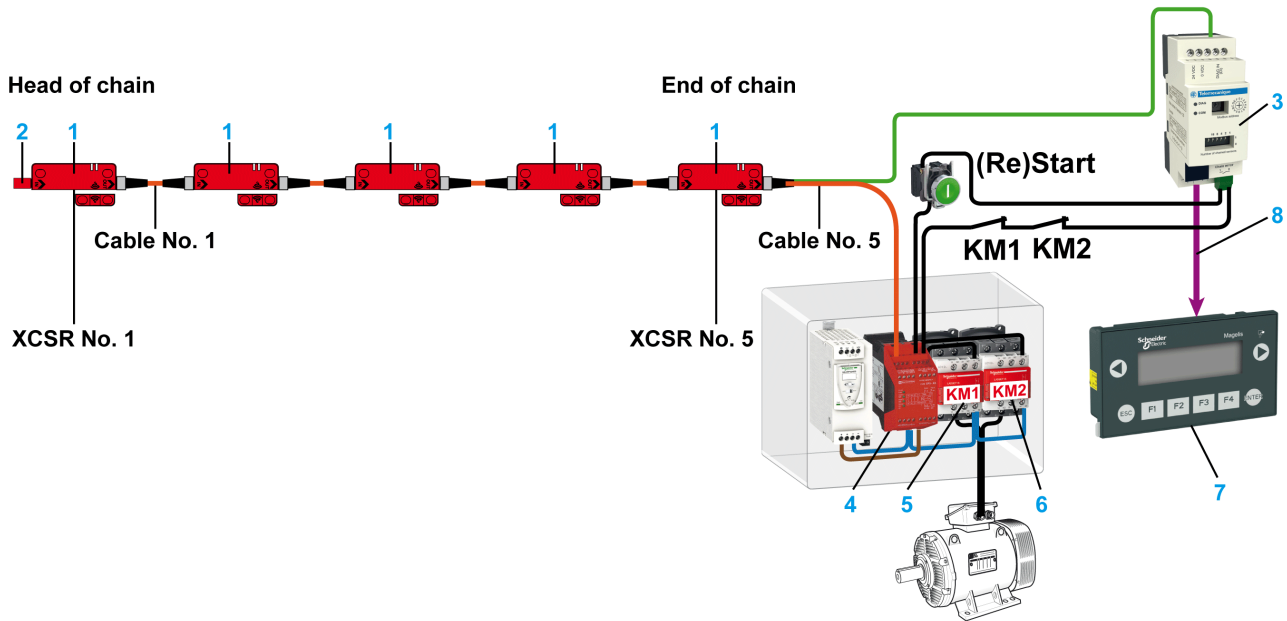

- 1 XCSRC•2M12: XCSR RFID Safety Switch Daisy-Chain model
- 2 XCSRZE: Loopback device
- 3 XCSR210MDB: Diagnostic module
- 4 XPSAK***: Safety relay
- 5 KM1: contactor 1 - OSSD1
- 6 KM2: contactor 2 - OSSD2
- 7 XBTN***: Magelis Terminal (programming cable RJ45/USB: TCSMCNAM3M002P)
- 8 VW3A8306R** 2xRJ45 Modbus cable

⚠ WARNING

UNINTENDED EQUIPMENT OPERATION

The KM1 and KM2 contactors must have force-guided contacts.

Failure to follow these instructions can result in death, serious injury, or equipment damage.

Features and Requirements

Daisy-chain XCSRC•2M12 models have the given features and requirements:

- 2 OSSDs.
- Up to 20 XCSRC•2M12 can be connected in series.
- Up to 5 XCSRC•2M12 connected in series, the maximum length between each XCSRC•2M12 is 30 m (98.4 ft.).
- For higher numbers of XCSRC•2M12, the maximum cable length allowed between each XCSRC•2M12 decreases. For example, for 10 XCSRC•2M12 connected in series, the maximum length between each XCSRC•2M12 is 10 m (32.8 ft.).
- The association with a safety interface (safety relay or controller for example) is mandatory.
- External Device Monitoring (EDM) and Start/Restart conditions to be managed by a safety interface.

- A M12 plug (XCSRZE) must be connected to the reader which starts the chain (loopback device).
- Recommended diagnosis of the chain status with the XCSR210MDB diagnostic module (see page 77).

⚠ WARNING
IMPROPER CONNECTION
The safety inputs of the safety interface must be suitable to XCSR OSSDs pulsed signals specified in XCSR RFID Safety Switch specification - Characteristics Time (see page 66).
Failure to follow these instructions can result in death, serious injury, or equipment damage.

⚠ WARNING
IMPROPER CONNECTION
The diagnostic module, every XCSRC•2M12, and the safety interface must be powered by the same power supply.
Failure to follow these instructions can result in death, serious injury, or equipment damage.

Daisy-chain models XCSRC•2M12 are compliant with the following safety standards:

- SIL3 (IEC 61508) SILCL3 (IEC 62061), and PLe- Cat.4 (EN ISO 13849-1)
- The overall safety integrity level of the system must consider the number of XCSRC•2M12 switches connected in series but also the reliability data of the signal processing unit and the output system.

According to EN ISO 13849-1 and/or EN IEC 62061, the PFH_D corresponding to a SIL3 integrity level of a safety function must be within the following limits:

$$10^{-7} \geq PFH_D \geq 10^{-8}$$

PFH_D = average probability of dangerous failure per hour for high demand or continuous mode of operation

The contribution to the total PFH_D of the switches, the signal processing unit, and the output system depends on the reliability data of the devices used in the application.

An example of PFH_D contribution of an entire safety function is given below:

XCSR••	XPSAFL••	TeSys redundant contactor:
PFH _D = 5x10 ⁻¹⁰ per switch	PFH _D = 5.6x10 ⁻⁹	PFH _D = 24.7x10 ⁻⁹
		
Switches	Logic Treatment	Pre-actuators/Actuators

Theoretical maximum number of switches connectable in series

In this example, the maximum PFH_D allowed for the series connection is:

$$[PFH_{Dmax}] \text{ switches} = 1x10^{-7} - 5.6x10^{-9} - 24.7x10^{-9} = 69.7x10^{-9}$$

The PFH_D of one XCSR RFID Safety Switch is 5x10⁻¹⁰, it means that the **theoretical** maximum number of XCSR RFID Safety Switch that could be connected in series, without impacting the overall safety level (SIL3-PLe) would be N_{max} = 69.7x10⁻⁹/5x10⁻¹⁰ = 139

Thus, the maximum number of chainable switches will be more limited by electrical constraints

Practical maximum number of switches connectable in series

In practice, by considering a realistic number of switches which could be connected in series as well as electrical limitations, the maximum number of XCSR RFID Safety Switch that can be connected in series has been limited to 20.

⚠ WARNING

UNINTENDED EQUIPMENT OPERATION

The maximum number of switches that can be connected in series depends on different factors:

- The overall safety integrity level expected for the application.
- The cable length between each XCSR reader,
- The output current,
- The input voltage,
- The wire cross section (see Electrical connections (*see page 52*)),

Failure to follow these instructions can result in death, serious injury, or equipment damage.

⚠ WARNING

IMPROPER UTILIZATION

It is the responsibility of the user or integrator to check whether the use of daisy-chain XCSR RFID Safety Switch is consistent with the application risk assessment.

Perform a risk assessment to choose the right product for your application.

Failure to follow these instructions can result in death, serious injury, or equipment damage.

DRAFT

XCSR Single Models

General Description

XCSRC•0M12 references are suitable for monitoring multiple safeguards by point-to-point connections to a safety interface (safety controller or safety PLC for example).

Refer to connection schematics (*see page 56*).

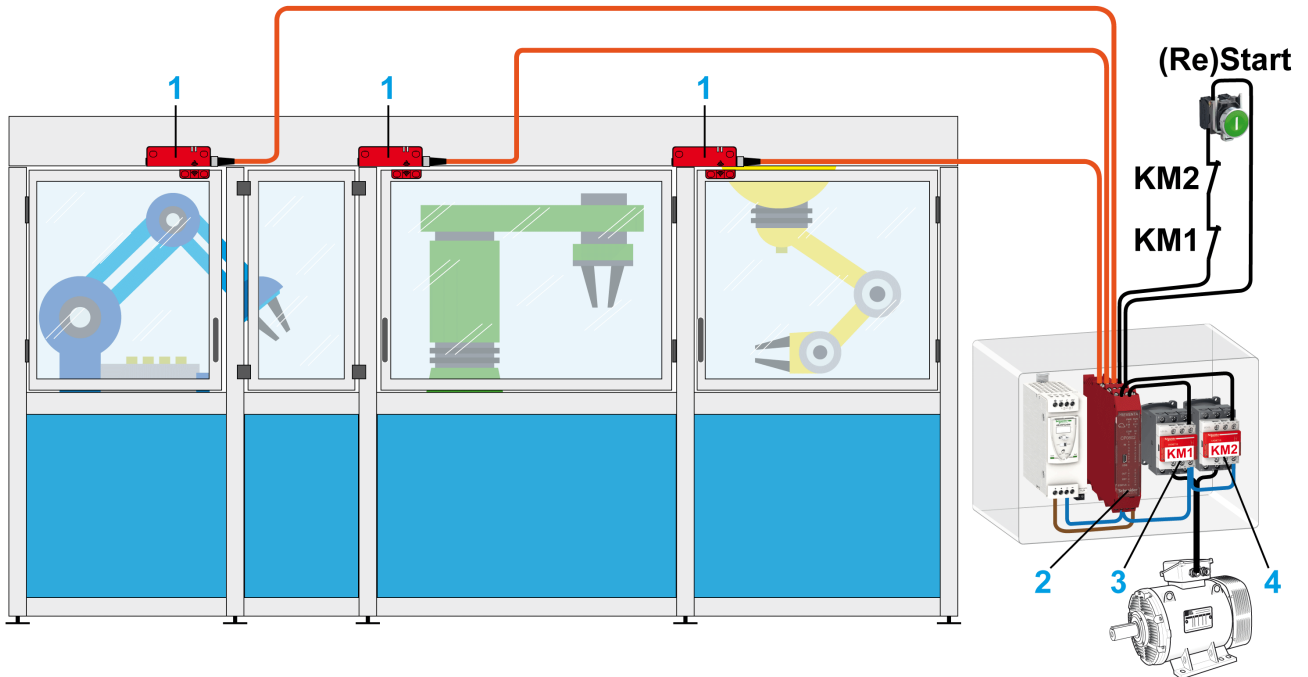

- 1 XCSRC•0M12: XCSR RFID Safety Switch single model
- 2 XPSMCMCP0802: safety controller
- 3 KM1: contactor 1 - OSSD1
- 4 KM2: contactor 2 - OSSD2

The association of the XCSR readers is, in this case, made by software at the safety interface level.

⚠ WARNING

UNINTENDED EQUIPMENT OPERATION

The KM1 and KM2 contactors must have force-guided contacts.

Failure to follow these instructions can result in death, serious injury, or equipment damage.

Features and Requirements

Single XCSRC•0M12 models have the given features and requirements:

- 2 OSSDs.
- The association with a safety interface (safety controller for example) is mandatory.
- The External Device Monitoring (EDM) and Start/Restart conditions must be managed by a safety interface.

⚠ WARNING

IMPROPER CONNECTION

The safety inputs of the safety interface must be suitable to XCSR OSSDs pulsed signals specified in XCSR RFID Safety Switch specification - Characteristics Time (*see page 66*).

Failure to follow these instructions can result in death, serious injury, or equipment damage.

Single models XCSRC•0M12 are compliant with the following safety standards:

- SIL3 (IEC 61508) SILCL3 (IEC 62061), and PLe- Cat.4 (EN ISO 13849-1)
- The overall safety integrity level of the system must consider the configuration of XCSRC•0M12 switches connected but also the reliability data of the signal processing unit and the output system.

It is the aim of the risk analysis to determine whether the use of single models XCSRC•0M12 are compatible with the expected safety integrity level of the entire system.

⚠ WARNING

IMPROPER UTILIZATION

It is the responsibility of the user or integrator to check whether the use of single XCSR RFID Safety Switch is consistent with the application risk assessment.

Perform a risk assessment to choose the right product for your application.

Failure to follow these instructions can result in death, serious injury, or equipment damage.

DRAFT

Pairing Modes

General Description

For every model (standalone, daisy-chain and single), two references corresponding to two different pairing modes are available:

- **XCSRC1•M12** “Unique pairing” models: **Unique Code, digital code saved in factory. New transponder pairing is impossible.**

In case of transponder damage, the transponder and the reader must be both replaced.

- **XCSRC3•M12** “re-pairing enabled” models: **Unique Code, digital code saved in factory. Two new (blank) transponder pairings are possible (and only two).**

In case of transponder damage, a new blank transponder can be paired by the reader within a limit of two new transponder pairings. Blank transponders are available as spare parts (XCSRK2A3).

A new transponder pairing removes definitely the previous code saved in the reader. The previous transponder is thus no longer usable.

The transponder pairing is an automatic procedure initialized at the power-up phase.

The pairing mode (configuration state) is available during 10 s after the initialization phase.

NOTE: A transponder is paired only one single time and can never be reprogrammed.

Pairing procedure for XCSRC3•M12 models:

During the 10 s following the initialization phase, a blank transponder XCSRK2A3 must be placed in the detection zone (at a distance $\leq S_{a0}$, see NOTICE below) and the new pairing will be automatically performed. The previous transponder data are removed from the reader memory. A new power-up is then required.

The new transponder pairing will be rejected in the following cases:

- Transponder not blank
- Transponder blank but wrong ID
- Transponder correct but number of pairings memorized by the reader ≥ 2
- The reader is a unique pairing reference (**XCSRC1•M12**)

NOTICE

UNINTENDED EQUIPMENT OPERATION

- For a new pairing operation, the transponder must be placed and maintained at a distance $\leq S_{a0}$, without misalignment with the reader, until the end of the pairing operation.
- During a transponder pairing process, do not place other transponder in the detection area.

Failure to follow these instructions can result in equipment damage.

⚠ WARNING

UNINTENDED EQUIPMENT OPERATION

The possibility to pair up to two new blank transponders, provides flexibility in case of transponder damages. However, the integrity of the safety system is reduced due to the availability of actuators as spare parts which could increase the possibilities of tampering.

Strict procedures must be implemented in order to control the access to these blank transponders and to their use.

Failure to follow these instructions can result in death, serious injury, or equipment damage.

Pairing number

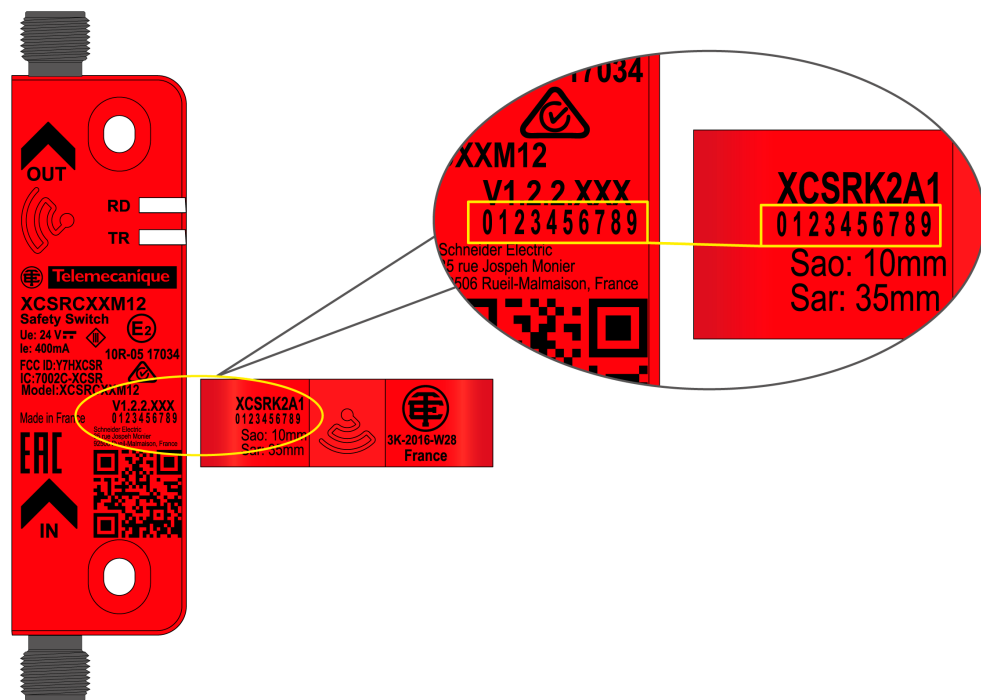

NOTE: During the factory pairing phase, a same traceability number is printed on both parts (transponder and reader).

Section 2.3

System Components

Overview

This section describes the system components and the main features of the XCSR RFID Safety Switches.

What Is in This Section?

This section contains the following topics:

Topic	Page
System Components Identification	38
XCSR Features	39

DRAFT

System Components Identification

General Description

This figure displays the system components:

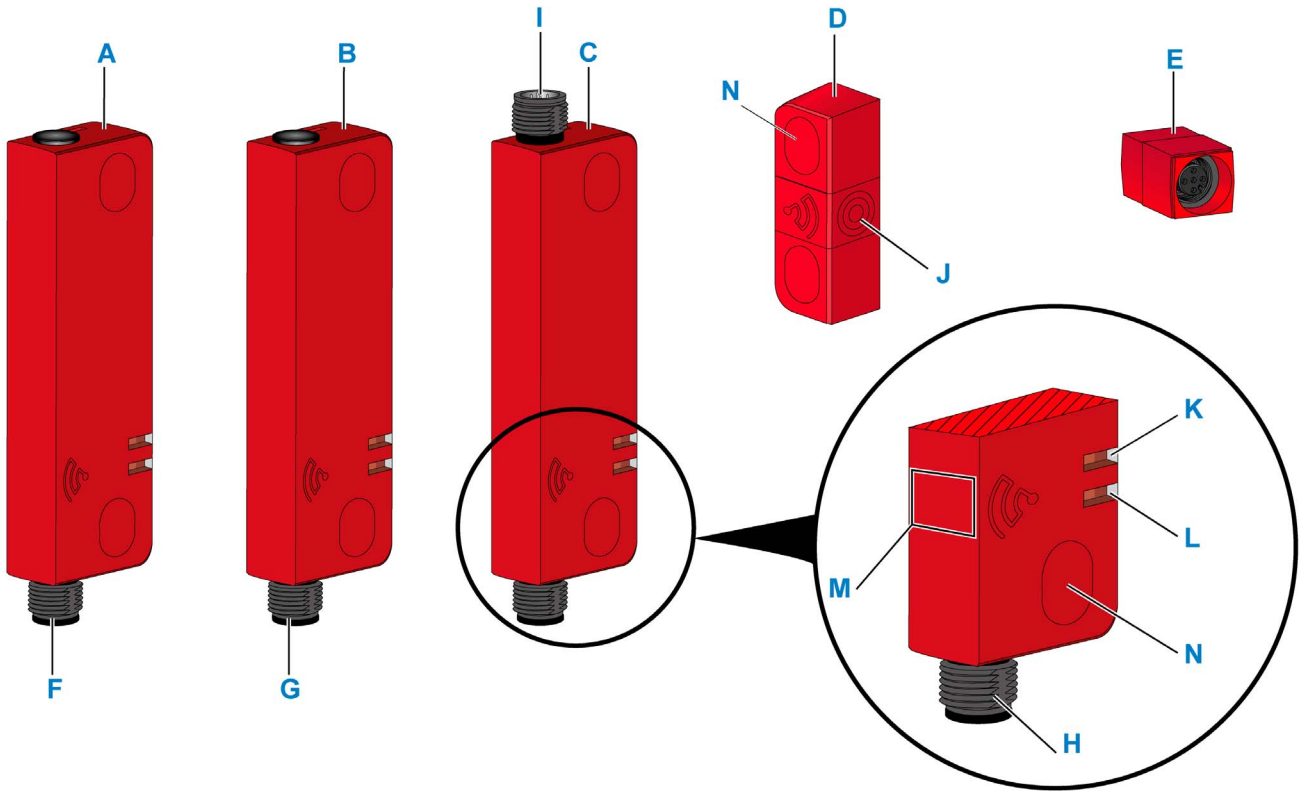

This table describes the system components:

Component	Description	Component	Description
A	XCSRC•0M12: Single	F	M12 5 pins male connector
B	XCSRC•1•M12: Standalone	G	M12 8 pins male connector
C	XCSRC•2M12: Daisy-chain	H, I	M12 5 pins male connector
D	Transponder	J	Transponder sensitive area
E	Loopback device M12	M	Reader sensitive area
K	Visualization of transponder state	N	Blanking plugs
L	Visualization of reader state		

XCSR Features

Features

This table describes the main standard features of XCSR RFID Safety Switches:

Features	XCSRC•0M12	XCSRC•1•M12	XCSRC•2M12
	Single	Standalone	Daisy-chain
Two PNP safety outputs (OSSDs)	✓	✓	✓
Automatic start/restart	–	XCSRC•1AM12	–
Monitored manual start	–	XCSRC•1MM12	–
External Device Monitoring (EDM) feedback input	–	✓	–
EDM & Automatic/manual start/restart through safety interface	✓	–	✓
Transponder with rotating sensitive face	✓	✓	✓
Direct series connection (daisy-chain)	–	–	✓
Point-to-point connection to a safety interface	✓	–	–
Chain diagnosis through XCSRD210MDB diagnostic module	–	–	✓
LED indicators for status and diagnosis	✓	✓	✓
Non-shielded M12 pre-wired cables (<i>see page 74</i>) (to be ordered separately)	✓	✓	✓
References for unique code - Unique pairing	XCSRC10M12	XCSRC11•M12	XCSRC12M12
References for unique code - two new transponder pairings possible	XCSRC30M12	XCSRC31•M12	XCSRC32M12
✓ indicates feature availability in the corresponding XCSR RFID Safety Switch model.			

DRAFT

Part II

Installation, Wiring, and Startup

Overview

This section provides information about installation, wiring, and startup.

WARNING

IMPROPER SETUP

- Read the information in this section completely before starting the installation procedures (*see page 45*).
- The XCSR RFID Safety Switch must be installed, checked, and maintained by qualified personnel as defined in the Meeting Full Compliance (*see page 11*).
- The user must be familiar with the installation requirements, system controls, and features before using the XCSR RFID Safety Switch.

Failure to follow these instructions can result in death, serious injury, or equipment damage.

WARNING

UNINTENDED EQUIPMENT OPERATION

- Check the correct operation of the XCSR RFID Safety Switch at power-up phases and before each shift.
- Presence of metallic chips (even small) in the vicinity of the XCSR RFID Safety Switch can modify the sensing distance.

Failure to follow these instructions can result in death, serious injury, or equipment damage.

What Is in This Part?

This part contains the following chapters:

Chapter	Chapter Name	Page
3	Installation	43
4	Wiring	51

DRAFT

Chapter 3

Installation

Overview

This chapter describes the installation of the XCSR RFID Safety Switches.

What Is in This Chapter?

This chapter contains the following topics:

Topic	Page
Parts List	44
Mounting the XCSR RFID Safety Switch	45

DRAFT

Parts List

Parts

This figure displays the different parts of the XCSR RFID Safety Switch:

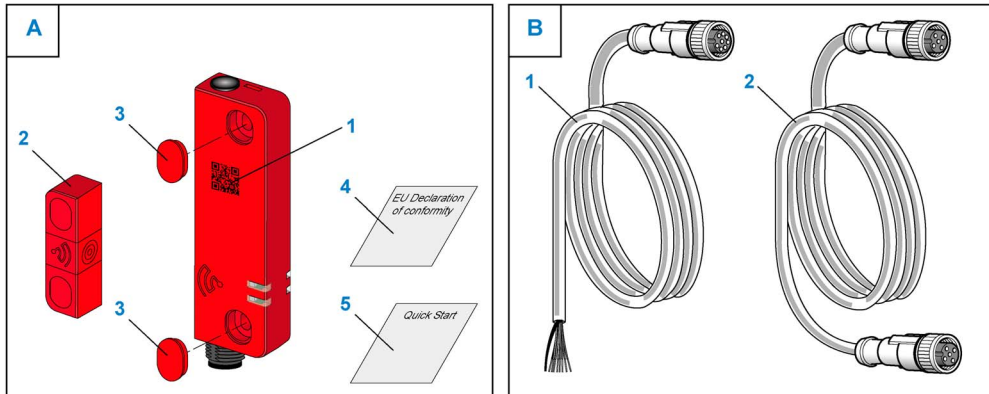

A. The XCSR RFID Safety Switch package includes:

1. XCSR Reader (paired in factory) with QR code ([see page 7](#))
2. XCSR Transponder (paired in factory)
3. 4 x Blanking plugs
4. EU Declaration of conformity
5. Quick start guide

B. M12 pre-wired connection cables ([see page 74](#)) (to be ordered separately):

1. Reader connection cable: female M12 5 or 8 pins pre-wired
2. Reader interconnections (daisy-chain): female/female M12 5 pins

Mounting the XCSR RFID Safety Switch

Overview

⚠ WARNING

UNINTENDED EQUIPMENT OPERATION

The operating distances depend on the approach direction.

Before mounting the XCSR RFID Safety Switch, refer to this section.

Failure to follow these instructions can result in death, serious injury, or equipment damage.

Mounting

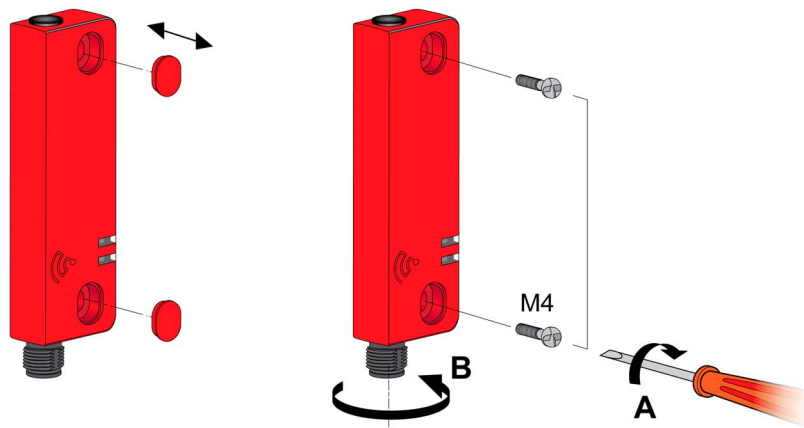

A < 1,5 Nm (13 lb-in)

B < 1 Nm (8.85 lb-in)

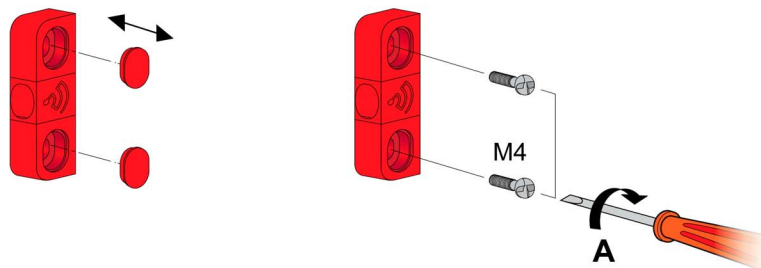

NOTE: To prevent unauthorized removal of the reader and/or the transponder, one-way screws are available as accessory ([see page 73](#)).

Multiple Systems

In case of applications requiring multiple readers which are mounted in close proximity, a minimum distance between readers must be respected to avoid mutual interferences:

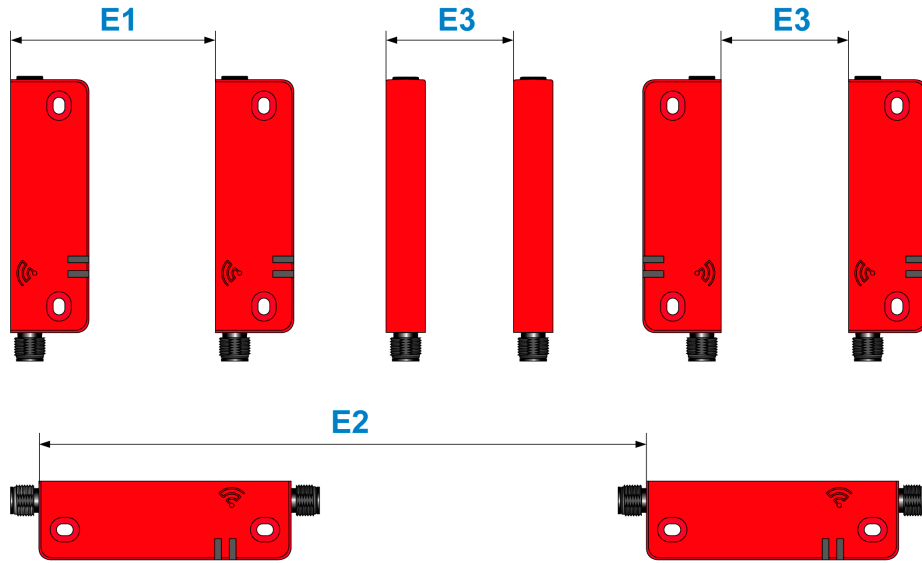

- E1_{min} = 45 mm / 1.77 in
- E2_{min} = 150 mm / 5.91 in
- E3_{min} = 35 mm / 1.38 in

Functional Directions

Different allowed approach directions and associated detection curves are given below.

⚠ WARNING

UNINTENDED EQUIPMENT OPERATION

- Typical switch-on and switch-off values are given for information only, and with a non-magnetic material support for the transponder and the reader.
- These typical values may vary depending on the support materials used.
- The XCSR RFID Safety Switch must always be mounted and used with respect to the assured sensing distances S_{ao} and S_{ar} .
 - When the guard is closed, the maximum distance between the transponder and the reader must be S_{ao}
 - When the guard is being opened and up to S_{ar} , the protected machinery shall not present any risk of danger.

Failure to follow these instructions can result in death, serious injury, or equipment damage.

⚠ WARNING

UNINTENDED EQUIPMENT OPERATION

At every power-up phase, an automatic tuning between the transponder and the reader is performed. The aim of this automatic tuning is to reduce the environmental effects on the sensing distances (e.g. material of the mounting support, room temperature)

Thus, transponder and reader must be installed in their definitive operational conditions before operating the power-up.

Failure to follow these instructions can result in death, serious injury, or equipment damage.

Functional Direction FD1 (“Face to Face” Mounting): PREFERRED CONFIGURATION

Thanks to its rotative (two positions) sensing head, the transponder sensing area can remain “face to face” with the reader sensing area allowing to keep optimized detection conditions. Even in case of different transponder mounting axes, the transponder and reader sensing areas can stay on the same axis:

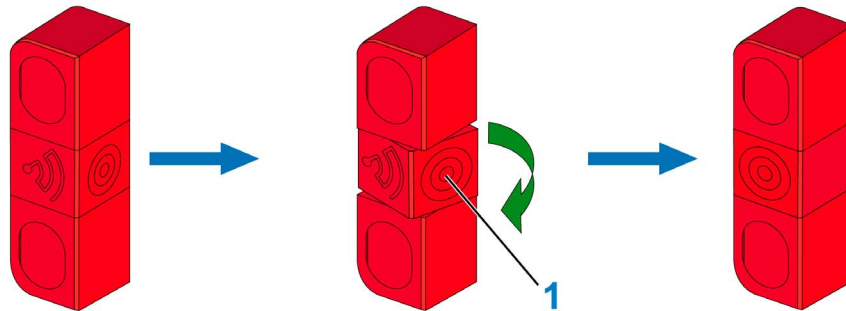

1 Transponder sensing area

In these configurations, transponder and reader sensing areas are “face to face”:

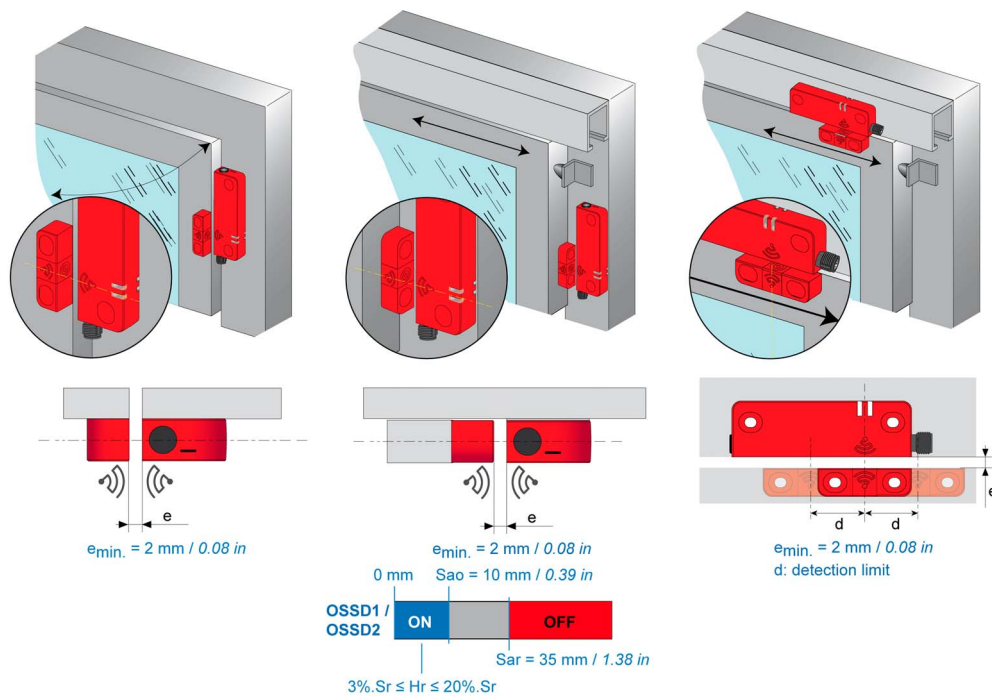

S_{a0} , S_{ar} , H_r values above are given without misalignment between the transponder and the reader ($x=y=z=0$)

NOTICE

UNINTENDED EQUIPMENT OPERATION

Do not use the XCSR reader as a mechanical stop for the mobile part of the safeguard.

Failure to follow these instructions can result in equipment damage.

Detection Curves for “Face to Face” Mounting: PREFERRED CONFIGURATION

Figure of S_{a0} and S_{ar} sensing distances along Y axis as function of Z (longitudinal misalignment for $X=0$) Figure of S_{a0} and S_{ar} sensing distances along X axis as function of Z (transverse misalignment for $Y=0$)

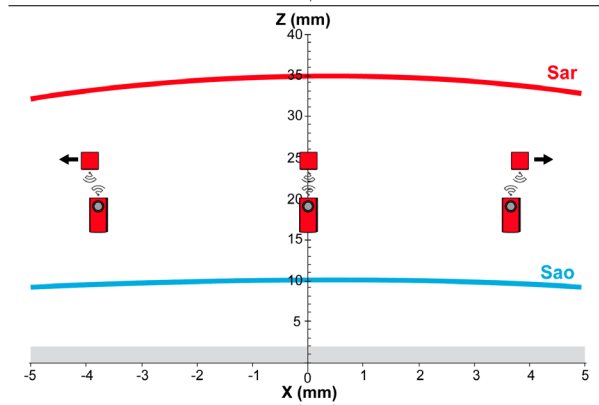
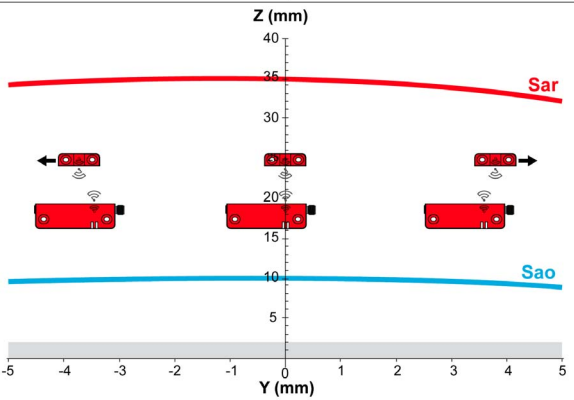
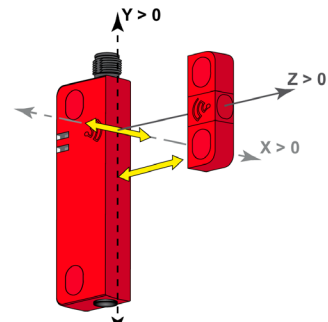
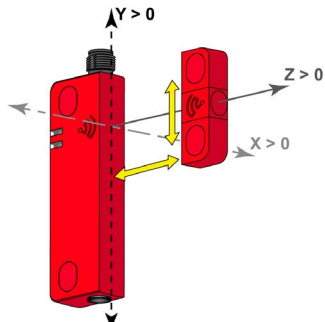

Typical switch-on and switch-off sensing distances along Y axis as function of Z.
(longitudinal misalignment for X=0)

Typical switch-on and switch-off sensing distances along X axis as function of Z.
(transverse misalignment for Y=0)

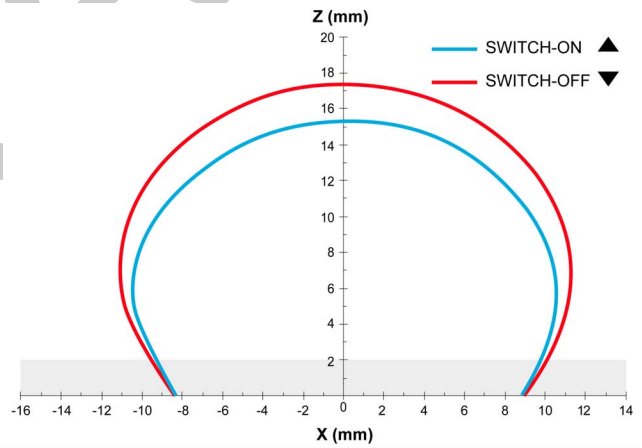
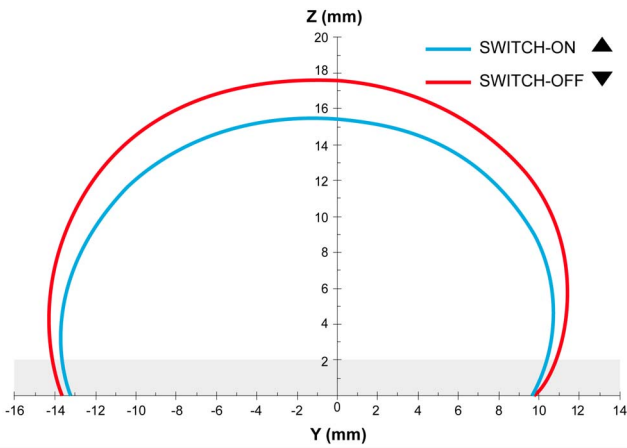

Functional Direction FD2 (“Side by Side” Mounting)

In this configuration, transponder and reader sensing areas are “side by side”:

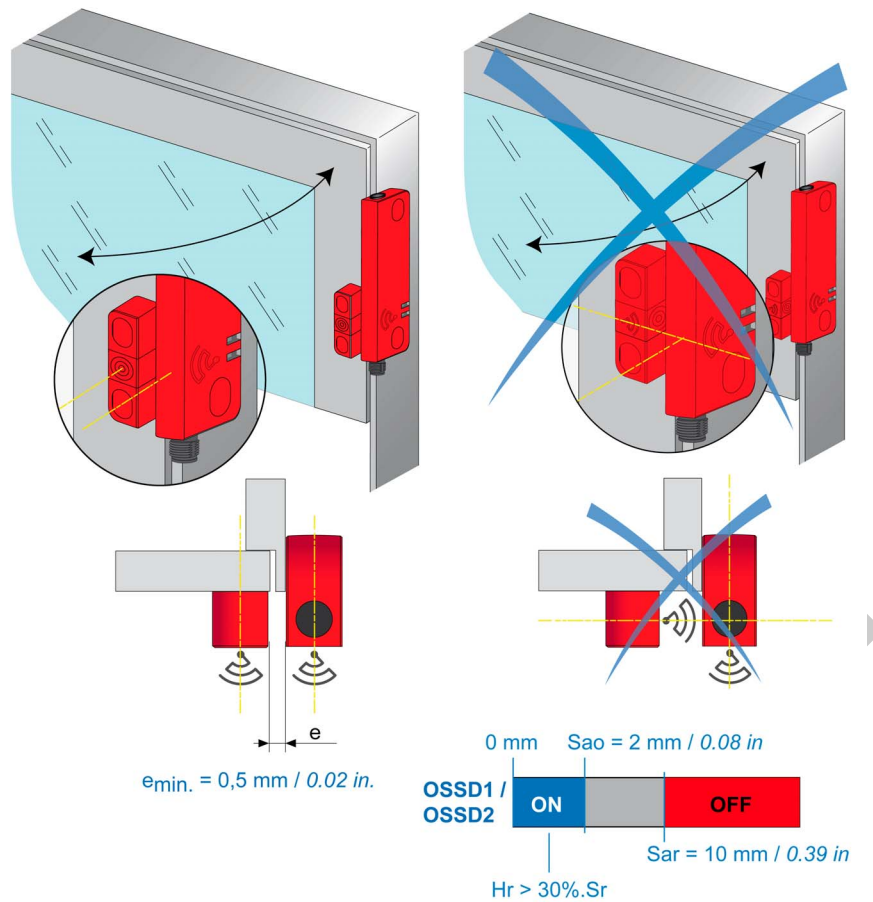

S_{ao} , S_{ar} , H_r values above are given without misalignment between the transponder and the reader ($x=y=z=0$)

NOTICE
UNINTENDED EQUIPMENT OPERATION
Do not use the XCSR reader as a mechanical stop for the mobile part of the safeguard.
Failure to follow these instructions can result in equipment damage.

Detection Curves for “Side by Side” Mounting

Figure of S_{ao} and S_{ar} sensing distances along Y axis as function of X (longitudinal misalignment for Z=0) Figure of S_{ao} and S_{ar} sensing distances along Z axis as function of X (transverse misalignment for Y=0)

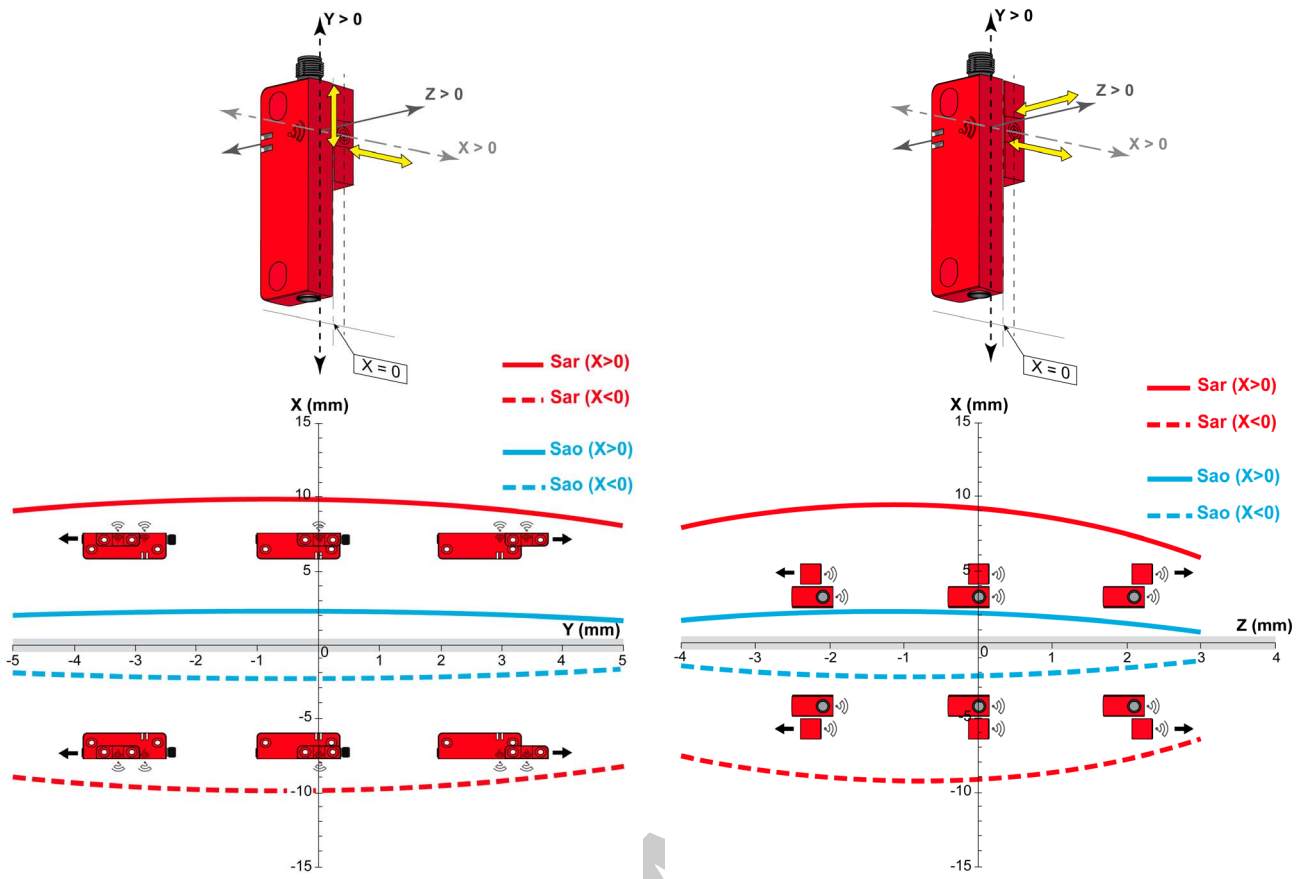

DRAFT

Chapter 4

Wiring

Overview

WARNING

IMPROPER CONNECTION

- The XCSR RFID Safety Switches must be powered by a safety extra low voltage (SELV) or a protected extra low voltage (PELV).
- The XCSR RFID Safety Switches are designed for use only on a 24 Vdc negative ground electrical system.
- Never connect the XCSR RFID Safety Switches to a positive ground system.

Failure to follow these instructions can result in death, serious injury, or equipment damage.

The XCSR RFID Safety Switches operate directly from a 24 Vdc power supply. The power supply must meet the requirements of IEC 60204-1. The SELV Schneider Electric part number ABL8RPS24... is recommended. For more information, refer to Power Supply ([see page 73](#)).

WARNING

IMPROPER CONNECTION

- The XCSR RFID Safety Switches must be connected using both safety outputs.
- A single safety output, if it fails, may not stop the machine.

Failure to follow these instructions can result in death, serious injury, or equipment damage.

What Is in This Chapter?

This chapter contains the following topics:

Topic	Page
Electrical Connections	52
Connection Schematics	56

Electrical Connections

Single Connections (XCSRC•0M12)

This table describes the pin-wire connections for the M12, 5-pin connector of single models:

M12, 5-pin (XCSRC•0M12)		
Pin number	Description	Connector
1	+24 Vdc	
2	OSSD2	
3	0 Vdc	
4	OSSD1	
5	Not connected	

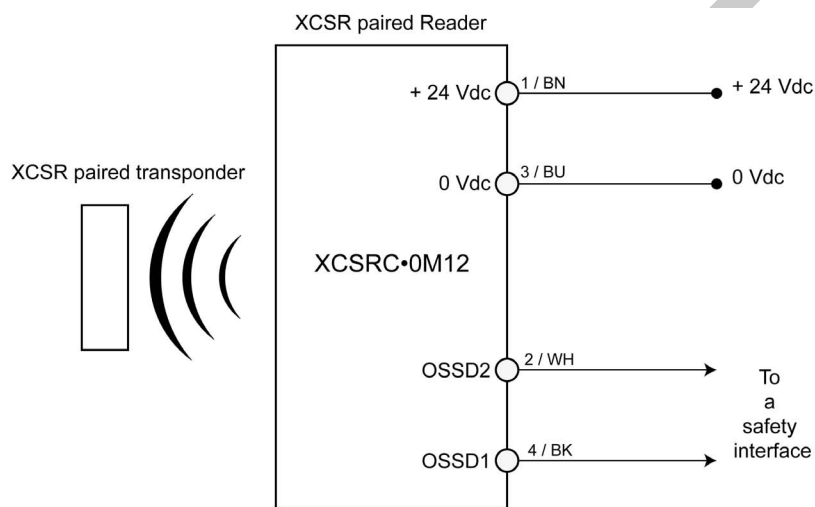

Refer to Cable References XZCP11V12L•• or XZCP12V12L•• (see page 74).

Series Connections (XCSRC•2M12)

This figure describes the connections of daisy-chain models:

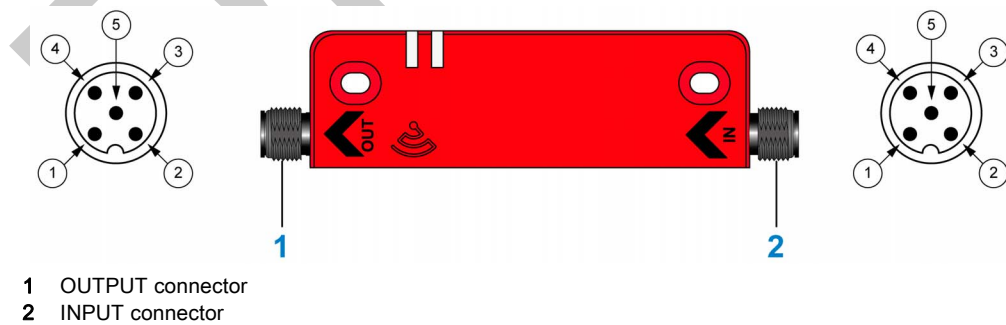

This table describes the pin-wire connections for the M12, 5-pin connectors of daisy-chain models:

M12, 5-pin (XCSRС•2M12)			
Pin number	Description		Connector
	OUTPUT connector	INPUT connector	
1	+24 Vdc	+24 Vdc	
2	OSSD2 (O2)	INPUT2 (I2)	
3	0 Vdc	0 Vdc	
4	OSSD1 (O1)	INPUT1 (I1)	
5	Diagnosis Out (Do)	Diagnosis In (Di)	

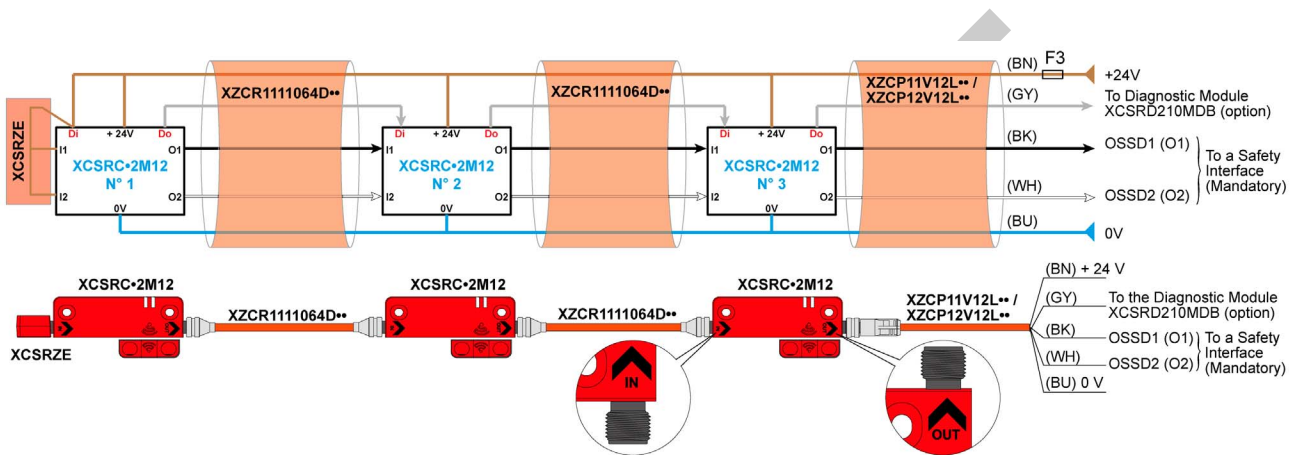

BN Brown
 WH White
 BU Blue
 BK Black
 GY Grey

Refer to Cable References XZCP11V12L**, XZCP12V12L**, or XZCR1111064D** (see page 74).

Considering only the electrical aspect, the maximum number of readers that can be connected in series depends on different factors: the cable length between each XCSR reader, the output current, the input voltage, and the wire cross section.

NOTE: The maximum number of XCSRС•2M12 that can be connected in series is limited to 20 and the maximum distance between 2 switches is 30 m (98.4 ft.).

In the following assumptions:

- Voltage supply 24 Vdc
- Wire cross-section 0.34 mm² (AWG 22)
- Output current 200 mA for each output of the last switch (connected to the safety interface)

Up to 5 switches connected in series, the maximum length between each switch is 30 m (98.4 ft.).

For higher numbers of switches, the maximum cable length allowed between each switch decreases. For example, for **10 switches** connected in series, the maximum length between each switch is **10 m (32.8 ft.)**.

Standalone Connections (XCSRC•1•M12)

This table describes the pin-wire connections for the M12, 8-Pin connector of standalone models:

M12, 8-pin (XCSRC•1•M12)		
Pin number	Description	Connector
1	+24 Vdc	
2	OSSD2	
3	0 Vdc	
4	OSSD1	
5	EDM_ST_1	
6	EDM_ST_2	
7	Not connected	
8	Not connected	

Refer to Cable References XZCP29P12L•• or XZCP53P12L•• (see page 74).

Monitored manual start models XCSRC•1MM12:

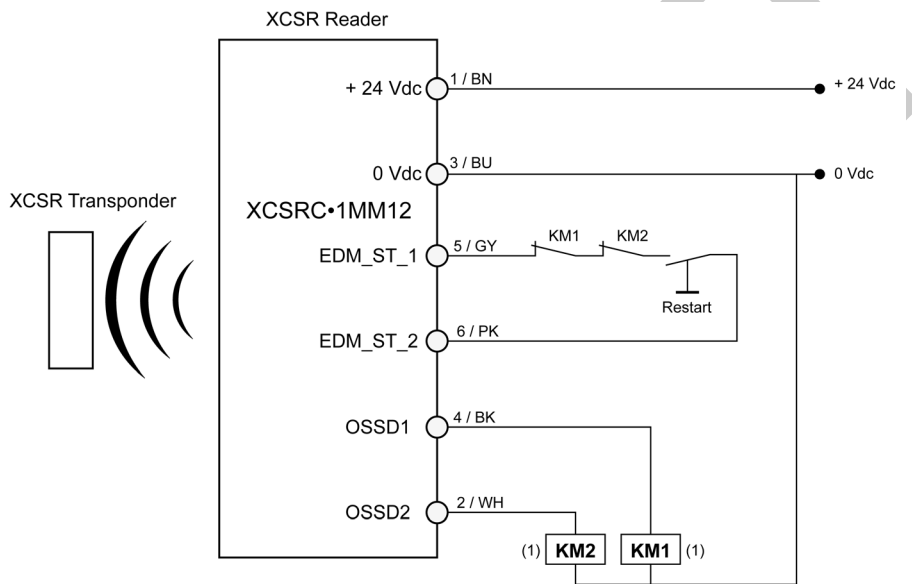

Automatic start/restart models XCSRC•1AM12:

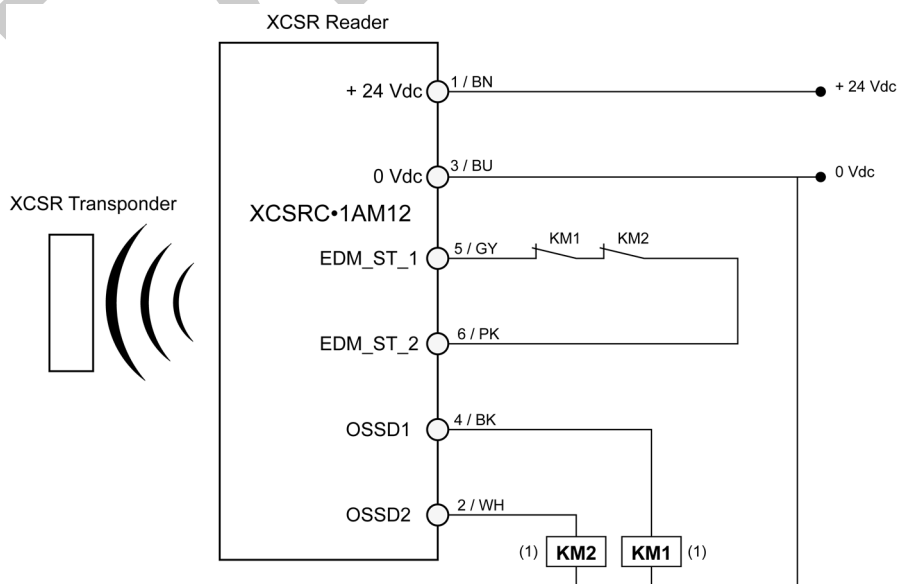

(1) Use of arc suppressors for KM1 & KM2 is recommended.

⚠ WARNING**UNINTENDED EQUIPMENT OPERATION**

The KM1 and KM2 contactors must have force-guided contacts.

Failure to follow these instructions can result in death, serious injury, or equipment damage.

NOTE: XCSR•1AM12 models can also be used with not monitored manual start/restart by adding a push button in series in the EDM loop. In this configuration, the start command is effective when the command is pressed only (0 Vdc -> 24 Vdc).

⚠ WARNING**UNINTENDED EQUIPMENT OPERATION**

When configured with not monitored manual start/restart, the system cannot differentiate the press action from a short-circuit. In case of intentional (or not) short circuit of the start command, the system would be permanently reset (as for automatic start configuration). If a manual start is required, the use of monitored start command is strongly recommended (use of XCSRC•1MM12 models).

Failure to follow these instructions can result in death, serious injury, or equipment damage.

DRAFT

Connection Schematics

Standalone Application

The XCSRC•1•M12 standalone models can be directly connected to contactors having mechanically linked contacts (force-guided) connected to the OSSDs. In that configuration, the use of a safety relay, controller, or PLC is not compulsory.

This figure describes the wiring diagram for XCSRC•1MM12 standalone with monitored manual start and contactor contacts feedback loop (EDM):

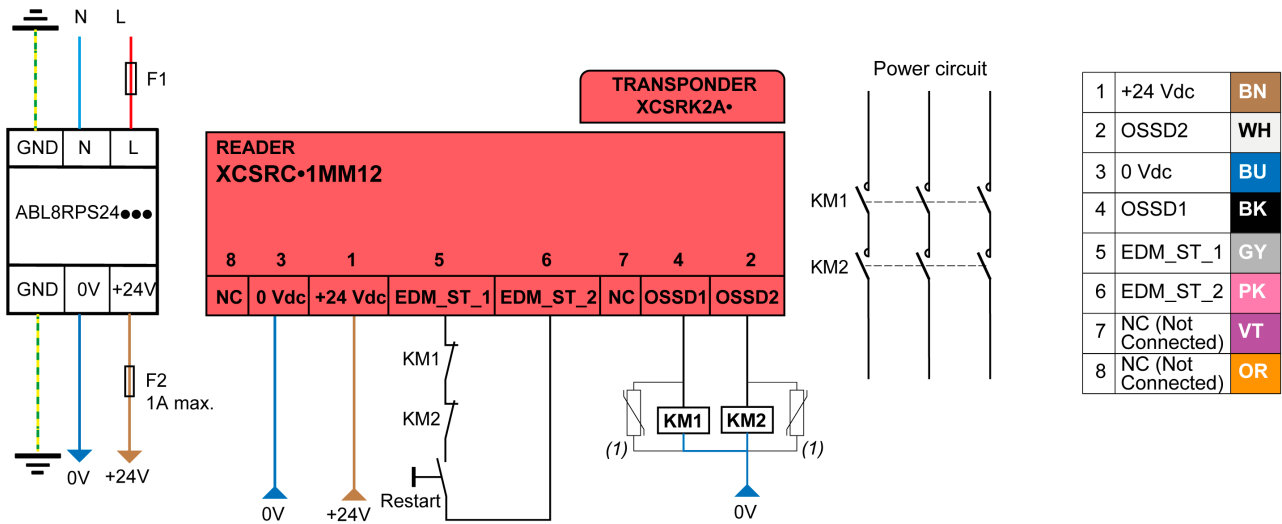

(1) Use of arc suppressors for KM1 & KM2 is recommended.

(2) 1 A maximum

BN Brown

WH White

BU Blue

BK Black

GY Grey

PK Pink

VT Purple

OR Orange

BK/WH Black / White

GN/YE Green / Yellow

Refer to Cable References XZCP29P12L•• or XZCP53P12L•• (see page 74).

XCSRC•1•M12 standalone models are compliant with the following standards:

- SIL3 (IEC 61508) SILCL3 (IEC 62061), and PLe- Cat.4 (EN ISO 13849-1)

NOTICE

UNINTENDED EQUIPMENT OPERATION

- The maximum cable length for EDM/restart feedback loop and OSSD connections is 30 m (98.42 ft.)
- Use of arc suppressors ⁽¹⁾ for KM1 & KM2 is recommended.

Failure to follow these instructions can result in equipment damage.

⚠ WARNING

UNINTENDED EQUIPMENT OPERATION

The KM1 and KM2 contactors must have force-guided contacts.

Failure to follow these instructions can result in death, serious injury, or equipment damage.

⚠ WARNING

IMPROPER TYPE UTILIZATION

It is the responsibility of the user or integrator to check whether the use of standalone XCSR RFID Safety Switch is consistent with the application risk assessment.

Perform a risk assessment to choose the right product for your application.

Failure to follow these instructions can result in death, serious injury, or equipment damage.

When Do We Use Safety Relays, Controllers or Safety PLCs?

The level of a complete safety system can decrease as the number of safety sensors or functions used increases. The use of safety interfaces like safety controllers or safety PLC can be helpful for keeping the overall system at the right safety integrity level.

Safety interface can also be justified when additional features are required by the application. The choice between the different ranges of safety interfaces depends on the number of safety functions and the number of safety sensors used in the application.

This graph is a simplified representation of the common uses of safety interfaces:

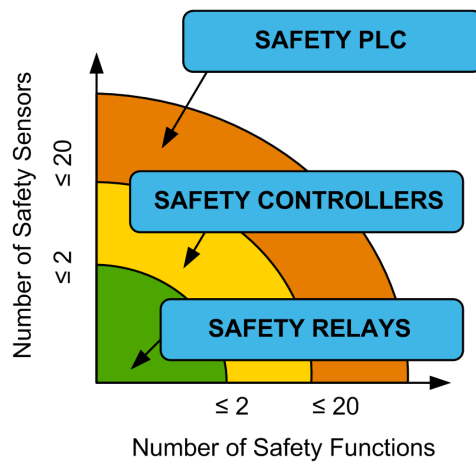

The limit numbers indicated in the graph above are not restrictive and they can vary depending on the applications.

This table describes different interests of using the Schneider-Electric Preventa safety interfaces:

Safety interface - Features of interest	Safety relay				Controller ⁽¹⁾		Safety PLC
	XPSAFL	XPSAK	XPSAR	TM3SAK	XPSMC	XPSMCM	SLC
Maximum reachable safety integrity level ⁽²⁾	PLe, SIL 3	PLe, SIL 3	PLe, SIL 3	PLe, SIL 3	PLe, SIL 3	PLe, SIL 3	PLe, SIL 3
Increase the number of safety outputs ⁽⁴⁾	Yes	Yes	Yes	Yes	Yes	Yes	Yes
Potential free contacts	3 outputs	3 outputs	6 outputs	6 outputs	2 x 2 outputs	Modular (see XPSMCMER modules)	Up to 160 ⁽³⁾
Potential free contact time delayed	-	-	-	-	2 x 2 outputs	Yes, programmable	Up to 160 ⁽³⁾

- 1 See the features of the XPSMC and XPSMCM safety controllers.
- 2 According to EN ISO 13849 (PL) and EN/IEC 62061 (SIL).
- 3 Maximum configuration contains 80 I/O-slices. Input slices contain maximum 4 inputs, solid-state outputs contain maximum 4 outputs, and relay outputs contain maximum 2 outputs.
- 4 Use of potential-free safety outputs can also be useful to increase the output current and drive external devices (for example, contactors) with voltages different from 24 Vdc. Refer to the safety interfaces features.
- 5 Use of XPSMC or safety PLC static outputs can also be useful to increase the output current. Refer to the safety interfaces features.

Safety interface - Features of interest	Safety relay				Controller ⁽¹⁾		Safety PLC
	XPSAFL	XPSAK	XPSAR	TM3SAK	XPSMC	XPSMCM	SLC
Static outputs for PLC diagnosis	–	Yes	Yes	Embedded	(Through different communication protocols)	Modular, up to 26	Embedded
	–	4 outputs	4 outputs				
Increase the number of safety outputs Static outputs ⁽⁵⁾	–	–	–	–	Yes	Modular, up to 16	Yes
	–	–	–	–	6 outputs		Yes
Auxiliary output (for example, PLC input or light indicator)	–	1	2	–	Yes	Yes	Yes
External Device Monitoring (EDM)	Yes	Yes	Yes	Yes	Yes	Yes	Yes
Not monitored manual start	No	Yes	Yes	Yes	Yes	Yes	Yes
Monitored manual start	Yes S33–S34	Yes	Yes	Yes	Yes	Yes	Yes
Automatic start	No	Yes	Yes	Yes	Yes	Yes	Yes
Low number of Safety sensors / Safety functions	Yes	Yes	Yes	Yes	Yes	Yes	–
Medium number of Safety sensors / Safety functions	–	–	–	–	Yes	Yes	–
High number of Safety sensors / Safety functions	–	–	–	–	–	Yes	Yes

1 See the features of the XPSMC and XPSMCM safety controllers.
2 According to EN ISO 13849 (PL) and EN/IEC 62061 (SIL).
3 Maximum configuration contains 80 I/O-slices. Input slices contain maximum 4 inputs, solid-state outputs contain maximum 4 outputs, and relay outputs contain maximum 2 outputs.
4 Use of potential-free safety outputs can also be useful to increase the output current and drive external devices (for example, contactors) with voltages different from 24 Vdc. Refer to the safety interfaces features.
5 Use of XPSMC or safety PLC static outputs can also be useful to increase the output current. Refer to the safety interfaces features.

Connecting to a Safety Monitoring Device

The wiring from the XCSR RFID Safety Switch to the machine control circuit must be control reliable. The solid-state outputs should be connected only to a control reliable, safety-rated PLC or to a control reliable safety-rated machine system.

Connecting with an XPSAK Module

This figure describes the connection of single model XCSRC•0M12 with an XPSAK module, with EDM and manual start with monitoring of the start button:

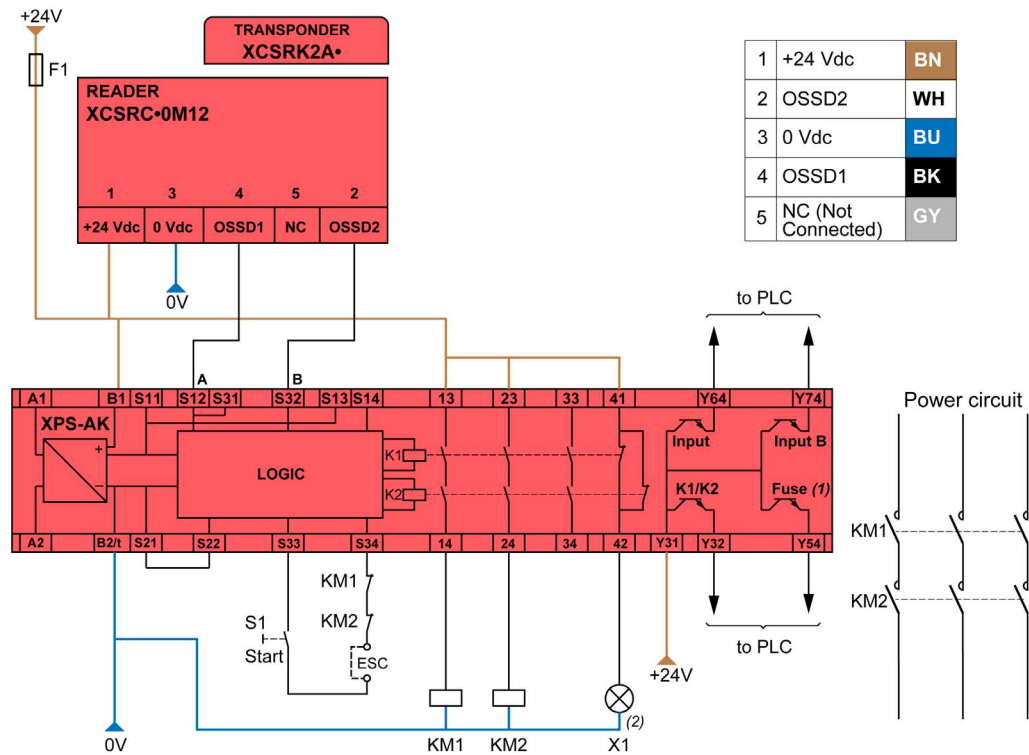

- (1) Operating status of internal electronic fuse
- (2) XCSR RFID Safety Switch indicator light deactivated
- ESC External Start Conditions
- BN Brown
- WH White
- BU Blue
- BK Black
- GY Grey

Refer to Cable References XZCP11V12L•• or XZCP12V12L•• (see page 74).

Automatic start is possible by removing the start button in the schematic above (short circuit instead) and by connecting directly S13 to S14 (electrical jumper between S13 and S14).

NOTICE

UNINTENDED EQUIPMENT OPERATION

The maximum cable length for EDM/restart feedback loop and OSSD connections is 30 m (98.42 ft.).

Failure to follow these instructions can result in equipment damage.

⚠ WARNING

UNINTENDED EQUIPMENT OPERATION

The KM1 and KM2 contactors must have force-guided contacts.

Failure to follow these instructions can result in death, serious injury, or equipment damage.

Connecting with an XPSAFL Module

This figure describes the series connection of five XCSRC-2M12 daisy-chain models with an XPSAFL module, with EDM and monitored manual start:

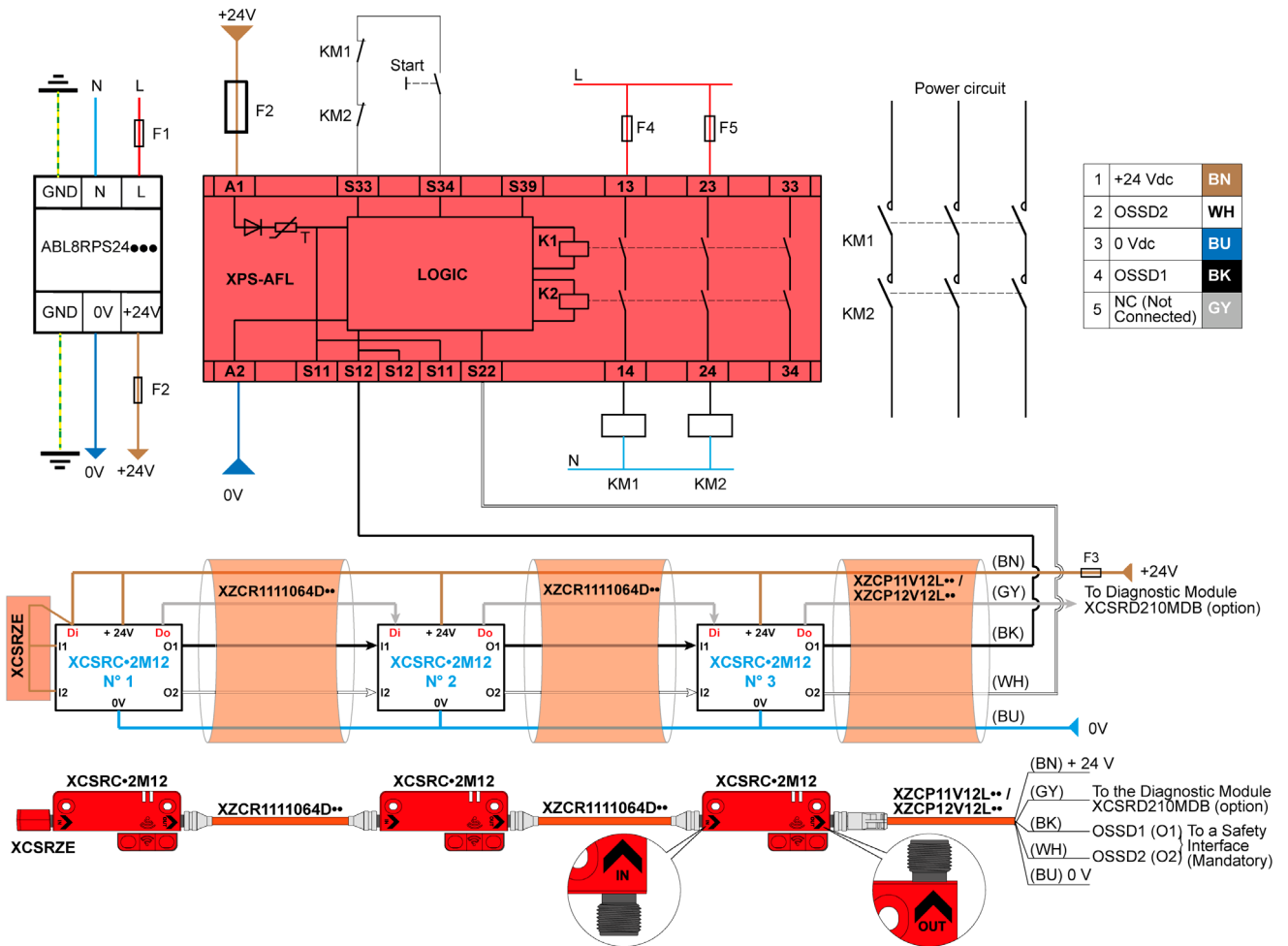

- BN Brown
- WH White
- BU Blue
- BK Black
- GY Grey

Refer to Cable References XZCP11V12L.. or XZCP12V12L.. (see page 74).

NOTICE

UNINTENDED EQUIPMENT OPERATION

The maximum cable length for EDM/restart feedback loop and OSSD connections is 30 m (98.42 ft.).
Failure to follow these instructions can result in equipment damage.

⚠ WARNING

UNINTENDED EQUIPMENT OPERATION

The KM1 and KM2 contactors must have force-guided contacts.
Failure to follow these instructions can result in death, serious injury, or equipment damage.

Connecting with a XPSMC Controller

This figure describes the example of wiring diagram of a XCSRC•0M12 single model with the XPSMC safety controller:

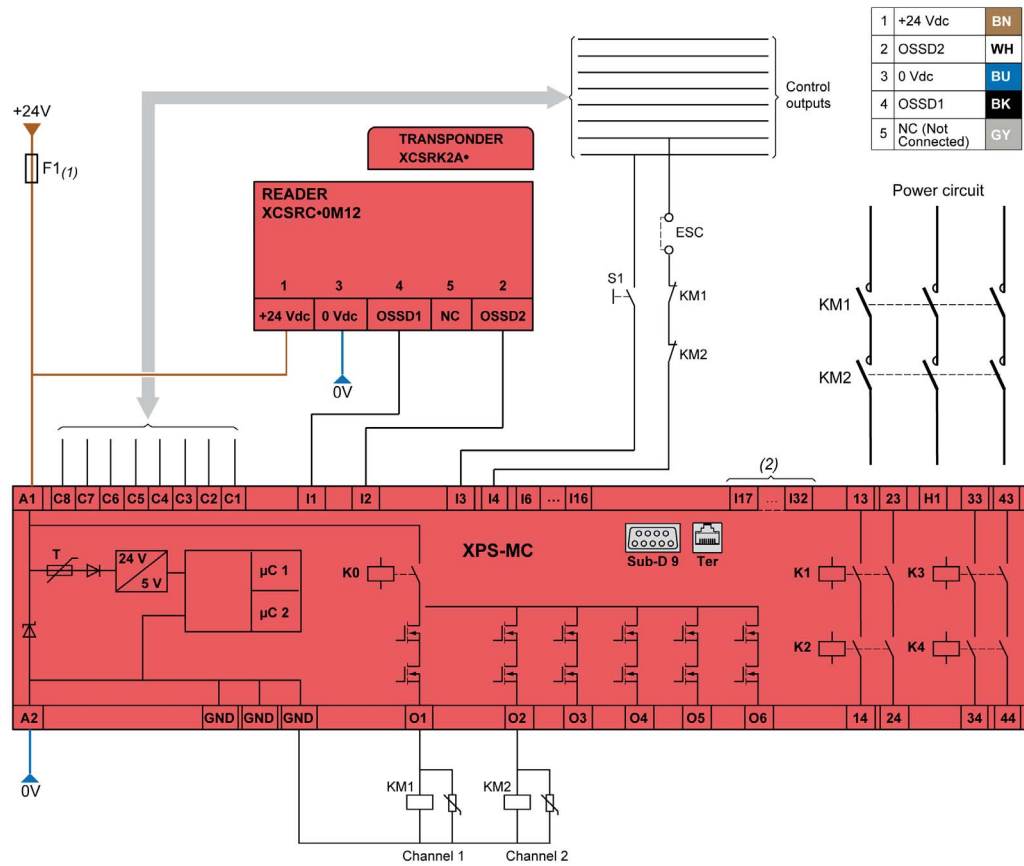

- ESC** External start conditions
- OSSD1/OSSD2** Output signal switching device
- 1** Technical characteristics for minimum rating of fuse. Refer to XPSMC catalog (technical data).
- 2** Only applicable to XPSMC32Z...
- BN** Brown
- WH** White
- BU** Blue
- BK** Black
- GY** Grey

Refer to Cable References XZCP11V12L•• or XZCP12V12L•• (see page 74).

NOTICE

UNINTENDED EQUIPMENT OPERATION

The maximum cable length for EDM/restart feedback loop and OSSD connections is 30 m (98.42 ft.).
Failure to follow these instructions can result in equipment damage.

⚠ WARNING

UNINTENDED EQUIPMENT OPERATION

The KM1 and KM2 contactors must have force-guided contacts.
Failure to follow these instructions can result in death, serious injury, or equipment damage.

Connecting with an XPSMCM Controller

This figure describes the connection of a XCSRC•0M12 single model with an XPSMCM controller:

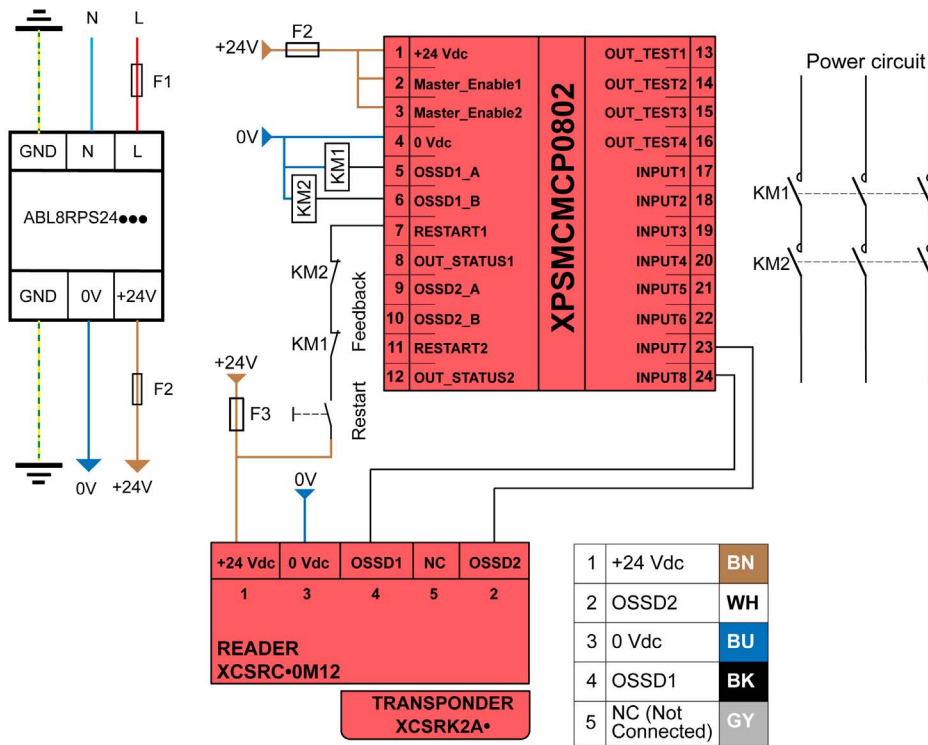

- BN Brown
- WH White
- BU Blue
- BK Black
- GY Grey

Refer to Cable References XZCP11V12L•• or XZCP12V12L•• (see page 74).

NOTICE

UNINTENDED EQUIPMENT OPERATION

The maximum cable length for EDM/restart feedback loop and OSSD connections is 30 m (98.42 ft.).
Failure to follow these instructions can result in equipment damage.

⚠ WARNING

UNINTENDED EQUIPMENT OPERATION

The KM1 and KM2 contactors must have force-guided contacts.
Failure to follow these instructions can result in death, serious injury, or equipment damage.

Part III
Technical Characteristics

DRAFT

DRAFT

Chapter 5

Technical Characteristics

Overview

This chapter describes the technical characteristics of the XCSR RFID Safety Switch.

What Is in This Chapter?

This chapter contains the following topics:

Topic	Page
XCSR RFID Safety Switch Specifications	66
Safety Related Data	69
Dimensions	70
Accessories	73

DRAFT

XCSR RFID Safety Switch Specifications

Conformity/Approvals

This table provides the standards and approvals:

Conforming to standards	ISO 14119:2013, EN/IEC 60947-5-2, EN/IEC 60947-5-3, EN/ETSI 301 489-1, EN/ETSI 300 330 UL 508, CSA C22.2, CFR 47 FCC 15, RSS GEN, RSS 210 SIL 3 (IEC 61508), SILCL 3 (IEC 62061), PLe-Cat.4 (EN ISO 13849-1)
Approvals	CE, cULus (The safety function of this device has not been evaluated by UL), TÜV, FCC, EAC, IC, RCM, E2

Environmental Specifications

This table provides the environmental specifications:

Environmental characteristics		Description
Ambient air temperature	For operation	-25...+70 °C (-13...+158 °F) Humidity < 95% - without condensation
	For storage	-40...+85 °C (-40...+185 °F) Humidity < 95% - without condensation
Degree of protection	Connector models	IP65, IP66, and IP67 conforming with EN/IEC 60529 IP69K conforming with DIN 40050 Enclosure type 4
Resistance to shocks and vibrations	–	In accordance with EN/IEC 60947-5-3: <ul style="list-style-type: none"> ● Shocks, conforming with EN/IEC 60068-2-27: 30 gn (impulse duration 11 ms) ● Vibration, conforming with EN/IEC 60068-2-6: 10 gn (10...150 Hz)
Materials	–	Housing: Valox Red color: RAL 3000
Environmental chemicals		
Chemical resistance	Aliphatic hydrocarbons	Resistant
	Alcohols	
	Detergents and cleansers	
	Detergents and cleansers containing alkali products	
	Alkaline (non-chlorinated) cleaning agents	
	Acid cleaning agents	
	Aliphatic hydrocarbons	
Environmental resistance	Humidity	Resistant
	Weathering (sun, water)	

Characteristic Times

This table provides the characteristic times:

Characteristic times	Unit	Value	Description
Response time	ms	Typical $T_t = 120$ ms (+ 50 ms per additional switch in Daisy-Chain configuration) $T_t = 250$ ms for standalone models	Refer to Definition of Characteristic Times (see page 18).
Risk time	ms	$T_r < 120$ ms (+ 18 ms per additional switch in Daisy-Chain configuration)	
First-up time	s	$T_{ON} < 5$ s	
Pairing mode time	s	$T_{PM} = 10$ s	
Safety inputs inconsistency time	ms	$T_{IT} < 18$ ms	
OSSDs delay time	ms	$T_{DT} < 18$ ms	
OSSDs pulse width	ms	$T_{PT} = 1.4$ ms maximum under 24 Vdc with maximum load capacitance 40 nF	
OSSDs pulse Duty Cycle	ms	300 ms maximum	
Switching frequency	Hz	0.5 Hz maximum	

Typical Operating Distances (Face to Face Mounting)

This table provides the typical operating distances:

Characteristic times	Unit	Value	Description
Typical operating sensing distance	mm	15 mm (*) (0.59 in)	FD1 Functional Direction along longitudinal axis (see page 45)
Assured operating sensing distance (S_{ao})	mm	$S_{ao} = 10$ mm (0.39 in)	
Typical release sensing distance	mm	18 mm (*) (0.71 in)	
Assured release sensing distance (S_{ar})	mm	$S_{ar} = 35$ mm(1.38 in)	
Repeat accuracy	–	$\leq 10\% \times S_r$	
Typical hysteresis	–	$3\% \times S_r \leq H \leq 20\% \times S_r$	

(*) Ambient temperature, on non-magnetic support, without misalignment between the transponder and the reader.

Electrical Characteristics

The given table provides the electrical characteristics:

Electrical characteristics	Unit	Description
Power supply	V	24 Vdc -20% +10% The power supply must meet requirements of IEC 60204-1 relative to SELV/PELV power supply.
Maximum current consumption (no load)	mA	60 mA
EMC immunity withstands	–	Conforming EN/IEC 60947-5-3, EN/IEC 61326-3-1, and EN/ETSI 301 489-1
Safety outputs (OSSD)	–	Two OSSDs PNP: <ul style="list-style-type: none"> • Standalone XCSRC•1•M12: Maximum 400 mA per output at 24 Vdc Drop out voltage < 2 Vdc Leakage current (OFF state) < 1 mA Maximum load inductance xxx mH under 24 Vdc Maximum load capacitance 40 nF under 24 Vdc Switching capacity: DC12 & DC13: $U_e = 24$ Vdc - $I_e = 400$ mA • Single and daisy-chain XCSRC•0M12 and XCSRC•2M12: Maximum 200 mA per output at 24 Vdc Drop out voltage < 2 Vdc Leakage current (OFF state) < 1 mA. Maximum load capacitance 40 nF under 24 Vdc Switching capacity: DC12: $U_e = 24$ Vdc - $I_e = 200$ mA DC12: Resistive load (all versions) DC13: Inductive load (standalone versions) Short Circuit protection conforming to EN/IEC 60947-5-3
Safety-related inputs	–	Two DC digital positive inputs Maximum load capacitance 10 nF under 24 Vdc 24 Vdc -20% +10% Current consumption < 5 mA
Maximum XCSR RFID switches connectable in series	–	≤ 20 XCSRC•2M12 (refer to Series Connections (see page 52))
Signals	–	2 three-color LEDs - Red/Green/Orange
Connections	–	Single XCSRC•0M12: 5 pins male M12 connector Standalone XCSRC•1•M12: 8 pins male M12 connector Daisy-chain XCSRC•2M12: 2 x 5 pins male M12 connector Refer to Electrical Connections (see page 52).
Protection against electric shocks	–	Class III as per EN/IEC 61140

Radio-Emission Characteristics

The given table provides the radio-emission characteristics:

Radio-emission characteristics	Unit	Description
Carrier frequency	MHz	13.56 MHz
Operating frequency band	MHz	13.553...13.567 MHz (Sub band j.2 from appendix 9 of ERC/REC 70-03)
Maximum radiated magnetic field	–	-7.77 dB μ A/m at 10 m, according to EN/ETSI 300 330

FCC

NOTE TO USERS IN THE UNITED STATES

This device complies with Part 15 of the FCC Rules. Operation is subject to the following two conditions:

1. This device may not cause harmful interference, and
2. This device must accept any interference received, including interference that may cause undesired operation.

This equipment has been tested and found to comply with the limits for a Class B digital device, pursuant to Part 15 of the FCC Rules. These limits are designed to provide reasonable protection against harmful interference in a residential installation. This equipment generates uses and can radiate radio frequency energy and, if not installed and used in accordance with the instructions, may cause harmful interference to radio communications. However, there is no guarantee that interference will not occur in a particular installation.

If this equipment does cause harmful interference to radio or television reception, which can be determined by turning the equipment off and on, the user is encouraged to try to correct the interference by one of the following measures:

- Reorient or relocate the receiving antenna.
- Increase the separation between the equipment and receiver.
- Connect the equipment into an outlet on a circuit different from that to which the receiver is connected.
- Consult the dealer or an experienced radio/TV technician for help.

This equipment complies with FCC's radiation exposure limits set forth for an uncontrolled environment under the following conditions:

1. This equipment should be installed and operated such that a minimum separation distance of 20 cm (7.87 in.) is maintained between the radiator (antenna) and user's/nearby person's body at all times.
2. This transmitter must not be co-located or operating in conjunction with any other antenna or transmitter.

NO UNAUTHORIZED MODIFICATIONS

CAUTION: This equipment may not be modified, altered, or changed in any way without signed written permission from SCHNEIDER ELECTRIC. Changes or modification not expressly approved by the party responsible for compliance could void the user's authority to operate the equipment and will void the SCHNEIDER ELECTRIC warranty.

NOTE TO USERS IN THE CANADA / NOTE A L'ATTENTION DES UTILISATEURS AU CANADA

This device complies with Industry Canada's licen ce-exempt RSSs. Operation is subject to the following two conditions:

1. This device may not cause harmful interference, and
2. This device must accept any interference received, including interference that may cause undesired operation of the device.

Le présent appareil est conforme aux CNR d'Industrie Canada applicables aux appareils radio exempts de licence. L'exploitation est autorisée aux deux conditions suivantes :

1. *L'appareil ne doit pas produire de brouillage, et*
2. *L'utilisateur de l'appareil doit être prêt à accepter tout brouillage radioélectrique subi, même si le brouillage est susceptible d'en compromettre le fonctionnement.*

Identifiers:

Reference	XCSR
FCC ID	Y7HXCSR
IC	7002C-XCSR

Safety Related Data

General Description

This table provides safety related data for the XCSR RFID Safety Switches:

Mission Time (TM) EN/ISO 13849-1	PFH _D EN/ISO 13949-1 and EN/IEC 62061
20 years	5x10 ⁻¹⁰ Per reader

For safety related data definitions, refer to the Glossary (*see page 94*).

DRAFT

Dimensions

XCSRC•0M12 and XCSRC•1•M12 Dimensions

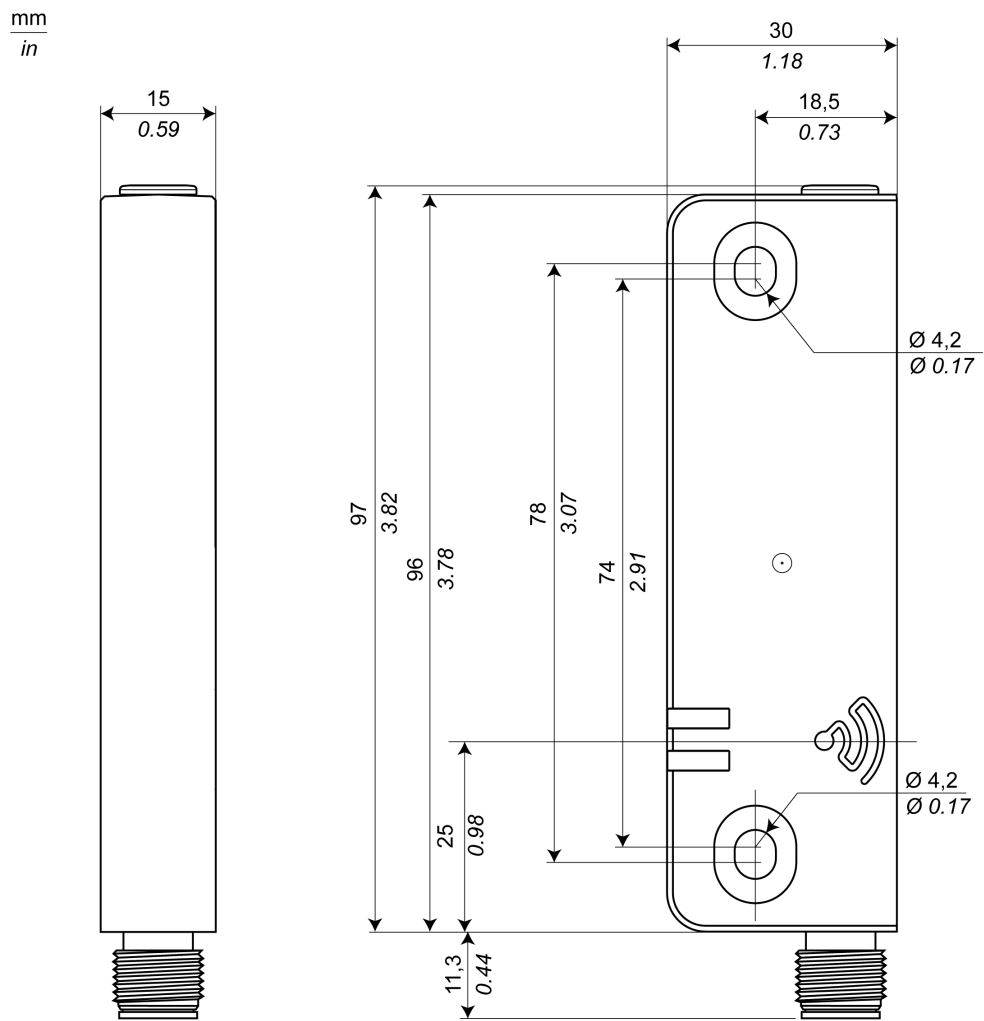

XCSRC-2M12 Dimensions

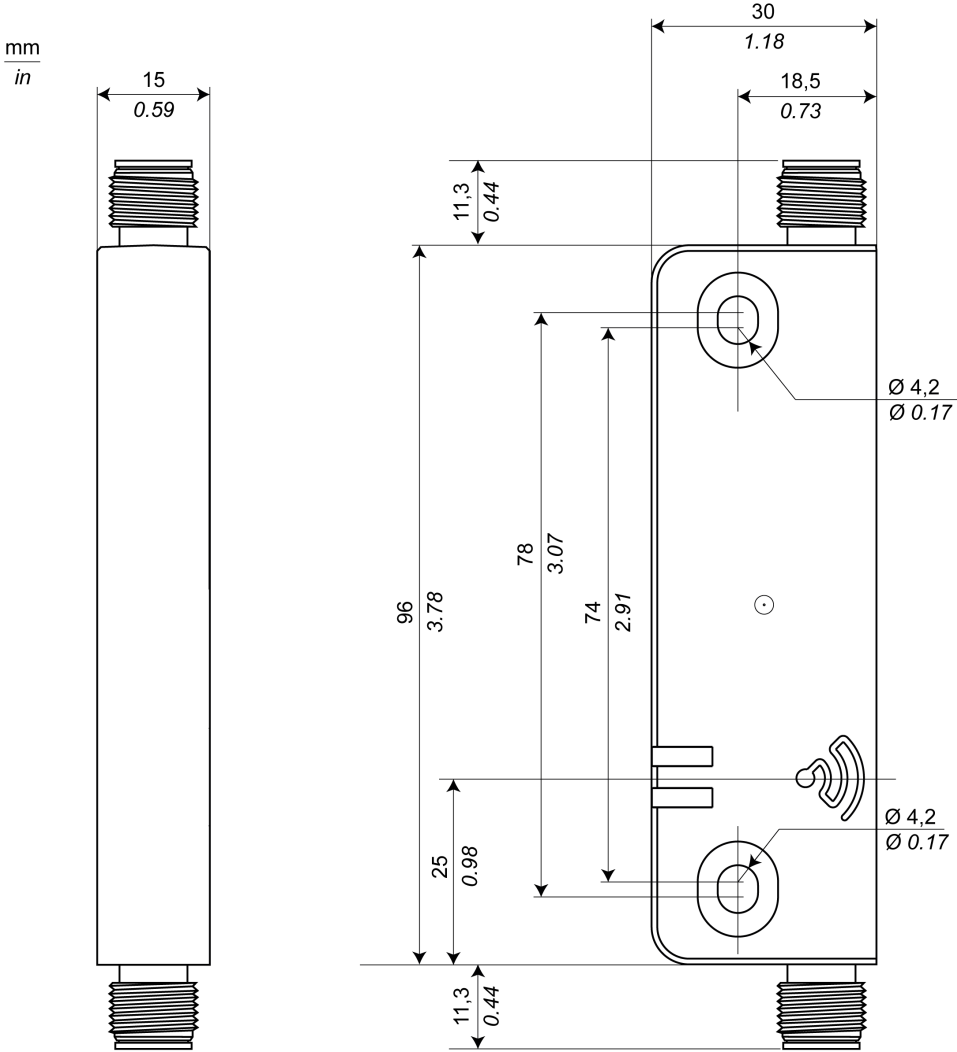

XCSRK2A• Dimensions

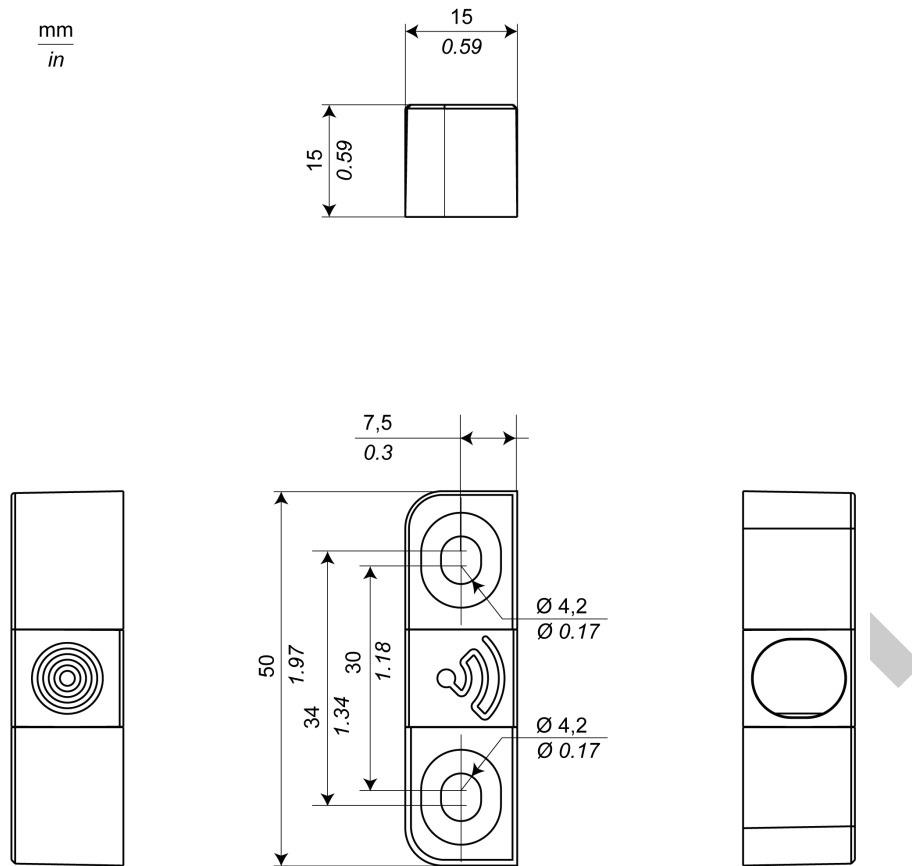

XCSRZE Dimensions

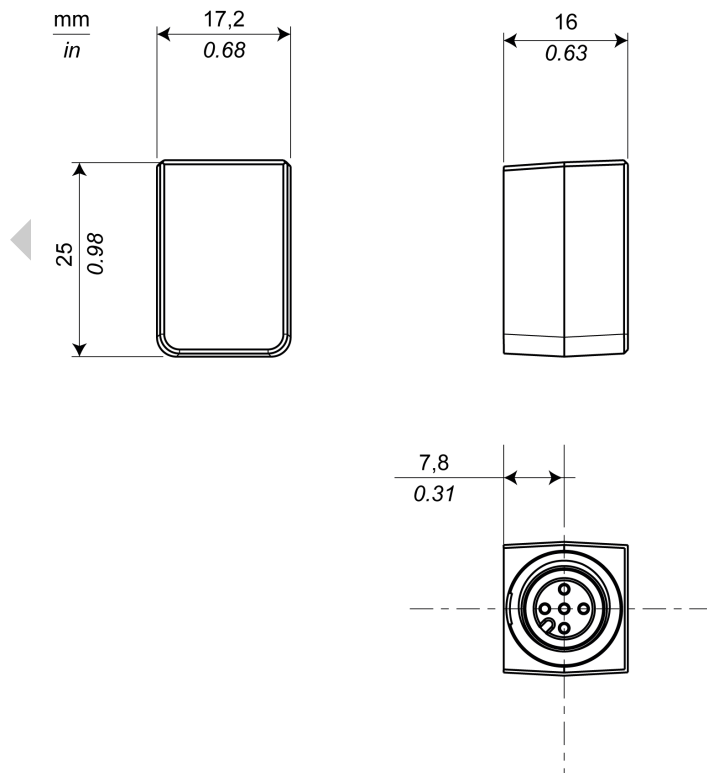

Accessories

Power Supply

The power supply must meet the requirements of IEC 60204-1 and IEC 61496-1. The SELV Schneider Electric part number ABL8RPS24... is recommended.

This figure describes the power supply ABL8RPS24...:

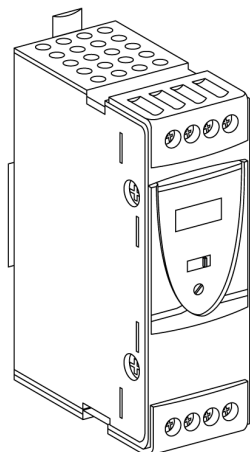

ABL8RPS24... Operating temperature range -25...60 °C without derating:

Input voltage	Secondary			Reset	Conforming to standard EN 61000-3-2	Reference
	Output voltage (V)	Nominal power (W)	Nominal current (A)			
Single to phase (N-L1) 100...120 Vac -15 +10% (50 Hz or 60 Hz)	24...28.8	72	3	Auto/Manual	Yes	ABL8RPS24030
		120	5	Auto/Manual	Yes	ABL8RPS24050
Phase to phase (L1-L2) 200...500 Vac -15 +10% (50 Hz or 60 Hz)		240	10	Auto/Manual	Yes	ABL8RPS24100

Mounting Accessories

This table describes the XCSZ72 one-way screw that should be used to mount the XCSR RFID Safety Switches:

Reference	Description	
XCSZ72	One-way screw, M4x35mm	
XCSZ71	One-way screw, M4x14mm	

Reference	Description	
XCSRZSRC1	Mounting plate for readers XCSRK2A•M12	
XCSRZSTK1	Mounting plate for transponders XCSRK2A•	

Cables

This table describes the 5-pin cables for use with single (XCSRK2A•M12) models and for the connection between a safety interface and the last reader of a daisy-chain (XCSRK2A•2M12):

Cables (pre-wired 5 pins)	Description	Length
XZCP11V12L2	Connector M12 - Female - Straight - 5 poles - PUR - pre-wired 0.34 mm ² (AWG22). Unshielded cable	2 m (6.56 ft)
XZCP11V12L5		5 m (16.4 ft)
XZCP11V12L10		10 m (32.8 ft)
XZCP11V12L20		20 m (65.6 ft)
XZCP12V12L2	Connector M12 - Female - 90° - 5 poles - PUR - pre-wired 0.34 mm ² (AWG22). Unshielded cable	2 m (6.56 ft)
XZCP12V12L5		5 m (16.4 ft)
XZCP12V12L10		10 m (32.8 ft)
XZCP12V12L20		20 m (65.6 ft)
XZCC12FDM50B	Connector M12 - Female - Straight - 5 poles with screw terminals - cable gland - Metal clamping ring	-
XZCC12FCM50B	Connector M12 - Female - 90° - 5 poles with screw terminals - cable gland - Metal clamping ring	-

M12 5-pins connector description:

Pin number	Wire color	Connector
1	Brown	
2	White	
3	Blue	
4	Black	
5	Gray	

This table describes the jumper cables for direct series connection (daisy-chain XCSRC•2M12):

Cables (jumpers 5 pins)	Description	Length
XZCR1111064D03	2 straight M12 - Female/Female - PUR - 5 poles 0.34 mm ² (AWG22). Unshielded cable	0.3 m (0.98 ft)
XZCR1111064D3		3 m (9.84 ft)
XZCR1111064D5		5 m (16.4 ft)
XZCR1111064D10		10 m (32.8 ft)
XZCR1111064D25		25 m (82.02 ft)

This table describes the 8-pin cables for standalone XCSRC•1M12 models:

Cables (pre-wired 8 pins)	Description	Description
XZCP29P12L2	Connector M12 - Female - Straight - 8 poles - PUR - pre-wired 0.34 mm ² (AWG22). Unshielded cable	2 m (6.56 ft)
XZCP29P12L5		5 m (16.4 ft)
XZCP29P12L10		10 m (32.8 ft)
XZCP29P12L20		20 m (65.6 ft)
XZCP53P12L2	Connector M12 - Female - 90° - 8 poles - PUR - pre-wired 0.34 mm ² (AWG22). Unshielded cable	2 m (6.56 ft)
XZCP53P12L5		5 m (16.4 ft)
XZCP53P12L10		10 m (32.8 ft)
XZCP53P12L20		20 m (65.6 ft)
XZCC12FDM80B	Connector M12 - Female - Straight - 8 poles with screw terminals - cable gland - Metal clamping ring	-
XZCC12FCM80B	Connector M12 - Female - 90° - 8 poles with screw terminals - cable gland - Metal clamping ring	-

M12 8-pins connector description:

Pin number	Wire color	Connector
1	Brown	
2	White	
3	Blue	
4	Black	
5	Gray	
6	Pink	
7	Purple	
8	Orange	

DRAFT

Part IV
XCSR210MDB Diagnostic Module

DRAFT

DRAFT

Chapter 6

XCSR210MDB Diagnostic Module

What Is in This Chapter?

This chapter contains the following topics:

Topic	Page
Overview	80
Description	81
Connections Configuration	82
Wiring	84
Diagnostic LED	85
Modbus Registers	86
Operating	90
Characteristics	92

DRAFT

Overview

Overview

WARNING

IMPROPER UTILIZATION

Do not use the Diagnostic module as a safety equipment. Diagnostic function is not part of safety function

Failure to follow these instructions can result in death, serious injury, or equipment damage.

The diagnostic module interprets the diagnostic data of the whole chain, and makes this information available into Modbus registers. Reception of diagnostic data frame is periodic, approximately every 2 s.

Main features of the Diagnostic function:

- The diagnostic function provides the state of all XCSRC•2M12 monitored by the safety chain. It identifies which guards are opened or closed.
- The diagnostic function prevents a new start of the machine if the chain has been tampered, if any XCSRC•2M12 has failed, or in case of wiring disconnection.
- The diagnostic function detects if the loopback device is not connected and prevent a new start until the loopback device is connected and a power cycling has been done.

DRAFT

Description

Product Description

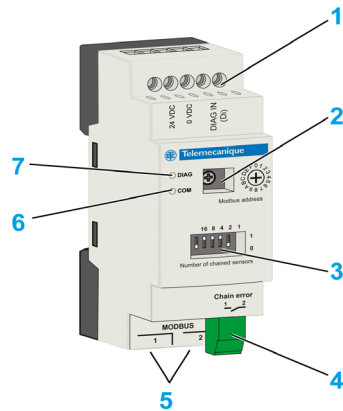

Item	Description	Refer to...
1	Five screw terminals for electrical wiring and the diagnostic signal	Inputs / Power supply Wiring (<i>see page 84</i>)
2	Rotary switch with 16 positions for setting the Modbus address	Operating Hardware Installation (<i>see page 90</i>)
3	Micro-switches for setting the number of XCSR•2M12 connected in series	
4	Plug-in connector for Chain Error potential-free contact (CE/External Start Condition)	CE Wiring (<i>see page 84</i>)
5	Two RJ45 sockets for Modbus communication.	Communication Wiring (<i>see page 84</i>)
6	Modbus LED	Diagnostic LEDs (<i>see page 85</i>)
7	Diagnostic LED	

Connections Configuration

Connections Configuration

The diagnostic module can be used with “daisy chain” XCSRC•2M12 Safety Switches. It must be connected to the end of the chain.

The last XCSRC•2M12 of the chain (end of chain) is the one which is connected to the safety interface (safety relay/controller...).

The first XCSRC•2M12 is the one connected to the loopback device (XCSRZE).

The diagnostic module can monitor up to 20 XCSRC•2M12 connected in series.

NOTE: The use of the diagnostic module is optional, but strongly recommended due to his ability to detect, warn and localize errors on the chain or eventual tampering and thus prevent from machine restart until the chain comes back to a correct operating state.

⚠ WARNING

IMPROPER CONNECTION

The diagnostic module, every XCSRC•2M12, and the safety interface must be powered by the same SELV/PELV power supply.

Failure to follow these instructions can result in death, serious injury, or equipment damage.

Wiring is described below:

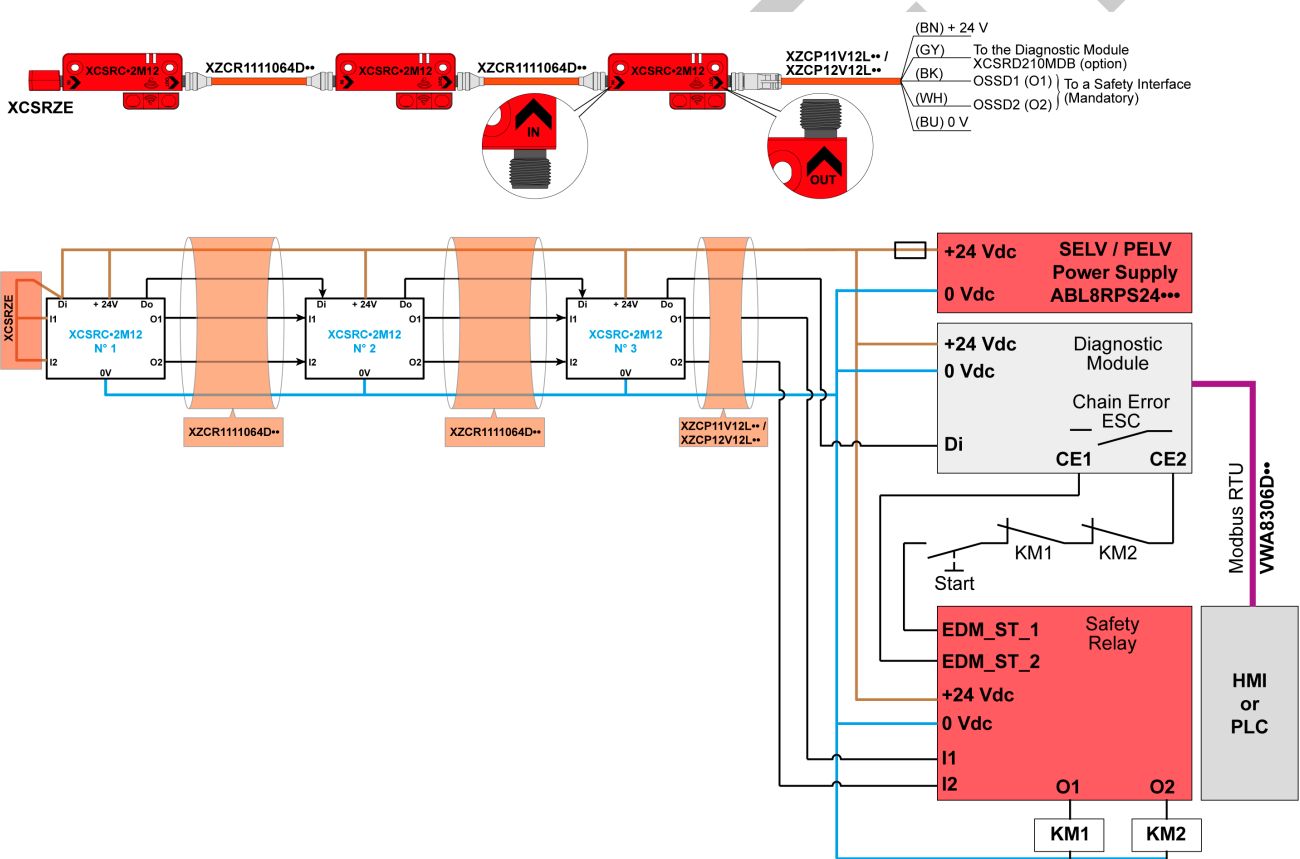

- Di** Diagnostic signal input
- Do** Diagnostic signal output
- I1** Safety Input 1
- I2** Safety Input 2
- O1** Safety Output 1
- O2** Safety Output 2
- CE1 & CE2** Connections for Chain Error contact (used as External Start Condition -ESC)
- BN** Brown
- WH** White
- BU** Blue
- BK** Black

GY Grey

DRAFT

Wiring

Inputs / Power Supply Wiring

Five screw terminals (top):

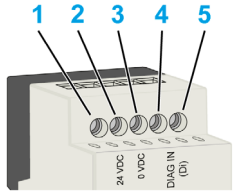
Pin out	Description	View
1	+24 Vdc	
2	0 Vdc	
3	Not connected	
4	Diagnostic input (Di)	
5	Not connected	

Communication Wiring

2 RJ45 8 wires:

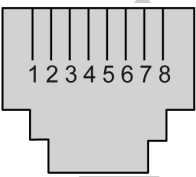
Pin out	Description	View
1	Not connected	
2	Not connected	
3	Not connected	
4	D1	
5	D2	
6	Not connected	
7	+5 Vdc	
8	Common (0 Vdc)	

CE Wiring

One terminal block:

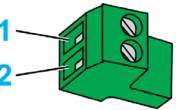
Pin out	Description	View
1	CE1	
2	CE2	

For more details, refer to Chain Error status description ([see page 84](#)).

Chain Error (CE / External Start Condition)

The diagnostic module provides a potential free contact.

The Chain Error contact (CE) does not provide information to stop the machine and is not part of the safety function.

The Chain Error contact (CE) opens in the following cases:

- During the initialization state,
- In error state ([see page 85](#)).

Otherwise the Chain Error contact is closed.

Once opened, CE cannot be closed until next power-up and restart cycle (if the configuration and the number of switches are consistent and if the XCSR210MDB are not in fail conditions).

For example, the Chain Error contact can be used to detect a difference between the number of XCSR210MDB physically connected in series and the number configured on the micro-switches (For example: sensor by-pass).

Diagnostic LED

Overview

The diagnostic module has two three-color LEDs

- One LED for the diagnostic function.
- One LED for the Modbus function.

Diagnostic LEDs

Diagnostic LED Description:

Color	Description
Orange	Initialization state.
Green	Run state: Correct diagnostic data frame received.
Red	Error state: <ul style="list-style-type: none"> • Inconsistency between the number of XCSR210MDB physically connected in series and the value set on the micro-switches, • The number of XCSR210MDB chained is greater than 20, • XCSRZE loopback device not connected, • At least one XCSR210MDB is in failure mode, • Detection of cable disconnection.
OFF	No diagnostic data received or no detected error or power off.

Modbus LEDs

Modbus LED Description:

Color	Description
Orange	Initialization state: Modbus auto baudrate detection function.
Green Blinking	Run state: Correct Modbus data frame received.
Red Blinking	Error state: Incorrect Modbus data frame received.
OFF	No Modbus data received or no detected error or power off.

Modbus Registers

Modbus Protocol

Main features:

Communication of the diagnostic data to a controller or an external display,

⚠ WARNING

IMPROPER CONNECTION

Controller or external display must be powered by the RJ45 (pin 7 and 8, Modbus CP5S).

Failure to follow these instructions can result in death, serious injury, or equipment damage.

The only supported Modbus request is Read holding registers (code 03h).

The Modbus protocol is Remote Terminal Unit (RTU).

NOTE: Connection to a Modbus TCP/IP device is possible with the use of TSXETG100 gateway. Refer to the Modbus TCP/IP wiring example (see page 86).

The detection of the Modbus line configuration is automatic. The automatic detection is activated after a power-up during the initialization phase. The duration of the initialization phase is 5 s.

Modbus settings accepted:

Type	Values
Baud rate (bit/s)	<ul style="list-style-type: none"> ● 9600 ● 19200 (by default) ● 38400 ● 57600 ● 76800 ● 115200
Parity	<ul style="list-style-type: none"> ● None (by default) ● Even ● Odd

Modbus TCP/IP Wiring Example

Connection of a XCSR210MDB to a Modbus TCP/IP device with a TSXETG100 gateway:

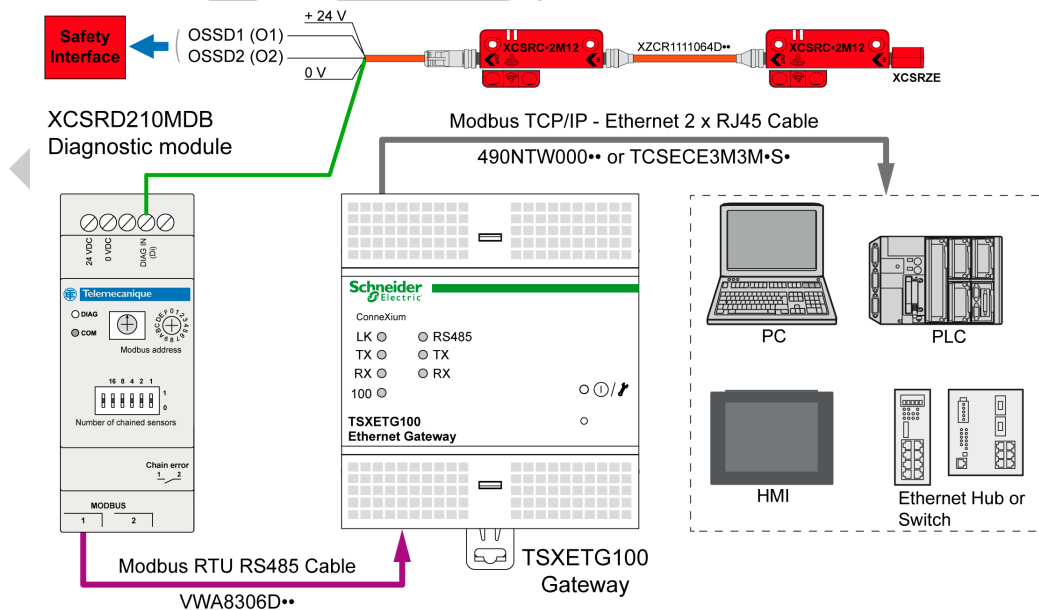

Modbus Registers

Modbus Registers:

Address	Register	Word	Description	Bit used
0x0000	1	Word 0	Error description	0...4
0x0001	2	Word 1	State of the first sixteen XCSR•2M12	0...15
0x0002	3	Word 2	State of the last four XCSR•2M12	0...3
0x0003	4	Word 3	Position of cable disconnection or XCSR•2M12 in failure mode.	0...4
0x0004	5	Word 4	Number of XCSR•2M12 in the chain set on the micro-switches.	0...4

User Registers

Register 1 = Word 0:

Bit	Default value	Value	Description
15 (MSB)	0	Not used	Not used
...	0	Not used	Not used
5	0	Not used	Not used
4	0	0 No detected error	Loopback device is not connected.
3	0	1 Detected error	Number of XCSR•2M12 chained is greater than 20.
2	0		Inconsistency between the number of XCSR•2M12 physically connected in series and the value set on the micro-switches. For example: <ul style="list-style-type: none"> • Wrong value set on the micro-switches, • Value of the micro-switches changed during operations, • Sensor by-pass attempt, • Wrong wiring,
1	0		XCSR•2M12 is in fail mode. In case of cable disconnection or invalid transponder detected during operations, this bit is also set to 1.
0	0	0 Open 1 Closed	State of the Chain Error contact relay.

Register 2 = Word 1. In normal operating condition, this word figures the guard states:

Bit	Default value	Value	Description
15 (MSB)	0	0 Guard opened or error detected (*)	Guard state of the XCSR•2M12 number 16
...	0	1 Guard closed	...
0	0		Guard state of the first XCSR•2M12

*: In Error mode, Word 1 = 0

Register 3 = Word 2. In normal operating condition, this word figures the guard states:

Bit	Default value	Value	Description
15...4	0	0	Not used
3	0	0 Guard opened or error detected (*)	Guard state of the XCSR•2M12 number 20
2	0	1 Guard closed	Guard state of the XCSR•2M12 number 19
1	0		Guard state of the XCSR•2M12 number 18
0	0		Guard state of the XCSR•2M12 number 17

*: In Error mode, Word 2 = 0

Register 4 = Word 3:

Bit	Default value	Value	Description
15...5	0	0	Not used
4	0	1...20 (dec)	Position of cable disconnection or XCSR•2M12 in failure mode (for example, invalid transponder detected).
3	0		
2	0		
1	0		
0	0		

Register 5 = Word 4:

Bit	Default value	Value	Description
15...5	0	0	Not used
4	0	0...20 (dec)	Number of XCSR•2M12 set on the micro-switches.
3	0		
2	0		
1	0		
0	0		

Example

Five XCSR•2M12 are connected in daisy chain to a safety interface and a diagnostic module:

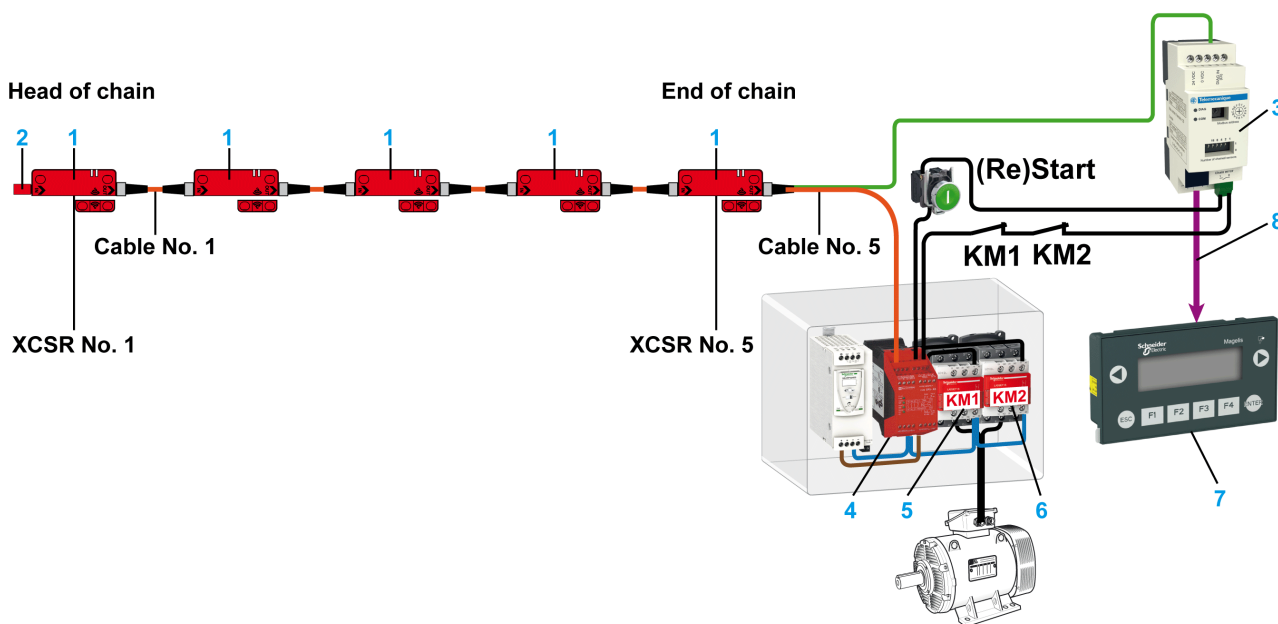

- 1 XCSR•2M12: XCSR RFID Safety Switch Daisy-Chain model
- 2 XCSRZE: Loopback device
- 3 XCSR210MDB: Diagnostic module
- 4 XPSAK...: Safety relay
- 5 KM1: contactor 1 - OSSD1
- 6 KM2: contactor 2 - OSSD2
- 7 XBTN...: Magelis Terminal (programming cable RJ45/USB: TCSMCNAM3M002P)
- 8 VW3A8306R...: 2xRJ45 Modbus cable

Example 1: the third guard is opened:

Word	Bits															
	15	14	13	12	11	10	9	8	7	6	5	4	3	2	1	0
0	0											0	0	0	0	1
1	0	0	0	0	0	0	0	0	0	0	0	1	1	0	1	1

Word	Bits															
	15	14	13	12	11	10	9	8	7	6	5	4	3	2	1	0
2	0											0	0	0	0	
3	0											0	0	0	0	
4	0											0	0	1	0	1
OSSD												OFF	OFF	OFF	ON	ON

Example 2: the fourth cable is disconnected:

Word	Bits															
	15	14	13	12	11	10	9	8	7	6	5	4	3	2	1	0
0	0											0	0	0	1	0
1	0	0	0	0	0	0	0	0	0	0	0	0	0	0	0	0
2	0											0	0	0	0	
3	0											0	0	1	0	0
4	0											0	0	1	0	1
OSSD												OFF	OFF	OFF	OFF	OFF

Example 3: the loopback device is not connected:

Word	Bits															
	15	14	13	12	11	10	9	8	7	6	5	4	3	2	1	0
0	0											1	0	0	0	0
1	0	0	0	0	0	0	0	0	0	0	0	0	0	0	0	0
2	0											0	0	0	0	
3	0											0	0	0	0	0
4	0											0	0	1	0	1
OSSD												OFF	OFF	OFF	OFF	OFF

Example 4: the number of XCSR•2M12 connected in serial is different than the one configured on the micro-switches (sensor by-pass or wrong configuration):

Word	Bits															
	15	14	13	12	11	10	9	8	7	6	5	4	3	2	1	0
0	0											0	0	1	0	0
1	0	0	0	0	0	0	0	0	0	0	0	0	0	0	0	0
2	0											0	0	0	0	
3	0											0	0	0	0	0
4	0											0	0	1	1	0
OSSD												ON	ON	ON	ON	ON

If the Chain Error contact is wired as External Start Condition, the system will not start after a power-up (and a restart command if required) until the inconsistency on the number of switches present/configured has been cleared.

Operating

Operating Hardware Installation

Installation of the diagnostic module (module not connected and not powered):

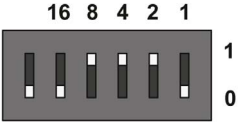
Step	Action
1	<p>Configure the Modbus slave address with the rotary switch (the address 0 is reserved).</p>  <p>You can set the Modbus address at any time and during any operating mode. There are 15 possible Modbus addresses (1...15).</p>
2	<p>Configure the number of XCSRC•2M12 present on the safety chain with the micro-switches:</p>  <p>This value must be set before powering-up the product. Example: the value set on the picture above is 14(dec), binary code equal to: $1110 = 2^3 + 2^2 + 2^1$.</p>
3	Wire the diagnostic module (see page 84).
4	Power up the module.

The diagnostic module goes to Initialization state.

Initialization State

During this state:

- The two LEDs are orange
- The contact Chain Error is opened

At power-up, the following initialization steps are automatically performed:

Step	Action	Description
1	Acquisition of the number of XCSRC•2M12 on the chain set on the micro-switches.	NB: Once in operation, the micro-switches cannot be changed. The micro-switch changes are taken into account after a power cycle only. If you change this value, the diagnostic module falls into error. This error is blocking and a restart is mandatory. To change this value, power off the module, reconfigure it, and then restart.
2	Acquisition of the Modbus slave address set previously on the rotary switch.	You can set the Modbus address at any time and during any operating mode.
3	Modbus register initializations (by default)	-
4	The diagnostic module goes to Run state.	-

Run State

This step follows the initialization step of diagnostic function and Modbus function.

At each reception of diagnostic data, Modbus registers are updated.

Diagnostic function:

If no diagnostic frame is received within a timeout of 3 s or diagnostic frame are incorrect, the diagnostic module enters in error state.

The error suppression and a new start are necessary to leave the error state.

The reception of a diagnostic frame is indicated by flashing of diagnostic LED.

For more details, refer to the Diagnostic LED description ([see page 85](#)).

Modbus function (Modbus line configuration detection):

The reception of a Modbus frame is indicated by flashing of Modbus LED.

In case of Modbus communication detected error, no restart is required. If the detected error is canceled, the communication resumes automatically.

A Modbus detected error never affects the state of Chain Error contact.

For more details, refer to the Modbus LED description ([see page 85](#)).

DRAFT

Characteristics

Conformity/Approvals

This table provides the standards and approvals:

Conforming to standards	EN/IEC 60947-1, EN/IEC 61326-2-1 UL 508, CSA C22.2
Approvals	CE, cULus, EAC, RCM

Product Performances Requirements

Electrical characteristics:

Characteristics	Value
Power supply	The power supply must meet requirements of IEC 60204-1 relative to SELV/PELV power supply.
Operating supply voltage	+24 Vdc (+10%, -20%) = [+19.2 Vdc, +26.4 Vdc]
Power consumption	≤ 300 mA
Power on delay	< 5 s
Reverse polarity protection	Yes (excluding RJ45)
Input signal	Compatible with XCSRC•2M12 diagnostic signal
Protection	External fuse

Interface:

Characteristics	Detail	Value
Relay	Type	Mechanical
	Current	<200 mA
	Voltage	≤+24 Vdc
	Ton	1 ms / 3 ms
	Toff	1 ms / 3 ms
Output power (RJ45)	Voltage	+5 Vdc (+/- 6%) = +4.7 Vdc,... +5.3 Vdc,
	Current	<200 mA (protected)
Modbus	Baudrate	Refer to Modbus settings accepted (<i>see page 86</i>).
	Parity	
	Registers	
	Pull out resistance	Pull up: 562 Ω, pull down: 562 Ω

Electromagnetic compatibility:

Characteristics	Conform to
EMC immunity withstands	EN 61326-2-1

Mechanical characteristics:

Characteristics	Detail	Value
Housing material	-	Polycarbonate
Display	Type	Two three-color LEDs (red, orange, green)
Degree of protection	-	IP20
Shock resistance	-	15 gn / 11 ms Conforming EN/IEC 60068-2-27
Vibration resistance	-	Conforming EN/IEC 60068-2-6 +/- 3.5 mm (0.138 in) 5...8.4 Hz 1 g (8.4...150 Hz)
Impact	-	IK04
Temperatures	Operating	0...60 °C (32...140 °F)
	Storage	-40...+85 °C (-40...185 °F)
Humidity	-	<95% without condensation



A

ANSI

American National Standards Institute. The administrator and coordinator of the U.S. private sector standardization system.

AWG

(American wire gauge) The standard that specifies wire section sizes in North America.

C

Category (Cat.)

Describe the safety-related parts of control systems performance in relation to their ability to resist to failures and resulting behavior in case of failure. Five categories are defined depending on design architectures.

Control-reliable

The device, system, or interface shall be designed, constructed, and installed such that a single component failure within the device, interface, or system shall not prevent normal stopping action from taking place, but shall prevent a successive machine cycle (ANSI B11.191).

E

EDM/MPCE (External Device Monitoring/Machine Primary Control Element Monitoring)

A means by which the XCSR RFID switch monitors the state of external control devices.

EMC

(ElectroMagnetic Compatibility)

I

IEC

(International Electrotechnical Commission) A non-profit and non-governmental international standards organization that prepares and publishes international standards for electrical, electronic, and related technologies.

IP69K

Protection classification according to DIN40050 relative to high pressure cleaning test.

IP 67

(ingress protection) The protection classification according to IEC 60529. IP 67 modules are protected against ingress of dust, contact, and water up to an immersion depth of 1 m.

M

Mission Time

Period of time covering the intended use of a safety related system.

O

Off state

The state in which the output circuit is interrupted (open) and does not allow current to flow.

On state

The state in which the output circuit is complete (closed) and allows the flow of current.

Output Safety Switching Device (OSSD)

The component of the XCSR RFID switch connected to the machine control system which, when the guard door is open, responds by going to Off state. This is also known as a safety output.

P**Performance level (PL)**

Ability of safety-related parts of control systems (SRP/CS) to perform a safety function in order to achieve the required risk reduction.

Probability of Dangerous Failure per Hour

(PFH_D) Average probability of dangerous failure per hour for high demand mode of operation.

R**Response times**

Refer to Definition of Characteristic Times (*see page 18*).

S**Safety Integrated Level (SIL)**

The failure mode evaluation based on the risk assessment in accordance with IEC 61508. Estimation of the required SIL is performed for each safety-related control function (SRCF) and represent the levels that the control-command must respect according to the known risk factors associated with the installation. Level 3 is the highest and Level 1 the lowest level.

Safety Integrated Level Claim Limit (SILCL)

Maximum SIL that can be claimed for safety function of any subsystem.

Sao (Assured Operating Sensing Distance)

S_{ao} is the distance from the sensing face within which the presence of the specified target is correctly detected under all specified environmental conditions and manufacturing tolerances

Sar (Assured Release Sensing Distance)

S_{ar} is the distance from the sensing face beyond which the absence of the specified target is correctly detected under all specified environmental conditions and manufacturing tolerances

SELV

(*safety extra low voltage*) A system that follows IEC 61140 guidelines for power supplies is protected in such a way that voltage between any 2 accessible parts (or between 1 accessible part and the PE terminal for class 1 equipment) does not exceed a specified value under normal conditions or under inoperable conditions.