



Gogo Video Processing Unit (GVPU) Installation Manual

**Installation Manual part number D18340
Revision A, May 2015**

Gogo Business Aviation
105 Edgeview Drive, Suite 300
Broomfield, CO 80021

Distribution Statement: This publication is for the Gogo Video Processing Unit product only and is to be used by customers and authorized Gogo Business Aviation agents only. Send requests for additional copies of this document to Gogo Business Aviation Customer Service at 1-888-286-9876.



PROPRIETARY NOTICE

This document and the information disclosed herein are proprietary data of Gogo Business Aviation. Neither this document nor the information contained herein shall be used, reproduced, or disclosed to others without prior written authorization of Gogo Business Aviation, except to the extent required for installation of recipient's equipment.

Notice

Freedom of Information Act (5 USC 552) and Disclosure of Confidential Information Generally (18 USC 1905)

Gogo Business Aviation is furnishing this document in confidence. The information disclosed here falls within exemption (b)(4) of USC 552 and the prohibitions of 18 USC 1905. For further information, please contact:

**Gogo Business Aviation
105 Edgeview Drive, Suite 300
Broomfield, CO 80021
Telephone: (303) 301-0278
FAX: (303) 301-0279**

**© 2015 Gogo Business Aviation
All Rights Reserved**

Information in this document is subject to change without notice and does not represent a commitment on the part of Gogo Business Aviation.

Trademark Acknowledgements

Gogo Business Aviation is a registered trademark, and Gogo Biz is a trademark, of Gogo Business Aviation and its affiliates. All rights reserved.

Trademarks and service marks owned by third parties are the property of their respective owners.



RECORD OF REVISIONS

REVISION	DESCRIPTION	RELEASE DATE	RELEASED BY
A	Initial Release	May 2015	Gogo Business Aviation



RECORD OF TEMPORARY REVISIONS

TEMPORARY REV. NO.	PAGE NUMBER	ISSUE DATE	BY	DATE REMOVED	BY



TABLE OF CONTENTS

<u>Subject</u>	<u>Page</u>
PROPRIETARY NOTICE.....	i
RECORD OF REVISIONS.....	ii
RECORD OF TEMPORARY REVISIONS.....	iii
TABLE OF CONTENTS	iv
LIST OF FIGURES	vii
LIST OF TABLES	viii
1.0 INTRODUCTION.....	1-1
1.1. General.....	1-1
1.2. Unpacking.....	1-2
1.3. Planning.....	1-2
1.4. List of Abbreviations and Acronyms	1-2
1.5. Advisories.....	1-3
1.6. FCC Compliance	1-4
1.7. List of Related Publications	1-6
2.0 DESCRIPTION AND OPERATION	2-1
2.1. Introduction and Overview.....	2-1
2.2. GVPUs Indicators.....	2-3
2.3. GVPUs Power	2-3
2.4. Component Part Numbers.....	2-3
2.5. General Purpose Input/Output.....	2-3
2.6. Physical Characteristics.....	2-3
3.0 INSTALLATION PROCEDURES	3-1
3.1. Planning.....	3-1
3.2. Equipment Location.....	3-1
3.3. Equipment Configuration.....	3-1
3.3.1. Considerations Regarding Current System	3-2
3.3.2. Sample Configurations.....	3-2
3.3.2.1. Single Digital Video Source	3-2
3.3.2.2. GVPUs as an Input Source to the CMS/A/V Distribution System.....	3-3
3.3.2.3. Multiple Video Sources; GVPUs after CMS	3-4
3.4. Cable Routing.....	3-5
3.5. Cabling.....	3-6
3.6. Antenna Mounting.....	3-8
3.7. Remote Ground Maintenance Ethernet	3-8
4.0 SETUP, CONFIGURATION, and FUNCTIONAL TESTING	4-1
4.1. Introduction	4-1
4.2. Test Results.....	4-1
4.3. Control and Operation	4-1
4.4. GVPUs Configuration	4-1
4.4.1. GVPUs Address Scheme.....	4-1



4.4.2.	Accessing the GGPU Configuration Page	4-2
4.4.2.1.	GGPU Configuration	4-4
4.4.2.2.	Player ID:	4-4
4.4.2.3.	Player Name:.....	4-5
4.4.2.4.	Connection Type:	4-6
4.4.2.5.	Wi-Fi: Enable/Disable.....	4-7
4.4.2.6.	Wi-Fi SSID:	4-8
4.4.2.7.	Wi-Fi Security:	4-8
4.4.2.8.	Wi-Fi Credentials:.....	4-8
4.4.2.9.	Audio Setting:	4-9
4.4.2.10.	Video Setting:	4-10
4.4.2.11.	Show Advanced Options.....	4-11
4.4.2.12.	Update	4-12
4.4.3.	GGPU Configuration – Advanced Options	4-13
4.4.3.1.	Audio Level:.....	4-13
4.4.3.2.	Wi-Fi Kill Switch:	4-14
4.4.3.3.	Wi-Fi Kill Switch Frequency:.....	4-15
4.4.3.4.	Heartbeat Frequency:	4-16
4.4.3.5.	Heartbeat Server Host:	4-16
4.4.3.6.	Heartbeat Server Port:	4-16
4.4.3.7.	Status Bar:	4-17
4.4.3.8.	Remote Logging:.....	4-18
4.4.3.9.	Remote Logging Level:	4-19
4.4.3.10.	A/V Bypass at Bootup:	4-20
4.4.3.11.	Update	4-21
4.5.	Functional Testing	4-22
4.5.1.	System Operational Checks.....	4-22
4.5.2.	Required System Components.....	4-22
4.5.3.	Operational Check: Configuration.....	4-22
4.5.4.	Operational Check: Streaming Video.....	4-23
4.5.5.	Operational Check: Composite Video.....	4-23
4.6.	Maintenance.....	4-24
4.6.1.	Inspection	4-24
4.6.2.	Mandatory Replacement Time	4-24
5.0	CLEANING.....	5-1
5.1.	Introduction	5-1
5.2.	Recommended Cleaning Materials	5-1
5.3.	Procedure.....	5-1
6.0	FITS AND CLEARANCES.....	6-1
6.1.	GGPU	6-1
7.0	SYSTEM SPECIFICATIONS	7-1
7.1.	Purpose.....	7-1



7.2.	Product Definition	7-1
7.3.	Associated Reference Documents	7-1
7.4.	Technical Specifications	7-1
7.4.1.	GVPU	7-1
8.0	SPECIAL TOOLS, FIXTURES, AND EQUIPMENT	8-1
8.1.	Introduction	8-1
8.2.	GVPU Configuration using Ethernet Interface	8-1
9.0	PARTS LIST	9-1
9.1.	Introduction	9-1
10.0	WIRING DIAGRAMS	1
10.1.	Wiring Diagrams.....	1
10.2.	GVPU	1
Appendix A: Troubleshooting Procedures.....		A-1
Appendix B: Instructions for Continued Airworthiness		B-1

DRAFT



LIST OF FIGURES

<u>Figure</u>	<u>Title</u>	<u>Page</u>
	The video content is streamed from the UCS content server to the GVPU via a wired Ethernet port. The GVPU outputs a composite video signal and/or an HDMI signal containing video data to the cabin monitor based on user selection. The composite video signal exits via a D-sub connector. The HDMI link uses a DVI-style connector which can be secured using the fixed jackscrews for use in a vibrating environment.....	2-1
Figure 2.2.	Sample GVPU Installation	2-2
Figure 3.1.	Single Digital Video Source	3-3
Figure 3.2.	Multiple Video Sources, GVPU Before CMS.....	3-4
Figure 3.3.	Multiple Video Sources, GVPU After CMS.....	3-5
Figure 4.1.	GVPU Configuration Page.....	4-3
Figure 4.4.	Player ID	4-4
Figure 4.5.	Player Name.....	4-5
Figure 4.6.	Connection Type	4-6
Figure 4.7.	Wi-Fi: Enable/Disable.....	4-7
Figure 4.8.	Wi-Fi SSID/ Security/ Credentials	4-8
Figure 4.9.	Audio Setting.....	4-9
Figure 4.10.	Video Setting	4-10
Figure 4.11.	Show Advanced Options.....	4-11
Figure 4.12.	Update	4-12
Figure 4.13.	Audio Level.....	4-13
Figure 4.14.	Wi-Fi Kill Switch	4-14
Figure 4.15.	Wi-Fi Kill Switch Frequency	4-15
Figure 4.16.	Heartbeat Frequency/Host/Port	4-16
Figure 4.17.	Status Bar	4-17
Figure 4.18.	Remote Logging.....	4-18
Figure 4.19.	Remote Logging Level.....	4-19
Figure 4.20.	A/V Bypass at Bootup.....	4-20
Figure 4.21.	Update	4-21
Figure A-1	GVPU Configuration Page.....	3



LIST OF TABLES

<u>Table</u>	<u>Title</u>	<u>Page</u>
Table 2.1.	GVPU Equipment Installed.....	2-3
Table 4.1.	Reference GPIO IP Address Mapping.....	4-2

DRAFT



This Page Intentionally Blank

DRAFT



1.0 INTRODUCTION

1.1. General

This installation manual (Gogo Video Processing Unit (GVPU), manual number D18340) provides the required instructions to install the GVPU.

The GVPU is an airborne-certified, Android-based video player device which serves as a sub-system of the Universal Cabin System (UCS) In-Flight Entertainment (IFE) system. Streaming media from the UCS content server is input to the GVPU via Ethernet Protocol and converted to a display format compatible with a cabin monitor. It is also capable of taking composite video input from devices such as Video Cassette Recorders (VCR), Digital Video Disk (DVD) players, or an Airshow system if the aircraft is so equipped. Selection of the video source can be controlled remotely.

The GVPU output is typically connected to a cabin monitor or Audio-Video distribution system. High-Definition Multimedia Interface (HDMI) video output is available in both "1080P" and "720P". Composite video output is also available.

A composite video bypass function is available wherein a composite video input is always present at the video output connector unless a movie or other digital video content is selected and playing.

A separate analog audio input connection provides for connection to a Cabin Management System (CMS), an Audio-Video (A/V) Distribution system, or other audio source. Audio output is available in either the Sony/Philips Digital Interface Format (S/PDIF) or analog format depending on the configuration of the audio portion of the aircraft IFE system.

General Installation Notes

- The GVPU must be installed inside the aircraft pressure vessel.
- Install the GVPU unit in locations that are free of water or other fluids, whether by direct contact or condensation.
- The GVPU is convection-cooled only and does not require any forced air or other form of cooling.
- Plan the installation to locate the GVPU near the cabin monitor to which it will be connected.

NOTE

The material in this manual is subject to change. Before planning or performing any installation operation, check with the www.my.gogoair.com website to verify this manual is complete and is the latest revision. The Record of Revisions, Record of Temporary Revisions, Service Bulletin List, and List of Effective Pages found at the front of this manual must match that issued as current by Gogo Business Aviation.

www.my.gogoair.com will have additional information that may be useful such as, Technical Bulletins and Tech Tips and Installation and Troubleshooting Tips.



Gogo Business Aviation welcomes your comments, suggestions, and corrections concerning this manual. Please include in your correspondence the publication number, equipment part number, page or figure number, and a brief description of any problem or consideration you noted. Please send your comments to:

Gogo Business Aviation
Sales Engineering Technical Publications
105 Edgeview Drive, Suite 300
Broomfield, Colorado 80021

1.2. Unpacking

Unpack the equipment carefully to save and ensure the integrity of the shipping package. Inspect each component for possible shipping damage. Report any damage to Gogo Business Aviation immediately. Use original packing material to return equipment to Gogo Business Aviation.

1.3. Planning

Proper and careful planning is essential for reliable system performance and ease of maintenance. The following are some considerations to follow when planning the installation:

- Study this manual carefully to get the complete picture of the installation process.
- Visit www.my.gogoair.com for additional information that may be useful, such as Technical Bulletins and Tech Tips and Installation and Troubleshooting Tips.
- Plan the location of the required equipment to ensure that the cable restrictions are met.
- Check cable routing, connector access (90 degree or straight), and determine cable lengths.
- Ensure easy accessibility to connectors for future repairs.

1.4. List of Abbreviations and Acronyms

A	Ampere	LRU	Line Replaceable Unit
AC	Advisory Circular	mA	milliamperes = .001 of an ampere
AWG	American Wire Gauge	MHz	Megahertz
CFR	Code of Federal Regulations	PED	Personal Electronic Device
CNS	Cabin Management System	P/N	Part Number
dB	Decibel	PoE	Power Over Ethernet
DC	Direct Current	P/N	Part Number
DHCP	Dynamic Host Configuration Protocol	RF	Radio Frequency
FAA	Federal Aviation Administration	RMA	Return Material Authorization
FAR	Federal Aviation Regulation	SAE	Society of Automotive Engineers
FCC	Federal Communications Commission	SIP	Session Initiation Protocol
GHz	Gigahertz	S/PDIF	Sony/Phillips Digital Interface Format
GPIO	General Purpose Input/Output	STC	Supplemental Type Certificate
GUI	Graphical User Interface	TC	Type Certificate
GVPU	Gogo Video Processing Unit	V	Volts
HD	High Definition	VDC	Volts Direct Current
HDMI	High Definition Multimedia Interface	WAP	Wireless Access Point
ICD	Interface Control Drawing	Wi-Fi	Wireless Fidelity



IP	Internet Protocol		
LAN	Local Area Network		
LED	Light Emitting Diode		

DO-160G	Environmental conditions and test procedures for airborne equipment development are produced by RTCA. The Federal Aviation Administration (FAA) generally accepts these conditions and procedures.		
---------	--	--	--

1.5. Advisories

WARNING

Statements in this Section contain critical safety information. Read these statements carefully before installing this unit.

WARNING

Observe standard safety precautions and wear safety glasses to prevent personal injury while installing this unit in the aircraft.

WARNING

Shut off power before connecting or disconnecting the GVPU as voltage transients may damage the unit or the interface wiring.

WARNING

Follow the manufacturer's safety guidelines when using any solvents, epoxies, flammable liquids, or any other materials during the installation processes. Some of these products are toxic to the skin, eyes, and respiratory tract. Avoid prolonged contact and use only in well-ventilated areas.

WARNING

Components or subassemblies found in this unit may contain materials such as beryllium oxide, acids, lithium, radioactive material, mercury, etc. that can be hazardous to your health. If the component enclosure seal is broken, precautions must be taken against personal contact or inhalation in accordance with Occupational Safety and Health Administration (OSHA) requirements 29 Code of Federal Regulations (CFR) 1910.1000 or superseding documents. **Any alteration of this product voids the FAA certification and the Gogo Business Aviation warranty.**

CAUTION

Use Isopropyl alcohol carefully as it may react with some plastics in the area. Isopropyl alcohol should be used to clean connector contacts and metal parts (if required).



1.6. FCC Compliance

Federal Communication Commission Interference Statement

This equipment has been tested and found to comply with the limits for a Class B digital device, pursuant to Part 15 of the FCC Rules. These limits are designed to provide reasonable protection against harmful interference in a residential installation. This equipment generates uses and can radiate radio frequency energy and, if not installed and used in accordance with the instructions, may cause harmful interference to radio communications. However, there is no guarantee that interference will not occur in a particular installation. If this equipment does cause harmful interference to radio or television reception, which can be determined by turning the equipment off and on, the user is encouraged to try to correct the interference by one of the following measures:

- Reorient or relocate the Wi-Fi antenna.
- Increase the separation between the equipment and the affected device.
- Connect the equipment to a different power source from the GVPU.
- Consult the dealer or an experienced radio/TV technician for help.

FCC Caution: Any changes or modifications not expressly approved by the party responsible for compliance could void the user's authority to operate this equipment.

This device complies with Part 15 of the FCC Rules. Operation is subject to the following two conditions: (1) this device may not cause harmful interference, and (2) this device must accept any interference received, including interference that may cause undesired operation.

IMPORTANT NOTICE:

FCC Radiation Exposure Statement:

This equipment complies with FCC radiation exposure limits set forth for an uncontrolled environment. This equipment should be installed and operated with minimum distance 20 cm between the radiator & your body.

This transmitter must not be co-located or operating in conjunction with any other antenna or transmitter.

Operations in the 5.15-5.25GHz band are restricted to indoor usage only.

Industry Canada statement:

This device complies with RSS-210 of the Industry Canada Rules. Operation is subject to the following two conditions: (1) This device may not cause harmful interference, and (2) this device must accept any interference received, including interference that may cause undesired operation.

Ce dispositif est conforme à la norme CNR-210 d'Industrie Canada applicable aux appareils radio exempts de licence. Son fonctionnement est sujet aux deux conditions suivantes: (1) le dispositif ne doit pas produire de brouillage préjudiciable, et (2) ce dispositif doit accepter tout brouillage reçu, y compris un brouillage susceptible de provoquer un fonctionnement indésirable.

Radiation Exposure Statement:

This equipment complies with IC radiation exposure limits set forth for an uncontrolled environment. This equipment should be installed and operated with minimum distance 20 cm between the radiator & your body.

Introduction, Section 1



Déclaration d'exposition aux radiations:

Cet équipement est conforme aux limites d'exposition aux rayonnements IC établies pour un environnement non contrôlé. Cet équipement doit être installé et utilisé avec un minimum de 20 cm de distance entre la source de rayonnement et votre corps.

Warning:

(i) Devices operating in the band 5 150-5 250 MHz is only for utilization in order to reduce the risk of harmful interference to mobile satellite systems using the same channels;

(ii) In addition, users should also be aware that users of high-power radars are designated primary users (i.e., they have priority) of the bands 5 250-5 350 MHz and 5 650-5 850 MHz and these radars could cause interference and/or damage to LE-LAN devices.

Avertissement:

(i) Les dispositifs fonctionnant dans la bande 5 150-5 250 MHz sont réservés uniquement pour une utilisation à l'intérieur afin de réduire les risques de brouillage préjudiciable aux systèmes de satellites mobiles utilisant les mêmes canaux;

(ii) De plus, les utilisateurs devraient aussi être avisés que les utilisateurs de radars de haute puissance sont désignés utilisateurs principaux (c.-à-d., qu'ils ont la priorité) pour les bandes 5 250-5 350 MHz et 5 650-5 850 MHz et que ces radars pourraient causer du brouillage et/ou des dommages aux dispositifs LAN-EL.

This device has been designed to operate with an antenna having a maximum gain of 4 dBi. Antenna having a higher gain is strictly prohibited per regulations of Industry Canada. The required antenna impedance is 50 ohms.

Approved antenna(s) list

Type	Gain
Omnidirectional	For 2.4GHz: 2.15 dBi
Omnidirectional	For 5 Ghz, 3.9 dBi



1.7. List of Related Publications

The following list includes related publications for the GVPU:

Publication	Publication Number
GVPU Installation Manual	Gogo Business Aviation D18340-A
Universal Cabin System Installation Manual	Gogo Business Aviation D17000
Acceptable Methods, Techniques, and Practices - Aircraft Alterations*	FAA Advisory Circular (AC) 43.13-2B
Acceptable Methods, Techniques, and Practices - Aircraft Inspection and Repair*	FAA AC 43.13-1B
Environmental Conditions and Test Procedures for Airborne Equipment	RTCA DO-160G
Shield Termination, Solder Style, Insulate, Heat-Shrinkable, Environment Resistant, General Specification For	Society of Automotive Engineers (SAE) AS83519
Aerospace Systems Electrical Bonding and Grounding for Electromagnetic Compatibility	SAE ARP1870

*Installation of the GVPU shall be performed in accordance with these FAA Advisory Circulars (as applicable).

2.0 DESCRIPTION AND OPERATION

2.1. Introduction and Overview

The Gogo Video Processing Unit (GVPU) enables the Gogo Universal Cabin System (UCS) to distribute and control both standard and High Definition video as well as stereo and high definition audio to typical business aviation cabin monitors and speakers. This functionality enables UCS Vision (movies, moving maps, news clips, weather updates) to be displayed on a permanently mounted cabin monitor. The UCS content server must be able to connect to the Internet externally for Digital Rights Management (DRM) when playing movies or TV shows.

An installation comprises of the GVPU (P24486) LRU as seen in Figure 2.1.



Figure 2.1. GVPU

Figure 2.2 displays a diagram of the GVPU with an example of possible aircraft IFE configurations.

The GVPU receives power from the 28 volt aircraft bus via a dedicated circuit breaker or the cabin monitor circuit breaker if this simplifies installation.

The GVPU outputs audio in S/PDIF format or analog format to the aircraft audio distribution system or direct to the fixed cabin monitor depending on the aircraft configuration.

The video content is streamed from the UCS content server to the GVPU via a wired Ethernet port. The GVPU outputs a composite video signal and/or an HDMI signal containing video data to the cabin monitor based on user selection. The composite video signal exits via a D-sub connector. The HDMI link uses a DVI-style connector which can be secured using the fixed jackscrews for use in a vibrating environment.

Key:
 Video
 Power & GPIO
 Audio
 Data

Aircraft Configuration

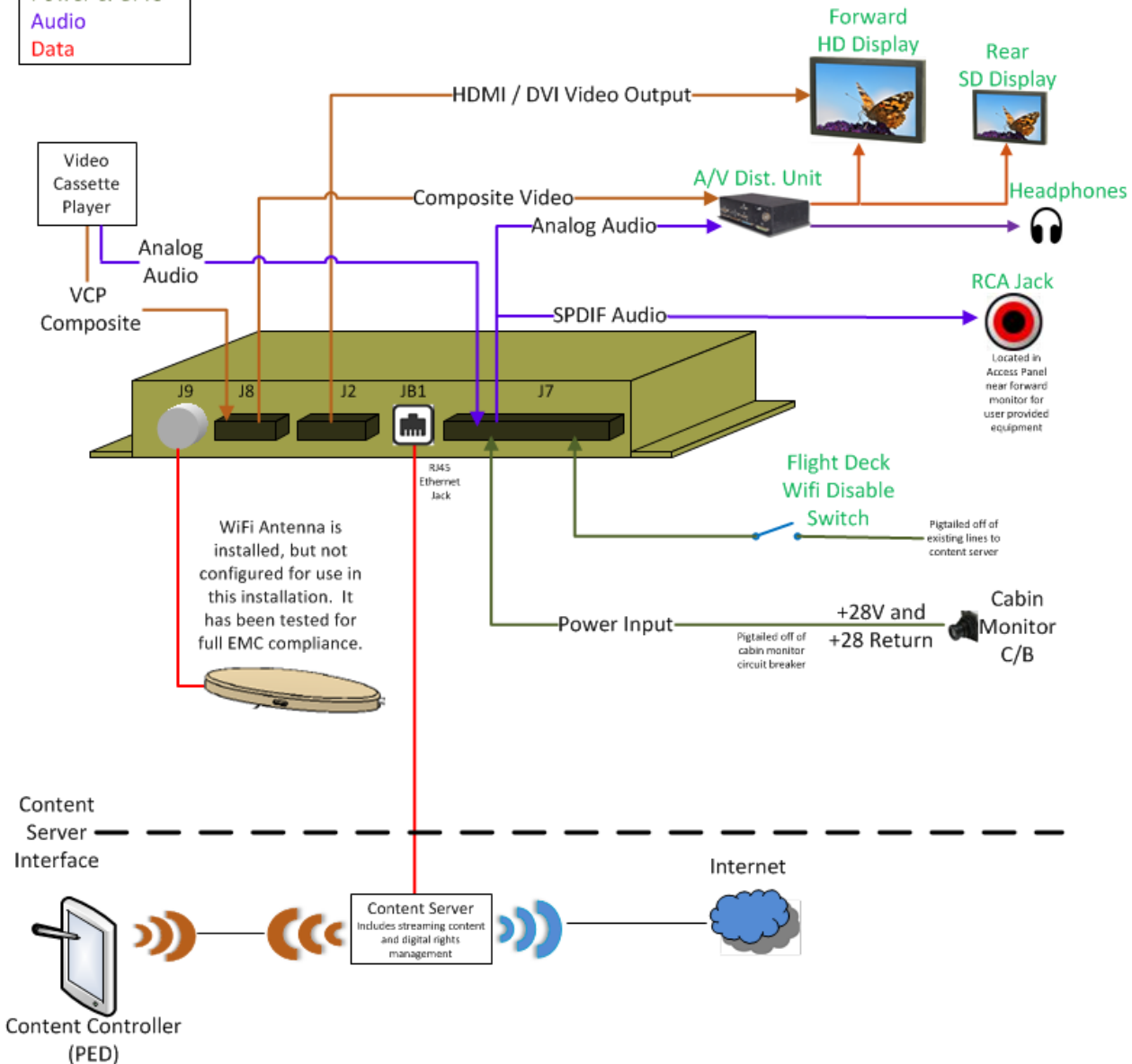

Figure 2.2. Sample GGPU Installation

The GGPU is mounted via holes in flanges at both ends of the enclosure.

The dimensions of the GGPU including mounting flanges are 3.23" W x 9.25" L x 1.33" H.



2.2. GVPU Indicators

The GVPU contains several internal LED indicators for power and general status. These are labeled on the exterior of the GVPU and the location and function are shown on the Interface Control Drawing (ICD) in Section 10 of this document.

2.3. GVPU Power

The GVPU must be installed within the aircraft pressure vessel. For an installation where the GVPU is powered through a dedicated circuit breaker, a 1 Amp circuit breaker is recommended.

As the GVPU consumes very little power, installation may be simplified if the GVPU is powered by the same circuit as the cabin monitor to which it will be connected. In this case, review the cabin monitor power requirements and adjust the monitor circuit breaker size accordingly to accommodate the incremental power draw of the GVPU.

2.4. Component Part Numbers

Description	Manufacturer	Part Number	Quantity	Applicability
GVPU	Gogo Business Aviation	P24486	1	All

Table 2.1. GVPU Equipment Installed

2.5. General Purpose Input/Output

The GVPU contains a number of definable General Purpose Input/Output (GPIO) connections. At present, only one GPIO1 N is used for a remote Wi-Fi disable capability when connected to a switch in the cockpit or to the Wi-Fi disable function on the Gogo UCS system. The remaining ports are reserved for future function expansion.

The GPIO ports are active low and each can handle 28 VDC at 50 mA.

2.6. Physical Characteristics

The GVPU has a mounted footprint 9.25" x 3.23". The height is 1.33" from the mounting surface to the top of the enclosure. Refer to the GVPU interface drawing D171130, in Section 6.0 for details.

The GVPU chassis is made of wrought aluminum alloy. An anodized finish is applied to all external surfaces, providing the chassis with excellent corrosion resistance, while also making it electrically nonconductive.

All of the electrical connections to the GVPU are on one side of the box which offers convenient access for maintenance purposes. The GVPU must be installed in the pressurized cabin area or avionics bay. Keep in mind the cable lengths and routing requirements. Depending on the placement of the unit, it may be necessary and/or desirable to use right-angle connectors. Ensure that connectors do not interfere with each other in the final selected configuration.



Refer to Section 7.4.1., GVPU System Specifications, for details regarding the environmental requirements for this unit. The GVPU has low power requirements such that natural convection cooling will be adequate for most mounting locations.

DRAFT



3.0 INSTALLATION PROCEDURES

3.1. Planning

Careful planning will ensure an efficient installation of the GVPU with minimum down time for the aircraft and will ensure optimal system performance and easy maintenance access in the future. Plan equipment locations with service in mind, and select the proper cabling before ordering.

Refer to aircraft manufacturing guidelines and/or Advisory Circular 43.13-1B and 2B. Advisory Circular 43.13-1B (Acceptable Methods, Techniques, and Practices) Chapters 11 and 12, and Advisory Circular 43.13-2B (Acceptable Techniques, and Practices-Aircraft Alterations) Chapters 1 and 2, and SAE AS83519 (Shield Termination, Solder Style, Insulate, Heat-Shrinkable, Environment Resistant, General Specification For) and SAE ARP1870 (Aerospace Systems Electrical Bonding and Grounding for Electromagnetic Compatibility) provide excellent guidelines to ensure a good installation.

A field-approved FAA Form 337, Supplemental Type Certificate (STC) or Type Certificate (TC) is the usual required documentation path for the installation of this system.

3.2. Equipment Location

If this is a new installation of a GVPU, select cabling as specified in this manual to satisfy the approved requirements of the system.

The GVPU must be located inside the pressure vessel. The LRU should be located near the cabin monitor to which it will be connected to avoid long runs of HDMI cabling. The LRU can be mounted in any orientation but be aware of any interference which may result between the electrical connectors and surrounding cabling or aircraft structure. Refer to Section 7.0, System Specifications, for details regarding the environmental requirements for this unit. Refer to Section 6.0 for mechanical installation details.

3.3. Equipment Configuration

There are many variations in how the GVPU may be configured as part of the aircraft's IFE system. The configuration selected will be based on several factors which will include the customer's requirements, the type of cabin monitor(s) on the aircraft, the capabilities of the existing CMS and/or A/V Distribution System, and how many existing audio/video resources are retained and need to be integrated with the GVPU.



3.3.1. Considerations Regarding Current System

Following is a list of questions to keep in mind when determining the optimal configuration for a specific installation. They may be used as is or adapted to any particular situation based on the level of complexity of the system.

Is there an A/V distribution System?

- What type of Audio/Video Input does it have
- Is there an available (unused) Audio/Video input.

Will the GVPU be connected directly to a monitor in the aircraft?

- Is there more than one cabin monitor?
- Is there an available HDMI or Composite input to the monitor?
- How will audio from the monitor be distributed throughout the aircraft?

3.3.2. Sample Configurations

Following are some examples of possible installation configurations. These should only serve as guidelines for actual installations as the final configuration will depend on numerous factors as described above.

3.3.2.1. Single Digital Video Source

For an aircraft installation with no A/V distribution system, the GVPU will be installed directly to a cabin monitor. Figure 3.1 shows a block diagram of this installation.

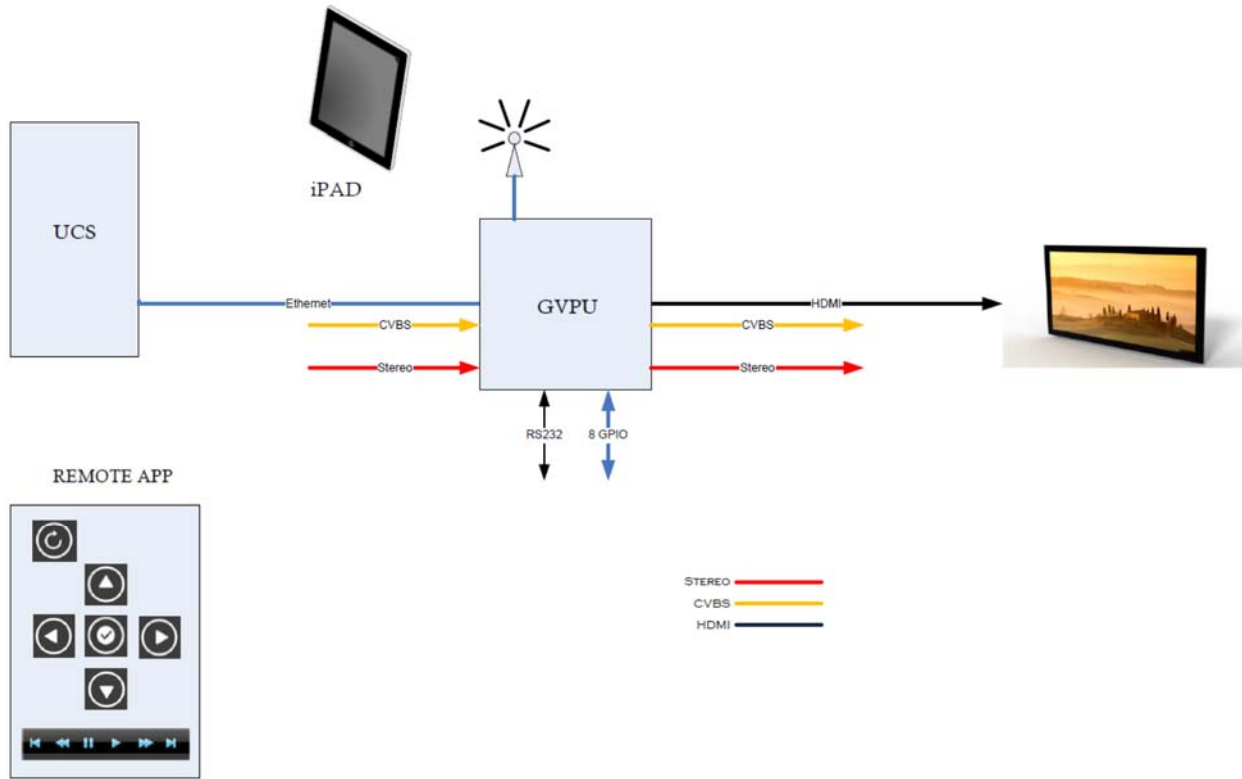

Figure 3.1. Single Digital Video Source

3.3.2.2. GVPU as an Input Source to the CMS/A/V Distribution System

Many aircraft will have an existing CMS or A/V distribution system with a variety of audio and video sources. In this case, the GVPU can be integrated to serve as an additional input to the existing system. Figure 3.2 shows some examples of this configuration. Some aspects to consider when the GVPU is integrated as in input source to the CMS or A/V distribution system:

- If an aircraft is equipped with more than one cabin monitor and each is intended to display individually controlled video, then more than one GVPU will need to be installed as input to the CMS or A/V distribution system. In this case (more than one GVPU installed), each GVPU will require a uniquely configured Internet Protocol (IP) address
- If more than one GVPU is installed, each GVPU will need to be configured with a unique IP address. See section 2.5 – General Purpose Input/Output for setting the IP address.

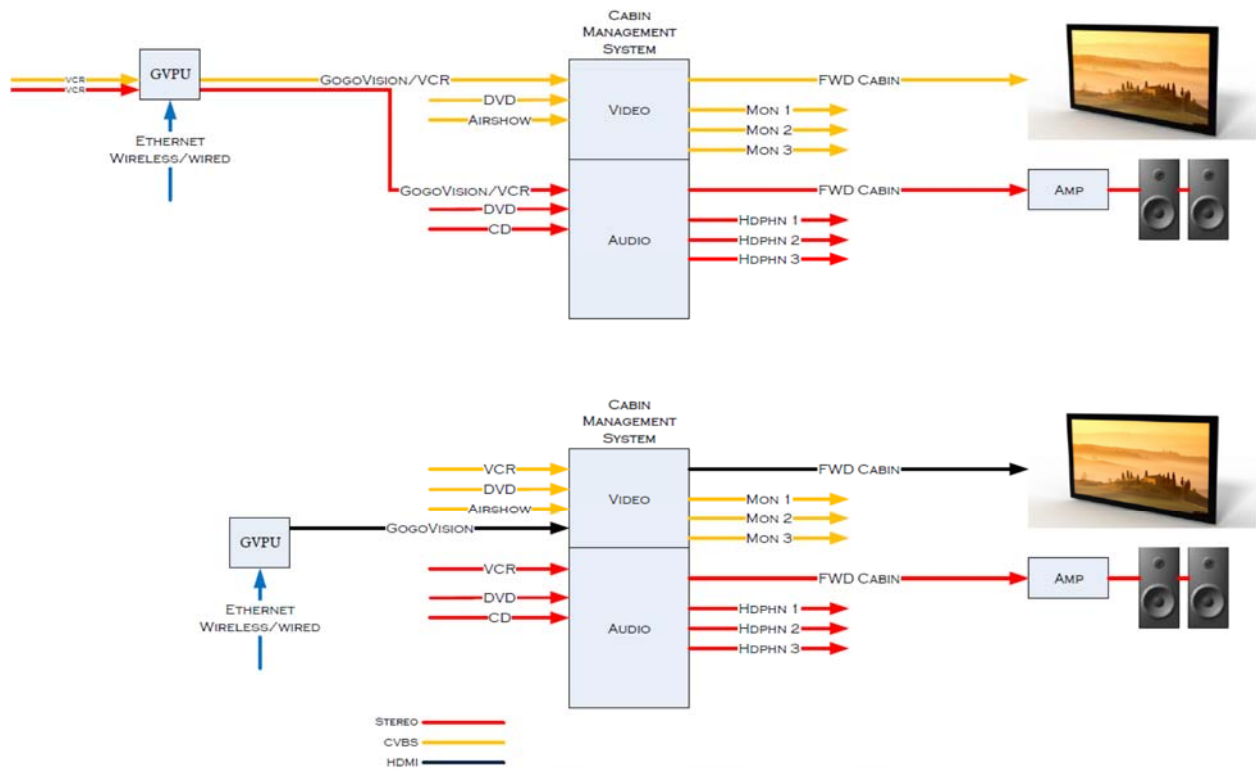

Figure 3.2. Multiple Video Sources, GVPU Before CMS

3.3.2.3. Multiple Video Sources; GVPU after CMS

An alternative is to integrate the GVPU downstream or after the existing/upgraded CMS. This configuration may be desirable if an HD capable cabin monitor is to be added solely to accommodate digital video from the Gogo UCS system or other digital video content server. An additional application provides the addition of HD video without changing the composite video source configuration and connection to the CMS. Figure 3.3 shows some examples of this configuration.

Some aspects to consider when the GVPU is integrated after the CMS are:

- Audio associated with HD video will only be available on cabin speakers unless the audio is routed back into the CMS.
- Audio volume control will be necessary at the amplifier unless audio is routed back into the CMS.

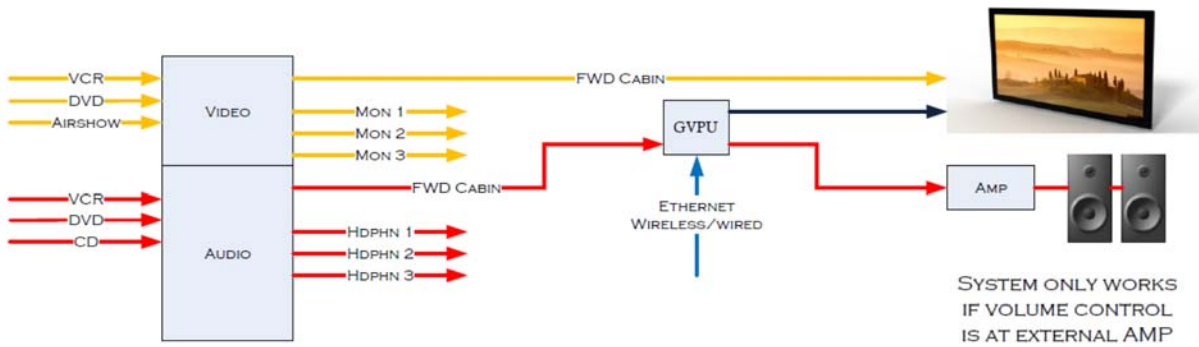
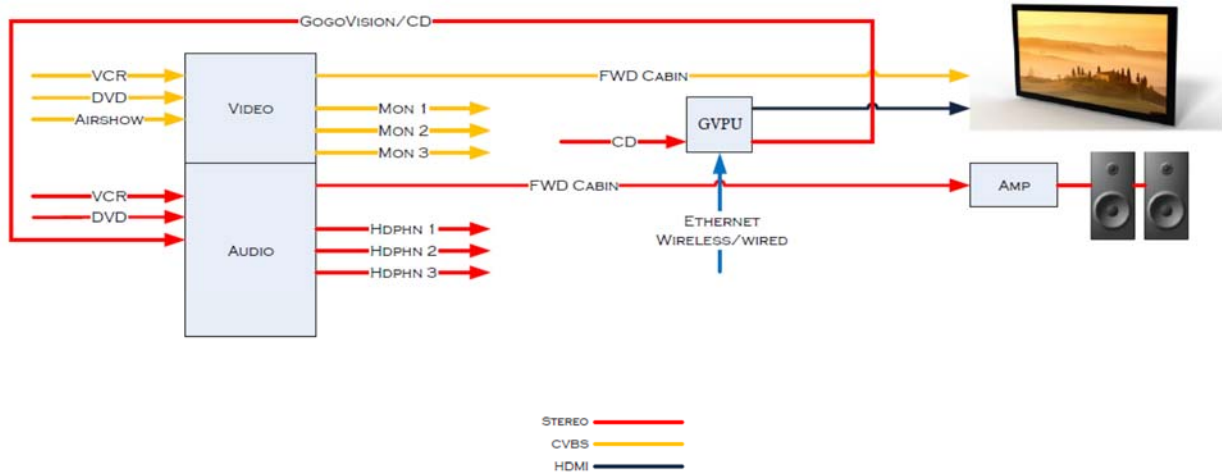

Figure 3.3. Multiple Video Sources, GVPU After CMS

3.4. Cable Routing

Draw a cable routing diagram for the aircraft. Refer to Wiring Instructions in Section 10.0 to determine the required cables, then measure and record the required cable lengths on a worksheet. Allow for adequate bend radius, service loops, and stress relief in all cable routes.



3.5. **Cabling**

The GVPV electrical connections are denoted as connectors JB1, J2, J7, J8, and J9. Detailed pin-outs and connector part numbers are shown in the ICD, drawing D17113 in Section 10.0

Connector JB1 is a standard RJ-45 Ethernet jack to enable an Ethernet connection to the device. Refer to Gogo drawing D17113 in Section 10.0.

Connector J2 is a Digital Video Interface (DVI) connector and provides the HDMI audio/video output. Refer to Gogo drawing D17113 in Section 10.0.

Connector J7 is a 37-pin d-sub connector and provides for DC power input, analog audio input and output, digital audio output, a USB connection (factory use only), two RS-232 ports (factory use only), and all GPIO connections. Refer to Gogo drawing D17113 in Section 10.0.

Connector J8 has a d-sub-style shell with three coaxial ports for composite video input, composite video output, and switched composite video output. Refer to Gogo drawing D17113 in Section 10.0.

Connector J9 is an SMA jack that has no use at this time. Refer to Gogo drawing D17113 in Section 10.0.

RF Transmission Characteristics, Wi-Fi

Operating Frequency Range..... 2.412 to 2.462 GHz
Transmit Power Less than 0.1 W max (less than 100 mW)
Per 802.11 b/g/n Wireless Broadband Router FCC Part 15 regulations

NOTE

Wire and Cable Installation

Wire installation should be done according to approved aircraft manufacturing guidelines and/or FAA procedures documented in Advisory Circular 43.13-1B. Consider cable slack, protection from heat, and protection from chafing when installing system wiring.

Good installation practices will ensure maximum performance for the GVPV. Advisory Circular 43.13-2B (Acceptable Techniques, and Practices - Aircraft Alterations), Chapter 1 and 2, Advisory Circular 43.13-1B (Acceptable Methods, Techniques, and Practices), Chapter 11, SAE AS83519 (Shield Termination, Solder Style, Insulate, Heat-Shrinkable, Environment Resistant, General Specification For) and SAE ARP1870 (Aerospace Systems Electrical Bonding and Grounding for Electromagnetic Compatibility) provide excellent guidelines to ensure a good installation. When building the system wire harness, observe the following:



1. Plan the GVPU cable routing so that it does not interfere with flight control cables or follow heavy current-carrying cables, hydraulic lines, or fuel lines.
2. It is essential to use military specification connectors or connectors approved for use on aircraft.
3. This document, attached ICD and attached wiring instructions only show a suggested circuit breaker size, wire size & type for a typical installation:
 - It is the responsibility of the installation agency to ensure proper wire type and size and the use of a properly rated circuit protection device (circuit breaker). In addition, ensure that the 28 VDC equipment bus is connected so it can handle the additional electrical load.
 - Install circuit protection (circuit breaker) of the proper amperage to handle the power requirements and protect the wiring.
 - Refer to aircraft manufacturing guidelines and/or refer to FAA Advisory Circular 43.13-1B, Section 11 (Aircraft Electrical Systems) for the proper wire types and circuit protection recommendations. All wiring and coax cabling shall conform to the flammability requirements of FAR 25.869.
 - Single wire conductors shall conform to aircraft manufacturing guidelines and/or the specification for Wire, Electrical, Fluoropolymer-Insulated, and Society of Automotive Engineers (SAE)-AS22759, also known as Military (MIL)-W-22759.
 - Shielded wire conductors shall conform to Aircraft manufacturing guidelines and/or the Standard for Aerospace and Industrial Electrical Cable, National Electrical Manufacturers Association (NEMA) WC 27500, also known as MIL-DTL-27500.
 - Size power wires and circuit protection to handle an operational voltage range 18.0 - 33.2 VDC with a nominal power draw of 7.6 watts @ 28 VDC and a maximum power draw of 14.0 watts @ 28 VDC.

The Wiring Diagrams in Section 10.0 provide manufacturing instructions for the wire harnesses. Notes on the wiring diagrams provide essential instructions that will save you needless rework during installation.

NOTES

Component Bonding

As with any communication equipment, bonding the equipment to the airframe ground is essential for optimum performance, compliance, and lightning protection. Ensure that the equipment mounting provisions (tray or bulkhead mounting rails) are bonded to the shelf, and the shelf is bonded to airframe ground. Properly bonded, there should be 2.5 milliohms or less between the mounting tray and airframe ground. Care in bonding has been shown to eliminate erratic or poor system performance.

Additional Shield Drain Information

As an option, up to four 22 American Wire Gauge (AWG) 7" drains may be combined on a single grounding strap and then routed to airframe chassis. The ground strap should be as short as possible, but may be realized with a maximum of 24" of insulated (18 AWG or larger).

4. To reduce EMI/RFI to an acceptable level, signal lines may require shielded cables. Refer to the wiring instructions in Section 10.0.



3.6. Antenna Mounting

The Wi-Fi antenna, used when the connection between the content server (UCS or other) is Wi-Fi instead of hardwired Ethernet, must be installed such that 20 cm is maintained between the antenna and the users under normal circumstances.

For optimal Wi-Fi performance, the Wi-Fi antenna should be mounted on a non-metallic surface and/or secured with cable ties. The Wi-Fi antenna can be mounted to a metallic surface, but should have direct line of sight (LOS) to the cabin in such a situation.

The Wi-Fi antenna is omni-directional but it is recommended to be mounted with the radome facing the target area.

3.7. Remote Ground Maintenance Ethernet

Normally, the GVPU will be utilized in conjunction with the Gogo UCS system to display video content on a cabin monitor or monitors. In this case, Ethernet access to the GVPU for configuration purposes can be made through the aircraft network used by all the UCS system components. The UCS may be connected through a Wi-Fi connection or the physical Ethernet jack on the GVPU. Instances where the GVPU is installed in a location that is not easily accessible, and the Ethernet jack is not used for connecting to the UCS system or other content server, it is recommended that the Ethernet port be wired to an easily accessible bulkhead-mounted or panel-mounted RJ-45 connector. This will provide a hardwired Ethernet connection to the GVPU for configuration and diagnostic purposes regardless of the status of the Wi-Fi connection.



4.0 SETUP, CONFIGURATION, and FUNCTIONAL TESTING

NOTE

READ THIS ENTIRE SECTION BEFORE PERFORMING ANY SETUP OR TESTING ON THE GOGO BUSINESS AVIATION EQUIPMENT!

Proper setup is an absolute requirement for the GVPU to function properly in the IFE system. DO NOT fly the aircraft unless all the steps have been completed correctly and verified.

4.1. Introduction

When the installation is complete and you have complied with the wiring and cabling requirements of this Manual (D18340), perform a final check of the Direct Current (DC) power input connections to the GVPU. Verify that ground and 28 VDC connections to the unit are correct and on the proper pin numbers. This will ensure confidence when you apply power to the unit for the first time. After verifying that the DC power inputs are on the proper power pins, pull open the circuit breaker and connect the power cable to the GVPU. Close the circuit breaker.

CAUTION

Before disconnecting or reconnecting the GVPU, pull open the power circuit breaker to avoid damage to the GVPU or the aircraft wiring.

4.2. Test Results

Documentation of the test results is important for the aircraft owner. All paperwork, provisioning, special drawings, cable routings, and special installation procedures should be included for the aircraft records.

4.3. Control and Operation

If there are any questions on this process please contact Gogo Business Aviation Customer Service at 1.888.286.9876.

4.4. GVPU Configuration

The GVPU is a configurable device which provides for customization to meet end customers' specific needs and desires. The following instruction will serve as a guideline to configure a GVPU installation based on how the GVPU is integrated into the aircraft IFE system.

4.4.1. GVPU Address Scheme

Refer to Table 4.1. for recommended GVPU IP assignments.

NOTE

Installers must take into consideration their particular IP address configuration when installing the GVPU with Networked Integrated Cabin Equipment (NICE).



Reference GPIO IP Address Mapping		
GVPU IP ADDRESS	PIN 29 (GPIO 2)	PIN 10 (GPIO 3)
172.20.10.10 (DEFAULT)	FLOATING	FLOATING
172.20.10.11	GROUNDING	FLOATING
172.20.10.12	FLOATING	GROUNDING
172.20.10.13	GROUNDING	GROUNDING

Table 4.1. Reference GPIO IP Address Mapping

4.4.2. Accessing the GVPU Configuration Page

To access the GVPU configuration page, connect a computer to the Ethernet network associated with the GVPU. This will typically be the primary aircraft data communications network to which the Gogo UCS system or other content server is connected.

If the connection between the GVPU and content server is via Wi-Fi and the Ethernet port on the GVPU (or its remote equivalent) is available, connect the computer here. In this case, it will be necessary to manually set an IP address on the computer as the GVPU does not have the ability to provide one. Use the following steps to prepare the computer:

1. Access the laptop's Control Panel and select **Network and Sharing Center**.
2. From the menu on the left side of the window, click on **Change Adapter Settings**.
3. Right click on the laptop's **Local Area Connection** (names may vary) and then click **Properties** in the subsequent drop-down menu.
4. In the center table of the new window, click on **Internet Protocol Version 4 (TCP/IPv4)** and then click **Properties** when it is highlighted.
5. If it's not already highlighted, click the **Use the following IP address:** radio button. Enter the following IP addresses then click **OK**:
 - a. IP address: **172.20.10.XX**, where **XX** is between **11** and **99**.
 - b. Subnet mask: **255.255.255.0**
 - c. Default gateway: **172.20.10.2**

Once connected, open a browser on the computer and navigate to the following IP address:

172.20.10.10

This will access the GVPU Configuration page which is shown in Figure 4.1.

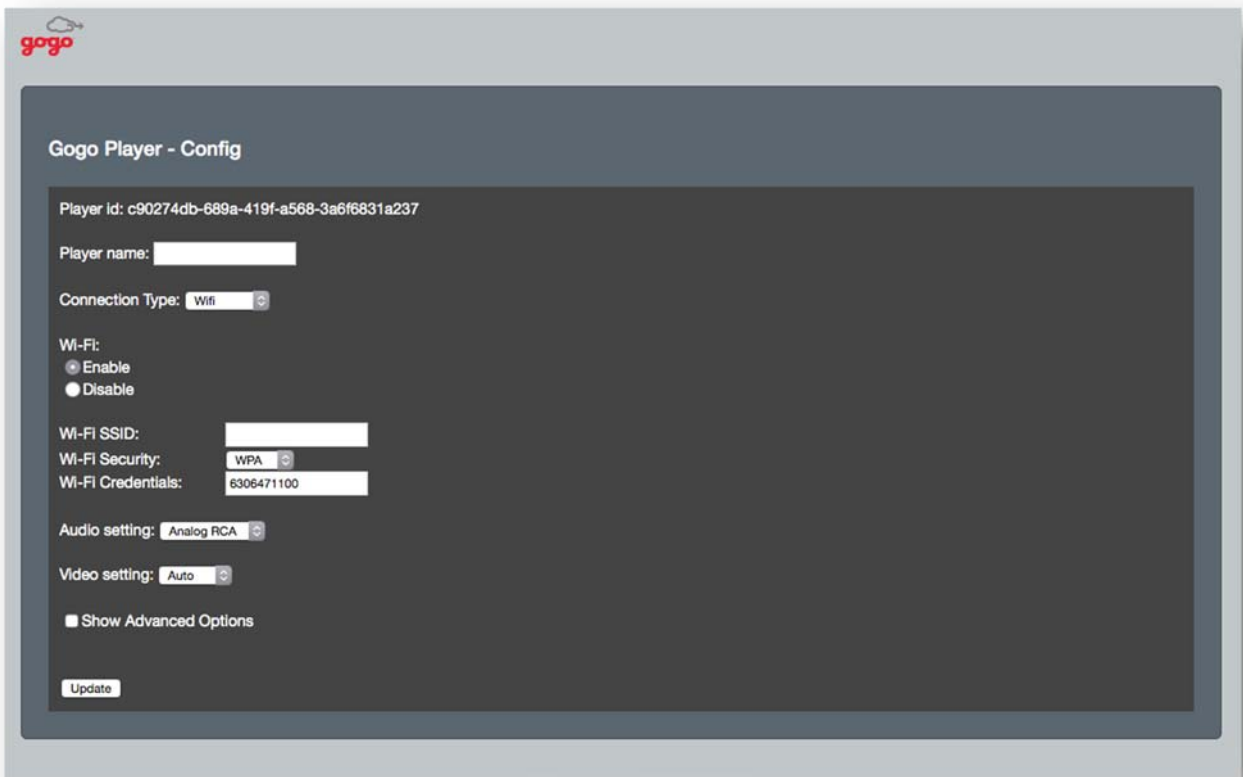

Figure 4.1. GVPV Configuration Page



4.4.2.1. GGPU Configuration

The configuration elements of the GGPU shown on the Configuration pages are described below:

4.4.2.2. Player ID:

The Player ID is automatically populated and should not be changed. This value is available for diagnostic purposes only.

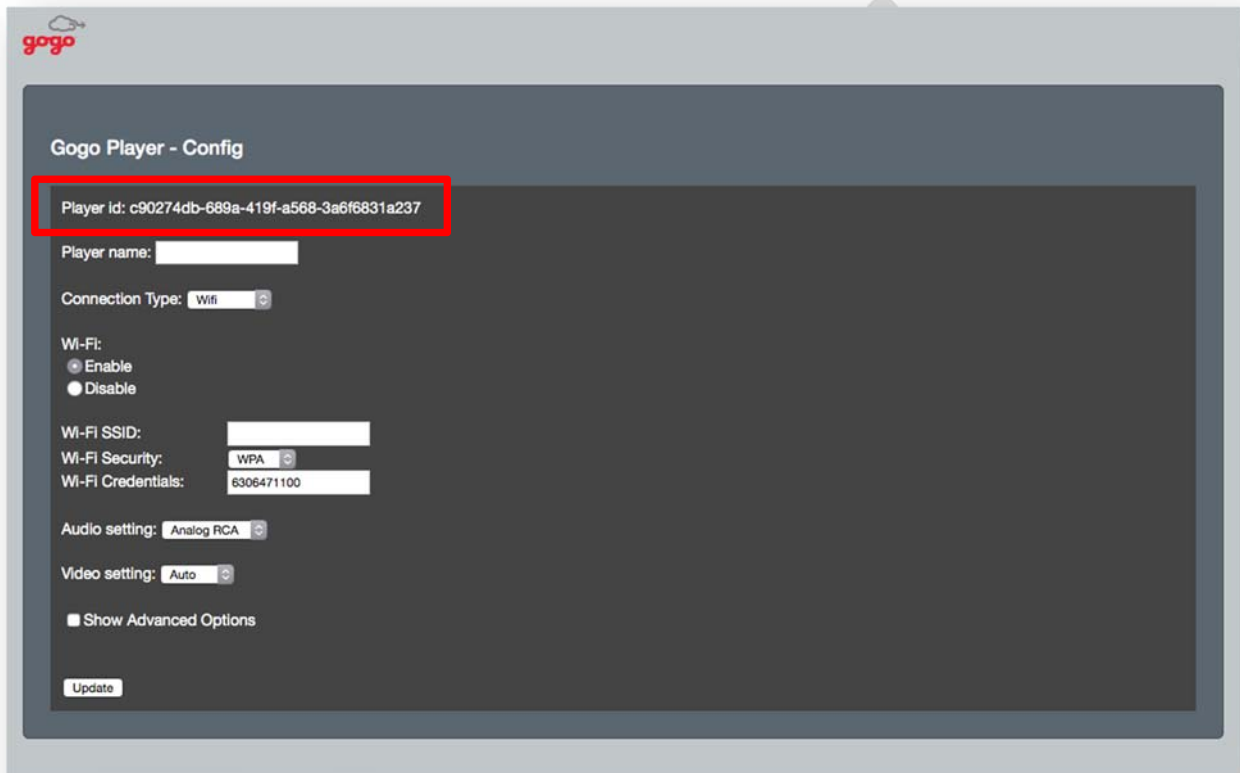

Figure 4.4. Player ID



4.4.2.3. Player Name:

Select the Player Name based on customer or operator preference. There are no limitations in regards to format. If more than one GVPU are installed on the same aircraft, choose unique names for each GVPU.

A screenshot of the "Gogo Player - Config" web interface. The interface is dark-themed with white text. At the top left is the "gogo" logo. Below it, the title "Gogo Player - Config" is displayed. The main content area shows the "Player Id: c90274db-689a-419f-a568-3a6f6831a237". Below this, the "Player name:" field is a white text input box, which is highlighted with a red rectangular border. Underneath, there are several configuration options: "Connection Type:" with a dropdown menu set to "Wifi"; "Wi-Fi:" with radio buttons for "Enable" (selected) and "Disable"; "Wi-Fi SSID:" with a text input field; "Wi-Fi Security:" with a dropdown menu set to "WPA"; "Wi-Fi Credentials:" with a text input field containing "6306471100"; "Audio setting:" with a dropdown menu set to "Analog RCA"; and "Video setting:" with a dropdown menu set to "Auto". At the bottom of the form is a "Show Advanced Options" checkbox and an "Update" button.

Figure 4.5. Player Name



4.4.2.4. Connection Type:

Connection type refers to the connection between the GGPU and the video content server, typically the Gogo UCS system. Set **Ethernet** when a hardwired Ethernet connection is used. This is the preferable connection type if the installation allows. Set **Wi-Fi** when a wireless connection is used because a hardwired Ethernet connection is not possible or desired. For a Wi-Fi connection, additional required configuration parameters are described below.

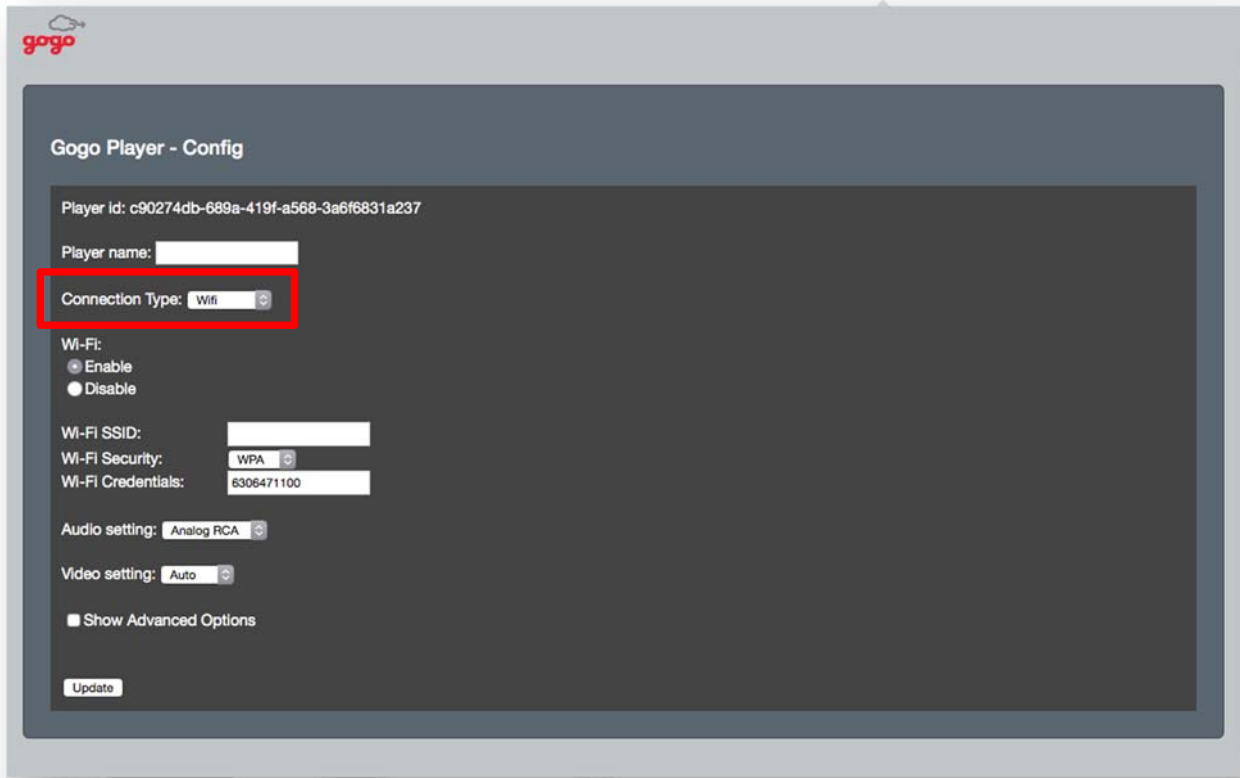

Figure 4.6. Connection Type



4.4.2.5. Wi-Fi: Enable/Disable

The Wi-Fi parameter provides two radio buttons:

- Select **Enable** when the connection between the GVP and video content server is Wi-Fi.
- Select **Disable** when the connection between the GVP and video content server is hardwired Ethernet. Also use this selection for specific diagnostic purposes even when the connection is Wi-Fi.

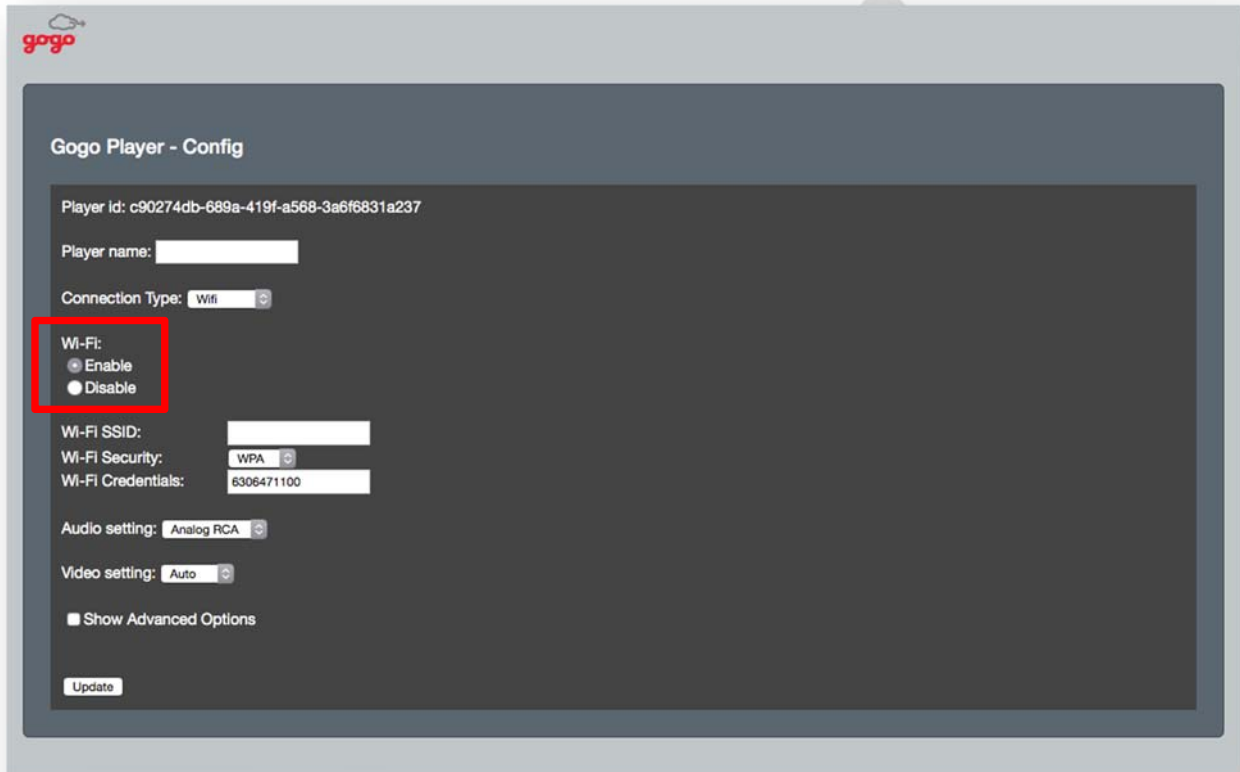

Figure 4.7. Wi-Fi: Enable/Disable



4.4.2.6. Wi-Fi SSID:

The Wi-Fi SSID is only necessary when the connection between the GVPU and video content server is wireless. This will typically be the SSID of the wireless access point (WAP) of the Gogo UCS system when installed. If an alternate content server is installed, use the SSID from this source.

4.4.2.7. Wi-Fi Security:

Set this parameter to match the security parameters of the video content server when the connection to the GVPU is Wi-Fi.

4.4.2.8. Wi-Fi Credentials:

Set this parameter to match the security parameters of the video content server when the connection to the GVPU is Wi-Fi.

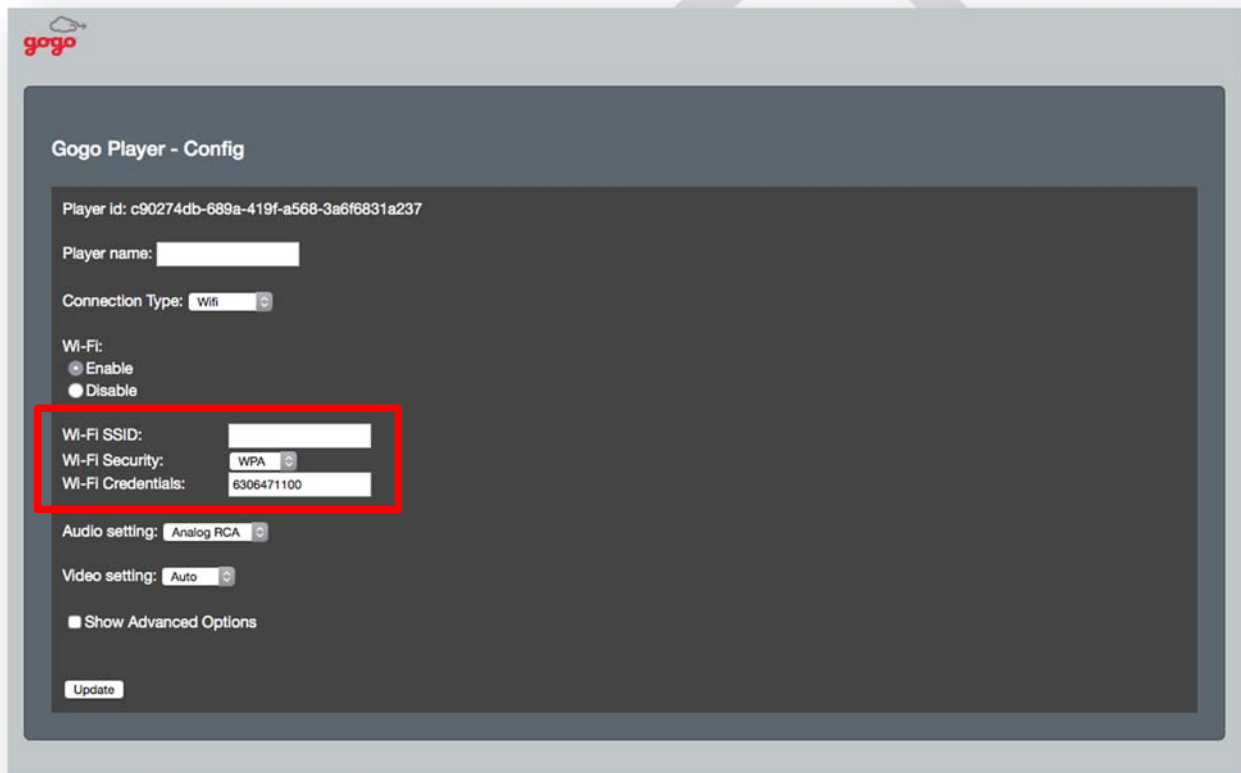

Figure 4.8. Wi-Fi SSID/ Security/ Credentials



4.4.2.9. Audio Setting:

The Audio Setting parameter determines the audio output format of the audio signal associated with digital input.

- Set this parameter to **S/PDIF** when a digital audio signal associated with the digital input is to be made available on the S/PDIF connections. Use the capability when the A/V Distribution system on the aircraft is capable of accommodating digital audio. When set to **S/PDIF**, any analog audio signal connected to the analog audio input connection will not be available on the analog audio output connection. Any analog audio signal connected to the analog audio input connection will only be available on the switched analog audio output connection when there is no digital audio as a result of no digital video input.
- Set the parameter to **Analog RCA** when any audio source is to be connected to a CMS or A/V distribution system only capable of accommodating analog audio signals. When set to **Analog RCA**, the audio input associated with a digital video input signal will be available on the switched analog audio output connection in analog format. Any analog audio signal connected to the analog audio input connection will only be available on the switched analog audio output connection when there is no digital audio as a result of no digital video input.

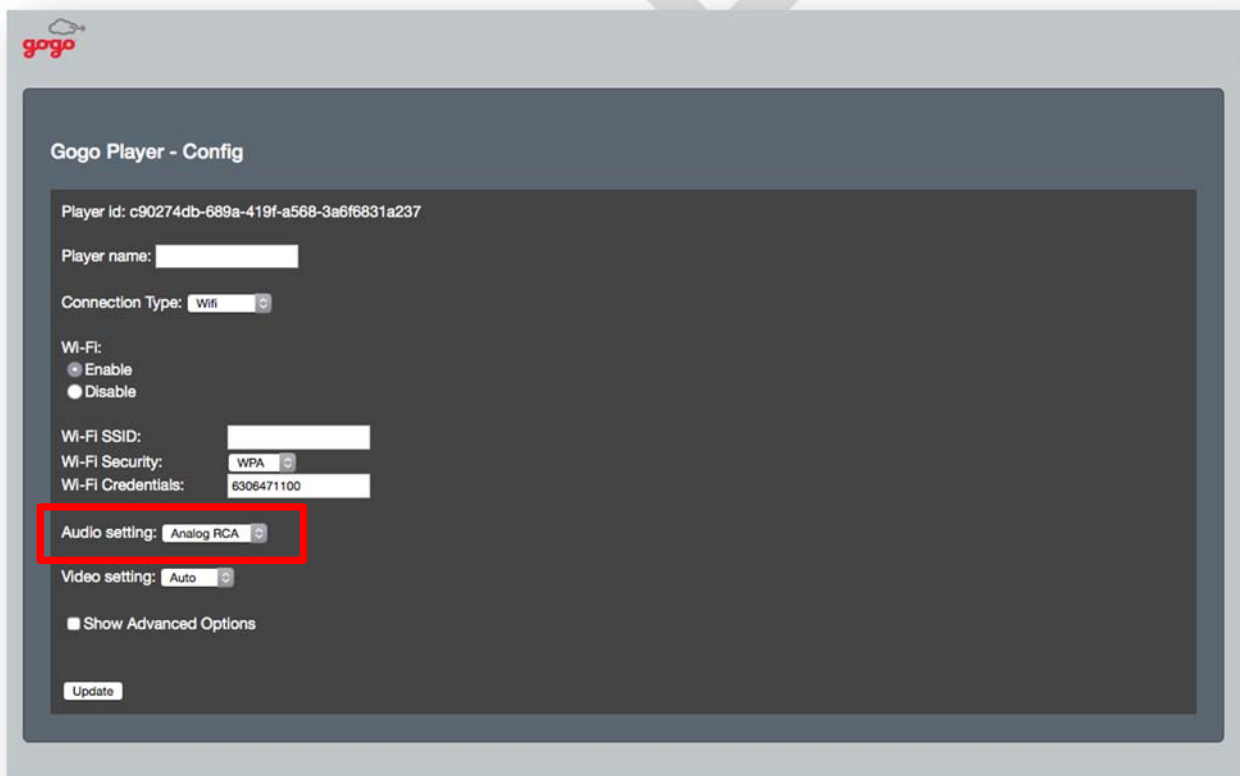

Figure 4.9. Audio Setting

4.4.2.10. Video Setting:

The Video Setting parameter determines the video output format associated with a digital input signal.

- Select **1080P** for maximum HD image resolution when the connected cabin monitor or CMS can accommodate this format.
- Select **720P** when the connected cabin monitor or CMS can only accommodate this format.
- Select **CVBS** when the desired video output is composite format as required by the cabin monitor or CMS.

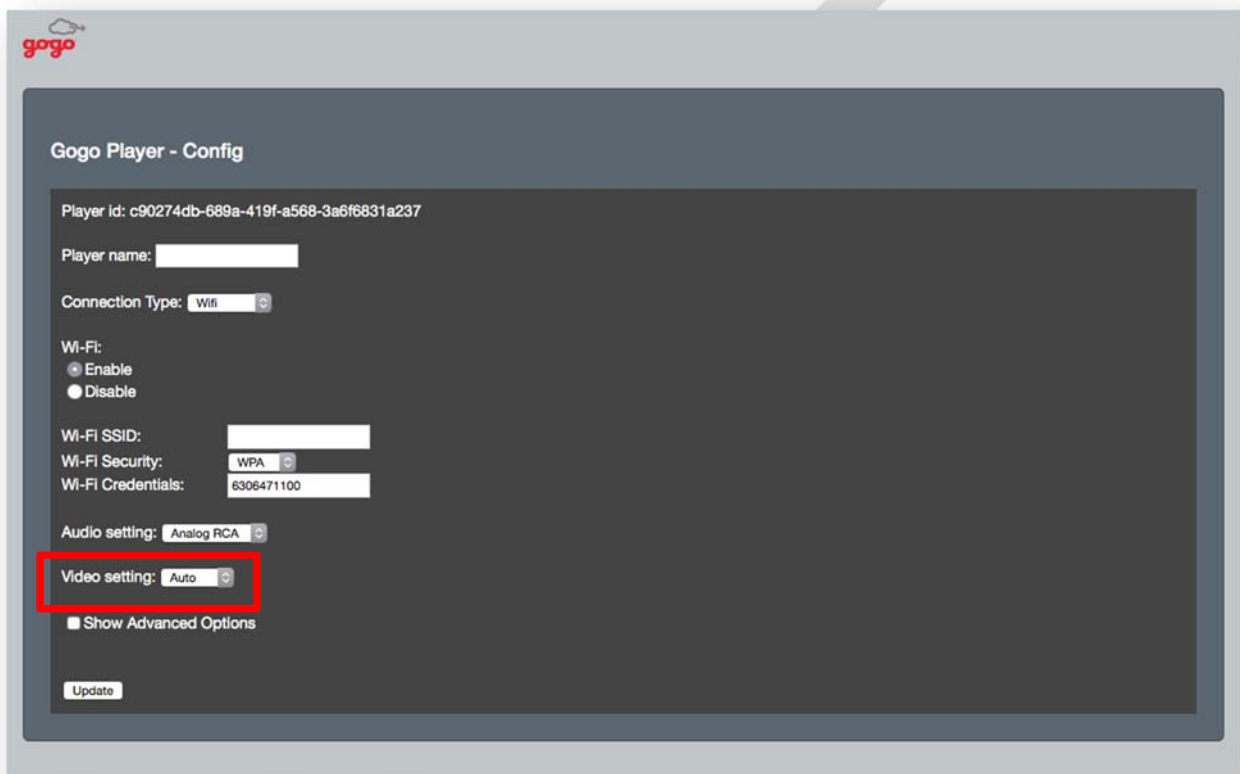

Figure 4.10. Video Setting

4.4.2.11. Show Advanced Options

Select the **Show Advanced Options** checkbox to access additional setup parameters.

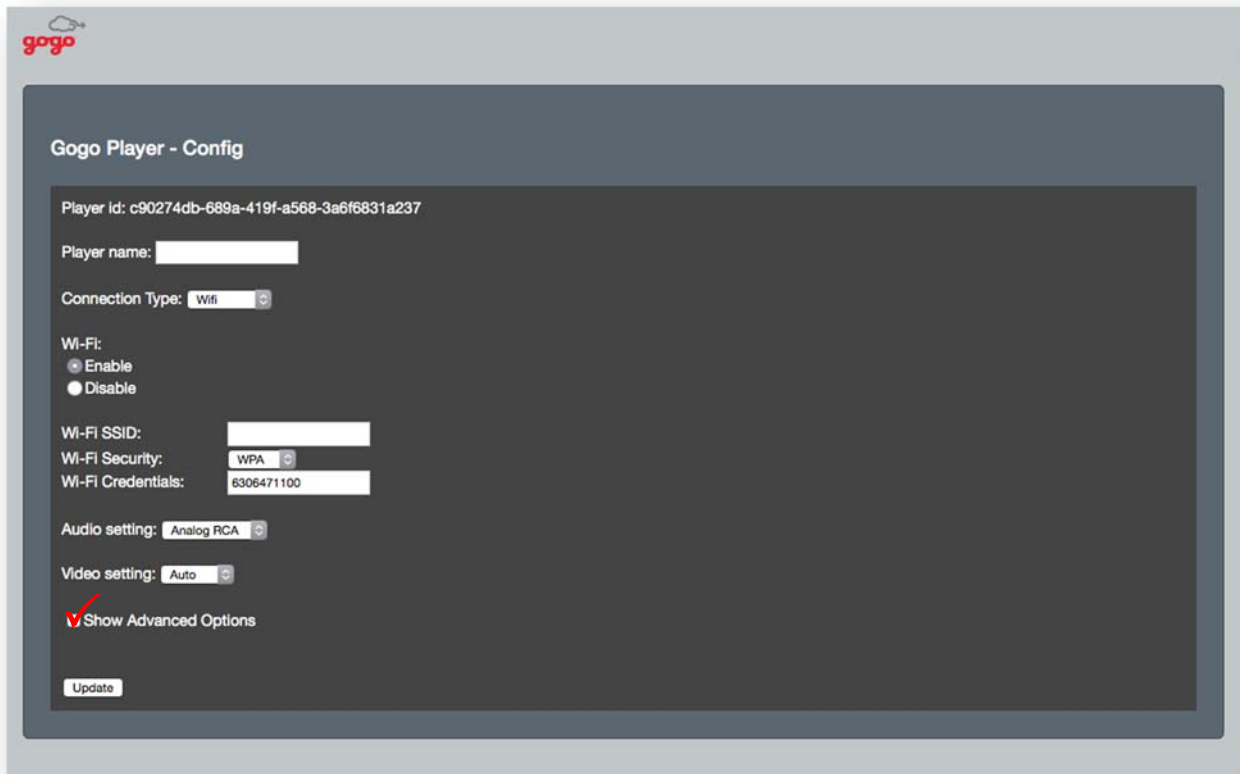

Figure 4.11. Show Advanced Options

4.4.2.12. Update

Press update to save changes.

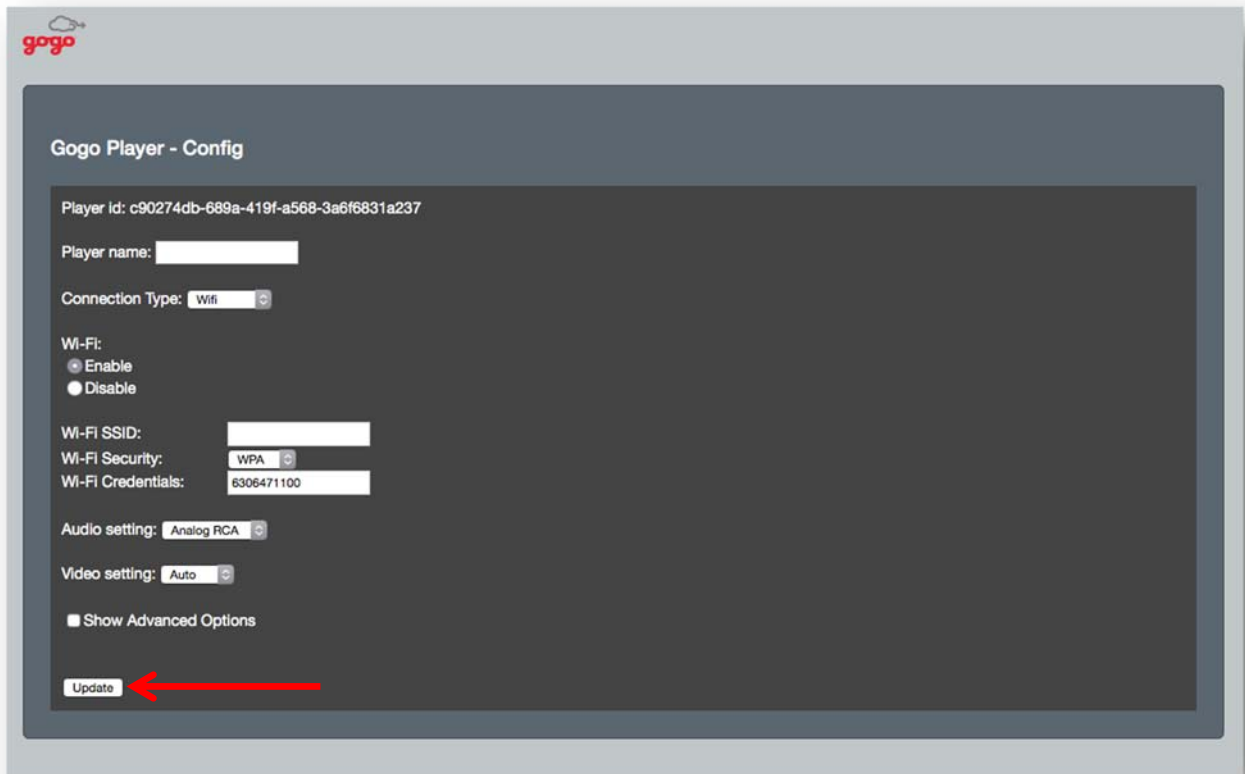

Figure 4.12. Update

4.4.3. GGPU Configuration – Advanced Options

4.4.3.1. Audio Level:

This parameter is the volume control for the GGPU but should only be used to fix an audio level to any device connected to the audio outputs. Actual audio levels as experienced by users of the system are to be set by other means such as remote controls. The range of settings is **1** to **16**. Set the audio level to **8** for most applications. Adjust this level up or down during system checkout as required.

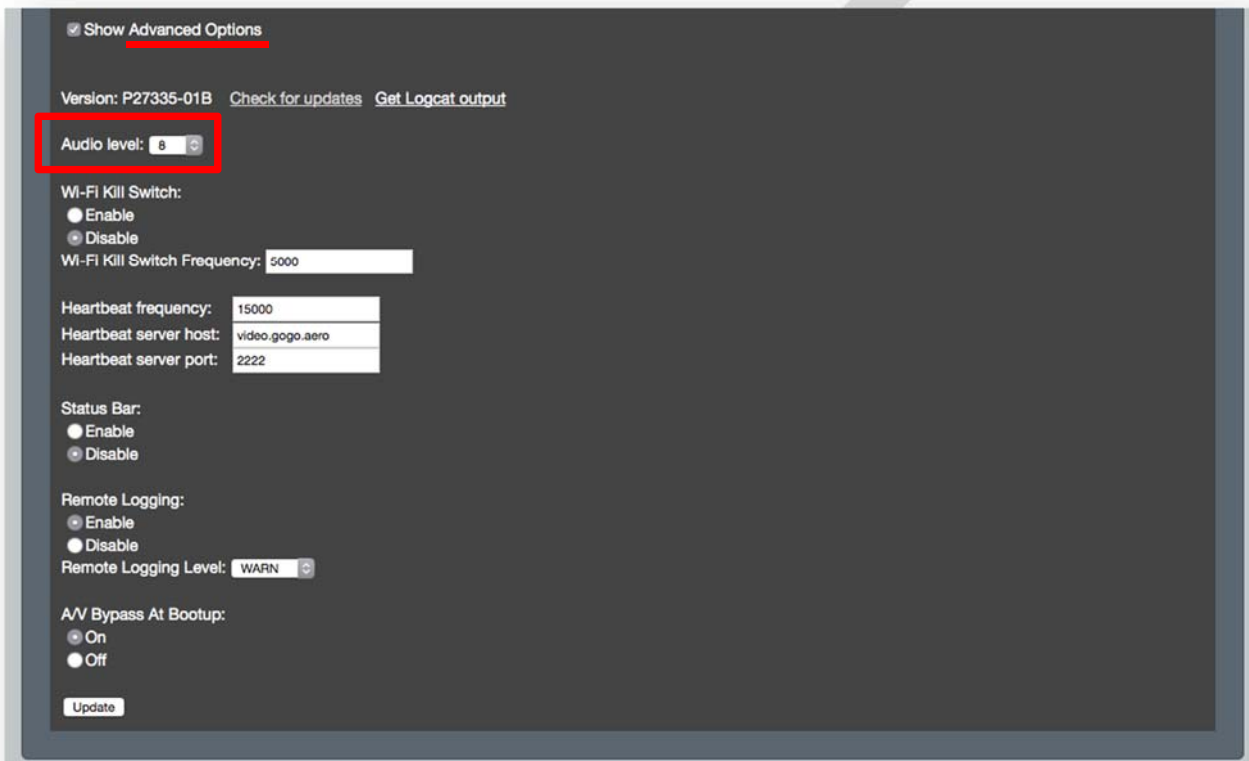

Figure 4.13. Audio Level

4.4.3.2. Wi-Fi Kill Switch:

The Wi-Fi Kill Switch parameter provides two radio buttons:

- Select **Enable** to allow proper functioning of the Wi-Fi kill switch wired to GPIO 1 or wired as part of a UCS installation.
- Select **Disable** to prevent any function of the Wi-Fi kill switch. Also select **Disable** when no Wi-Fi kill switch is incorporated into the system.

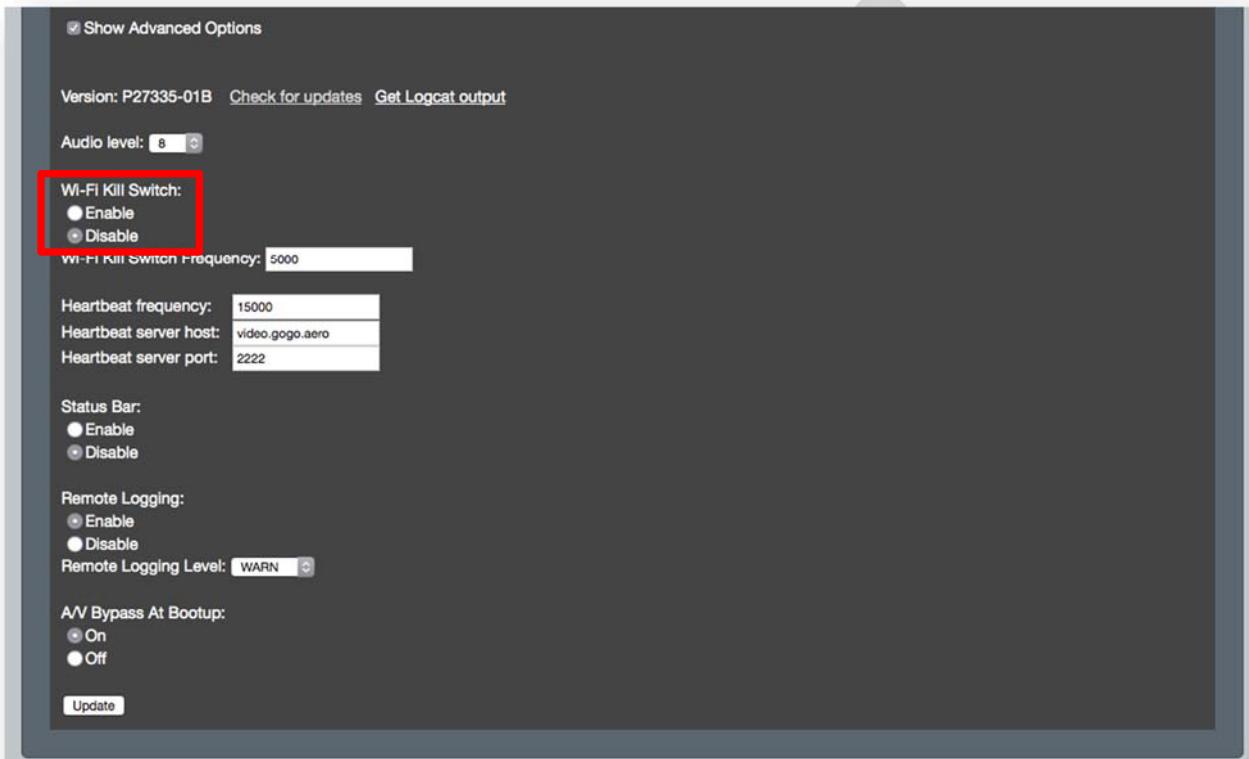

Figure 4.14. Wi-Fi Kill Switch

4.4.3.3. Wi-Fi Kill Switch Frequency:

Do not change this setting as it is intended for factory diagnostic purposes only

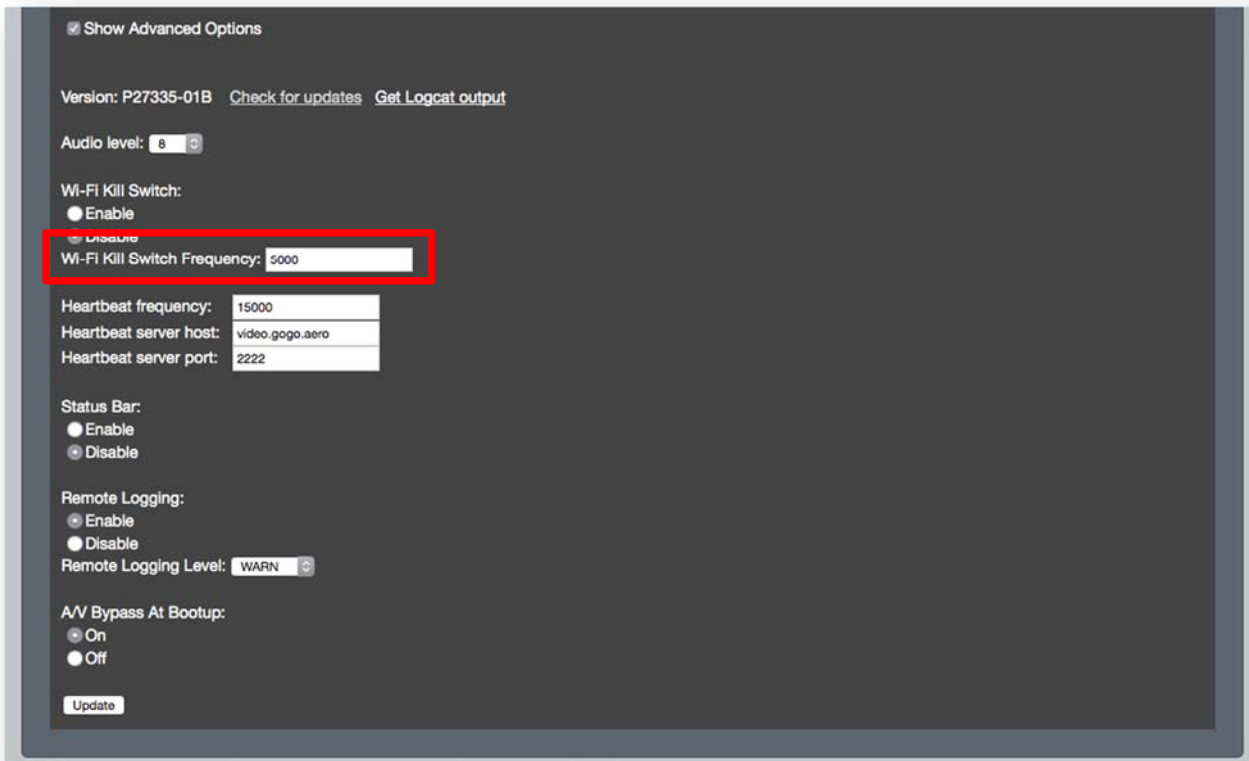

Figure 4.15. Wi-Fi Kill Switch Frequency

4.4.3.4. Heartbeat Frequency:

Do not change this setting as it is intended for factory diagnostic purposes only.

4.4.3.5. Heartbeat Server Host:

Do not change this setting as it is intended for factory diagnostic purposes only.

4.4.3.6. Heartbeat Server Port:

Do not change this setting as it is intended for factory diagnostic purposes only.

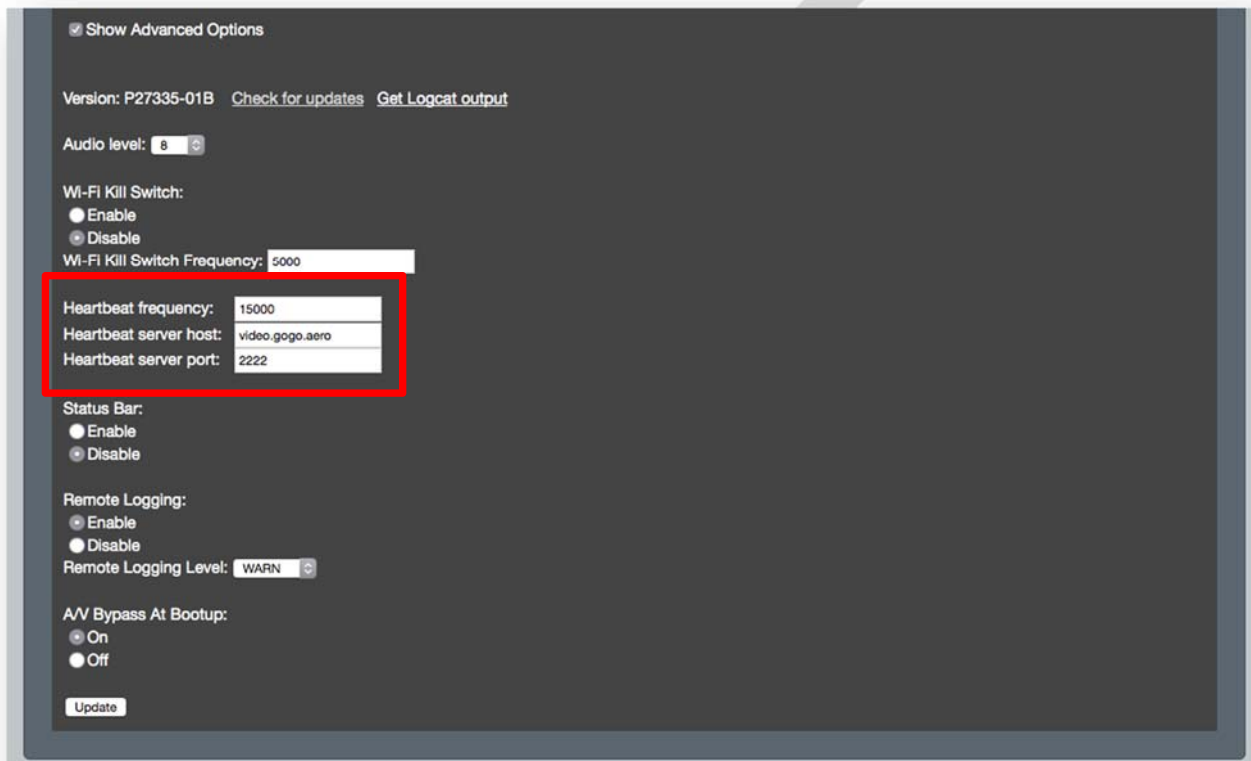

Figure 4.16. Heartbeat Frequency/Host/Port

4.4.3.7. Status Bar:

Do not change this setting as it is intended for factory diagnostic purposes only.

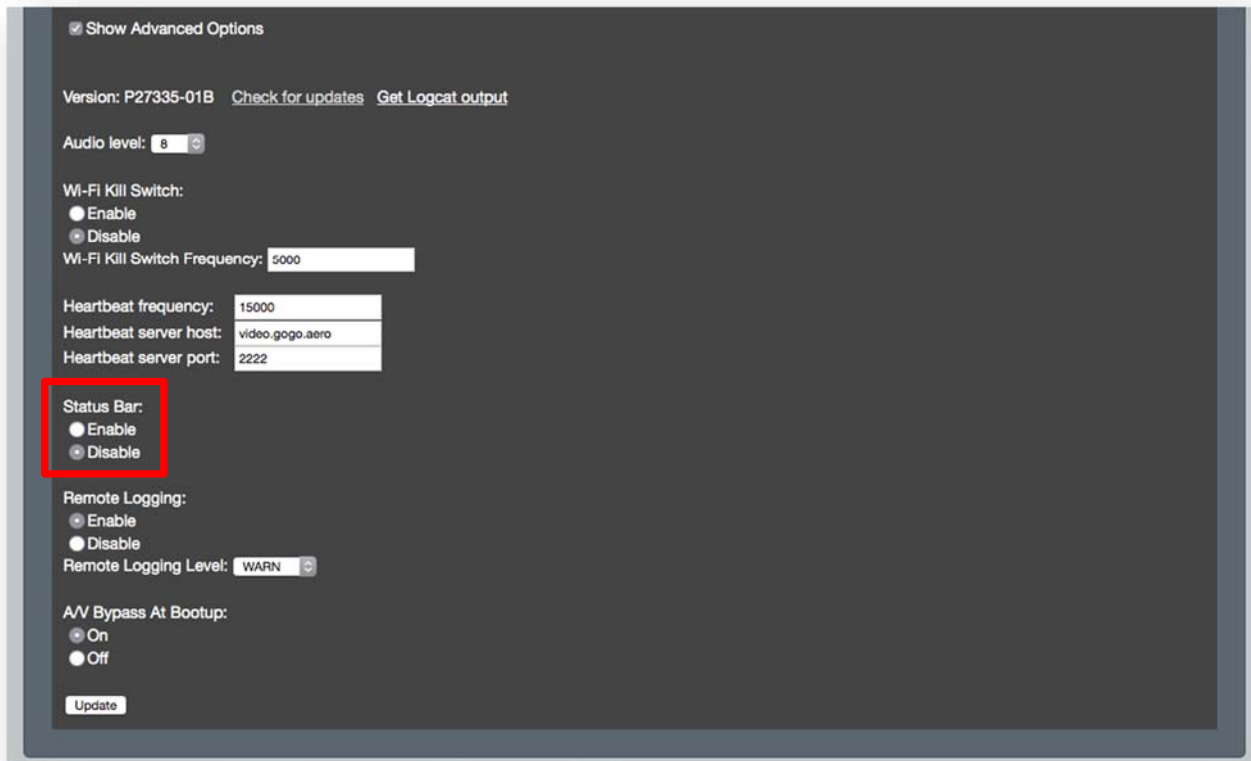

Figure 4.17. Status Bar



4.4.3.8. Remote Logging:

The Remote Logging at Bootup parameter provides two radio buttons:

- Select **Enable** to allow GVPV messages to be logged to the Vision/UCS server.
- Select **Disable** to prevent GVPV messages from being logged to the Vision/UCS server.

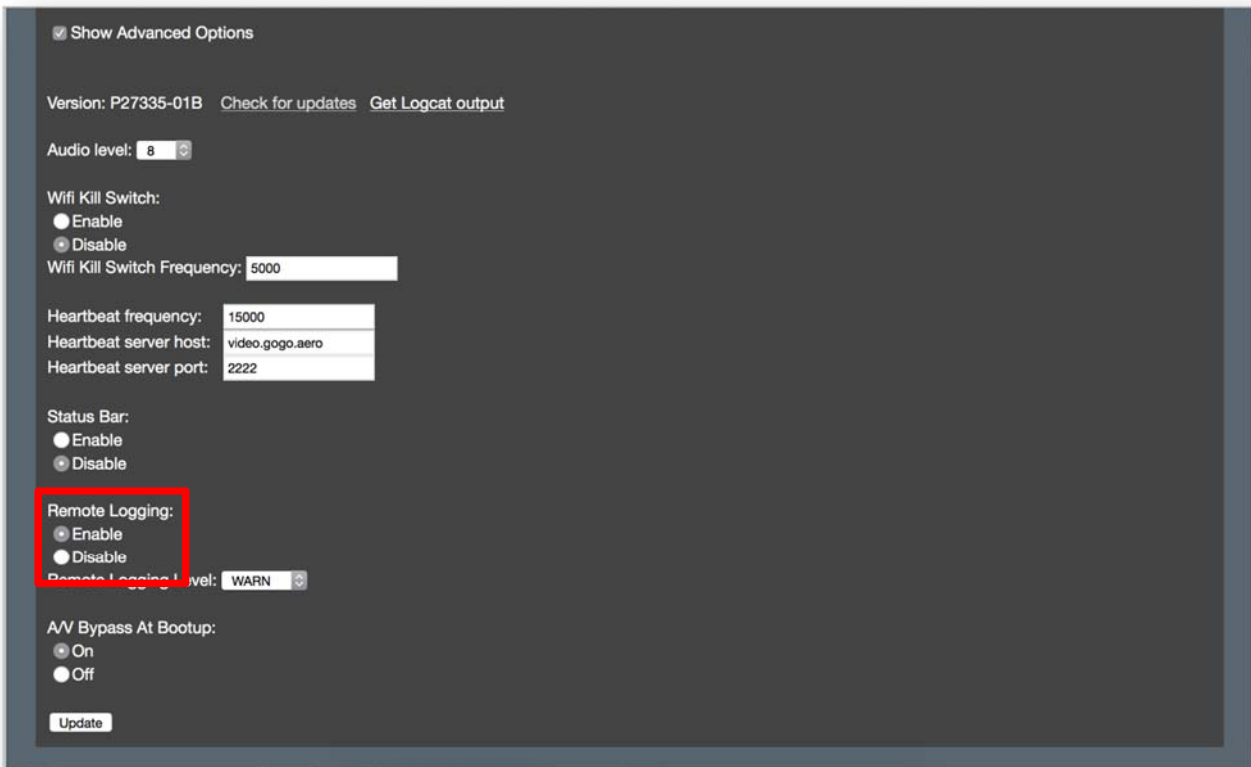

Figure 4.18. Remote Logging

4.4.3.9. Remote Logging Level:

Because Remote Logging creates extra network traffic, this level should be set to the highest level consistent with system functionality.

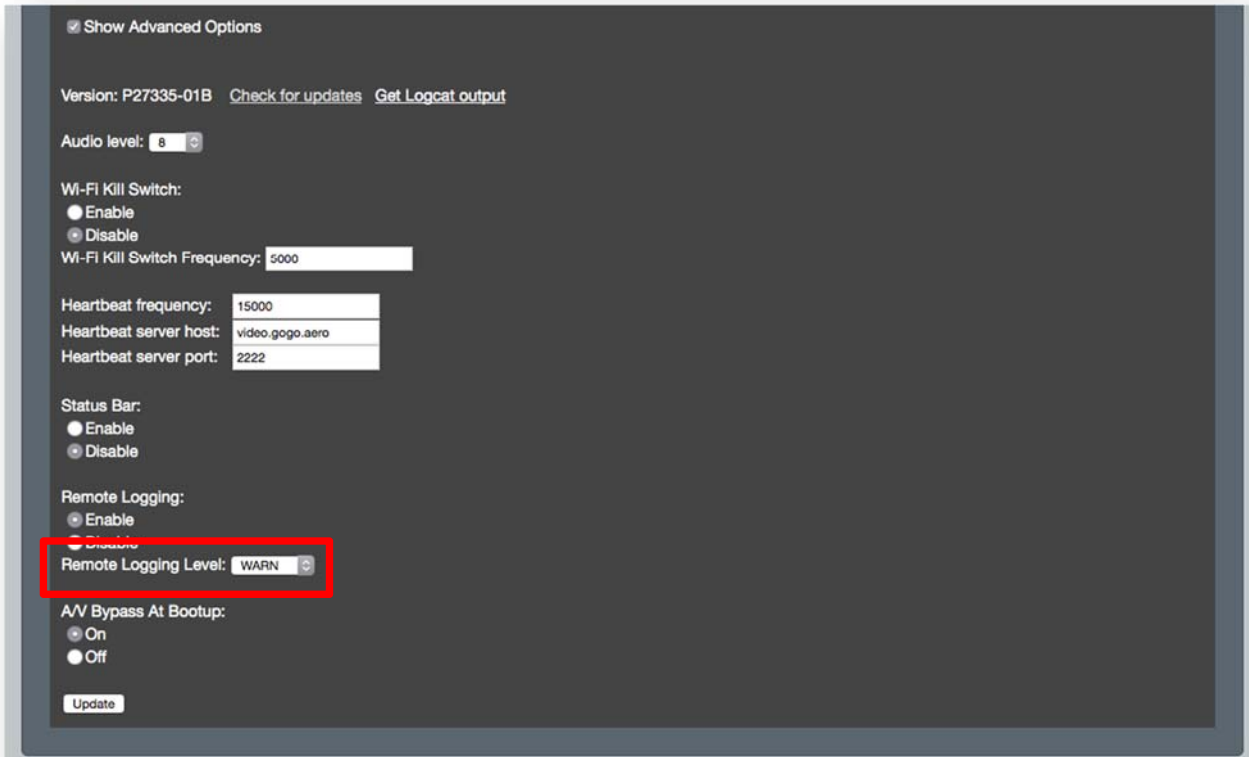

Figure 4.19. Remote Logging Level

4.4.3.10. A/V Bypass at Bootup:

The A/V Bypass at Bootup parameter provides two radio buttons:

- Select **On** to allow A/V to be turned on at bootup.
- Select **Off** to prevent A/V to be turned on at bootup.

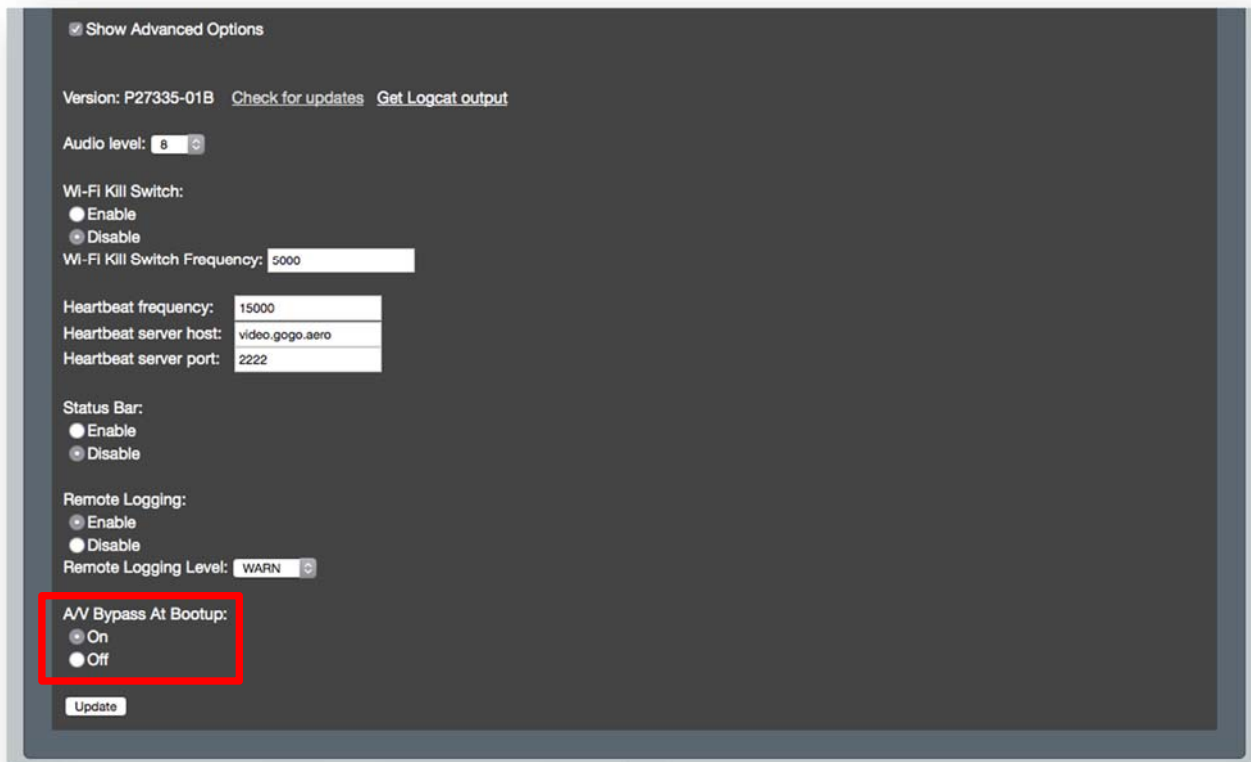

Figure 4.20. A/V Bypass at Bootup

4.4.3.11. Update

Press update to save changes.

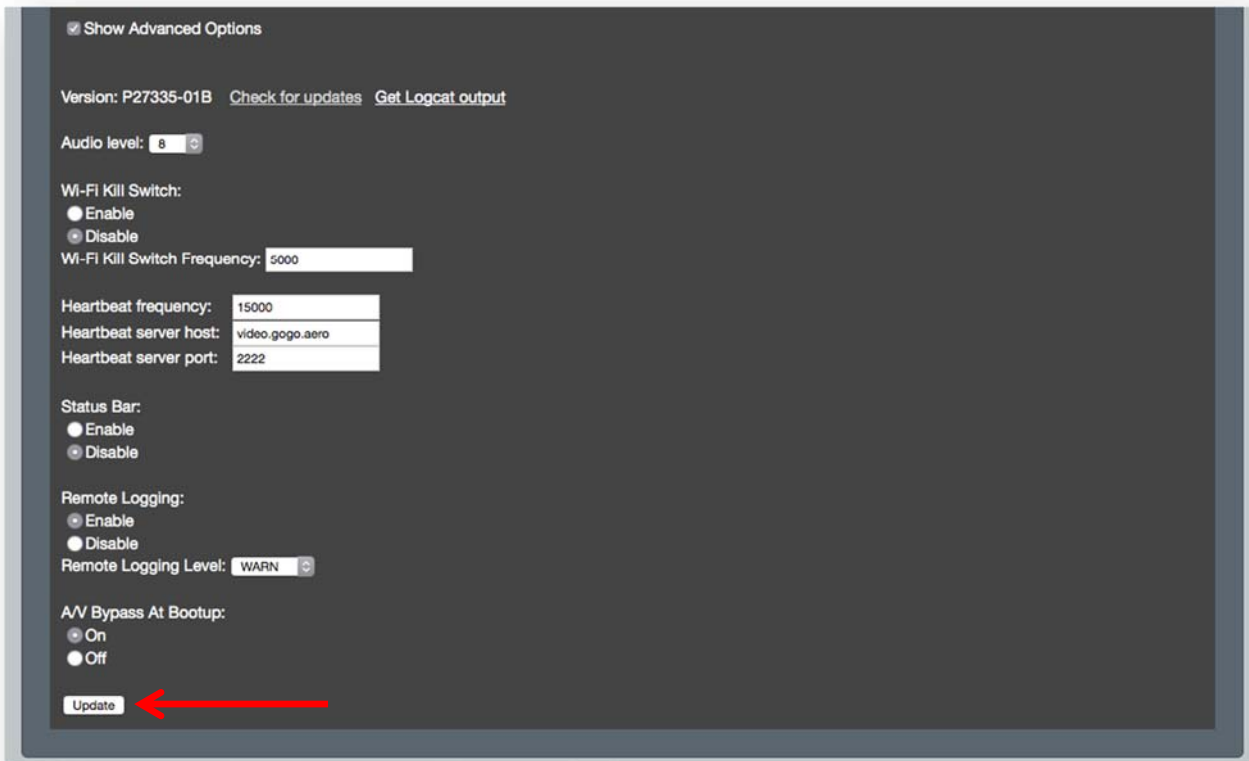

Figure 4.21. Update



4.5. Functional Testing

4.5.1. System Operational Checks

GVPU operation is dependent on system configuration. It is necessary to know the following parameters as they apply to the specific system being checked:

1. Monitor input: composite video or HDMI.
2. Video source(s): content server and/or composite video source.
3. Video input connection: hardwired Ethernet or Wi-Fi.
4. Audio source(s): content server for movies and/or other analog audio source.
5. Audio output: Analog RCA or S/PDIF.
6. IP address of the GVPU.

4.5.2. Required System Components

1. Known good monitor.
2. Known audio connection if installed.
3. Functional content server.
4. Functional external Internet connection to the content server for the DRM function.
5. Connected composite video source if installed.
6. Laptop computer (Windows 7 or higher and any Internet browser).

4.5.3. Operational Check: Configuration

1. Turn on power to the GVPU by closing applicable cabin monitor circuit breaker(s). Allow the system to boot up. Boot-up will be complete when the Configuration page can be accessed.
2. Set a static IP address on the laptop using the following steps:
 - a. Access the laptop's **Control Panel** and select **Network and Sharing Center**.
 - b. From the menu on the left side of the window, click on **Change Adapter Settings**
 - c. Right click on the laptop's **Local Area Connection** (names may vary) and then click **Properties** in the subsequent drop-down menu.
 - d. In the center table of the new window, click on **Internet Protocol Version 4 (TCP/IPv4)** and then click **Properties** when it is highlighted.
 - e. If it's not already highlighted, click the **Use the following IP address:** radio button. Enter the following IP addresses then click **OK**:
 - i. IP address: **172.20.10.XX**, where **XX** is between **11** and **99**.
 - ii. Subnet mask: **255.255.255.0**
 - iii. Default gateway: **172.20.10.2**
3. On the laptop, open an Internet browser and navigate to the GVPU IP address, **172.20.10.10**. Once the GVPU has booted up, the Configuration page will open which verifies the GVPU is receiving power.



4. On the Configuration page, configure the GVPV as follows:
 - a. If **Player Name** is not already populated, enter a name based on user preference.
 - b. Verify or set the **Connection Type** to **Ethernet**.
 - c. Click the **Wi-Fi Disable** radio button.
 - d. Verify or set **Audio Setting** to **Analog RCA**.
 - e. Verify or set **Video Setting** to **720P**.
 - f. Verify or set the **Audio Level** to **8**.
 - g. Verify or set the **Wi-Fi Kill Switch** to **Disable**.
 - h. Do not change the settings for the remaining parameters; **Heartbeat Frequency**, **Heartbeat Server Host**, and **Heartbeat Server Port**.
 - i. Click on the **Submit** button at the bottom of the page and wait for confirmation of changes.
5. Cycle (open then close) the cabin monitor circuit breaker and allow time for the GVPV to reboot. (Boot-up will be complete when the Configuration page can be accessed).
6. After reboot, access the Configuration page again.
7. Confirm the settings just made or change as necessary.
8. Click on the **Submit** button at the bottom of the page if needed and wait for confirmation of changes.

4.5.4. Operational Check: Streaming Video

Viewing a video from the content server requires the server to have access to the Internet. Ensure this is the case before trying to play a video.

1. Verify the cabin monitor is set for **HDMI Video** input using the monitor's remote control.
2. Start playing a video by typing the following label into the laptop browser:
<http://172.20.10.10:8080/player/video/start/AGCVFF0040>
3. Verify the video starts playing. (There may be a slight pause as the DRM function completes.)
4. Verify audio associated with the selected video is heard on the cabin speakers or on headphone jacks as appropriate.
5. Stop the video by typing the following label into the laptop browser:
<http://172.20.10.10:8080/player/video/stop>

4.5.5. Operational Check: Composite Video

1. On the laptop, access the Configuration page.
2. Set **Video Setting** to **CVBS** (for Composite video).
3. Click the **Submit** button at the bottom of the page and wait for confirmation of changes.
4. Insert a video tape into the player and set it to play.
5. Set the cabin monitor to **Composite Video** input using the monitor's remote control.
6. Verify video appears on the monitor.
7. Verify audio is heard on the cabin speakers or on the headphone(s) as appropriate.



8. Stop the video when check is complete.

4.6. Maintenance

4.6.1. Inspection

The GVPU installation shall be periodically inspected as required by Title 14 of the Code of Federal Regulations (14 CFR) Parts 43 and 91. The first inspection of the GVPU shall coincide with the first scheduled aircraft inspection after its installation. Inspection task intervals shall follow inspection interval tolerance guidance as outlined in the Aircraft Maintenance Manual (AMM). It is the responsibility of the operator to ensure that the maintenance and inspection technicians have access to this guide as well as the other previously noted documents.

The GVPU is to be maintained in an “on-condition” basis, however, it is recommended the system components and wiring be monitored for general condition and structural installation integrity during their respective area regular inspection intervals for the airframe. Consult the aircraft maintenance manual for inspection criteria for areas where system components are located.

4.6.2. Mandatory Replacement Time

The GVPU allows for “on-condition” maintenance meaning that no periodic service requirements are necessary to maintain continued airworthiness of the system. No maintenance is required until the equipment does not perform its intended function. If component replacement is warranted, contact Gogo Business Aviation Technical Support.



5.0 CLEANING

5.1. Introduction

The appearance of a completed installation is an important aspect of Customer satisfaction. Finger prints, smudges, wire clippings, and metal shavings should all be removed before the Customer inspects your work. Vacuum the affected area and clean the surrounding area completely.

5.2. Recommended Cleaning Materials

Mild soap and water for most plastics is recommended.

CAUTION

Use Isopropyl Alcohol carefully as it may react with some plastics in the area. Isopropyl Alcohol should be used to clean connector contacts and metal parts, if required.

5.3. Procedure

When Isopropyl Alcohol is used for the cleaning of system connectors, be sure to use a foam type Q-Tip to prevent the residue that can be left by a cotton Q-Tip.



This Page Intentionally Blank



6.0 FITS AND CLEARANCES

The attached sheets provide additional installation instructions for the GVPU. In addition to general notes, the attached sheets include the unit dimensional information, mounting provision dimensions, connector pin-out, and connector orientation diagrams.

NOTE

The Notes and Tables on these pages are very important; study them carefully.

6.1. GVPU

ICD D17113 Revision A, 3 pages 11x17 will follow this page.

DRAFT



This Page Intentionally Blank



7.0 SYSTEM SPECIFICATIONS

7.1. Purpose

This Section provides the specifications for the GVPU component along with mounting options.

7.2. Product Definition

The GVPU utilizes part number P24486.

7.3. Associated Reference Documents

RTCA/DO-160G, Environmental Conditions & Test Procedures for Airborne Equipment

7.4. Technical Specifications

7.4.1. GVPU

Dimensions

GVPU 3.23" W x 9.25" L x 1.33" H
(8.20 cm x 23.49 cm x 3.37 cm)

Weights (Not to Exceed)

GVPU 1.20 lb. (0.54 kg)

Power Requirements

7.5 W nominal at 28V
14 W maximum at 28V

Environmental (RTCA/DO-160G)

Temperature and Altitude..... Section 4, Category A4
Temperature Variation..... Section 5, Category C
Humidity..... Section 6, Category A
Shock and Crash Safety Section 7, Category B
Vibration..... Section 8, Category S (Curves C, L, M and Y)
Explosive Atmosphere Section 9, Category E
Waterproofness..... Section 10, Category Y
Sand & Dust..... Section 12, Category D
Fungus Section 13, Category F (By Analysis)
Magnetic Effect Section 15, Category Z
Power Input..... Section 16, Category A(X)
Voltage Spike..... Section 17, Category B
Audio Frequency Susceptibility..... Section 18, Category R
Induced Signal Susceptibility Section 19, Category ZC
Radio Frequency Susceptibility Section 20, Category T
Radio Frequency Emissions Section 21, Category M



Lightning Induced Susceptibility..... Section 22, Category A1 E1 L1
Electrostatic Discharge Section 25, Category A
Fire, Flammability..... Section 26, Category C

DRAFT



8.0 SPECIAL TOOLS, FIXTURES, AND EQUIPMENT

8.1. Introduction

No special tools are required for the installation of the GVPU.

8.2. GVPU Configuration using Ethernet Interface

- A notebook PC with a RJ-45 Ethernet connection port.
- A notebook PC with Wi-Fi capabilities when Wi-Fi connections are available through the GVPU or other Wireless Access Point (WAP)
- A Web browser installed (i.e., Internet Explorer)

No other special test equipment is required to determine the operational status of the GVPU.

Refer to Section 4.0 for the procedure to verify that the unit is serviceable.



This Page Intentionally Blank



9.0 PARTS LIST

9.1. Introduction

Refer to Section 7.0., System Specifications, for a list of important parts.

DRAFT



This Page Intentionally Blank



10.0 WIRING DIAGRAMS

10.1. Wiring Diagrams

The attached sheets provide additional installation instructions for the GVPU. In addition to general notes, the attached sheets include wiring diagrams for a typical GVPU installation.

The Notes and Tables on these pages are very important. Study them carefully.

10.2. GVPU

Wiring Instructions D----- Revision A, xx pages 11x17 will follow this page.

DRAFT



This Page Intentionally Blank



Troubleshooting Procedures

For GVPU malfunctions, consult Gogo Business Aviation Technical Support to help evaluate any problem that is not resolved by standard troubleshooting techniques captured in this manual. Many issues are resolved with a power cycle of the unit.

The Gogo Business Aviation Technical Support Group can be contacted by phone at 303-301-3278 or through email at Techsupport-CO@gogoair.com. After any repair or replacement of system components, perform an operational check of the system. Refer to Section 4 for post-installation tests.

GVPU Peripheral Equipment Troubleshooting

Troubleshooting this equipment should only be accomplished by FAA-approved Repair Stations with the appropriate ratings, or appropriately rated operators/individuals, with required test equipment and service data. System function should be determined through review of test and troubleshooting procedures outlined in the latest version of this manual. Once the system's operation has been diagnosed as described above, correction of the fault should be accomplished by replacing the defective component or correction of the determined wiring/power fault that is causing the fault.

GVPU Fault Identification

In the event of a fault, the following can be used for common diagnostics.

Unit Fails to Output Video

1. Gain access to the GVPU by removing four fasteners holding the media module in place and pull it forward. Support the module so it does not fall forward and hang on the wiring.
2. Connect a laptop (Windows 7 Operating System or higher with any Internet browser) to the GVPU via Ethernet using one of the following methods:
 - a. If the Ethernet jack, JB1, on the GVPU is available, connect it to the laptop's RJ-45 Ethernet port with a standard Ethernet cable.
 - b. If the Ethernet jack, JB1, is not available, connect the laptop's RJ-45 Ethernet port using a standard Ethernet cable to the maintenance Ethernet jack.
3. Set a static IP address on the laptop using the following steps:
 - a. Access the laptop's Control Panel and select **Network and Sharing Center**.
 - b. From the menu on the left side of the window, click on **Change Adapter Settings**.
 - c. Right click on the laptop's **Local Area Connection** (names may vary) and then click **Properties** in the subsequent drop-down menu.
 - d. In the center table of the new window, click on **Internet Protocol Version 4 (TCP/IPv4)** and then click **Properties** when it is highlighted



- e. If it's not already highlighted, click the **Use the following IP Address:** radio button. Enter the following IP addresses then click **OK**:
 - i. IP address: **172.20.10.XX**, where **XX** is between **11** and **99**.
 - ii. Subnet mask: **255.255.255.0**
 - iii. Default gateway: **172.20.10.2**

On the laptop, open an Internet browser and navigate to the GVPU IP address, **172.20.10.10**. The GVPU Configuration page will open which verifies the GVPU is receiving power.

4. Pull the applicable cabin monitor circuit breaker(s) located on the circuit breaker panel.
5. On the GVPU, disconnect the connector from J8.
6. Verify that all sockets on the connector are seated correctly and free of impediments. Verify that no pins on the J8 connector are bent.
7. On the GVPU, reconnect connector to J8.
8. On the GVPU, verify security of the DVI connector (if used) at J2.
9. On the GVPU, disconnect the connector from J7.
10. Verify that all sockets on the connector are seated correctly and free of impediments. Verify that no pins on the J7 connector are bent.
11. Reset the cabin monitor circuit breaker(s) located on the circuit breaker panel.
12. Using a DC voltmeter able to measure above 28 VDC, verify that 28VDC \pm 4VDC exists at J7 between pin 19 (+28 VDC) and pin 37 (Return).
13. Pull the cabin monitor circuit breaker located on the aft circuit breaker panel.
14. On the GVPU, reconnect connector to J7.
15. Reset the cabin monitor circuit breaker(s).
16. When the GVPU has booted up, use the laptop browser to access the GVPU Configuration page (IP address **172.20.10.10**). Boot-up will be complete when the Configuration page can be accessed.
17. Set up the following configuration parameters:
 - a. Connection Type: **Ethernet**
 - b. Wi-Fi: **Disable**
 - c. Audio Setting: **Analog RCA**
 - d. Video Setting: **Composite**
18. Click the **Submit** button at the bottom of the screen and wait for acknowledgement that settings have been accepted.
19. Verify the cabin monitor is set for **Composite Video** input using the monitor's remote control.
20. Verify the player has a VHS tape in it and set it to play.
21. Verify the GVPU displays the composite video on the cabin monitor.
22. Upon verifying performance, turn off all equipment, push the media module back in place and secure with fasteners.

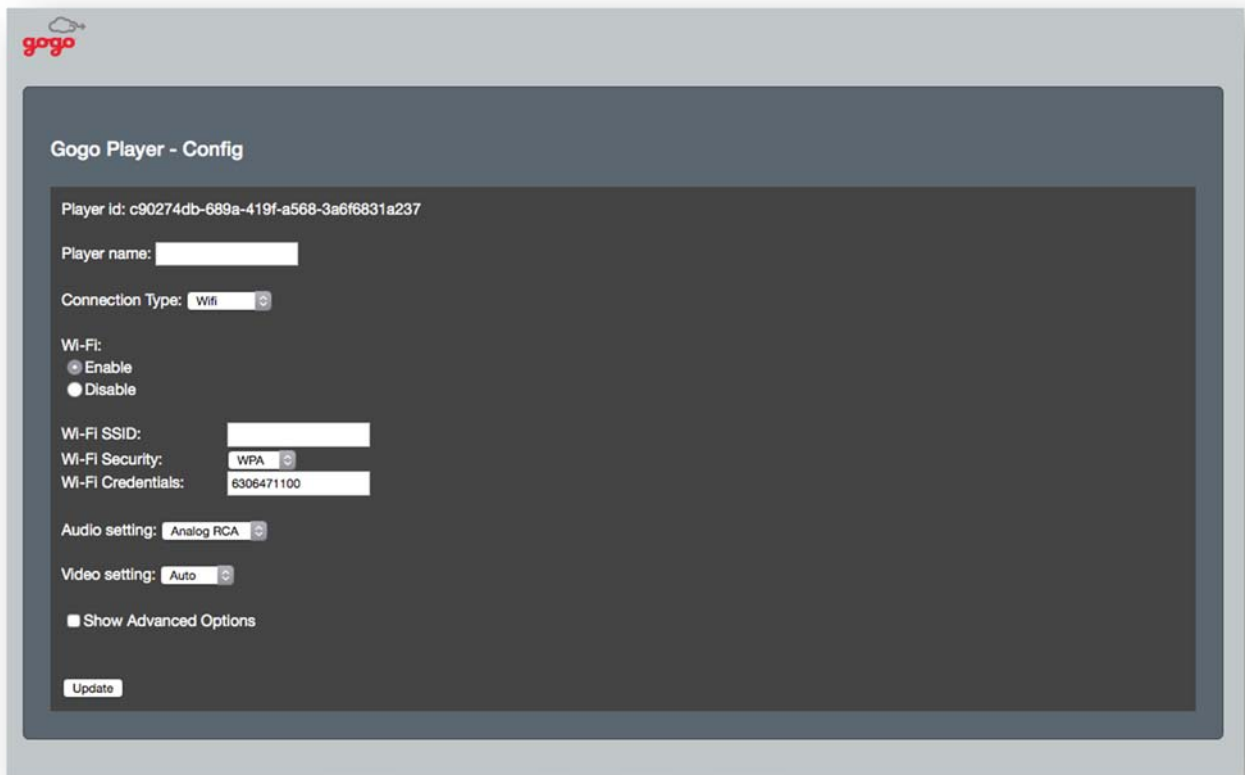

Figure A-1 GVPU Configuration Page

Unit Fails to Output Analog Audio

1. Gain access to the GVPU by removing four fasteners holding the media module in place and pull it forward. Support the module so it does not fall forward and hang on the wiring.
2. Connect a laptop (Windows 7 Operating System or higher with any Internet browser) to the GVPU via Ethernet using one of the following methods.
 - a. If the Ethernet jack, JB1, on the GVPU is available, connect it to the laptop's RJ-45 Ethernet port with a standard Ethernet cable.
 - b. If the Ethernet jack, JB1, is not available, connect the laptop's RJ-45 Ethernet port using a standard Ethernet cable to the maintenance Ethernet jack.
3. Set a static IP address on the laptop using the following steps:
 - a. Access the laptop's **Control Panel** and select **Network and Sharing Center**.
 - b. From the menu on the left side of the window, click on **Change Adapter Settings**.
 - c. Right click on the laptop's **Local Area Connection** (names may vary) and then click **Properties** in the subsequent drop-down menu.



- d. In the center table of the new window, click on **Internet Protocol Version 4 (TCP/IPv4)** and then click **Properties** when it is highlighted.
- e. If it's not already highlighted, click the **Use the following IP Address:** radio button. Enter the following IP addresses then click **OK**:
 - i. IP address: **172.20.10.XX**, where **XX** is between **11** and **99**.
 - ii. Subnet mask: **255.255.255.0**
 - iii. Default gateway: **172.20.10.2**
4. On the laptop, open an Internet browser and navigate to the GVPU IP address, **172.20.10.10**. The GVPU Configuration page will open which verifies the GVPU is receiving power.
5. With the Configuration page open, verify **Audio Setting** is set to **Analog RCA**. If needed, change the setting to **Analog RCA** and then click the **Submit** button at the bottom of the screen. Wait for the Configuration page to indicate settings have been saved.
6. Pull the cabin monitor circuit breaker(s)
7. On the GVPU, disconnect the connector from J7.
8. Verify that all sockets on the connector are seated correctly and free of impediments. Verify that no pins on the J7 connector are bent.
9. Reset the cabin monitor circuit breaker(s).
10. When the GVPU has booted up, use the laptop browser to access the GVPU Configuration page (IP address **172.20.10.10**). Boot-up will be complete when the Configuration page can be accessed
11. Set up the following configuration parameters:
 - a. Connection Type: **Ethernet**
 - b. Wi-Fi: **Disable**
 - c. Audio Setting: **Analog RCA**
 - d. Video Setting: **Composite**
12. Click the **Submit** button at the bottom of the screen and wait for acknowledgement that settings have been accepted.
13. Verify the cabin monitor is set for **Composite Video** input using the monitor's remote control.
14. Using a DC voltmeter able to measure above 28 VDC, verify that 28VDC \pm 4VDC exists at J7 between pin 19 (+28 VDC) and pin 37 (Return).
15. Verify the player has a VHS tape in it and set it to play.
16. With a tape playing, connect an AC voltmeter set to a low range across pins 16 & 35 (Audio Pass-through Right channel) of the J7 connector and verify the presence of an audio signal indicated by a variable AC voltage between approximately 10 and 100 mV RMS.
17. With a tape still playing, connect the AC voltmeter across pins 17 & 35 (Audio Pass-through Left channel) of the J7 connector and verify the presence of an audio signal indicated by a variable AC voltage between approximately 10 and 100 mV RMS.
18. Pull the cabin monitor circuit breaker(s).
19. On the GVPU, reconnect the connector to J7.



20. Reset the cabin monitor circuit breaker(s).
21. With the tape still playing, verify the presence of the soundtrack on the cabin speakers or headphone(s) indicating the GVPU is able to output analog.
22. Upon verifying performance, turn off all equipment, push the media module back in place and secure with fasteners.

Contact Gogo Business Aviation Technical Support for help in evaluating any problem not resolved by these troubleshooting procedures. Gogo Business Aviation Technical support can be contacted by email at batechsupport@gogoair.com or, for immediate needs, by telephone at +1-303-301-3278. After any repair or replacement of a system component, perform an operational check as described in section 4 of this document.

DRAFT



This Page Intentionally Blank



Instructions for Continued Airworthiness

Design and manufacturing of the GVPU allows for “**On Condition Maintenance.**” On condition maintenance means that no periodic service requirements are required to maintain continued airworthiness of the system. No maintenance is required until the equipment does not perform the intended function. Cable harness repair, RF cable maintenance, and antenna replacement can be accomplished in the field. Refer to Appendix A for detailed information on troubleshooting procedures. **Any alteration of this product voids the FAA or Federal Communications Commission (FCC) certification and the Gogo Business Aviation warranty.** Please consult Gogo Business Aviation Technical Support to help evaluate any problem that is not resolved by following the troubleshooting procedures in Appendix A. A Return Material Authorization (RMA) is required for all repairs or exchanges on items returned to Gogo Business Aviation. After obtaining an RMA, return the GVPU to the factory for repair. If you require an exchange unit to maintain telecommunications operation during Gogo Business Aviation repairs, please call Customer Service and request that a serviceable unit be sent to you before removing the installed unit. After factory repair or receiving the serviceable component, consult this Installation Manual (D18340), Setup and Configuration, to verify proper system operation in the aircraft. If component is a GVPU, be sure to configure the replacement serviceable unit (call Customer Service @ 1-888-286-9876) to verify activation of this unit.



This Page Intentionally Blank