



## FCC Part 11 Subpart B TEST REPORT

Report Number: 100137947BOX-006

Project Number: G100137947

Report Issue Date: 08/25/2010

Product Designation: PAC

Standards: CFR47 Telecommunications  
Part 11 "Emergency Alert System (EAS)" Subpart B

Tested by:  
Intertek Testing Services NA, Inc.  
70 Codman Hill Road  
Boxborough, MA 01719

Client:  
Comlabs  
750 North Drive  
Melbourne, 32934

Report prepared by

Nicholas Abbondante  
Sr. Project Engineer

Report reviewed by

Michael F. Murphy  
Staff Engineer, EMC

*This report is for the exclusive use of Intertek's Client and is provided pursuant to the agreement between Intertek and its Client. Intertek's responsibility and liability are limited to the terms and conditions of the agreement. Intertek assumes no liability to any party, other than to the Client in accordance with the agreement, for any loss, expense or damage occasioned by the use of this report. Only the Client is authorized to permit copying or distribution of this report and then only in its entirety. Any use of the Intertek name or one of its marks for the sale or advertisement of the tested material, product or service must first be approved in writing by Intertek. The observations and test results in this report are relevant only to the sample tested. This report by itself does not imply that the material, product, or service is or has ever been under an Intertek certification program.*

## 1 Introduction and Conclusion

The tests indicated in section 2.0 were performed on the product constructed as described in section 3.0. The remaining test sections are the verbatim text from the actual data sheets used during the investigation. These test sections include the test name, the specified test Method, a list of the actual Test Equipment Used, documentation Photos, Results and raw Data. No additions, deviations, or exclusions have been made from the standard(s) unless specifically noted.

Based on the results of our investigation, we have concluded the product tested **complies** with the requirements of the standard(s) indicated. The results obtained in this test report pertain only to the item(s) tested.

## 2 Test Summary

Section	Test full name	Result
3	Client Information	--
4	Description of Equipment Under Test	--
5	System setup including cable interconnection details, support Equipment and simplified block diagram	--
--	Radiated Emissions FCC 15.109 – Emissions must be below the 15.109 Class A limits	Not tested by Intertek
--	AC Line-Conducted Emissions FCC 15.107 – Emissions must be below the 15.107 Class A limits	Not tested by Intertek
6	EAS Protocol FCC 11.31 – The EAS protocol must meet the protocol requirements of 11.31. See Test Details for a detailed list of requirements.	Pass
7	EAS Encoder FCC 11.32 – The EAS encoder must meet the operational requirements of 11.32. See Test Details for a detailed list of requirements.	Pass
8	EAS Decoder FCC 11.33 – The EAS decoder must meet the operational requirements of 11.33. See Test Details for a detailed list of requirements.	Pass
9	Revision History	--

**3 Client Information**

This EUT was tested at the request of:

**Company:** Comlabs  
750 North Drive  
Melbourne, 32934

**Contact:** Jared Maynard  
**Telephone:** (321) 409-9898 Ext. 305  
**Fax:** (321) 409-9899  
**Email:** j.maynard@comlabs.com

**4 Description of Equipment Under Test**

Equipment Under Test			
Description	Manufacturer	Model Number	Serial Number
Emergency Alert System	Comlabs	PAC	Computer-BOX1007121343-013

Receive Date:	07/12/2010
Received Condition:	Good
Type:	Production

Description of Equipment Under Test (provided by client)

Emergency Alert System

Equipment Under Test Power Configuration			
Rated Voltage	Rated Current	Rated Frequency	Number of Phases
120V/230V	8A/4A	50/60Hz	Single

**Operating modes of the EUT:**

No.	Descriptions of EUT Exercising
1	11.32(b), (c), and (d) – The EUT was operating in Encoding/Decoding/Processing loop
2	All other tests – The EUT was operating in its normal operation

**5 System setup including cable interconnection details, support equipment and simplified block diagram**

**5.1 Method:**

Record the details of EUT cabling, document the support equipment, and show the interconnections in a block diagram.

**5.2 EUT Block Diagram:**

**Support Transmitter Setup**

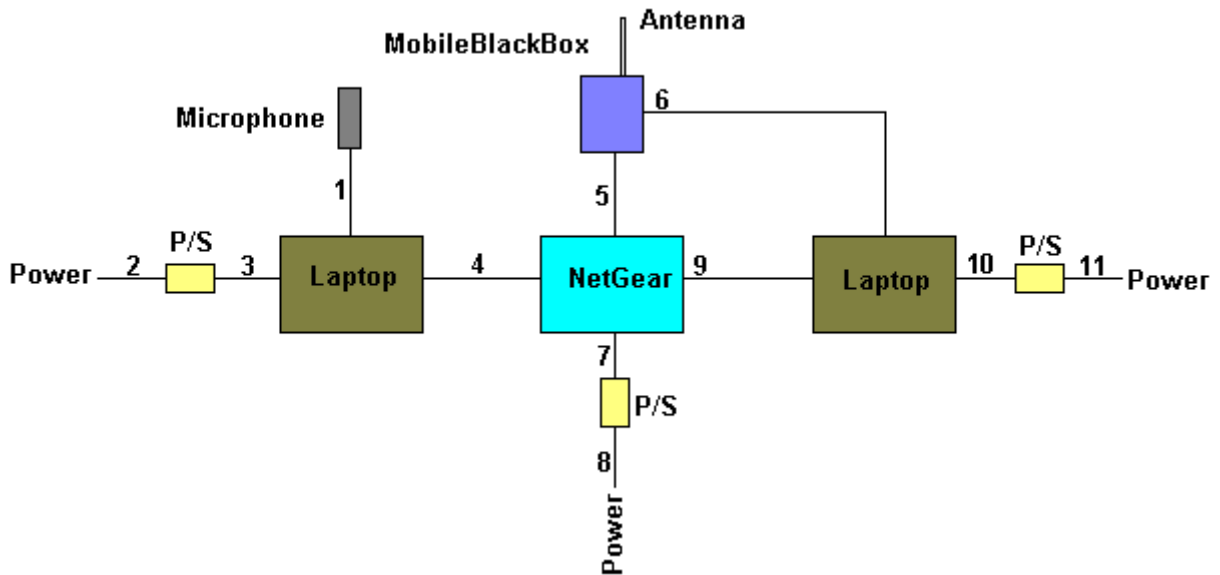

**EUT Setup**

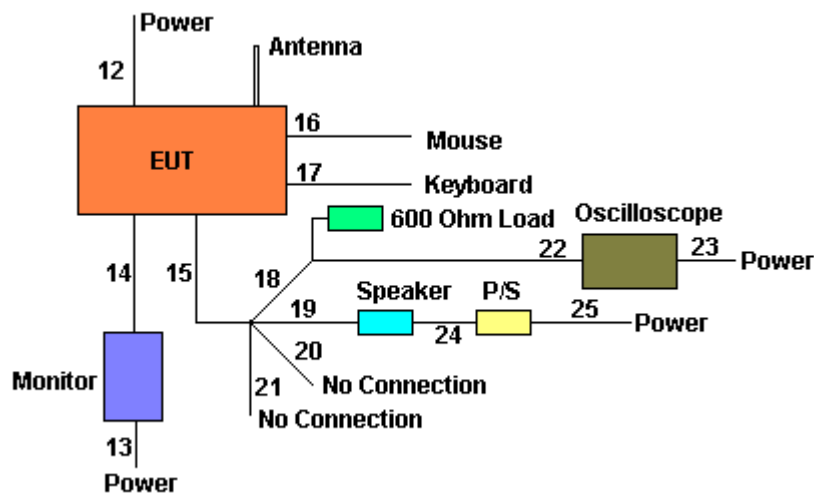

**5.3 Cables:**

ID	Description	Length	Shielding	Ferrites
1	Microphone	~2m	Braid	None
2	AC	~2m	None	None
3	AC Adapter	~2m	None	None
4	RJ45	~0.5m	None	None
5	RJ45	~2m	None	None
6	USB	~2m	Braid	One on both ends
7	AC Adapter	~2m	None	None
8	AC	~2m	None	None
9	RJ45	~3m	None	None
10	AC Adapter	~2m	None	None
11	AC	~2m	None	None
12	AC	~1m	None	None
13	AC	~1m	None	None
14	Video	~1m	Braid	One on both ends
15	DB9	~0.25m	Braid	None
16	Mouse	~1m	None	None
17	Keyboard	~1m	None	None
18	Load	~2m	None	None
19	Speaker	~2m	None	None
20	DIN	~2m	None	None
21	DIN	~2m	None	None
22	Coaxial	~1m	Coaxial	None
23	AC	~2m	None	None
24	AC Adapter	~2m	None	None
25	AC	~2m	None	None

**5.4 Support Equipment:**

Support Equipment			
Description	Manufacturer	Model Number	Serial Number
Fast Ethernet Switch	NetGear	FS116	FS11236LB095255
Microphone	Audio-technica	AT2020USB	None
FM Audio Transmitter	MobileBlackBox	V6000	None
Speaker	Altec Lansing Multimedia	FM40043604	None
Laptop	Toshiba	PN PSAE3U-06Y023	38354111K
Laptop	Toshiba	PN PSAE3U-06Y023	38353990K
Monitor	Dell	E173FPc	CN-OF5035-64180-58K-2EHC
Mouse	Dell	M-SAW34	LZC33565267
Keyboard	Microsoft	RT9480	6968200598410
Laptop P/S	Toshiba	ADP-75SB AB	U8261
Laptop P/S	Toshiba	ADP-75SB AB	U5697
NetGear P/S	NetGear	PWR-002-004	None
Speaker P/S	HoMedics	ADP-10(D12-2000)	None

## 6 EAS Protocol

### 6.1 Method

Tests are performed in accordance with FCC Part 11.31

**TEST SITE:** EMC Lab

**The EMC Lab** has two Semi-anechoic Chambers and one Shielded Chamber. AC Mains Power is available at 120, 230, and 277 Single Phase; 208, 400, and 480 3-Phase. Large reference ground-planes are installed in the general lab area to facilitate EMC work not requiring a shielded environment.

**The AMAP Building and Lab** includes general lab space that can be used for testing where a shielded/enclosed environment is not required.

### 6.2 Test Equipment Used:

Asset	Description	Manufacturer	Model	Serial	Cal Date	Cal Due
DAV001	Weather Station	Davis Instruments	7400	PE80519A61	06/11/2010	06/11/2011
TEK4	Oscilloscope, Digital Storage	Tektronix	TDS3052	B014809	10/29/2009	10/29/2010

#### Software Utilized:

Name	Manufacturer	Version
None		

### 6.3 Results:

The sample tested was found to comply.

6.4 Setup Photographs:



**6.5 Data:**

*11.31(a)(1): The Preamble and EAS Codes must use Audio Frequency Shift Keying at a rate of 520.83 bits per second to transmit the codes. Mark frequency is 2083.3 Hz and space frequency is 1562.5 Hz. Mark and space time must be 1.92 milliseconds. Characters are ASCII seven bit characters as defined in ANSI X3.4-1977 ending with an eighth null bit (either 0 or 1) to constitute a full eight-bit byte.*

The output of the PAC was connected to the input of the TDS 3052 oscilloscope as shown in the EUT block diagram and plots of the bit length at each frequency were recorded.



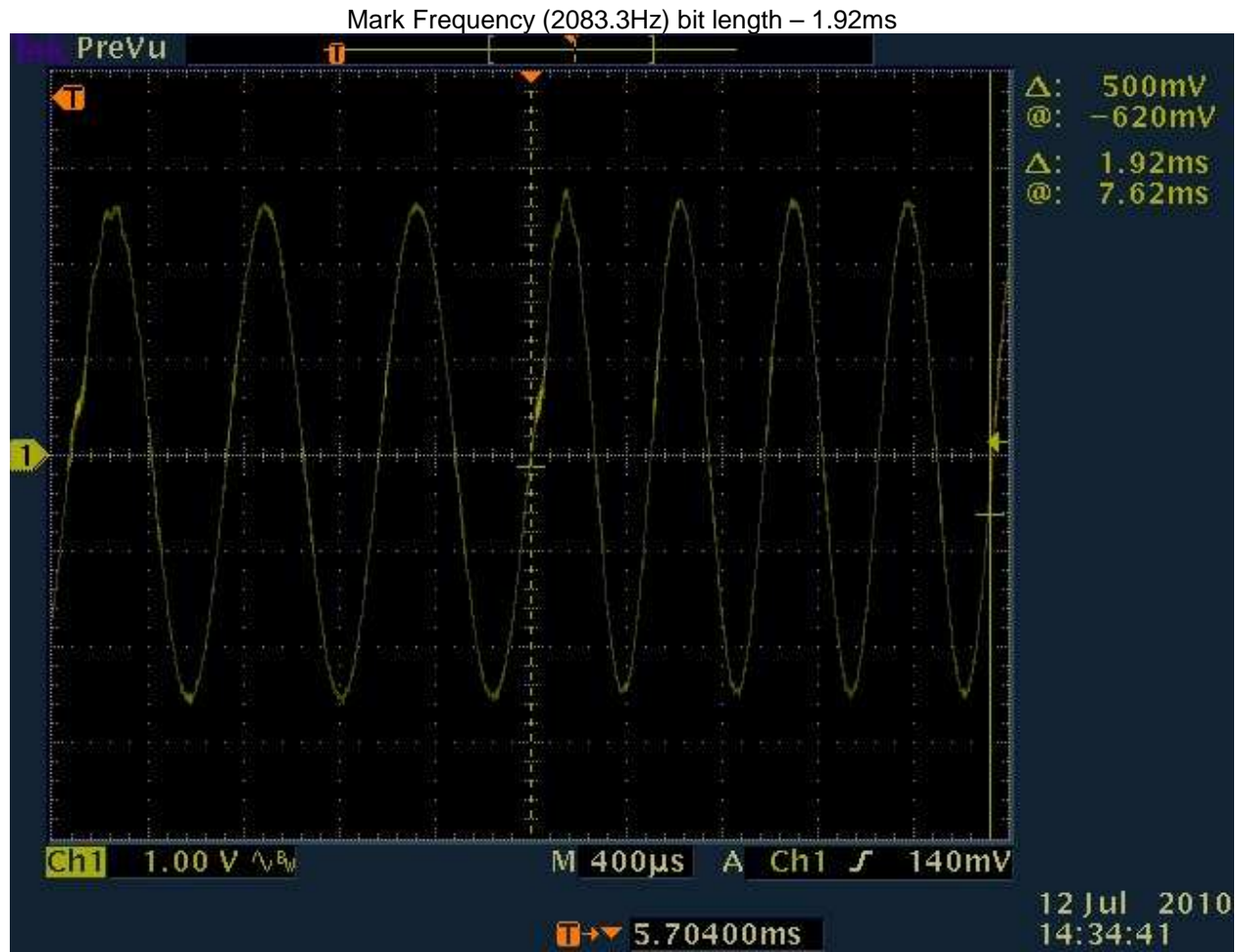

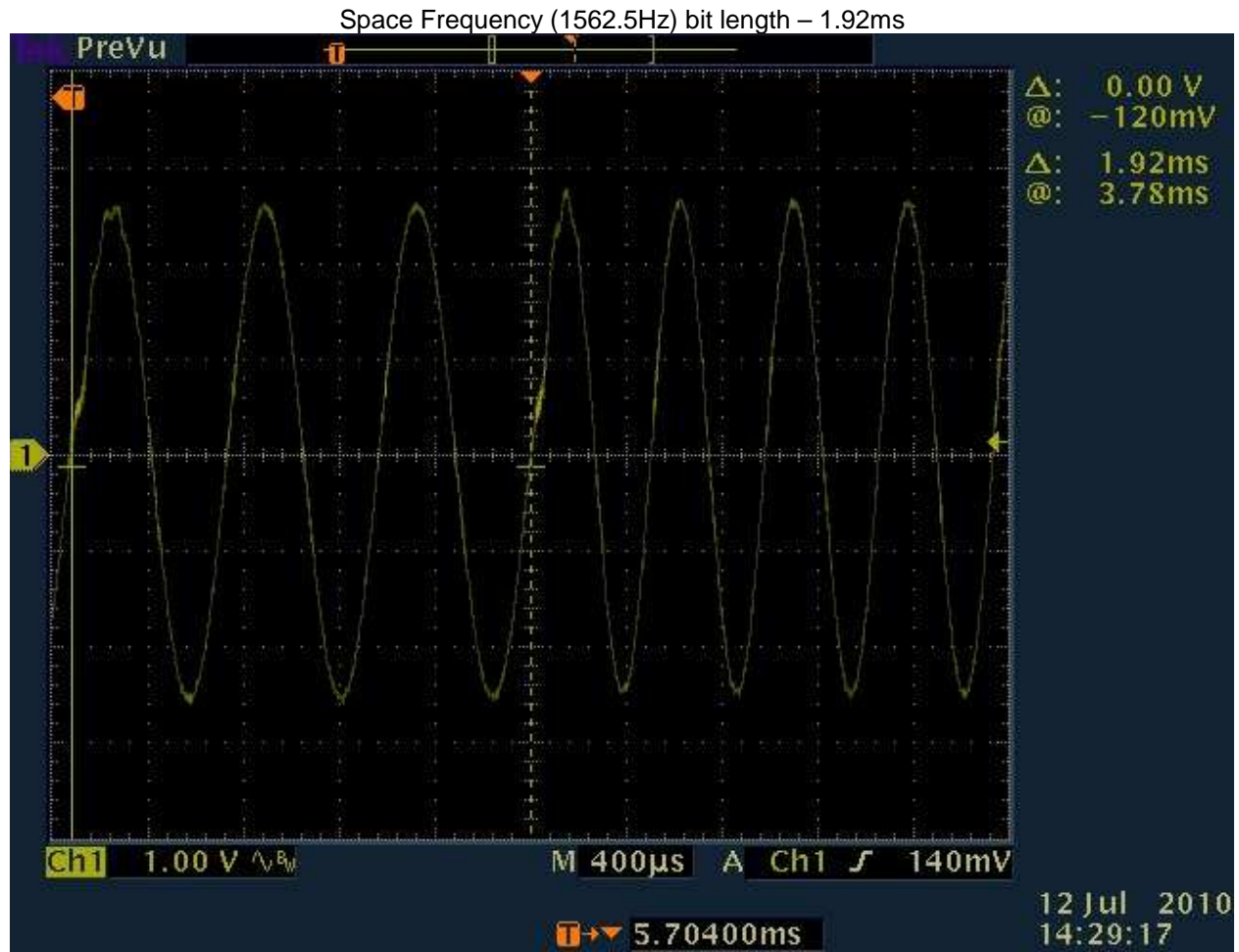

*11.31(a)(2): The Attention Signal must be made up of the fundamental frequencies of 853 and 960 Hz. The two tones must be transmitted simultaneously. The Attention Signal must be transmitted after the EAS header codes.*

The output of the PAC was connected to the input of the TDS 3052 oscilloscope as shown in the EUT block diagram and plots of the bit length at each frequency were recorded.

The two tones, 853 and 960 Hz, transmitted simultaneously

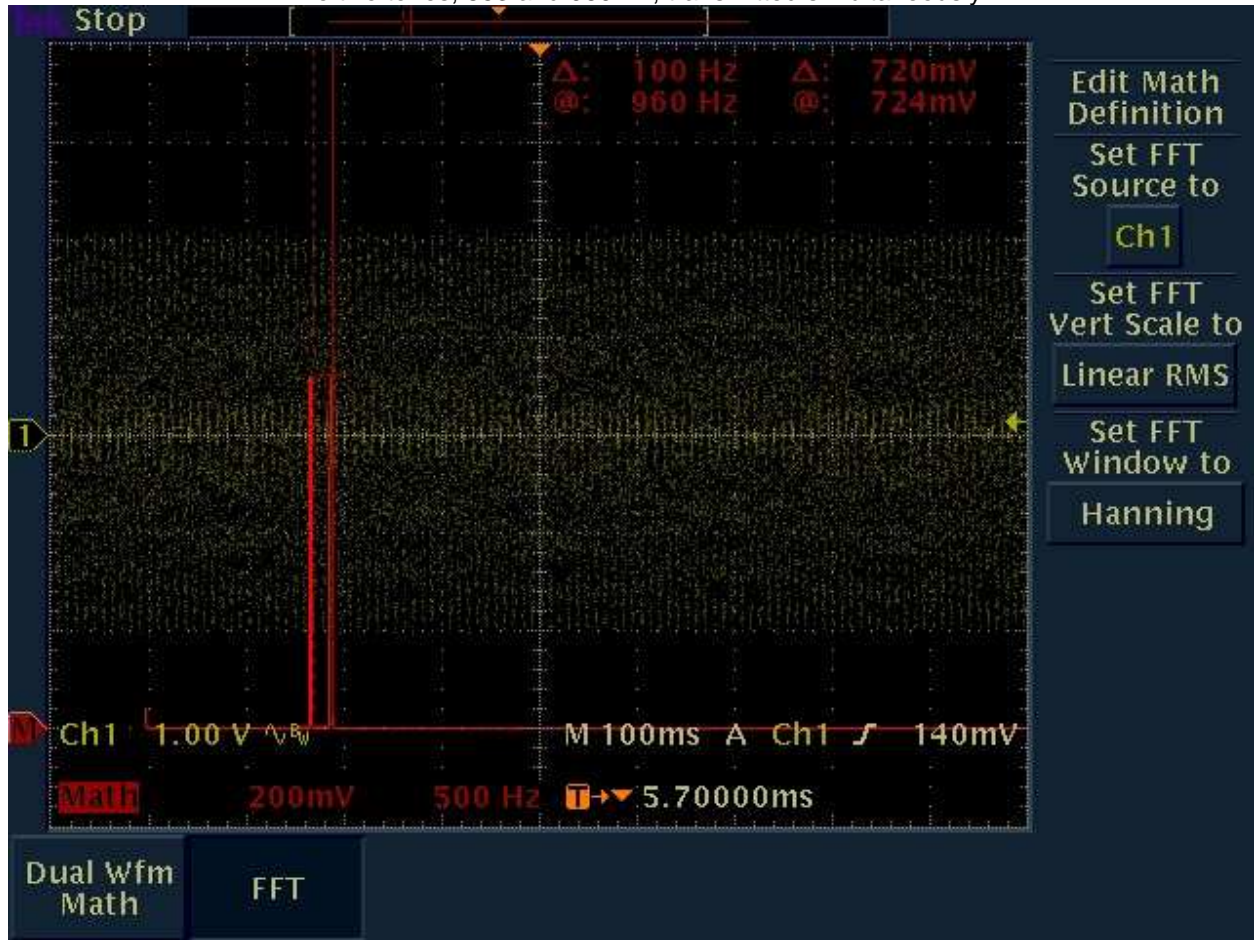

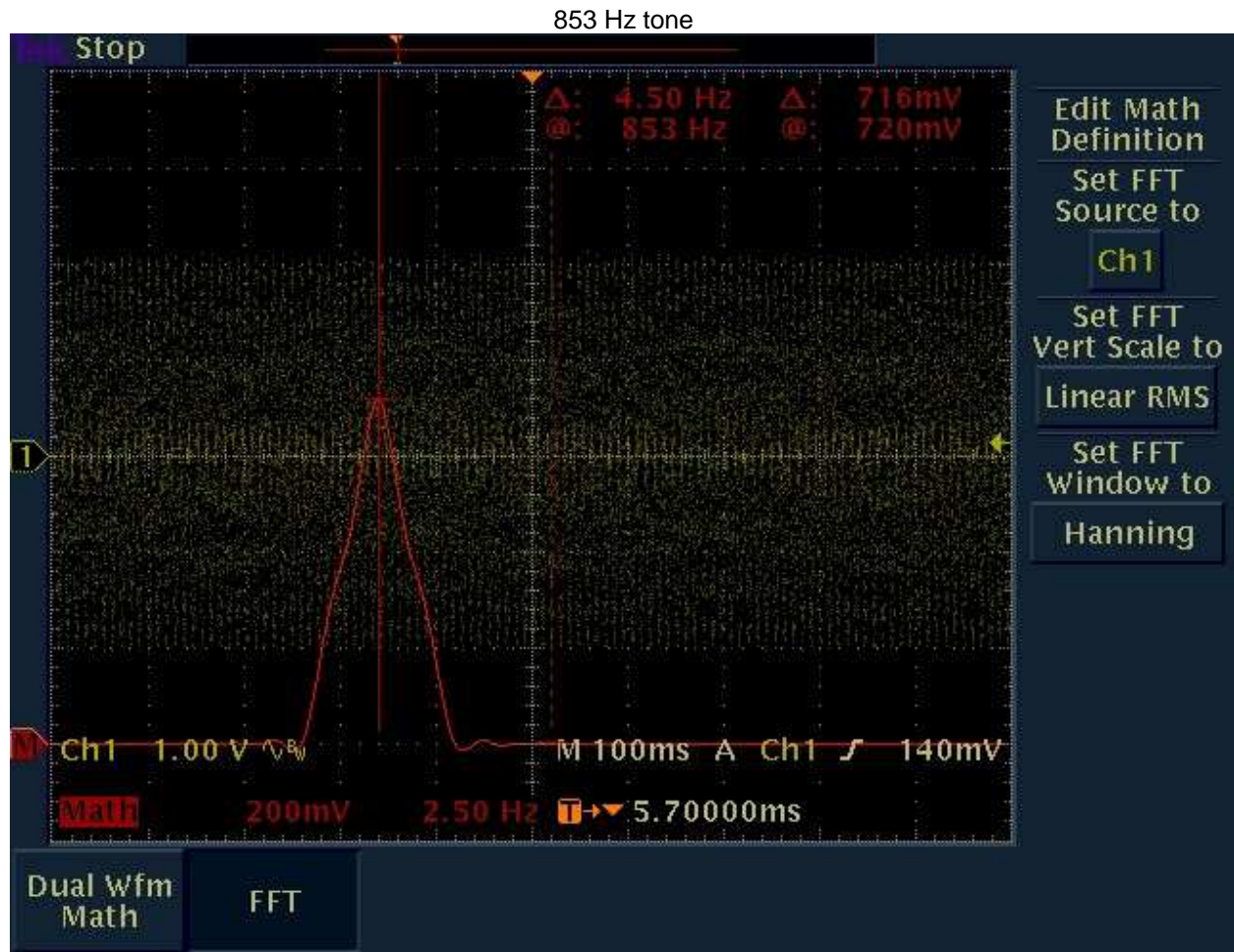

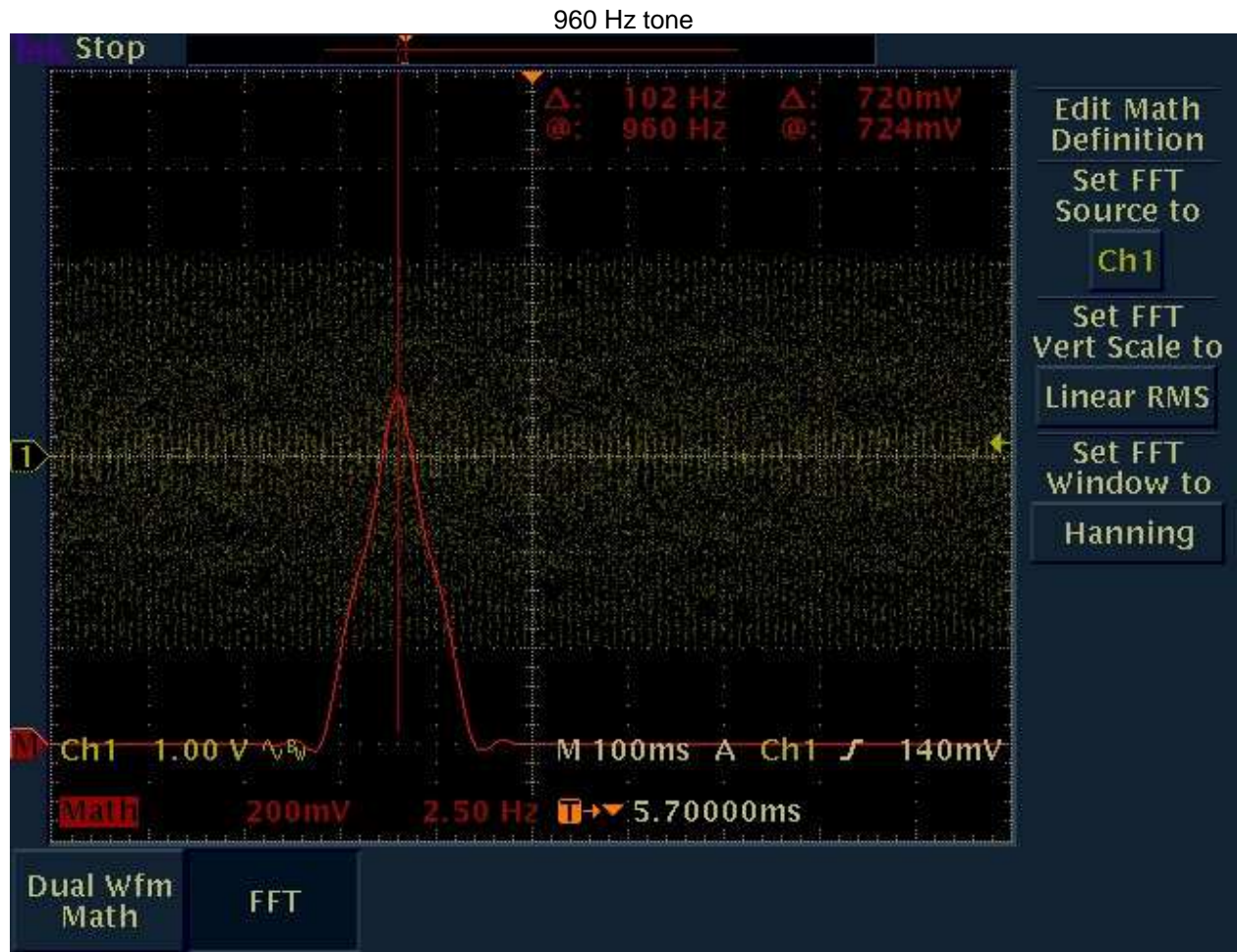

11.31(a)(3): *The message may be audio, video or text.*

The message produced by PAC is audio.

11.31(b): *The ASCII dash and plus symbols are required and may not be used for any other purpose. FM or TV call signs must use a slash ASCII character number 47 (/) in lieu of a dash.*

The dash and plus symbols appear in the EAS message at the appropriate locations and it was verified during that the user is unable to enter a dash into the call sign input. The allowed inputs are A-Z, 0-9, /, (, ), and space. See the 11.31(c) section below for an actual EAS code that was sent.

11.31(c): *The EAS protocol, including any codes, must not be amended, extended or abridged without FCC authorization. The EAS protocol and message format are specified in the following representation.*

*[PREAMBLE]ZCZC-ORG-EEE-PSSCCC+TTTT-JJHHMM-LLLLLLLL-(one second pause)*

*[PREAMBLE]ZCZC-ORG-EEE-PSSCCC+TTTT-JJHHMM-LLLLLLLL-(one second pause)*

*[PREAMBLE]ZCZC-ORG-EEE-PSSCCC+TTTT-JJHHMM-LLLLLLLL-(at least a one second pause)*

*(transmission of 8 to 25 seconds of Attention Signal)*

*(transmission of audio, video or text messages)*

*(at least a one second pause)*

*[PREAMBLE]NNNN (one second pause)*

*[PREAMBLE]NNNN (one second pause)*

*[PREAMBLE]NNNN (at least one second pause)*

It was verified during test that EAS protocol and message format were in compliance with the requirement above and that LLLLLLLL with a "dash" will change to a "slash" before retransmitting.

1<sup>st</sup> Preamble Pause: 1 second

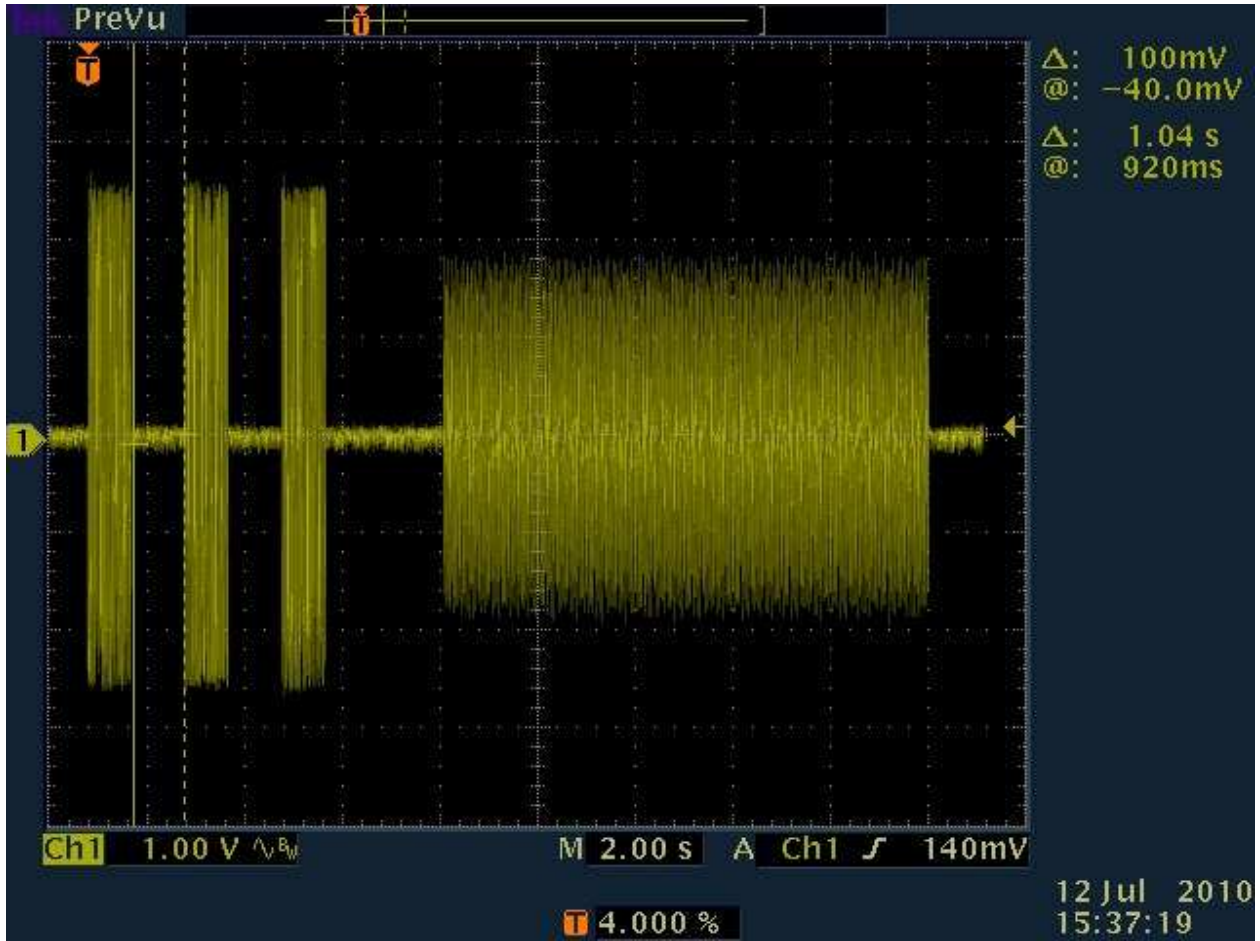



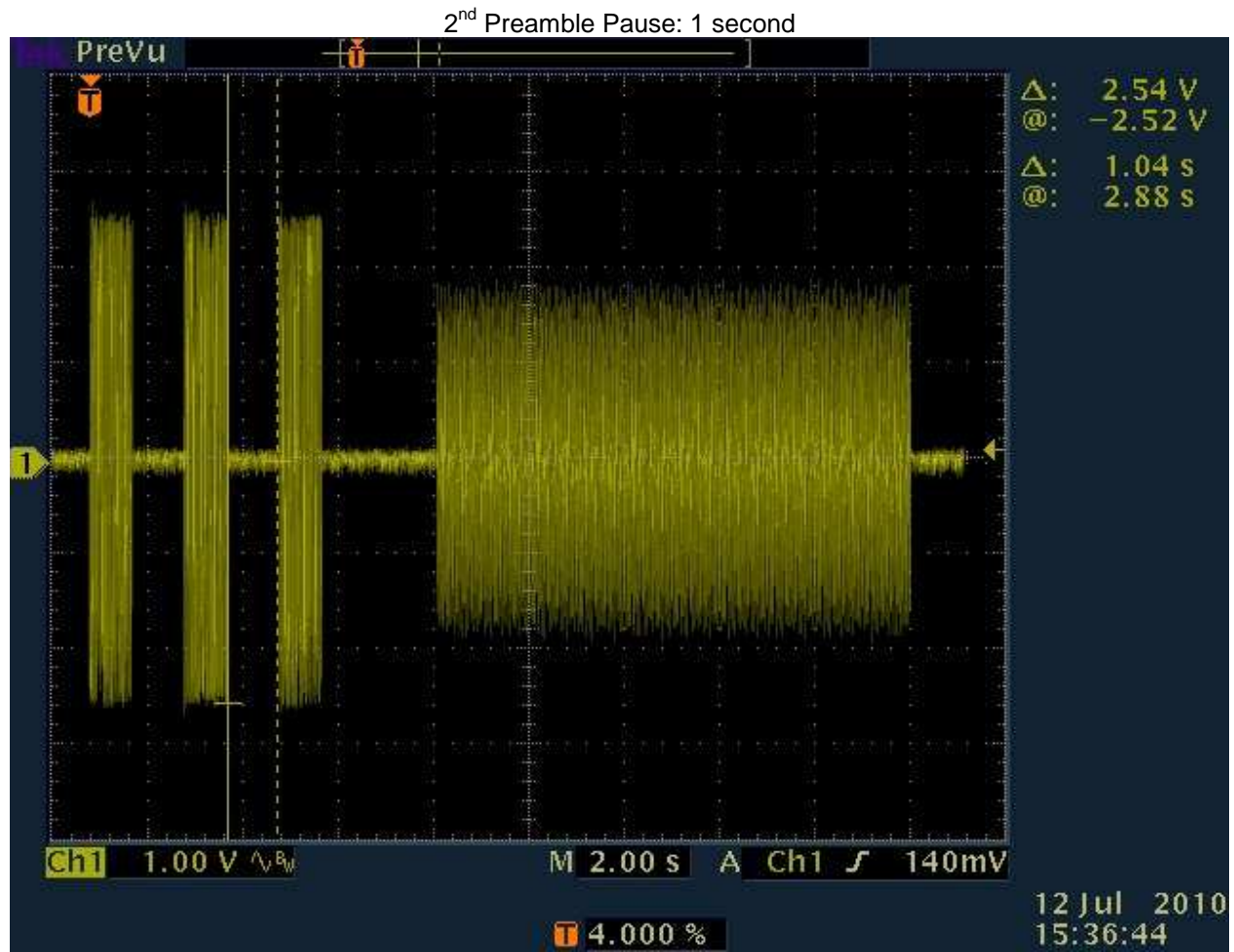

3<sup>rd</sup> Preamble Pause: At least 1 second

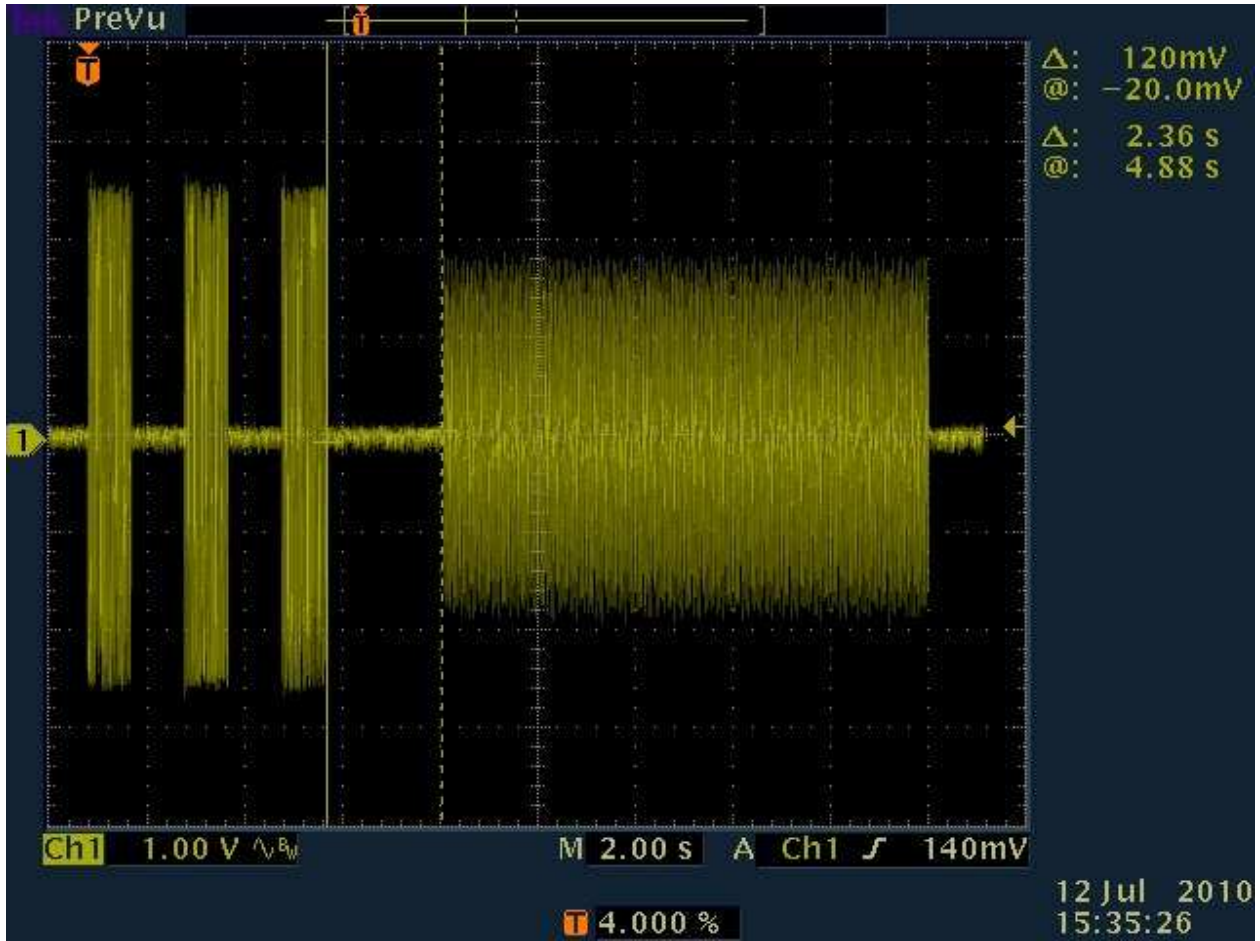

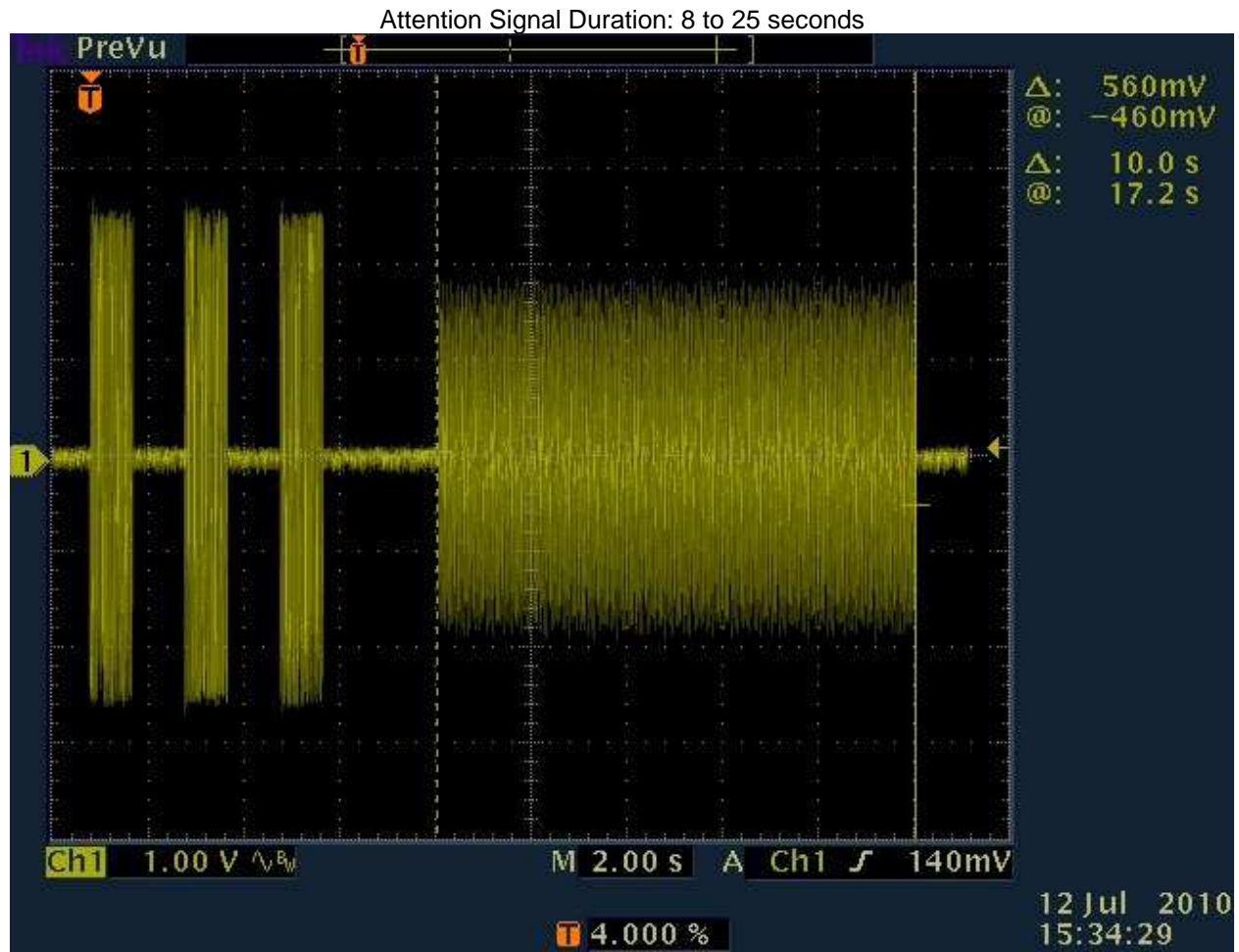

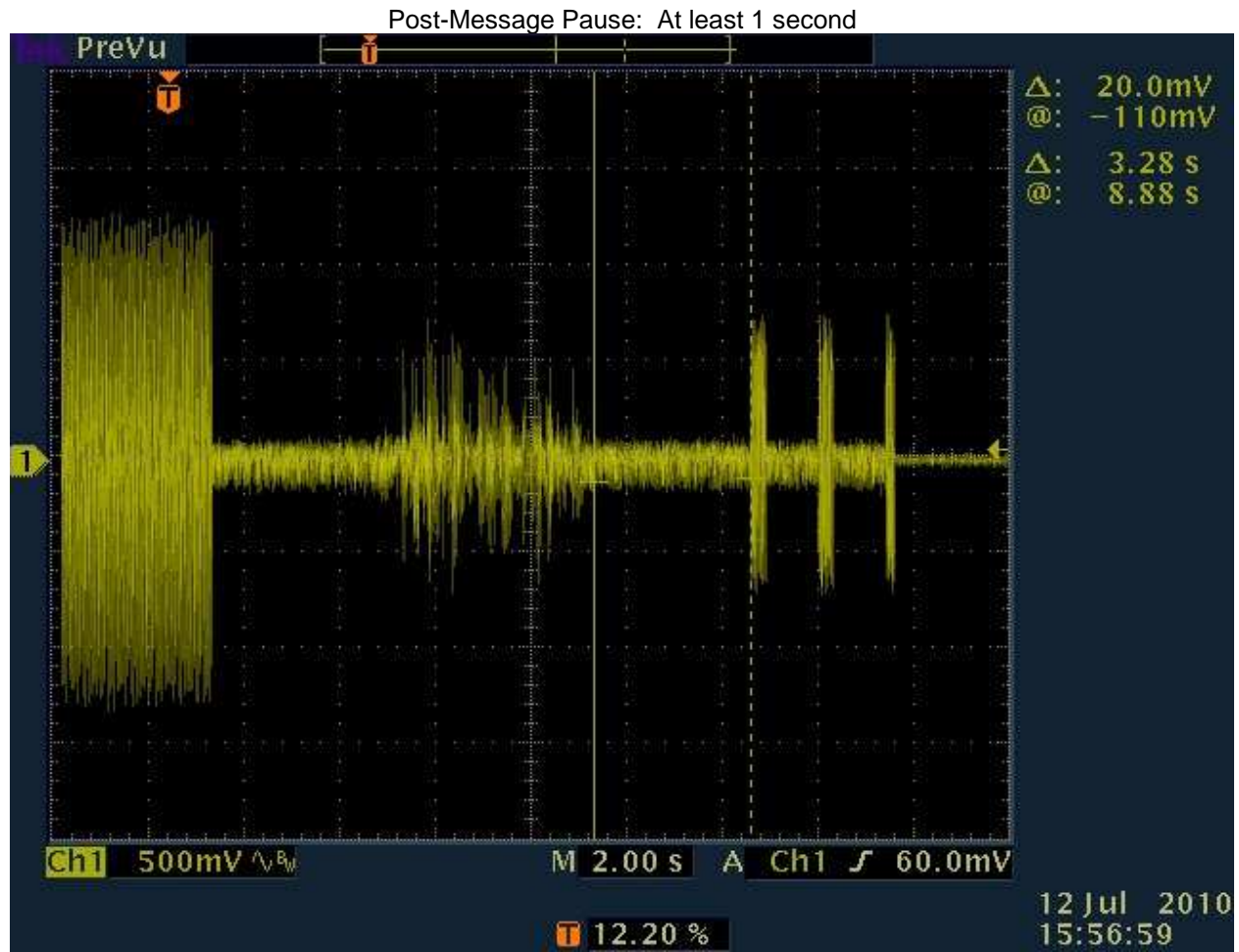

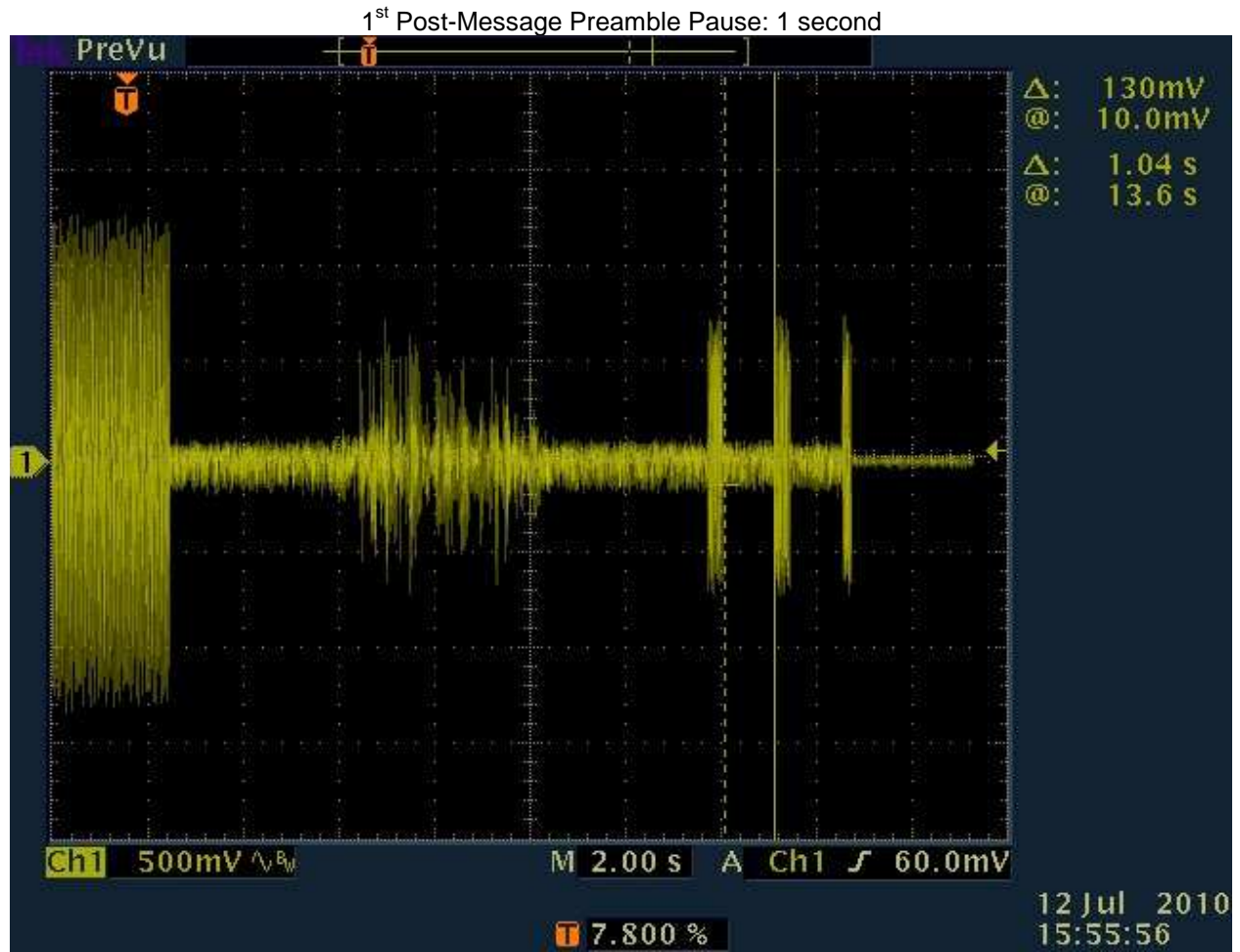

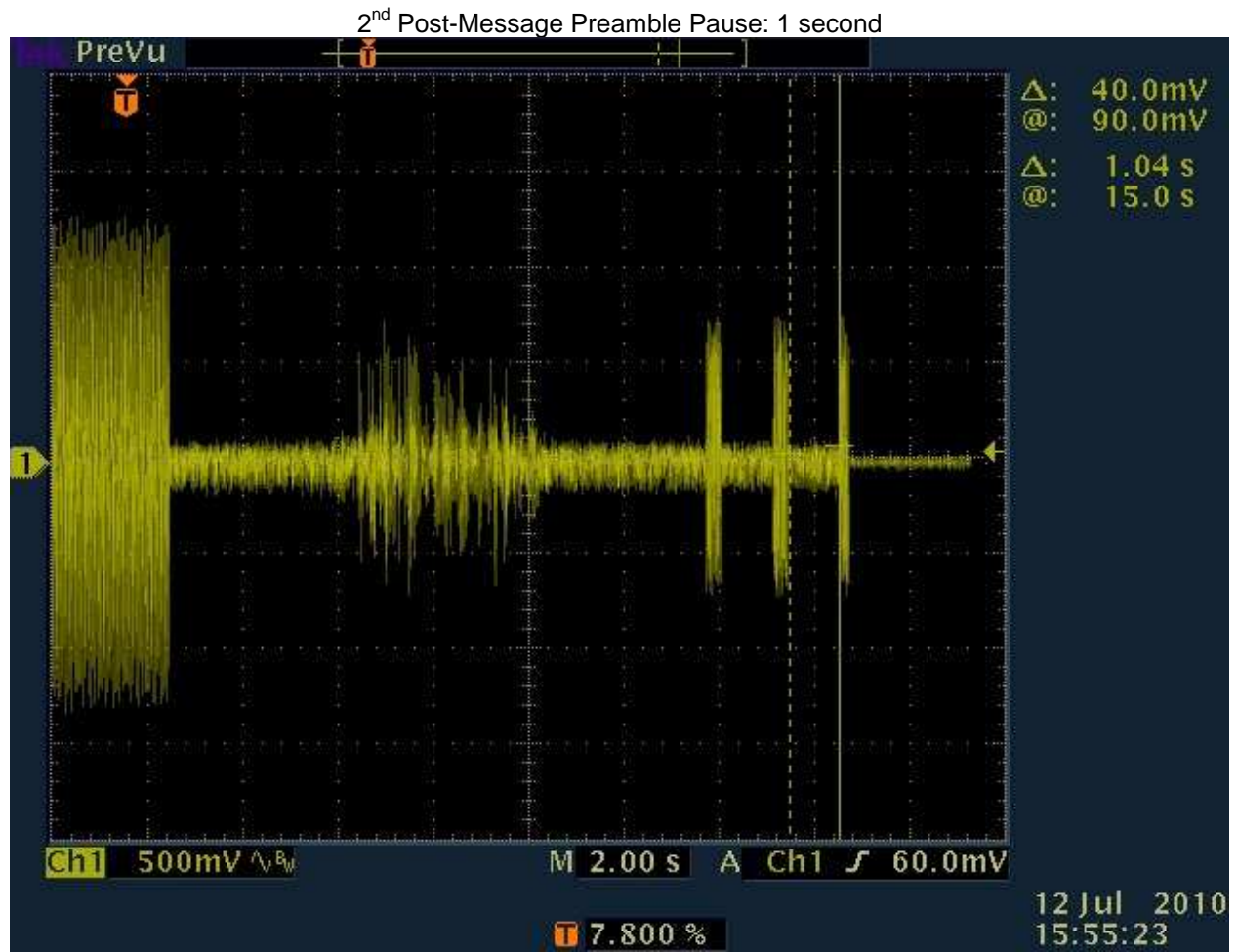

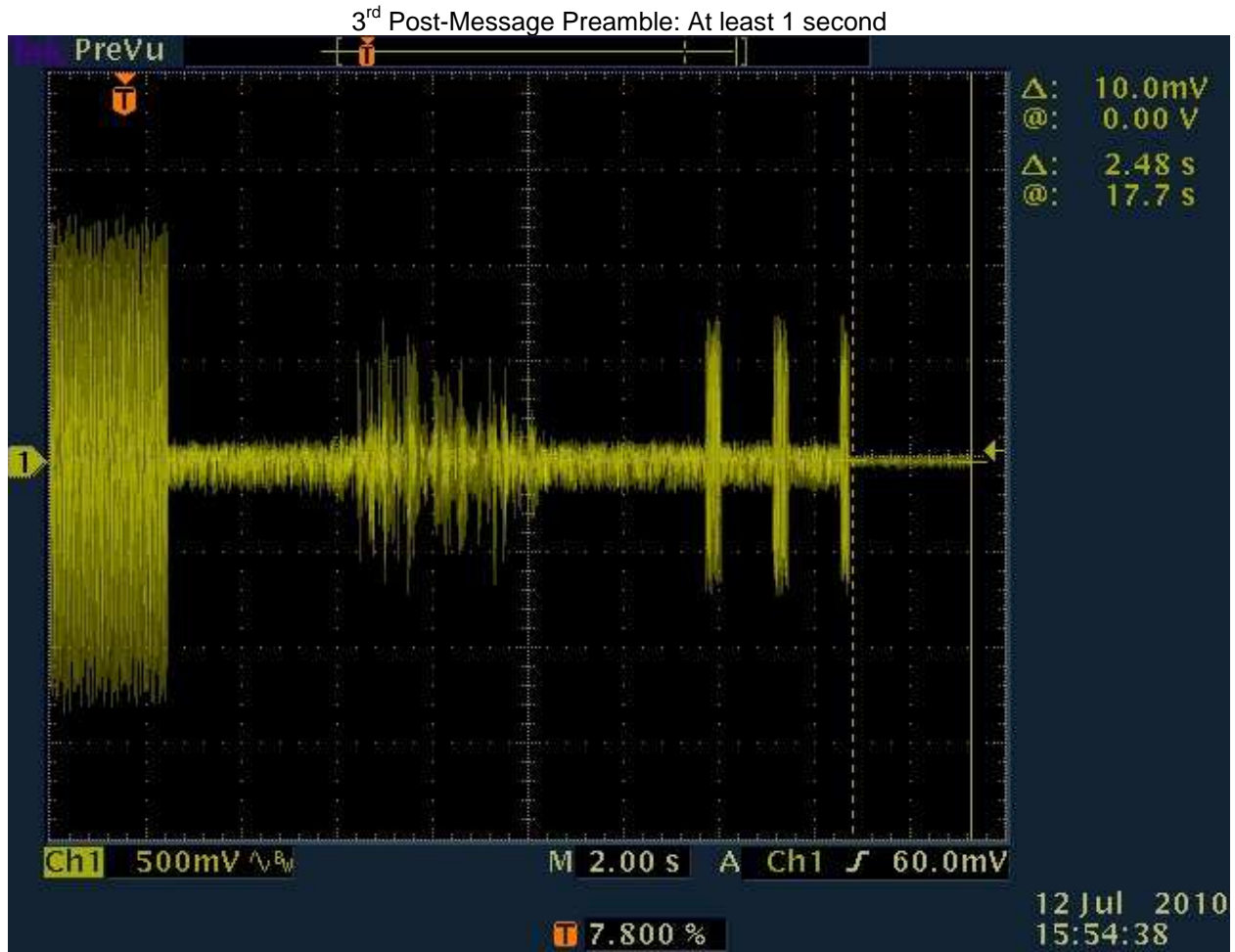

Test Personnel: Kouma Sinn  
Product Standard: FCC Part 11 Subpart B  
Input Voltage: 120V/60Hz

Test Date: 07/12/10, 07/13/10  
Test Levels: N/A  
Ambient Temperature: 21 °C, 21 °C  
Relative Humidity: 66 %, 77%  
Atmospheric Pressure: 1003 mbars, 1006mbar

Deviations, Additions, or Exclusions: None

## 7 EAS Encoder

### 7.1 Method

Tests are performed in accordance with FCC Part 11.32.

**TEST SITE:** EMC Lab

**The EMC Lab** has two Semi-anechoic Chambers and one Shielded Chamber. AC Mains Power is available at 120, 230, and 277 Single Phase; 208, 400, and 480 3-Phase. Large reference ground-planes are installed in the general lab area to facilitate EMC work not requiring a shielded environment.

**The AMAP Building and Lab** includes general lab space that can be used for testing where a shielded/enclosed environment is not required.

### 7.2 Test Equipment Used:

Asset	Description	Manufacturer	Model	Serial	Cal Date	Cal Due
DAV001	Weather Station	Davis Instruments	7400	PE80519A61	06/11/2010	06/11/2011
147027	E Field Generator	Amplifier Research	At3000	25919	VBU	Verified
AMP7	Antenna, Log Periodic, 80 - 1000MHz	Amplifier Research	AT1080	15259	VBU	Verified
AMP45	Isotropic Field Probe	Amplifier Research	FP2000	305608	11/11/2009	11/11/2010
WER 7	Dual Directional Coupler	Werlatone inc.	C5960-13	26116	01/22/2010	01/22/2011
WER3	COUPLER, BI-DIRECTIONAL	Werlatone inc.	C3910	5283	12/02/2009	12/02/2010
HEW63	Generator, Signal	Hewlett Packard	8648C	3847A05291	01/14/2009	01/14/2011
HEW51	METER, POWER	Hewlett Packard	436A/022	2347A17561	10/29/2009	10/29/2010
KAL02	AMPLIFIER; 1kW; 10kHz-200MHz	Kaimus	137C/1-60-105-002	8044-1	VBU	Verified
HEW 64	RF Communications Test Set	Hewlett Packard	8920B	US36141447	05/13/2010	05/13/2011
148012	Temp/Humidity Chamber	Envirotronics	SH27C	08015563S11263	08/27/2009	08/27/2010
ROS001	Spectrum Analyzer 20Hz - 40 GHz	Rohde & Schwartz	FSEK-30	100225	12/04/2009	12/04/2010
TEK4	Oscilloscope, Digital Storage	Tektronix	TDS3052	B014809	10/29/2009	10/29/2010

#### Software Utilized:

Name	Manufacturer	Version
TILE	Quantum Change	3.4.J.2

### 7.3 Results:

The sample tested was found to comply.



7.4 Setup Photographs:

11.32(d): 10 V/m RF field at 1MHz



11.32(d): 0.5V/m RF field at 108MHz



**PAC Front Panel Photograph:**



## 7.5 Data:

11.32(a) EAS Encoders must at a minimum be capable of encoding the EAS protocol described in Sec. 11.31 and providing the EAS code transmission requirements described in Sec. 11.51.

*11.32(a)(1): Encoder programming. Access to encoder programming shall be protected by a lock or other security measures and be configured so that authorized personnel can readily select and program the EAS Encoder with Originator, Event and Location codes for either manual or automatic operation.*

A dialog box asking for an administrator password appears when you try to log into the system control GUI.

*11.32(a)(2) Inputs. The encoder shall have two inputs, one for audio messages and one for data messages (RS-232C with standard protocol and 1200 baud rate).*

The PAC includes two audio inputs, the PC board line in and the microphone input. For data inputs, there are 2 USB ports on the front and 4 USB ports on the back, 1 Ethernet port, and 1 RS-232C serial port with user programmable from 1200 to 9600 Baud. A USB to RS-232C adapter is provided with the system. The USB to RS-232C adapter would be required if the USB ports do not support the RS-232C protocol by themselves.

*11.32(a)(3) Outputs. The encoder shall have two outputs, one audio port and one data port (RS-232C with standard protocol and 1200 baud rate).*

The PAC includes one audio output, the speaker port of the motherboard. For data inputs, there are 2 USB ports on the front and 4 USB ports on the back, 1 Ethernet port, and 1 RS-232C serial port with user programmable from 1200 to 9600 Baud. A USB to RS-232C adapter is provided with the system. The USB to RS-232C adapter would be required if the USB ports do not support the RS-232C protocol by themselves.

*11.32(a)(4) Calibration. EAS Encoders must provide a means to comply with the modulation levels required in Sec. 11.51(f).*

The attention tones and the data tones have independently adjustable signal levels to allow the user to set the modulation level as necessary.

*11.32(a)(5) Day-Hour-Minute and Identification Stamps. The encoder shall affix the JJJHHMM and LLLLLLLL codes automatically to all initial messages.*

The PAC was verified visually during testing that the timestamp and identification codes are affixed to the EAS messages.

*11.32(a)(6) Program Data Retention. Program data and codes shall be retained even with the power removed.*

Programmed data and codes were retained through a power cycle, including complete removal of the power cable.

*11.32(a)(7) Indicator. An aural or visible means that it activated when the Preamble is sent and deactivated at the End of Message code.*

The front panel LED lit during EAS transmission and deactivated upon cessation of transmission (see front panel photo). In addition, the EAS transmission can be viewed on the monitor with Transmit, FSK, Validated, Audio, EOM, tabs. The tab blinked green with an audible sound to indicate the EAS transmission activity. The message was also displayed on the bottom right of the display to indicate incoming message.

11.32(a)(8) Spurious Response. All frequency components outside 200 to 4000 Hz shall be attenuated by 40 dB or more with respect to the output levels of the mark or space frequencies.

The spurious response for the mark and space tones met the 40dBc requirement when operating at maximum drive level.

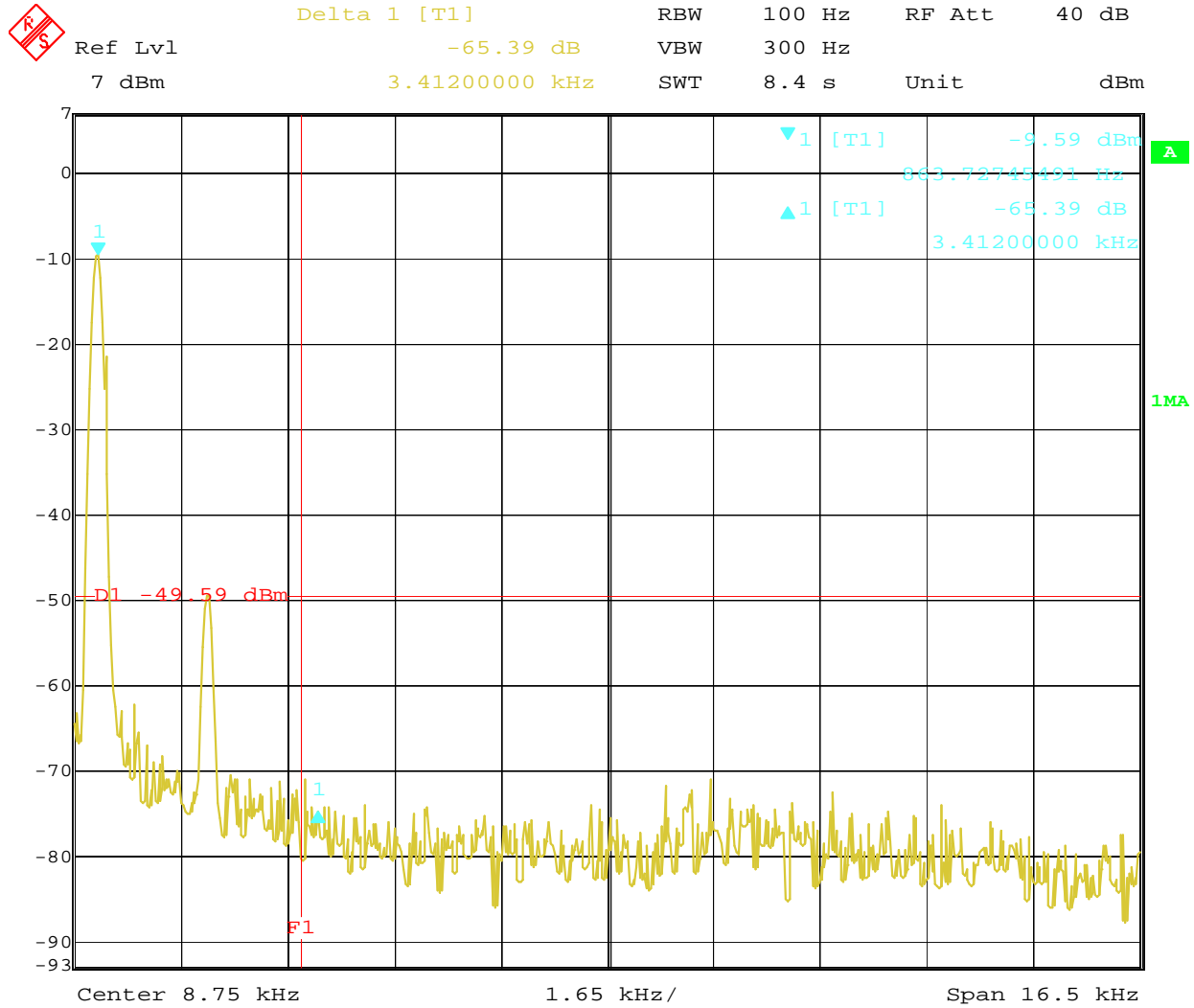

Date: 24.AUG.2010 19:20:17

853 Hz Tone



Delta 1 [T1] RBW 100 Hz RF Att 40 dB  
Ref Lvl -64.76 dB VBW 300 Hz  
7 dBm 3.84000000 kHz SWT 8.4 s Unit dBm

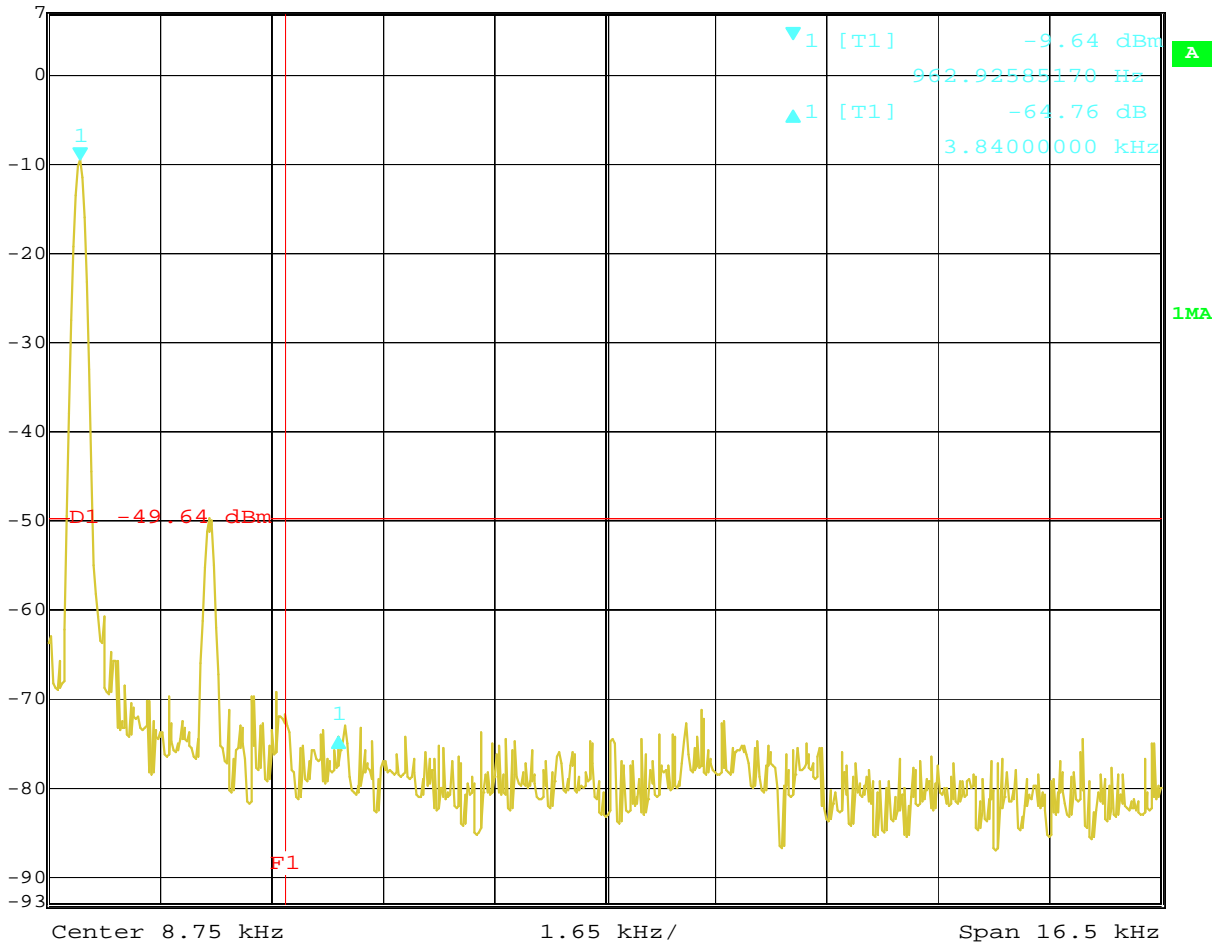

Date: 24.AUG.2010 19:21:25

960 Hz Tone



Delta 1 [T1] RBW 100 Hz RF Att 40 dB  
Ref Lvl -65.55 dB VBW 300 Hz  
7 dBm 4.71906613 kHz SWT 8.4 s Unit dBm

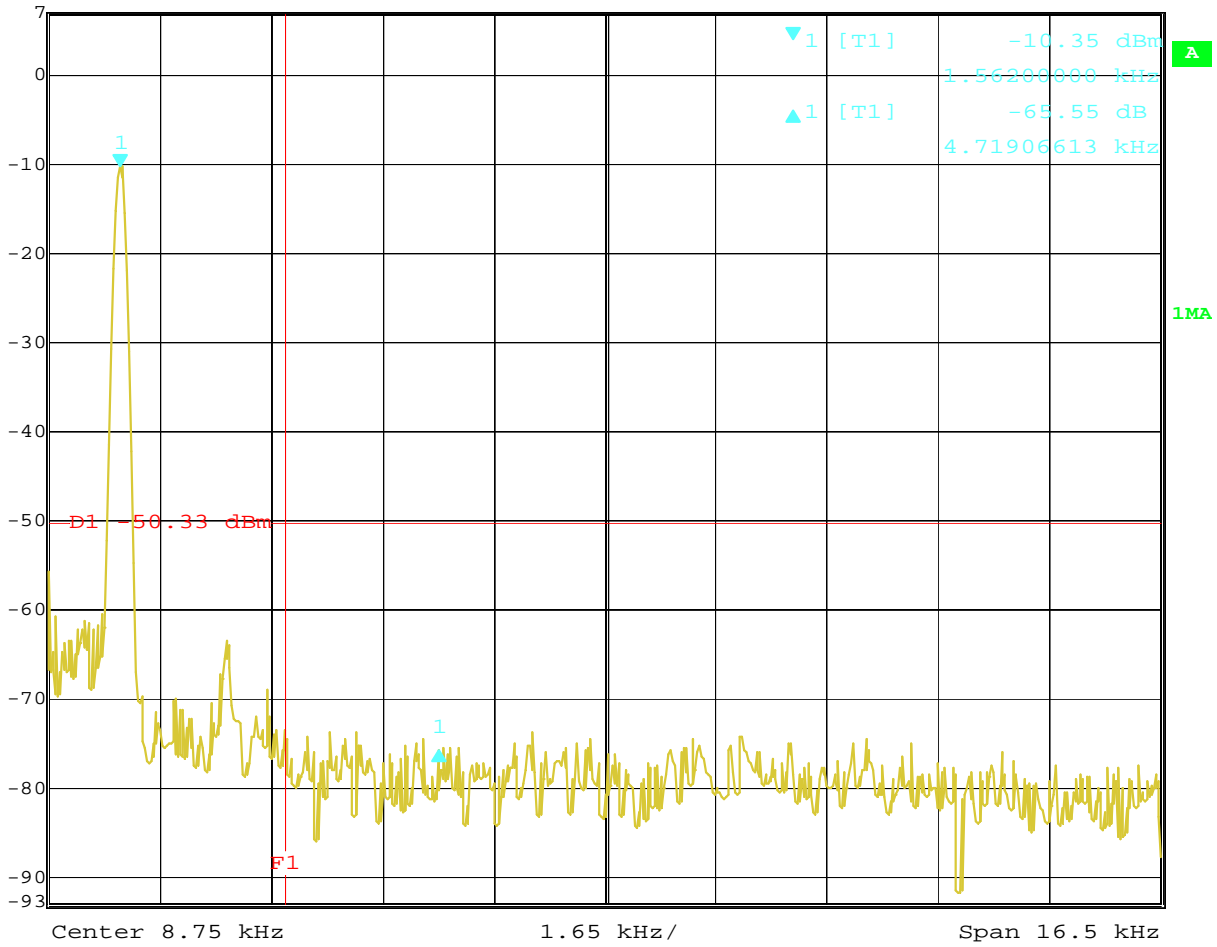

Date: 24.AUG.2010 19:23:38

1562.5 Hz Tone



Delta 1 [T1] RBW 100 Hz RF Att 40 dB  
Ref Lvl -55.20 dB VBW 300 Hz  
7 dBm 2.11589980 kHz SWT 8.4 s Unit dBm

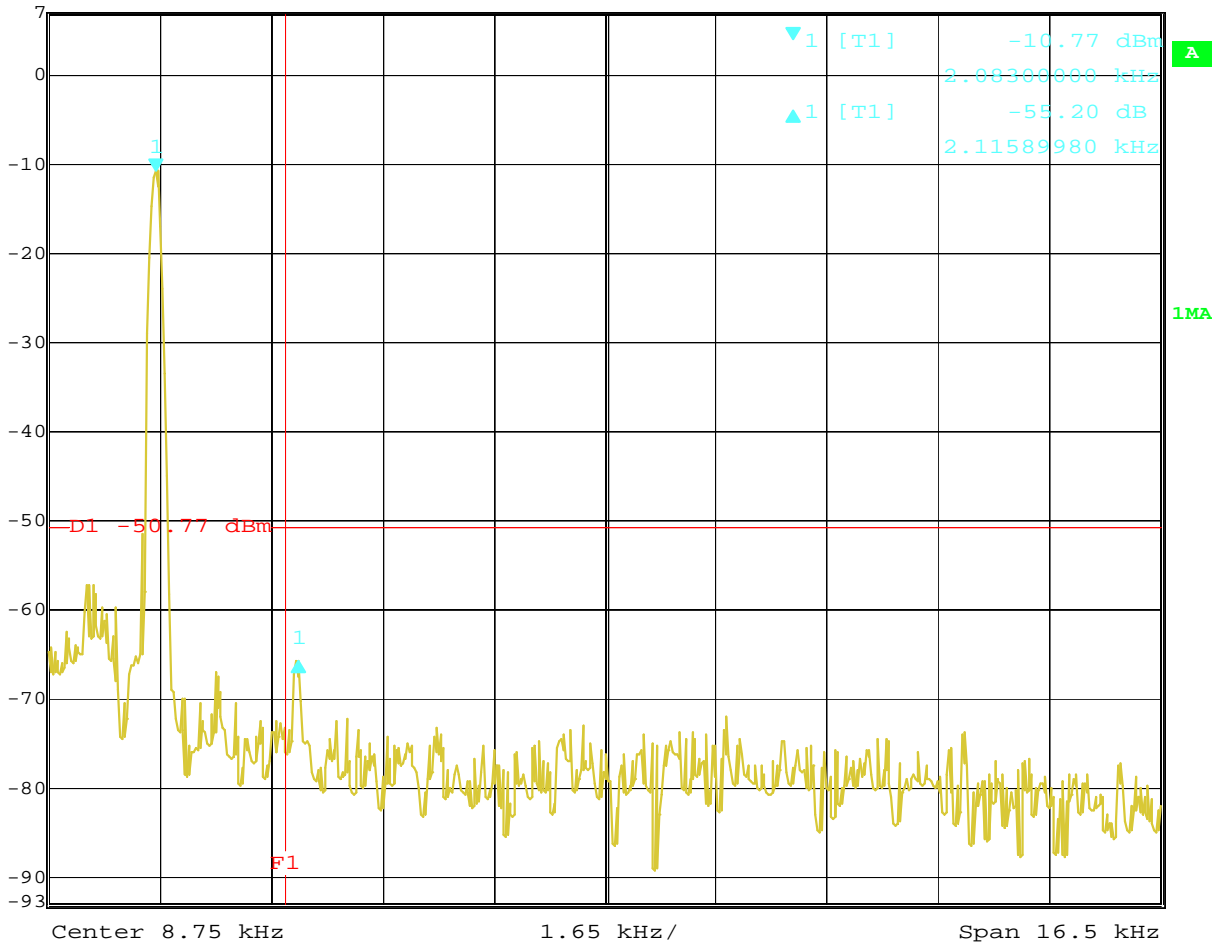

Date: 24.AUG.2010 19:24:27

2083.3 Hz Tone

*11.32(a)(9) Attention Signal generator. The encoder must provide an attention signal that complies with the following: (i) Tone Frequencies. The audio tones shall have fundamental frequencies of 853 and 960 Hz and not vary over 0.5 Hz.*

The line out and ground outputs were connected to the HI audio input of the HP 8920B RF Communications Test Set. The AF analyzer was used to measure the attention tones. A tone was measured at 852.99 Hz and at 959.99 Hz, which are within the required  $\pm 0.5$  Hz.

*11.32(a)(9)(ii) Harmonic Distortion. The total harmonic distortion of each of the audio tones may not exceed 5% at the encoder output terminals.*

Audio Output power from the balanced XLR output was measured at the audio input to the HP 8920B RF Communications Test Set. The LO input was referenced to the HI input with a 600 Ohm impedance. The audio notch filter was set to the tone frequency and distortion was measured using the instrument distortion function.

853 Hz: 1.6%  
960 Hz: 2.3%  
1562.5 Hz: 2.7%  
2083.3 Hz: 2.8%

*11.32(a)(9)(iii) Minimum Level of Output. The encoder shall have an output level capability of at least +8 dBm into a 600 Ohm load impedance at each audio tone. A means shall be provided to permit individual activation of the two tones for calibration of associated systems.*

Audio Output power from the balanced XLR output was measured at the audio input to the HP 8920B RF Communications Test Set. The lo input was referenced to the hi input with a 600 Ohm impedance.

The EUT GUI Tone Amplitude Setting Maxed for the readings below

853 Hz  
8920B Balanced Input: 9.45 dBm

960 Hz  
8920B Balanced Input: 9.40 dBm

1562.5 Hz  
8920B Balanced Input: 8.80 dBm

2083.3 Hz  
8920B Balanced Input: 8.40 dBm



*11.32(a)(9)(iv) Time Period for Transmission of Tones. The encoder shall have timing circuitry that automatically generates the two tones simultaneously for a time period of not less than 8 nor longer than 25 seconds. NOTE: Prior to July 1, 1995, the Attention Signal must be at least 20 and not more than 25 seconds.*

See the EAS Protocol section of the report for a plot of the length of the attention signal, which is 10 seconds.

*11.32(a)(9)(v) Inadvertent activation. The switch used for initiating the automatic generation of the simultaneous tones shall be protected to prevent accidental operation.*

The tone generation command is located in a submenu of the software, so it cannot be inadvertently activated mechanically, and it is password protected to prevent unauthorized use and to prevent accidental selection of the command.

*11.32(a)(9)(vi) Indicator Display. The encoder shall be provided with a visual and/or aural indicator which clearly shows that the Attention Signal is activated.*

The Attention Signal activation can be viewed on the PC monitor and the front panel (see front panel photo)

*11.32(b) Operating Temperature and Humidity. Encoders shall have the ability to operate with the above specifications within an ambient temperature range of 0 to +50 degrees C and a range of relative humidity of up to 95%.*

The PAC was tested at 0 degrees Celsius and 95% humidity, 20 degrees Celsius and 95% humidity, and 50 degrees Celsius and 95% humidity. In all cases, an EAS message was sent by the PAC and was successfully decoded.

*11.32(c) Primary Supply Voltage Variation. Encoders shall be capable of complying with the requirements of this section during a variation in primary supply voltage of 85 percent to 115 percent of its rated value.*

The PAC is rated at 120V/60Hz AC, therefore, it was operated at 102V and 138V AC. At both voltages, an EAS message was sent by the EUT and was successfully decoded.

*11.32(d) Testing Encoder Units. Encoders not covered by Sec. 11.34(e) of this part shall be tested in a 10 V/m minimum RF field at an AM broadcast frequency and a 0.5 V/m minimum RF field at an FM or TV broadcast frequency to simulate actual working conditions.*

The PAC was tested on the front, back, right, and left sides at 108 MHz 0.5 V/m and at 1 MHz 10 V/m, vertical and horizontal polarity. An EAS message was sent by the EUT and was successfully decoded by.

Kouma Sinn, Nicholas

Test Personnel: Abbondante   
 Product Standard: FCC Part 11 Subpart B  
 Input Voltage: 120V/60Hz

Test Date: 07/12/10, 07/13/10, 08/24/2010

Test Levels:	<u>108 MHz 0.5 V/m and at 1 MHz 10 V/m</u>
Ambient Temperature:	<u>21 °C, 21 °C, 21 °C</u>
Relative Humidity:	<u>66 %, 77%, 73%</u>
Atmospheric Pressure:	<u>1003 mbars, 1006mbar, 1008mbars</u>

Deviations, Additions, or Exclusions: None

## 8 EAS Decoder

### 8.1 Method

Tests are performed in accordance with FCC Part 11.33

**TEST SITE:** EMC Lab

**The EMC Lab** has two Semi-anechoic Chambers and one Shielded Chamber. AC Mains Power is available at 120, 230, and 277 Single Phase; 208, 400, and 480 3-Phase. Large reference ground-planes are installed in the general lab area to facilitate EMC work not requiring a shielded environment.

**The AMAP Building and Lab** includes general lab space that can be used for testing where a shielded/enclosed environment is not required.

### 8.2 Test Equipment Used:

Asset	Description	Manufacturer	Model	Serial	Cal Date	Cal Due
DAV001	Weather Station	Davis Instruments	7400	PE80519A61	06/11/2010	06/11/2011
147027	E Field Generator	Amplifier Research	At3000	25919	VBU	Verified
AMP7	Antenna, Log Periodic, 80 - 1000MHz	Amplifier Research	AT1080	15259	VBU	Verified
AMP45	Isotropic Field Probe	Amplifier Research	FP2000	305608	11/11/2009	11/11/2010
WER 7	Dual Directional Coupler	Werlatone inc.	C5960-13	26116	01/22/2010	01/22/2011
WER3	COUPLER, BI-DIRECTIONAL	Werlatone inc.	C3910	5283	12/02/2009	12/02/2010
HEW63	Generator, Signal	Hewlett Packard	8648C	3847A05291	01/14/2009	01/14/2011
HEW51	METER, POWER	Hewlett Packard	436A/022	2347A17561	10/29/2009	10/29/2010
KAL02	AMPLIFIER; 1kW; 10kHz-200MHz	Kaimus	137C/1-60-105-002	8044-1	VBU	Verified
HEW 64	RF Communications Test Set	Hewlett Packard	8920B	US36141447	05/13/2010	05/13/2011
148012	Temp/Humidity Chamber	Envirotronics	SH27C	08015563S11263	08/27/2009	08/27/2010
ROS001	Spectrum Analyzer 20Hz - 40 GHz	Rohde & Schwartz	FSEK-30	100225	12/04/2009	12/04/2010
TEK4	Oscilloscope, Digital Storage	Tektronix	TDS3052	B014809	10/29/2009	10/29/2010

#### Software Utilized:

Name	Manufacturer	Version
TILE	Quantum Change	3.4.J.2

### 8.3 Results:

The sample tested was found to comply.

8.4 Setup Photographs:

11.32(d): 10 V/m RF field at 1MHz

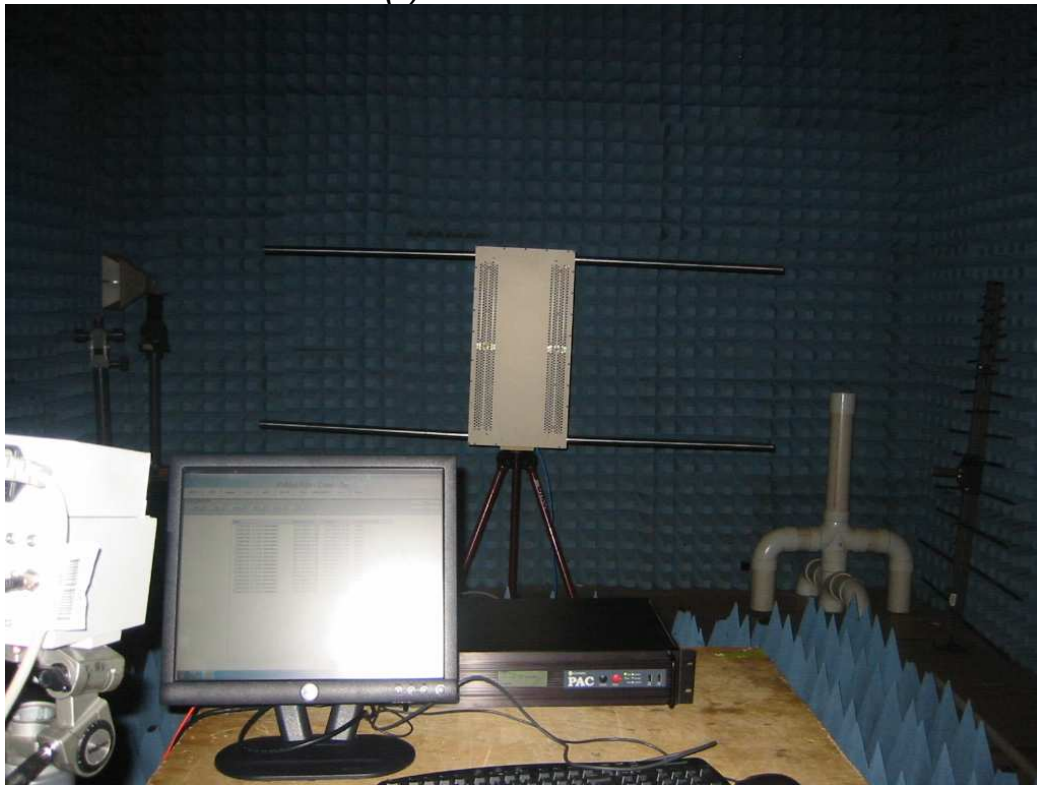

11.32(d): 0.5V/m RF field at 108MHz



Setup Photographs:

PAC Front Panel



## 8.5 Data:

*11.33(a)(1) Inputs. Decoders must have the capability to receive at least 2 audio inputs from EAS monitoring assignments, and one data input (RS-232C with standard protocol and 1200 baud rate). The data input may be used to monitor other communications modes such as Radio Broadcast Data System (RBDS), NWR, satellite, public switched telephone network, or any other source that uses the EAS protocol.*

The PAC provides the required monitoring functions and decodes the EAS protocol by using software that continually records incoming input audio and scans for EAS alert data.

The PAC includes 3 audio inputs and 3 radio inputs which can be configured through software. For data inputs, there are 2 USB ports on the front and 4 USB ports on the back, 1 Ethernet port, and 1 RS-232C serial port with user programmable from 1200 to 9600 Baud. A USB to RS-232C adapter is provided with the system. The USB to RS-232C adapter would be required if the USB ports do not support the RS-232C protocol by themselves.

*11.33(a)(2) Valid codes. There must be a means to determine if valid EAS header codes are received and to determine if preselected header codes are received.*

The PAC uses software that preselect headers for specific actions upon receipt, such as relaying or not relaying an EAS alert based on geographical location and alert type. The tab blinks green to validate EAS header codes.

*11.33(a)(3) Storage. Decoders must provide the means to:*

*11.33(a)(3)(i) Record and store, either internally or externally, at least two minutes of audio or text messages. A decoder manufactured without an internal means to record and store audio or text must be equipped with a means (such as an audio or digital jack connection) to couple to an external recording and storing device.*

The PAC has 232G hard drive. It can store more than two minutes of audio and text messages.

*11.33(a)(3)(ii) Store at least ten preselected event and originator header codes, in addition to the seven mandatory event/originator codes for tests and national activations, and store any preselected location codes for comparison with incoming header codes. A non-preselected header code that is manually transmitted must be stored for comparison with later incoming header codes. The header codes of the last ten received valid messages which still have valid time periods must be stored for comparison with the incoming valid header codes for later messages. These last received header codes will be deleted from storage as their valid time periods expire.*

The PAC storage capability greatly exceeds the limited storage. The received header codes will be deleted from the storage as their valid time periods expire.

*11.33(a)(4) Display and logging. A visual message shall be developed from any valid header codes for tests and national activations and any preselected header codes received. The message shall include the Originator, Event, Location, the valid time period of the message and the local time the message was transmitted. The message shall be in the primary language of the EAS Participant and be fully displayed on the decoder and readable in normal light and darkness. All existing and new models of EAS decoders manufactured after August 1, 2003 must provide a means to permit the selective display and logging of EAS messages containing header codes for state and local EAS events. Effective May 16, 2002, analog radio and television broadcast stations, analog cable systems and wireless cable systems may upgrade their decoders on an optional basis to include a selective display and logging capability for EAS messages containing header codes for state and local events. EAS Participants that install or replace their decoders after February 1, 2004 must install decoders that provide a means to permit the selective display and logging of EAS messages containing header codes for state and local EAS events.*

The Decoder utilizes software for incoming EAS messages on PC monitor. The display message includes the originator, event, location, time period, and local timestamp, and is in English.

*11.33(a)(5) Indicators. EAS decoders must have a distinct and separate aural or visible means to indicate when any of the following conditions occurs:*

*11.33(a)(5)(i) Any valid EAS header codes are received as specified in Sec. 11.33(a)(10).*

The radio tab in the software blinks green.

*11.33(a)(5)(ii) Preprogrammed header codes, such as those selected in accordance with Sec. 11.52(d)(2) are received.*

The FSK tab in the software blinks green

*11.33(a)(5)(iii) A signal is present at each audio input that is specified in Sec. 11.33(a)(1).*

The audio tab in the software blinks green

*11.33(a)(6) Program Data Retention. The program data must be retained even with power removed.*

Programmed data and codes were retained through a power cycle, including complete removal of the power cable.

*11.33(a)(7) Outputs. Decoders shall have the following outputs: a data port or ports (RS-232C with standard protocol and 1200 baud rate) where received valid EAS header codes and received preselected header codes are available; one audio port that is capable of monitoring each decoder audio input; and, an internal speaker to enable personnel to hear audio from each input.*

The Decoder has one RS-232C serial port with user programmable from 1200 to 9600 Baud and one internal and external speaker.

*11.33(a)(8) Decoder Programming. Access to decoder programming shall be protected by a lock or other security measures and be configured so that authorized personnel can readily select and program the EAS Decoder with preselected Originator, Event and Location codes for either manual or automatic operation.*

The programming and all commands are password protected to prevent unauthorized or inadvertent use.

*11.33(a)(9) Reset. There shall be a method to automatically or manually reset the decoder to the normal monitoring condition. Operators shall be able to select a time interval, not less than two minutes, in which the decoder would automatically reset if it received an EAS header code but not an end-of-message (EOM) code. Messages received with the EAN Event codes shall disable the reset function so that lengthy audio messages can be handled. The last message received with valid header codes shall be displayed as required by paragraph (a)(4) of this section before the decoder is reset.*

The Decoder automatically timed out on an EAS message that was longer than 2 minutes if it received an EAS header code but not an EOM code. The Decoder did not time out when an EAN was sent and the audio was allowed to extend for longer than two minutes. All valid EAS messages are automatically displayed upon receipt of the valid header codes, which occurs before the audio portion of the message is received. Therefore, all valid EAS messages will be displayed on the PC monitor before the decoder is reset.

*11.33(a)(10) Message Validity. An EAS Decoder must provide error detection and validation of the header codes of each message to ascertain if the message is valid. Header code comparisons may be accomplished through the use of a bit-by-bit compare or any other error detection and validation protocol. A header code must only be considered valid when two of the three headers match exactly. Duplicate messages must not be relayed automatically.*

The main screen on the PC monitor lights up for message validity.

*11.33(a)(11) A header code with the EAN Event code specified in Sec. 11.31(c) that is received through any of the audio inputs must override all other messages.*

The EAN Event code was simulated during testing and verified that the decoder did initiate an override and immediately relayed the EAN with no time out.

*11.33(b) Attention Signal – Not applicable, the decoder for was not designed for demuting.*

*11.33(c) Decoders shall be capable of operation within the tolerances specified in this section as well as those in Sec. 11.32 (b), (c) and (d).*

*11.32(b) Operating Temperature and Humidity. Encoders shall have the ability to operate with the above specifications within an ambient temperature range of 0 to +50 degrees C and a range of relative humidity of up to 95%.*

The Decoder was tested at 0 degrees Celsius and 95% humidity, 20 degrees Celsius and 95% humidity, and 50 degrees Celsius and 95% humidity. In all cases, an EAS message was sent by the support encoder and was successfully decoded.

*11.32(c) Primary Supply Voltage Variation. Encoders shall be capable of complying with the requirements of this section during a variation in primary supply voltage of 85 percent to 115 percent of its rated value.*

The Decoder is rated at 120V/60Hz AC, therefore it was operated at 102V and 138V AC. At both voltages, an EAS message was sent by the support encoder and was successfully decoded.

*11.32(d) Testing Encoder Units. Encoders not covered by Sec. 11.34(e) of this part shall be tested in a 10 V/m minimum RF field at an AM broadcast frequency and a 0.5 V/m minimum RF field at an FM or TV broadcast frequency to simulate actual working conditions.*

The Decoder was tested on the front, back, right and left sides at 1 MHz 10V/m and at 108 MHz 0.5V/m, vertical and horizontal polarity. An EAS message was sent by the support encoder and was successfully decoded.

Test Personnel:	<u>Kouma Sinn</u>
Product Standard:	<u>FCC Part 11 Subpart B</u>
Input Voltage:	<u>120V/60Hz</u>

Test Date:	<u>07/12/10, 07/13/10</u>
Test Levels:	<u>N/A</u>
Ambient Temperature:	<u>21 °C, 21 °C</u>
Relative Humidity:	<u>66 %, 77%</u>
Atmospheric Pressure:	<u>1003 mbars, 1006mbar</u>

Deviations, Additions, or Exclusions: None



**9 Revision History**

<b>Revision Level</b>	<b>Date</b>	<b>Report Number</b>	<b>Notes</b>
0	08/25/2010	100137947BOX-006	Original Issue