



FCC PART 22 AND PART 90 TEST REPORT

For

SHENZHEN COVALUE COMMUNICATIONS CO.,LTD.

2/F., Bldg. 24, XiLi Industrial Park, No.119 Xinguang Rd, Xili, Nanshan, Shenzhen, China

FCC ID: Y4GDR7800-2

Report Type: Original Report	Product Name: FM TRANSCEIVER
Test Engineer: <u>Lorin Bian</u>	<i>Lorin Bian</i>
Report Number: <u>RDG161026001</u>	
Report Date: <u>2016-12-05</u>	
Reviewed By: <u>Henry Ding</u> EMC Leader	<i>Henry Ding</i>
Test Laboratory:	Bay Area Compliance Laboratories Corp. (Chengdu) 5040, HuiLongWan Plaza, No. 1, ShaWan Road, JinNiu District, ChengDu, China Tel: 028-65523123, Fax: 028-65525125 www.baclcorp.com

Note: This test report was prepared for the customer shown above and for the device described herein. It may not be duplicated or used in part without prior written consent from Bay Area Compliance Laboratories Corp. (Chengdu). Any unauthorized alteration, forgery or falsification of the content or appearance of this document is unlawful and offenders may be prosecuted to the fullest extent of the law. This report was valid only with a valid digital signature.

TABLE OF CONTENTS

GENERAL INFORMATION	4
PRODUCT DESCRIPTION FOR EQUIPMENT UNDER TEST (EUT).....	4
OBJECTIVE.....	4
RELATED SUBMITTAL(S)/GRANT(S).....	4
TEST METHODOLOGY.....	5
TEST FACILITY.....	5
SYSTEM TEST CONFIGURATION	6
DESCRIPTION OF TEST CONFIGURATION.....	6
SUPPORT EQUIPMENT LIST AND DETAILS.....	6
BLOCK DIAGRAM OF TEST SETUP.....	6
SUMMARY OF TEST RESULTS.....	8
FCC §1.1310 & §2.1093 - RF EXPOSURE.....	9
APPLICABLE STANDARD.....	9
TEST RESULT.....	9
FCC §2.1046 & § 22.727&§90.205- RF OUTPUT POWER.....	10
APPLICABLE STANDARD.....	10
TEST PROCEDURE.....	10
TEST EQUIPMENT LIST AND DETAILS.....	10
TEST DATA.....	10
FCC §2.1047 & §90.207 - MODULATION CHARACTERISTIC	12
APPLICABLE STANDARD.....	12
TEST PROCEDURE.....	12
TEST EQUIPMENT LIST AND DETAILS.....	12
TEST DATA.....	12
FCC §2.1049& §22.357 & § 22.731 &§90.209 & §90.210 – OCCUPIED BANDWIDTH & EMISSION MASK	16
APPLICABLE STANDARD.....	16
TEST EQUIPMENT LIST AND DETAILS.....	17
TEST PROCEDURE.....	17
TEST DATA.....	17
FCC §2.1051& §22.861 & §90.210 - SPURIOUS EMISSIONS AT ANTENNA TERMINALS.....	25
APPLICABLE STANDARD.....	25
TEST EQUIPMENT LIST AND DETAILS.....	25
TEST PROCEDURE.....	26
TEST DATA.....	26
FCC §2.1053 & §22.861 & §90.210 - RADIATED SPURIOUS EMISSIONS.....	31
APPLICABLE STANDARD.....	31
TEST EQUIPMENT LIST AND DETAILS.....	31
TEST PROCEDURE.....	32
TEST DATA.....	32
FCC §2.1055 & § 22.355 & §90.213- FREQUENCY STABILITY	35
APPLICABLE STANDARD.....	35
TEST EQUIPMENT LIST AND DETAILS.....	35
TEST PROCEDURE.....	35

TEST DATA 36

FCC §90.214 - TRANSIENT FREQUENCY BEHAVIOR 38

APPLICABLE STANDARD 38

TEST EQUIPMENT LIST AND DETAILS 38

TEST PROCEDURE 38

TEST DATA 39

GENERAL INFORMATION

Product Description for Equipment under Test (EUT)

The **SHENZHEN COVALUE COMMUNICATIONS CO.,LTD.** 's product, model: **DR7800-2, DR7500-2 (FCC ID: Y4GDR7800-2)** (the "EUT") in this report are **FM TRANSCEIVER**, which were measured approximately:6.8 cm (H) x 5.1 cm (W) x 15.3 cm (H), rated input voltage: DC7.4V Li-ion battery or DC12V from adapter.

Adapter Information:

MODEL: YS02-120100U

INPUT: AC 100-240V, 50/60Hz, 0.32A MAX

OUTPUT: DC 12V, 1000mA

Note: The series product, model DR7800-2, DR7500-2, DR7810-2, DR7820-2, DR7600-2, DR7610-2, DR7620-2, DR7510-2, DR7520-2 are electrically identical, we selected DR7800-2 for fully testing, the difference between them is explained in the declaration letter.

**All measurement and test data in this report was gathered from final production sample, serial number: 161026001 (assigned by the BACL, Chengdu). It may have deviation from any other sample. The EUT supplied by the applicant was received on 2016-10-26, and EUT conformed to test requirement.*

Objective

This test report is prepared on behalf of **SHENZHEN COVALUE COMMUNICATIONS CO.,LTD.** in accordance with Part 2, Part 22 and Part 90 of the Federal Communications Commission rules.

Related Submittal(s)/Grant(s)

No related submittal(s).

Test Methodology

All tests and measurements indicated in this document were performed in accordance with the Code of federal Regulations Title 47 Part 2, Sub-part J as well as the following individual parts:

Part 90 – PRIVATE LAND MOBILE RADIO SERVICES

Applicable Standards: TIA-603-D.

The uncertainty of any RF tests which use conducted method measurement is ± 3.17 dB, the uncertainty of any radiation on emissions measurement is:

30M~200MHz: ± 4.7 dB;
200M~1GHz: ± 6.0 dB;
1G-6GHz: ± 5.13 dB;
6G~25GHz: ± 5.47 dB;

And the uncertainty will not be taken into consideration for all test data recorded in the report.

Test Facility

The test site used by BACL to collect test data is located in the 5040, HuiLongWan Plaza, No. 1, ShaWan Road, JinNiu District, ChengDu, China

Test site at BACL has been fully described in reports submitted to the Federal Communication Commission (FCC). The details of these reports have been found to be in compliance with the requirements of Section 2.948 of the FCC Rules on April 24, 2015. The facility also complies with the radiated and AC line conducted test site criteria set forth in ANSI C63.4-2014.

The Federal Communications Commission has the reports on file and is listed under FCC Registration No.: 560332. The test site has been approved by the FCC for public use and is listed in the FCC Public Access Link (PAL) database.

SYSTEM TEST CONFIGURATION

Description of Test Configuration

The system was configured for testing in a test mode.

EUT Specification:

Operating Frequency Band	400-512MHz
Modulation Mode	FM/4FSK
Channel Spacing	12.5 kHz
Rated Output Power	High: 4W Low: 1W

Support Equipment List and Details

Manufacturer	Description	Model	Serial Number
N/A	Terminal Load (50 Ω)	N/A	N/A
HP	RF Communications Test Set	8920A	00 247
N/A	Splitter	N/A	N/A

Block Diagram of Test Setup

Conducted:

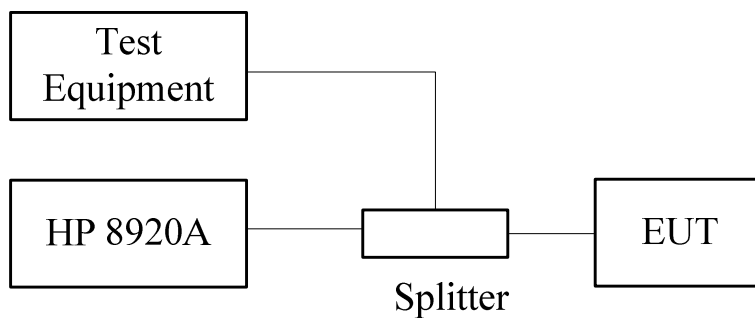

Radiated:

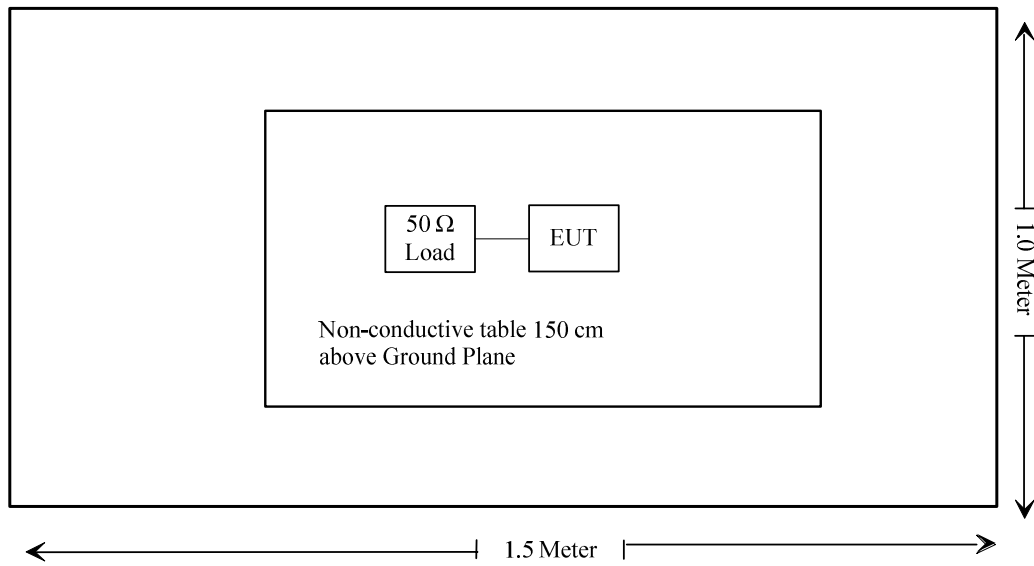

SUMMARY OF TEST RESULTS

FCC Rules	Description of Test	Results
§1.1310 and §2.1093	RF Exposure	Compliant
§2.1046; § 22.727;§90.205	RF Output Power	Compliant
§2.1047;§90.207	Modulation Characteristic	Compliant
§2.1049;§22.357;§ 2 2.731;§90.209; §90.210	Occupied Bandwidth & Emission Mask	Compliant
§2.1051; §22.861;§90.210	Spurious Emission at Antenna Terminal	Compliant
§2.1053; §22.861;§90.210	Spurious Radiated Emissions	Compliant
§2.1055; § 22.355;§90.213	Frequency Stability	Compliant
§90.214	Transient Frequency Behavior	Compliant

FCC §1.1310 & §2.1093 - RF EXPOSURE

Applicable Standard

FCC§1.1310 and §2.1093.

Test Result

Compliant, please refer to the SAR report: RDG161026001-20A.

FCC §2.1046 & § 22.727 & §90.205- RF OUTPUT POWER

Applicable Standard

FCC §2.1046, § 22.727 and §90.205.

Test Procedure

Conducted RF Output Power:

TIA-603-D section 2.2.1

The RF output of the transmitter was connected to the input of the spectrum analyzer through sufficient attenuation.

Spectrum Analyzer setting:

RBW	VBW
100 kHz	300 kHz

Test Equipment List and Details

Manufacturer	Description	Model No.	Serial No.	Calibration Date	Calibration Due Date
Rohde & Schwarz	Signal Analyzer	FSIQ26	831929/005	2016-09-21	2017-09-20
N/A	RF Attenuator	20dB	N/A	Each Time	/

* **Statement of Traceability:** BAAC (Chengdu) attested that all calibrations have been performed, traceable to National Primary Standards and International System of Units (SI).

Test Data

Environmental Conditions

Temperature:	26.7 °C
Relative Humidity:	36%
ATM Pressure:	101.5kPa

The testing was performed by Lorin Bian on 2016-12-02.

Test Result: Compliant. Please refer to following tables.

FCC Part 90:

Modulation	Channel Spacing (kHz)	f _c (MHz)	Conducted Output Power (W)		Note
			High	Low	
FM	12.5	400.0125	4.14	1.05	Not for FCC Review
		453.2125	4.13	1.10	/
		511.9875	4.11	1.09	/
4FSK		400.0125	4.14	1.03	Not for FCC Review
		453.2125	4.10	1.10	/
		511.9875	4.12	1.10	/

FCC Part 22:

Modulation	Channel Spacing (kHz)	f _c (MHz)	Conducted Output Power (W)		Note
			High	Low	
FM	12.5	454.0125	4.15	1.01	/
4FSK		454.0125	4.18	1.09	/

Note: The rated high power is 4W (36 dBm) and low power is 1W (30 dBm).

FCC §2.1047 & §90.207 - MODULATION CHARACTERISTIC

Applicable Standard

FCC§2.1047 & §90.207:

- (a) Equipment which utilizes voice modulated communication shall show the frequency response of the audio modulating circuit over a range of 100 to 5000 Hz. for equipment which is required to have a low pass filter, the frequency response of the filter, or all of the circuitry installed between the modulation limited and the modulated stage shall be supplied.
- (b) Equipment which employs modulation limiting, a curve showing the percentage of modulation versus the modulation input voltage shall be supplied.

Test Procedure

Test Method: TIA/EIA-603 2.2.3

Test Equipment List and Details

Manufacturer	Description	Model No.	Serial No.	Calibration Date	Calibration Due Date
HP	RF Communications Test Set	8920A	00 247	2016-08-10	2017-08-10
N/A	RF Attenuator	20dB	N/A	Each Time	/

* **Statement of Traceability:** BA CL (Chengdu) attested that all calibrations have been performed, traceable to National Primary Standards and International System of Units (SI).

Test Data

Environmental Conditions

Temperature:	26.7 °C
Relative Humidity:	36%
ATM Pressure:	101.5 kPa

The testing was performed by Lorin Bian on 2016-12-02.

Test Result: Compliant. Please refer to following table and plots.

MODULATION LIMITING

Carrier Frequency: 453.2125 MHz, Channel Spacing = 12.5 kHz

Audio Frequency (Hz)	Instantaneous		Steady-state		Limit [kHz]
	Deviation (@+20dB) [kHz]	Deviation (@-20dB) [kHz]	Deviation (@+20dB) [kHz]	Deviation (@-20dB) [kHz]	
300	0.979	0.104	0.96	0.098	2.5
400	1.205	0.111	1.18	0.098	2.5
500	1.573	0.136	1.563	0.101	2.5
600	1.744	0.147	1.707	0.132	2.5
700	1.768	0.153	1.745	0.121	2.5
800	1.852	0.168	1.813	0.148	2.5
900	1.939	0.167	1.931	0.151	2.5
1000	2.103	0.19	2.094	0.171	2.5
1200	2.103	0.222	2.087	0.195	2.5
1400	2.035	0.229	2.028	0.214	2.5
1600	1.971	0.256	1.943	0.228	2.5
1800	1.936	0.264	1.918	0.252	2.5
2000	1.899	0.289	1.875	0.262	2.5
2200	1.818	0.295	1.784	0.273	2.5
2400	1.996	0.326	1.977	0.297	2.5
2600	2.002	0.336	1.971	0.325	2.5
2800	1.989	0.349	1.969	0.34	2.5
3000	1.709	0.341	1.699	0.33	2.5

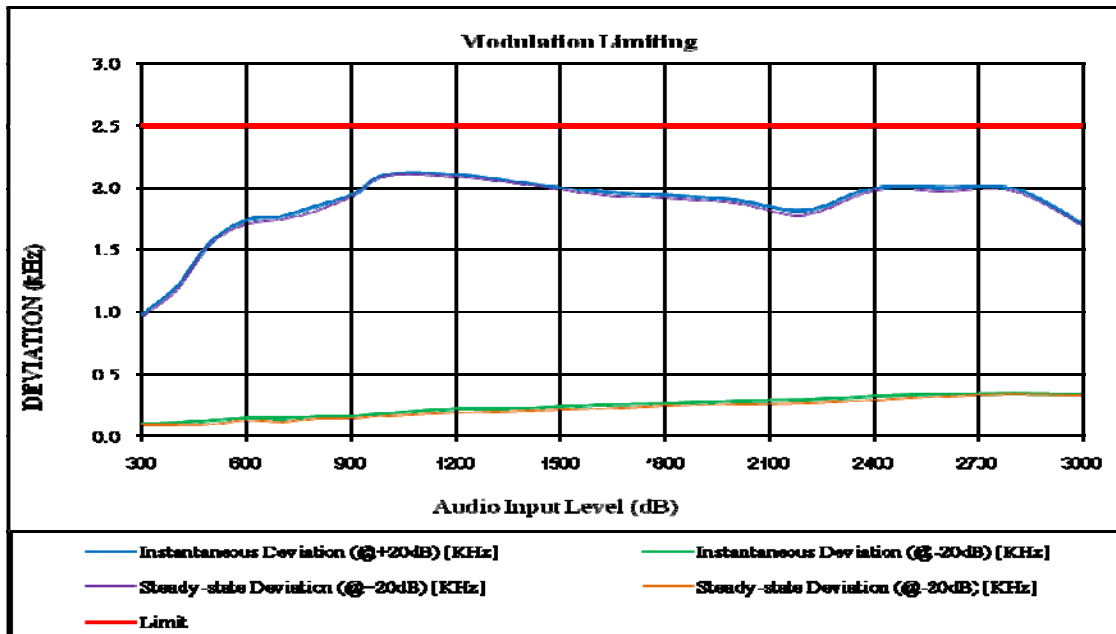

Audio Frequency Response

Carrier Frequency: 453.2125 MHz, Channel Spacing = 12.5 kHz

Audio Frequency	Response Attenuation
Hz	dB
300	-12.08
400	-8.58
500	-6.06
600	-4.22
700	-2.82
800	-1.71
900	-0.65
1000	0.00
1200	1.61
1400	2.87
1600	4.06
1800	5.08
2000	5.89
2200	6.37
2400	6.48
2600	6.75
2800	6.97
3000	7.01

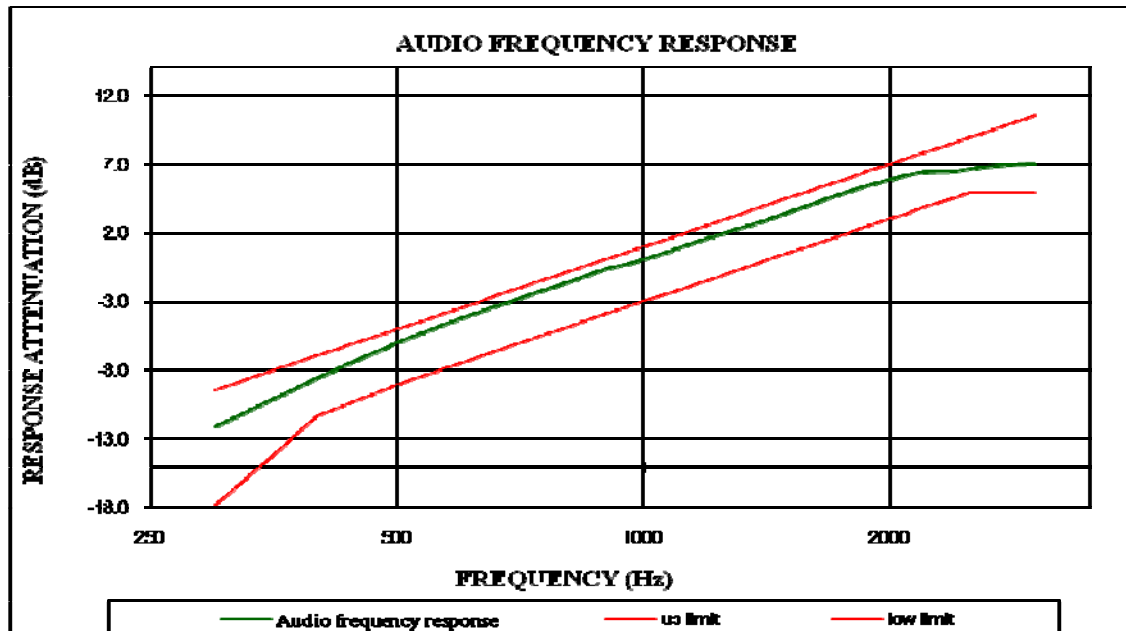

Audio Frequency Low Pass Filter Response

Carrier Frequency: 453.2125 MHz, Channel Spacing = 12.5 kHz, high power level

Audio Frequency	Response Attenuation	Limit
kHz	dB	dB
3.0	-2.5	0.0
3.5	-9.2	-6.7
4.0	-14.7	-12.5
5.0	-25.0	-22.2
7.0	-39.0	-36.8
10.0	-54.5	-52.3
15.0	-71.9	-69.9
20.0	-85.2	-82.5
30.0	-85.6	-82.5
50.0	-85.0	-82.5
70.0	-85.6	-82.5

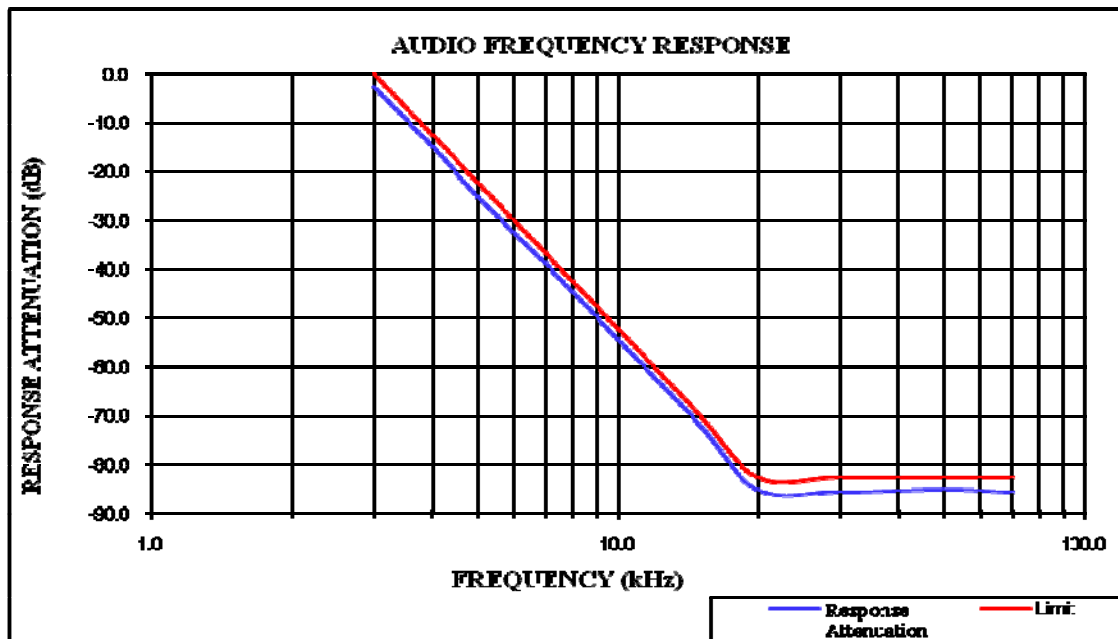

FCC §2.1049 & §22.357 & § 22.731 & §90.209 & §90.210 – OCCUPIED BANDWIDTH & EMISSION MASK

Applicable Standard

FCC §2.1049, §22.357, § 22.731, §90.209 and §90.210

Applicable Emission Masks

Frequency band (MHz)	Mask for equipment with audio low pass filter	Mask for equipment without audio low pass filter
Below 25	A or B	A or C
25-50	B	C
72-76	B	C
150-174	B, D, or E	C, D or E
150 paging only	B	C
220-222	F	F
421-512	B, D, or E	C, D, or E
450 paging only	B	G
806-809/851-854	B	H
809-824/854-869	B	G
896-901/935-940	I	J
902-928	K	K
929-930	B	G
4940-4990 MHz	L or M	L or M
5850-5925		
All other bands	B	C

Emission Mask D—12.5 kHz channel bandwidth equipment. For transmitters designed to operate with a 12.5 kHz channel bandwidth, any emission must be attenuated below the power (P) of the highest emission contained within the authorized bandwidth as follows:

(1) On any frequency from the center of the authorized bandwidth f_0 to 5.625 kHz removed from f_0 : Zero dB.

(2) On any frequency removed from the center of the authorized bandwidth by a displacement frequency (f_d in kHz) of more than 5.625 kHz but no more than 12.5 kHz: At least $7.27(f_d - 2.88 \text{ kHz})$ dB.

(3) On any frequency removed from the center of the authorized bandwidth by a displacement frequency (f_d in kHz) of more than 12.5 kHz: At least $50 + 10 \log(P)$ dB or 70 dB, whichever is the lesser attenuation.

(4) The reference level for showing compliance with the emission mask shall be established using a resolution bandwidth sufficiently wide (usually two or three times the channel bandwidth) to capture the true peak emission of the equipment under test. In order to show compliance with the emission mask up to and including 50 kHz removed from the edge of the authorized bandwidth, adjust the resolution bandwidth to 100 Hz with the measuring instrument in a peak hold mode. A sufficient number of sweeps must be measured to insure that the emission profile is developed. If video filtering is used, its bandwidth must not be less than the instrument resolution bandwidth. For emissions beyond 50 kHz from the edge of the authorized bandwidth, see paragraph (o) of this section. If it can be shown that use of the above instrumentation settings do not accurately represent the true interference potential of the equipment under test, an alternate procedure may be used provided prior Commission approval is obtained.

§22.357 Emission types.

Any authorized station in the Public Mobile Services may transmit emissions of any type(s) that comply with the applicable emission rule, i.e. §22.359, §22.861 or §22.917

§22.731 Emission limitations.

Upon application for multichannel operation, the FCC may authorize emission bandwidths wider than those specified in §22.357, provided that spectrum utilization is equal to or better than that achieved by single channel operation.

Test Equipment List and Details

Manufacturer	Description	Model No.	Serial No.	Calibration Date	Calibration Due Date
Rohde & Schwarz	Signal Analyzer	FSIQ26	831929/005	2016-09-21	2017-09-20
N/A	RF Attenuator	20dB	N/A	Each Time	/

* **Statement of Traceability:** BACL (Chengdu) attested that all calibrations have been performed, traceable to National Primary Standards and International System of Units (SI).

Test Procedure

The RF output of the transmitter was connected to the input of the spectrum analyzer through sufficient attenuation.

Test Data

Environmental Conditions

Temperature:	28.5 °C
Relative Humidity:	33 %
ATM Pressure:	101.3 kPa

The testing was performed by Lorin Bian from 2016-11-27.

Test Result: Compliant. Please refer to the following tables and plots.

FCC Part 90:

Modulation Mode	Channel Spacing	f _c	26 dB Bandwidth	99% Occupied Bandwidth	Power Level
		MHz	kHz	kHz	
FM	12.5 kHz	453.2125	10.220	10.020	High
			10.421	10.020	Low
4FSK	12.5 kHz		9.519	7.515	High
			9.519	7.415	Low

FCC Part 22:

Modulation Mode	Channel Spacing	f _c	26 dB Bandwidth	99% Occupied Bandwidth	Power Level
		MHz	kHz	kHz	
FM	12.5 kHz	454.0125	10.421	10.020	High
			10.421	10.020	Low
4FSK			9.920	7.715	High
			9.018	7.615	Low

Note: Emission bandwidth was based on calculation method instead of measurement.

Emission Designator

Per CFR 47 §2.201& §2.202, BW = 2M + 2D

For FM Mode (Channel Spacing: 12.5 kHz)

Emission Designator 11K0F3E

In this case, the maximum modulating frequency is 3.0 kHz with a 2.5 kHz deviation.

$BW = 2(M+D) = 2*(3.0 \text{ kHz} + 2.5 \text{ kHz}) = 11 \text{ kHz} = 11K0$

F3E portion of the designator represents an FM voice transmission

Therefore, the entire designator for 12.5 kHz channel spacing FM mode is 11K0F3E.

For Digital Mode (Channel Spacing: 12.5 kHz)

Emission Designator 7K60F1D and 7K60F1E

The 99% energy rule (title 47CFR 2.1049) was used for digital mode. It basically states that 99% of the modulation energy falls within X kHz, in this case, 7.60 kHz. The emission mask was obtained from 47CFR 90.210(d).

F1D and F1E portion of the designator indicates digital information.

Therefore, the entire designator for 12.5 kHz channel spacing digital mode is 7K60F1D and 7K60F1E.

Part 90:

Occupied Bandwidth – FM, 453.2125 MHz, High Power Level

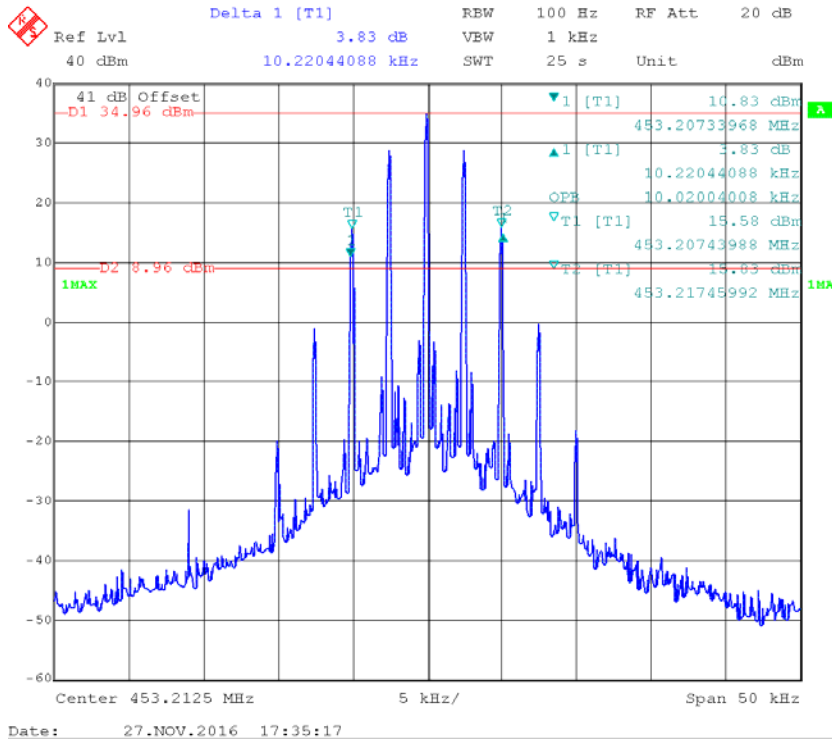

Emission Mask - Type D

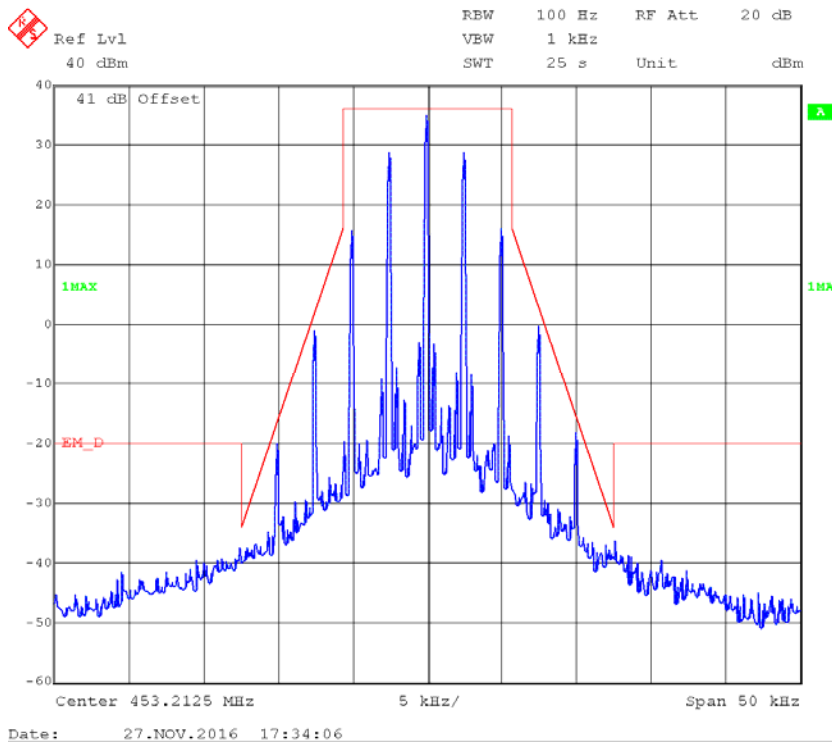

Occupied Bandwidth – FM, 453.2125 MHz, Low Power Level

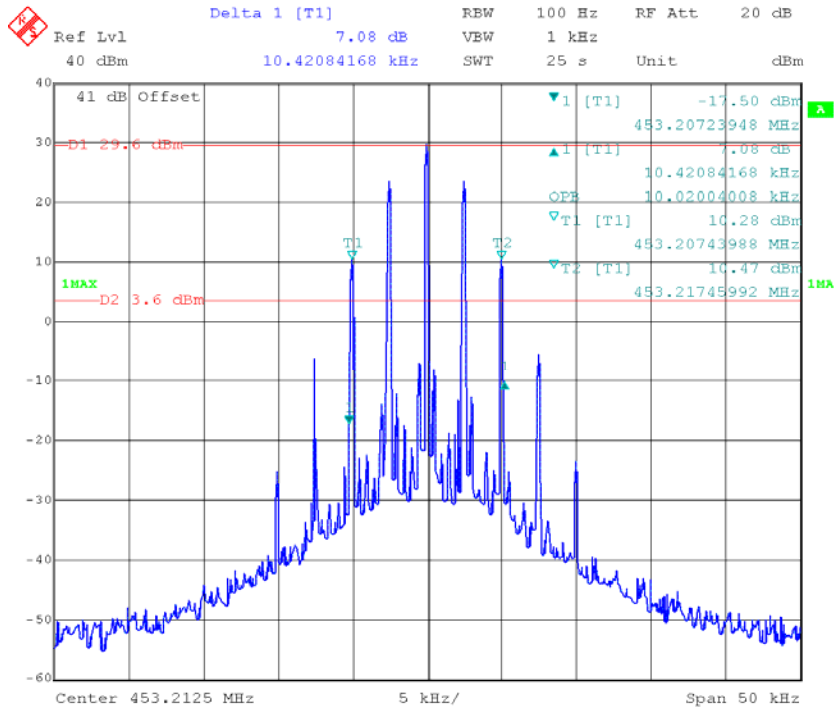

Emission Mask - Type D

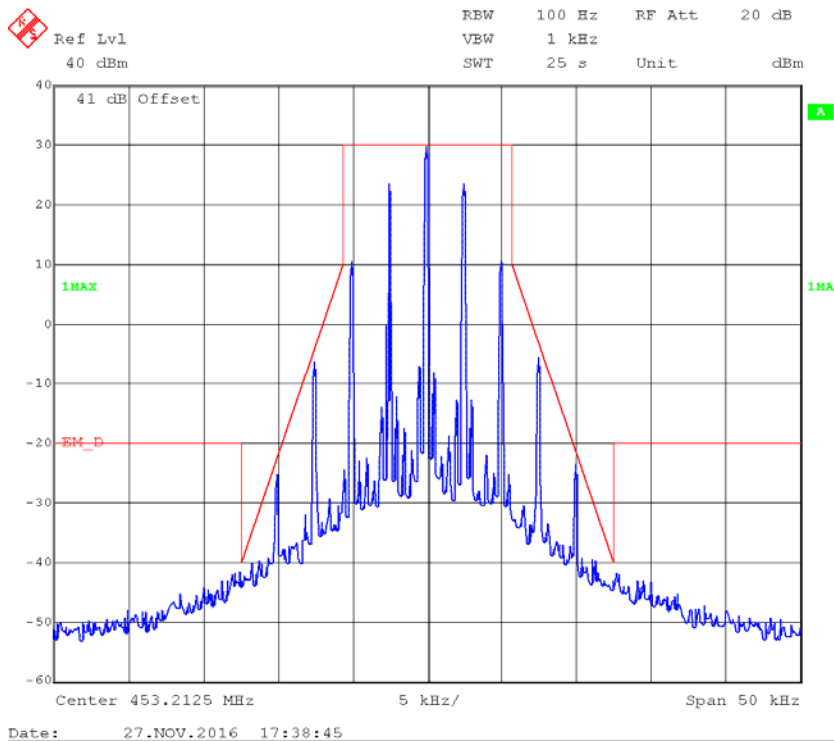

Occupied Bandwidth – 4FSK, 453.2125 MHz, High Power Level

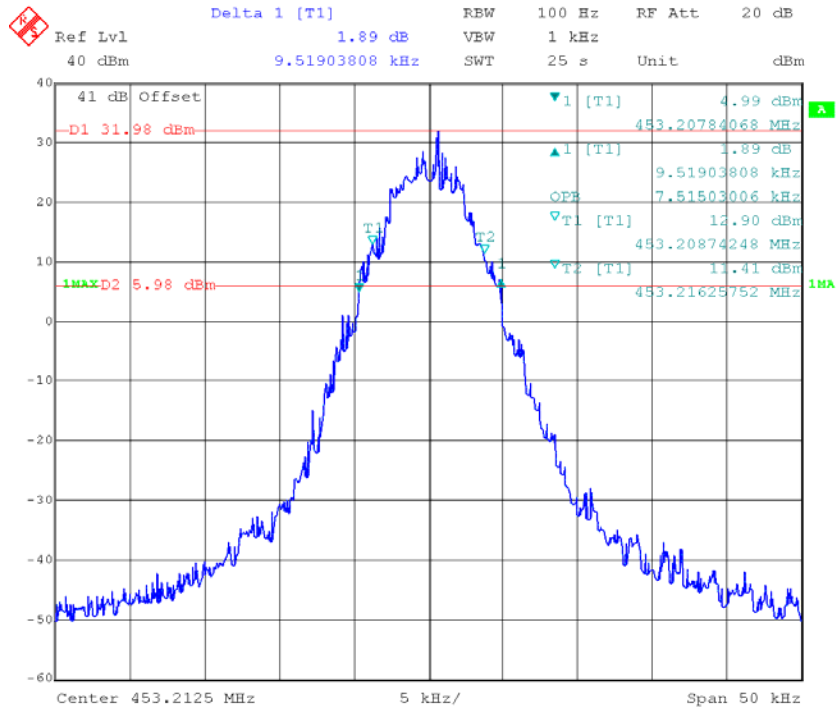

Emission Mask - Type D

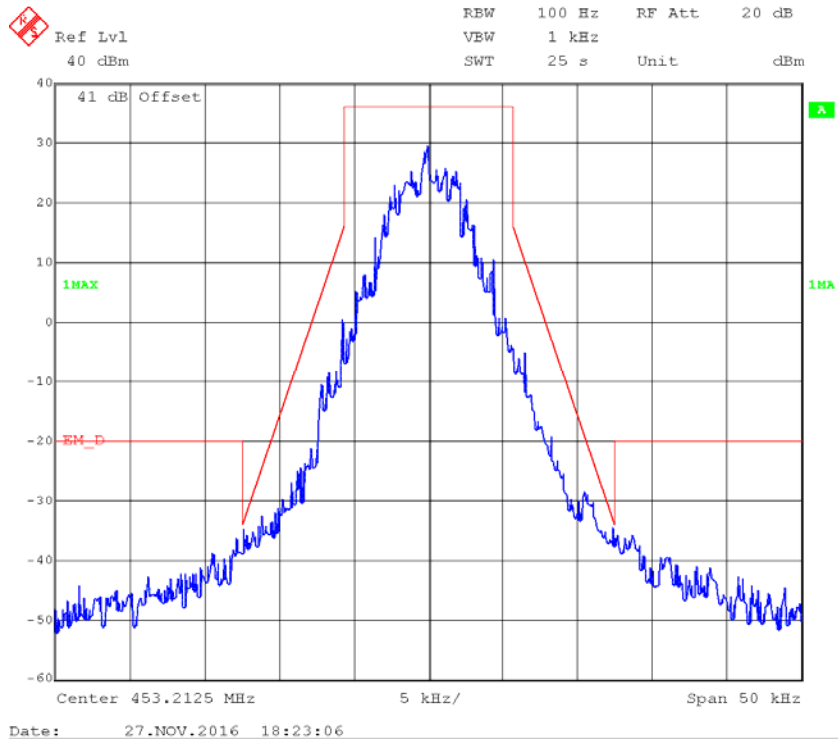

Occupied Bandwidth – 4FSK, 453.2125 MHz, Low Power Level

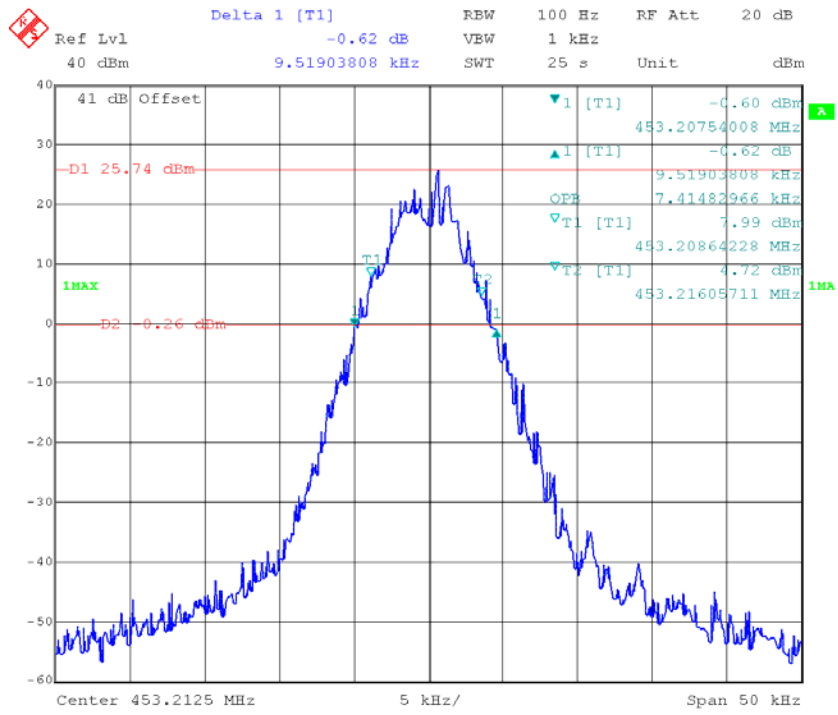

Emission Mask - Type D

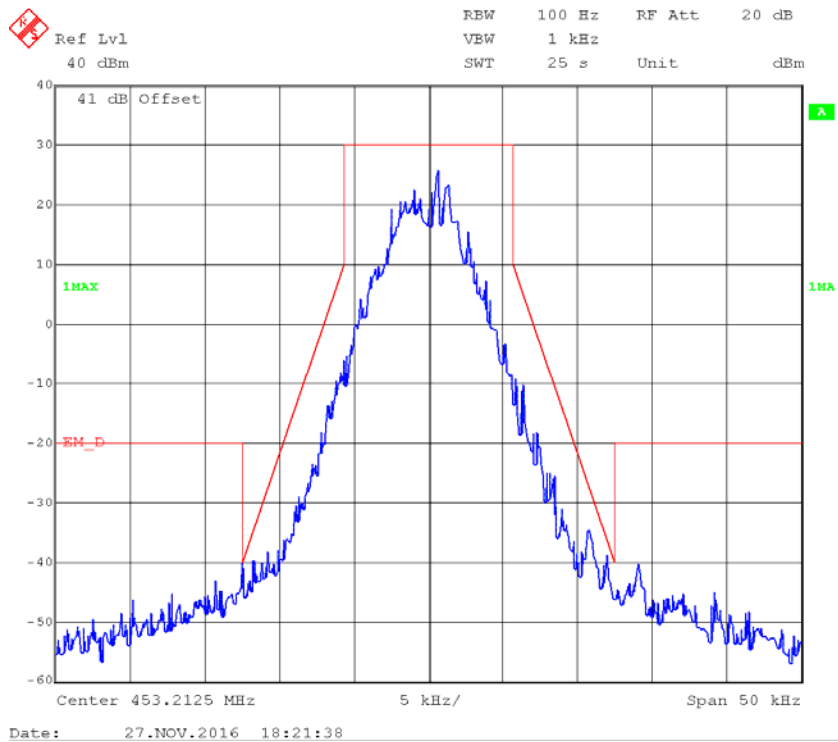

Part 22:

Occupied Bandwidth – FM, 454.0125 MHz, High Power Level

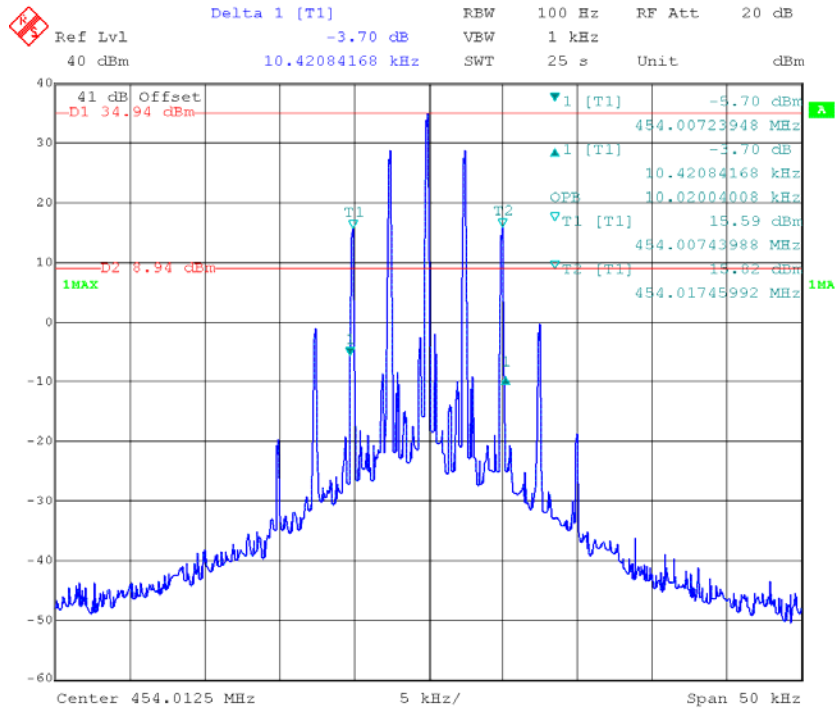

Occupied Bandwidth – FM, 454.0125 MHz, Low Power Level

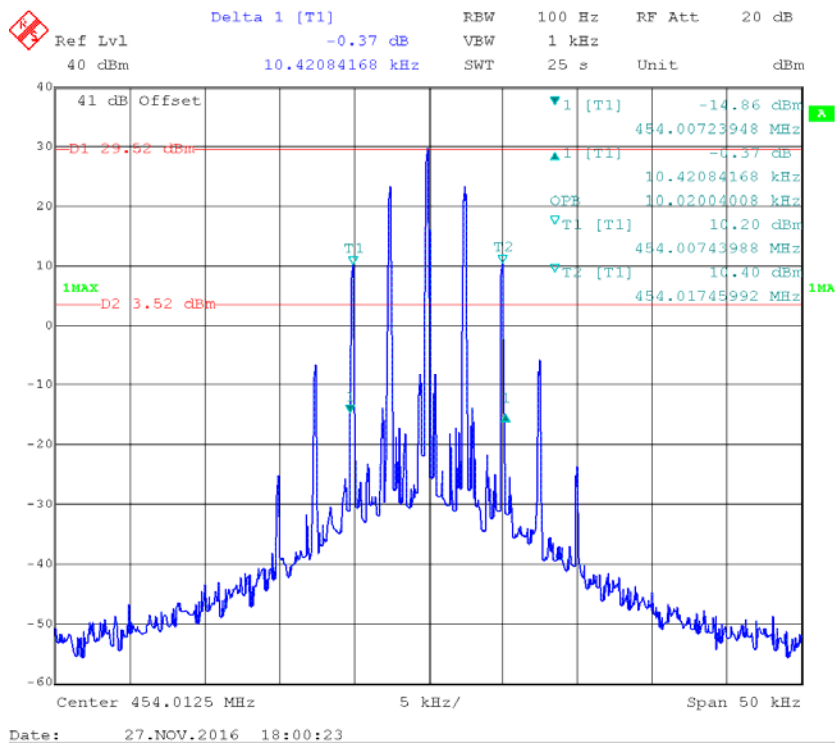

Occupied Bandwidth – 4FSK, 454.0125 MHz, High Power Level

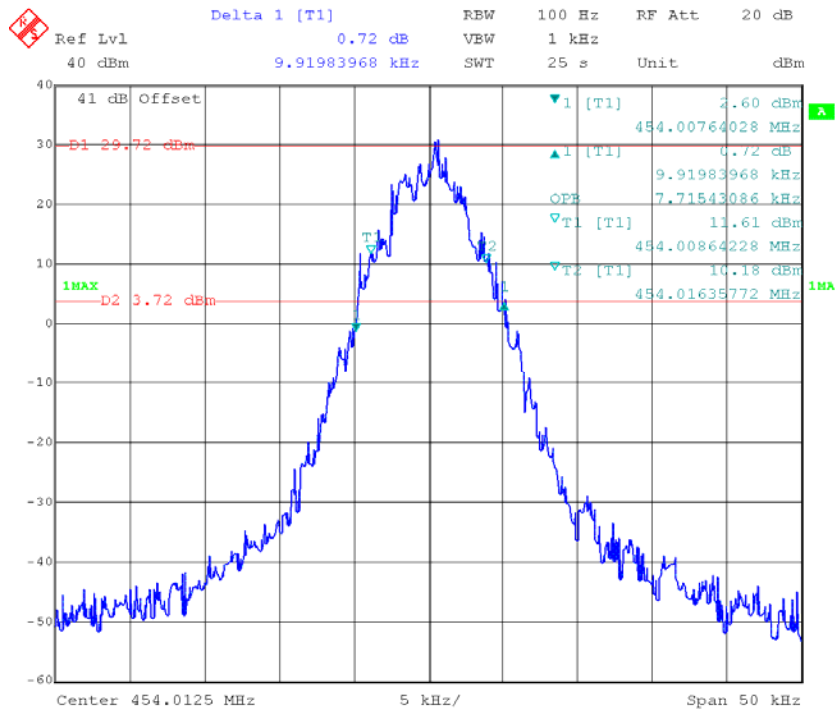

Occupied Bandwidth – 4FSK, 454.0125 MHz, Low Power Level

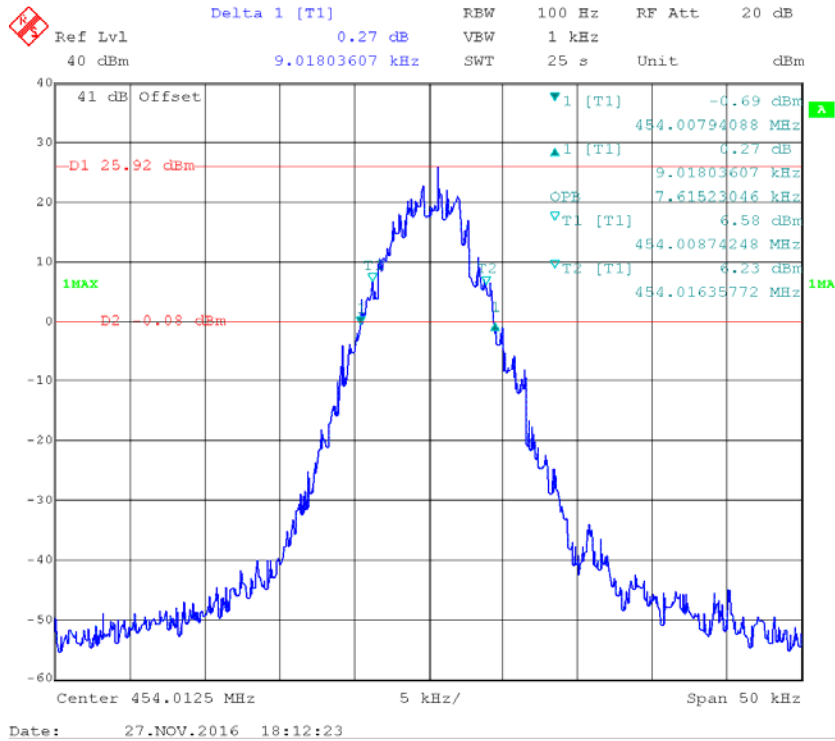

FCC §2.1051 & §22.861 & §90.210 - SPURIOUS EMISSIONS AT ANTENNA TERMINALS

Applicable Standard

Emission Mask D—12.5 kHz channel bandwidth equipment. For transmitters designed to operate with a 12.5 kHz channel bandwidth, any emission must be attenuated below the power (P) of the highest emission contained within the authorized bandwidth as follows:

(1) On any frequency from the center of the authorized bandwidth f_0 to 5.625 kHz removed from f_0 : Zero dB.

(2) On any frequency removed from the center of the authorized bandwidth by a displacement frequency (f_d in kHz) of more than 5.625 kHz but no more than 12.5 kHz: At least $7.27(f_d - 2.88 \text{ kHz})$ dB.

(3) On any frequency removed from the center of the authorized bandwidth by a displacement frequency (f_d in kHz) of more than 12.5 kHz: At least $50 + 10 \log(P)$ dB or 70 dB, whichever is the lesser attenuation.

(4) The reference level for showing compliance with the emission mask shall be established using a resolution bandwidth sufficiently wide (usually two or three times the channel bandwidth) to capture the true peak emission of the equipment under test. In order to show compliance with the emission mask up to and including 50 kHz removed from the edge of the authorized bandwidth, adjust the resolution bandwidth to 100 Hz with the measuring instrument in a peak hold mode. A sufficient number of sweeps must be measured to insure that the emission profile is developed. If video filtering is used, its bandwidth must not be less than the instrument resolution bandwidth. For emissions beyond 50 kHz from the edge of the authorized bandwidth, see paragraph (o) of this section. If it can be shown that use of the above instrumentation settings do not accurately represent the true interference potential of the equipment under test, an alternate procedure may be used provided prior Commission approval is obtained.

§22.861 Emission limitations.

(a) Out of band emissions. The power of any emission outside of the authorized operating frequency ranges must be attenuated below the transmitting power (P) by a factor of at least $43 + 10 \log(P)$ dB.

Test Equipment List and Details

Manufacturer	Description	Model No.	Serial No.	Calibration Date	Calibration Due Date
Rohde & Schwarz	Signal Analyzer	FSIQ26	831929/005	2016-09-21	2017-09-20
N/A	RF Attenuator	20dB	N/A	Each Time	/
N/A	RF Attenuator	20dB	N/A	Each Time	/

* **Statement of Traceability:** BACL (Chengdu) attested that all calibrations have been performed, traceable to National Primary Standards and International System of Units (SI).

Test Procedure

Adjust the spectrum analyzer for the following settings:

- 1) Resolution Bandwidth = 100 kHz for spurious emissions below 1 GHz, and 1 MHz for spurious emissions above 1 GHz.
- 2) Video Bandwidth ≥ 3 times the resolution bandwidth.
- 3) Sweep Speed ≤ 2000 Hz per second.
- 4) Detector Mode = peak.

Test Data

Environmental Conditions

Temperature:	28.5 °C
Relative Humidity:	33 %
ATM Pressure:	101.3 kPa

The testing was performed by Lorin Bian from 2016-11-27

FCC PART 90 453.2125 MHz – FM Mode, High Power

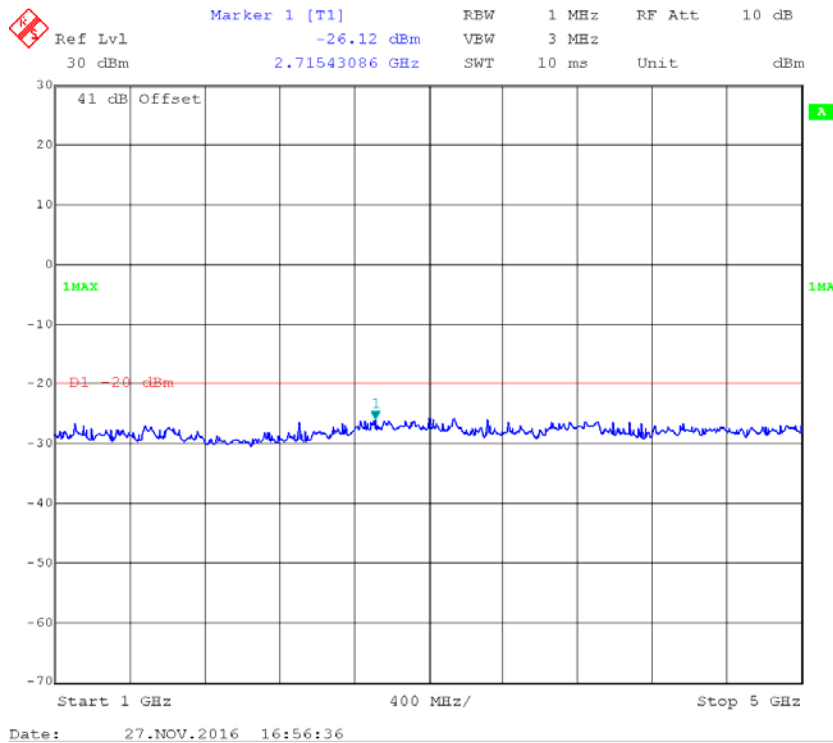
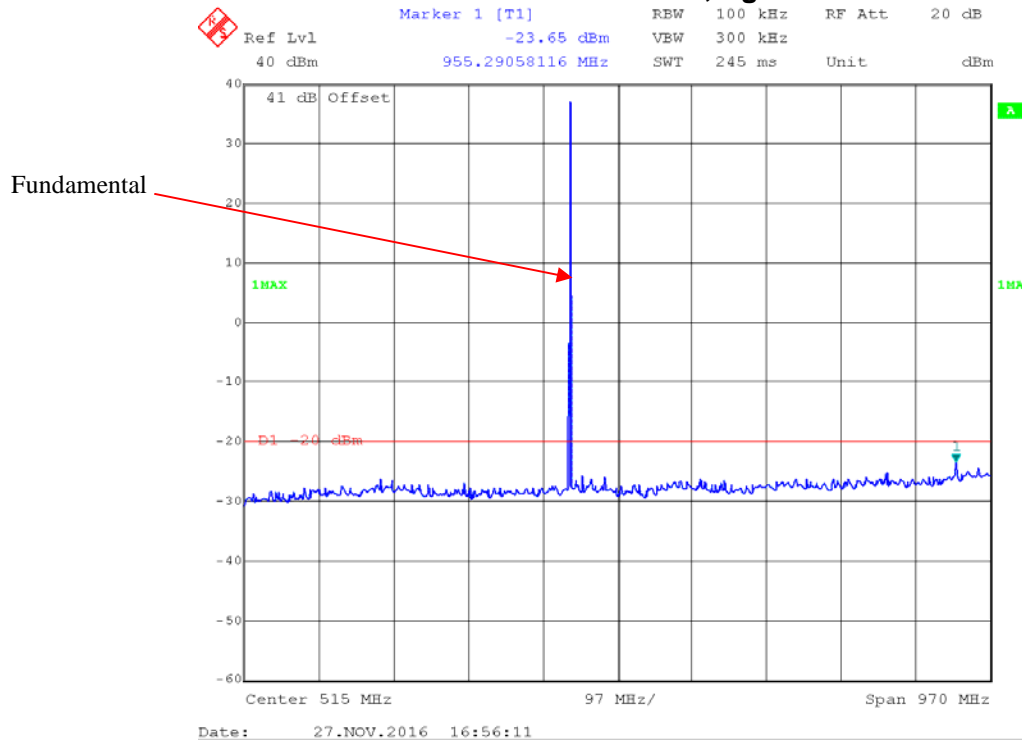

FCC PART 90 453.2125 MHz -4FSK Mode, High Power

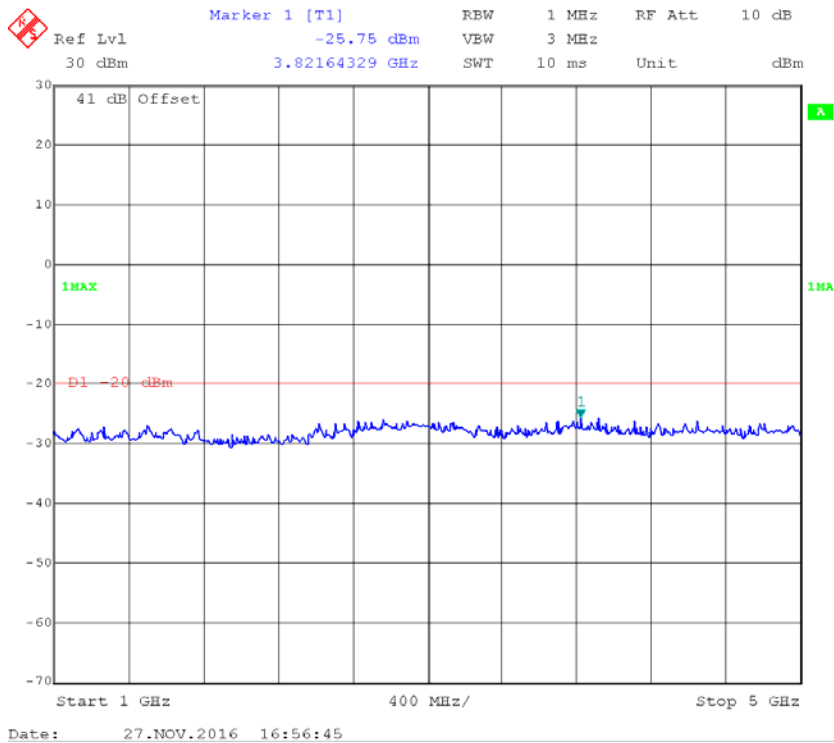
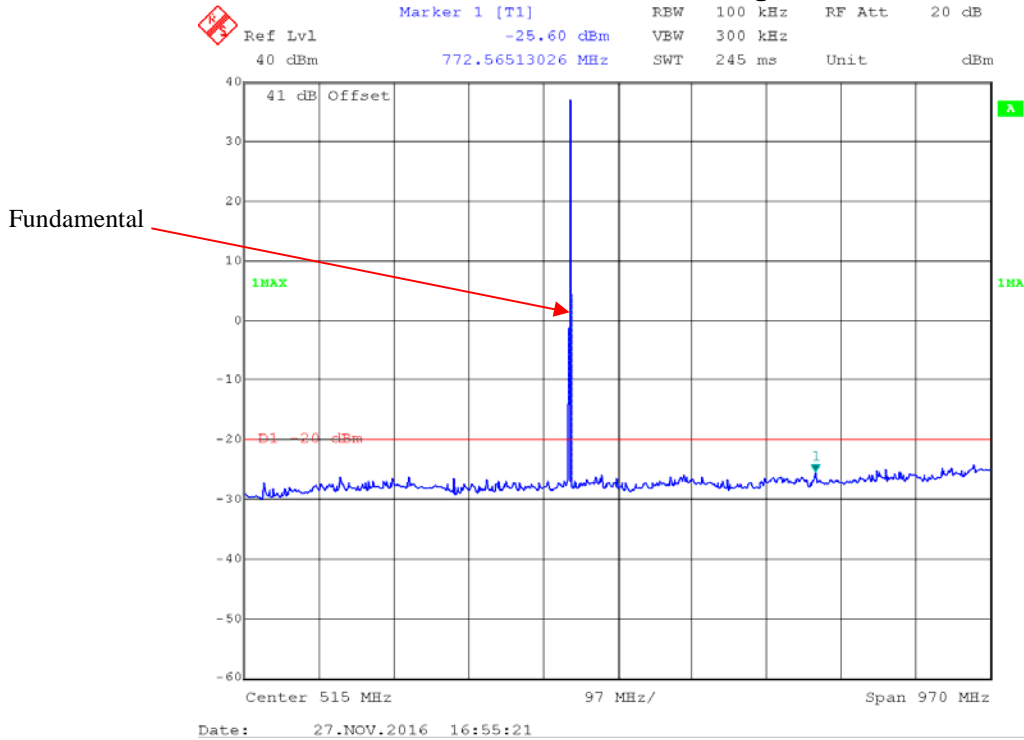

FCC PART 22 454.0125 MHz –FM Mode,High Power

Marker 1 [T1] RBW 100 kHz RF Att 20 dB
Ref Lvl -24.56 dBm VBW 300 kHz
40 dBm 976.67334669 MHz SWT 245 ms Unit dBm

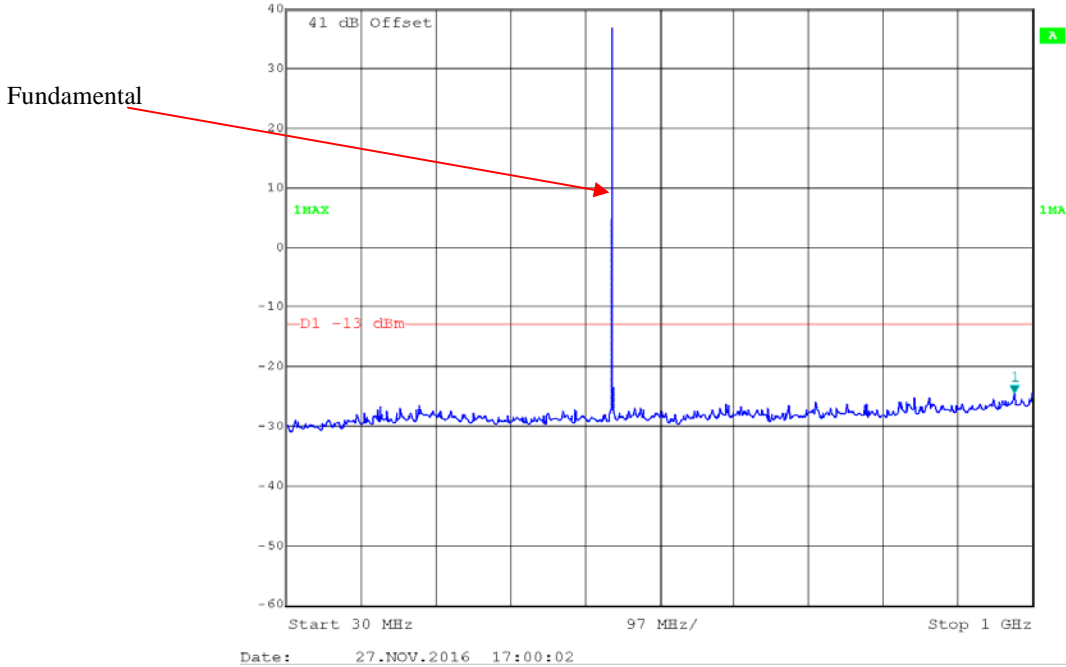

Marker 1 [T1] RBW 1 MHz RF Att 10 dB
Ref Lvl -26.05 dBm VBW 3 MHz
30 dBm 3.05210421 GHz SWT 10 ms Unit dBm

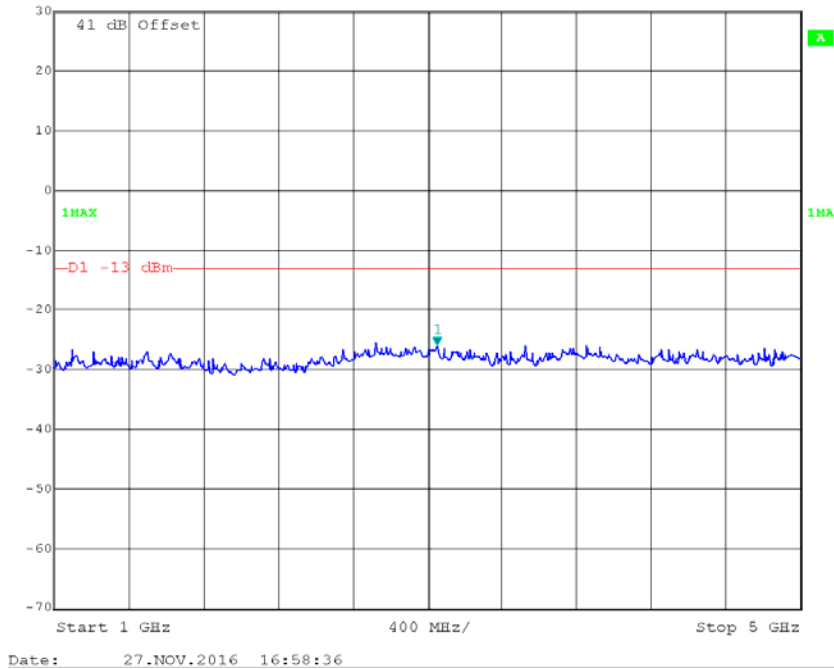

FCC PART 22 454.0125 MHz – 4FSK Mode, High Power

Marker 1 [T1] RBW 100 kHz RF Att 20 dB
Ref Lvl -25.17 dBm VBW 300 kHz
40 dBm 877.53507014 MHz SWT 245 ms Unit dBm

Fundamental

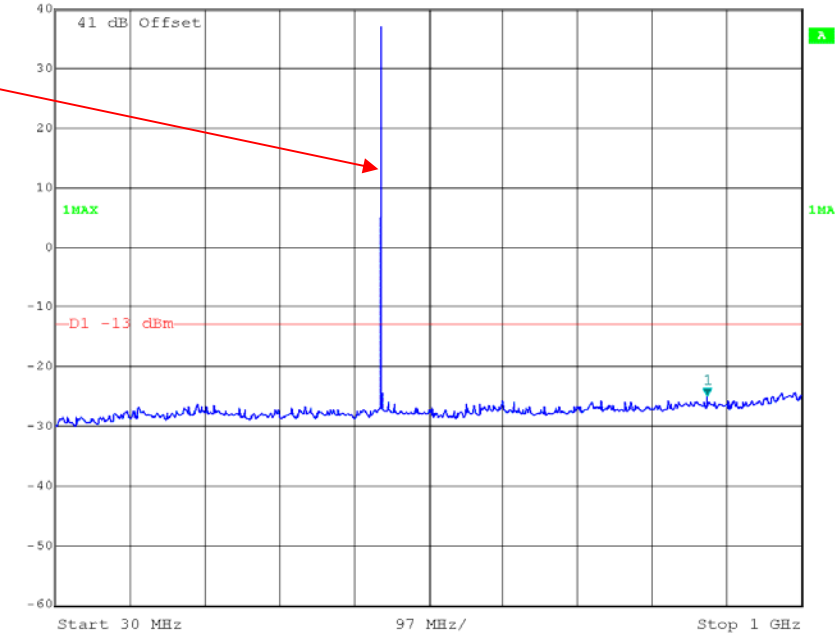

Date: 27.NOV.2016 16:59:46

Marker 1 [T1] RBW 1 MHz RF Att 10 dB
Ref Lvl -25.28 dBm VBW 3 MHz
30 dBm 2.76352705 GHz SWT 10 ms Unit dBm

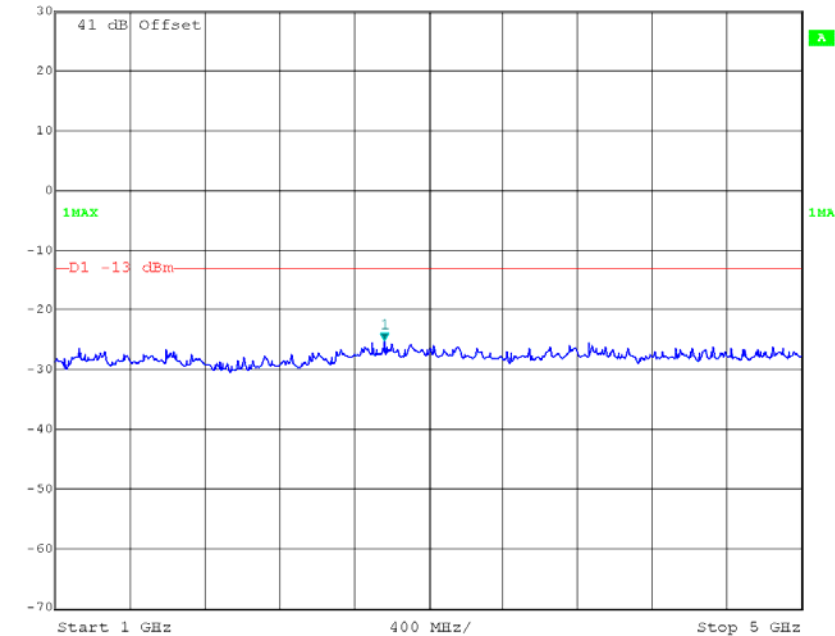

Date: 27.NOV.2016 16:58:29

FCC §2.1053 & §22.861 & §90.210 - RADIATED SPURIOUS EMISSIONS

Applicable Standard

FCC §2.1053 and §22.861 and §90.210

Test Equipment List and Details

Manufacturer	Description	Model	Serial Number	Calibration Date	Calibration Due Date
Agilent	Amplifier	8447D	2944A10442	2015-12-02	2016-12-01
Rohde & Schwarz	EMI Test Receiver	ESCI	100028	2015-12-02	2016-12-01
Sunol Sciences	Broadband Antenna	JB3	A101808	2016-04-10	2019-04-09
Rohde & Schwarz	Spectrum Analyzer	FSEM30	100018	2015-12-02	2016-12-01
ETS	Horn Antenna	3115	003-6076	2015-12-02	2016-12-01
Ducommun Technologies	Horn Antenna	ARH-4223-02	1007726-0113024	2014-6-16	2017-6-15
EMCO	Adjustable Dipole Antenna	3121C	9109-258	N/A	N/A
HP	Signal Generator	8648C	3623A04150	2016-5-23	2017-5-22
WILTRON	SWEPT FREQUENCY SYNTHESIZER	6737	213001	2016-5-23	2017-5-22
Mini-circuits	Amplifier	ZVA-183-S+	771001215	2016-05-20	2017-05-19
EMCT	Semi-Anechoic Chamber	966	N/A	2015-04-24	2018-04-23
N/A	RF Cable (below 1GHz)	NO.1	N/A	2015-11-10	2016-11-09
N/A	RF Cable (below 1GHz)	NO.4	N/A	2015-11-10	2016-11-09
N/A	RF Cable (above 1GHz)	NO.2	N/A	2015-11-10	2016-11-09

* **Statement of Traceability:** BACL (Chengdu) attested that all calibrations have been performed, traceable to National Primary Standards and International System of Units (SI).

Test Procedure

The transmitter was placed on a wooden turntable, and it was transmitting into a non-radiating load, which was also placed on the turntable.

The measurement antenna was placed at a distance of 3 meters from the EUT. During the tests, the antenna height and polarization as well as EUT azimuth were varied in order to identify the maximum level of emissions from the EUT. The test was performed by placing the EUT on 3-orthogonal axis.

The frequency range up to teeth harmonic of the fundamental frequency was investigated.

Remove the EUT and replace it with substitution antenna. A signal generator was connected to the substitution antenna by a non-radiating cable. The absolute levels of the spurious emissions were measured by the substitution.

For part 90:

Spurious emissions in dB = $10 \lg(\text{TXpwr in Watts}/0.001)$ - the absolute level

Spurious attenuation limit in dB = $50 + 10 \lg_{10}(\text{power out in Watts})$ for EUT with a 12.5 kHz channel bandwidth.

For part 22:

The power of any emission outside of the authorized operating frequency ranges must be attenuated below the transmitting power (P) by a factor of at least $43 + 10 \lg(P)$ dB.

Test Data

Environmental Conditions

Temperature:	26.7 °C
Relative Humidity:	31%
ATM Pressure:	101.2 kPa

The testing was performed by Lorin Bian on 2016-11-08.

Test Mode: Transmitting (FM mode, high power level)

Frequency	Polar	S.A. Reading	S.G. Level	Antenna Gain	Cable Loss	Absolute Level	Limit	Margin
MHz	H/V	dBµV	dBm	dBd/dBi	dB	dBm	dBm	dB
Frequency: 453.2125 MHz, for FCC PART 90								
906.425	H	62.84	-42.5	0.0	0.6	-43.1	-20.0	23.1
906.425	V	63.79	-36.7	0.0	0.6	-37.3	-20.0	17.3
1359.638	H	37.62	-65.2	7.2	0.8	-58.8	-20.0	38.8
1359.638	V	33.54	-68.6	7.2	0.8	-62.2	-20.0	42.2
1812.85	H	54.44	-45.7	8.0	0.9	-38.6	-20.0	18.6
1812.85	V	52.64	-46.7	8.0	0.9	-39.6	-20.0	19.6
2266.063	H	44.67	-55.1	8.5	1.4	-48.0	-20.0	28.0
2266.063	V	46.69	-49.9	8.5	1.4	-42.8	-20.0	22.8
2719.275	H	52.49	-46.7	8.8	1.1	-39.0	-20.0	19.0
2719.275	V	59.49	-38.8	8.8	1.1	-31.1	-20.0	11.1
3172.488	H	48.74	-48.3	8.7	1.2	-40.8	-20.0	20.8
3172.488	V	56.36	-41	8.7	1.2	-33.5	-20.0	13.5
3625.7	H	33.88	-62.1	8.8	1.3	-54.6	-20.0	34.6
3625.7	V	34.57	-61.7	8.8	1.3	-54.2	-20.0	34.2
4078.913	H	50.32	-44.7	9.0	1.6	-37.3	-20.0	17.3
4078.913	V	52.05	-43	9.0	1.6	-35.6	-20.0	15.6
4532.125	H	46.28	-49.2	10.2	1.6	-40.6	-20.0	20.6
4532.125	V	48.37	-47	10.2	1.6	-38.4	-20.0	18.4
Frequency: 454.0125 MHz, for FCC PART 22								
908.025	H	65.24	-40	0.0	0.6	-40.6	-13.0	27.6
908.025	V	66.28	-34.2	0.0	0.6	-34.8	-13.0	21.8
1362.038	H	32.58	-70.3	7.2	0.8	-63.9	-13.0	50.9
1362.038	V	35.83	-66.3	7.2	0.8	-59.9	-13.0	46.9
1816.05	H	52.77	-47.3	8.0	0.9	-40.2	-13.0	27.2
1816.05	V	52.27	-47	8.0	0.9	-39.9	-13.0	26.9
2270.063	H	44.31	-55.5	8.5	1.4	-48.4	-13.0	35.4
2270.063	V	45.88	-50.7	8.5	1.4	-43.6	-13.0	30.6
2724.075	H	52.3	-46.9	8.8	1.1	-39.2	-13.0	26.2
2724.075	V	59.44	-38.9	8.8	1.1	-31.2	-13.0	18.2
3178.088	H	48.7	-48.3	8.7	1.2	-40.8	-13.0	27.8
3178.088	V	55.41	-41.9	8.7	1.2	-34.4	-13.0	21.4
3632.1	H	32.57	-63.3	8.8	1.3	-55.8	-13.0	42.8
3632.1	V	34.22	-62	8.8	1.3	-54.5	-13.0	41.5
4086.113	H	42.58	-52.5	9.0	1.6	-45.1	-13.0	32.1
4086.113	V	47.34	-47.7	9.0	1.6	-40.3	-13.0	27.3
4540.125	H	42.2	-53.2	10.2	1.6	-44.6	-13.0	31.6
4540.125	V	44.69	-50.7	10.2	1.6	-42.1	-13.0	29.1

Test Mode: Transmitting (4FSK mode, high power level)

Frequency	Polar	S.A. Reading	S.G. Level	Antenna Gain	Cable Loss	Absolute Level	Limit	Margin
MHz	H/V	dB μ V	dBm	dBd/dBi	dB	dBm	dBm	dB
Frequency: 453.2125 MHz, for FCC PART 90								
906.425	H	65.85	-39.5	0.0	0.6	-40.1	-20.0	20.1
906.425	V	66.69	-33.8	0.0	0.6	-34.4	-20.0	14.4
1359.638	H	39.4	-63.5	7.2	0.8	-57.1	-20.0	37.1
1359.638	V	41.37	-60.8	7.2	0.8	-54.4	-20.0	34.4
1812.85	H	51.73	-48.4	8.0	0.9	-41.3	-20.0	21.3
1812.85	V	51.59	-47.7	8.0	0.9	-40.6	-20.0	20.6
2266.063	H	46.56	-53.2	8.5	1.4	-46.1	-20.0	26.1
2266.063	V	47.57	-49.1	8.5	1.4	-42.0	-20.0	22.0
2719.275	H	53.05	-46.2	8.8	1.1	-38.5	-20.0	18.5
2719.275	V	58.87	-39.5	8.8	1.1	-31.8	-20.0	11.8
3172.488	H	50.61	-46.4	8.7	1.2	-38.9	-20.0	18.9
3172.488	V	54.82	-42.5	8.7	1.2	-35.0	-20.0	15.0
3625.7	H	32.24	-63.7	8.8	1.3	-56.2	-20.0	36.2
3625.7	V	35.06	-61.2	8.8	1.3	-53.7	-20.0	33.7
4078.913	H	47.26	-47.7	9.0	1.6	-40.3	-20.0	20.3
4078.913	V	49.63	-45.4	9.0	1.6	-38.0	-20.0	18.0
4532.125	H	45.22	-50.2	10.2	1.6	-41.6	-20.0	21.6
4532.125	V	47.59	-47.8	10.2	1.6	-39.2	-20.0	19.2
Frequency: 454.0125 MHz, for FCC PART 22								
908.025	H	64.3	-41	0.0	0.6	-41.6	-13.0	28.6
908.025	V	65.69	-34.8	0.0	0.6	-35.4	-13.0	22.4
1362.038	H	31.47	-71.4	7.2	0.8	-65.0	-13.0	52.0
1362.038	V	34.62	-67.5	7.2	0.8	-61.1	-13.0	48.1
1816.05	H	52.71	-47.4	8.0	0.9	-40.3	-13.0	27.3
1816.05	V	50.82	-48.5	8.0	0.9	-41.4	-13.0	28.4
2270.063	H	45.98	-53.8	8.5	1.4	-46.7	-13.0	33.7
2270.063	V	49.5	-47.1	8.5	1.4	-40.0	-13.0	27.0
2724.075	H	54.83	-44.4	8.8	1.1	-36.7	-13.0	23.7
2724.075	V	59.11	-39.2	8.8	1.1	-31.5	-13.0	18.5
3178.088	H	50.33	-46.7	8.7	1.2	-39.2	-13.0	26.2
3178.088	V	54.94	-42.4	8.7	1.2	-34.9	-13.0	21.9
3632.1	H	31.84	-64	8.8	1.3	-56.5	-13.0	43.5
3632.1	V	33.25	-63	8.8	1.3	-55.5	-13.0	42.5
4086.113	H	46.25	-48.8	9.0	1.6	-41.4	-13.0	28.4
4086.113	V	50.74	-44.3	9.0	1.6	-36.9	-13.0	23.9
4540.125	H	43.65	-51.8	10.2	1.6	-43.2	-13.0	30.2
4540.125	V	44.73	-50.7	10.2	1.6	-42.1	-13.0	29.1

Note:

- 1) The unit of Antenna Gain is dBd for frequency below 1GHz, and the unit of Antenna Gain is dBi for frequency above 1GHz.
- 2) Absolute Level = SG Level - Cable loss + Antenna Gain
- 3) Margin = Limit-Absolute Level

FCC §2.1055 & § 22.355 & §90.213- FREQUENCY STABILITY

Applicable Standard

FCC §2.1055, § 22.355, §90.213

Test Equipment List and Details

Manufacturer	Description	Model No.	Serial No.	Calibration Date	Calibration Due Date
BACL	High Temperature Test Chamber	BTH-150	30024	2015-12-2	2016-12-1
FLUKE	Multimeter	1587	27870099	2015-12-30	2016-12-29
Rohde & Schwarz	Signal Analyzer	FSIQ26	831929/005	2016-09-21	2017-09-20
N/A	RF Attenuator	20dB	N/A	Each Time	/

* **Statement of Traceability:** BACL (Chengdu) attested that all calibrations have been performed, traceable to National Primary Standards and International System of Units (SI).

Test Procedure

Frequency Stability vs. Temperature: The equipment under test was connected to DC power supply and the RF output was connected to a frequency counter via feed-through attenuators. The EUT was placed inside the temperature chamber. The power leads and RF output cable exited the chamber through an opening made for the purpose.

After the temperature stabilized for approximately 20 minutes, the frequency output was recorded from the counter.

The frequency stability shall be measured with variation of primary supply voltage as follows:

- (1) Vary primary supply voltage from 85 to 115 percent of the nominal value.
- (2) For hand carried, battery powered equipment, reduce primary supply voltage to the battery operating end point which shall be specified by the manufacturer.

Test Data

Environmental Conditions

Temperature:	26.7 °C
Relative Humidity:	36%
ATM Pressure:	101.5kPa

The testing was performed by Lorin Bian on 2016-11-20.

Test Mode: Transmitting

FCC PART 90:

Reference Frequency: 453.2125 MHz, Limit: 2.5 ppm			
Temperature	Voltage	Measured	Frequency Error
°C	V _{DC}	MHz	ppm
-30	7.4	453.212424	-0.17
-20		453.212454	-0.10
-10		453.212441	-0.13
0		453.212458	-0.09
10		453.212420	-0.18
20		453.212428	-0.16
30		453.212432	-0.15
40		453.212445	-0.12
50		453.212439	-0.13
60		453.212437	-0.14
25		6.7	453.212416
25	7.4	453.212441	-0.13

FCC PART 22:

Reference Frequency: 454.0125 MHz, Limit: 2.5 ppm			
Temperature	Voltage	Measured	Frequency Error
°C	V _{DC}	MHz	ppm
-30	7.4	454.012420	-0.18
-20		454.012420	-0.18
-10		454.012421	-0.17
0		454.012424	-0.17
10		454.012442	-0.13
20		454.012424	-0.17
30		454.012437	-0.14
40		454.012455	-0.10
50		454.012427	-0.16
60		454.012421	-0.17
25	6.7	454.012414	-0.19
25	7.4	454.012433	-0.15

Note: The extreme voltage is declared by the manufacturer.

FCC §90.214 - TRANSIENT FREQUENCY BEHAVIOR

Applicable Standard

Regulations: FCC §90.214

Test method: ANSI/TIA-603-D 2010, section 2.2.19.3

Test Equipment List and Details

Manufacturer	Description	Model No.	Serial No.	Calibration Date	Calibration Due Date
Rohde & Schwarz	Signal Analyzer	FSIQ26	831929/005	2016-09-21	2017-09-20
HP	RF Communications Test Set	8920A	00 247	2016-08-10	2017-08-10
N/A	RF Attenuator	20dB	N/A	Each Time	/

* **Statement of Traceability:** BACL (Chengdu) attested that all calibrations have been performed, traceable to National Primary Standards and International System of Units (SI).

Test Procedure

- a) Connect the EUT and test equipment as shown on the following block diagram.
- b) Set the Spectrum Analyzer to measure FM deviation, and tune the RF frequency to the transmitter assigned frequency.
- c) Set the signal generator to the assigned transmitter frequency and modulate it with a 1 kHz tone at ± 12.5 kHz deviation and set its output level to -100dBm.
- d) Turn on the transmitter.
- e) Supply sufficient attenuation via the RF attenuator to provide an input level to the Spectrum Analyzer that is 40 dB below the maximum allowed input power when the transmitter is operating at its rated power level. Note this power level on the Spectrum Analyzer as P_0 .
- f) Turn off the transmitter.
- g) Adjust the RF level of the signal generator to provide RF power equal to P_0 . This signal generator RF level shall be maintained throughout the rest of the measurement.
- h) Remove the attenuation 1, so the input power to the Spectrum Analyzer is increased by 30 dB when the transmitter is turned on.
- i) Adjust the vertical amplitude control of the spectrum analyzer to display the 1000 Hz at ± 4 divisions vertically centered on the display. Set trigger mode of the Spectrum Analyzer to "Video", and tune the "trigger level" on suitable level. Then set the "trigger offset" to -10ms for turn on and -15ms for turn off.
- j) Turn on the transmitter and the transient wave will be captured on the screen of Spectrum Analyzer. Observe the stored display. The instant when the 1 kHz test signal is completely suppressed is considered to be t_{on} . The trace should be maintained within the allowed divisions during the period t_1 and t_2 .

- k) Then turn off the transmitter, and another transient wave will be captured on the screen of Spectrum Analyzer. The trace should be maintained within the allowed divisions during the period t_3 .

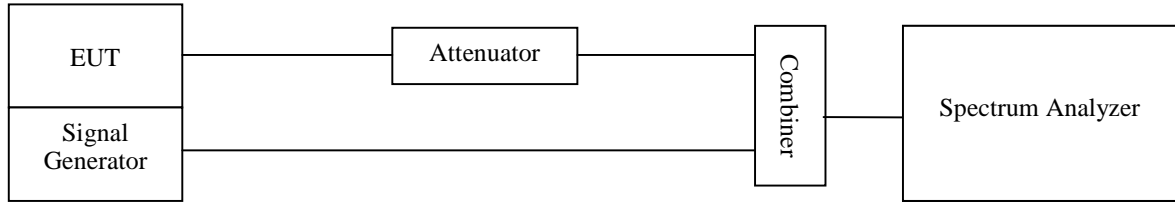

Test Data

Environmental Conditions

Temperature:	28.5 °C
Relative Humidity:	33%
ATM Pressure:	101.3 kPa

The testing was performed by Lorin Bian on 2016-11-27.

Channel Spacing (kHz)	Transient Period (ms)	Maximum frequency difference	Result
12.5	$<10(t_1)$	± 12.5 kHz	Pass
	$<25(t_2)$	± 6.25 kHz	
	$<10(t_3)$	± 12.5 kHz	

Please refer to the following plots.

Turn on – 453.2125 MHz, High power level

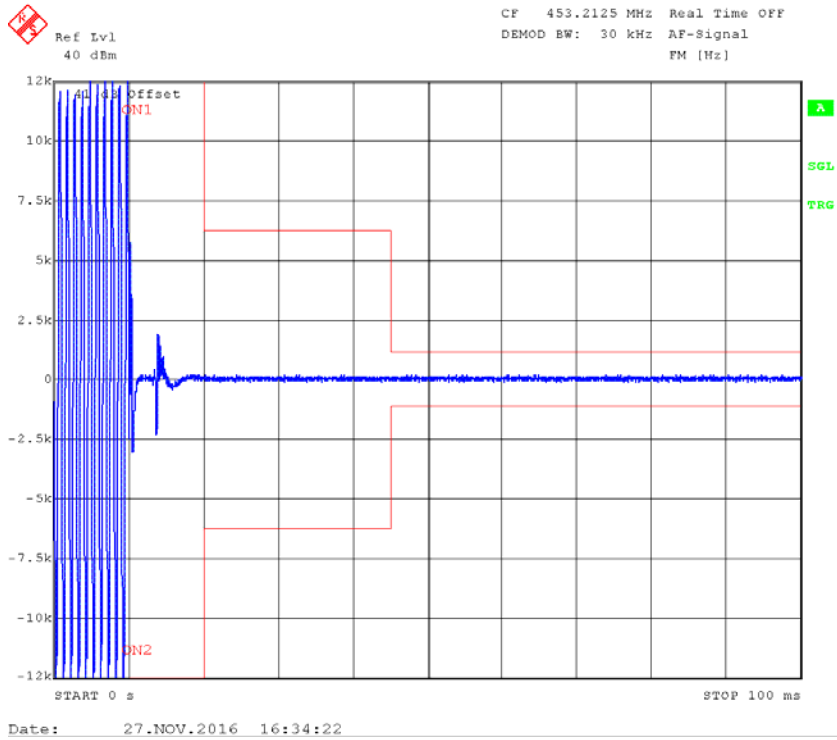

Turn off – 453.2125 MHz, High power level

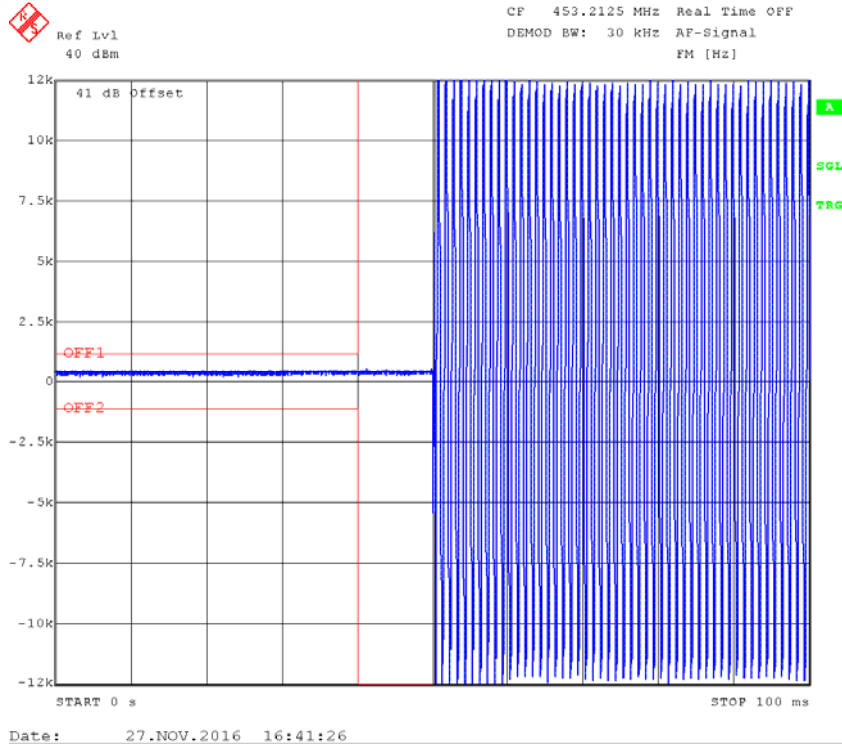

***** END OF REPORT *****