

---

# FCC Part 90& RSS-119

## Test Report

---

Report No.: AGC12111011SZ16-2F1

**TEST NAME** : FCC Part 90  
**FCC ID** : Y4GCU600-2  
**IC ID** : 9415A-CU6002  
**PRODUCT DESIGNATION** : Two way radio  
**BRAND NAME** : COVALUE  
**TEST MODEL NAME** : CU600-2  
**CLIENT** : SHENZHEN COVALUE COMMUNICATIONS CO., LTD.  
**DATE OF ISSUE** : Dec.20, 2010  
**STANDARD(S)** : FCC Part 90 Rules

Attestation of **Global Compliance Co., Ltd.**

CAUTION: This report shall not be reproduced except in full without the written permission of the test laboratory and shall not be quoted out of context.

## VERIFICATION OF COMPLIANCE

Applicant:	SHENZHEN COVALUE COMMUNICATIONS CO., LTD.
	Rm 408,Water Group Building, No.5 KYLIN Road, Nanshan District, Shenzhen, China
Manufacturer:	SHENZHEN COVALUE COMMUNICATIONS CO., LTD.
	Rm 408,Water Group Building, No.5 KYLIN Road, Nanshan District, Shenzhen, China
Product Description:	Two way radio
Brand Name:	COVALUE
Model Name:	CU600-2
Model difference:	N/A
File Number:	AGC12111011SZ16-2F1
Date of Test:	Dec.08 to Dec.20, 2010

### We hereby certify that:

The above equipment was tested by Attestation of Global Compliance Co., Ltd. The data evaluation, test procedures, and equipment configurations shown in this report were made in accordance with the procedures given in ANSI C 63.4:2003 and TIA/EIA 603. The sample tested as described in this report is in compliance with the FCC Rules Part 90 and RS-119 requirements.

The test results of this report relate only to the tested sample identified in this report.

Checked By: Jekey Zhang  
Jekey Zhang      Dec.20, 2010

Authorized By King Zhang  
King Zhang      Dec.20, 2010

## TABLE OF CONTENTS

<b>1. GENERAL INFORMATION</b> .....	<b>4</b>
1.1 PRODUCT DESCRIPTION.....	4
1.3 TEST METHODOLOGY .....	5
1.4 TEST FACILITY .....	5
1.5 SPECIAL ACCESSORIES .....	5
1.6 EQUIPMENT MODIFICATIONS.....	5
<b>2. SYSTEM TEST CONFIGURATION</b> .....	<b>6</b>
2.1 EUT CONFIGURATION.....	6
2.2 EUT EXERCISE.....	6
2.3 GENERAL TECHNICAL REQUIREMENTS.....	6
2.4 CONFIGURATION OF TESTED SYSTEM.....	6
<b>3. SUMMARY OF TEST RESULTS</b> .....	<b>7</b>
<b>4. DESCRIPTION OF TEST MODES</b> .....	<b>8</b>
<b>5. CONDUCTED LIMITS</b> .....	<b>9</b>
5.1 PROVISIONS APPLICABLE.....	9
5.2 MEASUREMENT PROCEDURE.....	9
5.3 TEST SETUP BLOCK DIAGRAM.....	10
5.4 TEST EQUIPMENT USED .....	10
5.5 TEST RESULT .....	11
<b>6. FREQUENCY TOLERANCE</b> .....	<b>13</b>
6.1 PROVISIONS APPLICABLE.....	13
6.2 MEASUREMENT PROCEDURE.....	13
6.3 TEST SETUP BLOCK DIAGRAM.....	14
6.4 TEST EQUIPMENT USED: .....	14
6.5 TEST RESULT .....	14
<b>7. EMISSION BANDWIDTH</b> .....	<b>21</b>
7.1 PROVISIONS APPLICABLE.....	21
7.2 MEASUREMENT PROCEDURE.....	21
7.3 TEST SETUP BLOCK DIAGRAM.....	21
7.4 MEASUREMENT EQUIPMENT USED: .....	21
7.5 MEASUREMENT RESULT: .....	22
<b>8. UNWANTED RADIATION</b> .....	<b>24</b>
8.1 PROVISIONS APPLICABLE.....	24
8.2 MEASUREMENT PROCEDURE.....	24

8.3 TEST SETUP BLOCK DIAGRAM.....	25
8.4 MEASUREMENT EQUIPMENT USED:.....	27
8.5 MEASUREMENT RESULTS:.....	27
8.6 EMISSION MASK PLOT .....	30
<b>9. MODULATION CHARACTERISTICS .....</b>	<b>32</b>
9.1 PROVISIONS APPLICABLE.....	32
9.2 MEASUREMENT METHOD .....	32
9.3 MEASUREMENT INSTRUMENTS.....	32
9.4 MEASUREMENT RESULT.....	33
10.1 PROVISIONS APPLICABLE.....	39
10.2 TEST PROCEDURE.....	39
10.3 TEST INSTRUMENTS.....	39
10.4 TEST RESULT.....	40
10.4 CONDUCT SPURIOUS PLOT .....	41
<b>11. TRANSMITTER FREQUENCY BEHAVIOR .....</b>	<b>44</b>
11.1 PROVISIONS APPLICABLE .....	44
11.2 TEST METHOD .....	44
11.3 TEST INSTRUMENTS .....	44
<b>12. RADIATED EMISSION ON RECEIVING MODE .....</b>	<b>49</b>
12.1 PROVISIONS APPLICABLE .....	49
12.2 TEST METHOD.....	49
12.3 TEST INSTRUMENTS .....	49
12.4 MEASURE RESULT (MEASURED AT 3M USING FCC PART15 B LIMITS).....	50
<b>13. AUDIO LOW PASS FILTER RESPONSE .....</b>	<b>52</b>
13.1 LIMITS .....	52
13.2. METHOD OF MEASUREMENTS.....	52
13.3 TEST DATA .....	52
<b>APPENDIX I.....</b>	<b>57</b>
<b>PHOTOGRAPHS OF SETUP .....</b>	<b>57</b>
<b>APPENDIX II.....</b>	<b>59</b>
<b>EXTERNAL VIEW OF EUT.....</b>	<b>59</b>

## 1. GENERAL INFORMATION

### 1.1 PRODUCT DESCRIPTION

The EUT is a single channel Two-way Radio designed for voice communication. It is designed by way of utilizing the FM modulation achieves the system operating.

A major technical description of EUT is described as following:

Communication Type	Voice / Tone only
Modulation	FM
Emission Type	F3E
Emission Bandwidth	10.42kHz/15.43kHz (Limite:11.25KHz/20KHz)
Peak Frequency Deviation	0.369 KHz for 12.5 KHz Channel Separation (Limit $\leq$ $\pm$ 2.5 KHz)
	0.428 KHz for 25 KHz Channel Separation (Limit $\leq$ $\pm$ 5 KHz)
Maximum Transmitter Power	36.43dBm for 12.5 KHz Channel Separation
	36.44dBm for 25.0KHz Channel Separation
Output power Modification	4W (It was fixed by the manufacturer, any individual can't arbitrarily change it)
Antenna Designation	Detachable
Power Supply	DC 7.4V by battery
Battery Endpoint	DC 7.4V
Operation Frequency Range and Channel	Frequency Range:400MHz to 470MHz Channel Separation: 12.5KHz and 25KHz
	Top Channel: 469.965MHz, Centre Channel: 450.1MHz, Bottom Channel: 406.2MHz,
Frequency Tolerance	0.908ppm for 12.5 KHz Channel Separation 1.054 ppm for 25.0 KHz Channel Separation
Transmitter Spurious (Worst case)	-34.31dBm

## **1.2 RELATED SUBMITTAL(S) / GRANT (S)**

This submittal(s) (test report) is intended for FCC ID: Y4GCU600-2 and IC ID: 9415A-CU6002, filing to comply with the FCC Part 90 and RS-119 requirements.

## **1.3 TEST METHODOLOGY**

The radiated emission testing was performed according to the procedures of ANSI C 63.4: 2009; TIA/EIA 603 and FCC CFR 47 Rules of 2.1046, 2.1047, 2.1049, 2.1051, 2.1053, 2.1055, 2.1057.

## **1.4 TEST FACILITY**

The test site used to collect the radiated data is located on the address of Attestation of Global Compliance Co., Ltd. 2F., No.2 Building, Huafeng No.1 Technical Industrial Park, Sanwei, Xixiang, Baoan District, Shenzhen. The test site is constructed and calibrated to meet the FCC requirements in documents ANSI C63.4: 2003 and IC requirements in documents RS212.

FCC register No.: 259865

## **1.5 SPECIAL ACCESSORIES**

Not available for this EUT intended for grant.

## **1.6 EQUIPMENT MODIFICATIONS**

Not available for this EUT intended for grant.

## 2. SYSTEM TEST CONFIGURATION

### 2.1 EUT CONFIGURATION

The EUT configuration for testing is installed on RF field strength measurement to meet the Commission’s requirement and operating in a manner which intends to maximize its emission characteristics in a continuous normal application.

### 2.2 EUT EXERCISE

The Transmitter was operated in the normal operating mode. The TX frequency was fixed which was for the purpose of the measurements.

### 2.3 GENERAL TECHNICAL REQUIREMENTS

- (1). Section 15.207: Conducted Limits
- (2). Section 90.205: Maximum ERP is dependent upon the station’s antenna HAAT and required service area
- (3). Section 90.207: Modulation Characteristic
- (4). Section 90.209: Occupied Bandwidth
- (5). Section 90.210: Emission Mask
- (6). Section 90.213: Frequency Tolerance
- (7). Section 90.214: Transient Frequency Behavior
- (8). Section 15.109: Radiated Emission

### 2.4 CONFIGURATION OF TESTED SYSTEM

Fig. 2-1 Configuration of Tested System



Table 2-1 Equipment Used in Tested System

Item	Equipment	Model No.	Identifier	Note
1	Two way Radio	CU600-2	FCC ID: Y4GCU600-2 IC ID: 9415A-CU6002	EUT
2	--	--	--	--
--	--	--	--	--

### 3. SUMMARY OF TEST RESULTS

<b>FCC Rules</b>	<b>RS-119</b>	<b>Description Of Test</b>	<b>Result</b>
§15.207	RS-Gen	Conducted Emission	Compliant
§90.205	§5.4	Maximum Transmitter Power	Compliant
§90.207	§5.13	Modulation Characteristic	Compliant
§90.209	§5.5	Occupied Bandwidth	Compliant
§90.210	§5.8	Emission Mask	Compliant
§90.213	§5.3	Frequency Tolerance	Compliant
§90.214	§5.9	Transient Frequency Behavior	Compliant
§15.109	RS-Gen	Radiated Emission	Compliant



#### **4. DESCRIPTION OF TEST MODES**

The EUT (Handheld two way radio) has been tested under normal operating condition. (The top channel, the middle channel and the bottom channel) are chosen for testing at each channel separation (12.5 KHz/ 25 KHz).

## 5. CONDUCTED LIMITS

### 5.1 PROVISIONS APPLICABLE

For an intentional radiator that is designed to be connected to the public utility (AC) power line, the, the radio frequency voltage that is conducted back onto the AC power line on any frequencies within the band 150 KHz to 30 MHz shall not exceed the limits in the following table, as measured using a 50uH/50 ohms line impedance stabilization network (LISN). Compliance with the provisions of this paragraph shall be based on the measurement of the radio frequency voltage between each power line and ground at the power terminal. The lower limit applies at the boundary between the frequencies ranges.

Frequency of Emission (MHz)	Conducted Limit(dBuV)	
	Quasi-Peak	Average
0.15 – 0.5	66 to 56 *	56 to 46 *
0.5 – 5	56	46
5 – 30	60	50

\* Decreases with the logarithm of the frequency.

### 5.2 MEASUREMENT PROCEDURE

- (1) The equipment was set up as per the test configuration to simulate typical actual usage per the user's manual. When the EUT is a tabletop system, a wooden table with a height of 0.8 meters is used and is placed on the ground plane as per ANSI C63.4 (see Test Facility for the dimensions of the ground plane used). When the EUT is a floor-standing equipment, it is placed on the ground plane which has a 3-12 mm non-conductive covering to insulate the EUT from the ground plane.
- (2) Support equipment, if needed, was placed as per ANSI C63.4.
- (3) All I/O cables were positioned to simulate typical actual usage as per ANSI C63.4.
- (4) The EUT received AC120V/60Hz power through a Line Impedance Stabilization Network (LISN) which supplied power source and was grounded to the ground plane.
- (5) All support equipments received AC power from a second LISN, if any.
- (6) The EUT test program was started. Emissions were measured on each current carrying line of the EUT using a spectrum Analyzer / Receiver connected to the LISN powering the EUT. The LISN has two monitoring points: Line 1 (Hot Side) and Line 2 (Neutral Side). Two scans were taken: one with Line 1 connected to Analyzer / Receiver and Line 2 connected to a 50 ohm load; the second scan had Line 1 connected to a 50 ohm load and Line 2 connected to the Analyzer / Receiver.
- (7) Analyzer / Receiver scanned from 150kHz to 30MHz for emissions in each of the test modes.  
During the above scans, the emissions were maximized by cable manipulation.

**5.3 TEST SETUP BLOCK DIAGRAM**

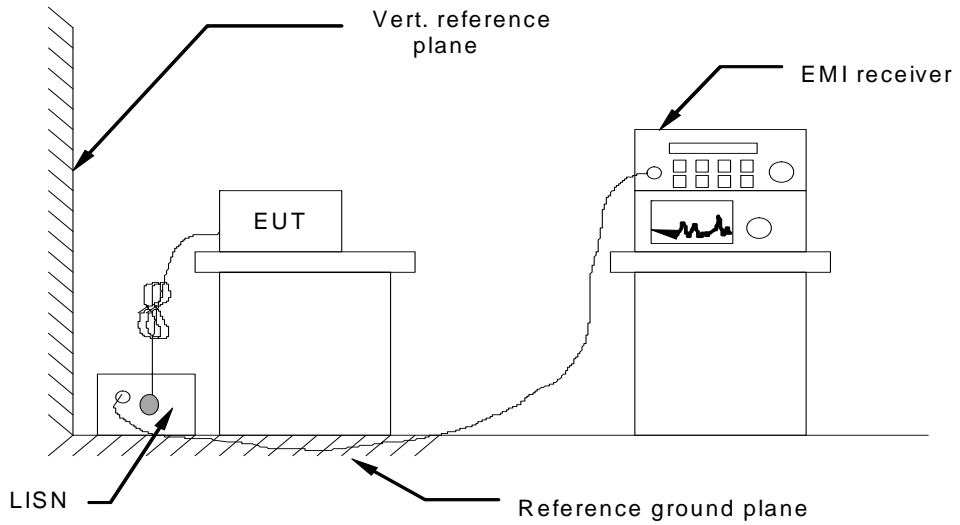

**5.4 TEST EQUIPMENT USED**

Conducted Emission Test Site				
Name of Equipment	Manufacturer	Model	Serial Number	Cal. Date
TEST RECEIVER	R&S	FCKL1528	A0304230	2010.06
LISN	SCHWARZBECK	NSLK8127	A0304233	2010.06

5.5 TEST RESULT

LINE CONDUCTED EMISSION TEST-L

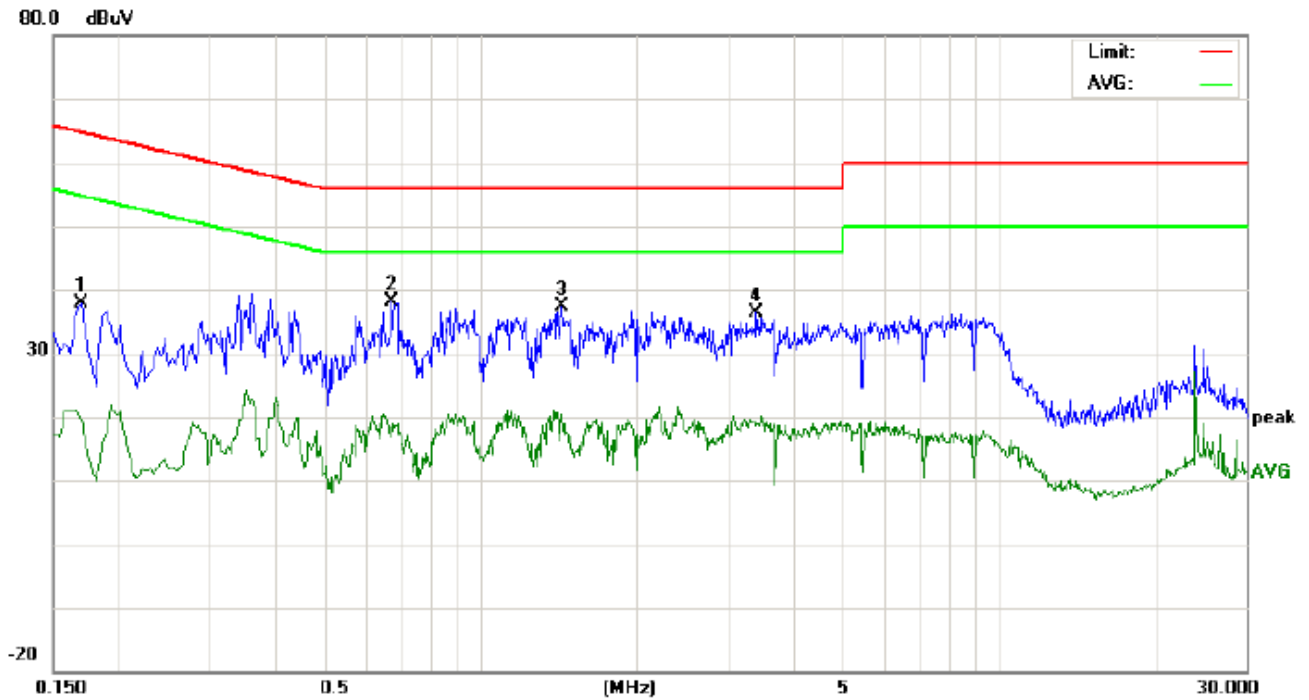

Site: Conduction  
 Limit: FCC Class B Conduction(QP)  
 EUT: Two way radio  
 M/N: CU600-2  
 Mode: CHARGE  
 Note:

Phase: L1  
 Power: AC 120V/60Hz

Temperature: 26  
 Humidity: 60 %

No.	Freq. (MHz)	Reading_Level (dBuV)			Correct Factor (dB)	Measurement (dBuV)			Limit (dBuV)		Margin (dB)		P/F	Comment
		Peak	QP	AVG		Peak	QP	AVG	QP	AVG	QP	AVG		
1	0.1700	27.67		9.21	10.18	37.85		19.39	64.96	54.96	-27.11	-35.57	P	
2	0.6740	27.90		7.75	10.34	38.24		18.09	56.00	46.00	-17.76	-27.91	P	
3	1.4338	27.00		9.93	10.38	37.38		20.31	56.00	46.00	-18.62	-25.69	P	
4	3.4020	25.88		8.11	10.52	36.40		18.63	56.00	46.00	-19.60	-27.37	P	

LINE CONDUCTED EMISSION TEST-N

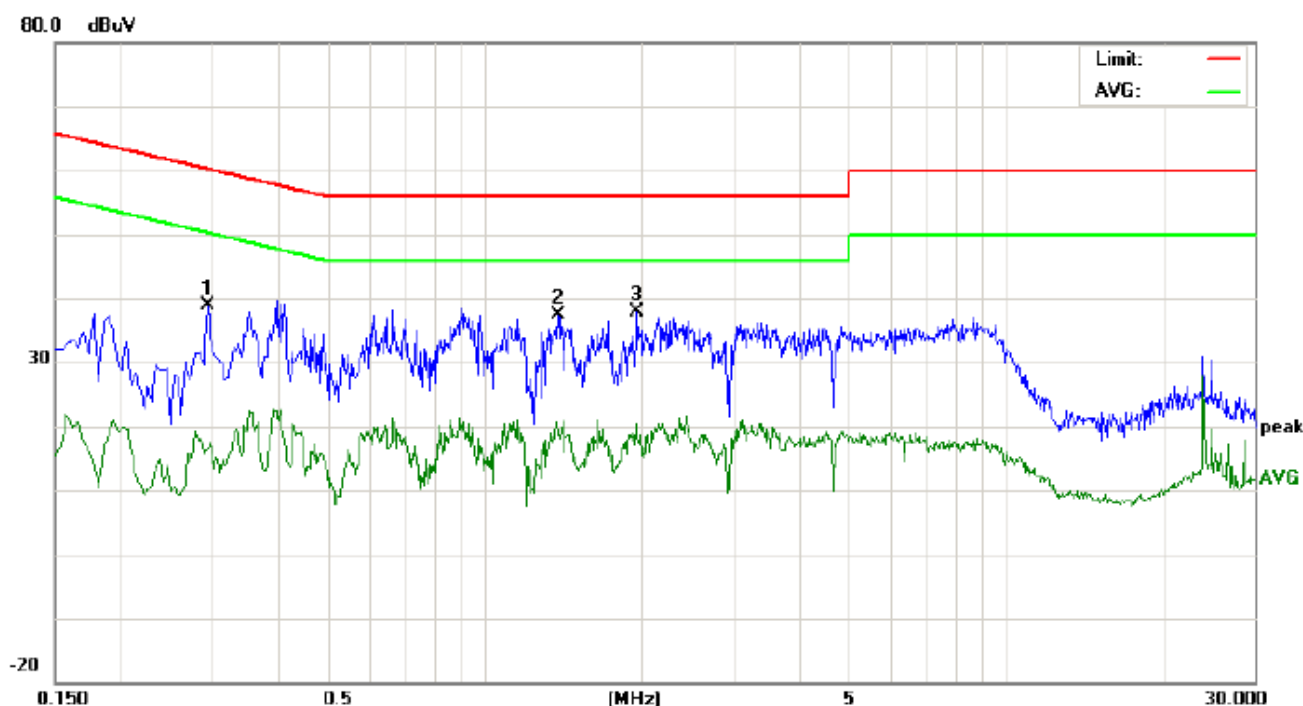

Site: Conduction Phase: **N** Temperature: 26  
 Limit: FCC Class B Conduction(QP) Power: AC 120V/60Hz Humidity: 60 %  
 EUT: Two way Radio  
 M/N: CU600-2  
 Mode: CHARGE  
 Note:

No.	Freq. (MHz)	Reading_Level (dBuV)			Correct Factor (dB)	Measurement (dBuV)			Limit (dBuV)		Margin (dB)		P/F	Comment
		Peak	QP	AVG		Peak	QP	AVG	QP	AVG	QP	AVG		
1	0.2940	28.68		6.44	10.29	38.97	16.73	60.41	50.41	-21.44	-33.68	P		
2	1.3820	26.87		8.81	10.38	37.25	19.19	56.00	46.00	-18.75	-26.81	P		
3	1.9620	27.57		8.32	10.23	37.80	18.55	56.00	46.00	-18.20	-27.45	P		

## 6. FREQUENCY TOLERANCE

### 6.1 PROVISIONS APPLICABLE

- a). According to FCC Part 2 Section 2.1055(a)(1), the frequency stability shall be measured with variation of ambient temperature from  $-30^{\circ}\text{C}$  to  $+50^{\circ}\text{C}$  centigrade.
- b). According to FCC Part 2 Section 2.1055(d)(2), for battery powered equipment, the frequency stability shall be measured with reducing primary supply voltage to the battery operating end point, which is specified by the manufacturer.
- c). According to FCC Part 90 Section 90.213, the frequency tolerance must be maintained within 0.00025% for 12.5KHz channel separation and 0.0005% for 25KHz channel separation.

### 6.2 MEASUREMENT PROCEDURE

#### 6.2.1 Frequency stability versus environmental temperature

1. Setup the configuration per figure 1 for frequencies measurement inside an environment chamber, Install new battery in the EUT.
2. Turn on EUT and set SA center frequency to the EUT radiated frequency. Set SA Resolution Bandwidth to 1KHz and Video Resolution Bandwidth to 1KHz and Frequency Span to 50KHz. Record this frequency as reference frequency.
3. Set the temperature of chamber to  $50^{\circ}\text{C}$ . Allow sufficient time (approximately 30 min) for the temperature of the chamber to stabilize. While maintaining a constant temperature inside the chamber, turn the EUT on and measure the EUT operating frequency.
4. Repeat step 2 with a  $10^{\circ}\text{C}$  decreased per stage until the lowest temperature  $-30^{\circ}\text{C}$  is measured, record all measured frequencies on each temperature step.

#### 6.2.2 Frequency stability versus input voltage

1. Setup the configuration per figure 1 for frequencies measured at temperature if it is within  $15^{\circ}\text{C}$  to  $25^{\circ}\text{C}$ . Otherwise, an environment chamber set for a temperature of  $20^{\circ}\text{C}$  shall be used. The EUT shall be powered by DC 7.4V
2. Set SA center frequency to the EUT radiated frequency. Set SA Resolution Bandwidth to 1 KHz and Video Resolution Bandwidth to 1KHz. Record this frequency as reference frequency.
3. Supply the EUT primary voltage at the operating end point which is specified by manufacturer and record the frequency.

### 6.3 TEST SETUP BLOCK DIAGRAM

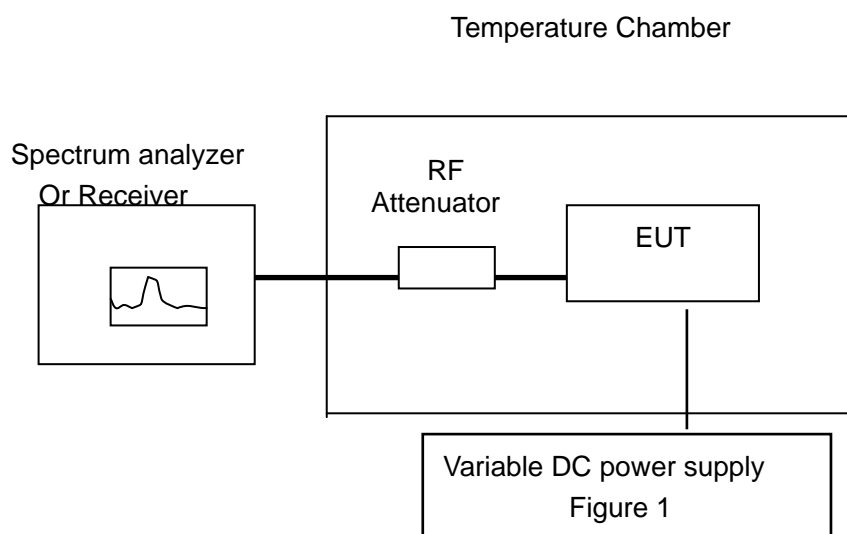

### 6.4 TEST EQUIPMENT USED:

NAME OF EQUIPMENT	MANUFACTURER	MODEL	SERIAL NUMBER	CAL. DATE
Receiver	R&S	ESIB26	A0304218	2010.06
Climate Chamber	Albatross	--	--	2010.12

### 6.5 TEST RESULT

(1) Frequency stability versus input voltage (Supply nominal voltage is 7.4V)

**Bottom Channel @ 12.5 KHz Channel Separation**

Reference Frequency:	406.2 MHz	Limit:	2.5ppm
Environment Temperature	Power Supply	Frequency Deviation	
(°C)	(V)	(MHz)	ppm
50	7.4	406.200358	0.881
40	7.4	406.200296	0.729
30	7.4	406.200257	0.633
20	7.4	406.200241	0.593
10	7.4	406.200197	0.485
0	7.4	406.200165	0.406
-10	7.4	406.200158	0.389
-20	7.4	406.200124	0.305
-30	7.4	406.200099	0.244

**Middle Channel @ 12.5 KHz Channel Separation**

Reference Frequency:	450.1 MHz	Limit:	2.5ppm
Environment Temperature	Power Supply	Frequency Deviation	
(°C)	(V)	(MHz)	ppm
50	7.4	450.100379	0.842
40	7.4	450.100335	0.744
30	7.4	450.100289	0.642
20	7.4	450.100278	0.618
10	7.4	450.100187	0.415
0	7.4	450.100177	0.393
-10	7.4	450.100161	0.358
-20	7.4	450.100151	0.335
-30	7.4	450.100099	0.220

**Top Channel @ 12.5KHz Channel Separation**

Reference Frequency:	469.965 MHz	Limit:	2.5ppm
Environment Temperature	Power Supply	Frequency Deviation	
(°C)	(V)	(MHz)	ppm
50	7.4	469.965361	0.768
40	7.4	469.965335	0.713
30	7.4	469.965281	0.598
20	7.4	469.965225	0.479
10	7.4	469.965178	0.379
0	7.4	469.965163	0.347
-10	7.4	469.965151	0.321
-20	7.4	469.965141	0.300
-30	7.4	469.965088	0.187



**Bottom Channel @ 25.0 KHz Channel Separation**

Reference Frequency:	406.2 MHz	Limit:	5.0ppm
Environment Temperature	Power Supply	Frequency Deviation	
(°C)	(V)	(MHz)	ppm
50	7.4	406.200421	1.036
40	7.4	406.200367	0.903
30	7.4	406.200299	0.736
20	7.4	406.200287	0.707
10	7.4	406.200238	0.586
0	7.4	406.200221	0.544
-10	7.4	406.200201	0.495
-20	7.4	406.200187	0.460
-30	7.4	406.200111	0.273

**Middle Channel @ 25.0 KHz Channel Separation**

Reference Frequency:	450.1 MHz	Limit:	5.0ppm
Environment Temperature	Power Supply	Frequency Deviation	
(°C)	(V)	(MHz)	ppm
50	7.4	450.100433	0.962
40	7.4	450.100401	0.891
30	7.4	450.100388	0.862
20	7.4	450.100299	0.664
10	7.4	450.100253	0.562
0	7.4	450.100221	0.491
-10	7.4	450.100197	0.438
-20	7.4	450.100164	0.364
-30	7.4	450.100113	0.251

**Top Channel @ 25.0 KHz Channel Separation**

Reference Frequency:	469.965 MHz	Limit:	5.0ppm
Environment Temperature	Power Supply	Frequency Deviation	
(°C)	(V)	(MHz)	ppm
50	7.4	469.965461	0.981
40	7.4	469.965431	0.917
30	7.4	469.965381	0.811
20	7.4	469.965321	0.683
10	7.4	469.965307	0.653
0	7.4	469.965263	0.560
-10	7.4	469.965191	0.406
-20	7.4	469.965155	0.330
-30	7.4	469.965097	0.206

(2) Frequency stability versus input voltage (Battery End Point voltage is 6.4V)

**Bottom Channel @ 12.5 KHz Channel Separation**

Reference Frequency:	406.2 MHz	Limit:	2.5ppm
Environment Temperature	Power Supply	Frequency Deviation	
(°C)	(V)	(MHz)	ppm
50	6.4	406.200362	0.891
40	6.4	406.200294	0.724
30	6.4	406.200253	0.623
20	6.4	406.200244	0.601
10	6.4	406.200194	0.478
0	6.4	406.200161	0.396
-10	6.4	406.200152	0.374
-20	6.4	406.200121	0.298
-30	6.4	406.200101	0.249

**Middle Channel @ 12.5 KHz Channel Separation**

Reference Frequency:	450.1 MHz	Limit:	2.5ppm
Environment Temperature	Power Supply	Frequency Deviation	
(°C)	(V)	(MHz)	ppm
50	6.4	450.100373	0.829
40	6.4	450.100331	0.735
30	6.4	450.100282	0.627
20	6.4	450.100271	0.602
10	6.4	450.100183	0.407
0	6.4	450.100175	0.389
-10	6.4	450.100155	0.344
-20	6.4	450.100143	0.318
-30	6.4	450.100092	0.204

**Top Channel @ 12.5KHz Channel Separation**

Reference Frequency:	469.965 MHz	Limit:	2.5ppm
Environment Temperature	Power Supply	Frequency Deviation	
(°C)	(V)	(MHz)	ppm
50	6.4	469.965369	0.785
40	6.4	469.965338	0.719
30	6.4	469.965283	0.602
20	6.4	469.965221	0.470
10	6.4	469.965173	0.368
0	6.4	469.965161	0.343
-10	6.4	469.965153	0.326
-20	6.4	469.965145	0.309
-30	6.4	469.965081	0.172

**Bottom Channel @ 25.0 KHz Channel Separation**

Reference Frequency:	406.2 MHz	Limit:	5.0ppm
Environment Temperature	Power Supply	Frequency Deviation	
(°C)	(V)	(MHz)	ppm
50	6.4	406.200421	1.036
40	6.4	406.200367	0.903
30	6.4	406.200299	0.736
20	6.4	406.200287	0.707
10	6.4	406.200238	0.586
0	6.4	406.200221	0.544
-10	6.4	406.200201	0.495
-20	6.4	406.200187	0.460
-30	6.4	406.200111	0.273

**Middle Channel @ 25.0 KHz Channel Separation**

Reference Frequency:	450.1 MHz	Limit:	5.0ppm
Environment Temperature	Power Supply	Frequency Deviation	
(°C)	(V)	(MHz)	ppm
50	6.4	450.100433	0.962
40	6.4	450.100401	0.891
30	6.4	450.100388	0.862
20	6.4	450.100299	0.664
10	6.4	450.100253	0.562
0	6.4	450.100221	0.491
-10	6.4	450.100197	0.438
-20	6.4	450.100164	0.364
-30	6.4	450.100113	0.251

**Top Channel @ 25.0 KHz Channel Separation**

Reference Frequency:	469.965 MHz	Limit:	5.0ppm
Environment Temperature	Power Supply	Frequency Deviation	
(°C)	(V)	(MHz)	ppm
50	6.4	469.965461	0.981
40	6.4	469.965431	0.917
30	6.4	469.965381	0.811
20	6.4	469.965321	0.683
10	6.4	469.965307	0.653
0	6.4	469.965263	0.560
-10	6.4	469.965191	0.406
-20	6.4	469.965155	0.330
-30	6.4	469.965097	0.206

(3) Frequency stability versus input voltage (Battery Fully Charged voltage is 8.51V)

**Bottom Channel @ 12.5 KHz Channel Separation**

Reference Frequency:	406.2 MHz	Limit:	2.5ppm
Environment Temperature	Power Supply	Frequency Deviation	
(°C)	(V)	(MHz)	ppm
50	8.51	406.200369	0.908
40	8.51	406.200291	0.716
30	8.51	406.200251	0.618
20	8.51	406.200241	0.593
10	8.51	406.200191	0.470
0	8.51	406.200158	0.389
-10	8.51	406.200151	0.372
-20	8.51	406.200114	0.281
-30	8.51	406.200097	0.239

**Middle Channel @ 12.5 KHz Channel Separation**

Reference Frequency:	450.1 MHz	Limit:	2.5ppm
Environment Temperature	Power Supply	Frequency Deviation	
(°C)	(V)	(MHz)	ppm
50	8.51	450.100379	0.842
40	8.51	450.100335	0.744
30	8.51	450.100281	0.624
20	8.51	450.100267	0.593
10	8.51	450.100181	0.402
0	8.51	450.100161	0.358
-10	8.51	450.100141	0.313
-20	8.51	450.100131	0.291
-30	8.51	450.100101	0.224

**Top Channel @ 12.5KHz Channel Separation**

Reference Frequency:	469.965 MHz	Limit:	2.5ppm
Environment Temperature	Power Supply	Frequency Deviation	
(°C)	(V)	(MHz)	ppm
50	8.51	469.965361	0.768
40	8.51	469.965332	0.706
30	8.51	469.965285	0.606
20	8.51	469.965223	0.475
10	8.51	469.965171	0.364
0	8.51	469.965165	0.351
-10	8.51	469.965158	0.336
-20	8.51	469.965149	0.317
-30	8.51	469.965085	0.181

**Bottom Channel @ 25.0 KHz Channel Separation**

Reference Frequency:	406.2 MHz	Limit:	5.0ppm
Environment Temperature	Power Supply	Frequency Deviation	
(°C)	(V)	(MHz)	ppm
50	8.51	406.200428	1.054
40	8.51	406.200369	0.908
30	8.51	406.200291	0.716
20	8.51	406.200285	0.702
10	8.51	406.200235	0.579
0	8.51	406.200221	0.544
-10	8.51	406.200201	0.495
-20	8.51	406.200183	0.451
-30	8.51	406.200101	0.249

**Middle Channel @ 25.0 KHz Channel Separation**

Reference Frequency:	450.1 MHz	Limit:	5.0ppm
Environment Temperature	Power Supply	Frequency Deviation	
(°C)	(V)	(MHz)	ppm
50	8.51	450.100439	0.975
40	8.51	450.100389	0.864
30	8.51	450.100381	0.846
20	8.51	450.100301	0.669
10	8.51	450.100251	0.558
0	8.51	450.100219	0.487
-10	8.51	450.100195	0.433
-20	8.51	450.100161	0.358
-30	8.51	450.100111	0.247

**Top Channel @ 25.0 KHz Channel Separation**

Reference Frequency:	469.965 MHz	Limit:	5.0ppm
Environment Temperature	Power Supply	Frequency Deviation	
(°C)	(V)	(MHz)	ppm
50	8.51	469.965468	0.996
40	8.51	469.965439	0.934
30	8.51	469.965379	0.806
20	8.51	469.965318	0.677
10	8.51	469.965301	0.640
0	8.51	469.965265	0.564
-10	8.51	469.965241	0.513
-20	8.51	469.965152	0.323
-30	8.51	469.965091	0.194

## 7. EMISSION BANDWIDTH

### 7.1 PROVISIONS APPLICABLE

According to FCC Part 90 Section 90.209: The authorized bandwidth shall be 11.25 KHz for 12.5 KHz and 20 KHz for 25 KHz

### 7.2 MEASUREMENT PROCEDURE

- 1). The EUT was placed on a turntable which is 0.8m above ground plane.
- 2). The EUT was modulated by 2.5 KHz Sine wave audio signal, The level of the audio signal employed is 16 dB greater than that necessary to produce 50% of rated system deviation. Rated system deviation is 2.5 kHz (12.5 kHz channel spacing) and 5 kHz (25 kHz channel spacing).
- 3). Set SPA Center Frequency = fundamental frequency, RBW=VBW= 300 Hz, Span =50 KHz.
- 4). Set SPA Max hold. Mark peak, -26 dB.

### 7.3 TEST SETUP BLOCK DIAGRAM

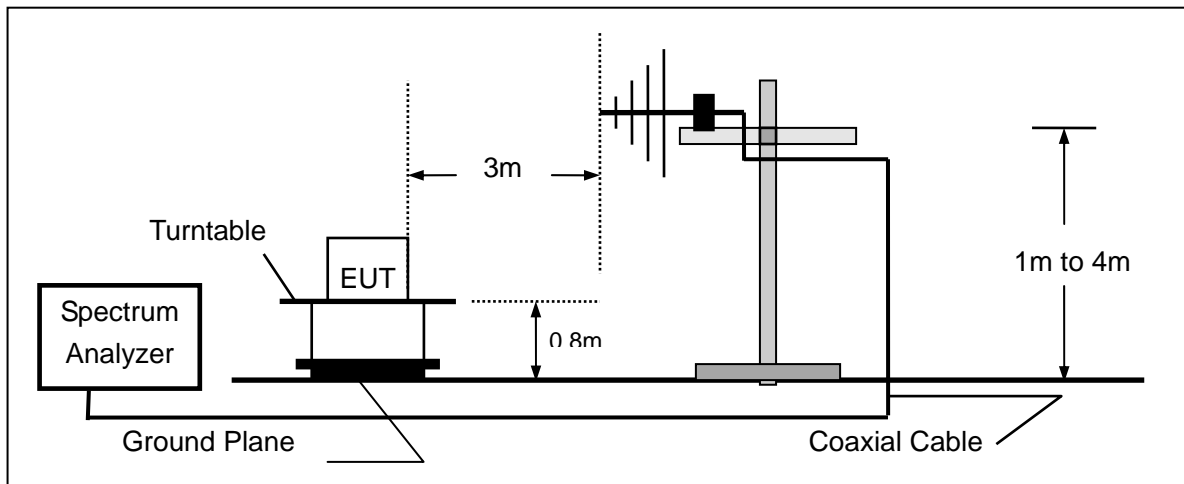

### 7.4 MEASUREMENT EQUIPMENT USED:

NAME OF EQUIPMENT	MANUFACTURER	MODEL	SERIAL NUMBER	CAL. DATE
SPECTRUM ANALYZER	AGILENT	E4440A	US44300399	2010.06
MODULATION ANALYZER	HP	8901B	3104A03367	2010.06
BROADBAND ANT.	R&S	HL562	A0304224	2010.06

**7.5 MEASUREMENT RESULT:**

<b>26 dB Bandwidth Measurement Result</b>						
Operating Frequency	12.5 KHz Channel Separation			25 KHz Channel Separation		
	Test Data	Limits	Result	Test Data	Limits	Result
406.2MHz	10.27 KHz	11.25 KHz	Pass	15.31KHz	20.00 KHz	Pass
450.1MHz	10.42KHz	11.25 KHz	Pass	15.43 KHz	20.00 KHz	Pass
460.965MHz	10.25 KHz	11.25 KHz	Pass	15.21 KHz	20.00 KHz	Pass

**Occupied bandwidth of Middle Channel (Maximum) @ 12.5KHz Channel Separation**

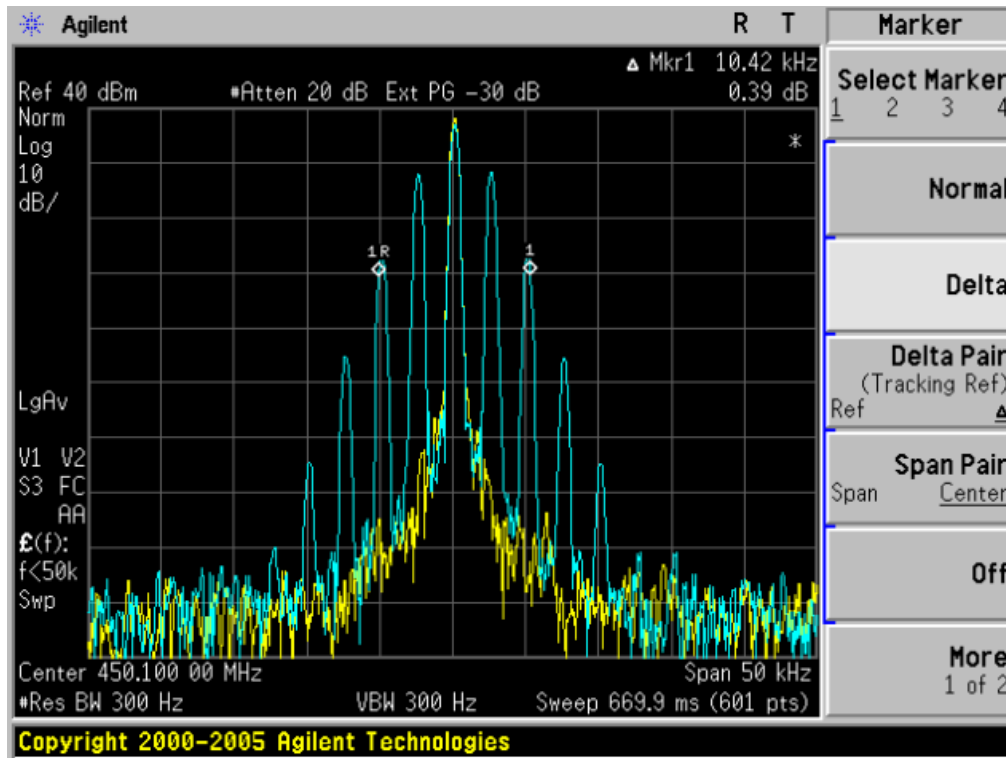

**Occupied bandwidth of Middle Channel (Maximum) @ 25KHz Channel Separation**

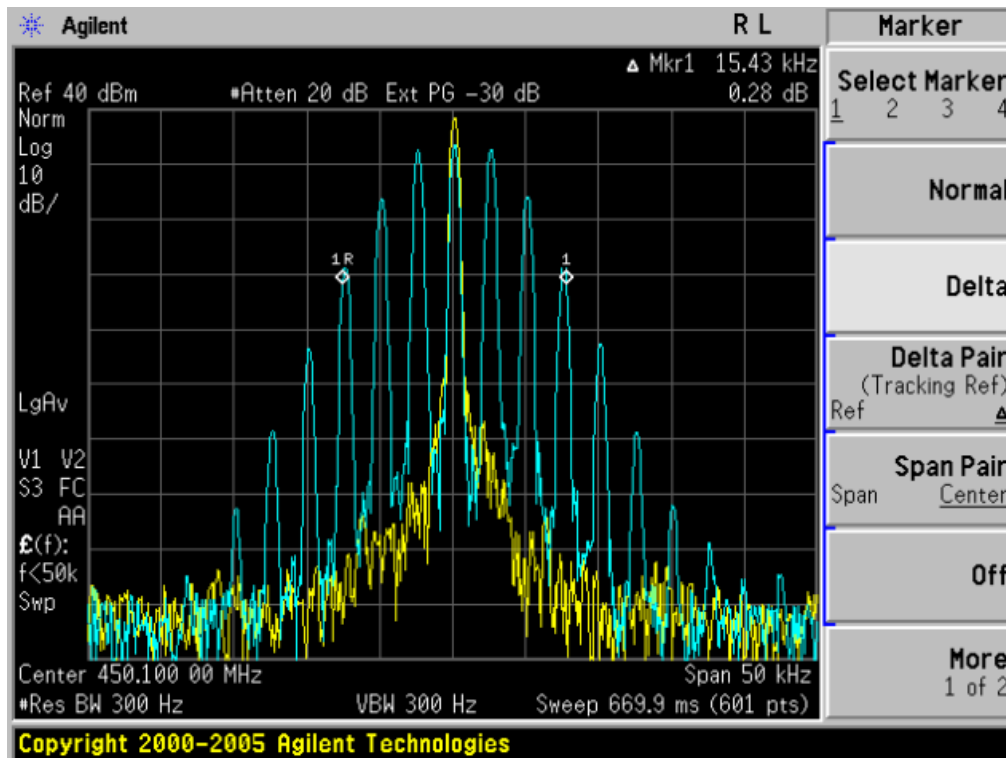



## 8. UNWANTED RADIATION

### 8.1 PROVISIONS APPLICABLE

8.1.1 According to Section 90.210, the power of each unwanted emission shall be less than Transmitted Power as specified below for transmitters designed to operate with 12.5 KHz channel bandwidth:

- (1). On any frequency removed from the center of the authorized bandwidth  $f_0$  to 5.625 KHz removed from  $f_0$ : Zero dB
- (2). On any frequency removed from the center of the authorized bandwidth by a displacement frequency ( $f_d$  in KHz)  $f_0$  of more than 5.625 KHz but no more than 12.5 KHz: At least  $7.27(f_d - 2.88 \text{ KHz})$  dB
- (3). On any frequency removed from the center of the authorized bandwidth by a displacement Frequency ( $f_d$  in KHz)  $f_0$  of more than 12.5 KHz: At least  $50 + 10 \log(P)$  dB or 70 dB, whichever is lesser attenuation.

8.1.2 According to Section 90.210, Emission mask B. For transmitters designed to transmit with 25 KHz channel separation and equipped with an audio low-pass filter, the power of any emission must be attenuated below the unmodulated carrier power (P) as following:

- (1), On any frequency removed from the assigned frequency by more than 50 percent, but no more than 100 percent of the authorized bandwidth: At least 25 dB.
- (2), On any frequency removed from the assigned frequency by more than 100 percent, but no more than 250 percent of the authorized bandwidth: At least 35 dB.
- (3), On any frequency removed from the assigned frequency by more than 250 percent of the authorized bandwidth: At least  $43 + 10 \log(P)$  dB.

### 8.2 MEASUREMENT PROCEDURE

- (1) On a test site, the EUT shall be placed on a turntable, and in the position closest to the normal use as declared by the user.
- (2) The test antenna shall be oriented initially for vertical polarization located 3m from the EUT to correspond to the transmitter.
- (3) The output of the antenna shall be connected to the measuring receiver and either a peak or quasi-peak detector was used for the measurement as indicated on the report. The detector selection is based on how close the emission level was approaching the limit.
- (4) The transmitter shall be switched on; if possible, without the modulation and the measurement receiver shall be tuned to the frequency of the transmitter under test.
- (5) The test antenna shall be raised and lowered through the specified range of height until the measuring receiver detects a maximum signal level.
- (6) The transmitter shall then be rotated through 360° in the horizontal plane, until the maximum signal level is detected by the measuring receiver.
- (7) The test antenna shall be raised and lowered again through the specified range of height until the measuring receiver detects a maximum signal level.

- (8) The maximum signal level detected by the measuring receiver shall be noted.
- (9) The measurement shall be repeated with the test antenna set to horizontal polarization.
- (10) Replace the antenna with a proper Antenna (substitution antenna).
- (11) The substitution antenna shall be oriented for vertical polarization and, if necessary, the length of the substitution antenna shall be adjusted to correspond to the frequency of transmitting.
- (12) The substitution antenna shall be connected to a calibrated signal generator.
- (13) If necessary, the input attenuator setting of the measuring receiver shall be adjusted in order to increase the sensitivity of the measuring receiver.
- (14) The test antenna shall be raised and lowered through the specified range of the height to ensure that the maximum signal is received.
- (15) The input signal to substitution antenna shall be adjusted to the level that produces a level detected by the measuring receiver, that is equal to the level noted while the transmitter radiated power was measured, corrected for the change of input attenuation setting of the measuring receiver.
- (16) The input level to the substitution antenna shall be recorded as power level in dBm, corrected for any change of input attenuator setting of the measuring receiver.
- (17) The measurement shall be repeated with the test antenna and the substitution antenna oriented for horizontal polarization.

### 8.3 TEST SETUP BLOCK DIAGRAM

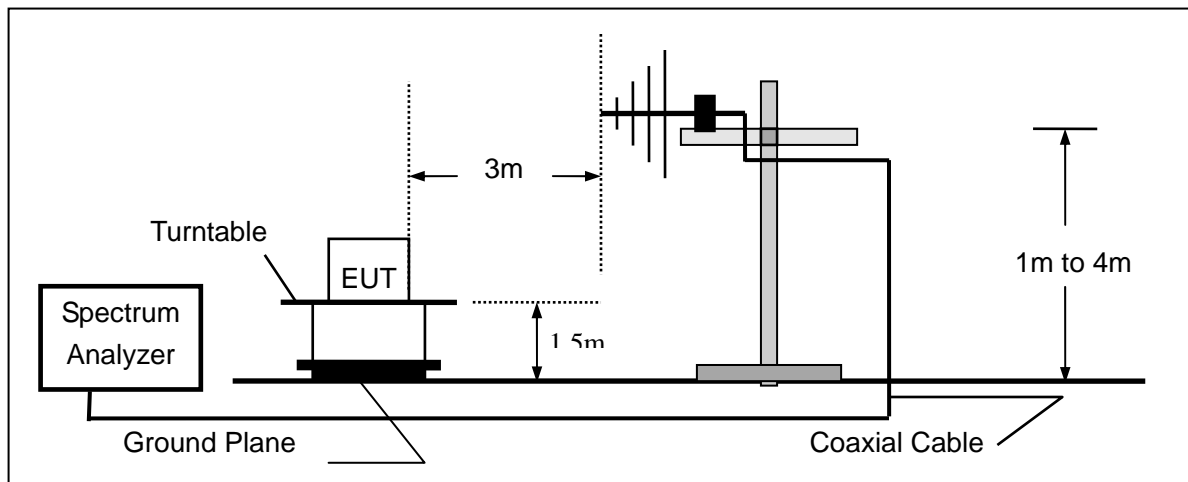

### SUBSTITUTION METHOD: (Radiated Emissions)

#### Radiated Below 1GHz

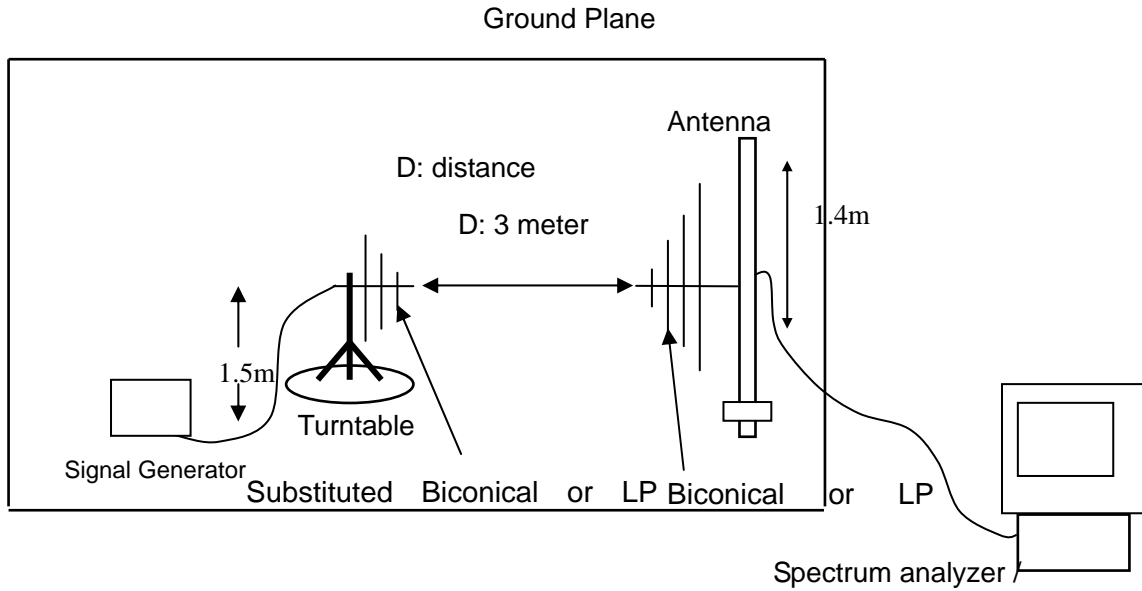

#### Radiated Above 1 GHz

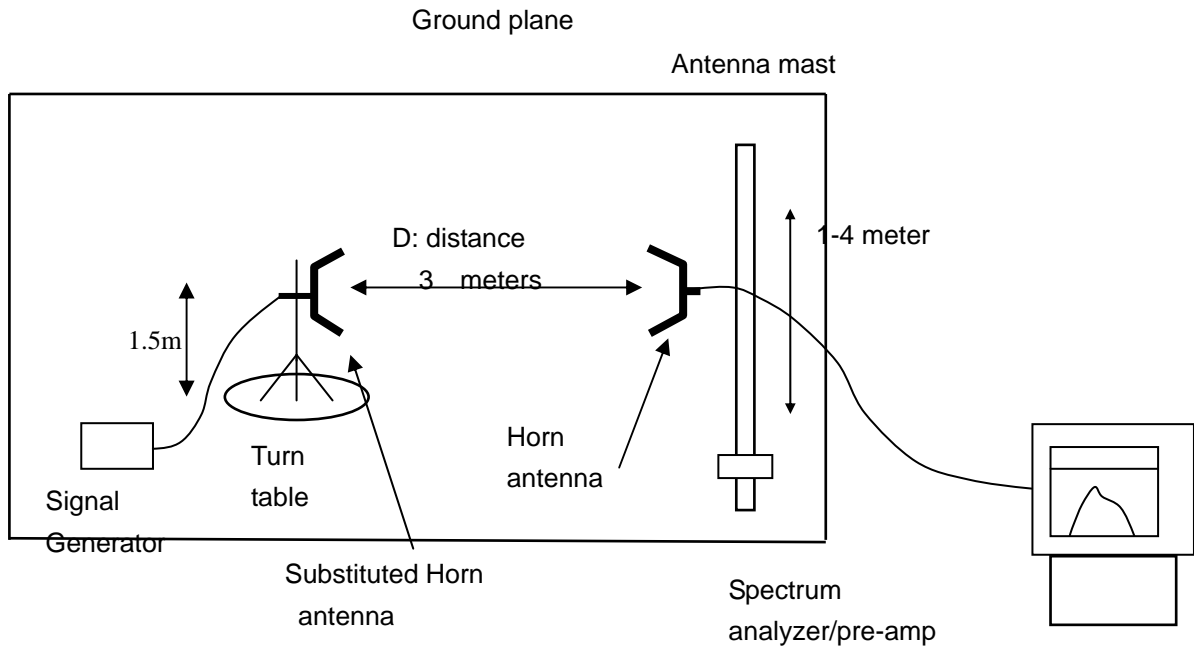

#### 8.4 MEASUREMENT EQUIPMENT USED:

NAME OF EQUIPMENT	MANUFACTURER	MODEL	SERIAL NUMBER	CAL. DATE
SPECTRUM ANALYZER	AGILENT	E4440A	US44300399	2010.06
TEST RECEIVER	R&S	ESIB26	A0304218	2010.06
LOOP ANTENNA	R&S	HFH2-Z2	A0304220	2010.06
HORN ANT.	R&S	HF906	100150	2010.06
BROADBAND ANT.	R&S	HL562	A0304224	2010.06

#### 8.5 MEASUREMENT RESULTS:

##### Measurement Result for 12.5 KHz Channel Separation-4W

On any frequency removed from the center of the authorized bandwidth by a displacement Frequency ( $f_d$  in KHz)  $f_o$  of more than 12.5 KHz: At least  $50+10 \log(P)$  dB or 70 dB, which ever is lesser attenuation.

**Limit: At least  $50+10 \log(P) = 50+10\log(4)=56$**

##### Measurement Result For 25 KHz Channel Separation-4W

On any frequency removed from the assigned frequency by more than 250 percent of the authorized bandwidth: At least  $43+10\log(P)$  dB.

**Limit: At least  $43+10 \log(P) = 43+10\log(4)=49$**

**Measurement Result for 25 KHz Channel Separation @ 406.2MHz**

Emission Frequency (MHz)	Ant. Polarity(H/V)	Measurement Result Below carrier(dBc)	Limit	Result(P/F)
406.200	v	0		pass
812.400	v	75.33(-39.33dBm)	56	pass
1218.600	v	76.65	56	pass
1624.800	v	76.22	56	pass
2031.000	v	85.76	56	pass
2437.200	v	92.58	56	pass
2843.400	v	94.67	56	pass
3249.600	v	95.53	56	pass
3655.800	v	96.09	56	pass
4062.000	v	96.22	56	pass

**Measurement Result for 25 KHz Channel Separation @ 450.1MHz**

Emission Frequency (MHz)	Ant. Polarity(H/V)	Measurement Result Below carrier(dBc)	Limit	Result(P/F)
450.100	v	0		pass
900.200	v	75.55(-39.55dBm)	56	pass
1350.300	v	81.11	56	pass
1800.400	v	84.21	56	pass
2250.500	v	87.43	56	pass
2700.600	v	91.76	56	pass
3150.700	v	93.77	56	pass
3600.800	v	94.44	56	pass
4050.900	v	91.56	56	pass
4501.000	v	97.22	56	pass

**Measurement Result for 25 KHz Channel Separation @ 469.95MHz**

Emission Frequency (MHz)	Ant. Polarity(H/V)	Measurement Result Below carrier(dBc)	Limit	Result(P/F)
469.950	v	0		pass
939.900	v	77.43(-41.43dBm)	56	pass
1409.850	v	78.67	56	pass
1879.800	v	79.77	56	pass
2349.750	v	84.67	56	pass
2819.700	v	91.67	56	pass
3289.650	v	92.32	56	pass
3759.600	v	93.78	56	pass
4229.550	v	94.45	56	pass
4699.500	v	92.76	56	pass

**Measurement Result for 12.5 KHz Channel Separation @ 406.2MHz**

Emission Frequency (MHz)	Ant. Polarity(H/V)	Measurement Result Below carrier(dBc)	Limit	Result(P/F)
406.200	v	0		pass
812.400	v	70.31(-34.31dBm)	49	pass
1218.60	v	75.41(-39.41dBm)	49	pass
1624.800	v	78.21	49	pass
2031.000	v	85.32	49	pass
2437.200	v	82.56	49	pass
2843.400	v	90.55	49	pass
3249.600	v	92.34	49	pass
3655.800	v	91.25	49	pass
4062.000	v	92.65	49	pass

**Measurement Result for 12.5 KHz Channel Separation @ 450.1MHz**

Emission Frequency (MHz)	Ant. Polarity(H/V)	Measurement Result Below carrier(dBc)	Limit	Result(P/F)
450.100	v	0		pass
900.200	v	73.44(-36.44dBm)	49	pass
1350.300	v	76.21	49	pass
1800.400	v	80.13	49	pass
2250.500	v	83.42	49	pass
2700.600	v	89.68	49	pass
3150.700	v	91.16	49	pass
3600.800	v	92.56	49	pass
4050.900	v	93.67	49	pass
4501.000	v	95.33	49	pass

**Measurement Result for 12.5 KHz Channel Separation @ 469.95MHz**

Emission Frequency (MHz)	Ant. Polarity(H/V)	Measurement Result Below carrier(dBc)	Limit	Result(P/F)
469.950	v	0		pass
939.900	v	74.21(-38.21dBm)	49	pass
1409.850	v	83.34	49	pass
1879.800	v	85.64	49	pass
2349.750	v	87.52	49	pass
2819.700	v	92.46	49	pass
3289.650	v	93.26	49	pass
3759.600	v	95.76	49	pass
4229.550	v	95.21	49	pass
4699.500	v	93.77	49	pass

**Notes: The emissions were scanned from 30 MHz to 10th harmonics; The worst case for Transmitter spurious is 36dBm-70.31dBc=-34.31dBm**

### 8.6 EMISSION MASK PLOT

The detailed procedure employed for Emission Mask measurements are specified as following:

- The transmitter shall be modulated by a 2.5 kHz audio signal,
- The level of the audio signal employed is 16 dB greater than that necessary to produce 50% of rated system deviation. Rated system deviation is 2.5 kHz (12.5 kHz channel spacing) and 5 kHz (25 kHz channel spacing)

#### The Worst Emission Mask for 12.5 KHz channel Separation (4W)

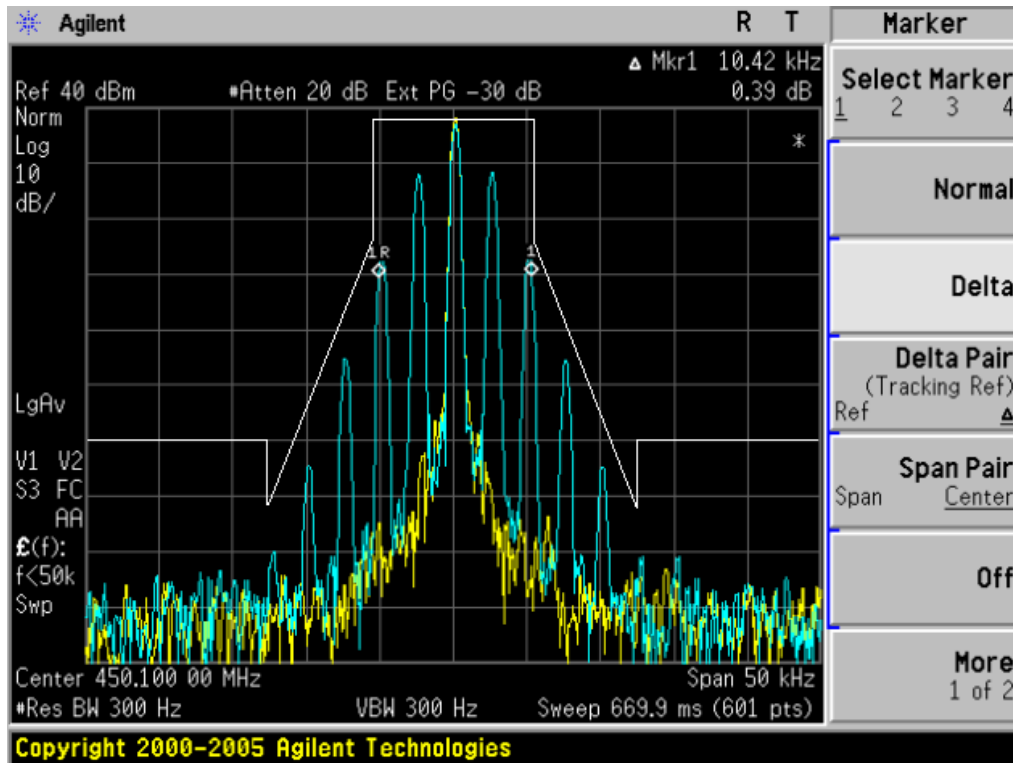

**The Worst Emission Mask for 25 KHz channel Separation (4W)**

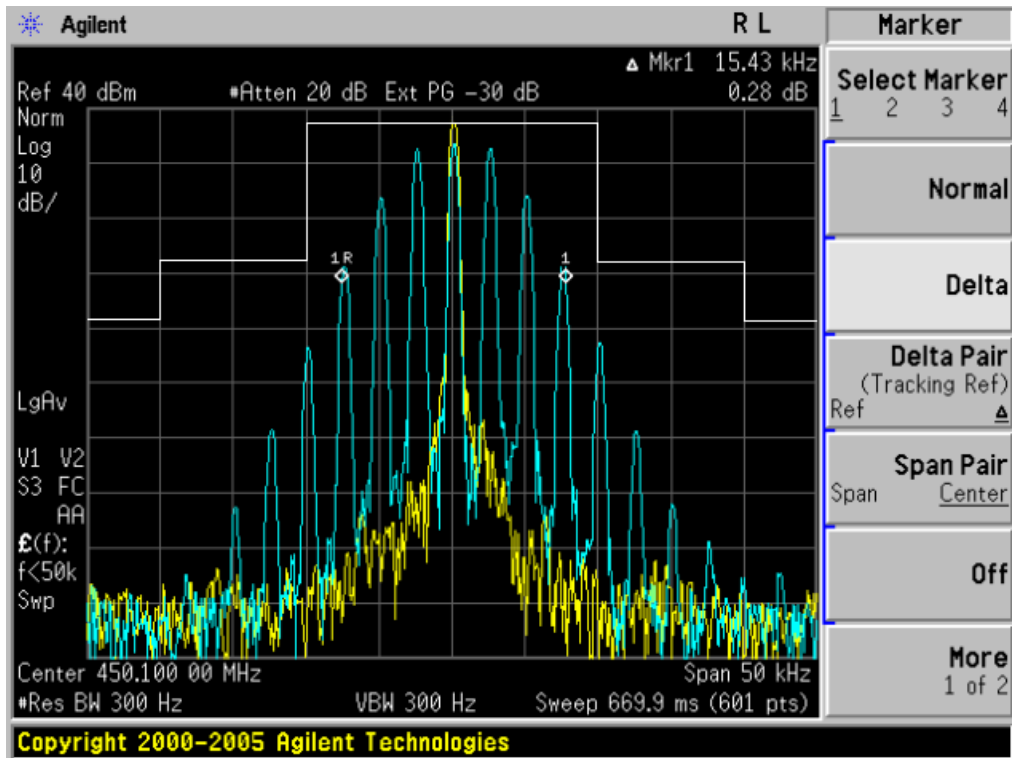



## 9. MODULATION CHARACTERISTICS

### 9.1 PROVISIONS APPLICABLE

According to CFR 47 section 2.1047(a), for Voice Modulation Communication Equipment, the frequency response of the audio modulation circuit over a range of 100 to 5000Hz shall be measured.

### 9.2 MEASUREMENT METHOD

#### 9.2.1 Modulation Limit

- (1). Configure the EUT as shown in figure 1, adjust the audio input for 60% of rated system deviation at 1KHz using this level as a reference (0dB) and vary the input level from -20 to +20dB. Record the frequency deviation obtained as a function of the input level.
- (2). Repeat step 1 with input frequency changing to 300, 1000, 1500 and 3000Hz in sequence.

#### 9.2.2 Audio Frequency Response

- (1). Configure the EUT as shown in figure 1.
- (2). Adjust the audio input for 20% of rated system deviation at 1 KHz using this level as a reference (0 dB).
- (3). Vary the Audio frequency from 100 Hz to 10 KHz and record the frequency deviation.
- (4). Audio Frequency Response =  $20\log_{10} (\text{Deviation of test frequency}/\text{Deviation of 1 KHz reference})$ .

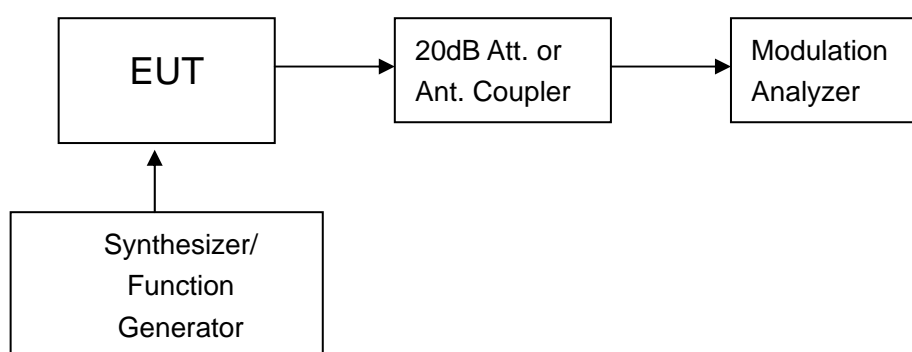

**Figure 1: Modulation characteristic measurement configuration**

### 9.3 MEASUREMENT INSTRUMENTS

NAME OF EQUIPMENT	MANUFACTURER	MODEL	SERIAL NUMBER	CAL. DATE
Modulation Analyzer	HP	8901B	3104A03367	2010.06

**9.4 MEASUREMENT RESULT**

**(a). Modulation Limit:**

**Middle Channel @ 12.5 KHz Channel Separations**

Modulation Level (dB)	Peak Freq. Deviation At 300 Hz	Peak Freq. Deviation At 1000 Hz	Peak Freq. Deviation At 1500 Hz	Peak Freq. Deviation At 3000 Hz
-20	0.04	0.41	0.46	0.61
-15	0.08	0.79	0.92	1.21
-10	0.17	0.97	1.36	1.41
-5	0.26	1.25	1.68	1.72
0	0.41	1.58	1.95	1.89
+5	0.35	1.91	1.87	1.74
+10	0.31	1.88	1.81	1.82
+15	0.36	1.69	1.69	1.61
+20	0.53	1.52	1.56	1.49

**Modulation Limit**

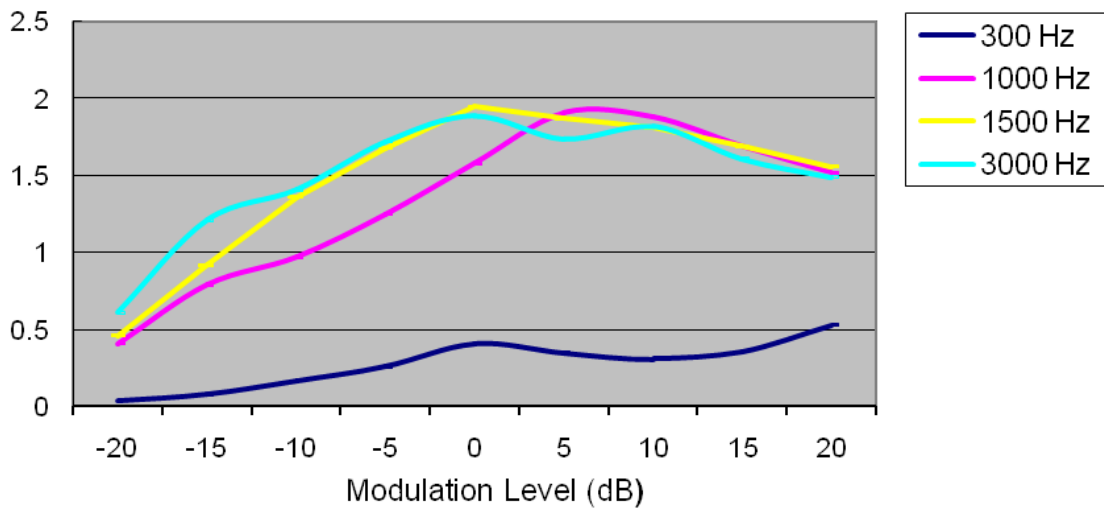

**Middle Channel @ 25KHz Channel Separation**

Modulation Level (dB)	Peak Freq. Deviation At 300 Hz	Peak Freq. Deviation At 1000 Hz	Peak Freq. Deviation At 1500 Hz	Peak Freq. Deviation At 3000 Hz
-20	0.06	0.41	0.48	0.64
-15	0.12	0.83	0.98	1.27
-10	0.22	1.62	1.82	2.12
-5	0.25	2.14	2.31	2.63
0	0.41	2.95	3.31	3.23
+5	0.52	3.31	3.52	3.29
+10	0.49	3.63	3.71	3.21
+15	0.57	3.32	3.34	3.03
+20	0.41	3.28	3.29	3.19

**Modulation Limit**

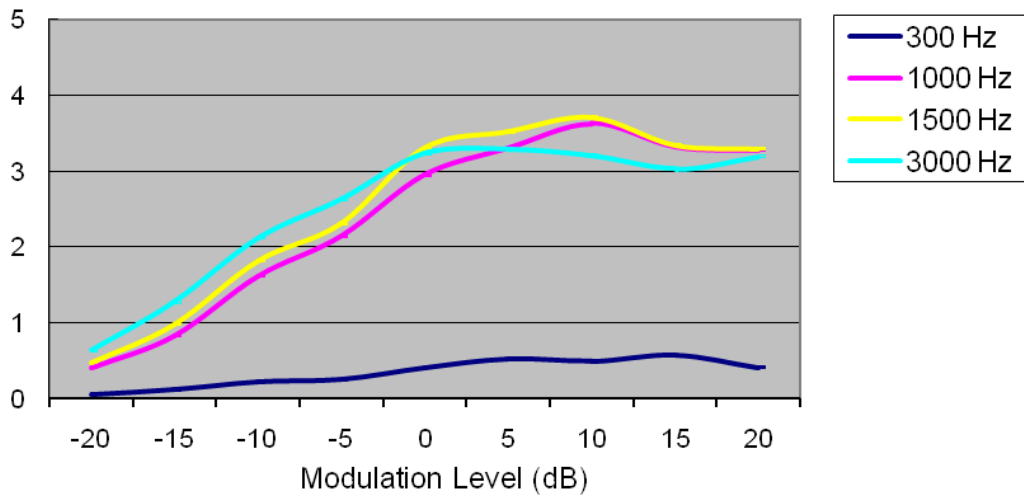

**(b). Audio Frequency Response:**

**12.5 KHz Channel Separations**

<b>Frequency (Hz)</b>	<b>Deviation (KHz)</b>
100	--
200	--
300	0.09
400	0.15
500	0.20
600	0.28
700	0.34
800	0.37
900	0.44
1000	0.51
1200	0.60
1400	0.74
1600	0.82
1800	0.93
2000	1.04
2400	1.26
2800	1.49
3000	1.53
3200	1.47
3600	1.12
4000	0.71
4500	0.42
5000	0.24
5500	0.13
6000	0.11
6500	0.06
7000	0.04
7500	0.03
9000	--
10000	--
12000	--
14000	--
18000	--
20000	--
30000	--

**Frequency Response of Middle Channel**

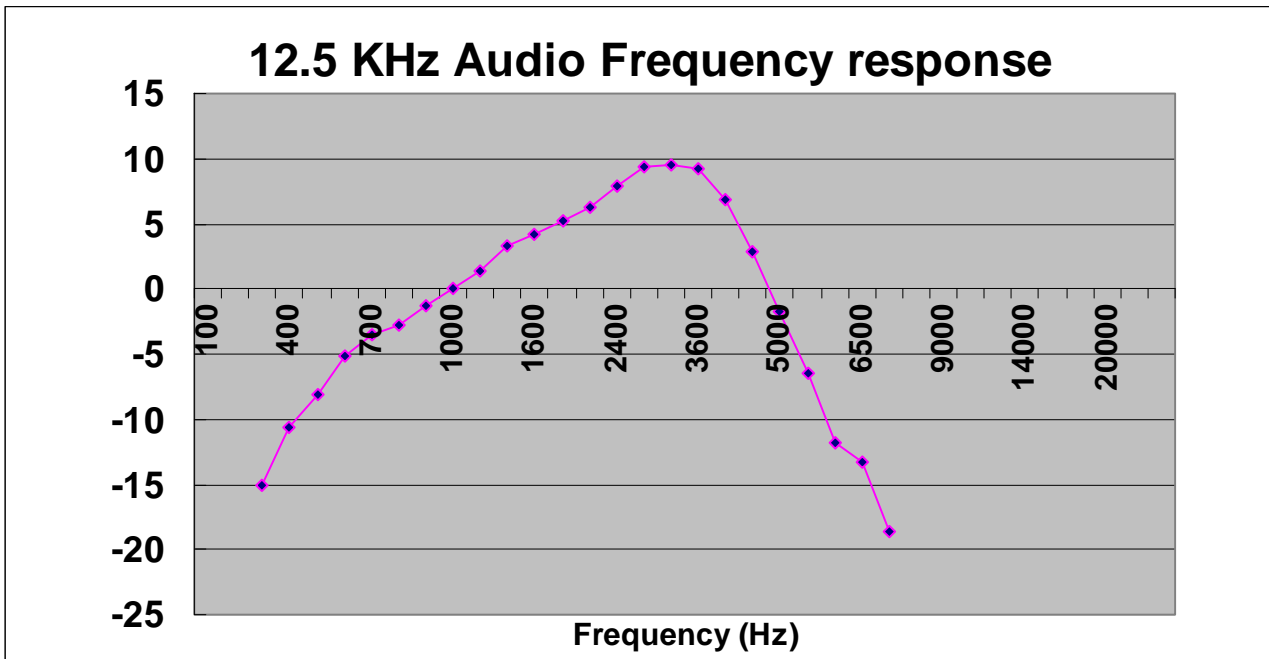

**25 KHz Channel Separation**

<b>Frequency (Hz)</b>	<b>Deviation (KHz)</b>
100	--
200	--
300	0.19
400	0.31
500	0.40
600	0.56
700	0.68
800	0.74
900	0.88
1000	1.02
1200	1.21
1400	1.48
1600	1.64
1800	1.86
2000	2.09
2400	2.53
2800	2.98
3000	3.07
3200	2.94
3600	2.25
4000	1.42
4500	0.84
5000	0.47
5500	0.26
6000	0.22
6500	0.13
7000	0.08
7500	0.06
9000	--
10000	--
12000	--
14000	--
16000	--
18000	--
20000	--
25000	--
30000	--

**Frequency Response of Middle Channel**

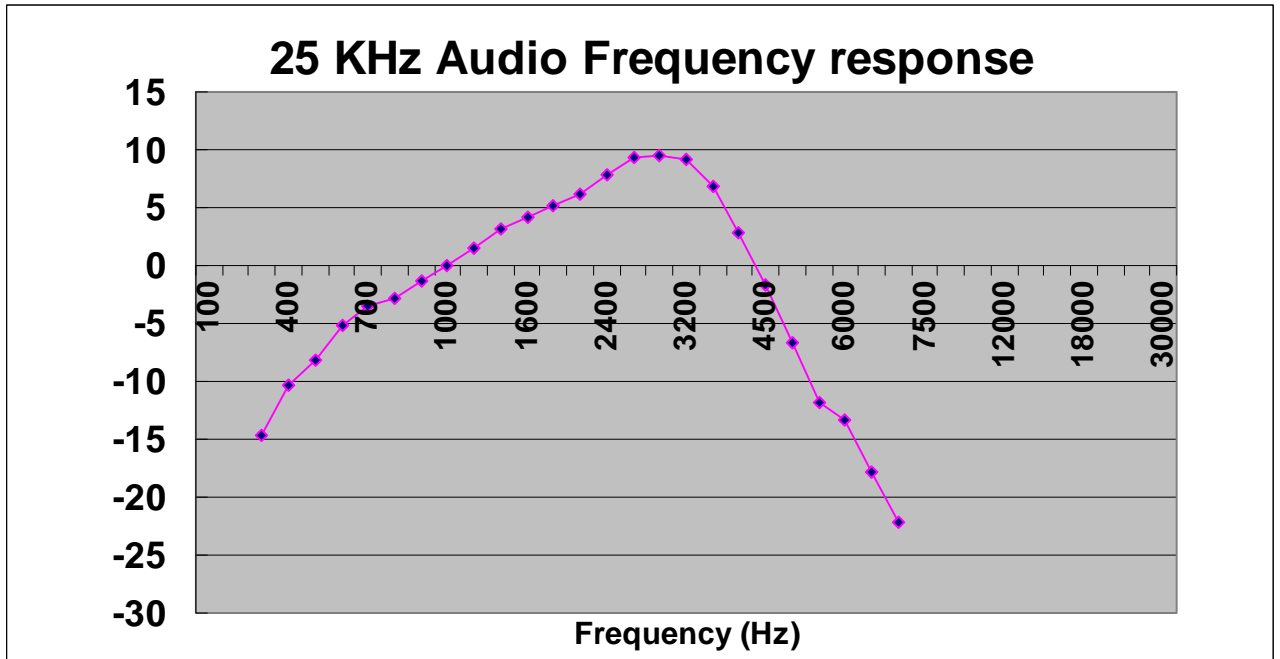

**10. MAXIMUM TRANSMITTER POWER (CONDUCTED OUTPUT POWER)**

**10.1 PROVISIONS APPLICABLE**

Per FCC §2.1046 and §90.205: Maximum ERP is dependent upon the station’s antenna HAAT and required service area.

RS-119 4.1 and §5.4: The output power shall be within ±1.0 dB of the manufacturer's rated power.

**10.2 TEST PROCEDURE**

The RF output of Two-way Radio was conducted to a spectrum analyzer through an appropriate attenuator.

The transmitter shall be modulated by a 2.5 kHz audio signal,

The level of the audio signal employed is 16 dB greater than that necessary to produce 50% of rated system deviation. Rated system deviation is 2.5 kHz (12.5 kHz channel spacing) and 5 kHz (25 kHz channel spacing)

Measure and record the transmitter output power, using a measurement (resolution) bandwidth at least two to three times the occupied bandwidth for transmitters equipped to capture the true peak emission of the equipment under test.

**10.3 TEST INSTRUMENTS**

NAME OF EQUIPMENT	MANUFACTURER	MODEL	SERIAL NUMBER	CAL. DATE
SPECTRUM ANALYZER	AGILENT	E4440A	US44300399	2010.06

**10.4 TEST CONFIGURATION**

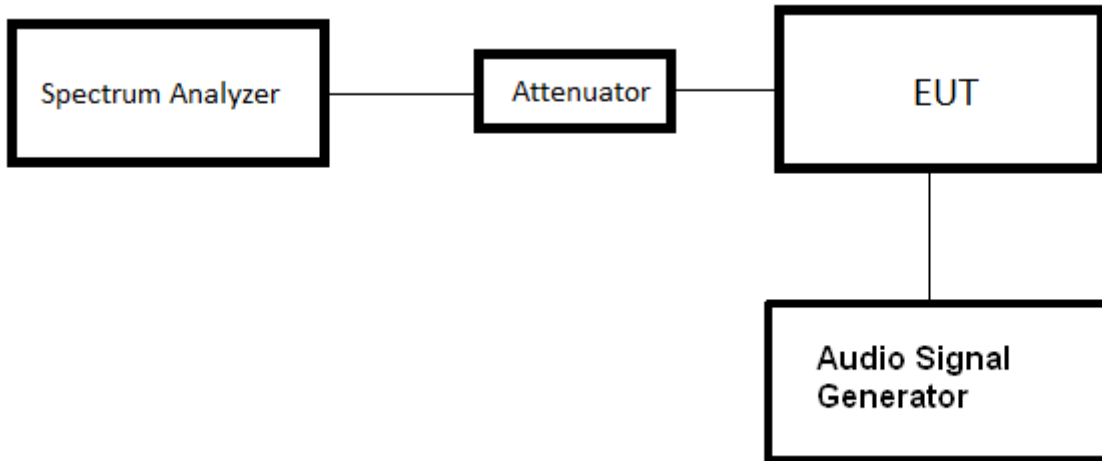



### 10.5 TEST RESULT

The maximum Conducted Power (CP) is  
4 W for 12.5 KHz Channel Separation  
4W for 25.0 KHz Channel Separation

<b>Conducted Power Measurement Results</b>		
<b>Channel Separation</b>	<b>Channel</b>	<b>Measurement Result (dBm)</b>
		<b>For 36dBm(4W)</b>
12.5 KHz	Bottom(406.2MHz)	36.43
	Middle(450.1MHz)	36.11
	Top (469.965MHz)	36.34
25 KHz	Bottom(406.2MHz)	36.44
	Middle(450.1MHz)	36.24
	Top (469.965MHz)	36.21

10.4 CONDUCT SPURIOUS PLOT

**Conduct Spurious Emission @ 406.2MHz (30MHz-1GHz)**

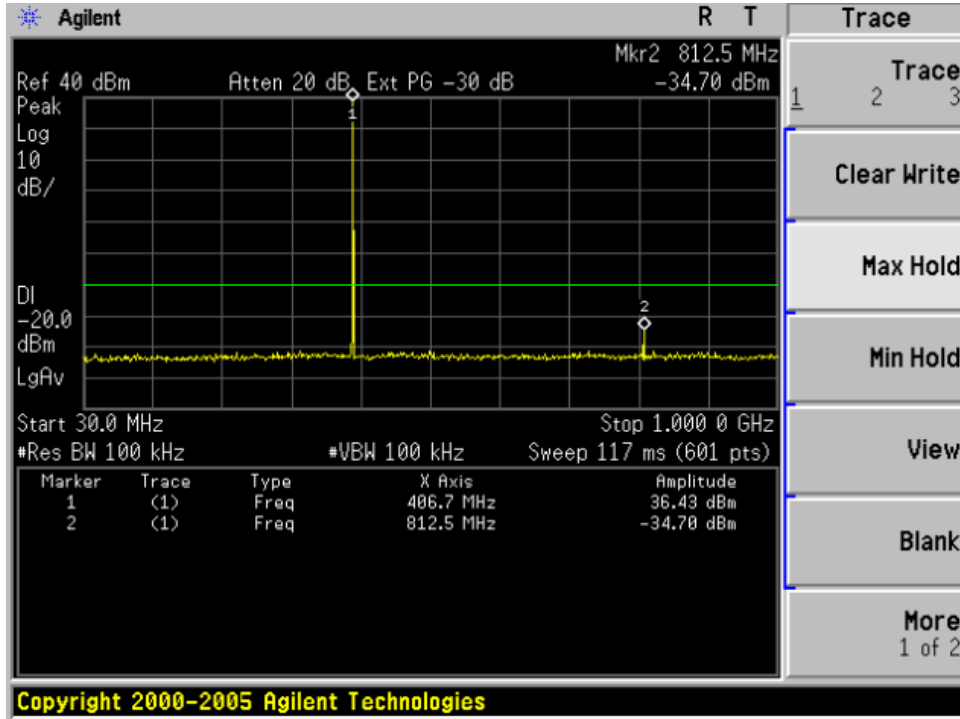

**Conduct Spurious Emission @ 406.2MHz (1GHz-6GHz)**

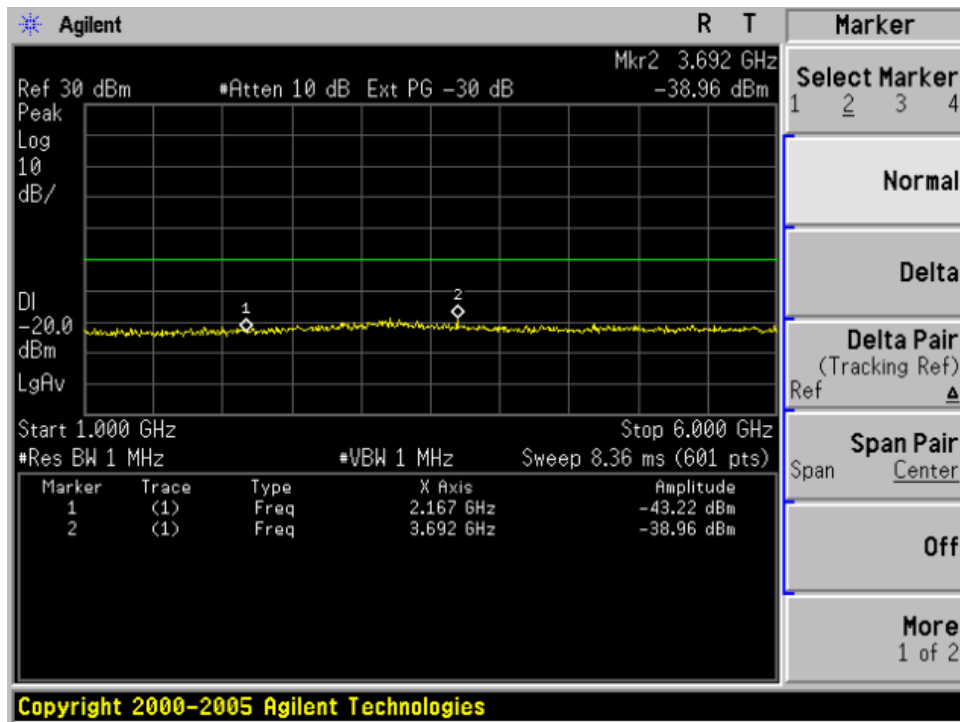

**Conduct Spurious Emission @ 450.1MHz (30MHz-1GHz)**

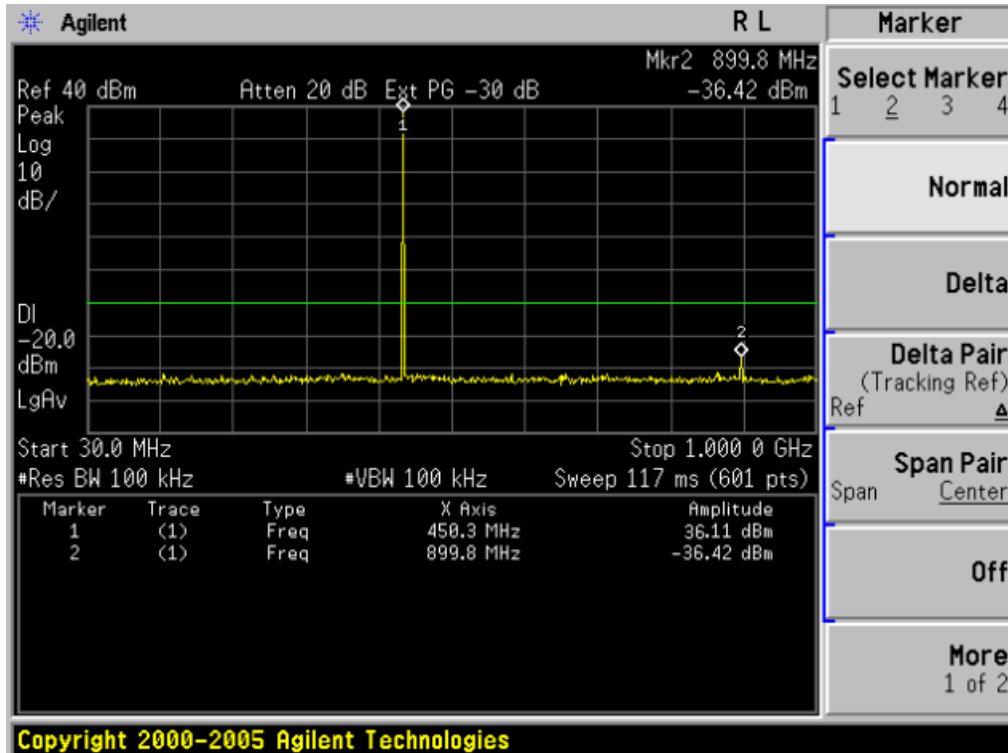

**Conduct Spurious Emission @ 450.1MHz (1GHz-6GHz)**

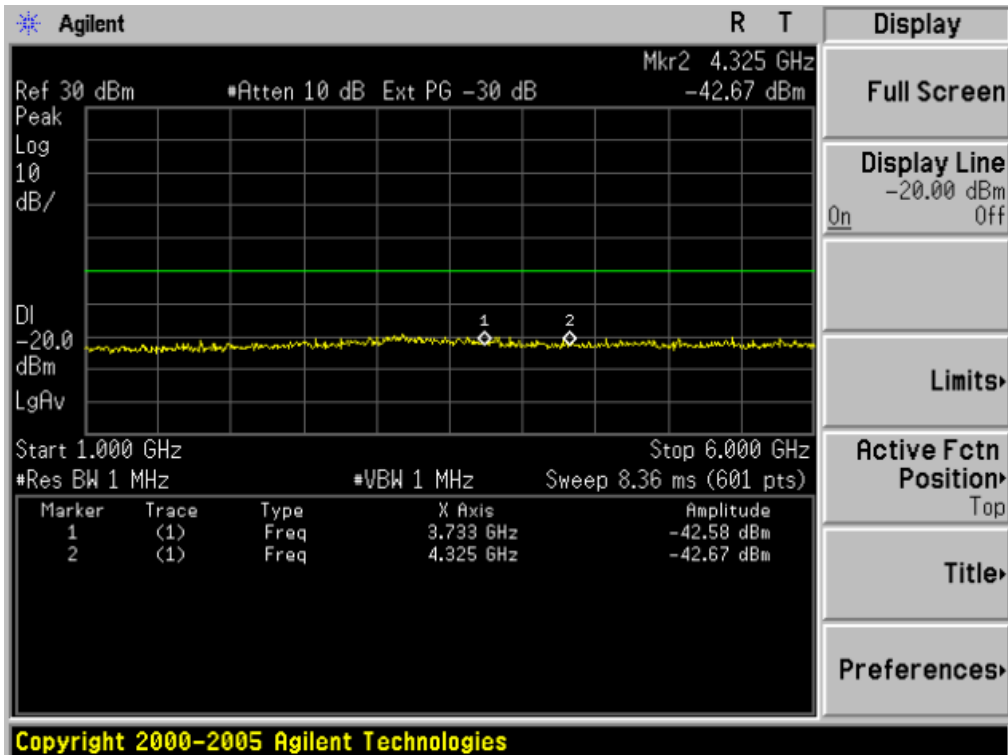

**Conduct Spurious Emission @ 469.965MHz (30MHz-1GHz)**

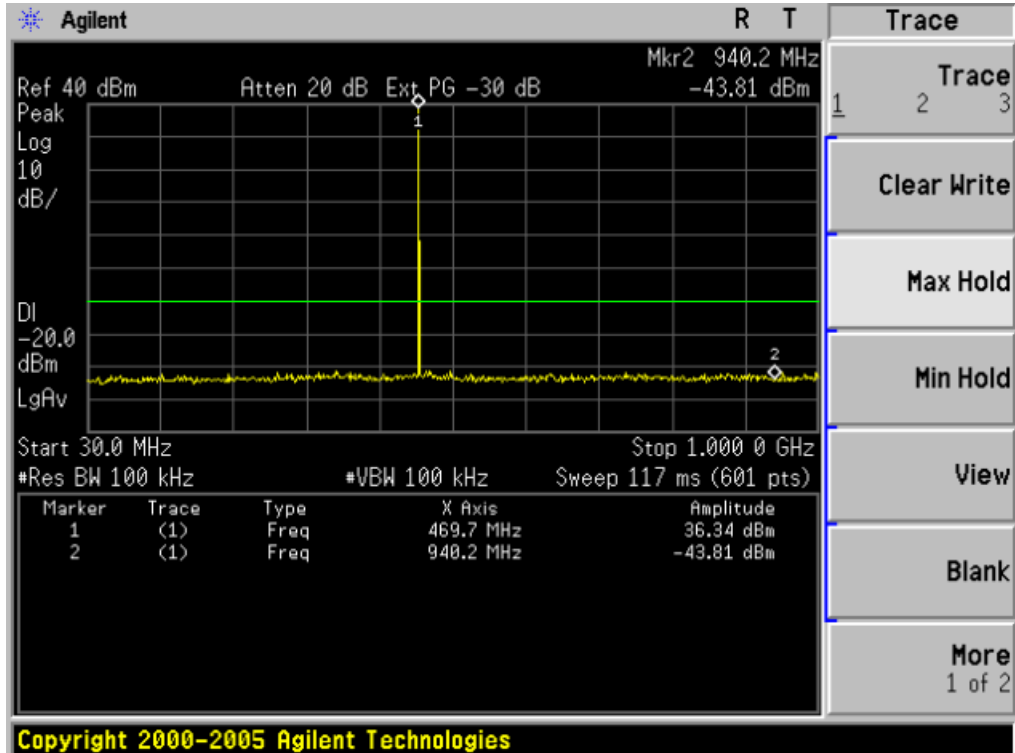

**Conduct Spurious Emission @ 469.965MHz (1GHz-6GHz)**

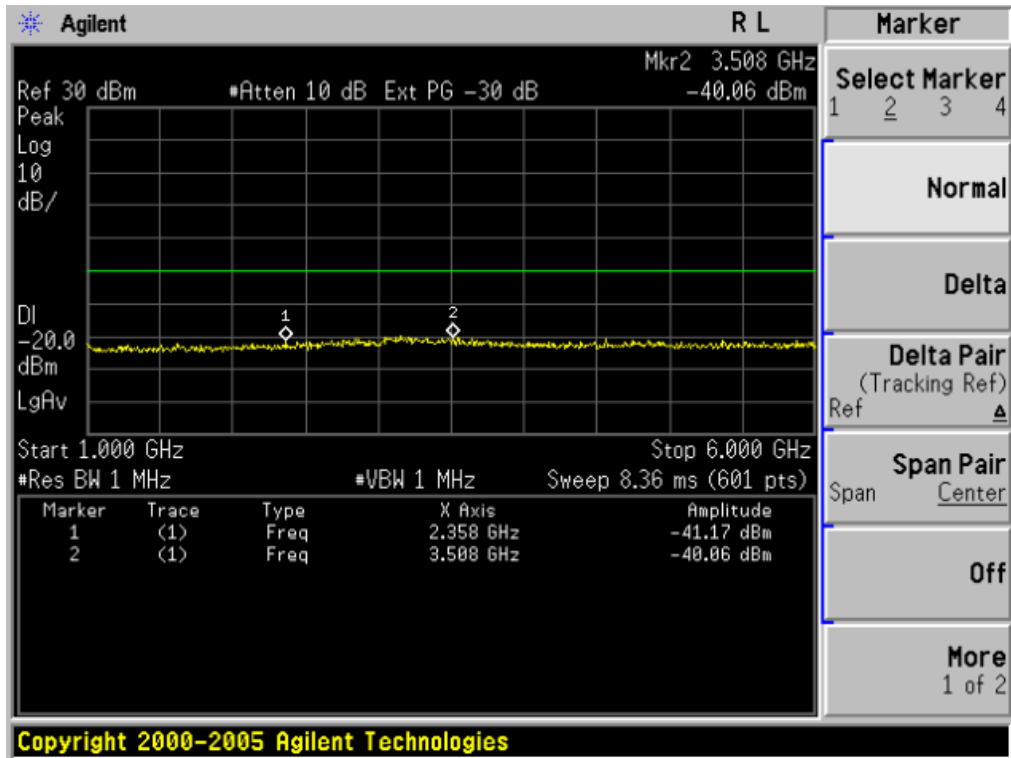

## 11. TRANSMITTER FREQUENCY BEHAVIOR

### 11.1 PROVISIONS APPLICABLE

Section 90.214

Time intervals <sup>1, 2</sup>	Maximum frequency difference <sup>3</sup>	All equipment	
		150 to 174 MHz	421 to 512 MHz
Transient Frequency Behavior for Equipment Designed to Operate on 25 kHz Channels			
t <sub>1</sub> <sup>4</sup> .....	± 25.0 kHz	5.0 ms	10.0 ms
t <sub>2</sub> .....	± 12.5 kHz	20.0 ms	25.0 ms
t <sub>3</sub> <sup>4</sup> .....	± 25.0 kHz	5.0 ms	10.0 ms
Transient Frequency Behavior for Equipment Designed to Operate on 12.5 kHz Channels			
t <sub>1</sub> <sup>4</sup> .....	± 12.5 kHz	5.0 ms	10.0 ms
t <sub>2</sub> .....	± 6.25 kHz	20.0 ms	25.0 ms
t <sub>3</sub> <sup>4</sup> .....	± 12.5 kHz	5.0 ms	10.0 ms
Transient Frequency Behavior for Equipment Designed to Operate on 6.25 kHz Channels			
t <sub>1</sub> <sup>4</sup> .....	± 6.25 kHz	5.0 ms	10.0 ms
t <sub>2</sub> .....	± 3.125 kHz	20.0 ms	25.0 ms
t <sub>3</sub> <sup>4</sup> .....	± 6.25 kHz	5.0 ms	10.0 ms

<sup>1</sup> t<sub>on</sub> is the instant when a 1 kHz test signal is completely suppressed, including any capture time due to phasing.

t<sub>1</sub> is the time period immediately following t<sub>on</sub>.

t<sub>2</sub> is the time period immediately following t<sub>1</sub>.

t<sub>3</sub> is the time period from the instant when the transmitter is turned off until t<sub>off</sub>.

t<sub>off</sub> is the instant when the 1 kHz test signal starts to rise.

<sup>2</sup> During the time from the end of t<sub>2</sub> to the beginning of t<sub>3</sub>, the frequency difference must not exceed the limits specified in §90.213.

<sup>3</sup> Difference between the actual transmitter frequency and the assigned transmitter frequency.

<sup>4</sup> If the transmitter carrier output power rating is 6 watts or less, the frequency difference during this time period may exceed the maximum frequency difference for this time period.

### 11.2 TEST METHOD

TIA/EIA-603 2.2.19

### 11.3 TEST INSTRUMENTS

NAME OF EQUIPMENT	MANUFACTURER	MODEL	SERIAL NUMBER	CAL. DATE
Signal Generator	R&S	SMT02	A0304261	2010.09
Storage Oscilloscope	Tektronix	TDS3052	B017447	2010.10

### 11.4 DESCRIBE LIMIT LINE OF TRANSMITTER FREQUENCY BEHAVIOR

**ton**: The switch-on instant  $t_{on}$  of a transmitter is defined by the condition when the output power, measured at the antenna terminal, exceeds 0,1 % of the full output power (-30 dBc).

**t1**: period of time starting at  $t_{on}$  and finishing according to above 11.1

**t2**: period of time starting at the end of  $t_1$  and finishing according to above 11.1

**toff**: switch-off instant defined by the condition when the output power falls below 0,1 % of the full output power (-30 dBc).

**t3**: period of time that finishing at  $t_{off}$  and starting according to above 11.1

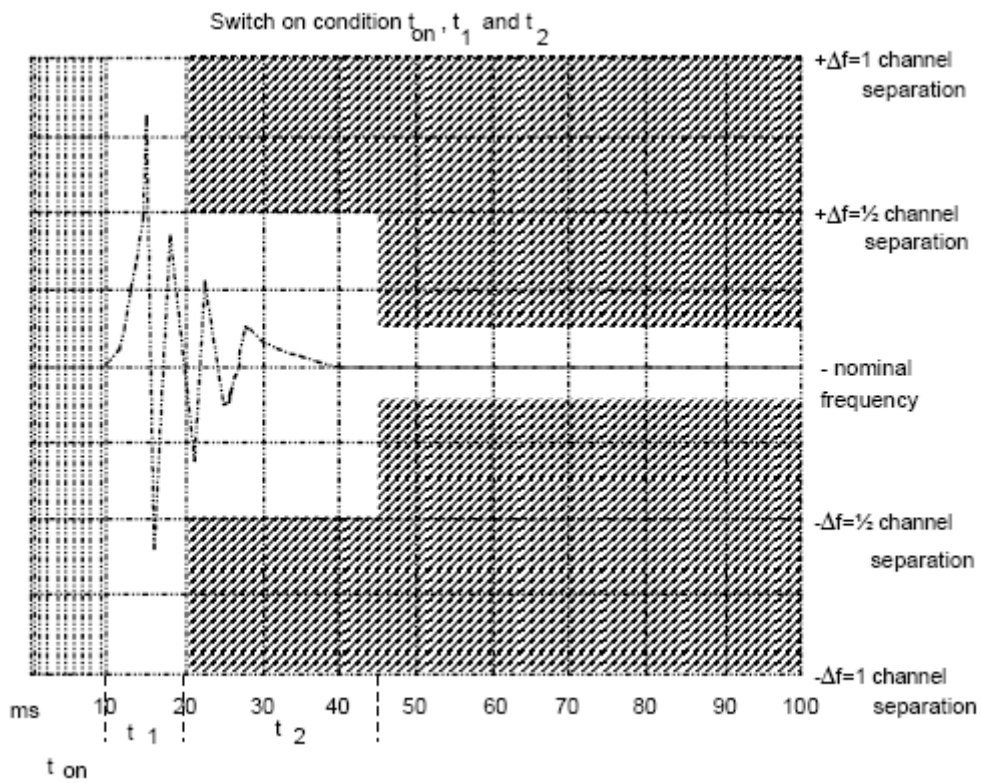

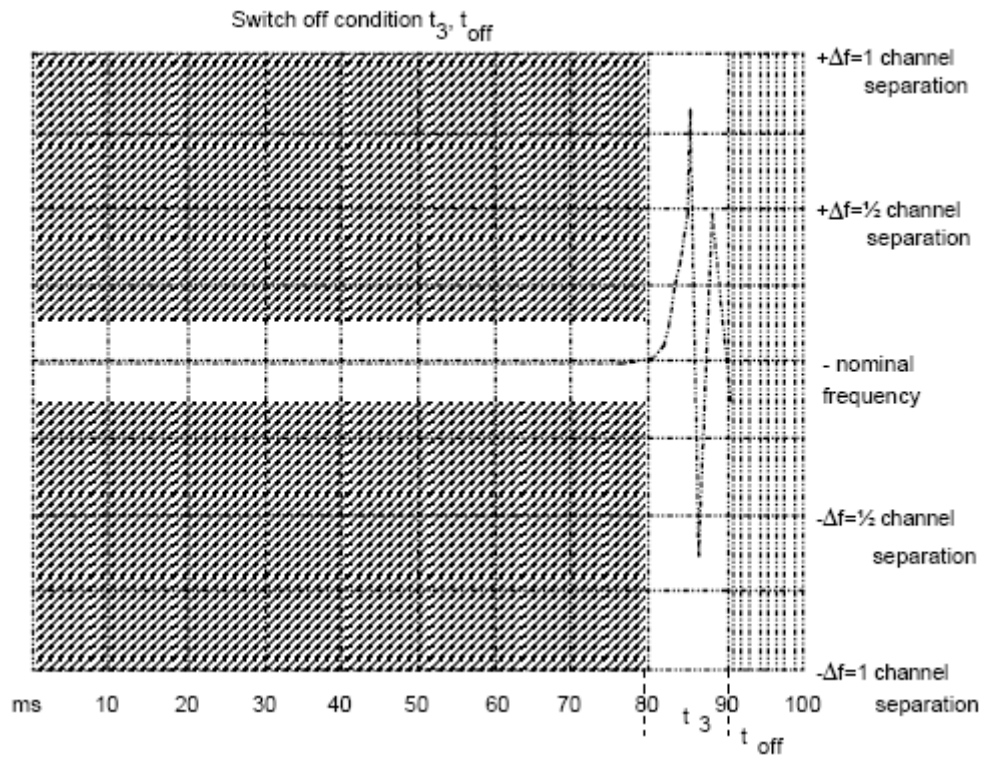

### 11.5 MEASURE RESULT

Transmitter Frequency Behavior @ 25 KHz Channel Separation--Off to On

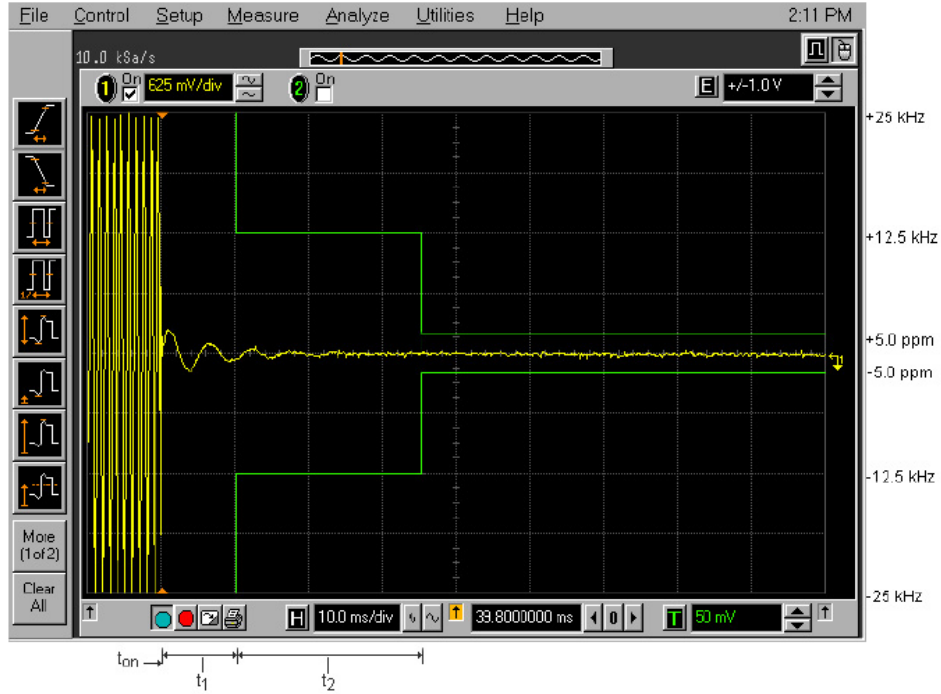

Transmitter Frequency Behaviour @ 25 KHz Channel Separation--On to Off

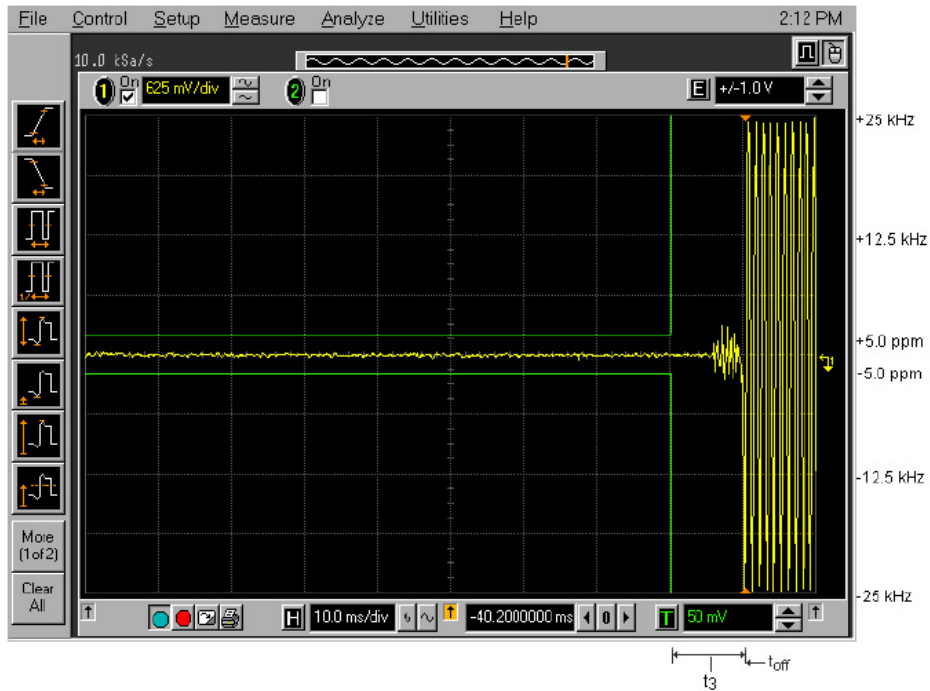



### Transmitter Frequency Behaviour @ 12.5 KHz Channel Separation--Off to On

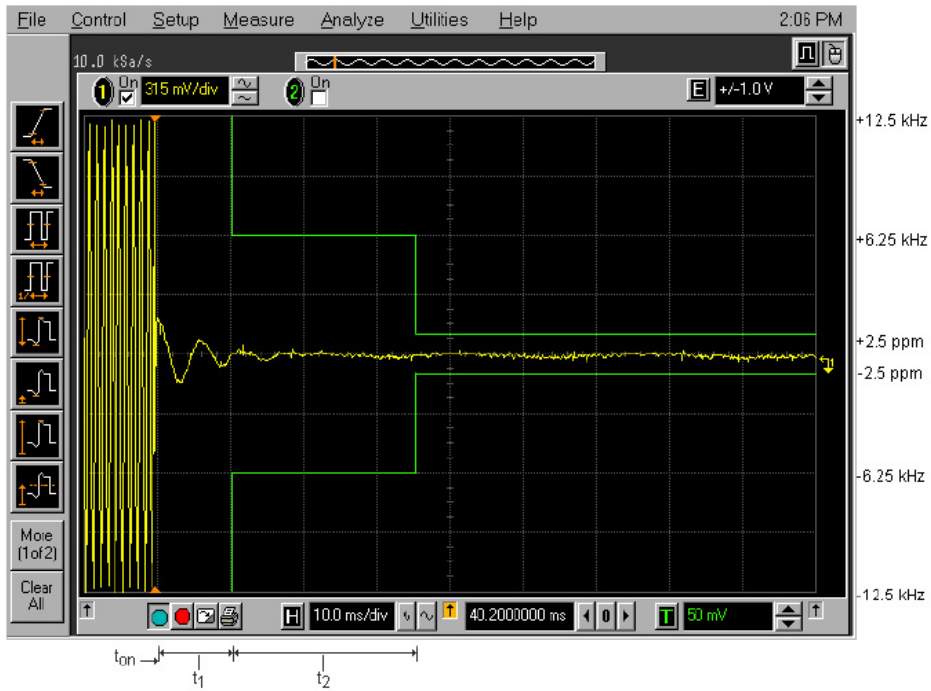

### Transmitter Frequency Behaviour @ 12.5 KHz Channel Separation--On to Off

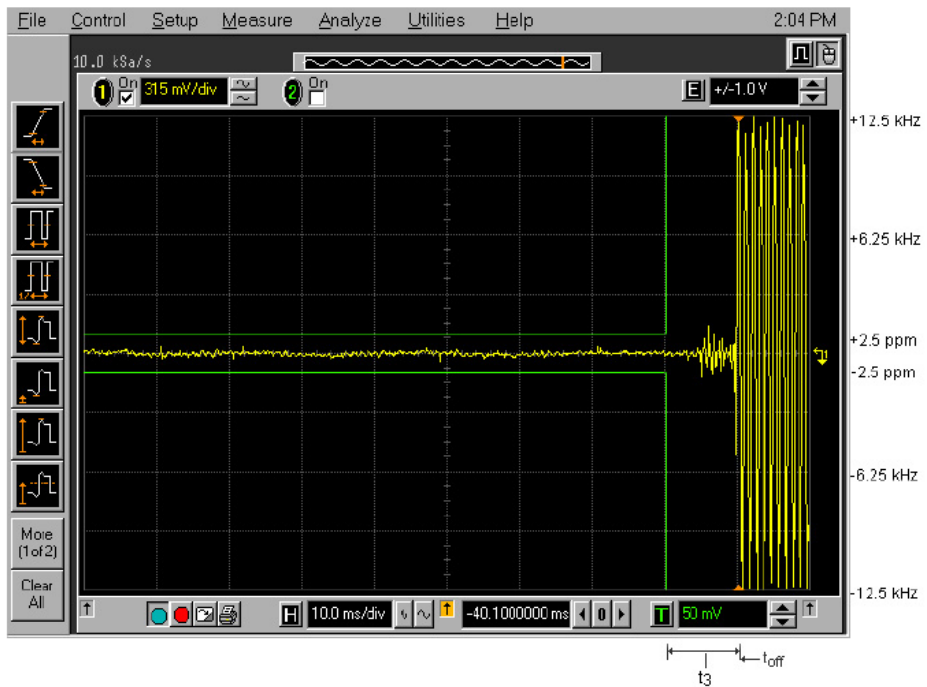

## 12. Radiated Emission on Receiving Mode

### 12.1 PROVISIONS APPLICABLE

FCC Part 15 Subpart B Section 15.109

### 12.2 TEST METHOD

ANSI C 63.4: 2003

### 12.3 TEST INSTRUMENTS

NAME OF EQUIPMENT	MANUFACTURER	MODEL	SERIAL NUMBER	CAL. DATE
SPECTRUM ANALYZER	AGILENT	E4440A	US44300399	2010.06
TEST RECEIVER	R&S	ESIB26	A0304218	2010.06
LOOP ANTENNA	R&S	HFH2-Z2	A0304220	2010.06
HORN ANT.	R&S	HF906	100150	2010.06
BROADBAND ANT.	R&S	HL562	A0304224	2010.06

**12.4 MEASURE RESULT (MEASURED AT 3M USING FCC PART15 B LIMITS)**  
**RADIATED EMISSION TEST RESULTS – HORIZONTAL**

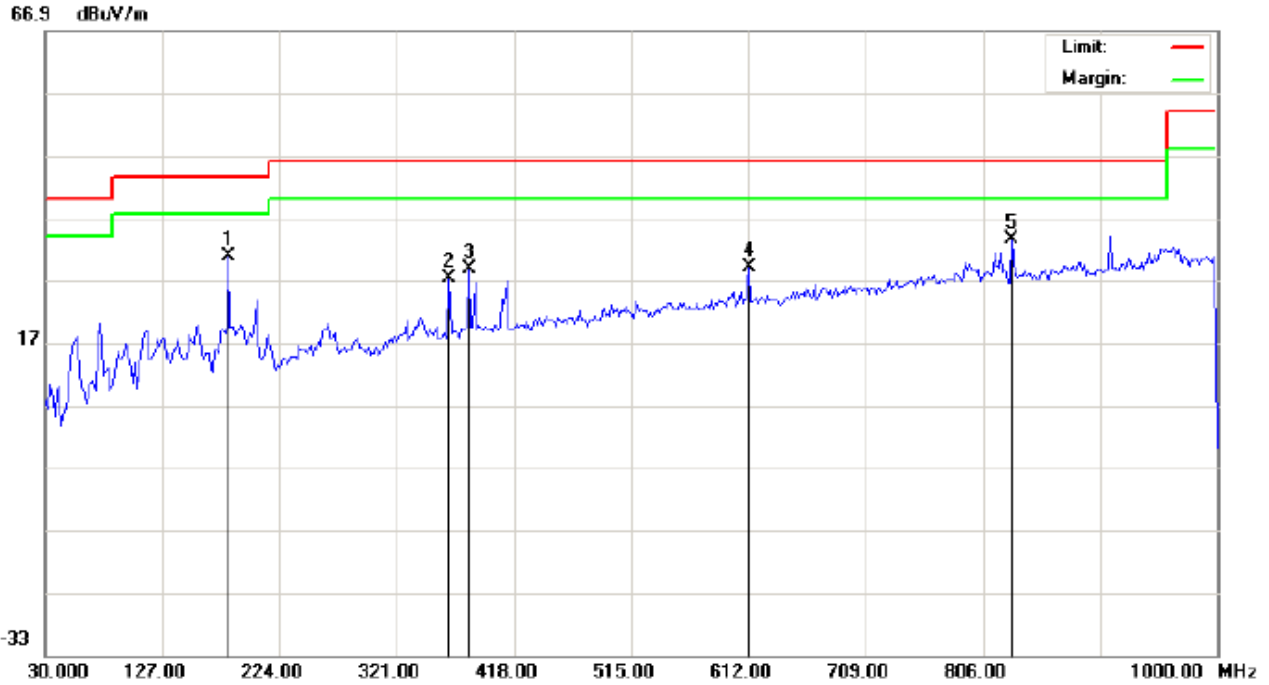

Site: site #1  
Limit: FCC Class B 3M Radiation  
EUT: Two way Radio  
M/N: CU600-2  
Mode: Receive  
Note:

Polarization: *Horizontal*  
Power: DC7.4V  
Distance: 3m

Temperature: 26  
Humidity: 60 %

No.	Mk	Freq.	Reading	Factor	Measurement	Limit	Over	Detector	Antenna Height	Table Degree	Comment
		MHz	dBuV	dB/m	dBuV/m	dBuV/m	dB		cm	degree	
1		181.9667	12.38	18.36	30.74	43.50	-12.76	peak			
2		364.6500	8.07	19.14	27.21	46.00	-18.79	peak			
3		380.8167	9.55	19.30	28.85	46.00	-17.15	peak			
4		612.0000	4.05	25.00	29.05	46.00	-16.95	peak			
5	*	830.2500	5.09	28.44	33.53	46.00	-12.47	peak			

RADIATED EMISSION TEST RESULTS – VERTICAL

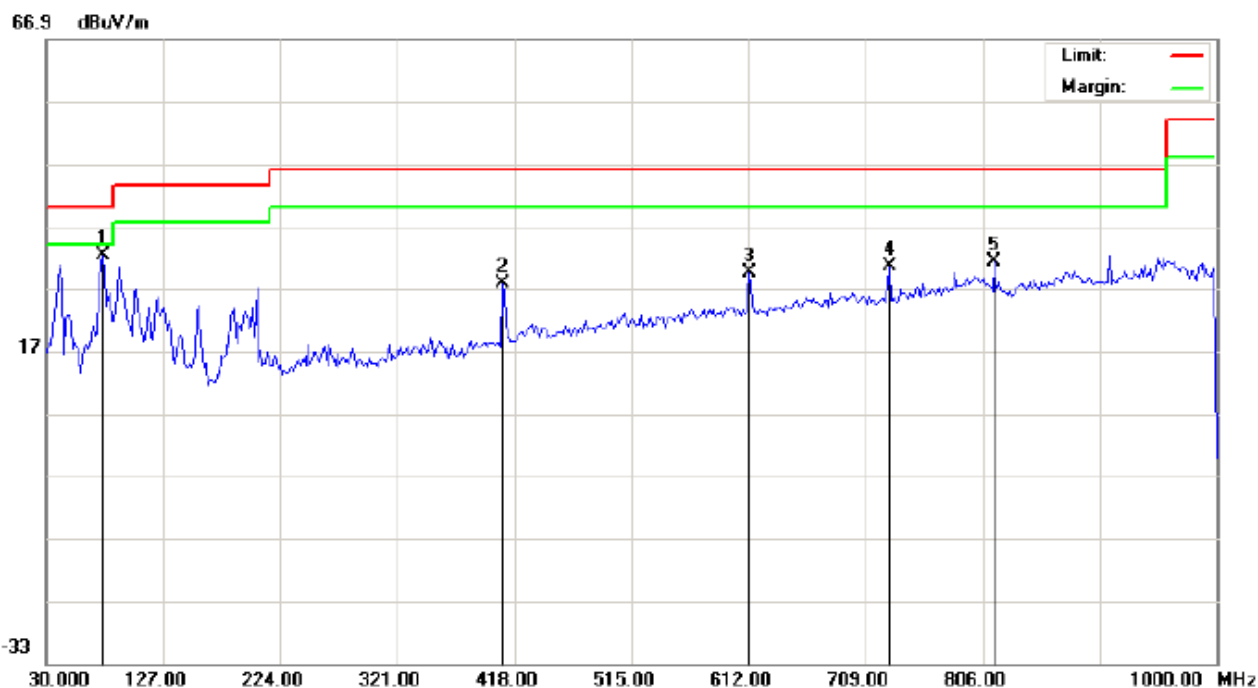

Site: site #1  
Limit: FCC Class B 3M Radiation  
EUT:Two way Radio  
M/N: CU600-2  
Mode: CHARGE  
Note:

Polarization: *Vertical*  
Power: DC7.4V  
Distance: 3m

Temperature: 26  
Humidity: 60 %

No.	Mk	Freq.	Reading	Factor	Measurement	Limit	Over	Detector	Antenna Height	Table Degree	Comment
		MHz	dBuV	dB/m	dBuV/m	dBuV/m	dB		cm	degree	
1	*	76.8833	24.28	7.90	32.18	40.00	-7.82	peak			
2		408.3000	6.81	21.08	27.89	46.00	-18.11	peak			
3		612.0000	4.63	25.00	29.63	46.00	-16.37	peak			
4		728.4000	3.78	26.69	30.47	46.00	-15.53	peak			
5		815.7000	2.83	28.53	31.36	46.00	-14.64	peak			

## 13. Audio Low Pass Filter Response

### 13.1 LIMITS

**2.1047(a):** Voice modulated communication equipment. A curve or equivalent data showing the frequency response of the audio modulating circuit over a range of 100 to 5000 Hz shall be submitted. For equipment required to have an audio low-pass filter, a curve showing the frequency response of the filter or of all circuitry installed between the modulation limiter and the modulated stage shall be submitted.

**90.242(b)(8):** Recommended audio filter attenuation characteristics are given below:

Audio band	Minimum Attenuation Rel. to 1 KHz Attenuation
3 –20 KHz 20 – 30 KHz	$60 \log_{10}(f/3)$ dB where f is in KHz 50dB

### 13.2. METHOD OF MEASUREMENTS

The rated audio input signal was applied to the input of the audio low-pass filter (or of all modulation stages) using an audio oscillator, this input signal level and its corresponding output signal were then measured and recorded using the FFT Digital Spectrum Analyzer. Tests were repeated at different audio signal frequencies from 0 to 50 KHz.

### 13.3 TEST DATA

**12.5 KHz Channel Spacing, F3E, Frequency of All Modulation States**

Frequency (KHz)	Audio In (dBV)	Audio Out (dBV)	Attenuation (Out - In) (dB)	Attenuation Rel. to 3 KHz (dB)	Recommended Attenuation (dB)
0.1	-75.79	-30.26	45.5	-36.9	--
0.2	-75.79	-18.84	57.0	-25.5	--
0.4	-75.79	-5.29	70.5	-12.0	--
0.6	-75.79	0.23	76.0	-6.4	--
0.8	-75.79	4.09	79.9	-2.6	--
1.0	-75.79	6.68	82.5	0.0	--
1.5	-75.79	8.75	84.5	2.1	--
2.0	-75.79	8.59	84.4	1.9	--
2.5	-75.79	7.13	82.9	0.5	--
3.0	-75.79	5.35	81.1	-1.3	0
3.5	-75.79	2.00	77.8	-4.7	-4
4.0	-75.79	-2.61	73.2	-9.3	-7
4.5	-75.79	-8.42	67.4	-15.1	-11
5.0	-75.79	-14.06	61.7	-20.7	-13
6.0	-75.79	-22.69	53.1	-29.4	-18
7.0	-75.79	-30.61	45.2	-37.3	-22
8.0	-75.79	-38.96	36.8	-45.6	-26
9.0	-75.79	-60.00	15.8	-66.7	-29
10.0	-75.79	-60.00	15.8	-66.7	-31
12.0	-75.79	-60.00	15.8	-66.7	-36
14.0	-75.79	-60.00	15.8	-66.7	-40
16.0	-75.79	-60.00	15.8	-66.7	-44
18.0	-75.79	-60.00	15.8	-66.7	-47
20.0	-75.79	-60.00	15.8	-66.7	-50
25.0	-75.79	-60.00	15.8	-66.7	-50
30.0	-75.79	-60.00	15.8	-66.7	-50
35.0	-75.79	-60.00	15.8	-66.7	-50
40.0	-75.79	-60.00	15.8	-66.7	-50
45.0	-75.79	-60.00	15.8	-66.7	-50
50.0	-75.79	-60.00	15.8	-66.7	-50

**Note:** Due to the difficulty of measuring the Frequency Response of the internal low-pass filter, the Frequency Response of All Modulation States is performed to show the roll-off at 3 KHz in comparison with the recommended audio filter attenuation.

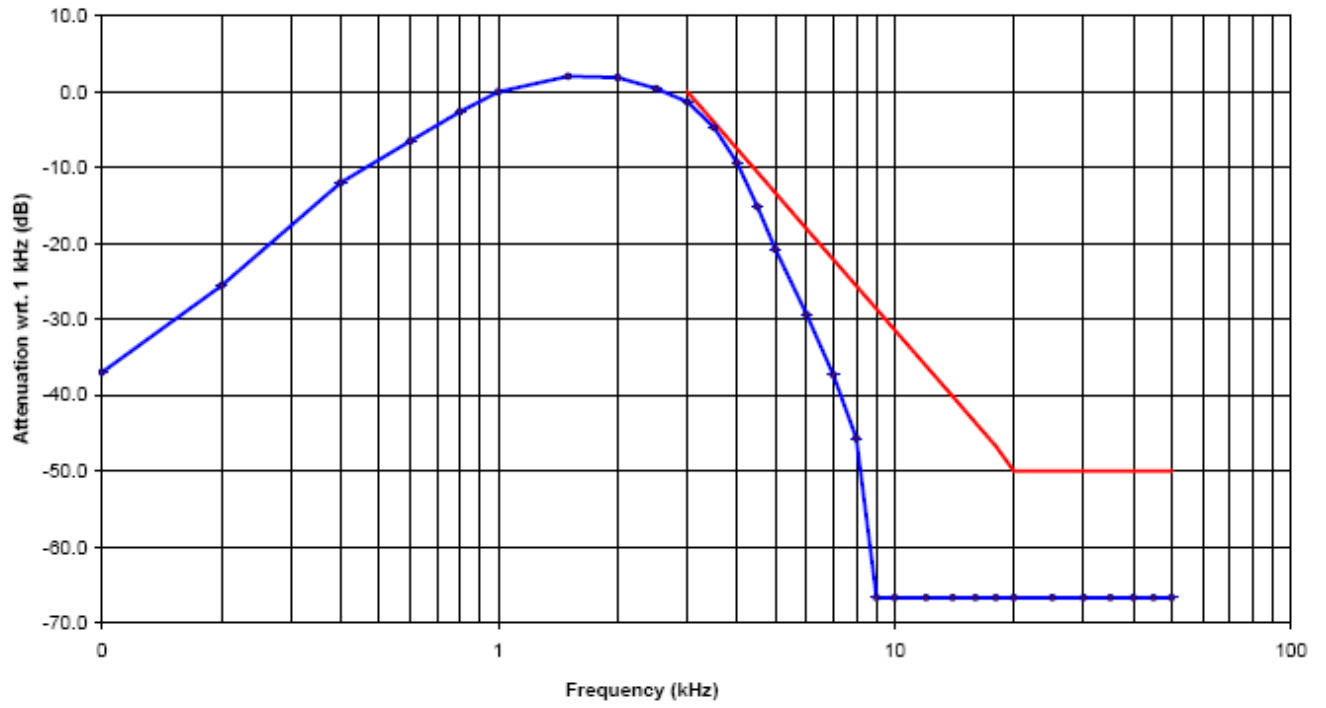

**25 KHz Channel Spacing, F3E, Frequency of All Modulation States**

Frequency (KHz)	Audio In (dBV)	Audio Out (dBV)	Attenuation (Out - In) (dB)	Attenuation Rel. to 3 KHz (dB)	Recommended Attenuation (dB)
0.1	-75.50	-36.46	39.0	-36.0	--
0.2	-75.50	-24.35	51.2	-23.9	--
0.4	-75.50	-11.86	63.6	-11.4	--
0.6	-75.50	-6.45	69.1	-6.0	--
0.8	-75.50	-2.74	72.8	-2.3	--
1.0	-75.50	-0.49	75.0	0.0	--
1.5	-75.50	2.43	77.9	2.9	--
2.0	-75.50	1.81	77.3	2.3	--
2.5	-75.50	-0.27	75.2	0.2	--
3.0	-75.50	-2.51	73.0	-2.0	0
3.5	-75.50	-6.44	69.1	-6.0	-4
4.0	-75.50	-13.51	62.0	-13.0	-7
4.5	-75.50	-20.97	54.5	-20.5	-11
5.0	-75.50	-25.87	49.6	-25.4	-13
6.0	-75.50	-35.11	40.4	-34.6	-18
7.0	-75.50	-60.00	15.5	-59.5	-22
8.0	-75.50	-60.00	15.5	-59.5	-26
9.0	-75.50	-60.00	15.5	-59.5	-29
10.0	-75.50	-60.00	15.5	-59.5	-31
12.0	-75.50	-60.00	15.5	-59.5	-36
14.0	-75.50	-60.00	15.5	-59.5	-40
16.0	-75.50	-60.00	15.5	-59.5	-44
18.0	-75.50	-60.00	15.5	-59.5	-47
20.0	-75.50	-60.00	15.5	-59.5	-50
25.0	-75.50	-60.00	15.5	-59.5	-50
30.0	-75.50	-60.00	15.5	-59.5	-50
35.0	-75.50	-60.00	15.5	-59.5	-50
40.0	-75.50	-60.00	15.5	-59.5	-50
45.0	-75.50	-60.00	15.5	-59.5	-50
50.0	-75.50	-60.00	15.5	-59.5	-50

**Note:** Due to the difficulty of measuring the Frequency Response of the internal low-pass filter, the Frequency Response of All Modulation States is performed to show the roll-off at 3 KHz in comparison with the recommended audio filter attenuation.



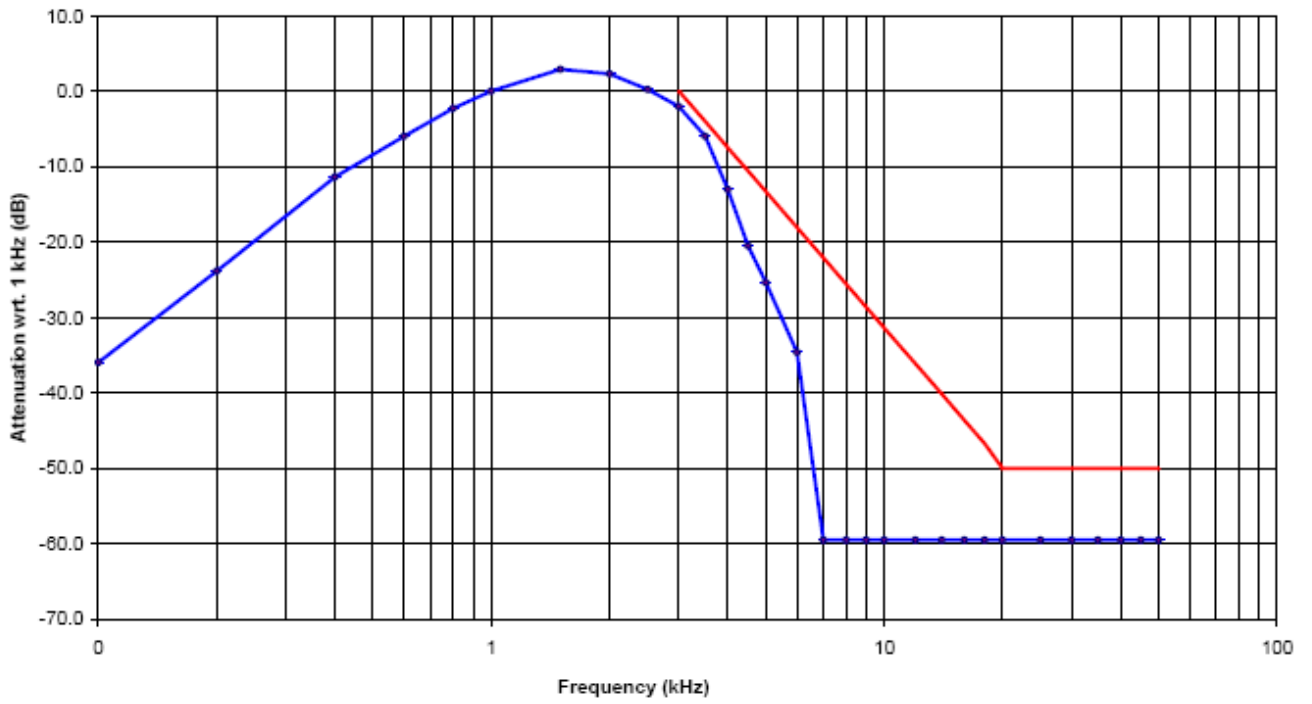

# **APPENDIX I**

## **PHOTOGRAPHS OF SETUP**

### CONDUCTED EMISSION TEST SETUP



### RADIATED TEST SETUP

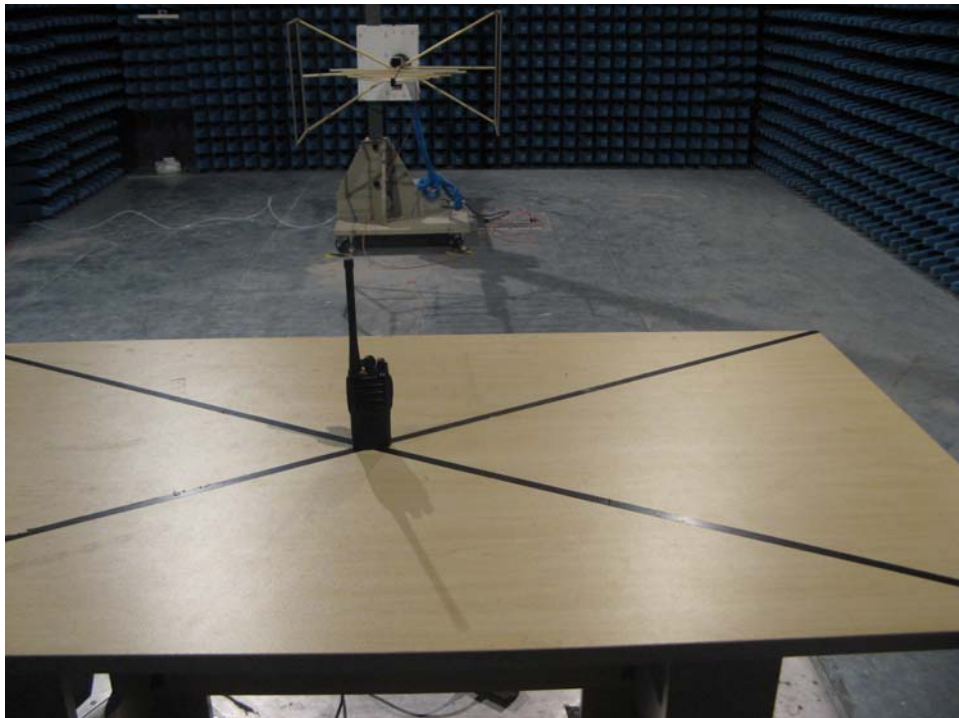

## **APPENDIX II**

### **EXTERNAL VIEW OF EUT**

TOP VIEW OF EUT



BOTTOM VIEW OF EUT



LEFT VIEW OF EUT



RIGHT VIEW OF EUT



FRONT VIEW OF EUT



BACK VIEW OF EUT



ALL VIEW





INTERNAL VIEW OF EUT - 1

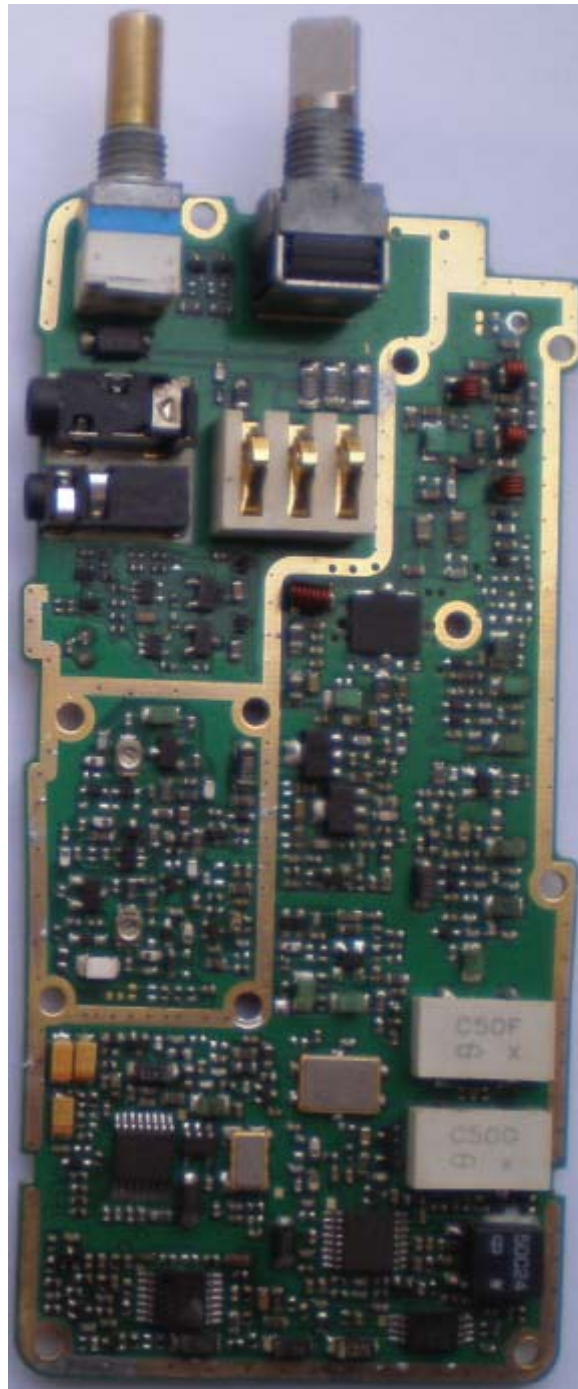

INTERNAL VIEW OF EUT - 2



Picture to show the antenna connector—1



Picture to show the antenna connector—2



Picture to show the circuit board placement in the EUT—1



Picture to show the circuit board placement in the EUT—2



----END OF REPORT----