

Circuit Description

1 SINGLE CHIP TRANSCEIVER

RDA1846 is one of the main components of the walkie-talkie.

The RDA1846 is a highly integrated single-chip transceiver for Walkie Talkie applications. It totally realizes the translation from RF carrier to voice in the RX path and from voice to RF carrier in the TX path, requiring only one micro controller.

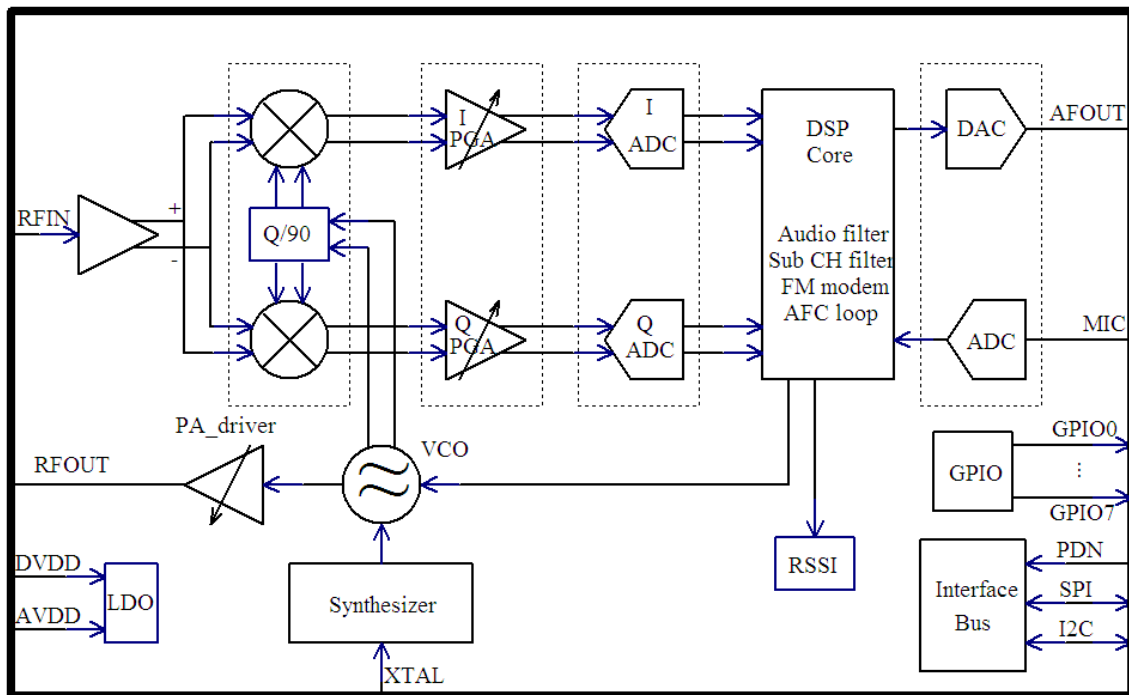

Figure 1 RDA1846 Block Diagram

2 Receiver (RX)

Front end

The RX signal from the antenna is passed through the LPF and antenna SW (D1, D4 and D5), and is sent to pin 15 of IC5 (RDA1846) to be demodulated and to output

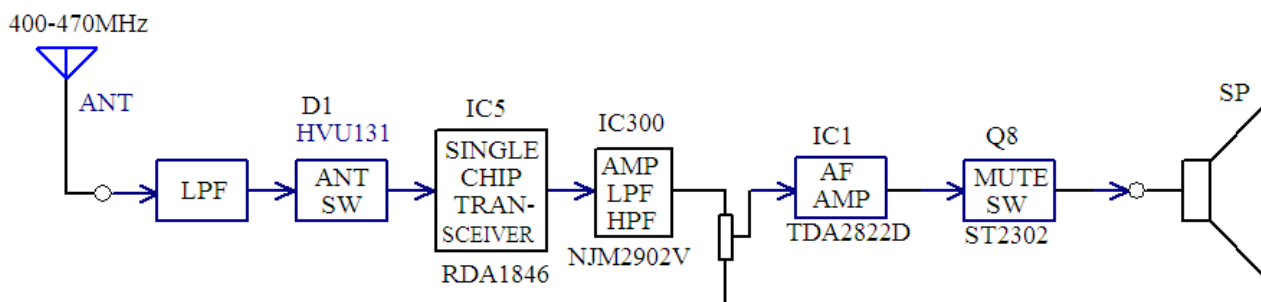

Figure 2 Receiver Diagram

Audio signal processing

The demodulated audio signal output from IC5 (RDA1846) passes through the volume potentiometer to be adjusted, and then goes to the audio power amplifier IC1 (TDA2822).

Squelch circuit

Output from pin 26 of IC5 (RDA1846) is sent to the MCU. MCU identifies the level of the noise and controls the squelch.

Audio power amplifier

The BTL type audio power amplifier circuit consists of IC1 and its peripheral components.

Base electrode of Q38 is the control terminal. High level: Open; Low level: Close.

The Rx audio signal, voice alert signal, alert tone signal and warning tone signal are collected and passed through the audio power amplifier where they are amplified and output to drive the speaker. The volume of the warning tone is not controlled by the preset volume level of the radio. Speaker impedance: 16Ω.

Note: Any terminal of the speaker should not be grounded!

CTCSS/DCS signal processing

CTCSS/DCS signal output from pin 32 of IC5 (RDA1846) is sent to MCU for decoding.

3 Transmitter (TX)

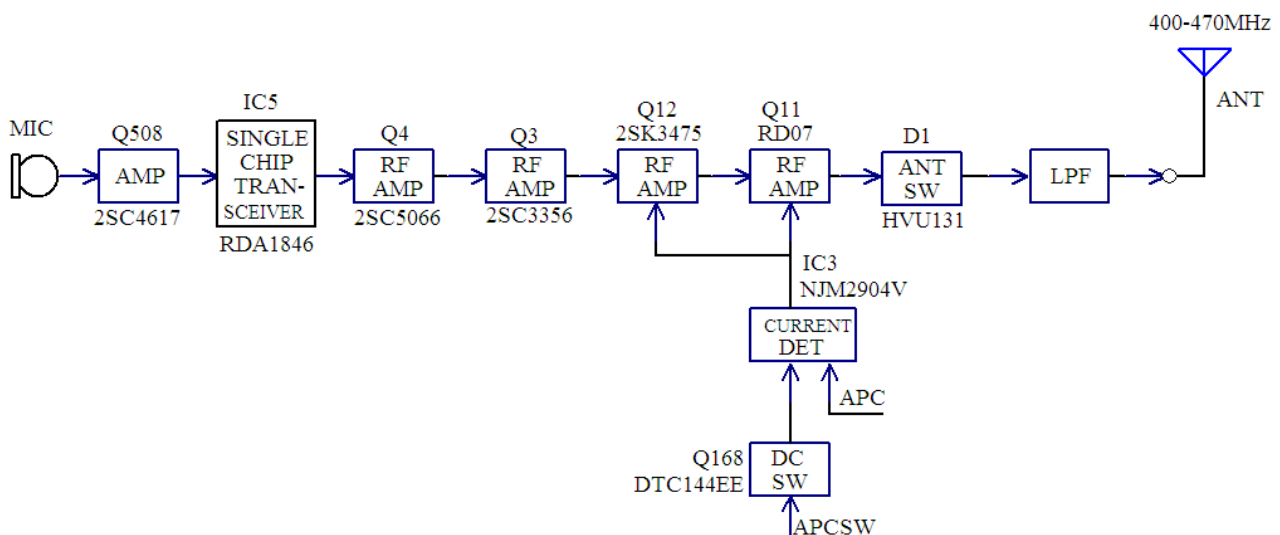

Figure 3 Transmitter Diagram

TX power amplification

The modulated RF signal from IC5 (RDA1846) is amplified by Q4, Q3 and Q12, and is sent to Q11 for power amplification. Output power of Q11: 4.0W.

Grid bias of Q12 and Q11 is controlled by the APC circuit. Through changing the grid bias voltage, the Tx output power can be controlled conveniently.

APC (Automatic Power Control)

R167, R168 and R169 are used to test the power amplification current. IC3A is the sampling amplifier for the power amplification current. IC3B is the power comparator amplifier.

If the Tx output power is too high, the power amplification current and IC3A output will increase; IC3B output voltage will decrease, so the offset voltage added to Q11 and Q12 will also decrease, which causes the Tx output power to be lowered, and vice versa. Thus the Tx output power can keep stable under different working conditions.

MCU can set the power through changing the voltage input to IC3B. Tx voice signal processing

MIC signal passes through the internal/external MIC switch circuit and is sent to pin 11 of IC5 (RDA1846) for carrier modulation.

4 Frequency Synthesizer

The 12.8MHz reference frequency signal provided by X1 is divided by the internal reference frequency divider of IC5 (RDA1846), and is then sent to the internal phase comparator of IC5, where the signal is compared with the signal divided by the fractional frequency divider of internal VCO. Then the output signal is used to control the internal VCO, enabling the frequency to reach the set value.

5 Power Supply

The radio uses 7.4V, 1700mAh Li-Poly battery. The Tx power amplification circuit (Q11 and Q12) and the Rx audio power amplifier (IC1) directly adopt the battery for power supply. Power of other circuits is supplied by 5V or 3.3V regulated voltage.

IC7:3,3V LDO, 3M power supply, and supplies power for RD1846 and MCU

IC8:5V LDO,5R and 5T power supply

Q29: 5T switch (controlled by MCU)

5T: supply power for the front end of transmitter

6 MCU Unit

MCU Unit controls the operation of every unit to realize all functions of the CU560-2.

Communication with external PC

State data access

Control PLL for the generation, receiving and transmitting of local oscillation frequency

Access to the current channel state

Control LED status indicator

Control power supplied condition of every unit

Detect action of every function key

Produce CTCSS signal

Produce DCS signal

Produce power controlled signal

Finish CTCSS decoding

Finish DCS decoding

Squelch detection and control

Control voice prompt content

Memory (FLASH)

Channel data, CTCSS/DCS data and other function setting data and parameter adjustment data.

CTCSS/DCS signal coding and decoding:

CTCSS/DCS signals from MCU (pin17 output) are sent to pin32 of IC5 for modulation respectively.

CTCSS/DCS signals from IC5 are sent to MCU(pin52) for decoding, and then MCU test if there are CTCSS/DCS signals with the same setting of the station to decide whether open the speaker or not.

CTCSS (continuous tone control squelch system, hereinafter referred to as CTCSS), is a kind of squelch control system with modulation on carrier and continuous sub-audio signals as pilot tone. If CTCSS function is set, the call is available only at the same CTCSS frequency of both receiving and transmitting parties to avoid the disturbance of other signals.

The station has 39 groups of standard CTCSS frequency for your selection, such as Table 1.

Table 1 CTCSS Frequency Table

No.	Frequency [Hz]	No.	Frequency [Hz]	No.	Frequency [Hz]	No.	Frequency [Hz]
1	67.0	11	94.8	21	131.8	31	186.2
2	69.3	12	97.4	22	136.5	32	192.8
3	71.9	13	100.0	23	141.3	33	203.5
4	74.4	14	103.5	24	146.2	34	210.7
5	77.0	15	107.2	25	151.4	35	218.1
6	79.7	16	110.9	26	156.7	36	225.7
7	82.5	17	114.8	27	162.2	37	233.6
8	85.4	18	118.8	28	167.9	38	241.8
9	88.5	19	123.0	29	173.8	39	250.3
10	91.5	20	127.3	30	179.9		

DCS signaling:

DCS (Digital code squelch), is a kind of continuous digital code modulated on carrier with voice signal and used for squelch control. If DCS function is set, the speaker is available only when receiving the same DCS code to avoid the disturbance of useless signals.

The station has 83 kinds of standard codes including positive and inverse code for your selection, such as Table 1

DCS signals produced by MCU (PWM waveform) are sent to IC5 for modulation.

CTCSS/DCS signals from receiver are sent to MCU for decoding, and then MCU test if there are DCS codes with the same setting of the station to decide whether open the speaker or not.

Table 1 DCS Coding Schedule

023	114	174	315	445	631
025	115	205	331	464	632
026	116	223	343	465	654
031	125	226	346	466	662
032	131	243	351	503	664
043	132	244	364	506	703
047	134	245	365	516	712
051	143	251	371	532	723
054	152	261	411	546	731
065	155	263	412	565	732
071	156	265	413	606	734
072	162	271	423	612	743
073	165	306	431	624	754
074	172	311	432	627	

7 Description of Semiconductor Devices

The distribution of each pin goes as the table 3.

Table 3---Definition of CPU Base Pin:

Pin No.	Port Name	Pin Name	I/O	Active Level	Function
1	APCSW	P33	O	H	APC switch
2	PTT	P34	O	L	PTT switch input
3	MODE	-	-	-	Connect this pin to VCC via a 4.7K resistor(*Burn)
4	SK1	P43	I	L	SIDE KEY1 input
5	SK2	P44	I	L	SIDE KEY2 input
6	RESET	-	I	L	CUP reset (*Burn)
7	XOUT	P47	O	-	MCU clock
8	VSS	-	-	-	GND
9	XIN	-	I	-	MCU clock
10	VCC	-	-	-	+5V
11	BSHIFT	P54	O	H	Beat shift switch
12	RDA_TXON	P53	I	H	TXON Active
13	F_CS	P52	O	L	FLASH chip select output
14	F_DI	P51	I	-	FLASH data in
15	F_CLK	P50	O	-	FLASH serial clock output
16	RDAPDN	P27	O	L	RDA Power Down Control
17	LSD	P26	I/O	-	CTCSS/DCS Input/Output
18	VCCN	P25	O	-	Frequency regulation output
19	F_DIO	P24	I/O	-	FLASH data input/output
20	GPS_EN	P23	O	-	GPS Enable Control
21	MIC_MUTE	P22	O	L	MIC mute L: MIC mute
22	NC	P21	I	-	Not Connected
23	RDA_RXON	P20	I	H	RXON Active

24	RDA_INT	P17	I	-	
25	MT_SCK	P16	O	-	MT Flash Clock
26	RXD0	P15	I	-	Serial data (PC, Wired Clone)
27	TXD0	P14	O	-	Serial data (PC, Wired Clone)
28	GLED	P86	O	H	Green LED
29	RLED	P85	O	H	Red LED
30	RXMUTE	P84	O	L	RX audio mute
31	TDIN	P83	I	TRFI	TONE data input
32	ALARMC	P82	O	L	Alarm switch control (H: Controlled by Volume Switch L: Emergency siren maximum volume)
33	RDADATA	P81	I/O	-	RDA Data Input/Output
34	RDACLK	P80	O	-	RDA Clock
35	NC	P60	O	-	Not Connected
36	RDA_EN	P45	O	L	RDA Latch Enable
37	MT_SO	P66	I	-	MT Flash Data Input
38	MT_SIO	P67	I/O	-	MT Flash Data Input/Output
39	Beep_AFCO	P65	O	H	Encode Modulation Enable
40	EXTPTT	P64	O	L	External PTT switch input
41	3TC	P63	O	H	Transmitting power control
42	SAVE	P31	O	L	Battery power control L: Power save
43	ENC0	P30	I	-	Channel selector input
44	ENC1	P36	I	-	Channel selector input
45	ENC2	P32	I	-	Channel selector input
46	ENC3	P13	I	-	Channel selector input
47	NC	P12	I	AN10	Not Connected
48	VOX	P11	I	AN9	VOX level input
49	BATT	P10	I	AN8	Battery voltage input
50	R_AUDIO	P00	I	AN7	Remote audio level input
51	L_AUDIO	P01	I	AN6	Local audio level input
52	DCS_IN	P02	I	-	CTCSS/DCS input Recording level input
53	MANDOWN	P03	I	AN4	Man down level input
54	BUSY	P04	I	AN3	Busy level input
55	TOPKEY	P62	I	L	TOPKEY input
56	AFCO	P61	O	H	Audio Amplification Power
57	NC	P05	I	AN2	Not Connected
58	PCTV	P06	O	DA0	APC/BPF control output
59	AVSS	-	I		GND
60	DTMF	P07	O	DA1	DTMF/MDC/Beep output
61	VREF	-	I		+5V
62	AVCC	-	I		+5V
63	SPKSW	P37	O	L	Audio amplifier control
64	MT_CS	P35	O	L	MT Flash Chip Select

Table 4 Functional description of semiconductor device

Item	Model	Function Description
IC1	TDA2822D	Audio Frequency Power Amplification
IC2	R5F212BCSNFP	MCU
IC3	NJM2904	APC, Voltage Comparison, Driving
IC5	RDA1846	Single-chip transceiver for Walkie Talkie
IC11	PST9124NR	MCU Reset Circuit
IC105	W25Q80	FLASH, Channel Frequency Data Storage, Function Setting Parameter, Debug Mode Parameter
IC300	NJM2902V	Receiver demodulated signal Amplification, Filtering