



**MET Laboratories, Inc.** *Safety Certification - EMI - Telecom Environmental Simulation*

914 WEST PATAPSCO AVENUE • BALTIMORE, MARYLAND 21230-3432 • PHONE (410) 354-3300 • FAX (410) 354-3313

33439 WESTERN AVENUE • UNION CITY, CALIFORNIA 94587 • PHONE (510) 489-6300 • FAX (510) 489-6372

3162 BELICK STREET • SANTA CLARA, CALIFORNIA 95054 • PHONE (408) 748-3585 • FAX (510) 489-6372

February 11, 2011

Spider Cloud Wireless  
231 Springside Drive, Suite 201  
Akron, OH 44333

Dear Jerry Shore,

Enclosed is the EMC Wireless test report for compliance testing of the Spider Cloud Wireless, SCR800 as tested to the requirements of the FCC Certification rules under Title 47 of the CFR Part 15, Subpart B, ICES-003, Issue 4 February 2004 for a Class A Digital Device, Part 24 Subpart E and RSS-133, Issue 5, February 2009 for Broadband PCS Devices.

Thank you for using the services of MET Laboratories, Inc. If you have any questions regarding these results or if MET can be of further service to you, please contact me.

Sincerely yours,  
MET LABORATORIES, INC.

Jennifer Warnell  
Documentation Department

Reference: (\Spider Cloud Wireless\EMC30395-FCC24 Rev. 1)

Certificates and reports shall not be reproduced except in full, without the written permission of MET Laboratories, Inc.



**MET Laboratories, Inc.** *Safety Certification - EMI - Telecom Environmental Simulation*

914 WEST PATAPSCO AVENUE • BALTIMORE, MARYLAND 21230-3432 • PHONE (410) 354-3300 • FAX (410) 354-3313

33439 WESTERN AVENUE • UNION CITY, CALIFORNIA 94587 • PHONE (510) 489-6300 • FAX (510) 489-6372

3162 BELICK STREET • SANTA CLARA, CALIFORNIA 95054 • PHONE (408) 748-3585 • FAX (510) 489-6372

**Electromagnetic Compatibility Criteria  
Test Report**

for the

**Spider Cloud Wireless  
Model SCR800**

**Tested under**

FCC Certification Rules

Title 47 of the CFR, Title 47 of the CFR, Parts 15 Subpart B & ICES-003  
for Class A Digital Devices

&

Part 24 Subpart E & RSS-133, Issue 5, February 2009  
for Broadband PCS Devices

**MET Report: EMC30395-FCC24 Rev. 1**

February 11, 2011

**Prepared For:**

**Spider Cloud Wireless  
231 Springside Drive, Suite 201  
Akron, OH 44333**

**Prepared By:**  
**MET Laboratories, Inc.**  
914 W. Patapsco Ave  
Baltimore, MD 21230



## Electromagnetic Compatibility Criteria Test Report

for the

### Spider Cloud Wireless Model SCRN800

#### Tested Under

FCC Certification Rules  
Title 47 of the CFR, Title 47 of the CFR, Parts 15 Subpart B & ICES-003  
for Class A Digital Devices  
&  
Part 24 Subpart E & RSS-133, Issue 5, February 2009  
for Broadband PCS Devices

Manasi Bhandiwad, Project Engineer  
Electromagnetic Compatibility Lab

Jennifer Warnell  
Documentation Department

**Engineering Statement:** The measurements shown in this report were made in accordance with the procedures indicated, and the emissions from this equipment were found to be within the limits applicable. I assume full responsibility for the accuracy and completeness of these measurements, and for the qualifications of all persons taking them. It is further stated that upon the basis of the measurements made, the equipment tested is capable of operation in accordance with the requirements of Part 15B and Part 24 Subpart E of the FCC Rules and Industry Canada standards ICES-003, Issue 4 February 2004 and RSS-133, Issue 5, February 2009 under normal use and maintenance.

Shawn McMillen, Wireless Manager  
Electromagnetic Compatibility Lab



## Report Status Sheet

Revision	Report Date	Reason for Revision
∅	February 1, 2011	Initial Issue.
1	February 11, 2011	Revised to reflect engineer corrections.



## Table of Contents

<b>I.</b>	<b>Executive Summary .....</b>	<b>1</b>
	A. Purpose of Test .....	2
	B. Executive Summary .....	2
<b>II.</b>	<b>Equipment Configuration .....</b>	<b>3</b>
	A. Overview .....	4
	B. References .....	5
	C. Test Site .....	5
	D. Description of Test Sample .....	5
	E. Equipment Configuration .....	7
	F. Support Equipment .....	7
	G. Ports and Cabling Information .....	8
	H. Mode of Operation .....	8
	I. Modifications .....	8
	Modifications to EUT .....	8
	Modifications to Test Standard .....	8
	J. Disposition of EUT .....	8
<b>III.</b>	<b>Electromagnetic Compatibility Criteria for Unintentional Radiators .....</b>	<b>9</b>
	§ 15.107(a) Conducted Emissions Limits .....	10
	§ 15.109(a) Radiated Emissions Limits .....	14
<b>IV.</b>	<b>Electromagnetic Compatibility Criteria for Intentional Radiators .....</b>	<b>18</b>
	§ 2.1046 RF Power Output .....	19
	§ 2.1049 Occupied Bandwidth .....	23
	§ 2.1051 Spurious Emissions at Antenna Terminals .....	26
	§ 2.1053 Radiated Spurious Emissions .....	31
	RSS-GEN Receiver Spurious Emissions .....	40
	§2.1055 Frequency Stability .....	45
<b>V.</b>	<b>Test Equipment .....</b>	<b>54</b>
<b>VI.</b>	<b>Certification &amp; User’s Manual Information .....</b>	<b>56</b>
	A. Certification Information .....	57
	B. Label and User’s Manual Information .....	61



## List of Tables

Table 1. Executive Summary of EMC Compliance Testing .....	2
Table 2. EUT Summary Table.....	4
Table 3. Standard References .....	5
Table 4. Equipment Configuration .....	7
Table 5. Support Equipment.....	7
Table 6. Ports and Cabling Information .....	8
Table 7. Conducted Limits for Radio Frequency Devices calculated from FCC Part 15 Subsections 15.107(a) (b) and 15.207(a) .....	10
Table 8. Conducted Emissions - Voltage, AC Power, Phase Line (120 VAC, 60 Hz).....	11
Table 9. Conducted Emissions - Voltage, AC Power, Neutral Line (120 VAC, 60 Hz).....	12
Table 10. Radiated Emissions Limits calculated from FCC Part 15, §15.109 (a) (b) .....	14
Table 11. Radiated Emissions Limits, Test Results, 30 MHz – 1 GHz, FCC Limits .....	15
Table 12. Radiated Emissions Limits, Test Results, ICES-003 Limits .....	16
Table 13. RF Output Power, Test Results .....	20
Table 14. Peak/Average Ratio.....	20
Table 15. Spurious Emission Limits for Receivers .....	40
Table 16. Test Equipment List .....	55

## List of Figures

Figure 1. Block Diagram of Test Configuration.....	6
Figure 2. Block Diagram, Conducted Receiver Spurious Emissions Test Setup .....	40



## List of Plots

Plot 1. Conducted Emission, Phase Line Plot .....	11
Plot 2. Conducted Emission, Neutral Line Plot.....	12
Plot 3. Radiated Emissions, 30 MHz - 1 GHz, FCC Limits .....	15
Plot 4. Radiated Emissions, ICES-003 Limits.....	16
Plot 5. RF Output Power, Low Channel, Average .....	21
Plot 6. Output Power, Low Channel, Peak .....	21
Plot 7. RF Output Power, Mid Channel, Average .....	21
Plot 8. Output Power, Mid Channel, Peak.....	22
Plot 9. RF Output Power, High Channel, Average.....	22
Plot 10. Output Power, High Channel, Peak .....	22
Plot 11. Occupied Bandwidth, Low Channel .....	24
Plot 12. Occupied Bandwidth, Mid Channel.....	24
Plot 13. Occupied Bandwidth, High Channel.....	24
Plot 14. 99% Occupied Bandwidth, Low Channel .....	25
Plot 15. 99% Occupied Bandwidth, Mid Channel.....	25
Plot 16. 99% Occupied Bandwidth, High Channel .....	25
Plot 17. Spurious Emissions at Antenna Terminal, Low Channel, 30 MHz – 1 GHz.....	27
Plot 18. Spurious Emissions at Antenna Terminal, Low Channel, 1 GHz – 26.5 GHz.....	27
Plot 19. Spurious Emissions at Antenna Terminal, Mid Channel, 30 MHz – 1 GHz.....	28
Plot 20. Spurious Emissions at Antenna Terminal, Mid Channel, 1 GHz – 26.5 GHz .....	28
Plot 21. Spurious Emissions at Antenna Terminal, High Channel, 30 MHz – 1 GHz .....	29
Plot 22. Spurious Emissions at Antenna Terminal, High Channel, 1 GHz – 26.5 GHz .....	29
Plot 23. Band Edge, Low Channel .....	30
Plot 24. Band Edge, High Channel.....	30
Plot 25. Radiated Spurious Emissions, Low Channel, 30 MHz – 1 GHz.....	33
Plot 26. Radiated Spurious Emissions, Low Channel, 1 GHz – 3 GHz .....	33
Plot 27. Radiated Spurious Emissions, Low Channel, 3 GHz – 6 GHz .....	33
Plot 28. Radiated Spurious Emissions, Low Channel, 6 GHz – 18 GHz .....	34
Plot 29. Radiated Spurious Emissions, Mid Channel, 30 MHz – 1 GHz .....	35
Plot 30. Radiated Spurious Emissions, Mid Channel, 1 GHz – 3 GHz .....	35
Plot 31. Radiated Spurious Emissions, Mid Channel, 3 GHz – 6 GHz .....	35
Plot 32. Radiated Spurious Emissions, Mid Channel, 6 GHz – 18 GHz .....	36
Plot 33. Radiated Spurious Emissions, High Channel, 30 MHz – 1 GHz .....	37
Plot 34. Radiated Spurious Emissions, High Channel, 1 GHz – 3 GHz.....	37
Plot 35. Radiated Spurious Emissions, High Channel, 3 GHz – 6 GHz.....	37
Plot 36. Radiated Spurious Emissions, High Channel, 6 GHz – 18 GHz.....	38
Plot 37. Receiver Spurious Emissions, Mid Channel, Downlink, 30 MHz – 1 GHz.....	41
Plot 38. Receiver Spurious Emissions, Mid Channel, Downlink, 1 GHz – 6 GHz .....	41
Plot 39. Receiver Spurious Emissions, GSM 1900 Band, 30 MHz – 1 GHz .....	42
Plot 40. Receiver Spurious Emissions, GSM 1900 Band, 1 GHz – 6 GHz.....	42
Plot 41. Receiver Spurious Emissions, Mid Channel, GSM 850, 30 MHz – 1 GHz.....	43
Plot 42. Receiver Spurious Emissions, Mid Channel, GSM 850, 1 GHz – 6 GHz.....	43
Plot 43. Receiver Spurious Emissions, Mid Channel, Uplink, 30 MHz – 1 GHz .....	44
Plot 44. Receiver Spurious Emissions, Mid Channel, Uplink, 1 GHz – 6 GHz .....	44
Plot 45. Frequency Stability, Low Band Edge, -30°C.....	46
Plot 46. Frequency Stability, Low Band Edge, -20°C.....	46
Plot 47. Frequency Stability, Low Band Edge, -10°C.....	46
Plot 48. Frequency Stability, Low Band Edge, 0°C .....	47
Plot 49. Frequency Stability, Low Band Edge, 10°C .....	47
Plot 50. Frequency Stability, Low Band Edge, 20°C .....	47
Plot 51. Frequency Stability, Low Band Edge, 30°C .....	48



Plot 52. Frequency Stability, Low Band Edge, 40°C .....	48
Plot 53. Frequency Stability, Low Band Edge, 50°C .....	48
Plot 54. Frequency Stability, Normal, Low Band Edge, Low Voltage .....	49
Plot 55. Frequency Stability, Normal, Low Band Edge, High Voltage .....	49
Plot 56. Frequency Stability, Normal, High Band Edge, Low Voltage .....	49
Plot 57. Frequency Stability, Normal, High Band Edge, High Voltage .....	50
Plot 58. Frequency Stability, High Band Edge, -30°C .....	50
Plot 59. Frequency Stability, High Band Edge, -20°C .....	50
Plot 60. Frequency Stability, High Band Edge, -10°C .....	51
Plot 61. Frequency Stability, High Band Edge, 0°C .....	51
Plot 62. Frequency Stability, High Band Edge, 10°C .....	51
Plot 63. Frequency Stability, High Band Edge, 20°C .....	52
Plot 64. Frequency Stability, High Band Edge, 30°C .....	52
Plot 65. Frequency Stability, High Band Edge, 40°C .....	52
Plot 66. Frequency Stability, High Band Edge, 50°C .....	53

## List of Photographs

Photograph 1. Conducted Emissions, Test Setup .....	13
Photograph 2. Radiated Emission, Test Setup .....	17
Photograph 3. Radiated Emissions, Test Setup 1 .....	39
Photograph 4. Radiated Emissions, Test Setup 2 .....	39





## List of Terms and Abbreviations

AC	Alternating Current
ACF	Antenna Correction Factor
Cal	Calibration
<i>d</i>	Measurement Distance
dB	Decibels
dB $\mu$ A	Decibels above one <b>microamp</b>
dB $\mu$ V	Decibels above one <b>microvolt</b>
dB $\mu$ A/m	Decibels above one <b>microamp per meter</b>
dB $\mu$ V/m	Decibels above one <b>microvolt per meter</b>
DC	Direct Current
E	Electric Field
DSL	Digital Subscriber Line
ESD	Electrostatic Discharge
EUT	Equipment Under Test
<i>f</i>	Frequency
FCC	Federal Communications Commission
GRP	Ground Reference Plane
H	Magnetic Field
HCP	Horizontal Coupling Plane
Hz	Hertz
IEC	International Electrotechnical Commission
kHz	kilohertz
kPa	kilopascal
kV	kilovolt
LISN	Line Impedance Stabilization Network
MHz	Megahertz
$\mu$ H	microhenry
$\mu$	microfarad
$\mu$ s	microseconds
NEBS	Network Equipment-Building System
PRF	Pulse Repetition Frequency
RF	Radio Frequency
RMS	Root-Mean-Square
TWT	Traveling Wave Tube
V/m	Volts <b>per meter</b>
VCP	Vertical Coupling Plane



# I. Executive Summary



**A. Purpose of Test**

An EMC evaluation was performed to determine compliance of the Spider Cloud Wireless SCR800, with the requirements of Part 24 Subpart E and Part 15 Subpart B. All references are to the most current version of Title 47 of the Code of Federal Regulations in effect. In accordance with §2.1033, the following data is presented in support of the Certification of the SCR800. Spider Cloud Wireless should retain a copy of this document which should be kept on file for at least two years after the manufacturing of the SCR800, has been **permanently** discontinued.

**B. Executive Summary**

The following tests were conducted on a sample of the equipment for the purpose of demonstrating compliance with Part 24 Subpart E and Part 15 Subpart B, in accordance with Spider Cloud Wireless, purchase order number 1906.

Reference	IC Reference	Description	Compliance
47 CFR Part 15.107 (a)	ICES-003 Issue 4 February 2004	Conducted Emission Limits for a Class A Digital Device	Compliant
47 CFR Part 15.109 (a)	ICES-003 Issue 4 February 2004	Radiated Emission Limits for a Class A Digital Device	Compliant
§2.1046; §24.232	RSS-133, Section 6.4	RF Power Output	Compliant
§2.1049	RSS-GEN, Section 4.6	Occupied Bandwidth	Compliant
§2.1051; §24.238	RSS-133, Section 6.5	Conducted Spurious Emissions at Antenna Terminals	Compliant
§2.1053; §24.238	RSS-133, Section 6.5	Radiated Spurious Emissions from the Cabinet	Compliant
N/A	RSS-GEN	Receiver Spurious Emissions	Compliant
§2.1055; §24.135	RSS-133, Section 6.3	Frequency Stability	Compliant

**Table 1. Executive Summary of EMC Compliance Testing**

## II. Equipment Configuration

## A. Overview

MET Laboratories, Inc. was contracted by Spider Cloud Wireless to perform testing on the SCRN800, under Spider Cloud Wireless's purchase order number 1906.

This document describes the test setups, test methods, required test equipment, and the test limit criteria used to perform compliance testing of the Spider Cloud Wireless, SCRN800.

The results obtained relate only to the item(s) tested.

<b>Model(s) Tested:</b>	SCRN800	
<b>Model(s) Covered:</b>	SCRN800	
<b>EUT Specifications:</b>	Primary Power: 120 VAC, 60 Hz	
	Type of Modulations:	WCDMA 3.84 MCPS 64DCPH
	Equipment Code:	PCB
	RF Output Power:	21.33 dBm
	EUT Frequency Range:	1932 - 1992 MHz
<b>Analysis:</b>	The results obtained relate only to the item(s) tested.	
<b>Environmental Test Conditions:</b>	Temperature: 15-35° C	
	Relative Humidity: 30-60%	
	Barometric Pressure: 860-1060 mbar	
<b>Evaluated by:</b>	Manasi Bhandiwad	
<b>Date(s):</b>	February 11, 2011	

**Table 2. EUT Summary Table**

## B. References

<b>CFR 47, Part 15, Subpart B</b>	Electromagnetic Compatibility: Criteria for Radio Frequency Devices
<b>CFR 47, Part 24, Subpart E</b>	Federal Communication Commission, Code of Federal Regulations, Title 47, Part 24: Rules and Regulations for Personal Communications Services
<b>ICES-003, Issue 4 February 2004</b>	Electromagnetic Compatibility: Criteria for Radio Frequency Devices
<b>RSS-133, Issue 5, February 2009</b>	2 GHz Personal Communications Services
<b>ANSI C63.4:2003</b>	Methods and Measurements of Radio-Noise Emissions from Low-Voltage Electrical And Electronic Equipment in the Range of 9 kHz to 40 GHz
<b>ANSI/NCSL Z540-1-1994</b>	Calibration Laboratories and Measuring and Test Equipment - General Requirements
<b>ANSI/ISO/IEC 17025:2000</b>	General Requirements for the Competence of Testing and Calibration Laboratories
<b>EIA/TIA-603-A-2001</b>	Land Mobile FM or PM Communication Equipment Measurement and Performance Standards

**Table 3. Standard References**

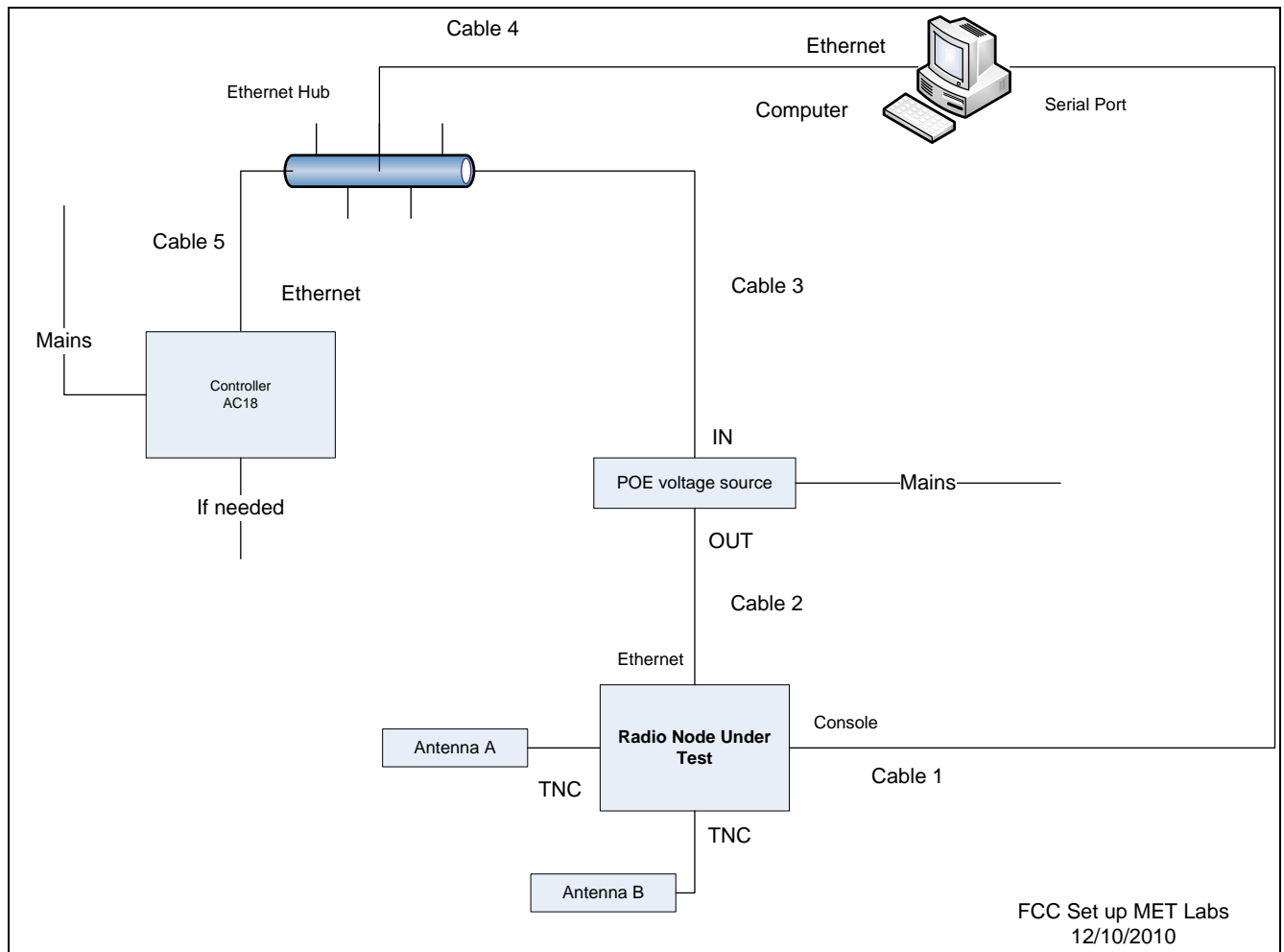
## C. Test Site

All testing was performed at MET Laboratories, Inc., 914 West Patapsco Ave, Baltimore, MD 21230. All equipment used in making physical determinations is accurate and bears recent traceability to the National Institute of Standards and Technology.

Radiated Emissions measurements were performed in a 3 meter semi-anechoic chamber (equivalent to an Open Area Test Site).

## D. Description of Test Sample

The SCRN800 is a UMTS indoor base station to provide 3G voice and data service with 20 dBm RF output power.



**Figure 1. Block Diagram of Test Configuration**

### E. Equipment Configuration

Ref. ID	Name / Description	Model Number	Serial Number
B4 #1	SCRN 800 Band 4	SCRN 800	00481
B4 #2	SCRN 800 Band 4	SCRN 800	00492
B2 #1	SCRN 800 Band 2	SCRN800	00562
B2 #2	SCRN 800 Band 2	SCRN 800	00555
ONLY 1 of each band is for test 2 <sup>nd</sup> unit for backup			

**Table 4. Equipment Configuration**

### F. Support Equipment

Ref. ID	Name / Description	Manufacturer	Model Number	Serial Number
1	Controller	Spider Cloud	SCSN8000	AC18-30660019
2	Computer	Dell	DCTR	6XQFTK1
3	Power Supply	Instek	GPR6030D	NA
4	50 foot Ethernet cable	unknown	NA	NA
5	Short Ethernet cable with power mod	unknown	NA	NA
6	2 ea Power over Ethernet supplies	Phihong	POE36U-1AT-R	NA
7	8 antennas	Laird	MAF94307	NA
8	Green Ethernet 3 foot cord	unknown	NA	NA
9	Power cord SCSN8000 115 VAC	unknown	NA	NA
10	Monitor	HannsG	HSG1027	62-050000079g021 gm2
11	Keyboard	Dell	L30U	NA
12	Mouse	Agilent	unknown	HC6110G0033
13	Switch	Netgear	GS116	1MN1871500442
14	Power supply (wall wart)	Netgear	DSA-20P-10	NA

**Table 5. Support Equipment**



## G. Ports and Cabling Information

Ref. ID	Port name on EUT	Cable Description or reason for no cable	Qty.	Length (m)	Shielded? (Y/N)	Termination Box ID & Port ID
1	Console	RN to Computer	1	16	N	Serial Port
2	Ethernet	RN to POE Source	1	16	N	OUT
3	NA	Hub to POE in	1	1	N	IN
4	Control	Computer to Hub	1	2	N	Hub control
5	NA	Hub to AC18 controller	1	3	N	Not labeled

**Table 6. Ports and Cabling Information**

## H. Mode of Operation

The Band II unit receives WCDMA on 1850 to 1910 MHz and transmits WCDMA Downlink on 1930 to 1995 MHz. It is also capable of receiving GSM 850 on 869 to 894 MHz and GSM 1900 on 1930 to 1990 MHz. It is also capable of receiving its Downlink frequency. Its modes of operation is controlled by connecting a laptop and a SCRN8000 by 2 Ethernet connectors on the unit.

The Band IV unit receives WCDMA on 1710 to 1755 MHz and transmits WCDMA Downlink on 2110 to 2155 MHz. It is also capable of receiving GSM 850 on 869 to 894 MHz and GSM 1900 on 1930 to 1990 MHz. Its modes of operation is controlled by connecting a laptop and a SCRN8000 by 2 Ethernet connectors on the unit. There are 2 duplicate radios in each SCRN800 called A Channel and B Channel. The only difference is the B channel does not have the down link receive capability.

## I. Modifications

### a) Modifications to EUT

No modifications were made to the EUT.

### b) Modifications to Test Standard

No modifications were made to the test standard.

## J. Disposition of EUT

The test sample including all support equipment submitted to the Electro-Magnetic Compatibility Lab for testing was returned to Spider Cloud Wireless upon completion of testing.

### **III. Electromagnetic Compatibility Criteria for Unintentional Radiators**

## Electromagnetic Compatibility Criteria

### § 15.107 Conducted Emissions Limits

**Test Requirement(s):** **15.107 (a)** Except for Class A digital devices, for equipment that is designed to be connected to the public utility (AC) power line, the radio frequency voltage that is conducted back onto the AC power line on any frequency or frequencies within the band 150 kHz to 30 MHz shall not exceed the limits in Table 7. Compliance with this provision shall be based on the measurement of the radio frequency voltage between each power line and ground at the power terminals.

**15.107 (b)** For a Class A digital device that is designed to be connected to the public utility (AC) power line, the radio frequency voltage that is conducted back onto the AC power line on any frequency or frequencies within the band 150 kHz to 30 MHz shall not exceed the limits in Table 7. Compliance with this provision shall be based on the measurement of the radio frequency voltage between each power line and ground at the power terminals. The lower limit applies at the band edges.

**15.207(a)**, Except as shown in paragraphs (b) and (c) of this section\*, charging, AC adapters or battery eliminators the radio frequency voltage that is conducted back onto the AC power line on any frequency or frequencies, within the band 150 kHz to 30 MHz, shall not exceed the limits in the Table 7, as measured using a 50  $\mu$ H/50 ohms line impedance stabilization network (LISN). Compliance with the provisions of this paragraph shall be based on the measurement of the radio frequency voltage between each power line and ground at the power terminal. The lower limit applies at the boundary between the frequencies ranges.

Frequency range (MHz)	Class A Conducted Limits (dB $\mu$ V)		*Class B Conducted Limits (dB $\mu$ V)	
	Quasi-Peak	Average	Quasi-Peak	Average
* 0.15- 0.45	79	66	66 - 56	56 - 46
0.45 - 0.5	79	66	56	46
0.5 - 30	73	60	60	50

Note 1 — The lower limit shall apply at the transition frequencies.  
 Note 2 — The limit decreases linearly with the logarithm if the frequency in the range 0.15 MHz to 0.5 MHz.  
 \* -- Limits per Subsection 15.207(a).

**Table 7. Conducted Limits for Radio Frequency Devices calculated from FCC Part 15 Subsections 15.107(a) (b) and 15.207(a)**

**Test Results:** The EUT was compliant with the Class A requirement(s) of this section. Measured emissions were below applicable limits.

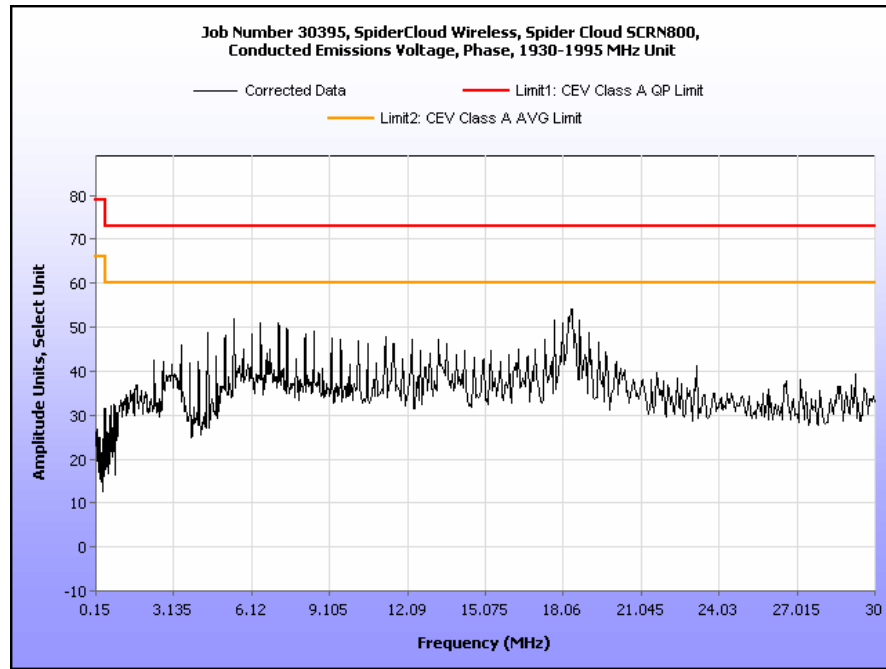
**Test Engineer(s):** Manasi Bhandiwad

**Test Date(s):** 12/14/10

**Conducted Emissions - Voltage, AC Power, Phase Line (120 VAC, 60 Hz)**

Frequency (MHz)	Uncorrected Meter Reading (dBuV) QP	Cable Loss (dB)	Corrected Measurement (dBuV) QP	Limit (dBuV) QP	Margin (dB) QP	Uncorrected Meter Reading (dBuV) Avg.	Cable Loss (dB)	Corrected Measurement (dBuV) AVG	Limit (dBuV) AVG	Margin (dB) AVG
0.185	22.5	0	22.5	79	-56.5	19.05	0	19.05	66	-46.95
0.492	29.65	0	29.65	79	-49.35	23.32	0	23.32	66	-42.68
0.864	29.7	0	29.7	73	-43.3	20.41	0	20.41	60	-39.59
4.42	46.66	0.04	46.7	73	-26.3	43.43	0.04	43.47	60	-16.53
5.42	28.4	0.08	28.48	73	-44.52	20.76	0.08	20.84	60	-39.16
18.35	34.6	0.1	34.7	73	-38.3	27.76	0.1	27.86	60	-32.14

**Table 8. Conducted Emissions - Voltage, AC Power, Phase Line (120 VAC, 60 Hz)**

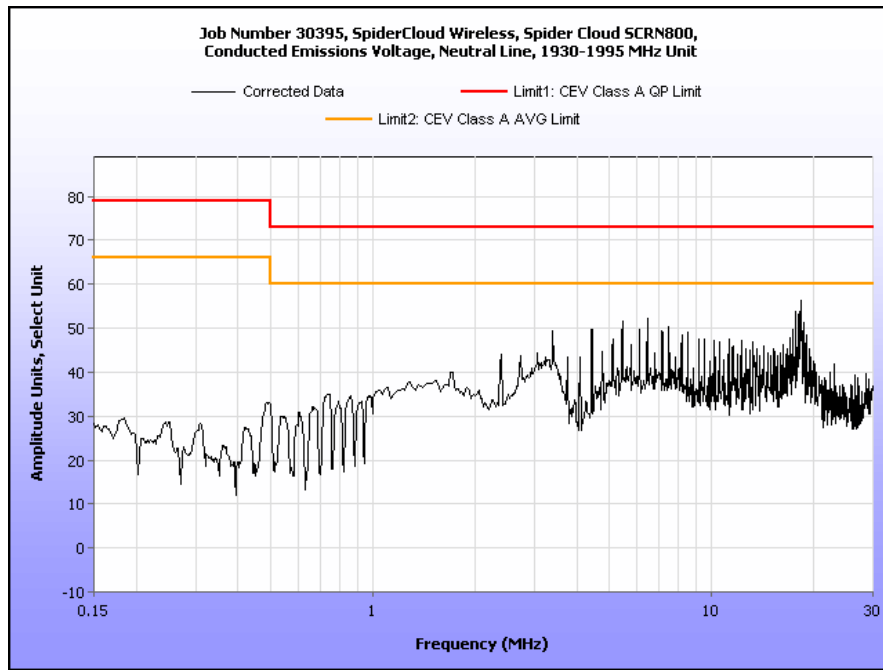


**Plot 1. Conducted Emission, Phase Line Plot**

**Conducted Emissions - Voltage, AC Power, Neutral Line (120 VAC, 60 Hz)**

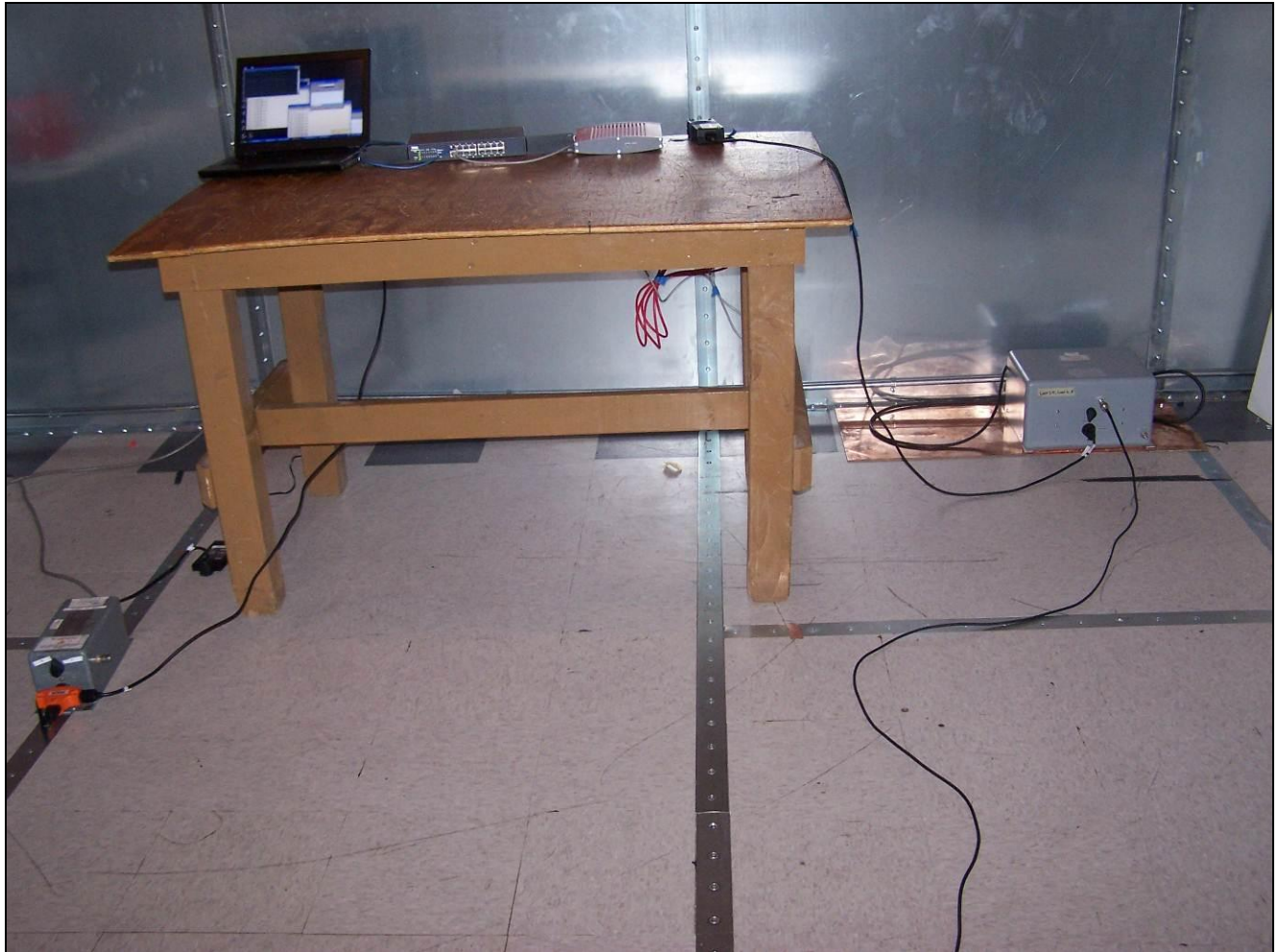
Frequency (MHz)	Uncorrected Meter Reading (dBuV) QP	Cable Loss (dB)	Corrected Measurement (dBuV) QP	Limit (dBuV) QP	Margin (dB) QP	Uncorrected Meter Reading (dBuV) Avg.	Cable Loss (dB)	Corrected Measurement (dBuV) AVG	Limit (dBuV) AVG	Margin (dB) AVG
0.183	26.81	0	26.81	79	-52.19	23.19	0	23.19	66	-42.81
0.494	31.66	0	31.66	79	-47.34	29.18	0	29.18	66	-36.82
0.744	31.68	0	31.68	73	-41.32	25.62	0	25.62	60	-34.38
4.415	41.16	0.04	41.2	73	-31.8	39.78	0.04	39.82	60	-20.18
6.45	35	0.06	35.06	73	-37.94	31.58	0.06	31.64	60	-28.36
18.35	37.73	0.1	37.83	73	-35.17	33.14	0.1	33.24	60	-26.76

**Table 9. Conducted Emissions - Voltage, AC Power, Neutral Line (120 VAC, 60 Hz)**



**Plot 2. Conducted Emission, Neutral Line Plot**

## Conducted Emission Limits Test Setup



**Photograph 1. Conducted Emissions, Test Setup**

## Radiated Emission Limits

### § 15.109 Radiated Emissions Limits

**Test Requirement(s):** **15.109 (a)** Except for Class A digital devices, the field strength of radiated emissions from unintentional radiators at a distance of 3 meters shall not exceed the Class B limits expressed in Table 10.

**15.109 (b)** The field strength of radiated emissions from a Class A digital device, as determined at a distance of 10 meters, shall not exceed the Class A limits expressed in Table 10.

Frequency (MHz)	Field Strength (dB $\mu$ V/m)	
	§15.109 (b), Class A Limit (dB $\mu$ V) @ 10m	§15.109 (a), Class B Limit (dB $\mu$ V) @ 3m
30 - 88	39.00	40.00
88 - 216	43.50	43.50
216 - 960	46.40	46.00
Above 960	49.50	54.00

**Table 10. Radiated Emissions Limits calculated from FCC Part 15, §15.109 (a) (b)**

**Test Procedures:** The EUT was placed on a non-metallic table, 80 cm above the ground plane inside a semi-anechoic chamber. The method of testing and test conditions of ANSI C63.4 were used. An antenna was located 3 m from the EUT on an adjustable mast. A pre-scan was first performed in order to find prominent radiated emissions. For final emissions measurements at each frequency of interest, the EUT was rotated and the antenna height was varied between 1 m and 4 m in order to maximize the emission. Measurements in both horizontal and vertical polarities were made and the data was recorded. Unless otherwise specified, measurements were made using a quasi-peak detector with a 120 kHz bandwidth.

**Test Results:** The EUT was compliant with the Class A requirement(s) of this section. Measured emissions were below applicable limits.

**Test Engineer(s):** Len Knight

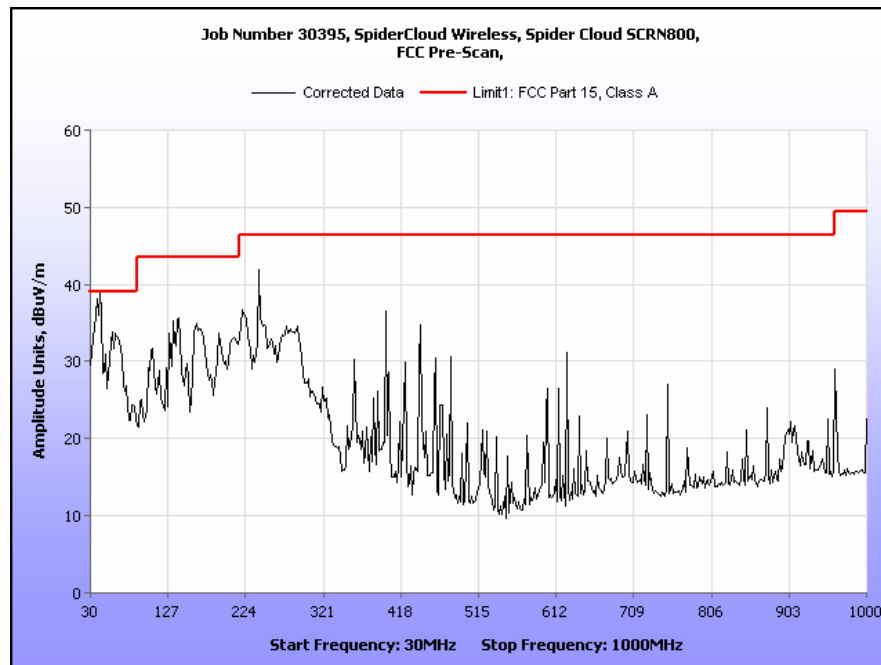
**Test Date(s):** 12/14/10

### Radiated Emissions Limits Test Results, Class A

Frequency (MHz)	EUT Azimuth (Degrees)	Antenna Polarity (H/V)	Antenna HEIGHT (m)	Uncorrected Amplitude (dBuV)	Antenna Correction Factor (dB) (+)	Cable Loss (dB) (+)	Distance Correction Factor (dB) (-)	Corrected Amplitude (dBuV/m)	Limit (dBuV/m)	Margin (dB)
42.344689	265	H	3.25	14.59	12.46	0.23	10.46	16.82	39.00	-22.18
42.344689	353	V	1.00	33.47	12.46	0.23	10.46	35.70	39.00	-3.30
62.925852	245	H	1.90	21.62	7.60	0.23	10.46	18.99	39.00	-20.01
62.925852	352	V	1.00	33.81	7.60	0.23	10.46	31.18	39.00	-7.82
90.180361	88	H	3.54	27.01	7.84	0.23	10.46	24.62	43.50	-18.88
90.180361	363	V	1.03	26.75	7.84	0.23	10.46	24.36	43.50	-19.14
56.112224	252	H	1.87	18.55	7.41	0.23	10.46	15.73	39.00	-23.27
56.112224	302	V	1.01	33.73	7.41	0.23	10.46	30.91	39.00	-8.09
134.3857	91	H	1.66	28.37	13.50	0.23	10.46	31.64	43.50	-11.86
134.3857	50	V	1.02	28.65	13.50	0.23	10.46	31.92	43.50	-11.58
172.78257	77	H	1.27	31.07	11.72	0.23	10.46	32.56	43.50	-10.94
172.78257	345	V	1.01	26.65	11.72	0.23	10.46	28.14	43.50	-15.36
239.99499	99	H	1.34	40.65	12.10	0.39	10.46	42.68	46.40	-3.72
239.99499	197	V	1.94	32.34	12.10	0.39	10.46	34.37	46.40	-12.03
399.98297	66	H	2.24	26.38	16.20	0.83	10.46	32.95	46.40	-13.45
399.98297	340	V	1.28	29.68	16.20	0.83	10.46	36.25	46.40	-10.15
422.38377	64	H	2.08	21.48	16.55	0.98	10.46	28.55	46.40	-17.85
422.38377	350	V	1.21	22.39	16.55	0.98	10.46	29.46	46.40	-16.94
43.787575	251	H	2.97	14.56	11.53	0.23	10.46	15.86	39.00	-23.14
43.787575	87	V	1.01	32.28	11.53	0.23	10.46	33.58	39.00	-5.42
42.956914	232	H	2.33	12.80	12.03	0.23	10.46	14.60	39.00	-24.40
42.956914	13	V	1.03	31.98	12.03	0.23	10.46	33.78	39.00	-5.22

**Table 11. Radiated Emissions Limits, Test Results, 30 MHz – 1 GHz, FCC Limits**

Note: The EUT was tested at 3 m.



**Plot 3. Radiated Emissions, 30 MHz - 1 GHz, FCC Limits**

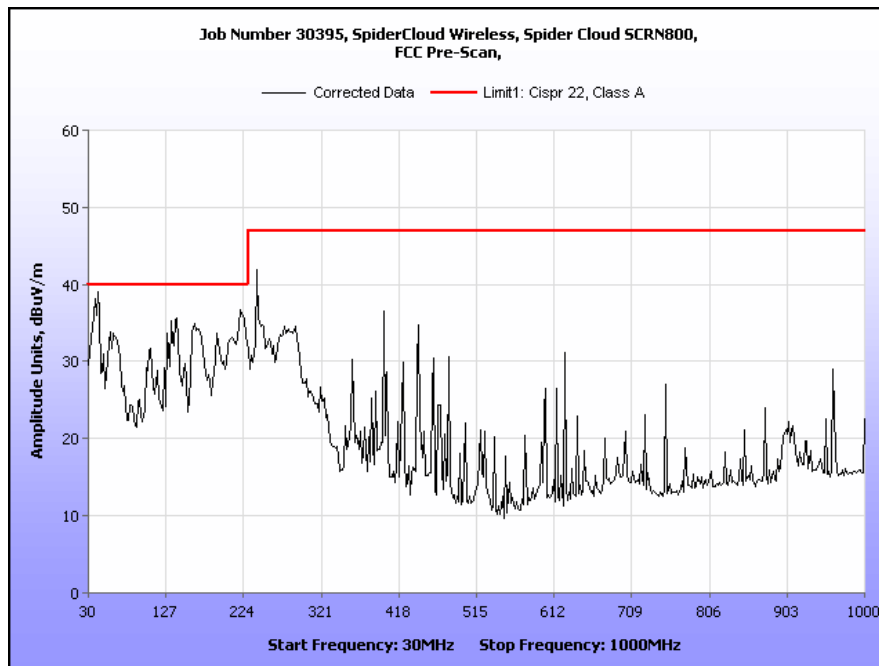


### Radiated Emissions Limits Test Results, Class A

Frequency (MHz)	EUT Azimuth (Degrees)	Antenna Polarity (H/V)	Antenna HEIGHT (m)	Uncorrected Amplitude (dBuV)	Antenna Correction Factor (dB) (+)	Cable Loss (dB) (+)	Distance Correction Factor (dB) (-)	Corrected Amplitude (dBuV/m)	Limit (dBuV/m)	Margin (dB)
42.344689	265	H	3.25	14.59	12.46	0.23	10.46	16.82	40.00	-23.18
42.344689	353	V	1.00	33.47	12.46	0.23	10.46	35.70	40.00	-4.30
62.925852	245	H	1.90	21.62	7.60	0.23	10.46	18.99	40.00	-21.01
62.925852	352	V	1.00	33.81	7.60	0.23	10.46	31.18	40.00	-8.82
90.180361	88	H	3.54	27.01	7.84	0.23	10.46	24.62	40.00	-15.38
90.180361	363	V	1.03	26.75	7.84	0.23	10.46	24.36	40.00	-15.64
56.112224	252	H	1.87	18.55	7.41	0.23	10.46	15.73	40.00	-24.27
56.112224	302	V	1.01	33.73	7.41	0.23	10.46	30.91	40.00	-9.09
134.3857	91	H	1.66	28.37	13.50	0.23	10.46	31.64	40.00	-8.36
134.3857	50	V	1.02	28.65	13.50	0.23	10.46	31.92	40.00	-8.08
172.78257	77	H	1.27	31.07	11.72	0.23	10.46	32.56	40.00	-7.44
172.78257	345	V	1.01	26.65	11.72	0.23	10.46	28.14	40.00	-11.86
239.99499	99	H	1.34	40.65	12.10	0.39	10.46	42.68	47.00	-4.32
239.99499	197	V	1.94	32.34	12.10	0.39	10.46	34.37	47.00	-12.63
399.98297	66	H	2.24	26.38	16.20	0.83	10.46	32.95	47.00	-14.05
399.98297	340	V	1.28	29.68	16.20	0.83	10.46	36.25	47.00	-10.75
422.38377	64	H	2.08	21.48	16.55	0.98	10.46	28.55	47.00	-18.45
422.38377	350	V	1.21	22.39	16.55	0.98	10.46	29.46	47.00	-17.54
43.787575	251	H	2.97	14.56	11.53	0.23	10.46	15.86	40.00	-24.14
43.787575	87	V	1.01	32.28	11.53	0.23	10.46	33.58	40.00	-6.42
42.956914	232	H	2.33	12.80	12.03	0.23	10.46	14.60	40.00	-25.40
42.956914	13	V	1.03	31.98	12.03	0.23	10.46	33.78	40.00	-6.22

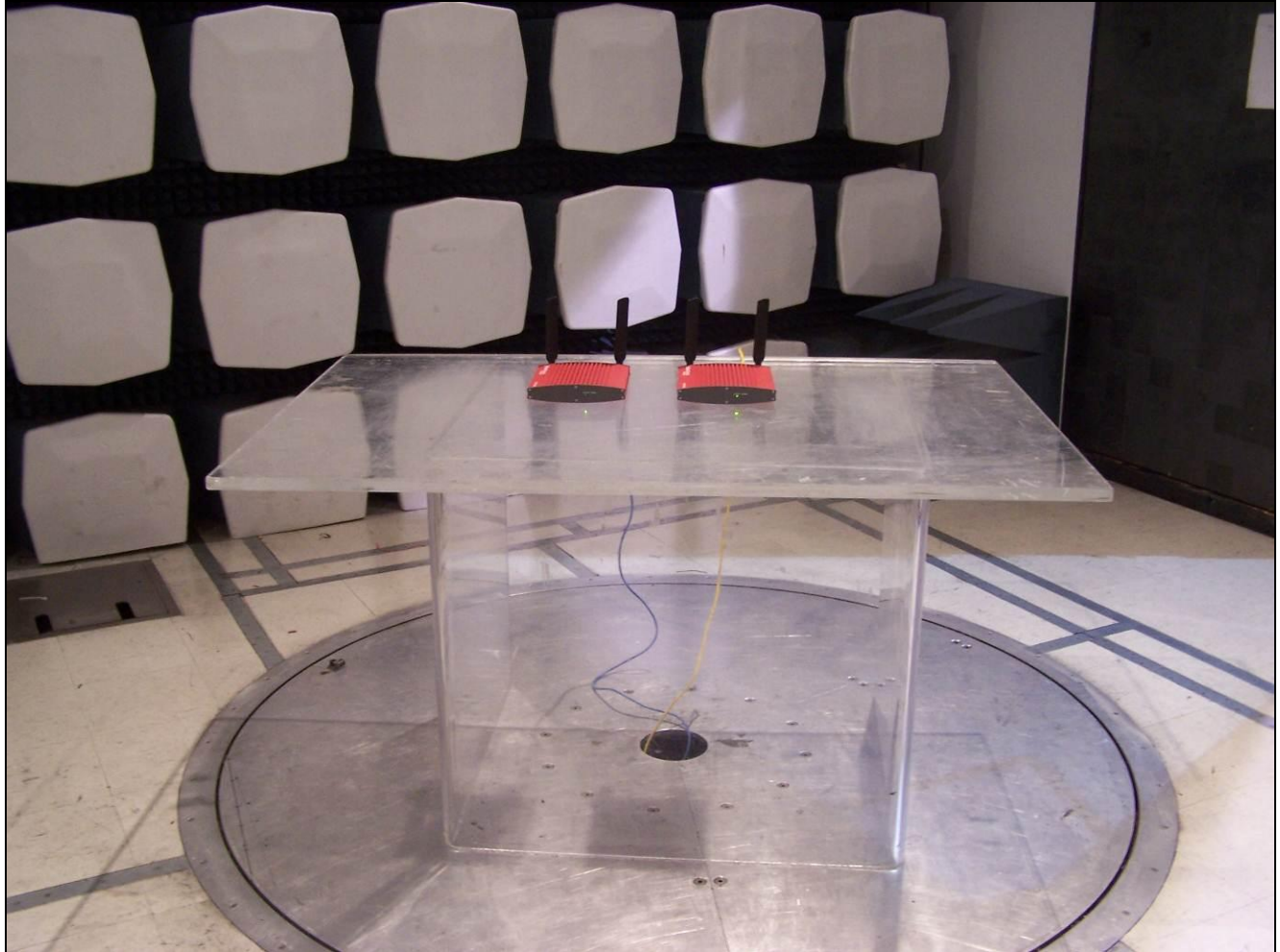
**Table 12. Radiated Emissions Limits, Test Results, ICES-003 Limits**

Note: The EUT was tested at 3 m.



**Plot 4. Radiated Emissions, ICES-003 Limits**

## Radiated Emission Limits Test Setup



**Photograph 2. Radiated Emission, Test Setup**



## **IV. Electromagnetic Compatibility Criteria for Intentional Radiators**

## Electromagnetic Compatibility Criteria for Intentional Radiators

### § 2.1046 RF Power Output

**Test Requirements:** § 2.1046 Measurements required: RF power output:

§ 2.1046 (a) For transmitters other than single sideband, independent sideband and controlled carrier radiotelephone, power output shall be measured at the RF output terminals when the transmitter is adjusted in accordance with the tune-up procedure to give the values of current and voltage on the circuit elements specified in § 2.1033(c)(8). The electrical characteristics of the radio frequency load attached to the output terminals when this test is made shall be stated.

§ 2.1046 (b) For single sideband, independent sideband, and single channel, controlled carrier radiotelephone transmitters, the procedure specified in paragraph (a) of this section shall be employed and, in addition, the transmitter shall be modulated during the test as specified and as applicable in § 2.1046 (b) (1-5). In all tests, the input level of the modulating signal shall be such as to develop rated peak envelope power or carrier power, as appropriate, for the transmitter.

§ 2.1046 (c) For measurements conducted pursuant to paragraphs (a) and (b) of this section, all calculations and methods used by the applicant for determining carrier power or peak envelope power, as appropriate, on the basis of measured power in the radio frequency load attached to the transmitter output terminals shall be shown. Under the test conditions specified, no components of the emission spectrum shall exceed the limits specified in the applicable rule parts as necessary for meeting occupied bandwidth or emission limitations.

#### § 24.232 Power and antenna height limits.

§ 24.232 (b): Mobile/portable stations are limited to 2 watts e.i.r.p. peak power and the equipment must employ means to limit the power to the minimum necessary for successful communications.

#### RSS-133, Section 6.4 Transmitter Output Power

The average equivalent isotropically radiated power (e.i.r.p.) for transmitters shall not exceed the limits given in SRSP-510. Moreover, base station transmitters operating in the band 1930-1995 MHz shall not have output power exceeding 100 watts.

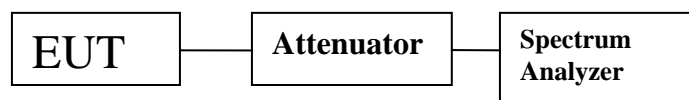
In addition, when the transmitter power is measured in terms of average value, the peak-to-average ratio of the power shall not exceed 13 dB.

**Test Procedures:** As required by 47 CFR 2.1046, RF power output measurements were made at the RF output terminals using an attenuator and spectrum analyzer or power meter. This test was performed in all applicable modulations.

**Test Results:** The EUT complies with the requirements of this section. The EUT conducted power does not exceed limit at the carrier frequency.

**Test Engineer(s):** Manasi Bhandiwad

**Test Date(s):** 12/13/10



Block Diagram 1. RF Power Output Test Setup

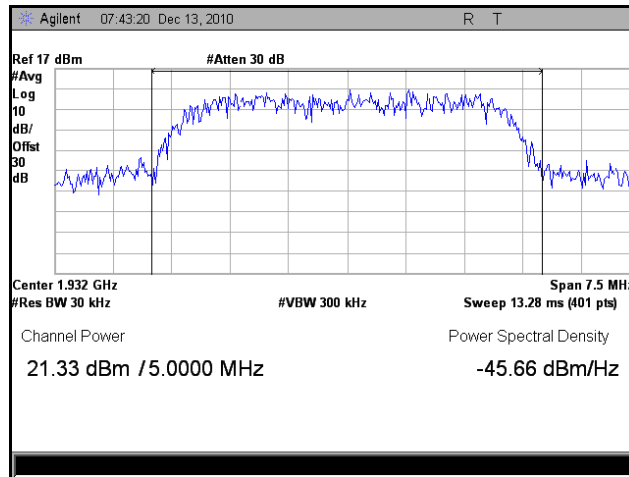


Channel	Average Output Power dBm
Low	21.33
Mid	20.02
High	19.88

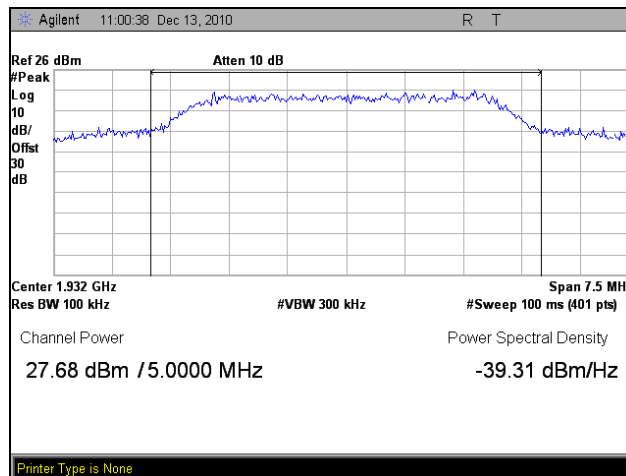
Table 13. RF Output Power, Test Results

Channel	Peak Output Power dBm	Average Output Power dBm	Peak/Average Ratio dB	Limit dB
Low	27.68	21.33	6.35	13
Mid	26.57	20.02	6.55	13
High	26.68	19.88	6.8	13

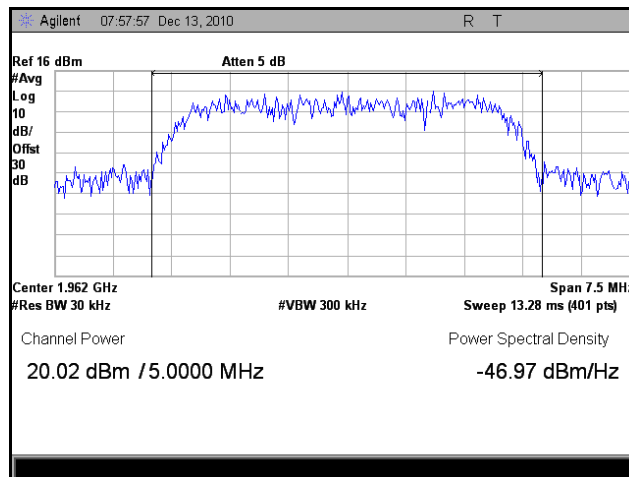
Table 14. Peak/Average Ratio



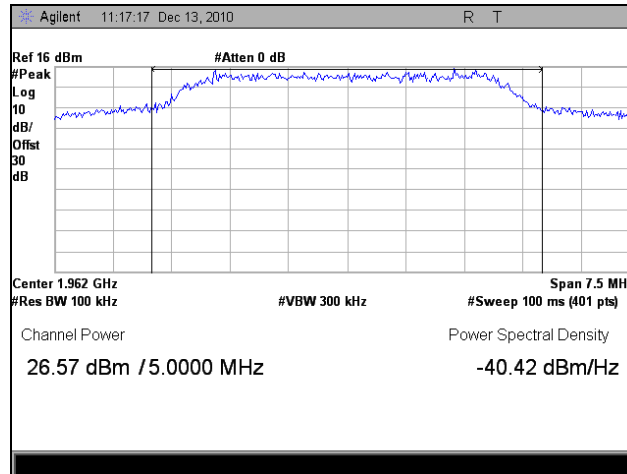
Plot 5. RF Output Power, Low Channel, Average



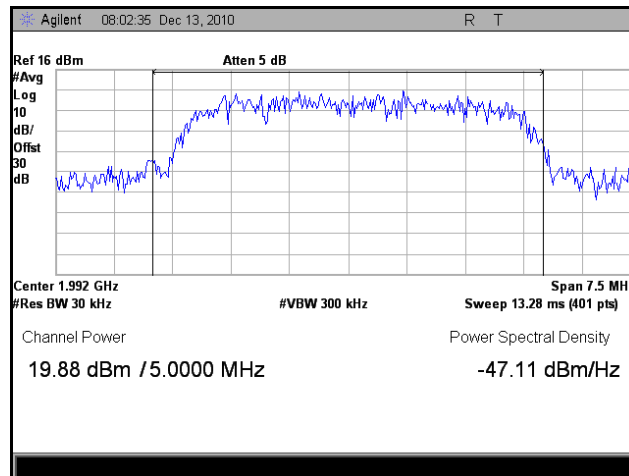
Plot 6. Output Power, Low Channel, Peak



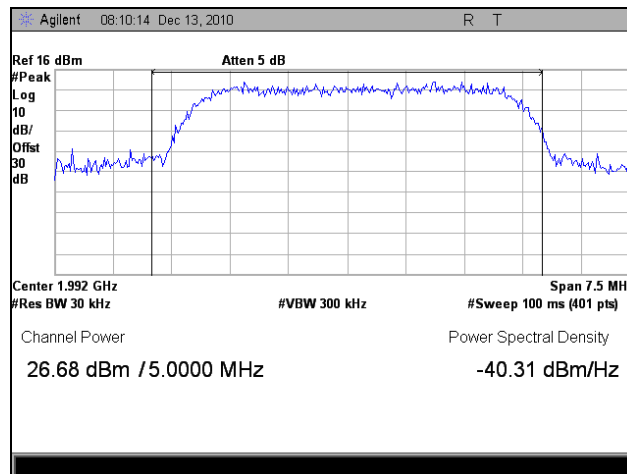
Plot 7. RF Output Power, Mid Channel, Average



**Plot 8. Output Power, Mid Channel, Peak**



**Plot 9. RF Output Power, High Channel, Average**



**Plot 10. Output Power, High Channel, Peak**



## § 2.1049 Occupied Bandwidth

**Test Requirement(s):** § 2.1049 **Measurements required: Occupied bandwidth:** The occupied bandwidth, that is the frequency bandwidth such that, below its lower and above its upper frequency limits, the mean powers radiated are each equal to 0.5 percent of the total mean power radiated by a given emission shall be measured under the specified conditions of § 2.1049 (a) through (i) as applicable.

**Test Procedures:** As required by 47 CFR 2.1049, *occupied bandwidth measurements* were made with a Spectrum Analyzer connected to the RF ports for both Uplink and Downlink

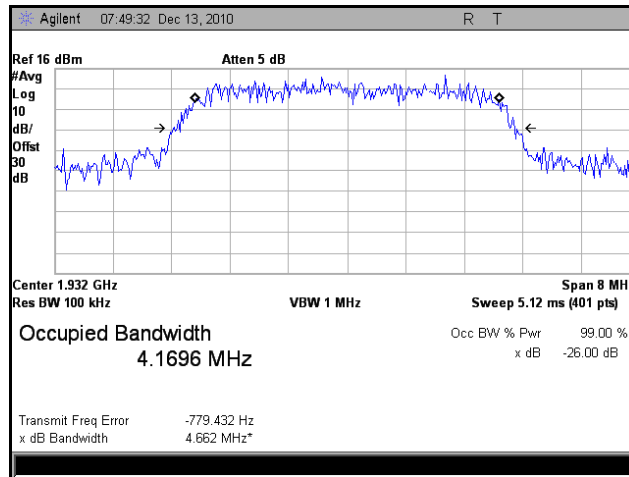
The modulation characteristics of signal generator's carrier was measured first at a maximum RF level prescribed by the OEM. The signal generator was then connected to either the Uplink or Downlink input at the appropriate RF level. The resulting modulated signal through the EUT was measured and compared against the original signal.

**Test Results:** The EUT complies with the requirements of this section.

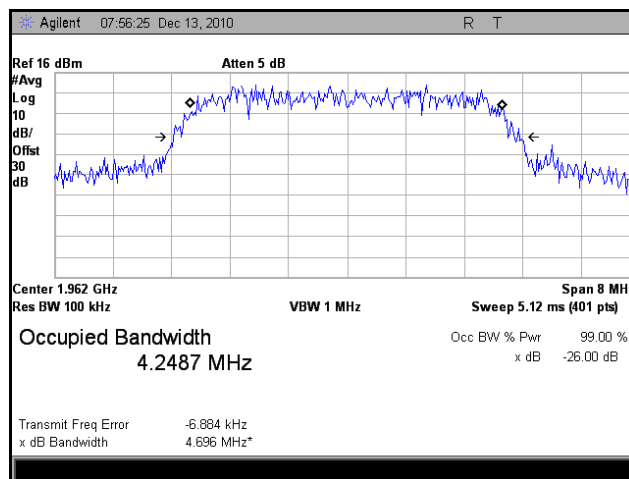
**Test Engineer(s):** Manasi Bhandiwad

**Test Date(s):** 12/13/10

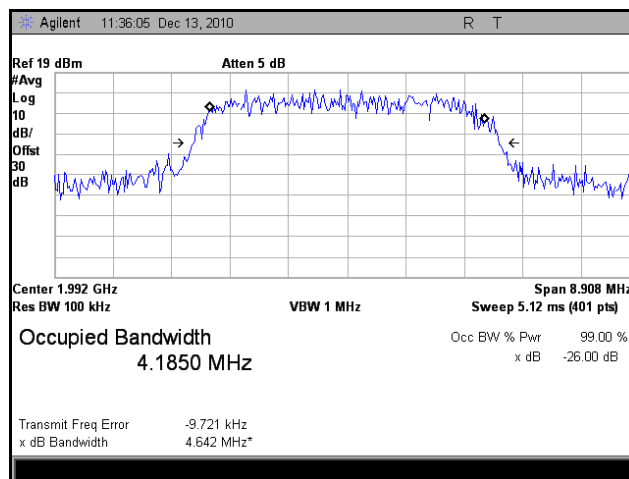




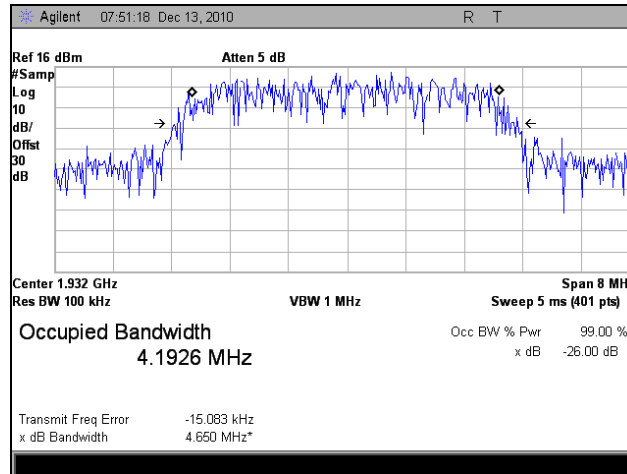
Plot 11. Occupied Bandwidth, Low Channel



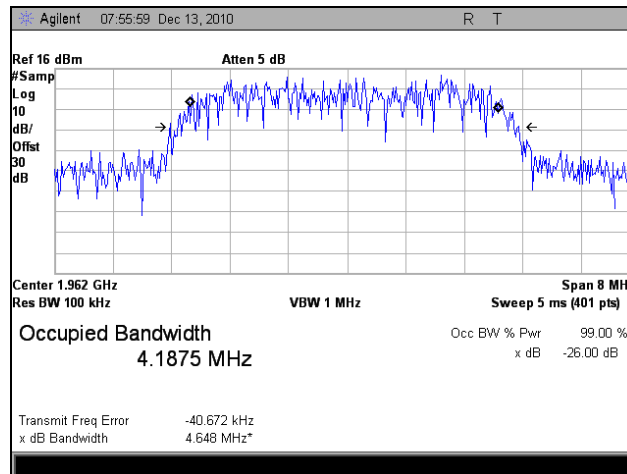
Plot 12. Occupied Bandwidth, Mid Channel



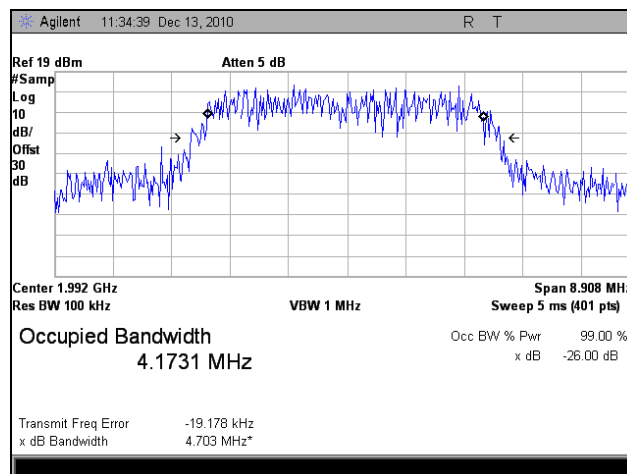
Plot 13. Occupied Bandwidth, High Channel



Plot 14. 99% Occupied Bandwidth, Low Channel



Plot 15. 99% Occupied Bandwidth, Mid Channel



Plot 16. 99% Occupied Bandwidth, High Channel



## Electromagnetic Compatibility Criteria for Intentional Radiators

### § 2.1051 Spurious Emissions at Antenna Terminals

**Test Requirement(s):** § 2.1051 **Measurements required: Spurious emissions at antenna terminals:** The radio frequency voltage or powers generated within the equipment and appearing on a spurious frequency shall be checked at the equipment output terminals when properly loaded with a suitable artificial antenna. Curves or equivalent data shall show the magnitude of each harmonic and other spurious emission that can be detected when the equipment is operated under the conditions specified in § 2.1049 as appropriate. The magnitude of spurious emissions which are attenuated more than 20 dB below the permissible value need not be specified.

**§24.238 Emission limitations for Broadband PCS equipment:** The rules in this section govern the spectral characteristics of emissions in the Broadband Personal Communications Service.

**§ 24.238 (a)** Out of band emissions. The power of any emission outside of the authorized operating frequency ranges must be attenuated below the transmitting power (P) by a factor of at least  $43 + 10 \log(P)$  dB.

**Test Procedures:**

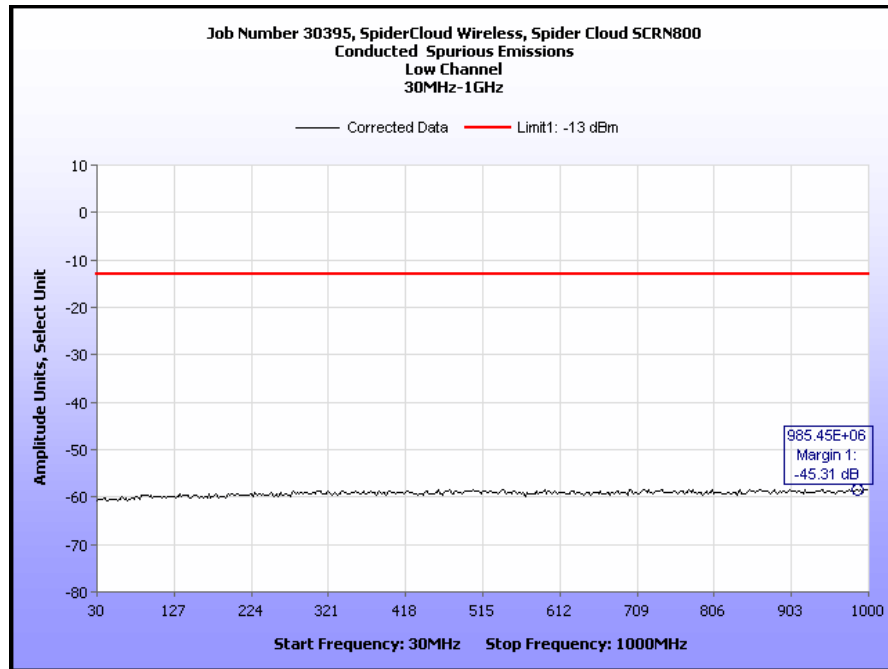
A modulated carrier generated by the signal generator carrier was connected to either the Uplink or Downlink RF port at a maximum level as determined by the OEM. A spectrum analyzer was connected to either the Uplink or Downlink port depending on the circuitry being measured. The spectrum analyzer was set to 100 kHz RBW and 300 kHz VBW for testing below 1 GHz, and it was set to 1 MHz RBW and 3 MHz RBW for testing above 1 GHz.

The inter-modulation requirements were performed in a similar manner as described above. The spectrum analyzer was set to 100KHz RBW and 300KHz VBW. Two modulated carriers were injected into the EUT. The in band spurious emissions were investigated. The filter response was also measured for the DL and UL.

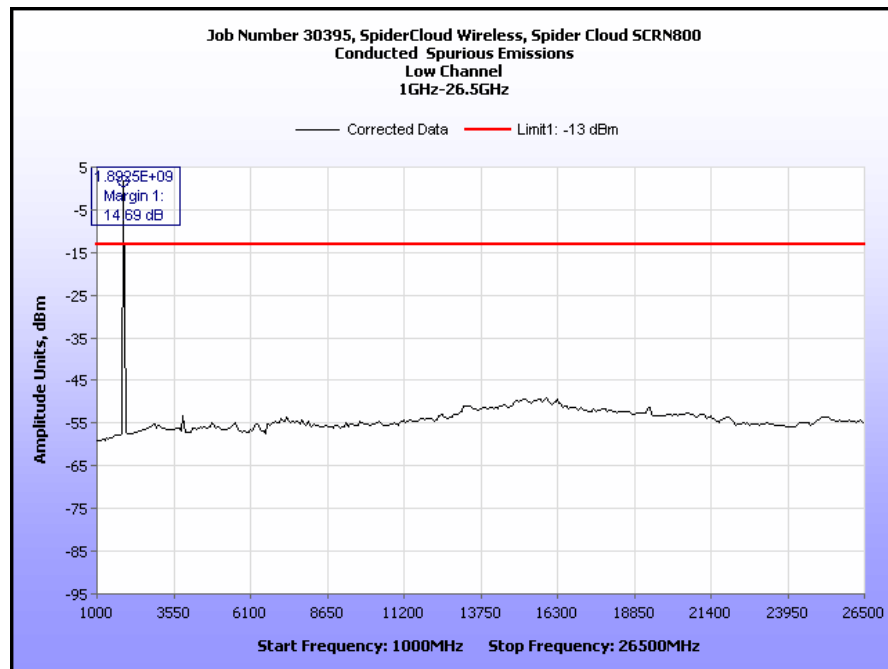
**Test Results:** The EUT complies with the requirements of this section. There were no detectable spurious emissions for this EUT.

**Test Engineer(s):** Manasi Bhandiwad

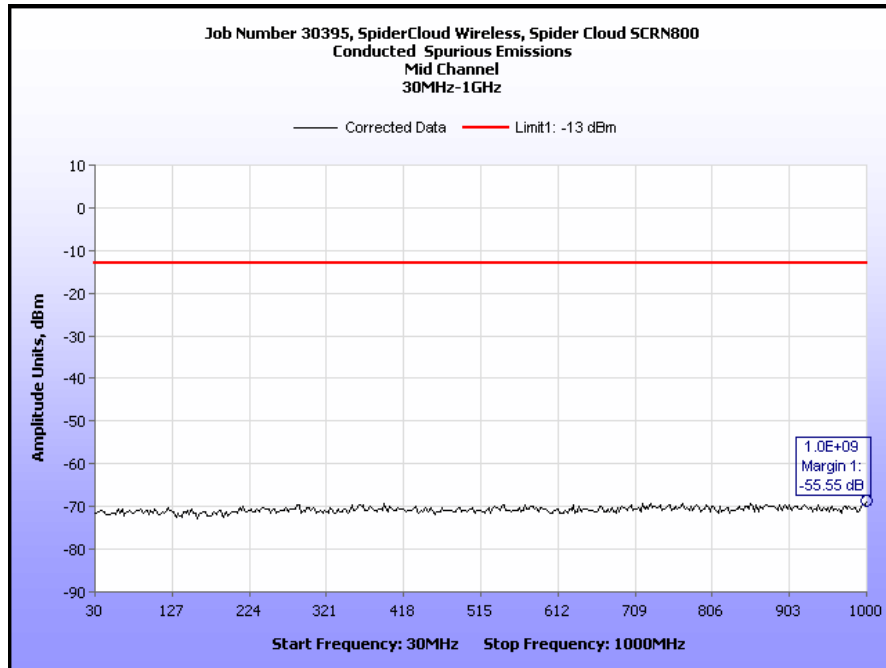
**Test Date(s):** 12/13/10



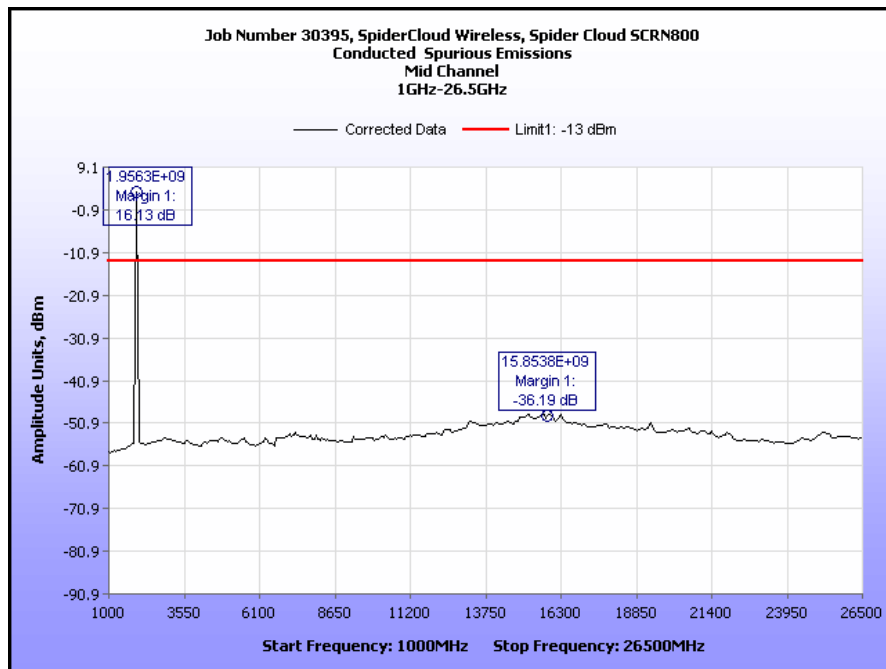
Plot 17. Spurious Emissions at Antenna Terminal, Low Channel, 30 MHz – 1 GHz



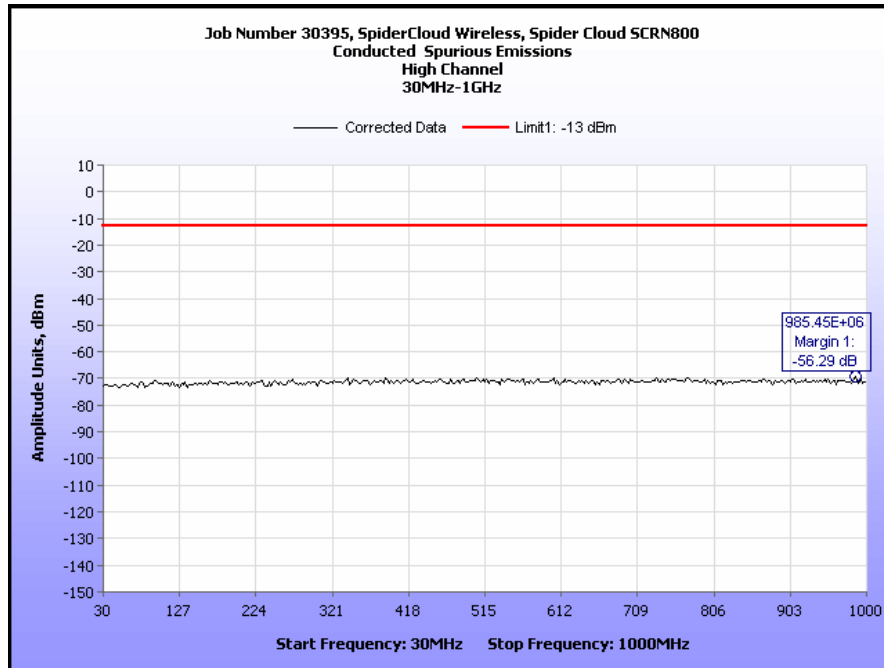
Plot 18. Spurious Emissions at Antenna Terminal, Low Channel, 1 GHz – 26.5 GHz



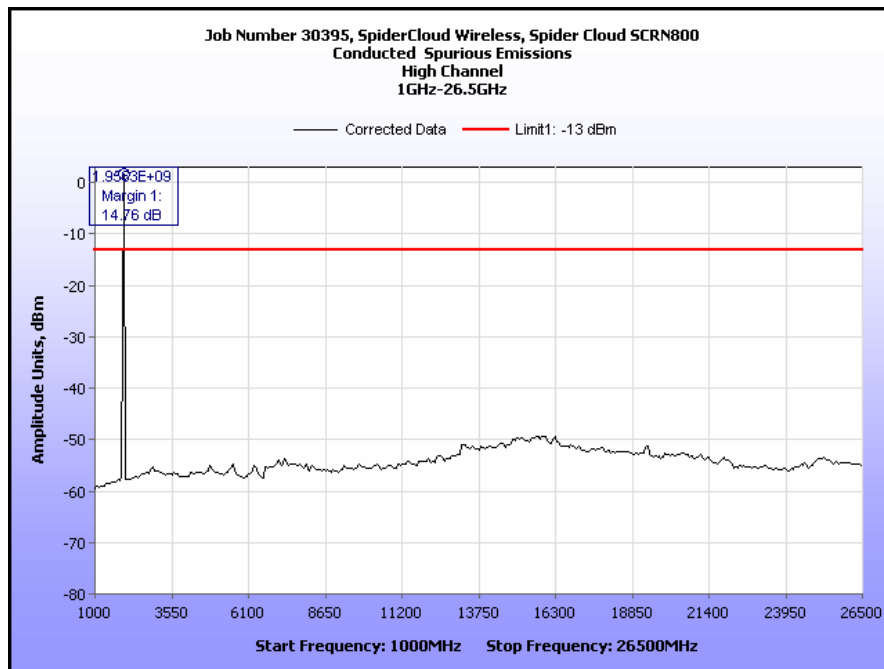
Plot 19. Spurious Emissions at Antenna Terminal, Mid Channel, 30 MHz – 1 GHz



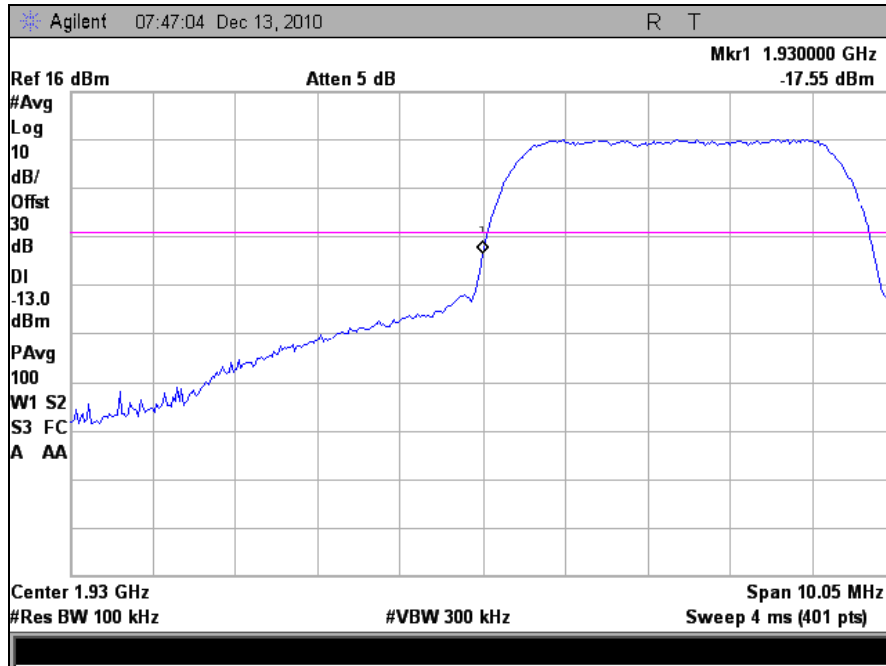
Plot 20. Spurious Emissions at Antenna Terminal, Mid Channel, 1 GHz – 26.5 GHz



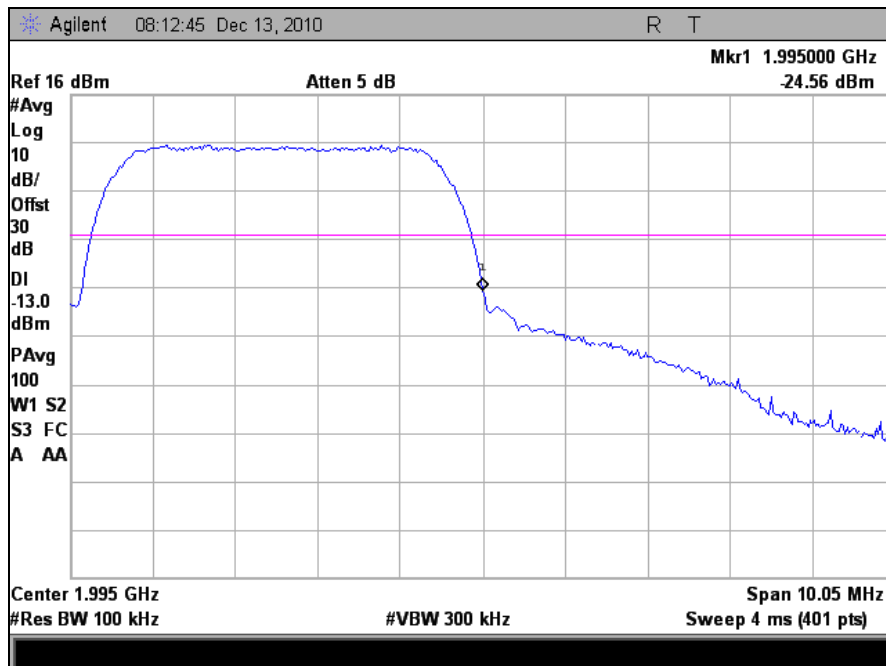
Plot 21. Spurious Emissions at Antenna Terminal, High Channel, 30 MHz – 1 GHz



Plot 22. Spurious Emissions at Antenna Terminal, High Channel, 1 GHz – 26.5 GHz



Plot 23. Band Edge, Low Channel



Plot 24. Band Edge, High Channel

## Electromagnetic Compatibility Criteria for Intentional Radiators

### § 2.1053 Radiated Spurious Emissions

**Test Requirement(s):** § 2.1053 Measurements required: Field strength of spurious radiation.

§ 2.1053 (a) Measurements shall be made to detect spurious emissions that may be radiated directly from the cabinet, control circuits, power leads, or intermediate circuit elements under normal conditions of installation and operation. Curves or equivalent data shall be supplied showing the magnitude of each harmonic and other spurious emission. For this test, single sideband, independent sideband, and controlled carrier transmitters shall be modulated under the conditions specified in paragraph (c) of § 2.1049, as appropriate. For equipment operating on frequencies below 890 MHz, an open field test is normally required with the measuring instrument antenna located in the far-field at all test frequencies. In the event it is either impractical or impossible to make open field measurements (e.g. a broadcast transmitter installed in a building) measurements will be accepted of the equipment as installed. Such measurements must be accompanied by a description of the site where the measurements were made showing the location of any possible source of reflections which might distort the field strength measurements. Information submitted shall include the relative radiated power of each spurious emission with reference to the rated power output of the transmitter, assuming all emissions are radiated from half-wave dipole antennas.

§ 2.1053 (b): The measurements specified in paragraph (a) of this section shall be made for the following equipment:

- (1) Those in which the spurious emissions are required to be 60 dB or more below the mean power of the transmitter.
- (2) All equipment operating on frequencies higher than 25 MHz.
- (3) All equipment where the antenna is an integral part of, and attached directly to the transmitter.
- (4) Other types of equipment as required, when deemed necessary by the Commission.

§ 24.238 **Emission limitations for Broadband PCS equipment:** The rules in this section govern the spectral characteristics of emissions in the Cellular Radiotelephone Service.

§ 24.238 (a): Out of band emissions. The power of any emission outside of the authorized operating frequency ranges must be attenuated below the transmitting power (P) by a factor of at least  $43 + 10 \log(P)$ .





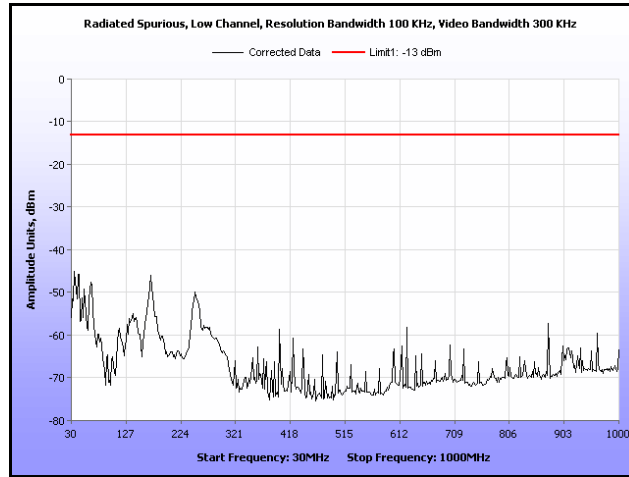
**Test Procedures:** As required by 47 CFR 2.1053, the *field strengths of radiated spurious emissions* were made in accordance with the procedures of TIA/EIA-603-A-2001 "Land Mobile FM or PM Communications Equipment Measurement and Performance Standards".

Radiated emission measurements were performed inside a 3 meter semi-anechoic chamber (equivalent to an Open Area Test Site). The distance between the EUT and the test antenna was 3 meters for below 1 GHz and 1m for frequencies above 1 GHz. The EUT's RF port was connected to a dummy load. The intensities of the radiated emissions were maximized by rotating the turntable 360 degrees and varying the receive antenna from 1 to 4m. Measurements were made with the receive antenna in both horizontal and vertical polarizations.

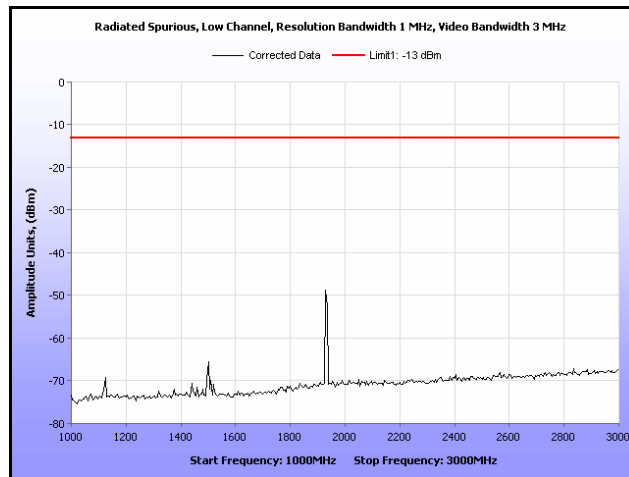
**Test Results:** The EUT complies with the requirements of this section.

**Test Engineer:** Manasi Bhandiwad

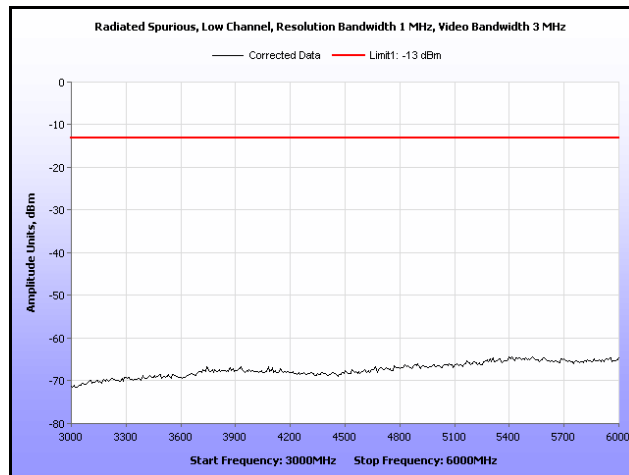
**Test Date(s):** 12/14/10 - 12/15/10



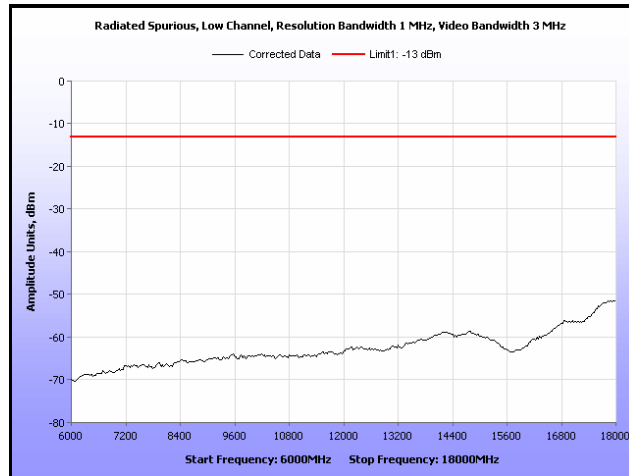
Plot 25. Radiated Spurious Emissions, Low Channel, 30 MHz – 1 GHz



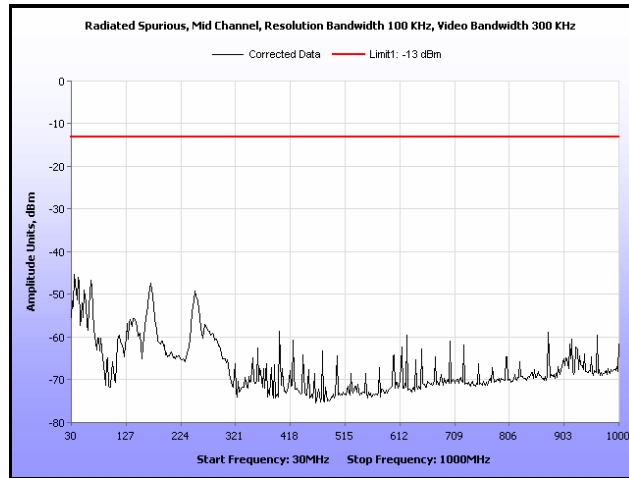
Plot 26. Radiated Spurious Emissions, Low Channel, 1 GHz – 3 GHz



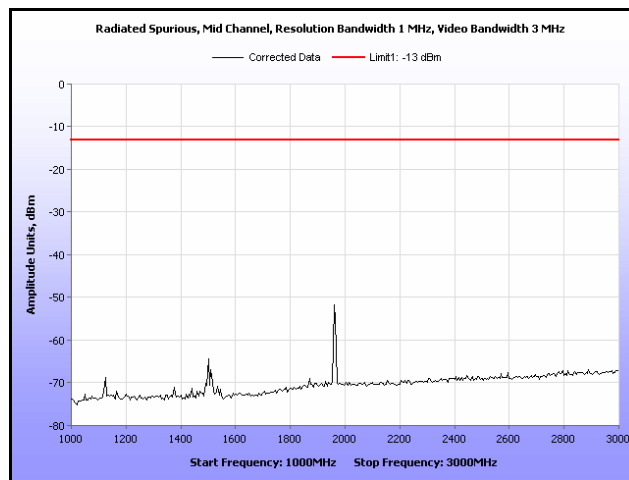
Plot 27. Radiated Spurious Emissions, Low Channel, 3 GHz – 6 GHz



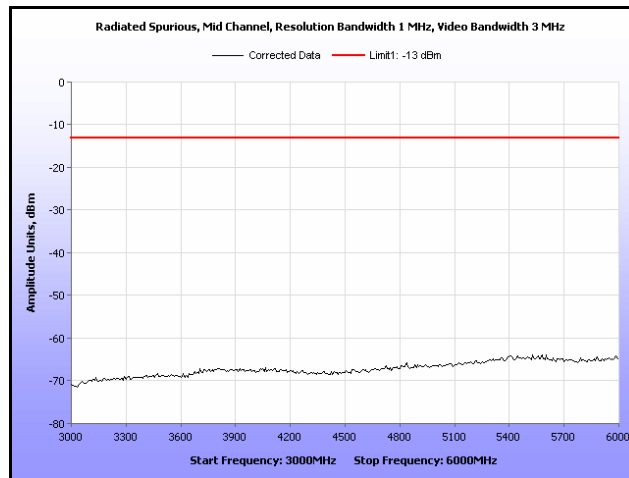
**Plot 28. Radiated Spurious Emissions, Low Channel, 6 GHz – 18 GHz**



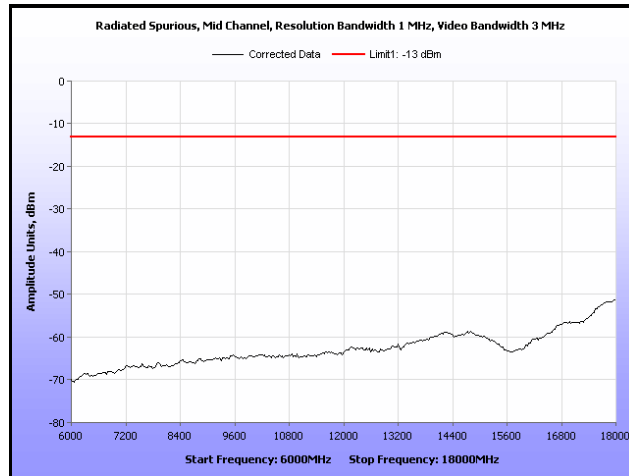
Plot 29. Radiated Spurious Emissions, Mid Channel, 30 MHz – 1 GHz



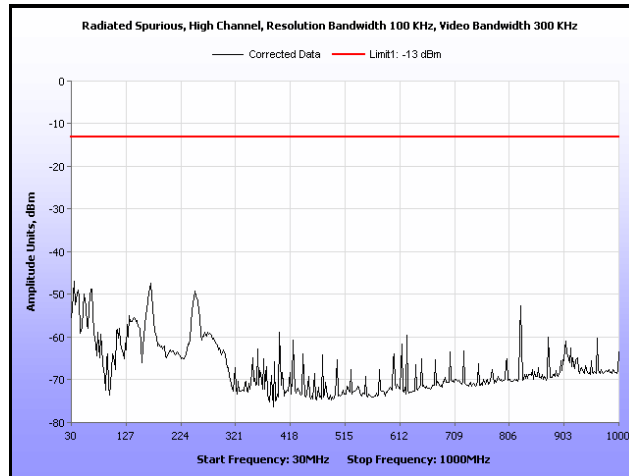
Plot 30. Radiated Spurious Emissions, Mid Channel, 1 GHz – 3 GHz



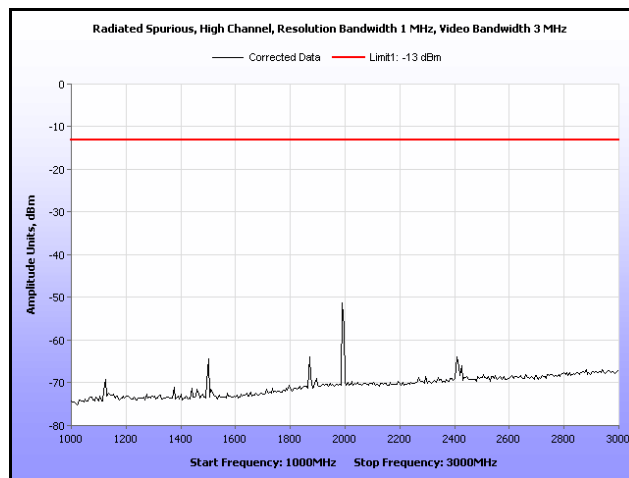
Plot 31. Radiated Spurious Emissions, Mid Channel, 3 GHz – 6 GHz



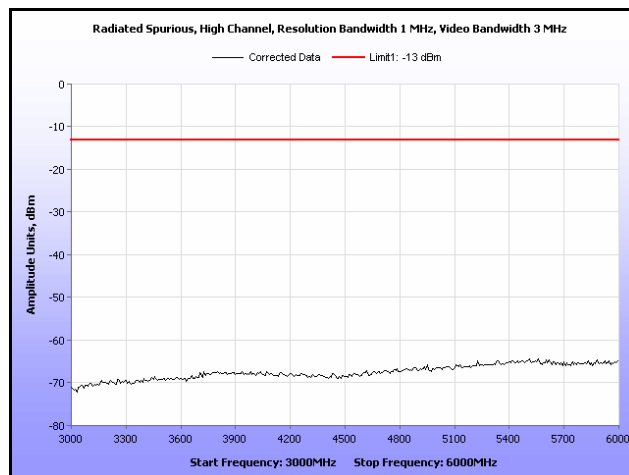
**Plot 32. Radiated Spurious Emissions, Mid Channel, 6 GHz – 18 GHz**



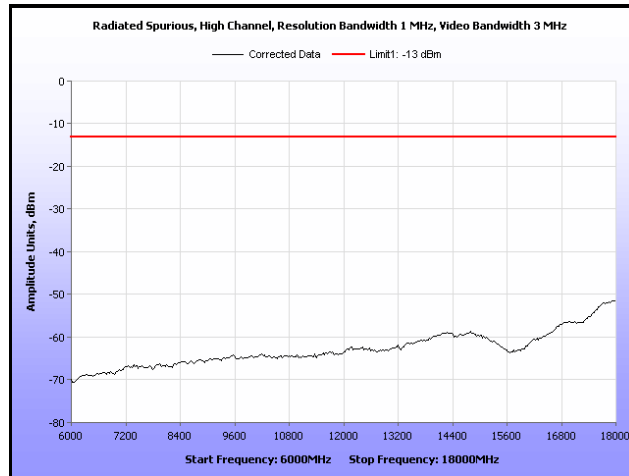
Plot 33. Radiated Spurious Emissions, High Channel, 30 MHz – 1 GHz



Plot 34. Radiated Spurious Emissions, High Channel, 1 GHz – 3 GHz

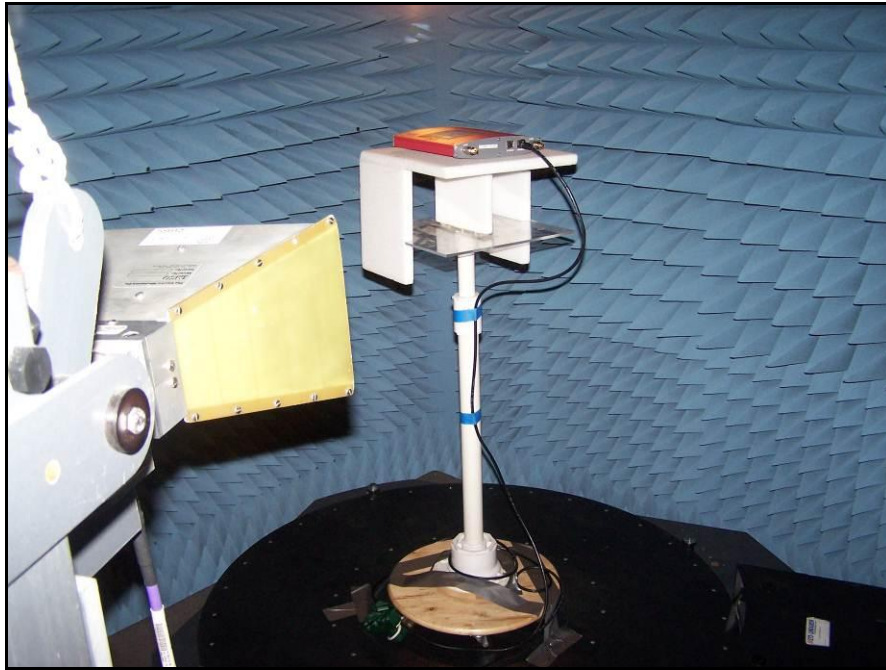


Plot 35. Radiated Spurious Emissions, High Channel, 3 GHz – 6 GHz



**Plot 36. Radiated Spurious Emissions, High Channel, 6 GHz – 18 GHz**

## Electromagnetic Compatibility Criteria for Intentional Radiators



**Photograph 3. Radiated Emissions, Test Setup 1**



**Photograph 4. Radiated Emissions, Test Setup 2**



## Electromagnetic Compatibility Criteria for Intentional Radiators

### RSS-GEN Receiver Spurious Emissions Requirements

**Test Requirements:** The following receiver spurious emission limits shall be complied with:

- (a) If a radiated measurement is made, all spurious emissions shall comply with the limits of Table 15.

Spurious Frequency (MHz)	Field Strength (microvolt/m at 3 metres)
30 – 88	100
88 – 216	150
216 – 960	200
Above 960	500

**Table 15. Spurious Emission Limits for Receivers**

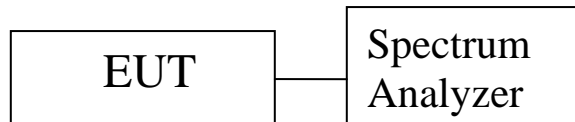
- (b) If a conducted measurement is made, no spurious output signals appearing at the antenna terminals shall exceed 2 nanowatts per any 4 kHz spurious frequency in the band 30-1000 MHz, or 5 nanowatts above 1 GHz.

**Test Procedures:** The EUT was programmed for receive mode only. The EUT was setup inside an anechoic chamber. The resolution bandwidth was set to 100kHz from 30MHz-1GHz and 1MHz for measurements above 1GHz. All plots were corrected for cable loss.

**Test Results:** Equipment is compliant with the Receiver Spurious Emissions Requirements of RSS-GEN.

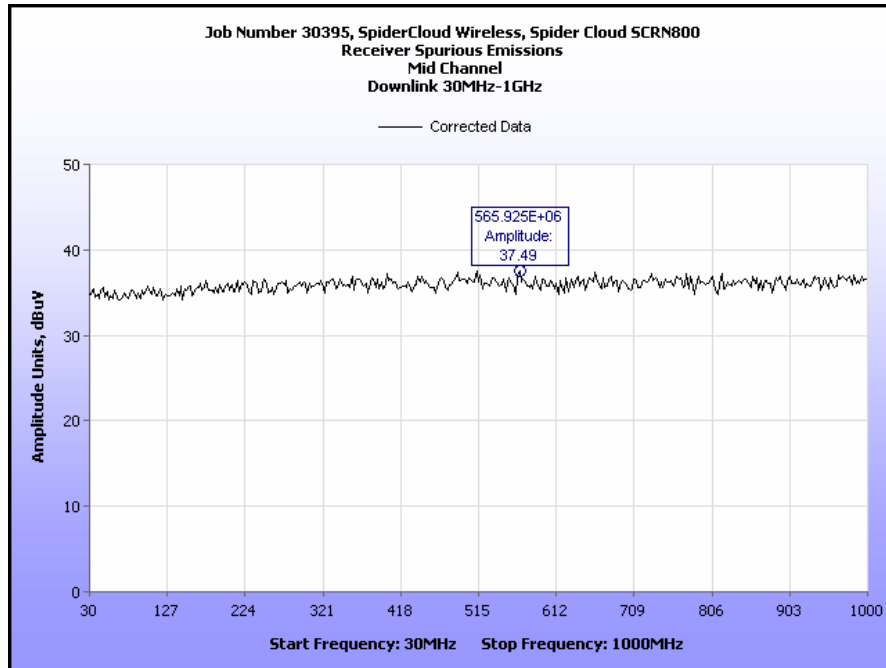
**Test Engineer(s):** Manasi Bhandiwad

**Test Date(s):** 12/13/10

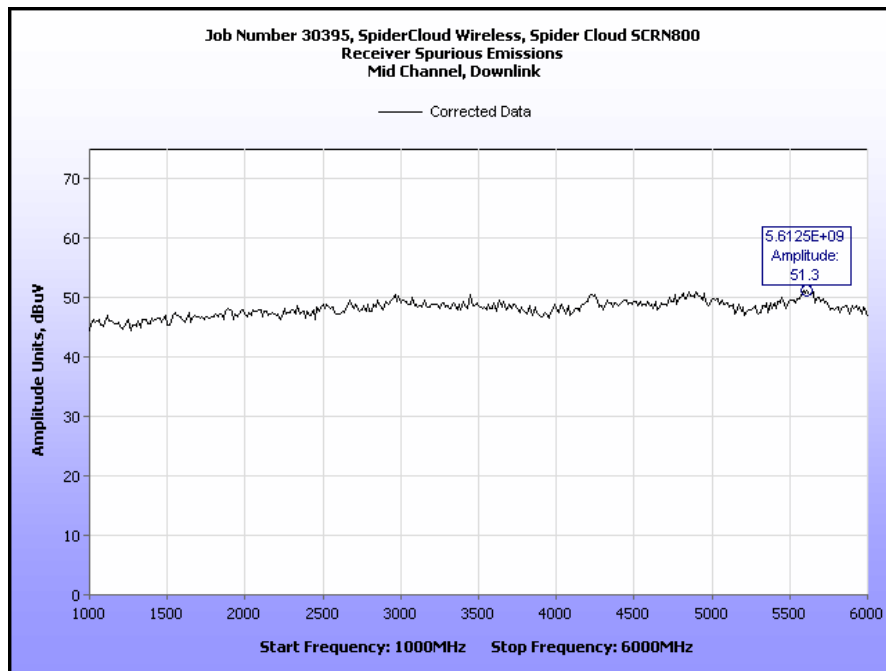


**Figure 2. Block Diagram, Conducted Receiver Spurious Emissions Test Setup**

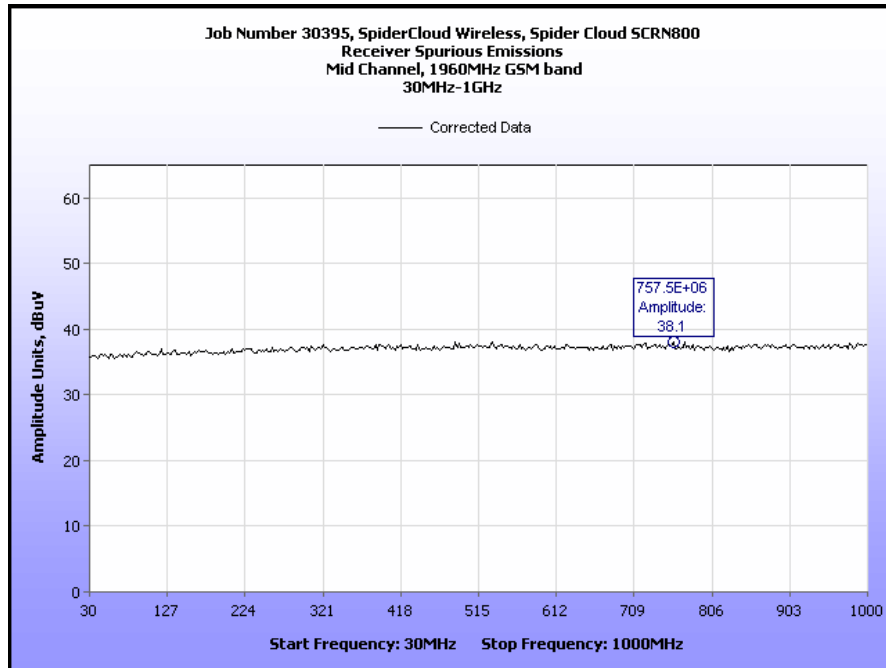
### Conducted Receiver Spurious Emissions



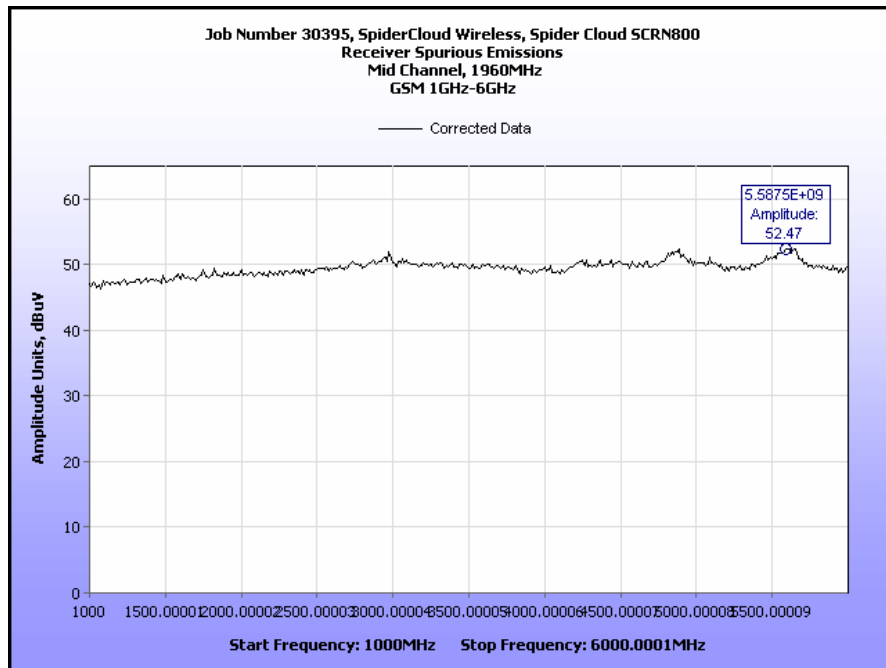
Plot 37. Receiver Spurious Emissions, Mid Channel, Downlink, 30 MHz – 1 GHz



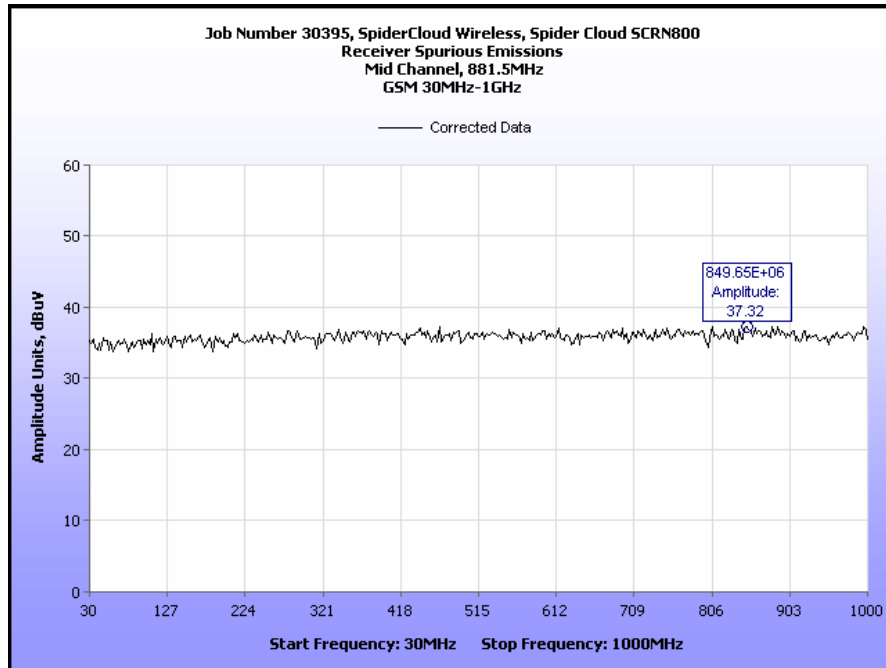
Plot 38. Receiver Spurious Emissions, Mid Channel, Downlink, 1 GHz – 6 GHz



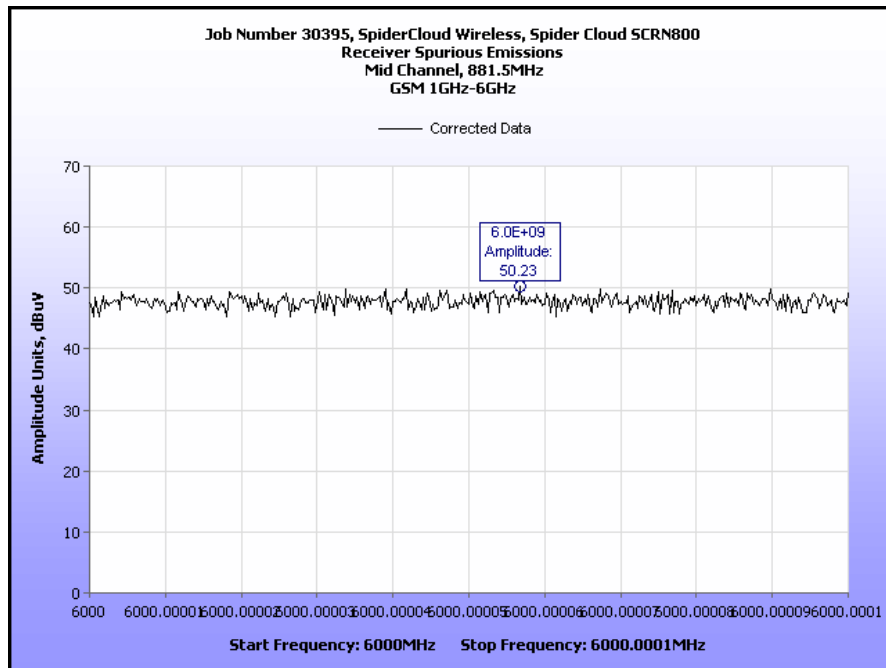
Plot 39. Receiver Spurious Emissions, GSM 1900 Band, 30 MHz – 1 GHz



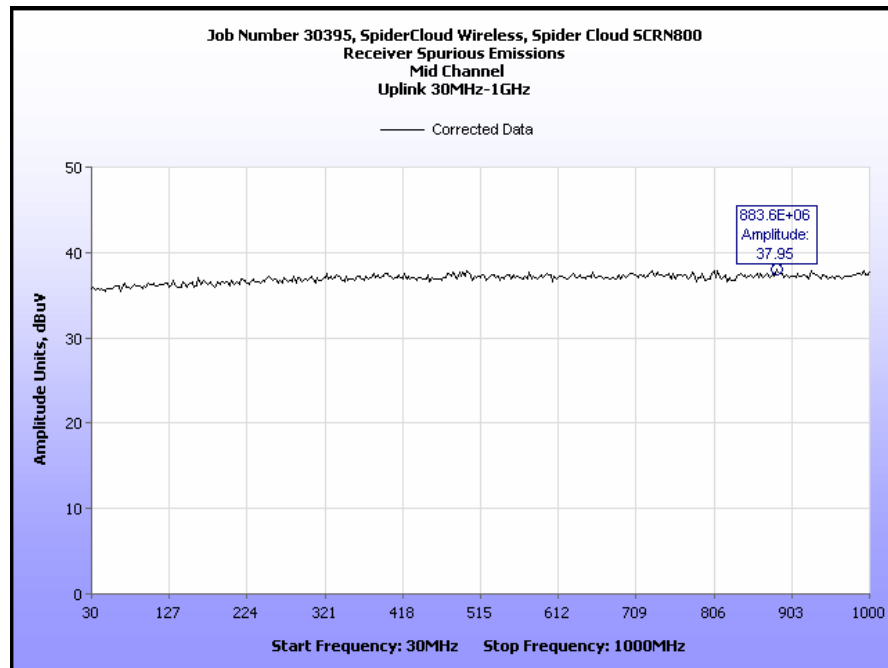
Plot 40. Receiver Spurious Emissions, GSM 1900 Band, 1 GHz – 6 GHz



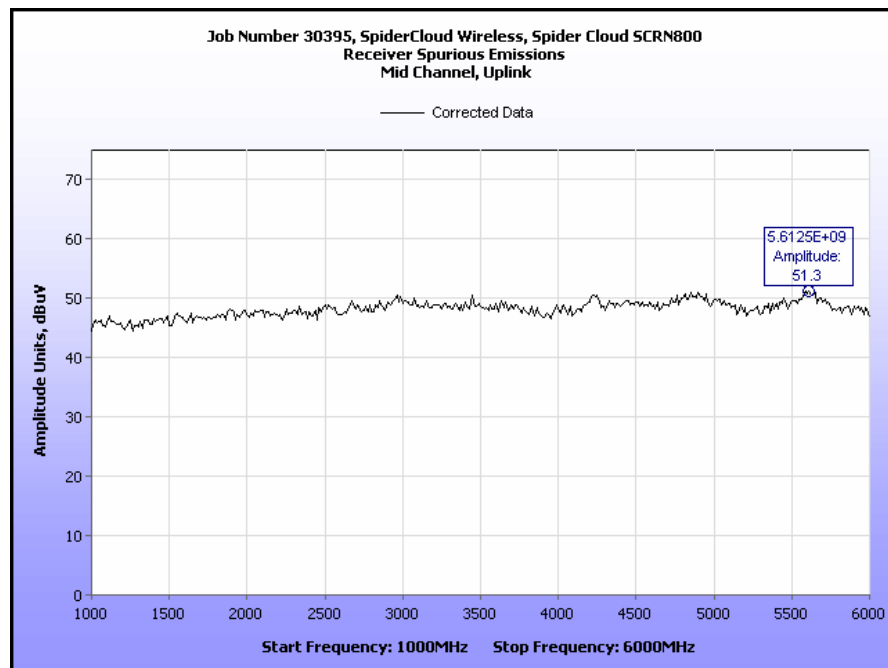
Plot 41. Receiver Spurious Emissions, Mid Channel, GSM 850, 30 MHz – 1 GHz



Plot 42. Receiver Spurious Emissions, Mid Channel, GSM 850, 1 GHz – 6 GHz



Plot 43. Receiver Spurious Emissions, Mid Channel, Uplink, 30 MHz – 1 GHz



Plot 44. Receiver Spurious Emissions, Mid Channel, Uplink, 1 GHz – 6 GHz



## Electromagnetic Compatibility Criteria for Intentional Radiators

### §2.1055 Frequency Stability

**Test Requirement(s):** §2.1055 and §24.135

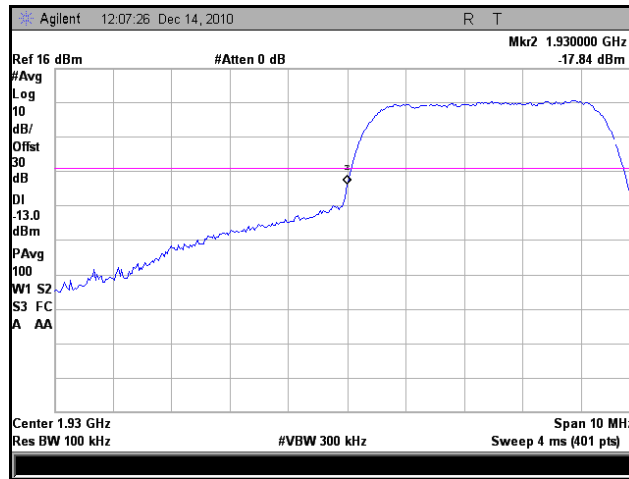
**Test Procedures:** As required by 47 CFR 2.1055, *Frequency Stability measurements* were made at the RF output terminals using a Directional Coupler through a Spectrum Analyzer and Power Meter.

The EUT was setup in an Environmental chamber with the support equipment outside the chamber. The EUT was set to transmit on the low channel. The out of band emissions were then compared to the -13dBm limit. The same procedure was repeated on the high channel. This procedure was done at a temperature range of -30C to +50C. At the ambient temperature, in addition to the measurements at the nominal voltage, the voltage was varied to +/- 15% and measurements were taken at those voltages.

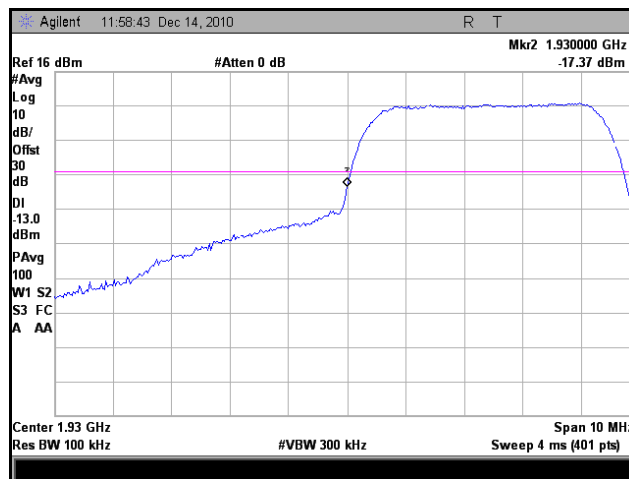
**Test Results:** Equipment is compliant with Section 2.1055 and §24.135.

**Test Engineer(s):** Manasi Bhandiwad

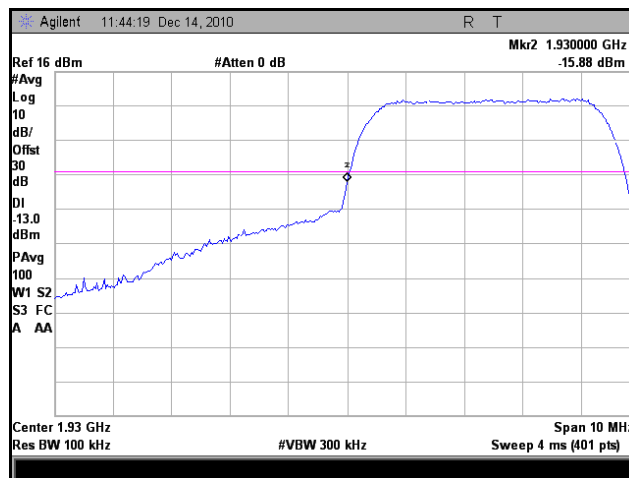
**Test Date(s):** 12/14/10



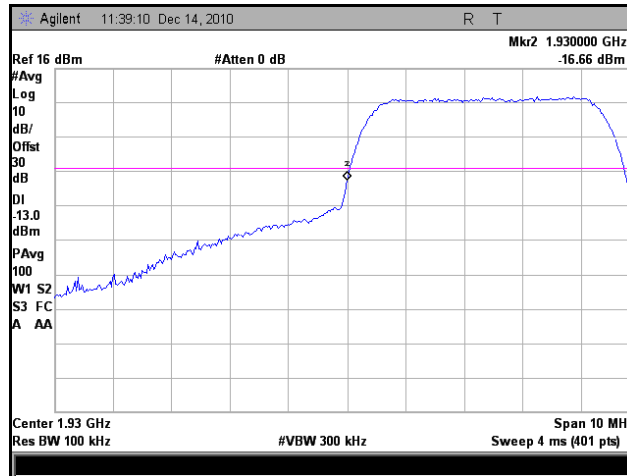
Plot 45. Frequency Stability, Low Band Edge, -30°C



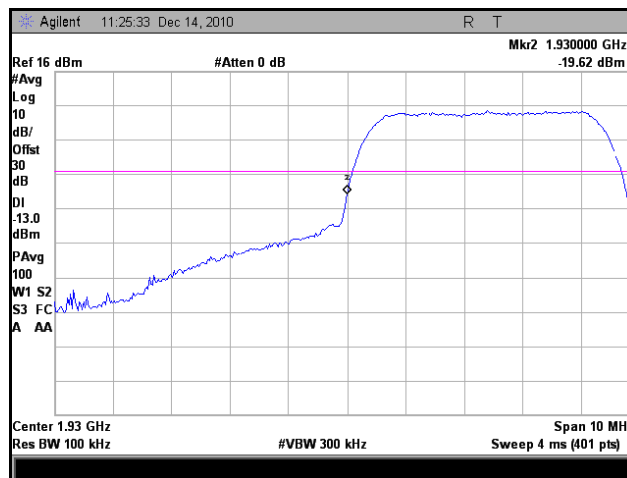
Plot 46. Frequency Stability, Low Band Edge, -20°C



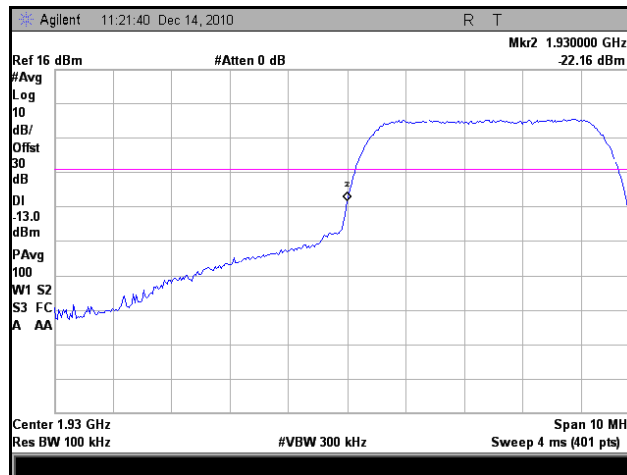
Plot 47. Frequency Stability, Low Band Edge, -10°C



Plot 48. Frequency Stability, Low Band Edge, 0°C

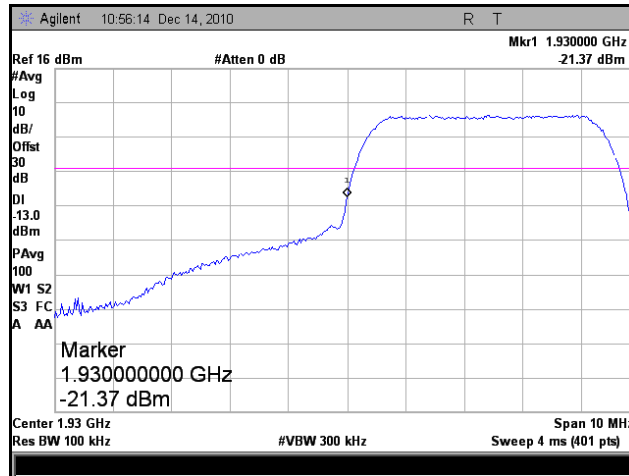


Plot 49. Frequency Stability, Low Band Edge, 10°C

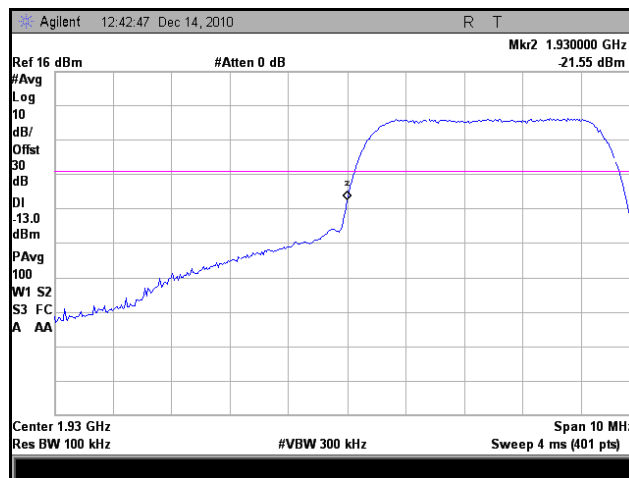


Plot 50. Frequency Stability, Low Band Edge, 20°C

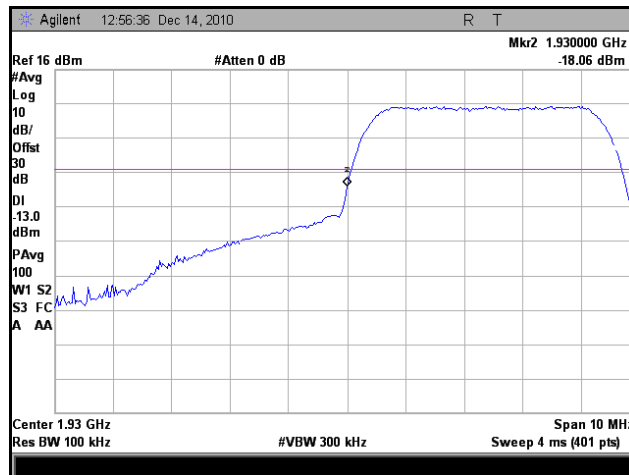




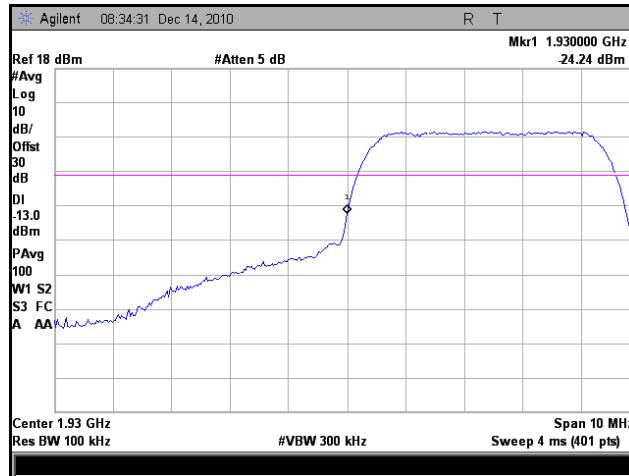
Plot 51. Frequency Stability, Low Band Edge, 30°C



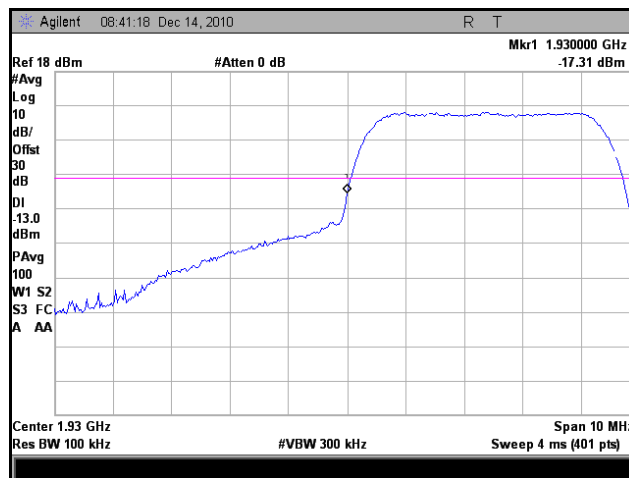
Plot 52. Frequency Stability, Low Band Edge, 40°C



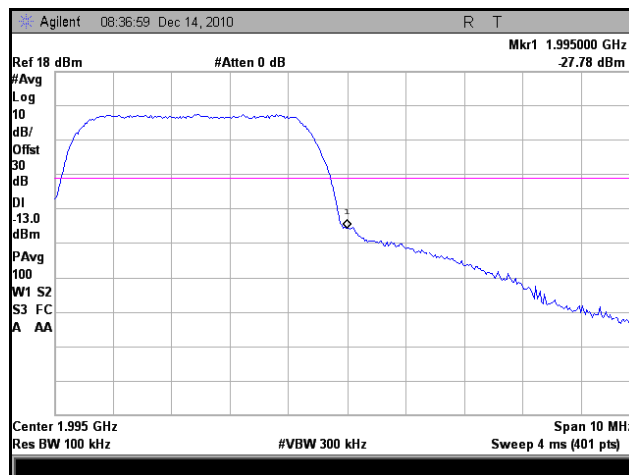
Plot 53. Frequency Stability, Low Band Edge, 50°C



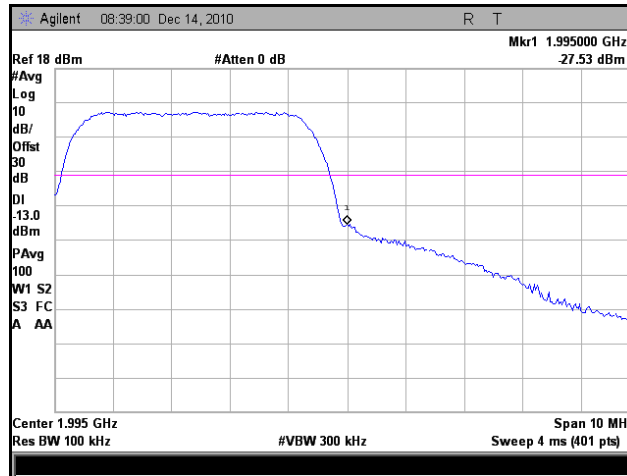
Plot 54. Frequency Stability, Normal, Low Band Edge, Low Voltage



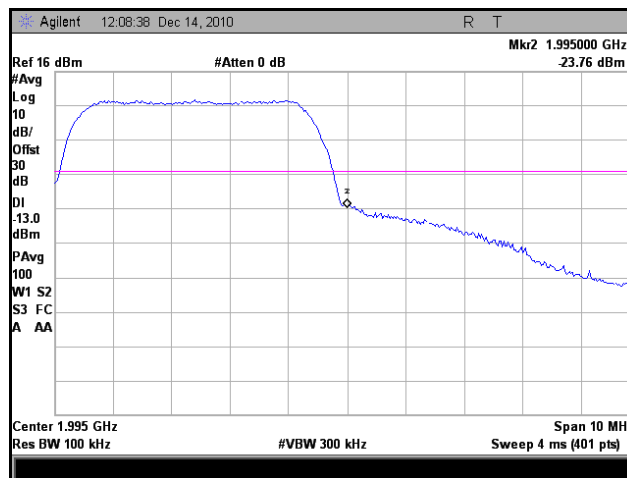
Plot 55. Frequency Stability, Normal, Low Band Edge, High Voltage



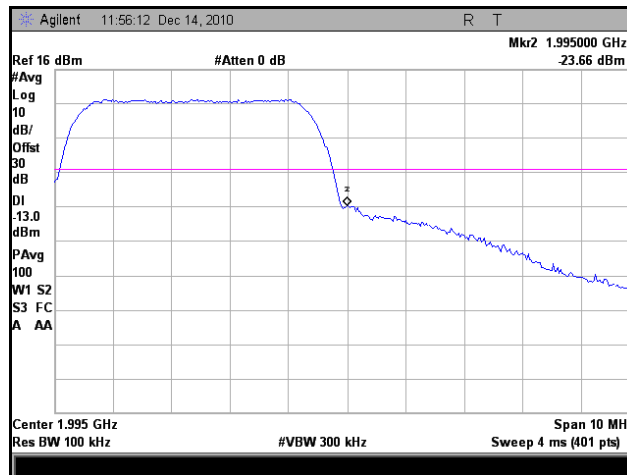
Plot 56. Frequency Stability, Normal, High Band Edge, Low Voltage



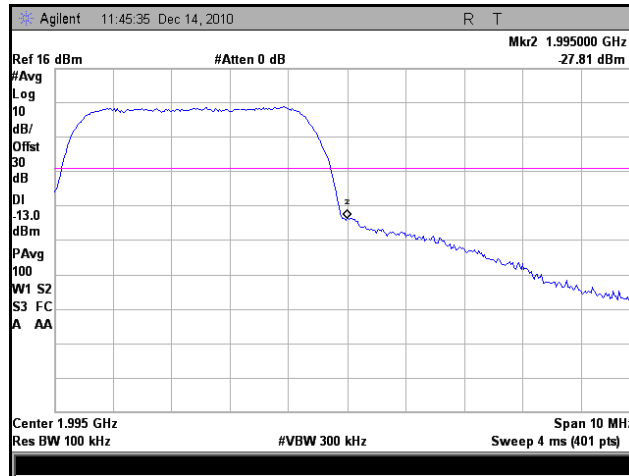
Plot 57. Frequency Stability, Normal, High Band Edge, High Voltage



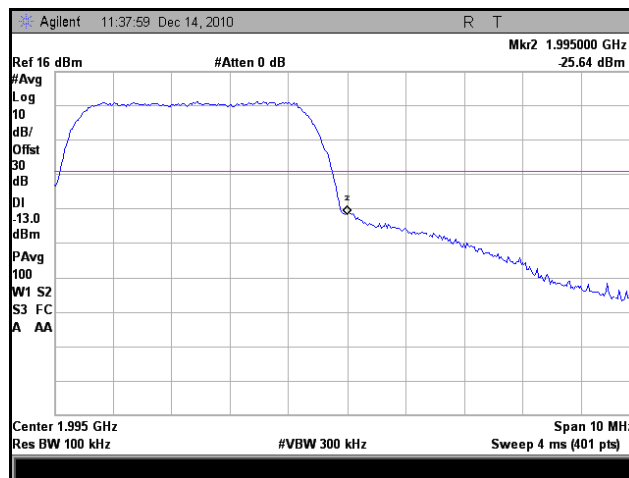
Plot 58. Frequency Stability, High Band Edge, -30°C



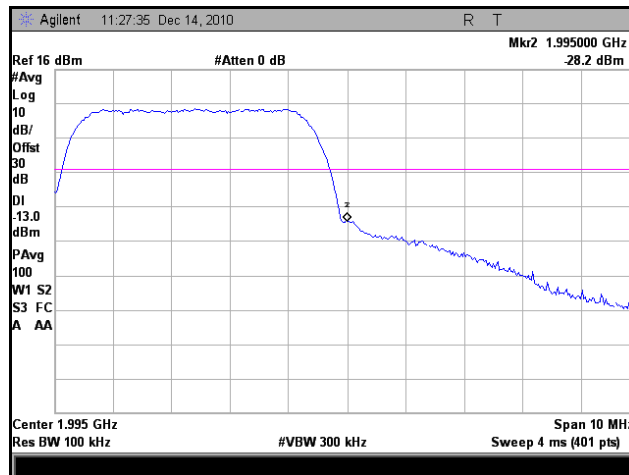
Plot 59. Frequency Stability, High Band Edge, -20°C



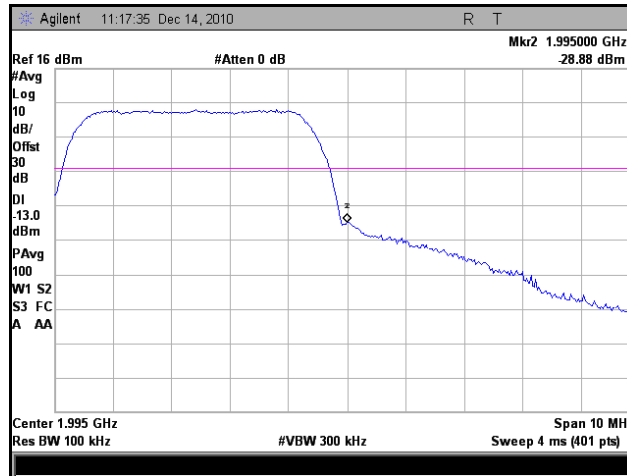
Plot 60. Frequency Stability, High Band Edge, -10°C



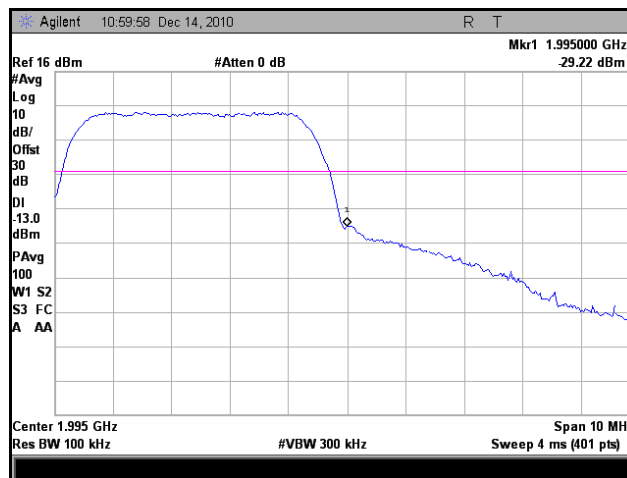
Plot 61. Frequency Stability, High Band Edge, 0°C



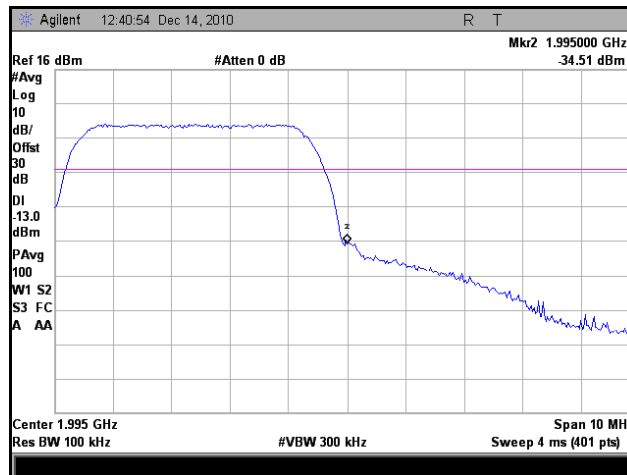
Plot 62. Frequency Stability, High Band Edge, 10°C



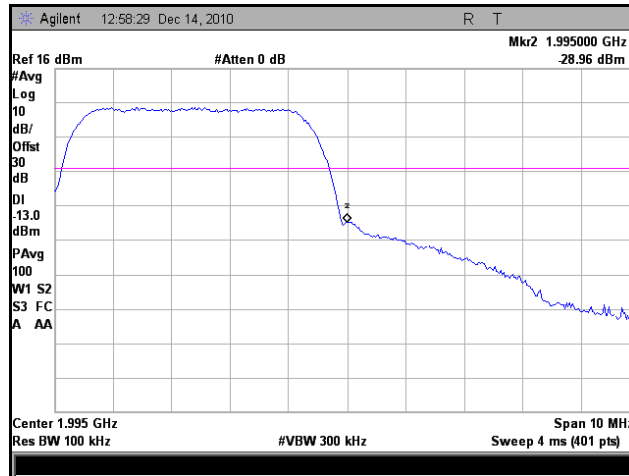
Plot 63. Frequency Stability, High Band Edge, 20°C



Plot 64. Frequency Stability, High Band Edge, 30°C



Plot 65. Frequency Stability, High Band Edge, 40°C



Plot 66. Frequency Stability, High Band Edge, 50°C



## IV. Test Equipment



## Test Equipment

Calibrated test equipment utilized during testing was maintained in a current state of calibration per the requirements of ANSI/NCSL Z540-1-1994 and ANSI/ISO/IEC 17025:2000.

MET #	Equipment	Manufacturer	Model#	Cal Date	Cal Due
1T4612	ESA-E SERIES SPECTRUM ANALYZER	AGILENT	E4407B	09/27/2010	09/27/2011
1T4564	LISN (24 AMP)	SOLAR ELECTRONICS	9252-50-R-24-BNC	10/06/2010	10/06/2011
1T4097	PROBE; RF ABSORBING	FISCHER CUSTOM COMMUNICATIONS	F-201	11/22/2010	11/22/2011
1T4502	COMB GENERATOR	COM-POWER	CGC-255	10/06/2010	10/06/2011
1T4632	THERMO/HYGROMETER	CONTROL COMPANY	S6-627-9	10/09/2009	10/09/2011
1T4300	SEMI-ANECHOIC CHAMBER # 1	EMC TEST SYSTEMS	NONE	08/23/2010	08/23/2013
1T4409	EMI RECEIVER	ROHDE & SCHWARZ	ESIB7	05/25/2010	05/25/2011
1T4751	ANTENNA - BILOG	SUNOL SCIENCES	JB6	11/03/2010	11/03/2011
1T4568	RADIATING NOISE SOURCE	MET LABORATORIES	N/A	SEE NOTE	
1T4627	THERMO/HYGROMETER	CONTROL COMPANY	S6-627-9	10/09/2009	10/09/2011

**Table 16. Test Equipment List**

Note: Functionally tested equipment is verified using calibrated instrumentation at the time of testing.





## **V. Certification & User's Manual Information**



---

## Certification & User's Manual Information

### A. Certification Information

The following is extracted from Title 47 of the Code of Federal Regulations, Part 2, Subpart I — Marketing of Radio frequency devices:

#### § 2.801 Radio-frequency device defined.

As used in this part, a radio-frequency device is any device which in its operation is capable of Emitting radio-frequency energy by radiation, conduction, or other means. Radio- frequency devices include, but are not limited to:

- (a) The various types of radio communication transmitting devices described throughout this chapter.
- (b) *The incidental, unintentional and intentional radiators defined in Part 15 of this chapter.*
- (c) The industrial, scientific, and medical equipment described in Part 18 of this chapter.
- (d) Any part or component thereof which in use emits radio-frequency energy by radiation, conduction, or other means.

#### § 2.803 Marketing of radio frequency devices prior to equipment authorization.

- (a) Except as provided elsewhere in this chapter, no person shall sell or lease, or offer for sale or lease (including advertising for sale or lease), or import, ship or distribute for the purpose of selling or leasing or offering for sale or lease, any radio frequency device unless:
  - (1) In the case of a device subject to certification, such device has been authorized by the Commission in accordance with the rules in this chapter and is properly identified and labeled as required by §2.925 and other relevant sections in this chapter; or
  - (2) In the case of a device that is not required to have a grant of equipment authorization issued by the Commission, but which must comply with the specified technical standards prior to use, such device also complies with all applicable administrative (including verification of the equipment or authorization under a Declaration of Conformity, where required), technical, labeling and identification requirements specified in this chapter.
- (d) Notwithstanding the provisions of paragraph (a) of this section, the offer for sale solely to business, commercial, industrial, scientific or medical users (but not an offer for sale to other parties or to end users located in a residential environment) of a radio frequency device that is in the conceptual, developmental, design or pre-production stage is permitted prior to equipment authorization or, for devices not subject to the equipment authorization requirements, prior to a determination of compliance with the applicable technical requirements *provided* that the prospective buyer is advised in writing at the time of the offer for sale that the equipment is subject to the FCC rules and that the equipment will comply with the appropriate rules before delivery to the buyer or to centers of distribution.



- (e)(1) Notwithstanding the provisions of paragraph (a) of this section, prior to equipment authorization or determination of compliance with the applicable technical requirements any radio frequency device may be operated, but not marketed, for the following purposes and under the following conditions:
- (i) *Compliance testing;*
  - (ii) Demonstrations at a trade show provided the notice contained in paragraph (c) of this section is displayed in a conspicuous location on, or immediately adjacent to, the device;
  - (iii) Demonstrations at an exhibition conducted at a business, commercial, industrial, scientific or medical location, but excluding locations in a residential environment, provided the notice contained in paragraphs (c) or (d) of this section, as appropriate, is displayed in a conspicuous location on, or immediately adjacent to, the device;
  - (iv) Evaluation of product performance and determination of customer acceptability, provided such operation takes place at the manufacturer's facilities during developmental, design or pre-production states; or
  - (v) Evaluation of product performance and determination of customer acceptability where customer acceptability of a radio frequency device cannot be determined at the manufacturer's facilities because of size or unique capability of the device, provided the device is operated at a business, commercial, industrial, scientific or medical user's site, but not at a residential site, during the development, design or pre-production stages.
- (e)(2) For the purpose of paragraphs (e)(1)(iv) and (e)(1)(v) of this section, the term *manufacturer's facilities* includes the facilities of the party responsible for compliance with the regulations and the manufacturer's premises, as well as the facilities of other entities working under the authorization of the responsible party in connection with the development and manufacture, but not the marketing, of the equipment.
- (f) For radio frequency devices subject to verification and sold solely to business, commercial, industrial, scientific and medical users (excluding products sold to other parties or for operation in a residential environment), parties responsible for verification of the devices shall have the option of ensuring compliance with the applicable technical specifications of this chapter at each end user's location after installation, provided that the purchase or lease agreement includes a proviso that such a determination of compliance be made and is the responsibility of the party responsible for verification of the equipment.



---

## Certification & User's Manual Information

The following is extracted from Title 47 of the Code of Federal Regulations, Part 2, Subpart J — Equipment Authorization Procedures:

### § 2.901 Basis and Purpose

- (a) In order to carry out its responsibilities under the Communications Act and the various treaties and international regulations, and in order to promote efficient use of the radio spectrum, the Commission has developed technical standards for radio frequency equipment and parts or components thereof. The technical standards applicable to individual types of equipment are found in that part of the rules governing the service wherein the equipment is to be operated.<sup>1</sup> *In addition to the technical standards provided, the rules governing the service may require that such equipment be verified by the manufacturer or importer, be authorized under a Declaration of Conformity, or receive an equipment authorization from the Commission by one of the following procedures: certification or registration.*
- (b) The following sections describe the verification procedure, the procedure for a Declaration of Conformity, and the procedures to be followed in obtaining certification from the Commission and the conditions attendant to such a grant.

### § 2.907 Certification.

- (a) Certification is an equipment authorization issued by the Commission, based on representation and test data submitted by the applicant.
- (b) Certification attaches to all units subsequently marketed by the grantee which are identical (see Section 2.908) to the sample tested except for permissive changes or other variations authorized by the Commission pursuant to Section 2.1043.

---

<sup>1</sup> In this case, the equipment is subject to the rules of Part 15. More specifically, the equipment falls under Subpart B (of Part 15), which deals with unintentional radiators.



---

## Certification & User's Manual Information

### § 2.948 Description of measurement facilities.

- (a) Each party making measurements of equipment that is subject to an equipment authorization under Part 15 or Part 18 of this chapter, regardless of whether the measurements are filed with the Commission or kept on file by the party responsible for compliance of equipment marketed within the U.S. or its possessions, shall compile a description of the measurement facilities employed.
  - (1) If the measured equipment is subject to the verification procedure, the description of the measurement facilities shall be retained by the party responsible for verification of the equipment.
    - (i) *If the equipment is verified through measurements performed by an independent laboratory, it is acceptable for the party responsible for verification of the equipment to rely upon the description of the measurement facilities retained by or placed on file with the Commission by that laboratory. In this situation, the party responsible for the verification of the equipment is not required to retain a duplicate copy of the description of the measurement facilities.*
    - (ii) If the equipment is verified based on measurements performed at the installation site of the equipment, no specific site calibration data is required. It is acceptable to retain the description of the measurement facilities at the site at which the measurements were performed.
  - (2) If the equipment is to be authorized by the Commission under the certification procedure, the description of the measurement facilities shall be filed with the Commission's Laboratory in Columbia, Maryland. The data describing the measurement facilities need only be filed once but must be updated as changes are made to the measurement facilities or as otherwise described in this section. At least every three years, the organization responsible for filing the data with the Commission shall certify that the data on file is current.



---

## Certification & User's Manual Information

### Label and User's Manual Information

The following is extracted from Title 47 of the Code of Federal Regulations, Part 15, Subpart A — General:

#### § 15.19 Labeling requirements.

(a) *In addition to the requirements in Part 2 of this chapter, a device subject to certification or verification shall be labeled as follows:*

- (1) Receivers associated with the operation of a licensed radio service, e.g., FM broadcast under Part 73 of this chapter, land mobile operation under Part 90, etc., shall bear the following statement in a conspicuous location on the device:

*This device complies with Part 15 of the FCC Rules. Operation is subject to the condition that this device does not cause harmful interference.*

- (2) A stand-alone cable input selector switch, shall bear the following statement in a conspicuous location on the device:

*This device is verified to comply with Part 15 of the FCC Rules for use with cable television service.*

- (3) All other devices shall bear the following statement in a conspicuous location on the device:

*This device complies with Part 15 of the FCC Rules. Operation is subject to the following two conditions: (1) This device may not cause harmful interference, and (2) this device must accept any interference received, including interference that may cause undesired operation.*

- (4) Where a device is constructed in two or more sections connected by wires and marketed together, the statement specified under paragraph (a) of this section is required to be affixed only to the main control unit.

- (5) When the device is so small or for such use that it is not practicable to place the statement specified under paragraph (a) of this section on it, the information required by this paragraph shall be placed in a prominent location in the instruction manual or pamphlet supplied to the user or, alternatively, shall be placed on the container in which the device is marketed. However, the FCC identifier or the unique identifier, as appropriate, must be displayed on the device.

#### § 15.21 Information to user.

The users manual or instruction manual for an intentional or unintentional radiator shall caution the user that changes or modifications not expressly approved by the party responsible for compliance could void the user's authority to operate the equipment.



---

## Verification & User's Manual Information

The following is extracted from Title 47 of the Code of Federal Regulations, Part 15, Subpart B — Unintentional Radiators:

### § 15.105 Information to the user.

- (a) For a Class B digital device or peripheral, the instructions furnished the user shall include the following or similar statement, placed in a prominent location in the text of the manual:

Note: This equipment has been tested and found to comply with the limits for a Class B digital device, pursuant to Part 15 of the FCC Rules. These limits are designed to provide reasonable protection against harmful interference when the equipment is operated in a residential environment. This equipment generates, uses, and can radiate radio frequency energy and, if not installed and used in accordance with the instruction manual, may cause harmful interference to radio communications. However, there is no guarantee that interference will not occur in a particular installation. If this equipment does cause harmful interference to radio or television reception, which can be determined by turning the equipment off and on, the user is encouraged to try to correct the interference by one or more of the following measures:

- Reorient or relocate the receiving antenna.
- Increase the separation between the equipment and receiver.
- Connect the equipment into an outlet on a circuit different from that to which the receiver is connected.
- Consult the dealer or an experienced radio/TV technician for help.



# End of Report