



# RF TEST REPORT



Report No.: FCC\_SL17110601-SPC-013

Supersede Report No.:

Applicant	SpiderCloud Wireless, Inc.		
Product Name	SpiderCloud Radio Node		
Model No.	SCRN-320-0446		
Test Standard	47CFR Part 24/27		
Test Method	TIA-603-D: 2010		
FCC ID	Y47RN320B446		
Date of test	01/18/2017 - 11/22/2017		
Issue Date	11/22/2017		
Test Result	<u>Pass</u>	Fail	
Equipment complied with the specification		[ x ]	
Equipment did not comply with the specification		[ ]	
			
Gary Chou		Chen Ge	
Test Engineer		Engineer Reviewer	
<p>This test report may be reproduced in full only            Test result presented in this test report is applicable to the tested sample only</p>			

**Issued By:**  
**SIEMIC Laboratories**  
**775 Montague Expressway, Milpitas, 95035 CA**



775 Montague Expressway, Milpitas, CA 95035, USA • Phone: (+1) 408 526 1188 • Facsimile (+1) 408 526 1088

Visit us at: [www.siemic.com](http://www.siemic.com); Follow us at: 

## Laboratory Introduction

SIEMIC, headquartered in the heart of Silicon Valley, with superior facilities in US and Asia, is one of the leading independent testing and certification facilities providing customers with one-stop shop services for Compliance Testing and Global Certifications.



In addition to testing and certification, SIEMIC provides initial design reviews and compliance management throughout a project. Our extensive experience with China, Asia Pacific, North America, European, and International compliance requirements, assures the fastest, most cost effective way to attain regulatory compliance for the global markets.

### Accreditations for Conformity Assessment

Country/Region	Accreditation Body	Scope
USA	FCC, A2LA	EMC , RF/Wireless , Telecom
Canada	IC, A2LA, NIST	EMC, RF/Wireless , Telecom
Taiwan	BSMI , NCC , NIST	EMC, RF, Telecom , Safety
Hong Kong	OFTA , NIST	RF/Wireless , Telecom
Australia	NATA, NIST	EMC, RF, Telecom , Safety
Korea	KCC/RRA, NIST	EMI, EMS, RF , Telecom, Safety
Japan	VCCI, JATE, TELEC, RFT	EMI, RF/Wireless, Telecom
Mexico	NOM, COFETEL, Caniety	Safety, EMC , RF/Wireless, Telecom
Europe	A2LA, NIST	EMC, RF, Telecom , Safety
Israel	MOC, NIST	EMC, RF, Telecom, Safety

### Accreditations for Product Certifications

Country	Accreditation Body	Scope
USA	FCC TCB, NIST	EMC , RF , Telecom
Canada	IC FCB , NIST	EMC , RF , Telecom
Singapore	iDA, NIST	EMC , RF , Telecom
EU	NB	EMC & R&TTE Directive
Japan	MIC (RCB 208)	RF , Telecom
HongKong	OFTA (US002)	RF , Telecom

## **CONTENTS**

<b>1</b>	<b>REPORT REVISION HISTORY .....</b>	<b>4</b>
<b>2</b>	<b>EXECUTIVE SUMMARY .....</b>	<b>5</b>
<b>3</b>	<b>CUSTOMER INFORMATION .....</b>	<b>5</b>
<b>4</b>	<b>TEST SITE INFORMATION .....</b>	<b>5</b>
<b>5</b>	<b>MODIFICATION .....</b>	<b>5</b>
<b>6</b>	<b>EUT INFORMATION .....</b>	<b>6</b>
6.1	EUT Description .....	6
6.2	Radio Description .....	7
6.3	EUT test modes/configuration Description.....	8
6.4	EUT Photos .....	9
6.5	EUT Test Setup Photos .....	10
<b>7</b>	<b>SUPPORTING EQUIPMENT/SOFTWARE AND CABLING DESCRIPTION.....</b>	<b>11</b>
7.1	Supporting Equipment .....	11
7.2	Cabling Description .....	11
7.3	Test Software Description .....	11
<b>8</b>	<b>TEST SUMMARY.....</b>	<b>12</b>
<b>9</b>	<b>MEASUREMENT UNCERTAINTY .....</b>	<b>13</b>
9.1	Conducted Emissions .....	13
9.2	Radiated Emissions (30MHz to 1GHz).....	13
9.3	Radiated Emissions (1GHz to 40GHz).....	14
9.4	RF conducted measurement.....	14
<b>10</b>	<b>MEASUREMENTS, EXAMINATION AND DERIVED RESULTS.....</b>	<b>15</b>
10.1	RF Output Power .....	15
10.2	Peak-Average Ratio .....	50
10.3	Occupied Bandwidth .....	74
10.4	Band Edge .....	98
10.5	Radiated Spurious Emission below 1GHz.....	119
10.6	Radiated Spurious Emissions above 1GHz.....	121
10.7	Frequency Stability.....	124
<b>ANNEX A. TEST INSTRUMENT.....</b>		<b>126</b>
<b>ANNEX B. SIEMIC ACCREDITATION .....</b>		<b>127</b>

## 1 Report Revision History

Report No.	Report Version	Description	Issue Date
FCC_SL17110601-SPC-013	None	Original	11/08/2017

## 2 Executive Summary

The purpose of this test program was to demonstrate compliance of following product

Company: SpiderCloud Wireless, Inc.  
Product: SpiderCloud Radio Node  
Model: SCRN-320-0446

against the current Stipulated Standards. The specified model product stated above has demonstrated compliance with the Stipulated Standard listed on 1<sup>st</sup> page.

## 3 Customer information

Applicant Name	SpiderCloud Wireless
Applicant Address	475 Sycamore Dr, Milpitas, CA, 95035, USA
Manufacturer Name	Flextronics International USA, Inc
Manufacturer Address	927 Gibraltar Dr., Bldg. 6, Milpitas, CA, 95035, USA

## 4 Test site information

Lab performing tests	SIEMIC Laboratories
Lab Address	775 Montague Expressway, Milpitas, CA 95035
FCC Test Site No.	881796
IC Test Site No.	4842D-2
VCCI Test Site No.	A0133

## 5 Modification

Index	Item	Description	Note
-	-	-	-

## 6 EUT Information

### 6.1 EUT Description

Product Name	SpiderCloud Radio Node
Model No.	SCRN-320-0446
Trade Name	SpiderCloud
Serial No.	16298X25436
Input Power	56VDC (PoE)
Power Adapter Manu/Model	PHIHONG/POE36U-1AT-R
Power Adapter SN	N/A
Date of EUT received	01/13/2017
Equipment Class/ Category	PCB, TNB
Operating Frequencies	LTE: TX (2110 MHz to 2155 MHz), LTE: RX (1710 MHz to 1755 MHz) LTE: TX (2110 MHz to 2200 MHz), LTE: RX (1710 MHz to 1780 MHz)
Port/Connectors	PoE, Ethernet
Remark	NONE

## 6.2 Radio Description

Item	LTE
Operating Band /Radio Type	LTE Band 4
Bandwidth	5MHz, 10MHz, 15MHz, 20MHz
Modulation	QPSK/16QAM/64QAM
Antenna Type	Internal Omni-directional antenna External Omni-directional antenna
Antenna Gain	3dBi
Frequency TX(MHz)	TX: 2110 MHz to 2155 MHz RX: 1710 MHz to 1755 MHz

LTE
LTE Band 66
5MHz, 10MHz, 15MHz, 20MHz
QPSK/16QAM/64QAM
Internal Omni-directional antenna External Omni-directional antenna
3dBi
TX: 2110 MHz to 2200 MHz RX: 1710 MHz to 1780 MHz

### 6.3 EUT test modes/configuration Description

#### Test mode

	Final Test Mode	Note
Final_test_mode_1	Continuous transmission, 5MHz, QPSK, Low CH	LTE
Final_test_mode_2	Continuous transmission, 5MHz, QPSK, Mid CH	LTE
Final_test_mode_3	Continuous transmission, 5MHz, QPSK, High CH	LTE
Final_test_mode_4	Continuous transmission, 5MHz, 64QAM, Low CH	LTE
Final_test_mode_5	Continuous transmission, 5MHz, 64QAM, Mid CH	LTE
Final_test_mode_5	Continuous transmission, 5MHz, 64QAM, High CH	LTE
Final_test_mode_7	Continuous transmission, 10MHz, QPSK, Low CH	LTE
Final_test_mode_8	Continuous transmission, 10MHz, QPSK, Mid CH	LTE
Final_test_mode_9	Continuous transmission, 10MHz, QPSK, High CH	LTE
Final_test_mode_10	Continuous transmission, 10MHz, 64QAM, Low CH	LTE
Final_test_mode_11	Continuous transmission, 10MHz, 64QAM, Mid CH	LTE
Final_test_mode_12	Continuous transmission, 10MHz, 64QAM, High CH	LTE
Final_test_mode_13	Continuous transmission, 15MHz, QPSK, Low CH	LTE
Final_test_mode_14	Continuous transmission, 15MHz, QPSK, Mid CH	LTE
Final_test_mode_15	Continuous transmission, 15MHz, QPSK, High CH	LTE
Final_test_mode_16	Continuous transmission, 15MHz, 64QAM, Low CH	LTE
Final_test_mode_17	Continuous transmission, 15MHz, 64QAM, Mid CH	LTE
Final_test_mode_18	Continuous transmission, 15MHz, 64QAM, High CH	LTE
Final_test_mode_19	Continuous transmission, 20MHz, QPSK, Low CH	LTE
Final_test_mode_20	Continuous transmission, 20MHz, QPSK, Mid CH	LTE
Final_test_mode_21	Continuous transmission, 20MHz, QPSK, High CH	LTE
Final_test_mode_22	Continuous transmission, 20MHz, 64QAM, Low CH	LTE
Final_test_mode_23	Continuous transmission, 20MHz, 64QAM, Mid CH	LTE
Final_test_mode_24	Continuous transmission, 20MHz, 64QAM, High CH	LTE
Remark: N/A.		



### 6.4 EUT Photos

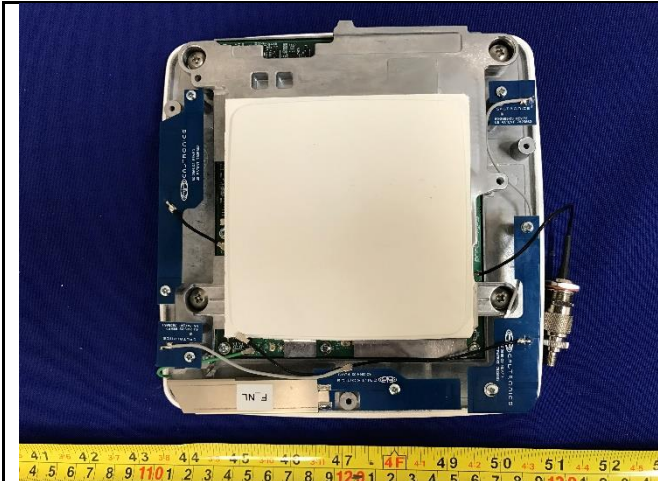

**EUT - Open Case View**



**Main PCB - Top View**

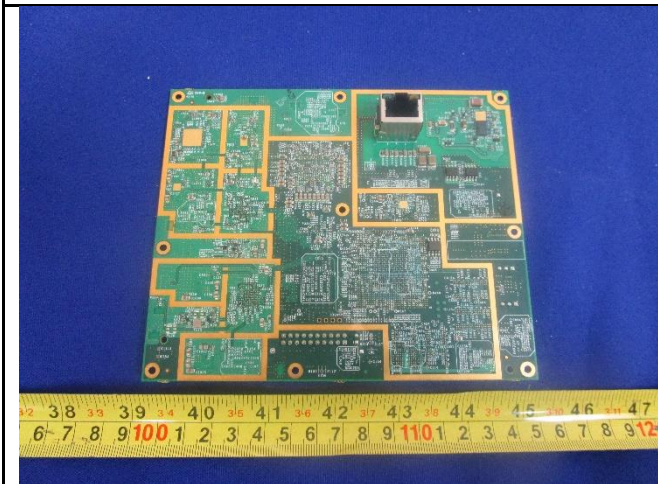

**Main PCB - Bottom View**



**Internal antenna 1**



**Internal antenna 2**

## 6.5 EUT Test Setup Photos

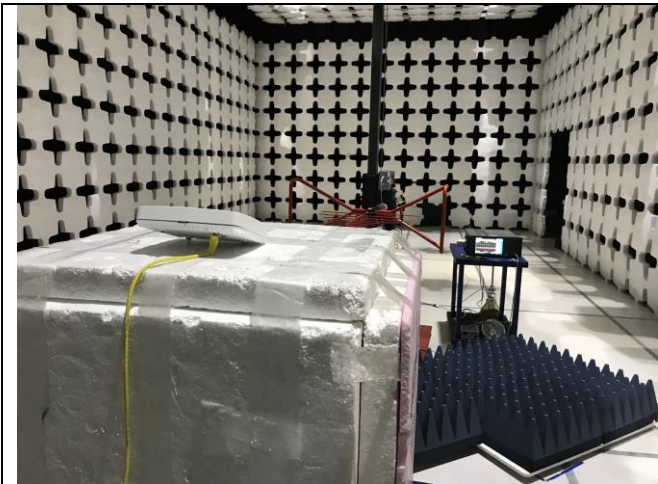

**Radiated Emissions (<1GHz) – Front View**

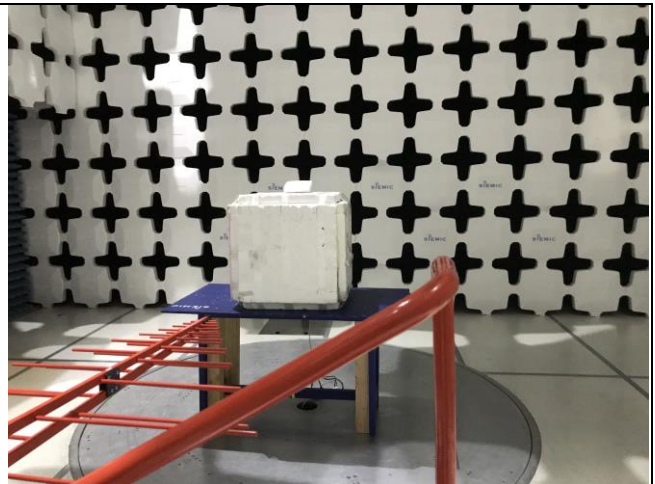

**Radiated Emissions (<1GHz) – Rear View**

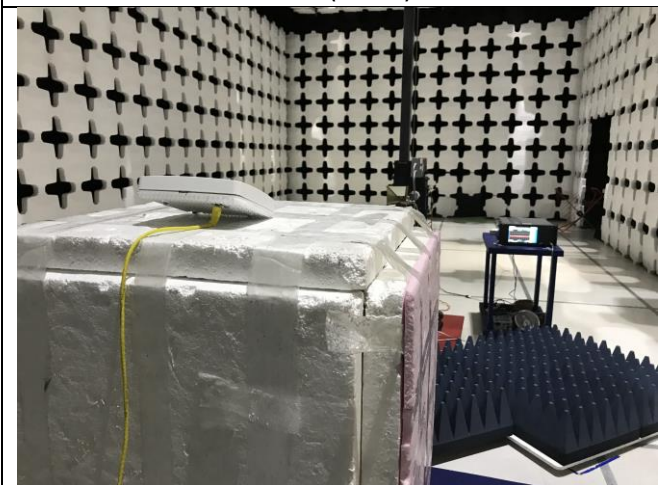

**Radiated Emissions (>1GHz) – Front View**

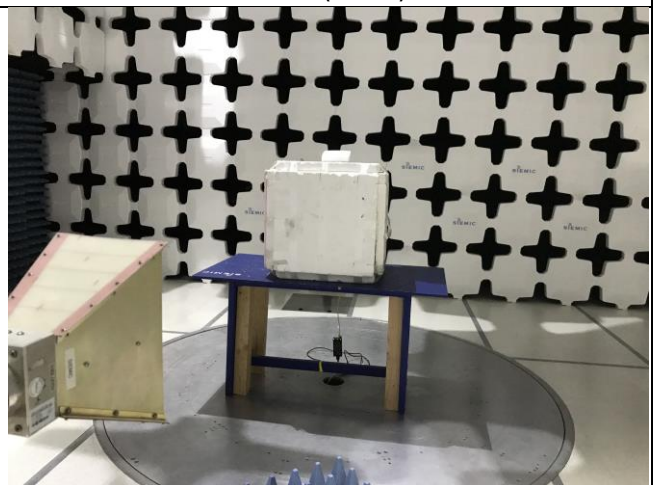

**Radiated Emissions (>1GHz) – Rear View**

Note: The spurious emission in different EUT orientation was investigated, including the EUT standing up position and the laying down position. The EUT orientation shown in above setup photo is the worst case position.



## 8 Test Summary

Test Item	Test standard		Test Method/Procedure		Pass / Fail
E.R.P/ E.I.R.P	FCC	47CFR27.50	FCC	TIA-603-D: 2010	<input checked="" type="checkbox"/> Pass <input type="checkbox"/> N/A
Occupied Bandwidth	FCC	47CFR27.53	FCC	TIA-603-D: 2010	<input checked="" type="checkbox"/> Pass <input type="checkbox"/> N/A
Peak-Average Ratio	FCC	47CFR27.50	FCC	TIA-603-D: 2010	<input checked="" type="checkbox"/> Pass <input type="checkbox"/> N/A
Spurious and harmonic Emission at antenna port	FCC	47CFR2.1051, 47CFR27.53	FCC	TIA-603-D: 2010	<input checked="" type="checkbox"/> Pass <input type="checkbox"/> N/A
Band Edge	FCC	47CFR2.1053, 47CFR27.53	FCC	TIA-603-D: 2010	<input checked="" type="checkbox"/> Pass <input type="checkbox"/> N/A
Radiated spurious and harmonic emission	FCC	47CFR2.1053, 47CFR27.53	FCC	TIA-603-D: 2010	<input checked="" type="checkbox"/> Pass <input type="checkbox"/> N/A
Frequency stability	FCC	47CFR2.1053, 47CFR27.53	FCC	TIA-603-D: 2010	<input checked="" type="checkbox"/> Pass <input type="checkbox"/> N/A
Remark	<ol style="list-style-type: none"> <li>All measurement uncertainties do not take into consideration for all presented test results.</li> <li>The applicant shall ensure frequency stability by showing that an emission is maintained within the band of operation under all normal operating conditions as specified in the user's manual.</li> </ol>				

## 9 Measurement Uncertainty

### 9.1 Conducted Emissions

The test is to measure the conducted emissions to the mains port of the EUT.

Some error sources that can contribute to the total uncertainty:

- Uncertainty of the receiver
- Uncertainty of the LISN
- Uncertainty of cables
- Uncertainty due to the mismatches
- Etc, see the below table for details

Source of Uncertainty	Value (dB)	Probability Distribution	Division	Sensitivity Coefficient	Expanded Uncertainty
Receiver Reading	0.12	Rectangular	1.732	1	0.069284
Cable Insertion Loss	0.21	Normal	2	1	0.105
Filter Insertion Loss	0.25	Normal	2	1	0.125
LISN Insertion Loss	0.40	Normal	2	1	0.20
Receiver CW accuracy	0.5	Rectangular	1.732	1	0.2886836
Pulse Amplitude Response	1.5	Rectangular	1.732	1	0.86605081
PRF Response	1.5	Rectangular	1.732	1	0.86605081
Mismatch LISN - Receiver	0.25	U-Shape	1.414	1	0.1768033
LISN Impedance	2.5	Triangular	2.449	1	1.0208248
Combined Standard Uncertainty					1.928133
<b>Expanded Uncertainty (K=2)</b>					<b>3.856266</b>

The total derived measurement uncertainty is +/- 3.86 dB.

### 9.2 Radiated Emissions (30MHz to 1GHz)

The test is to measure the radiated emissions of the EUT.

Some error sources that can contribute to the total uncertainty:

- Uncertainty of the receiver
- Uncertainty of the antenna
- Uncertainty of cables
- Uncertainty due to the mismatches
- NSA Calibration
- Etc., details see the below table

Source of Uncertainty	Value (dB)	Probability Distribution	Division	Sensitivity Coefficient	Expanded Uncertainty
Receiver Reading	0.12	Rectangular	1.732	1	0.069284
Cable Insertion Loss	0.21	Normal	2	1	0.105
Filter Insertion Loss	0.25	Normal	2	1	0.125
Antenna Factor	0.65	Normal	2	1	0.325
Receiver CW accuracy	0.5	Rectangular	1.732	1	0.2886836
Pulse Amplitude Response	1.5	Rectangular	1.732	1	0.86605081
PRF Response	1.5	Rectangular	1.732	1	0.86605081
Mismatch Filter - Receiver	0.25	U-Shape	1.414	1	0.1768033
NSA Calibration	4.0	U-Shape	1.414	1	2.8288543
Combined Standard Uncertainty					3.0059131
<b>Expanded Uncertainty (K=2)</b>					<b>6.0118262</b>

The total derived measurement uncertainty is +/- 6.00 dB.

### 9.3 Radiated Emissions (1GHz to 40GHz)

The test is to measure the radiated emissions of the EUT.

Some error sources that can contribute to the total uncertainty:

- Uncertainty of the receiver
- Uncertainty of the antenna
- Uncertainty of cables
- Uncertainty due to the mismatches
- VSWR Calibration
- Etc., details see the below table

Source of Uncertainty	Value (dB)	Probability Distribution	Division	Sensitivity Coefficient	Expanded Uncertainty
Receiver Reading	0.12	Rectangular	1.732	1	0.0692840
Cable Insertion Loss	0.21	Normal	2	1	0.1050000
Filter Insertion Loss	0.25	Normal	2	1	0.1250000
Antenna Factor	0.65	Normal	2	1	0.3250000
Receiver CW accuracy	0.5	Rectangular	1.732	1	0.2886836
Pulse Amplitude Response	1.5	Rectangular	1.732	1	0.8660508
PRF Response	1.5	Rectangular	1.732	1	0.8660508
Mismatch Filter - Receiver	0.25	U-Shape	1.414	1	0.1768033
VSWR Calibration	2.0	U-Shape	1.414	1	1.4144272
Combined Standard Uncertainty					4.2363
<b>Expanded Uncertainty (K=2)</b>					<b>8.4726</b>

The total derived measurement uncertainty is +/- 8.47 dB.

### 9.4 RF conducted measurement

The test is to measure the RF output power from the EUT.

Some error sources that can contribute to the total uncertainty:

- Uncertainty of the Reference Level Uncertainty
- Uncertainty of variable attenuators
- Uncertainty of cables
- Uncertainty due to the mismatches

Source of Uncertainty	Value (dB)	Probability Distribution	Division	Sensitivity Coefficient	Expanded Uncertainty
Reference Level	0.12	Rectangular	1.732	1	0.069284
Cable Insertion Loss	0.21	Normal	2	1	0.105
Attenuator	0.25	Normal	2	1	0.125
Mismatch	0.25	U-Shape	1.414	1	0.1768033
Combined Standard Uncertainty					0.476087
<b>Expanded Uncertainty (K=2)</b>					<b>0.952174</b>

The total derived measurement uncertainty is +/- 0.95 dB.

## 10 Measurements, Examination and Derived Results

### 10.1 RF Output Power

Requirement(s):

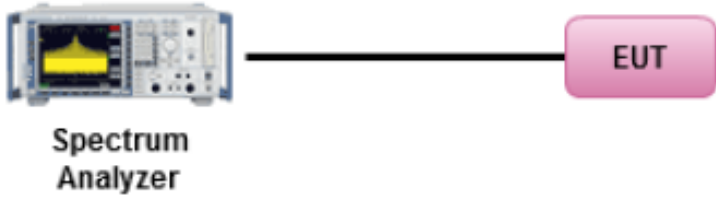
Spec	Item	Requirement	Applicable
47CFR27.50	-	The maximum effective radiated power (ERP) of fixed and base station must not exceed 1000 Watts.	<input checked="" type="checkbox"/>
Test Setup	 <p>The diagram shows a Spectrum Analyzer on the left with a yellow signal on its screen. A black line connects it to a pink rounded rectangle labeled 'EUT' on the right.</p>		
Test Procedure	<ul style="list-style-type: none"> <li>- EUT was set for low, mid, high channel with modulated mode and highest RF output power.</li> <li>- The spectrum analyzer was connected to the antenna terminal.</li> </ul>		
Test Date	01/13/2017 – 06/09/2017	Environmental condition	Temperature 22°C Relative Humidity 48% Atmospheric Pressure 1008mbar
Remark	<p>For LTE mode, EUT is using 2x2 MIMO, which has 2 transmit antennas. They are correlated to each other. The directional gain is calculated per the formula at below,</p> <p style="text-align: center;"><math>\text{Directional gain dBi} = G_{\text{max}} + 10 \text{ Log}_{10} N</math></p> <p>The max gain of single antenna is 3 dBi. So the directional gain = 6 dBi</p>		
Result	<input checked="" type="checkbox"/> Pass <input type="checkbox"/> Fail		

Test Data     Yes                       N/A

Test Plot     Yes (See below)               N/A

Test was done by **Chen Ge** at RF Test Site.

Test Data:

Type	Channel	Frequency (MHz)	Measured PW -Port 1(dBm)	Measured PW -Port 2(dBm)	Combined Power (dBm)	Antenna Gain (dBi)	E.I.R.P (dBm)
5MHz BW, QPSK	Low	2112.5	23.85	23.79	26.83	3	29.83
	Mid	2132.5	23.47	23.47	26.48	3	29.48
	High	2152.5	23.94	23.91	26.94	3	29.94
5MHz BW, 64QAM	Low	2112.5	23.97	23.86	26.93	3	29.93
	Mid	2132.5	23.44	23.48	26.47	3	29.47
	High	2152.5	23.90	23.89	26.91	3	29.91
10MHz BW, QPSK	Low	2115.0	23.62	23.63	26.64	3	29.64
	Mid	2132.5	23.36	23.38	26.38	3	29.38
	High	2150.0	23.68	23.64	26.67	3	29.67
10MHz BW, 64QAM	Low	2115.0	23.63	23.61	26.63	3	29.63
	Mid	2132.5	23.39	23.42	26.42	3	29.42
	High	2150.0	23.56	23.65	26.62	3	29.62
15MHz BW, QPSK	Low	2117.5	23.56	23.53	26.56	3	29.56
	Mid	2132.5	23.36	23.36	26.37	3	29.37
	High	2147.5	23.82	23.79	26.82	3	29.82
15MHz BW, 64QAM	Low	2117.5	23.57	23.54	26.57	3	29.57
	Mid	2132.5	23.34	23.42	26.39	3	29.39
	High	2147.5	23.71	23.76	26.75	3	29.75
20MHz BW, QPSK	Low	2120.0	23.70	23.62	26.67	3	29.67
	Mid	2132.5	23.43	23.45	26.45	3	29.45
	High	2145.0	23.80	23.78	26.80	3	29.80
20MHz BW, 64QAM	Low	2120.0	23.87	23.86	26.88	3	29.88
	Mid	2132.5	23.46	23.45	26.47	3	29.47
	High	2145.0	23.84	23.80	26.83	3	29.83



Test Data for LTE band 66:

Type	Channel	Frequency (MHz)	Measured PW -Port 1(dBm)	Measured PW -Port 2(dBm)	Combined Power (dBm)	Antenna Gain (dBi)	E.I.R.P (dBm)
5MHz BW, QPSK	High	2197.5	24.45	24.43	27.45	3	30.45
5MHz BW, 64QAM	High	2197.5	24.23	24.57	27.41	3	30.41
10MHz BW, QPSK	High	2195	24.45	24.40	27.44	3	30.44
10MHz BW, 64QAM	High	2195	24.56	24.46	27.52	3	30.52
15MHz BW, QPSK	High	2192.5	24.28	24.35	27.33	3	30.33
15MHz BW, 64QAM	High	2192.5	24.24	24.42	27.34	3	30.34
20MHz BW, QPSK	High	2190	24.22	24.18	27.21	3	30.21
20MHz BW, 64QAM	High	2190	24.24	24.23	27.25	3	30.25

Test Plots for Band 4  
Chain 1:

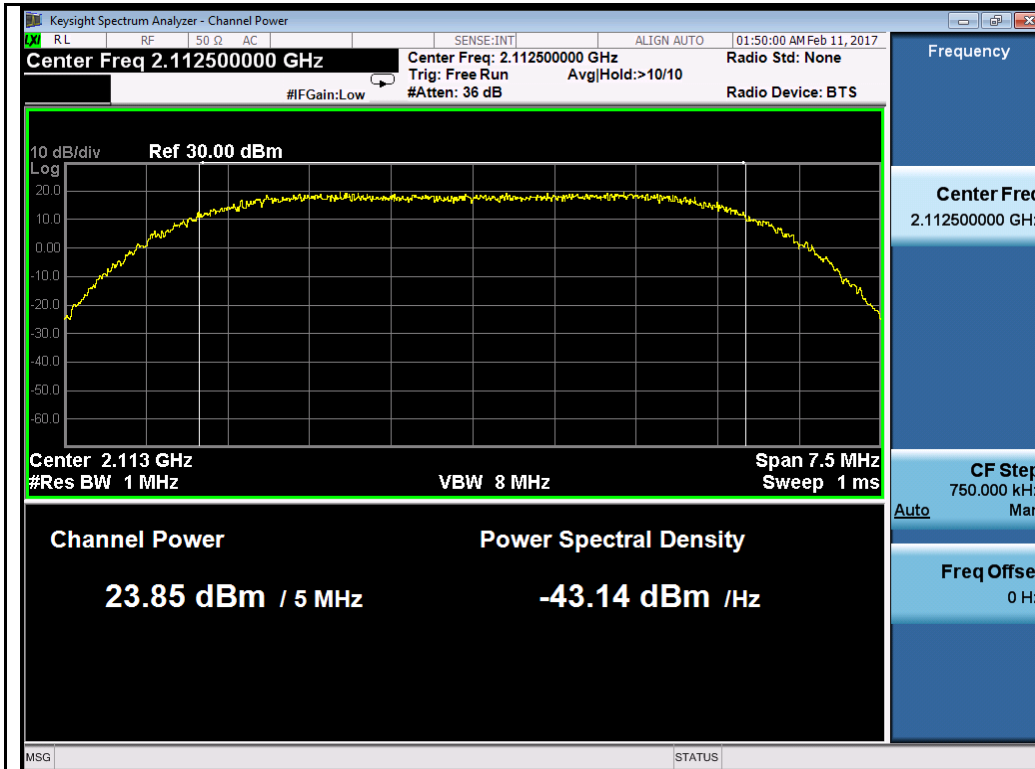

BW 5M QPSK Low

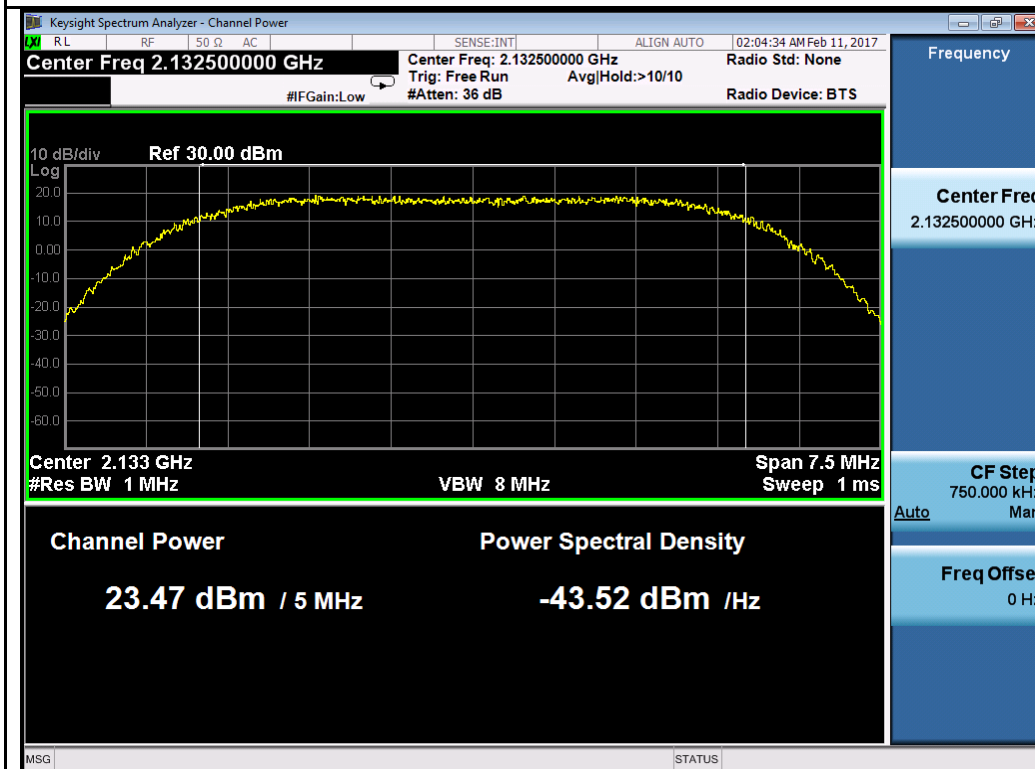

BW 5M QPSK Mid

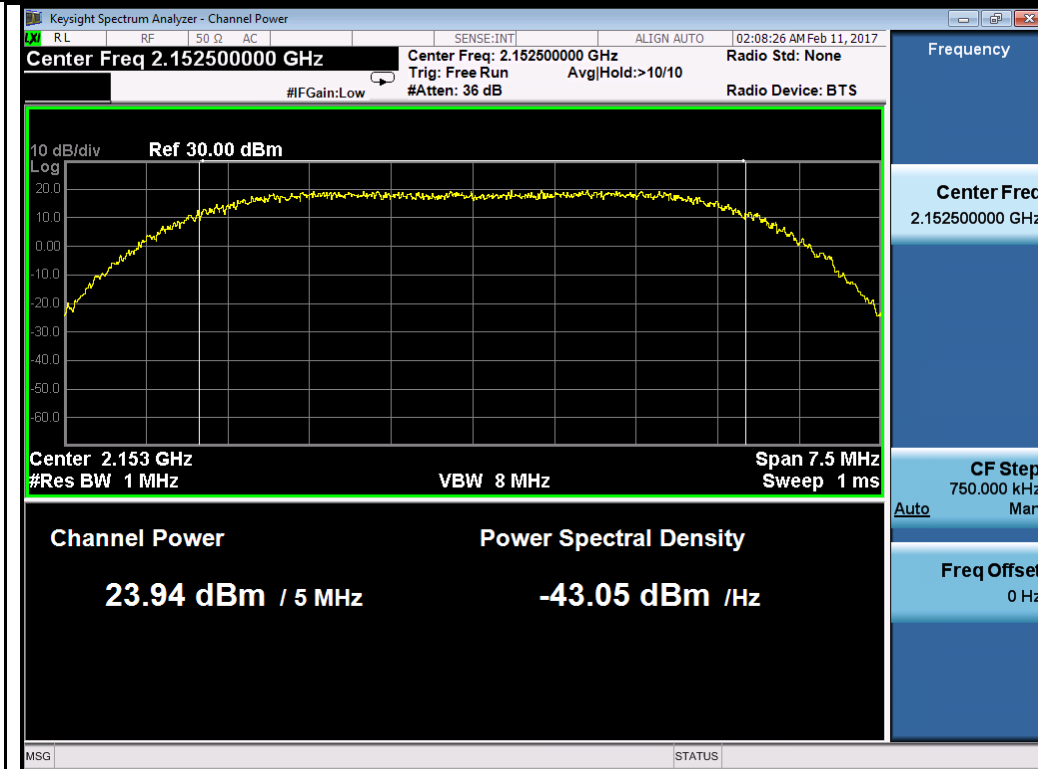

BW 5M QPSK High

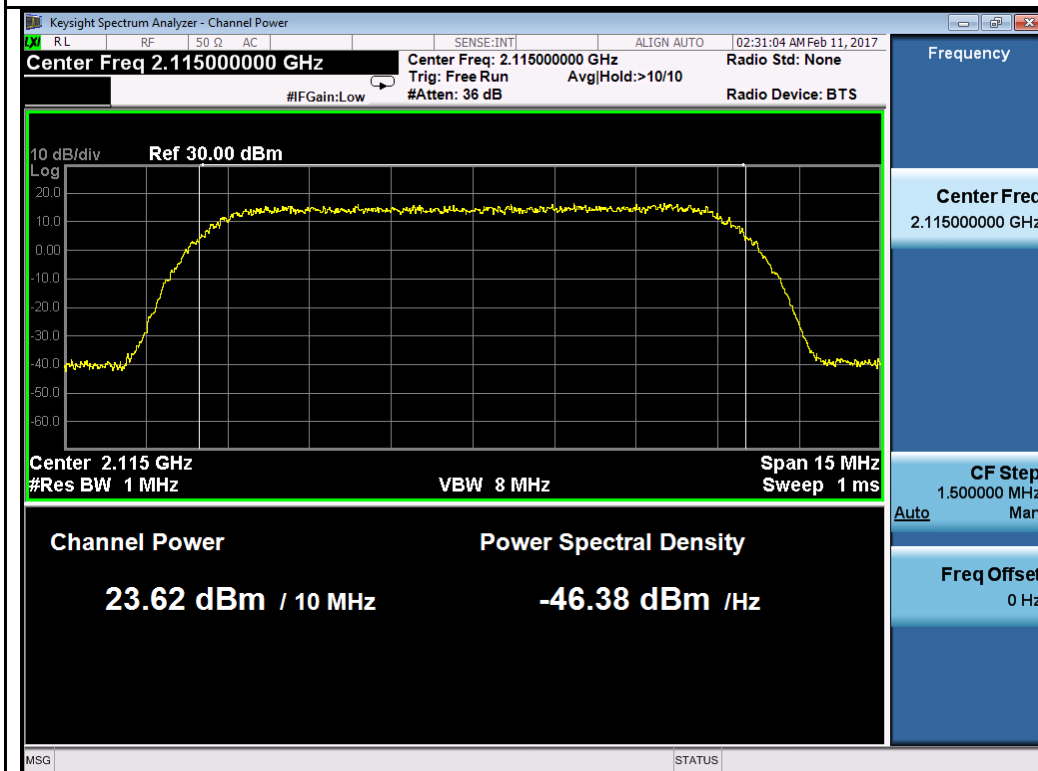

BW 10M QPSK Low

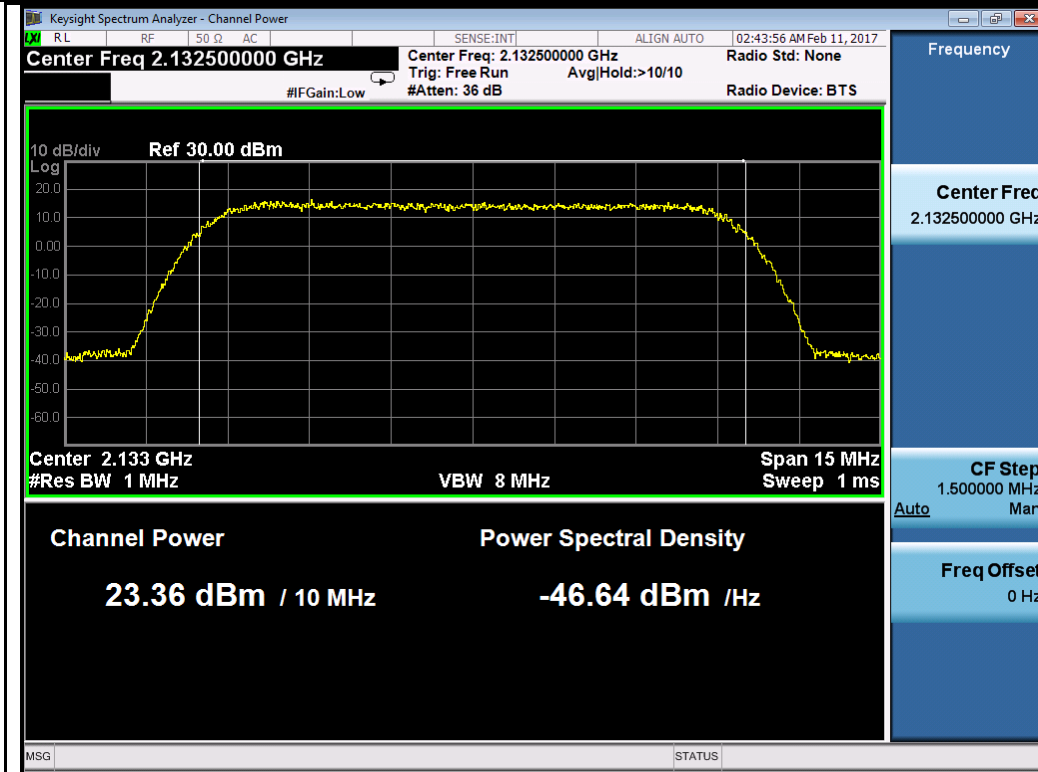

BW 10M QPSK Mid

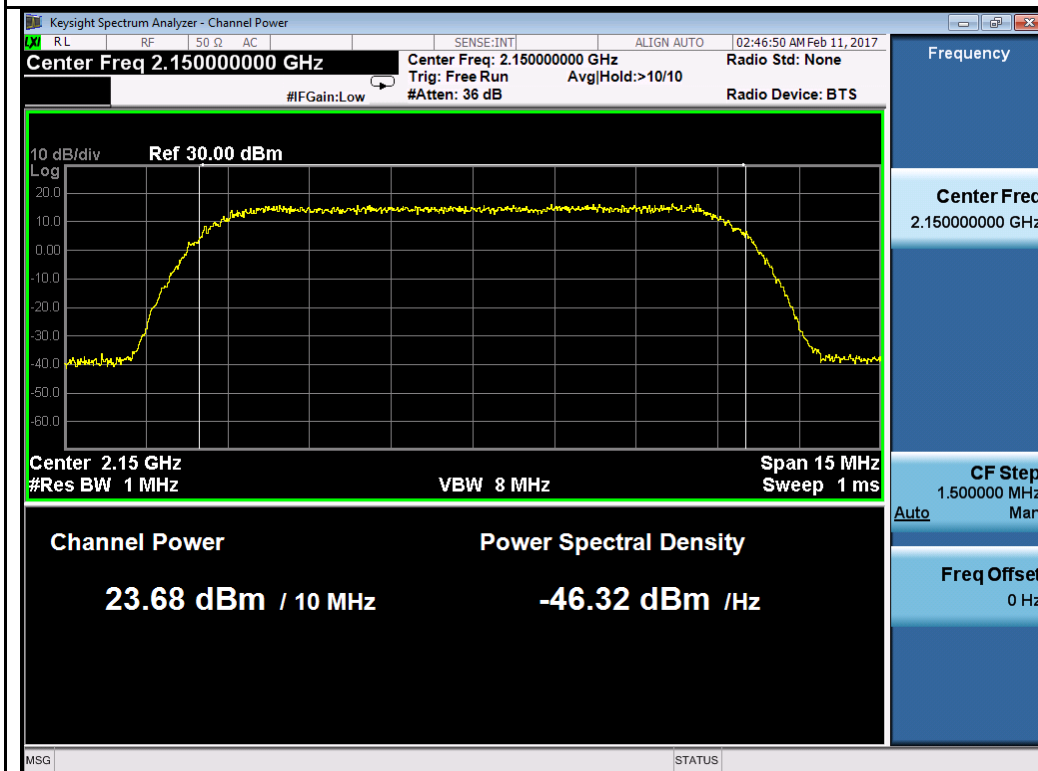

BW 10M QPSK High

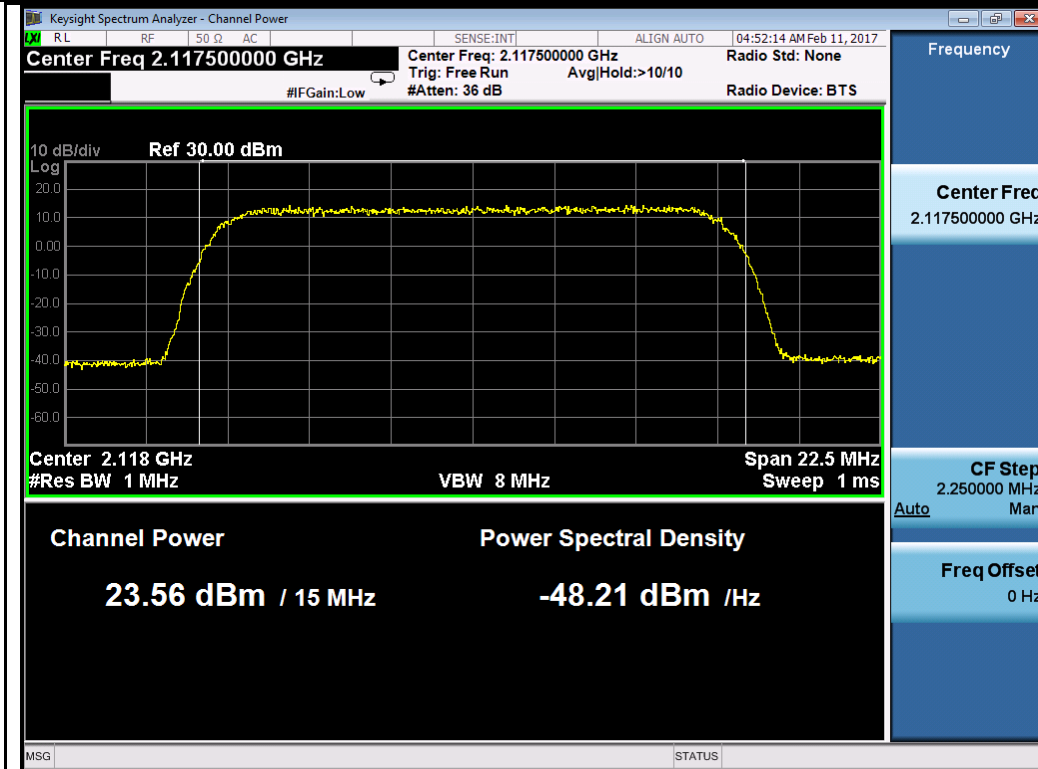

BW 15M QPSK Low

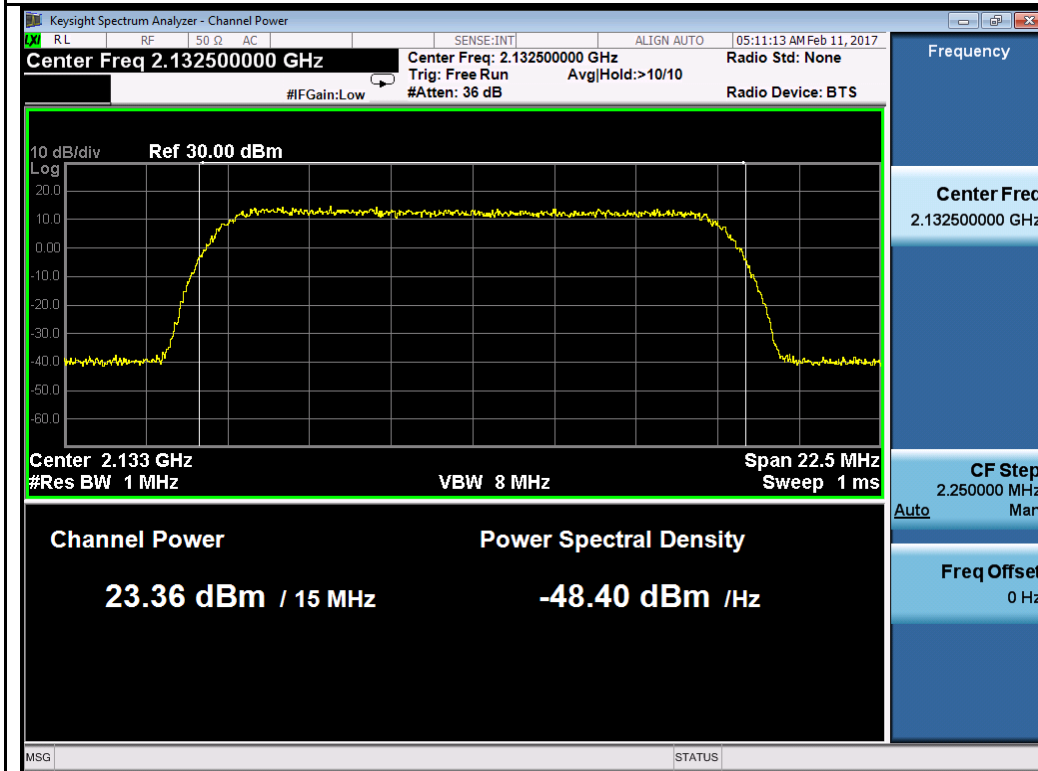

BW 15M QPSK Mid

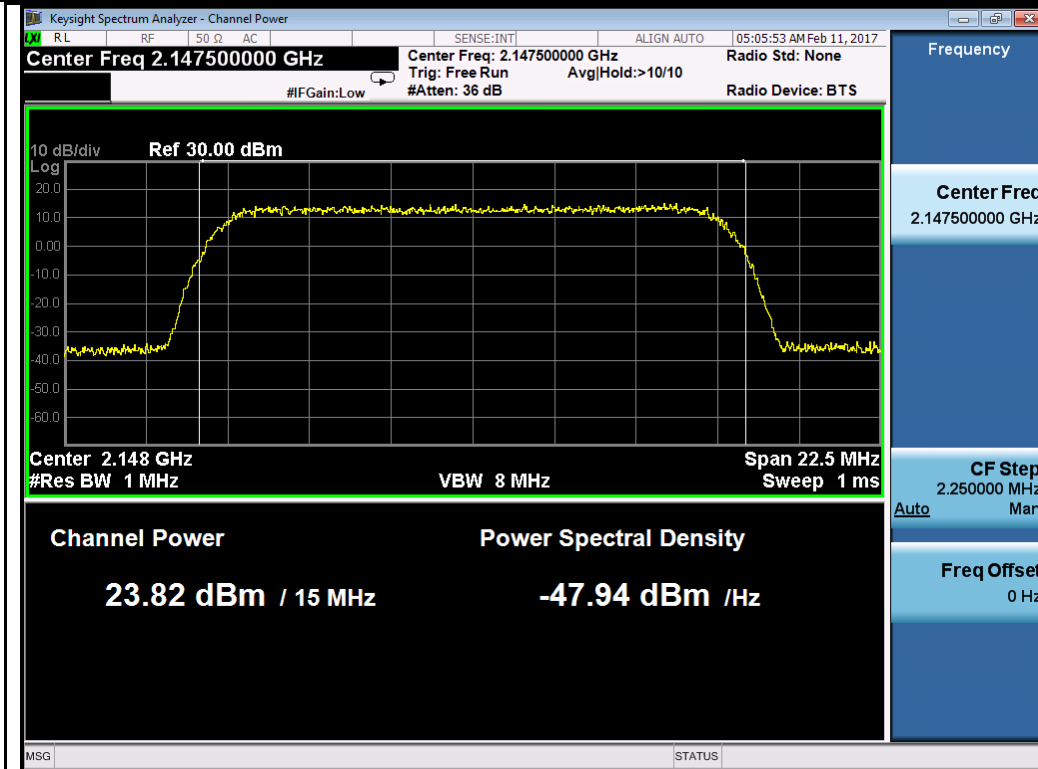

BW 15M QPSK High

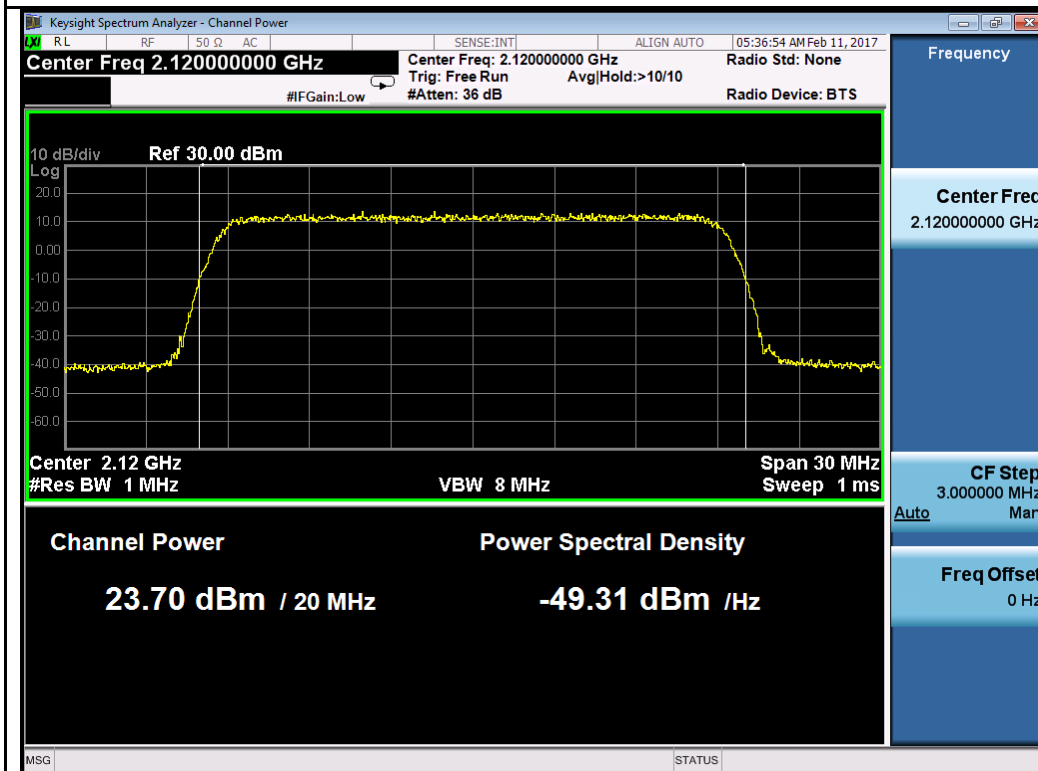

BW 20M QPSK Low

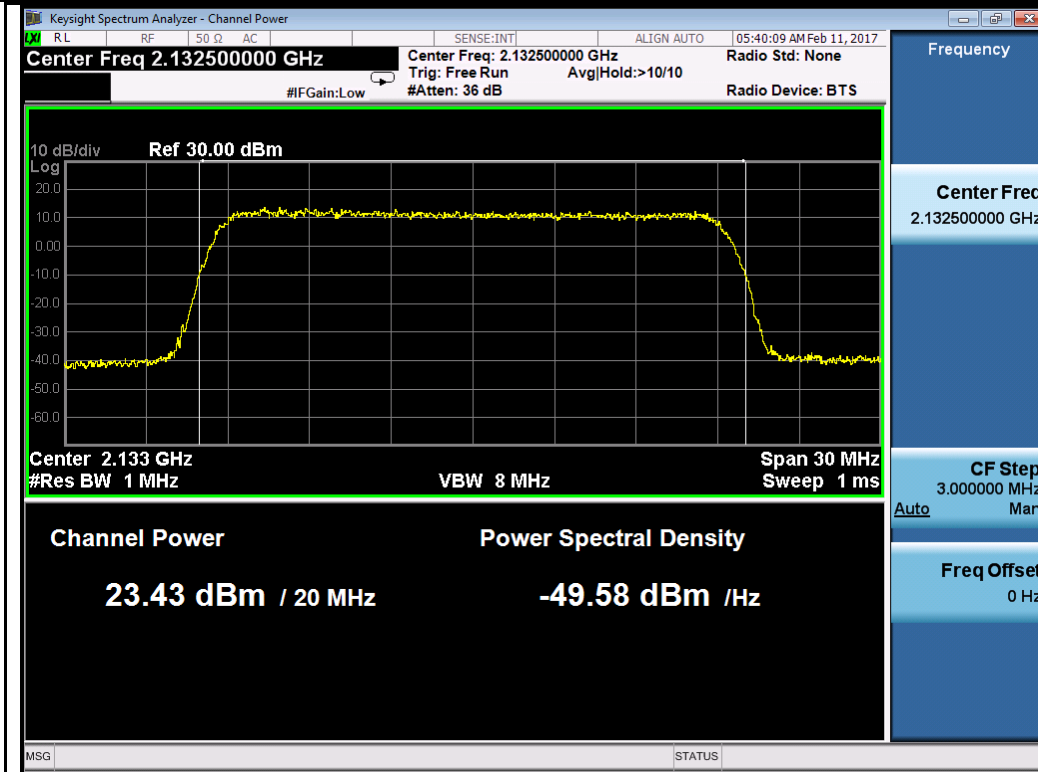

BW 20M QPSK Mid

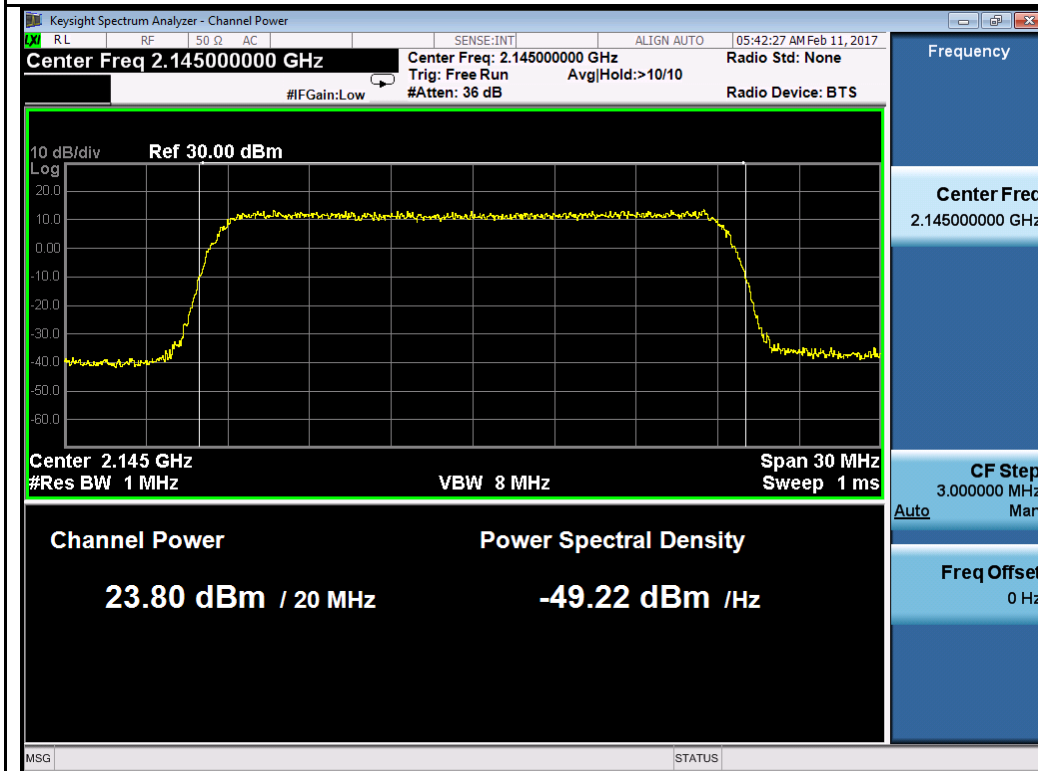

BW 20M QPSK High

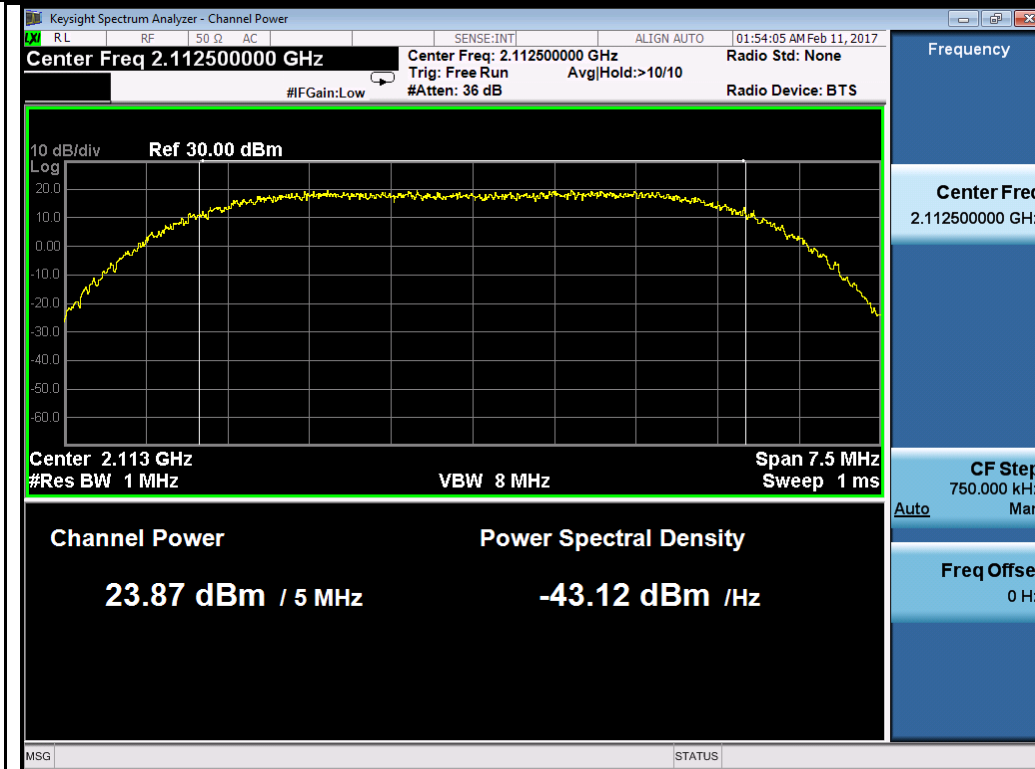

BW 5M 64QAM Low

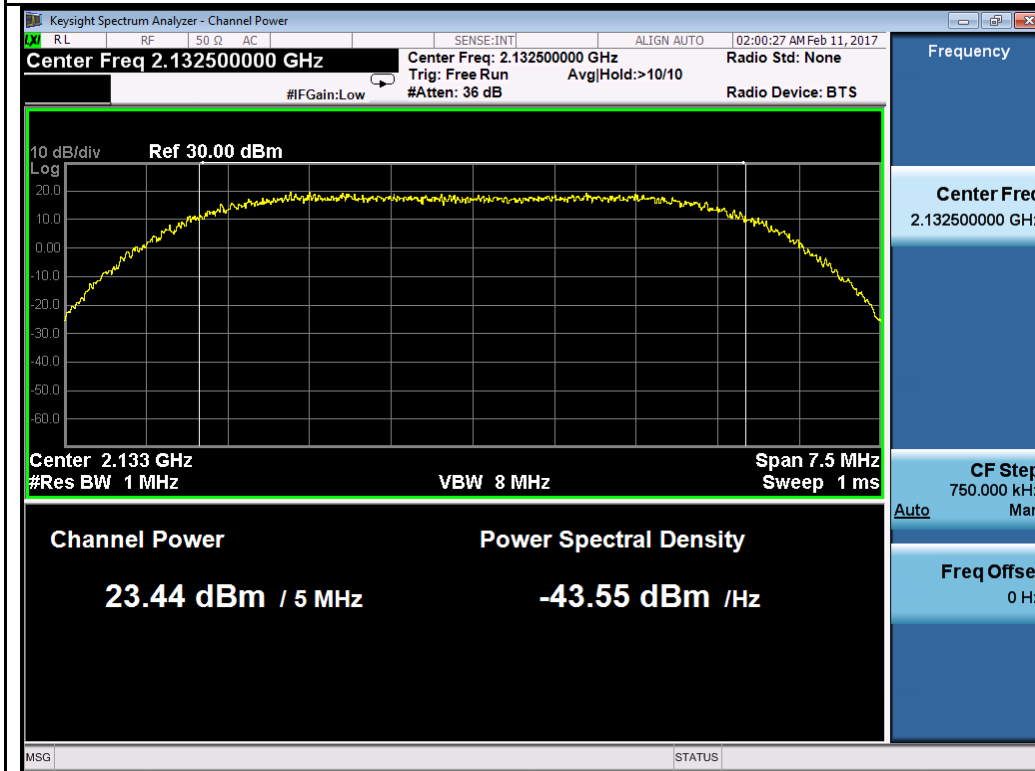

BW 5M 64QAM Mid



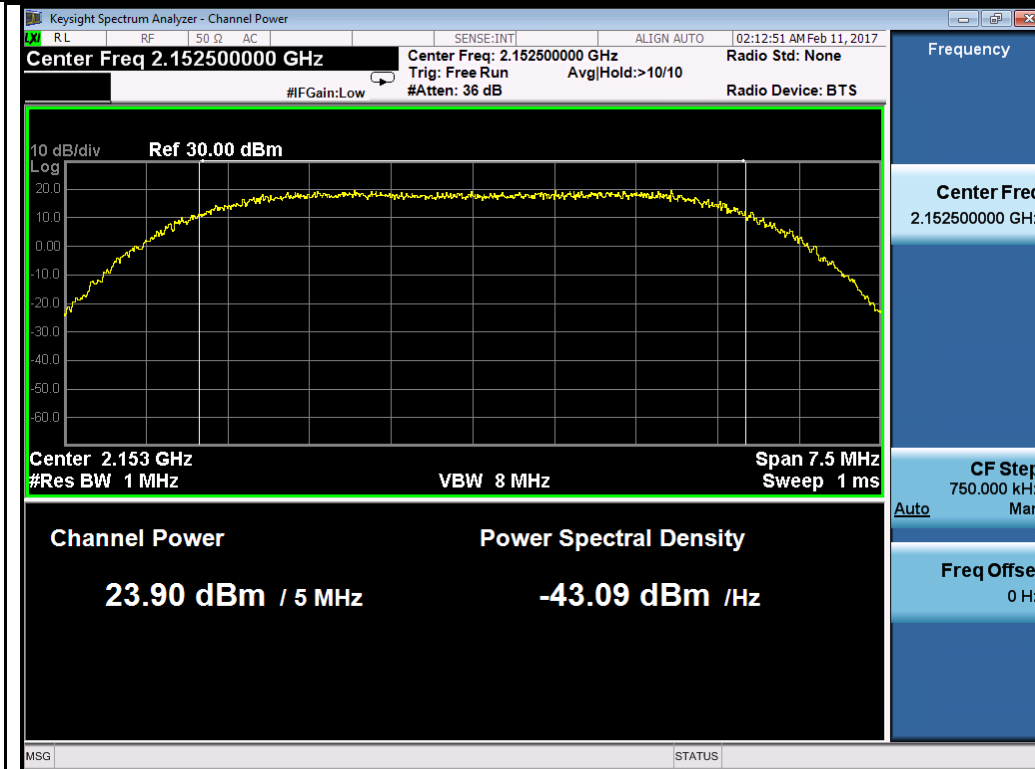

BW 5M 64QAM High

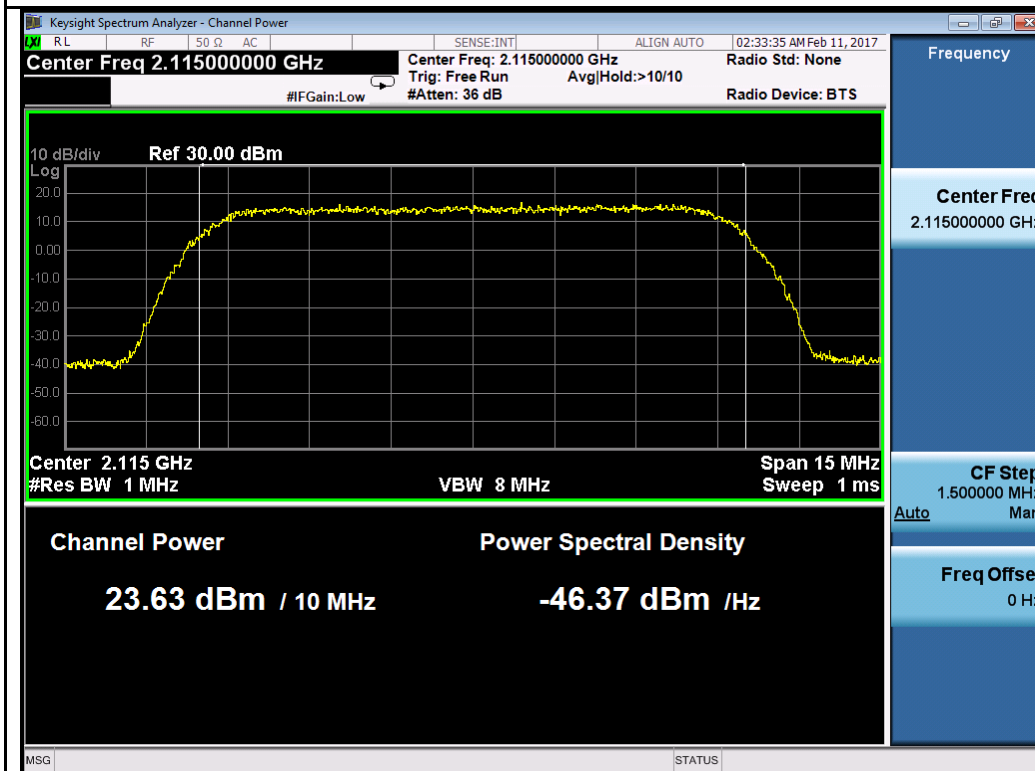

BW 10M 64QAM Low

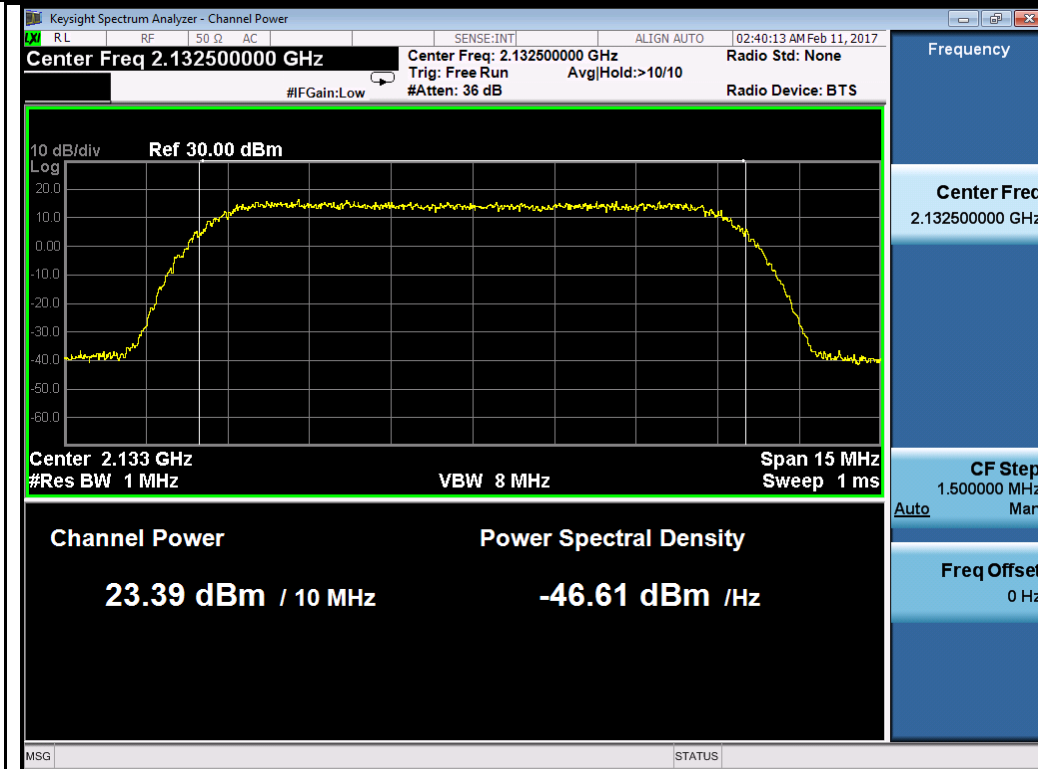

BW 10M 64QAM Mid

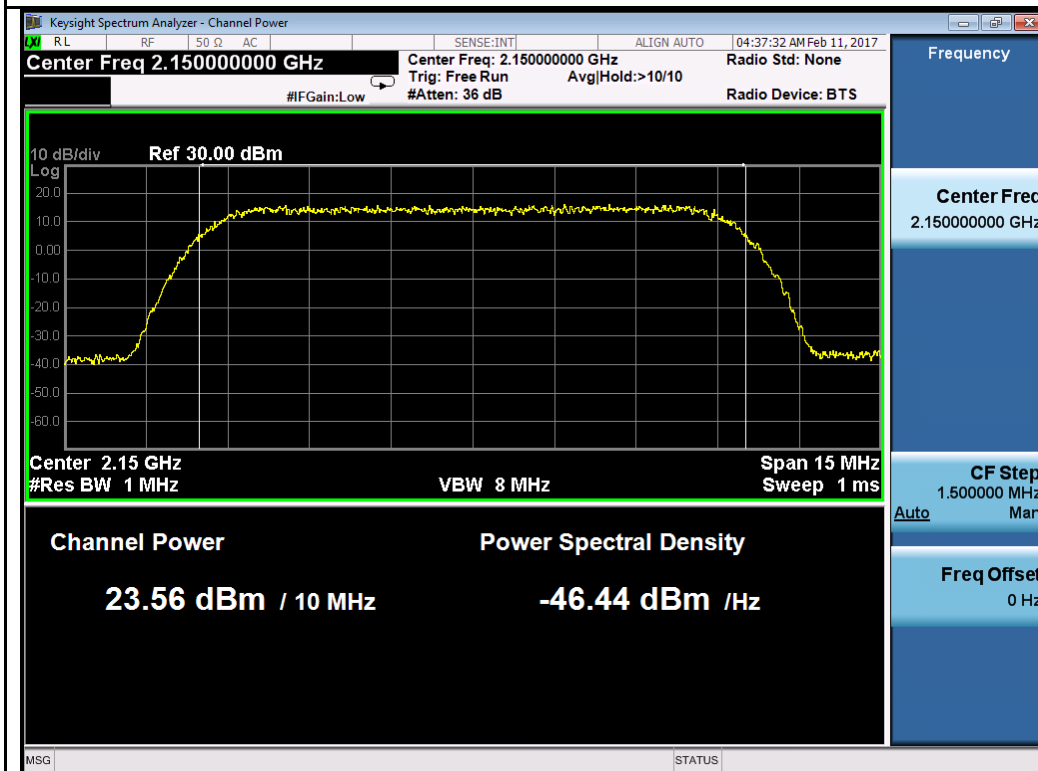

BW 10M 64QAM High

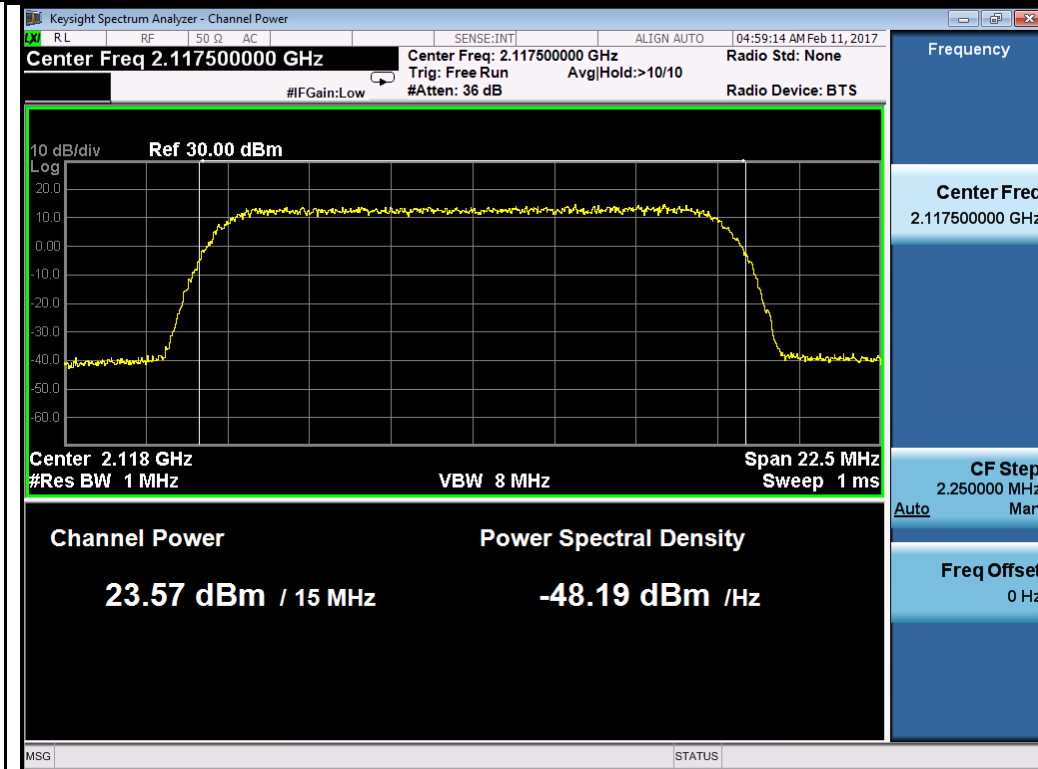

BW 15M 64QAM Low

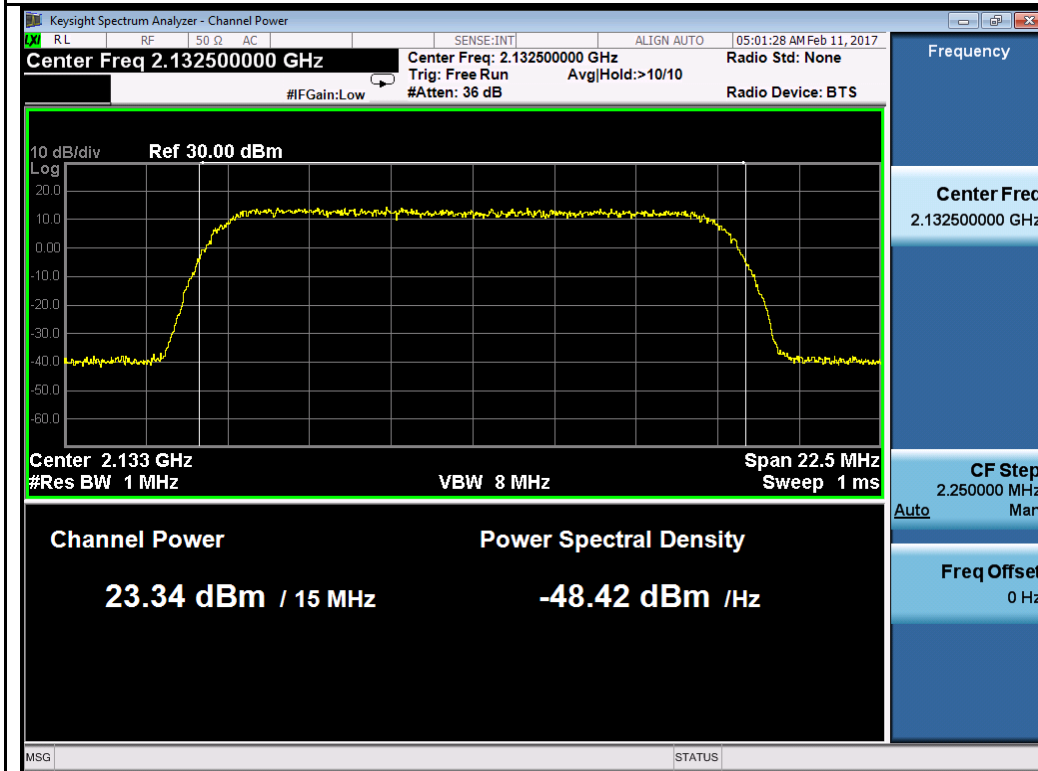

BW 15M 64QAM Mid

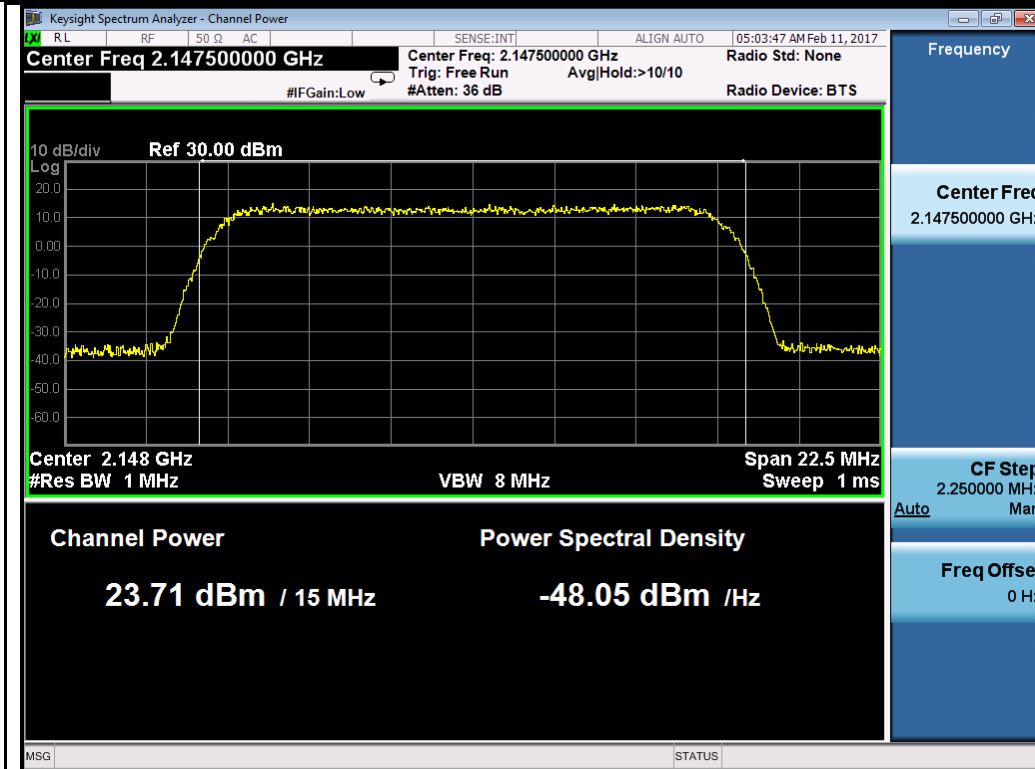

BW 15M 64QAM High

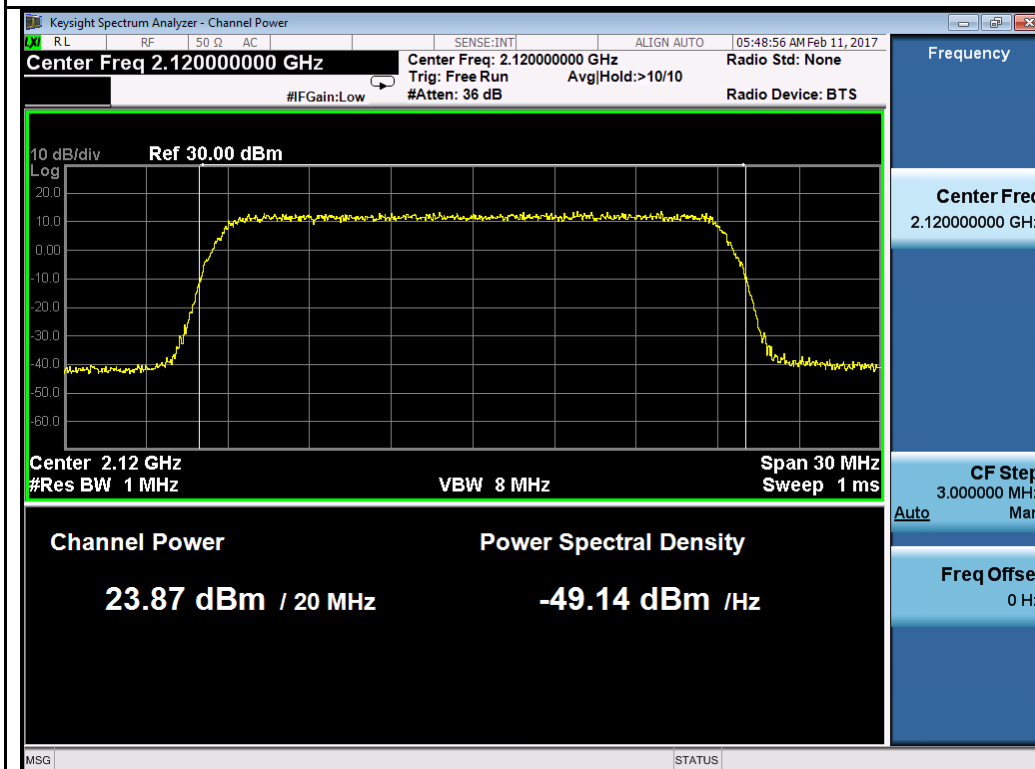

BW 20M 64QAM Low

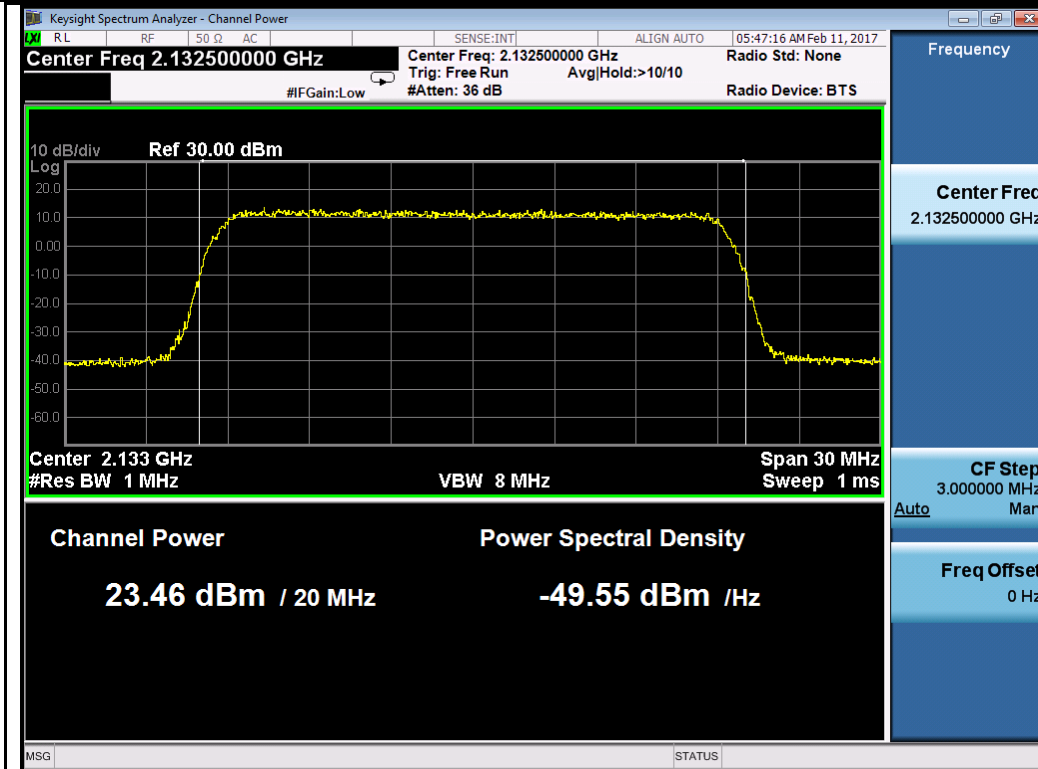

BW 20M 64QAM Mid

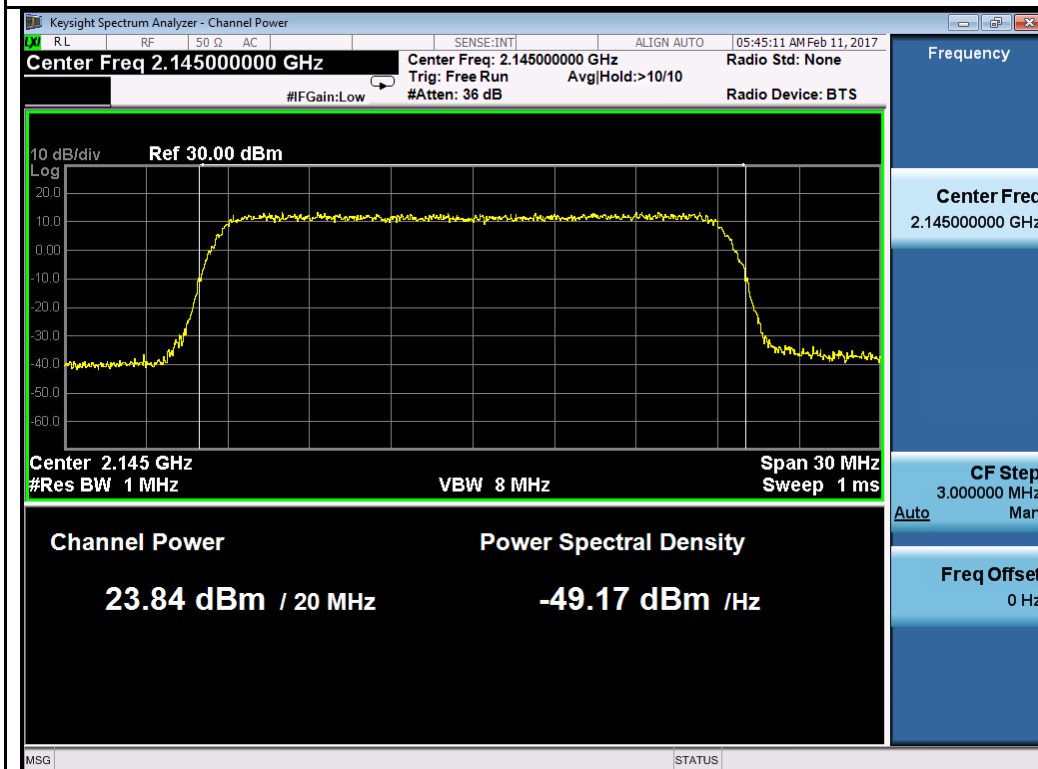

BW 20M 64QAM High

Chain 2:

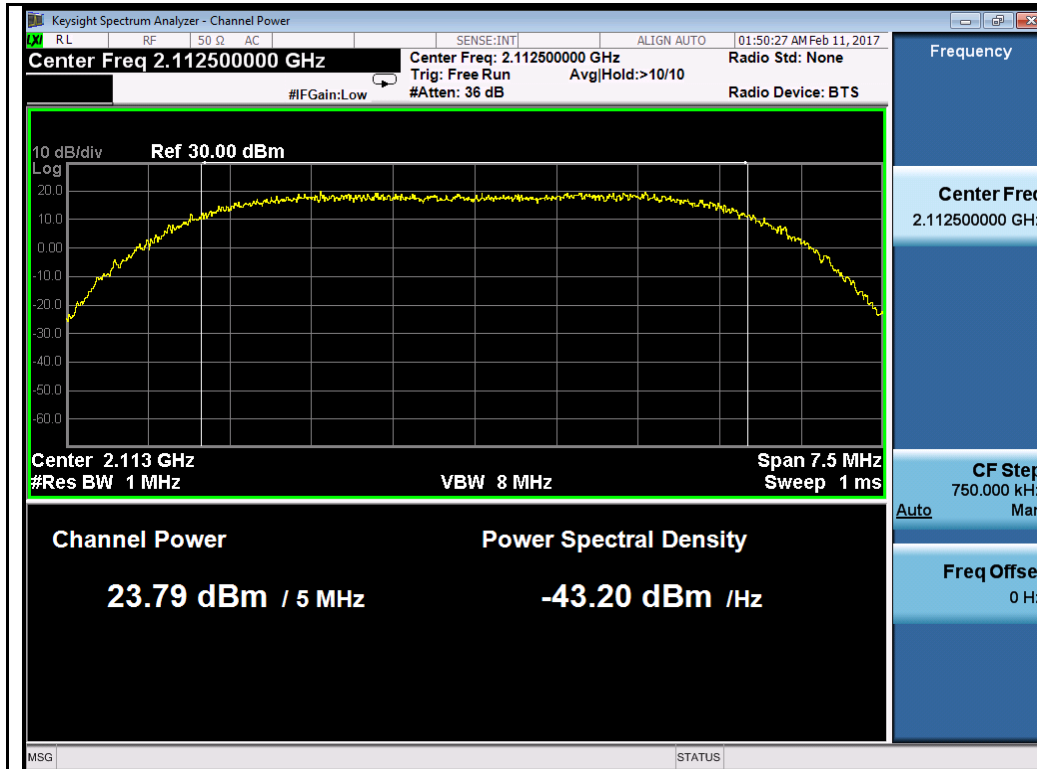

BW 5M QPSK Low

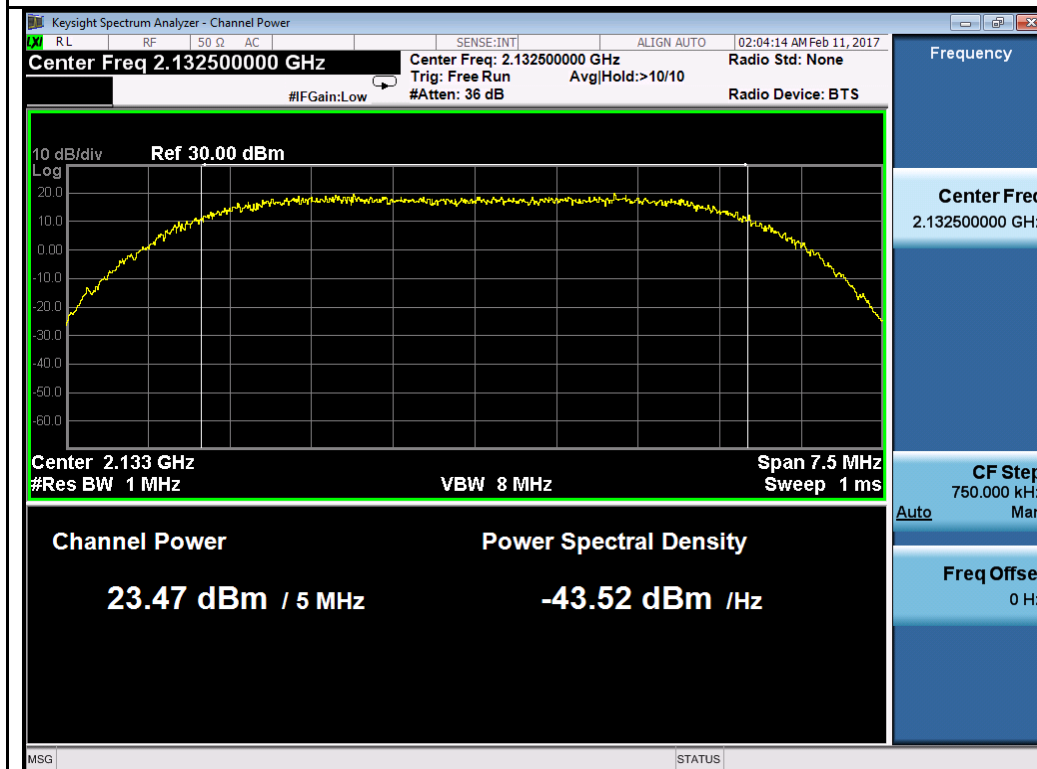

BW 5M QPSK Mid

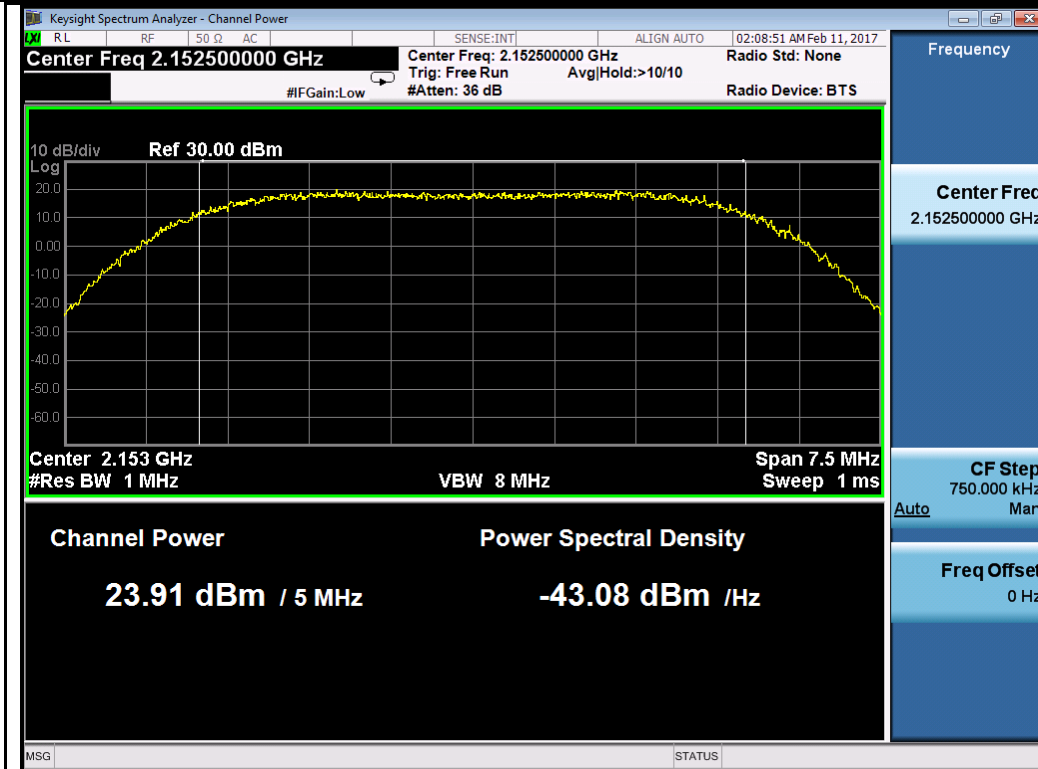

BW 5M QPSK High

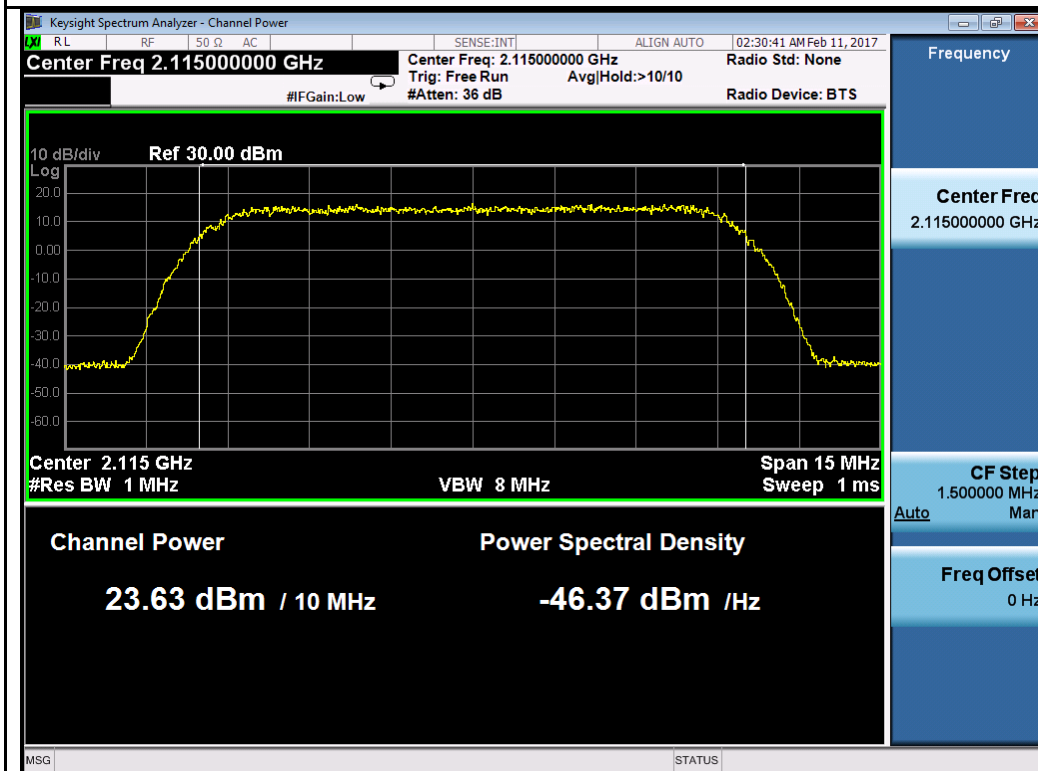

BW 10M QPSK Low

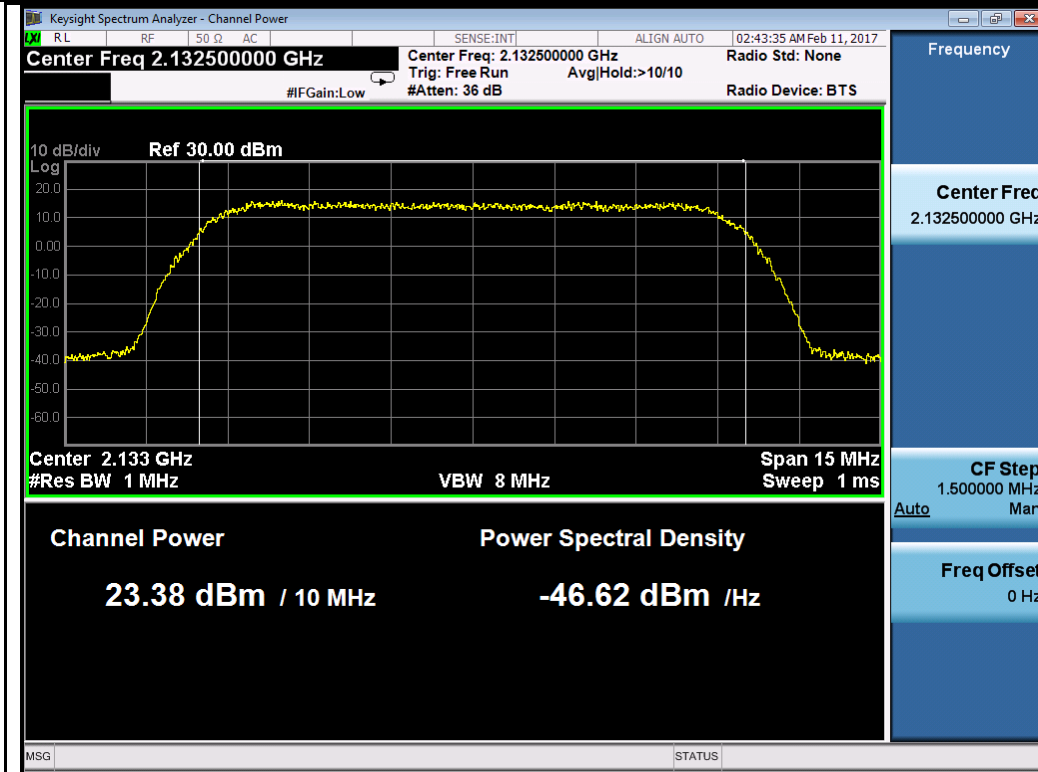

BW 10M QPSK Mid

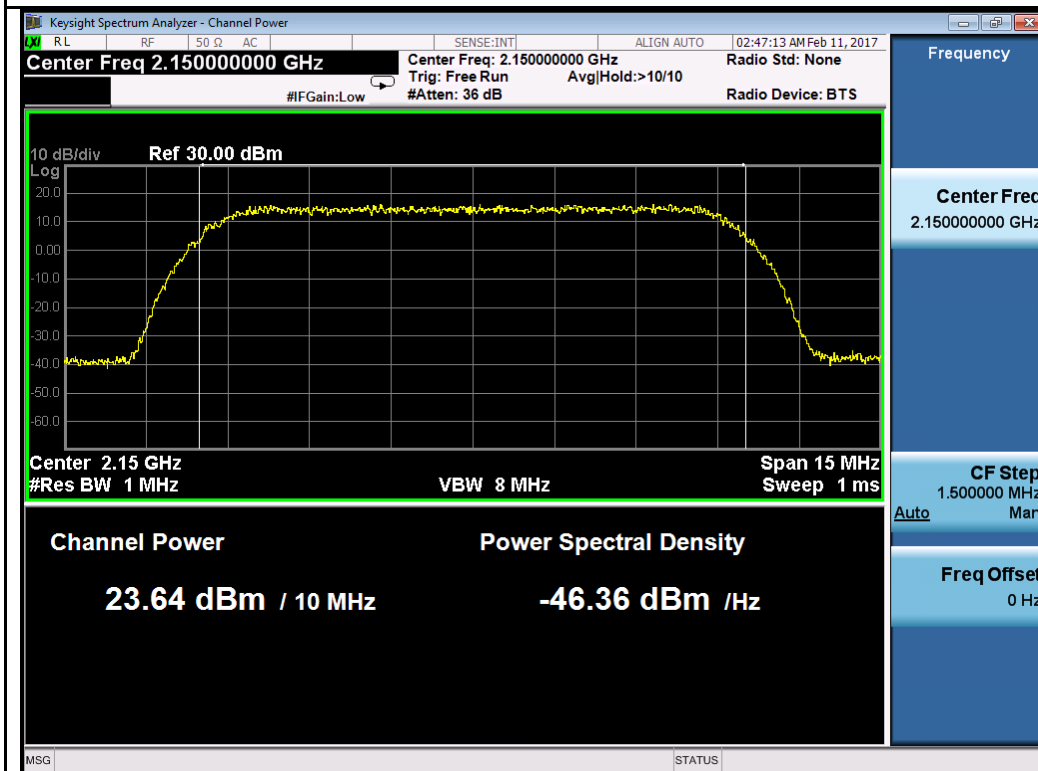

BW 10M QPSK High



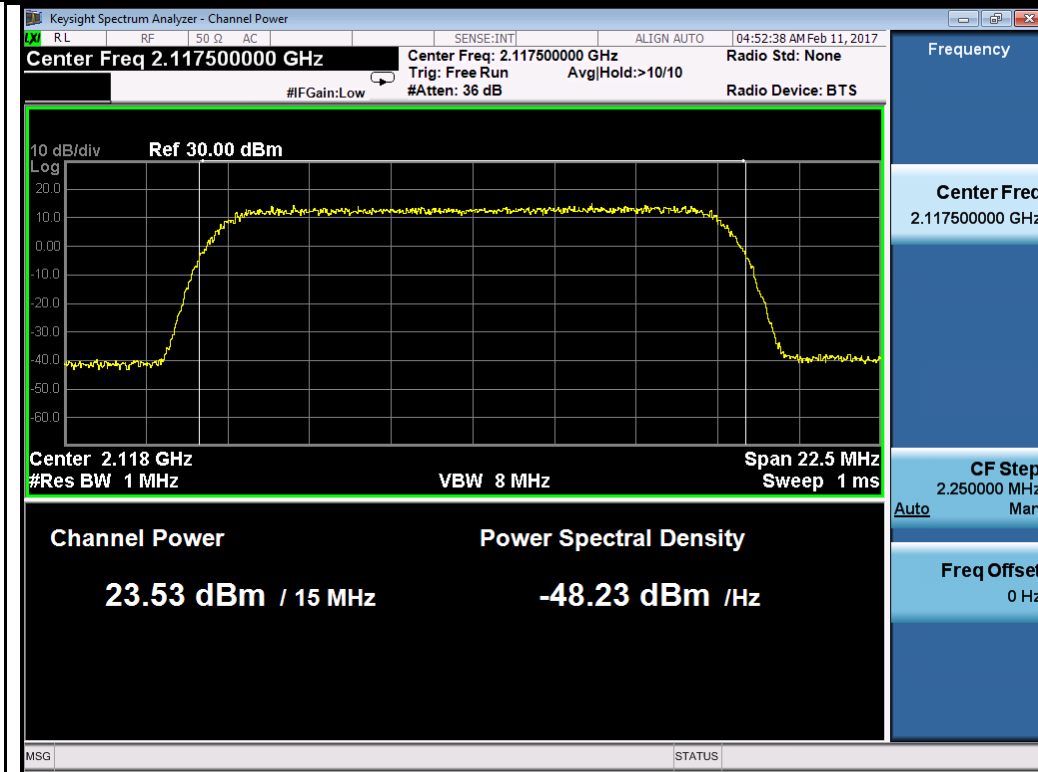

BW 15M QPSK Low

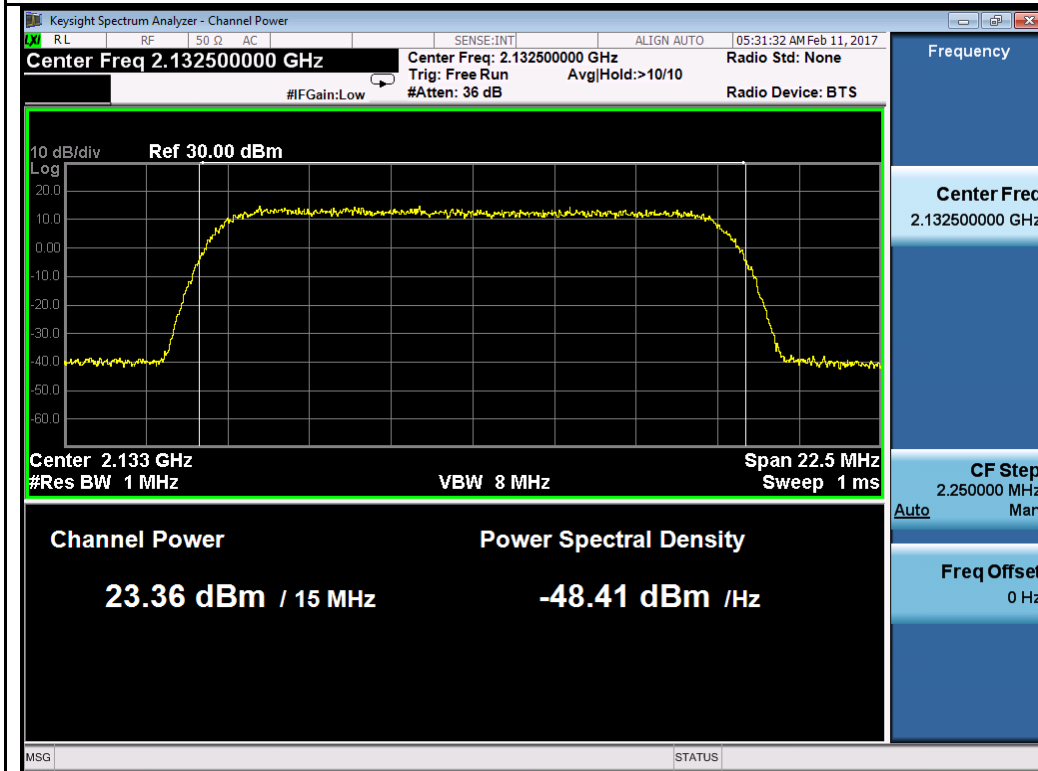

BW 15M QPSK Mid

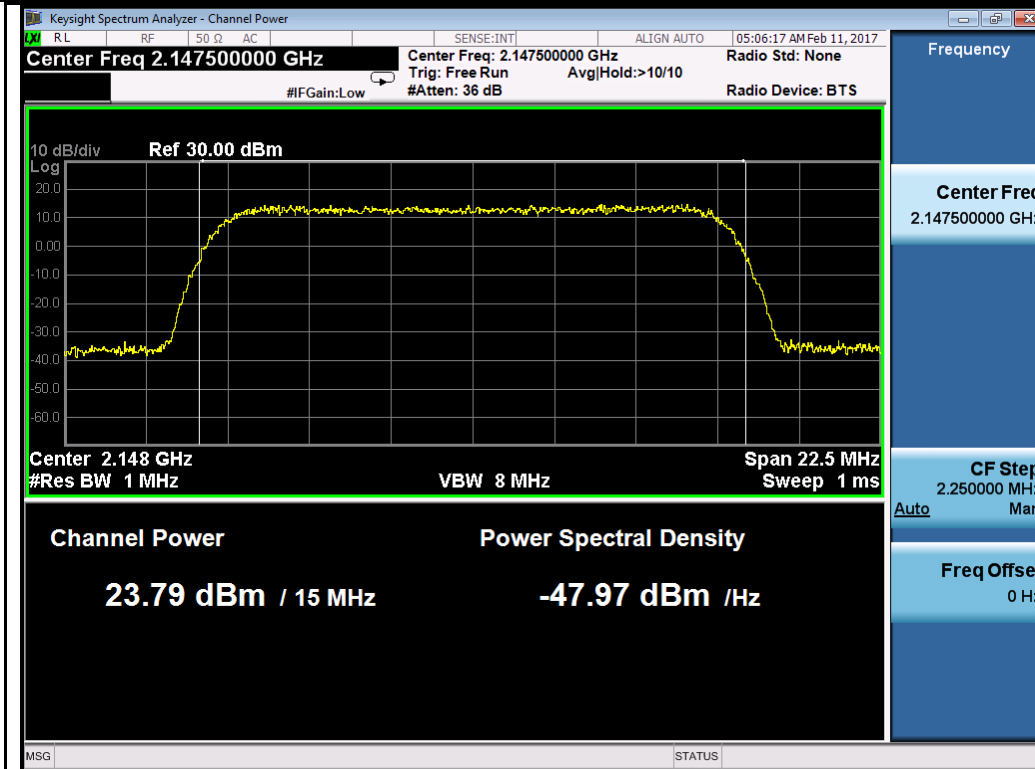

BW 15M QPSK High

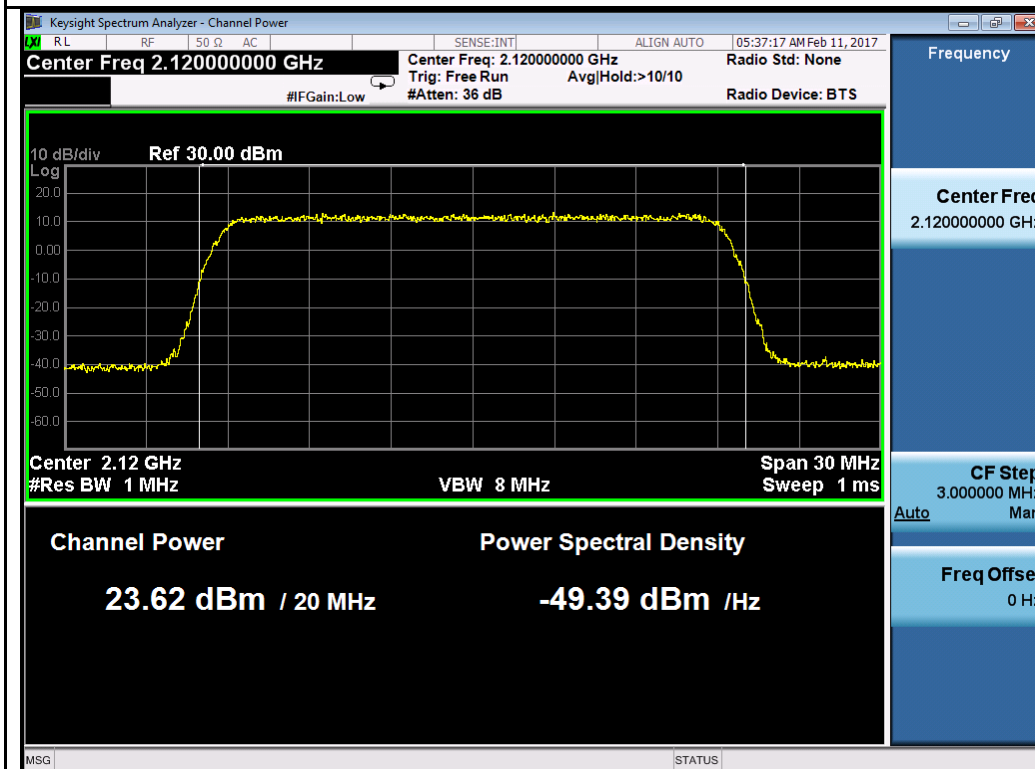

BW 20M QPSK Low

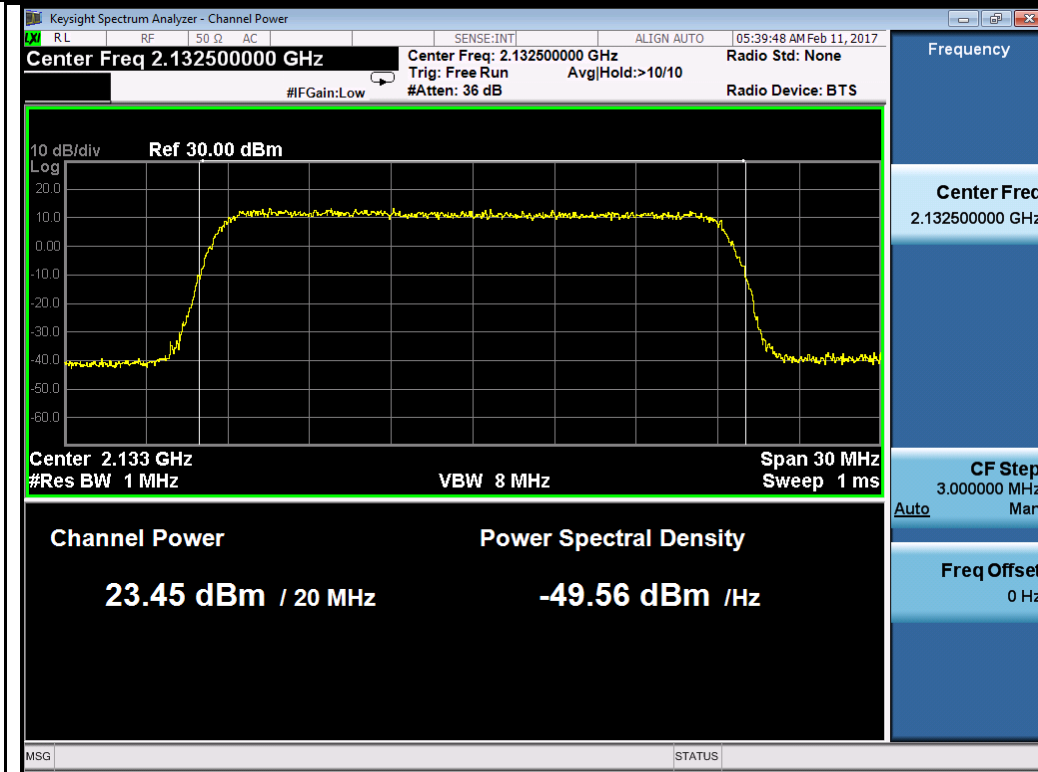

BW 20M QPSK Mid

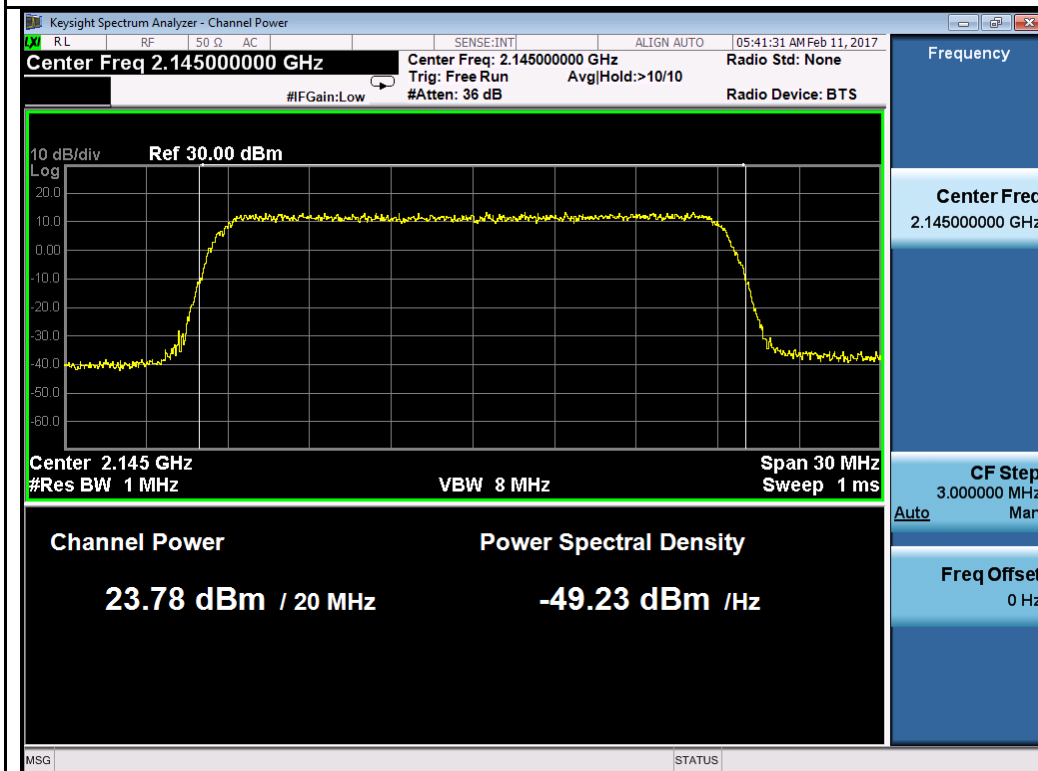

BW 20M QPSK High

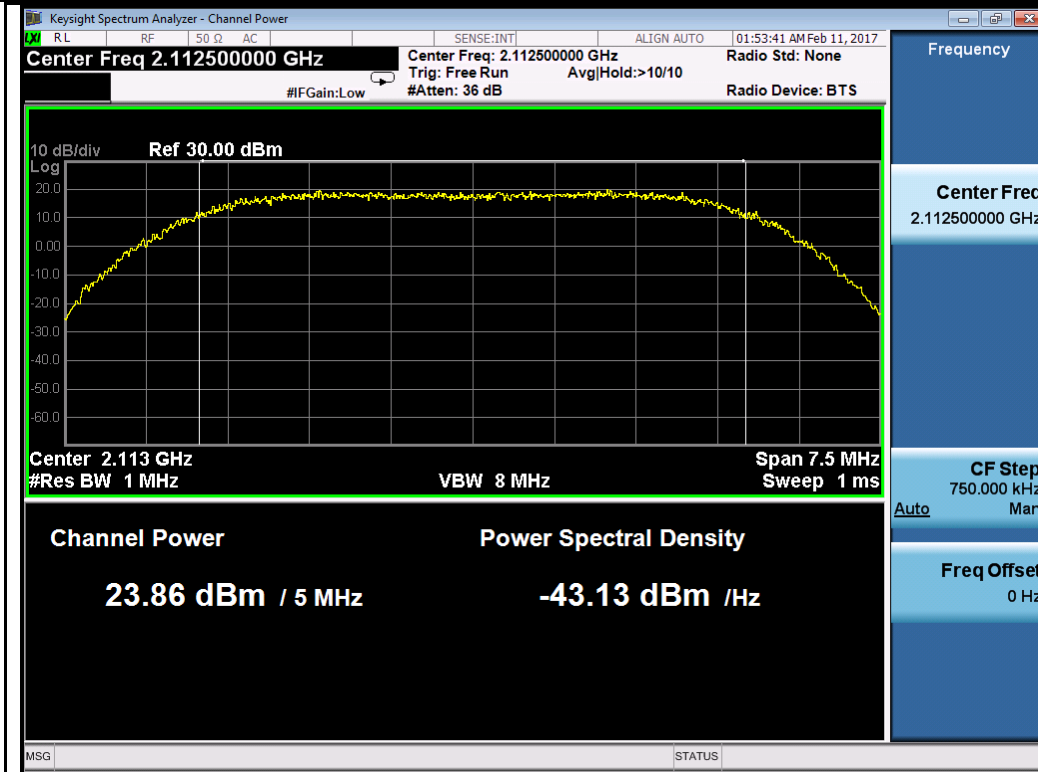

BW 5M 64QAM Low

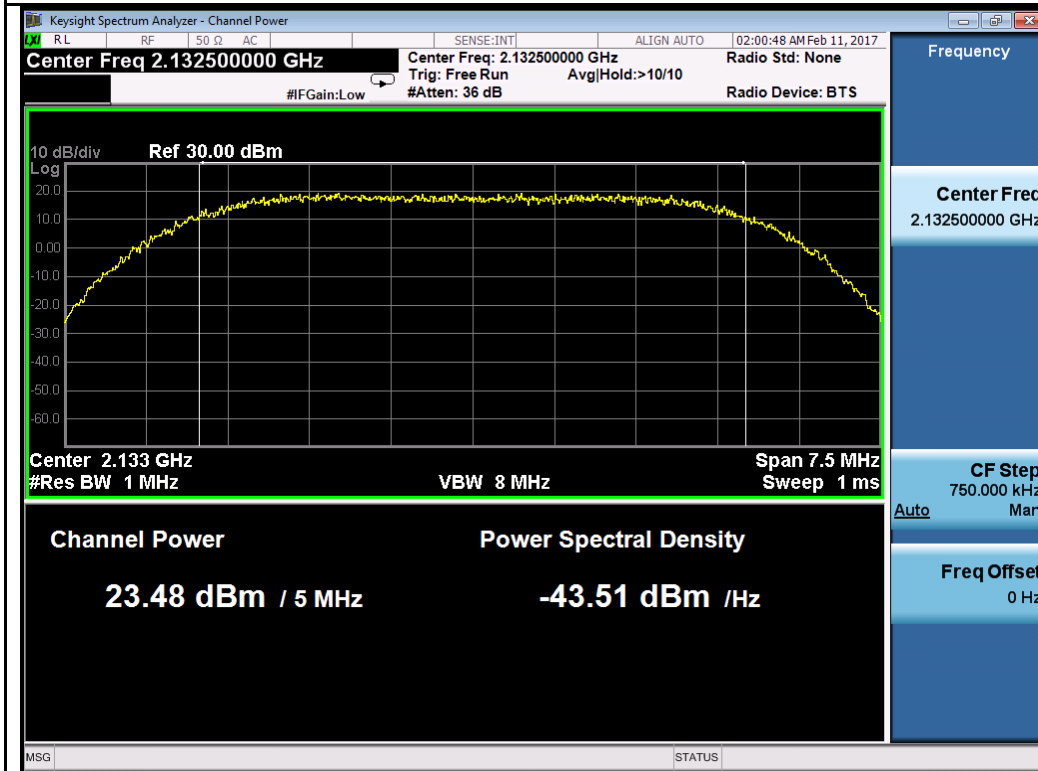

BW 5M 64QAM Mid

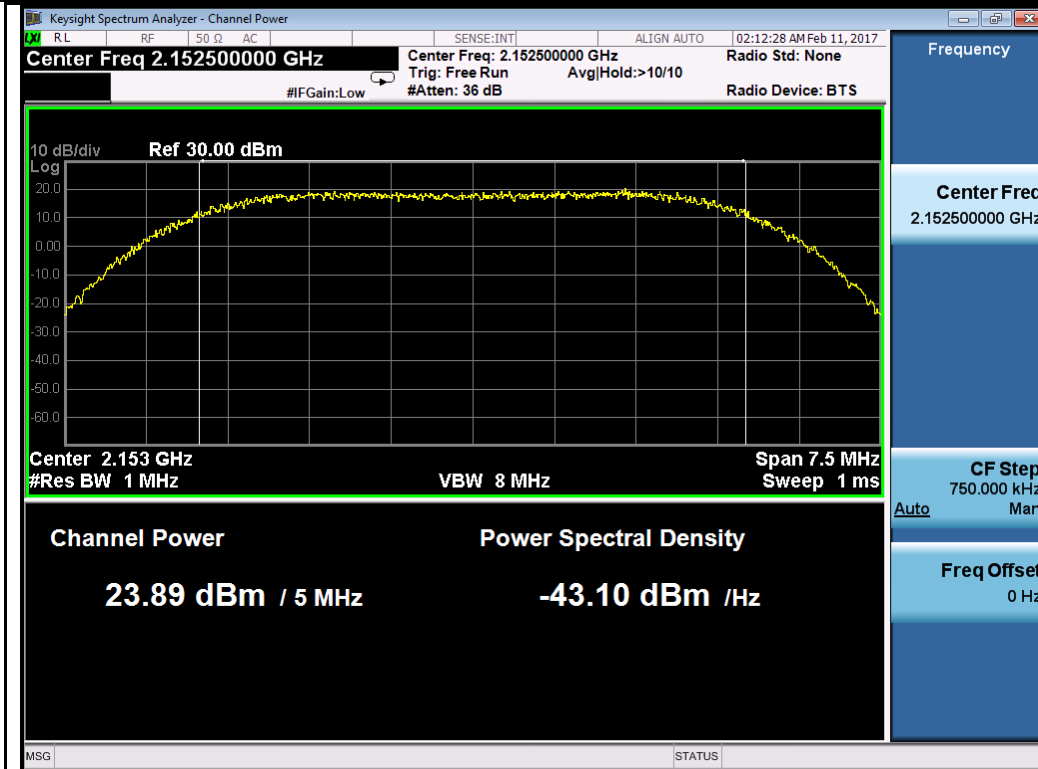

BW 5M 64QAM High

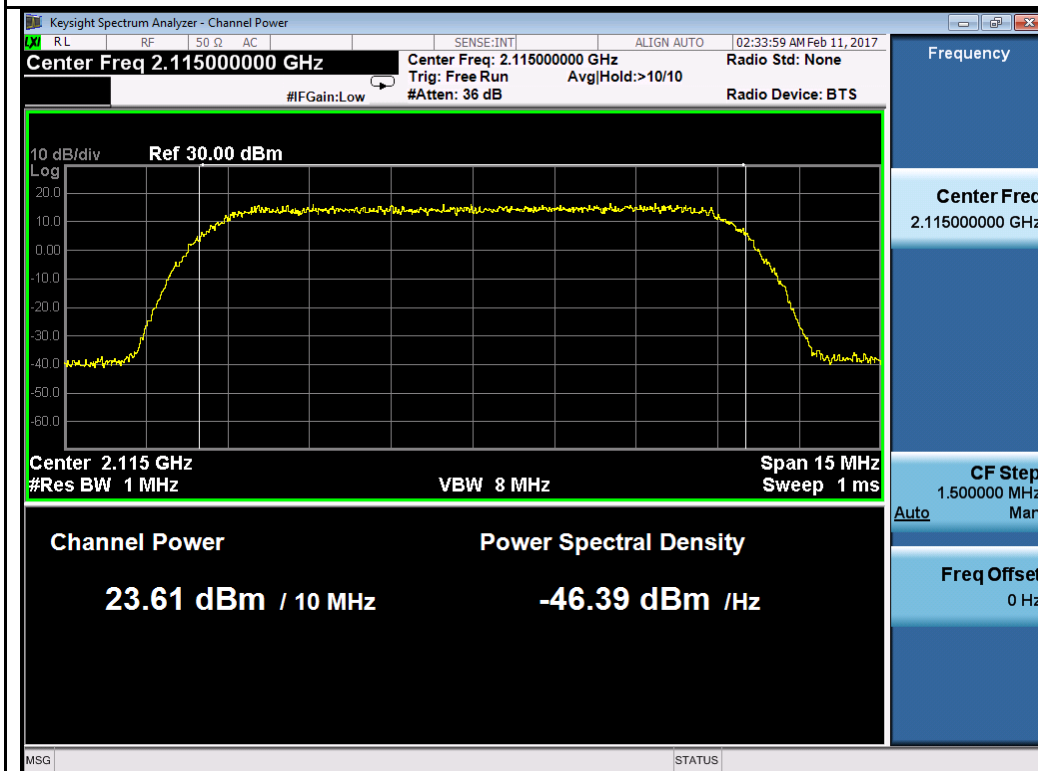

BW 10M 64QAM Low

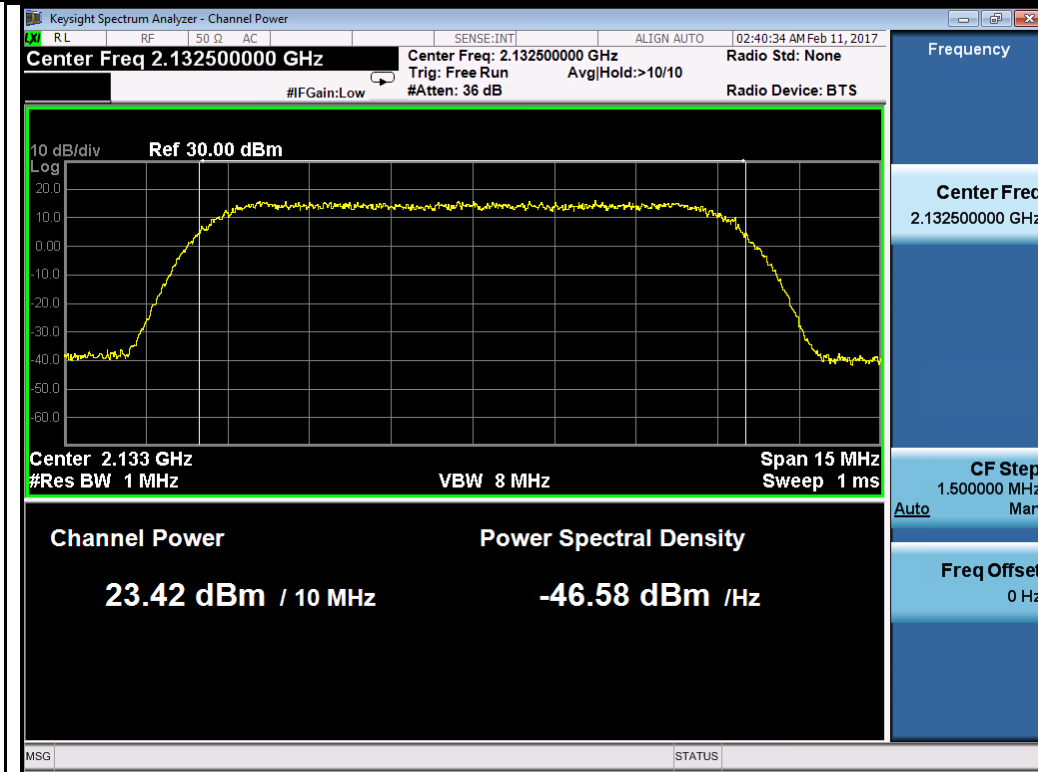

BW 10M 64QAM Mid

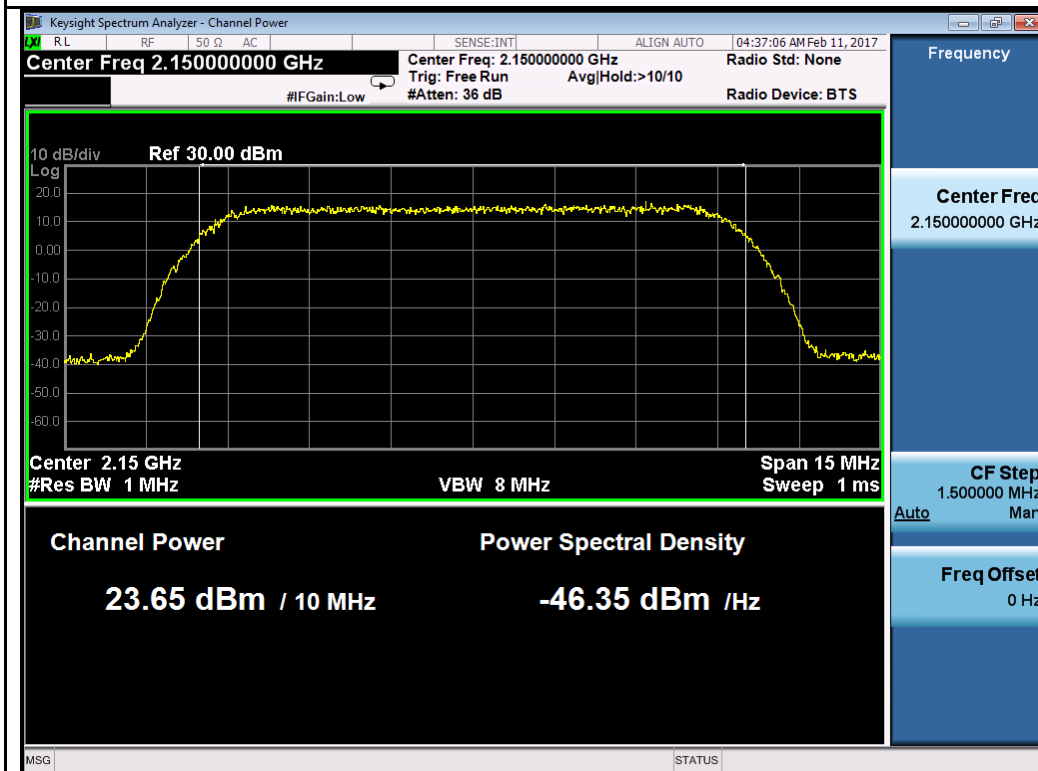

BW 10M 64QAM High

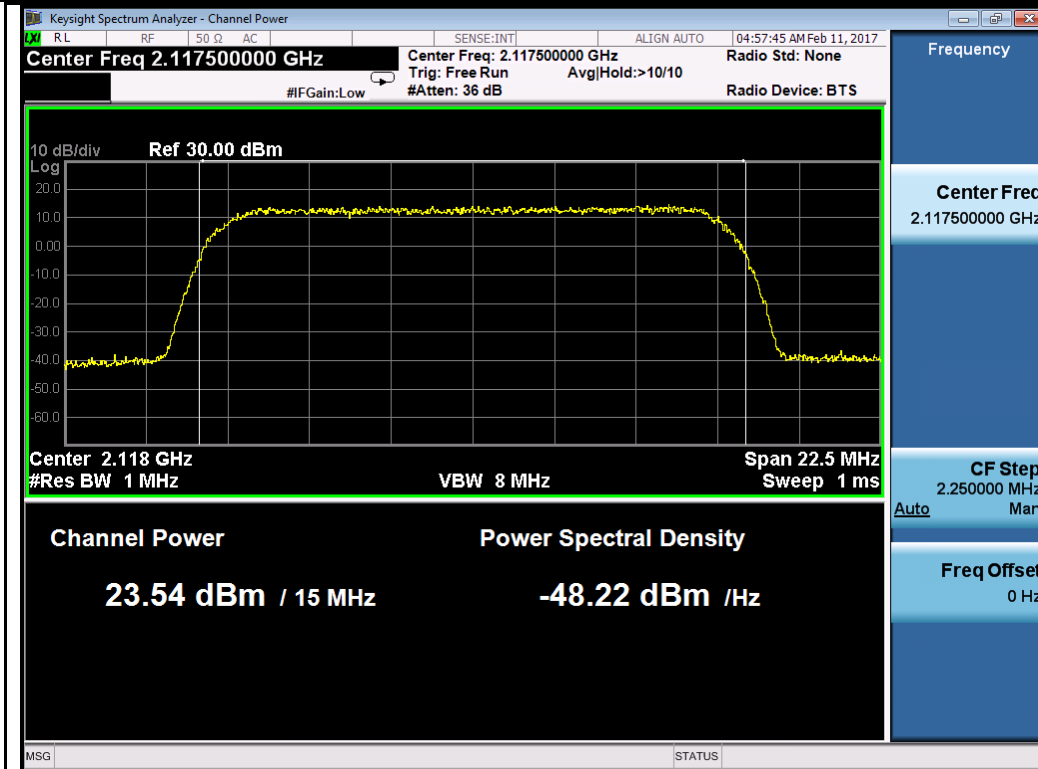

BW 15M 64QAM Low

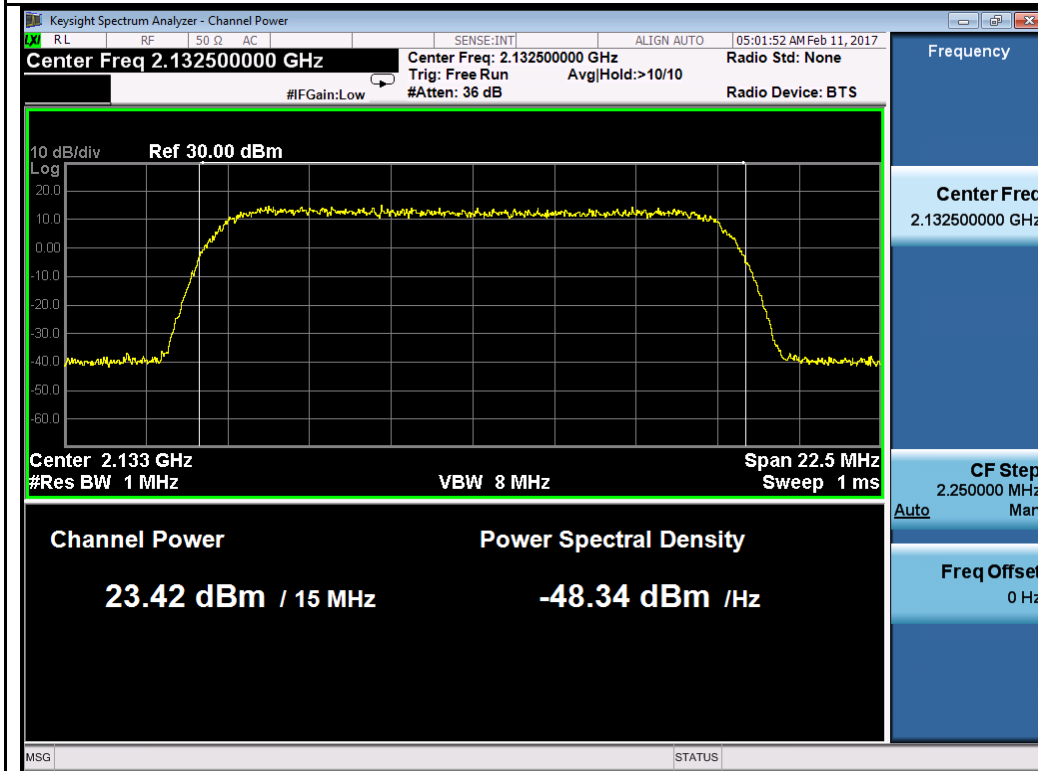

BW 15M 64QAM Mid

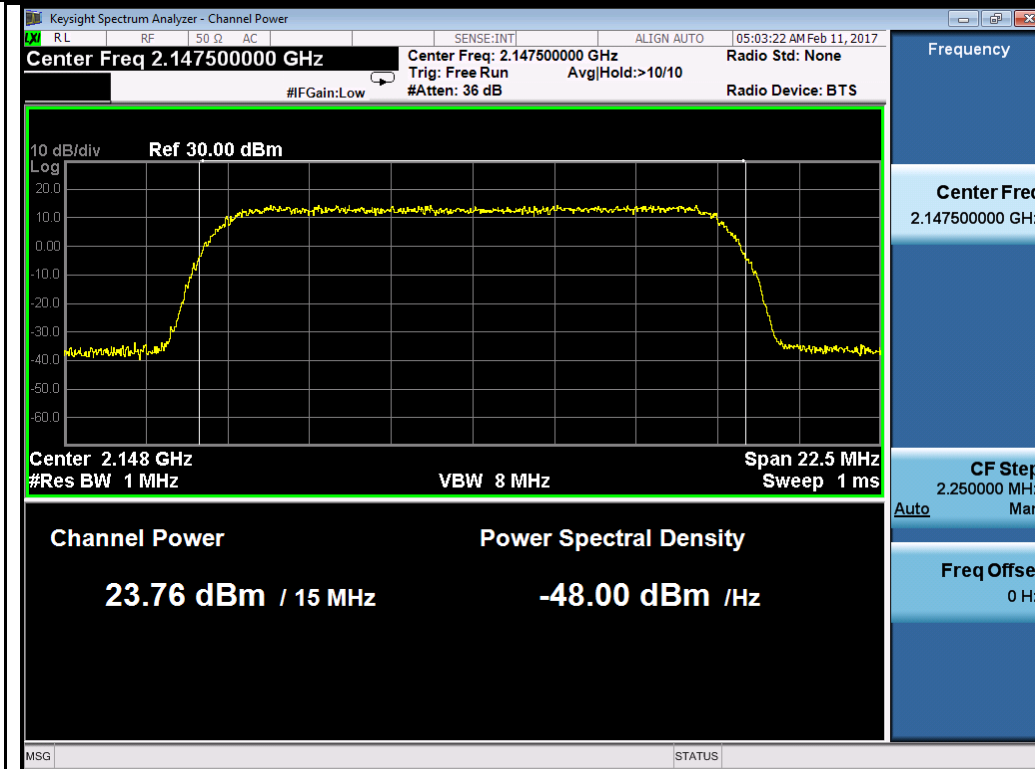

BW 15M 64QAM High

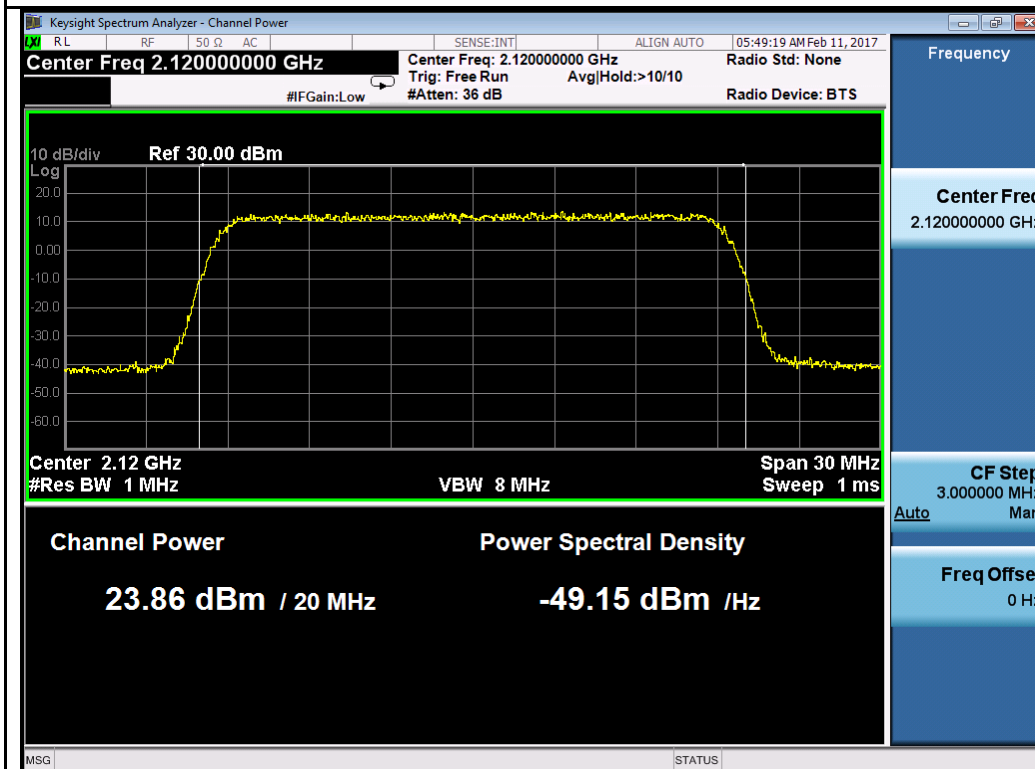

BW 20M 64QAM Low



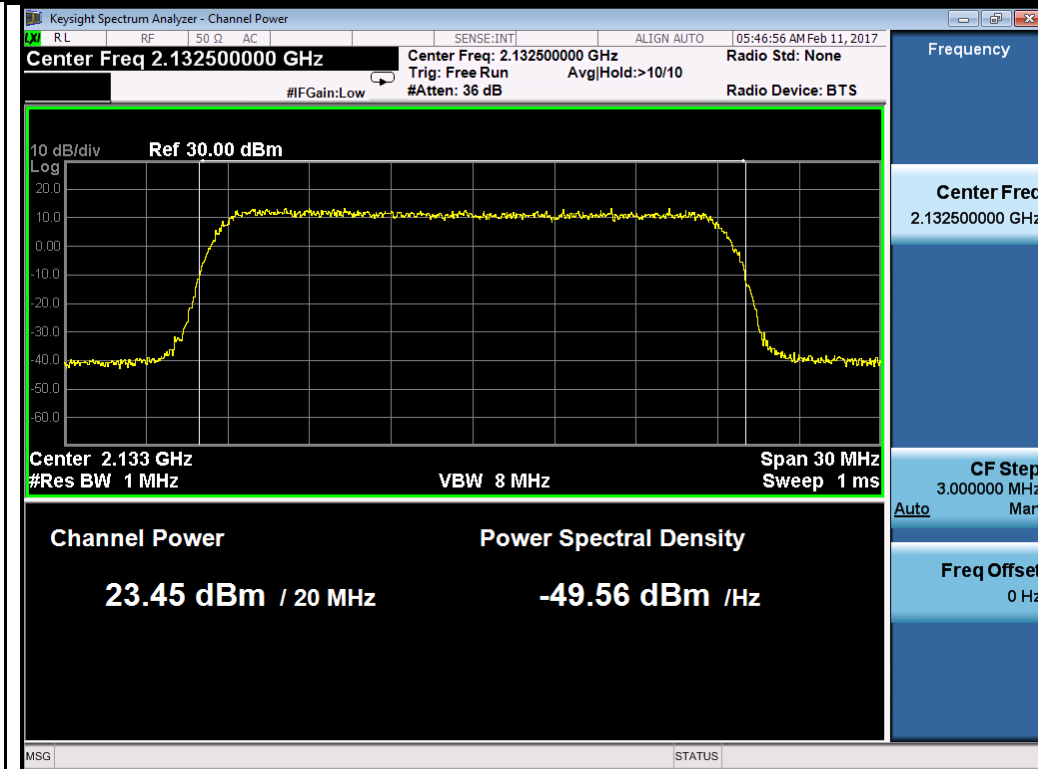

BW 20M 64QAM Mid

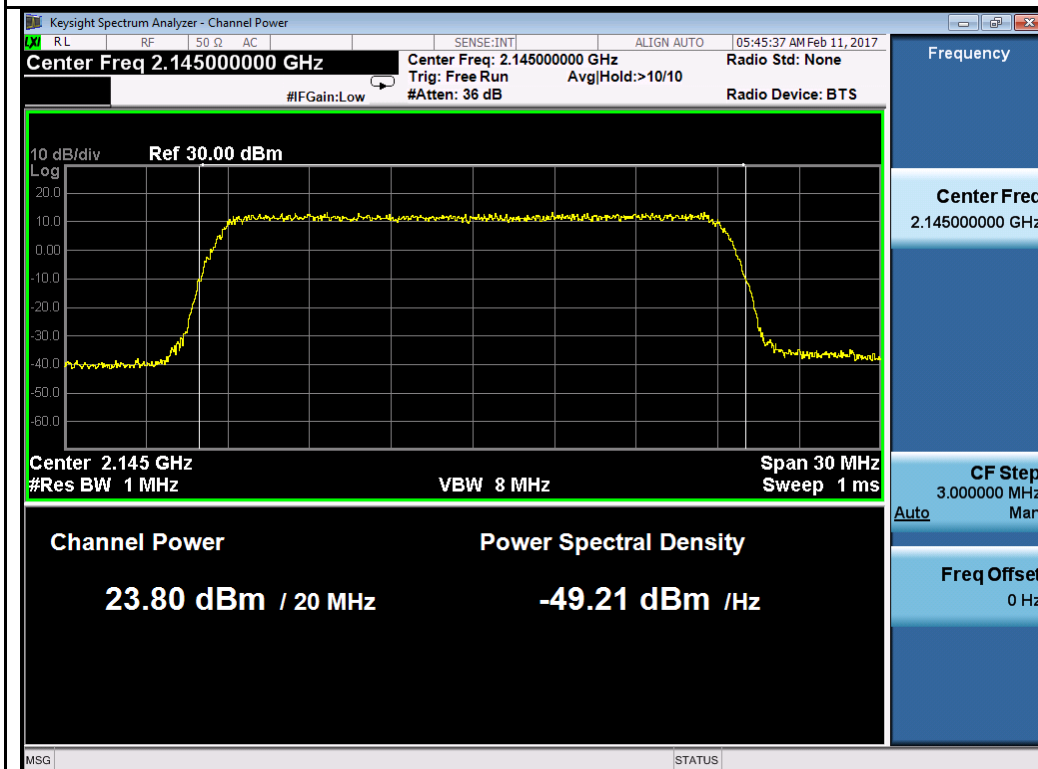

BW 20M 64QAM High

Test Plots for LTE band 66:

Chain1:



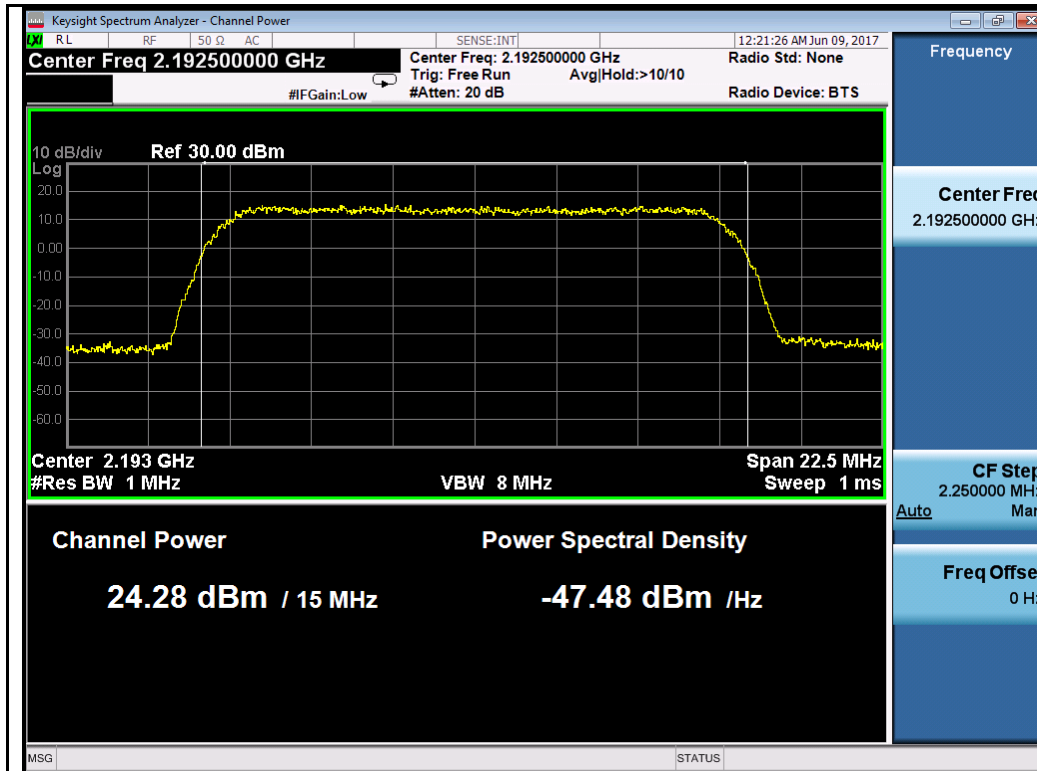

15M QPSK High

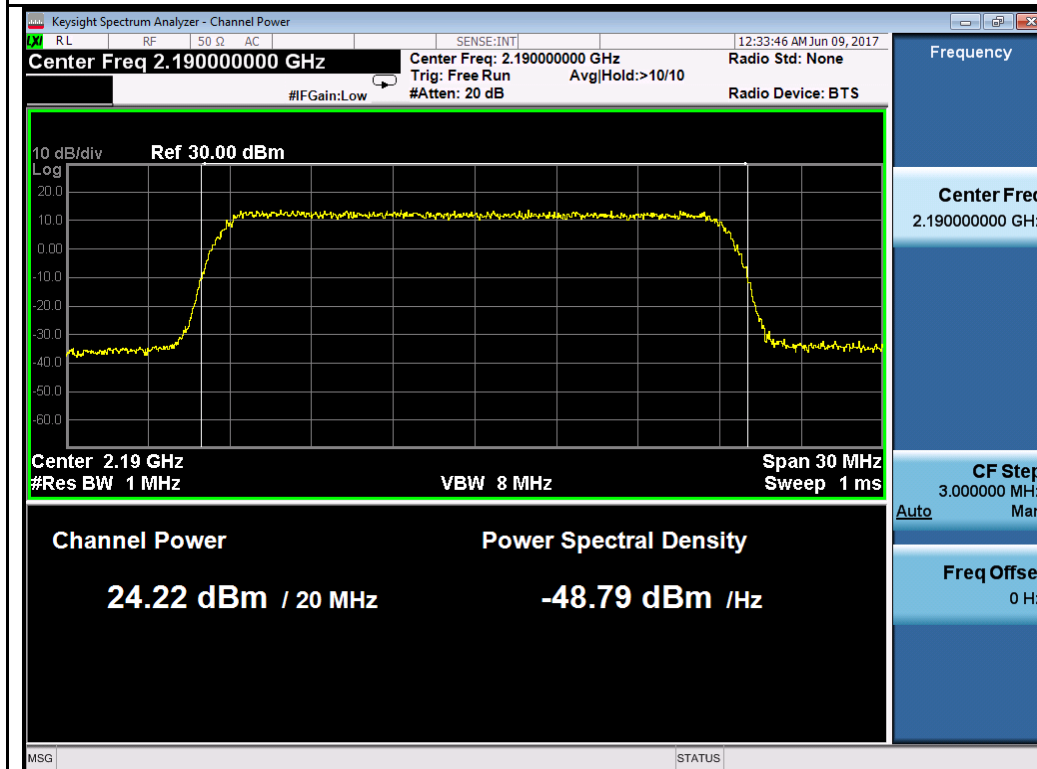

20M QPSK High

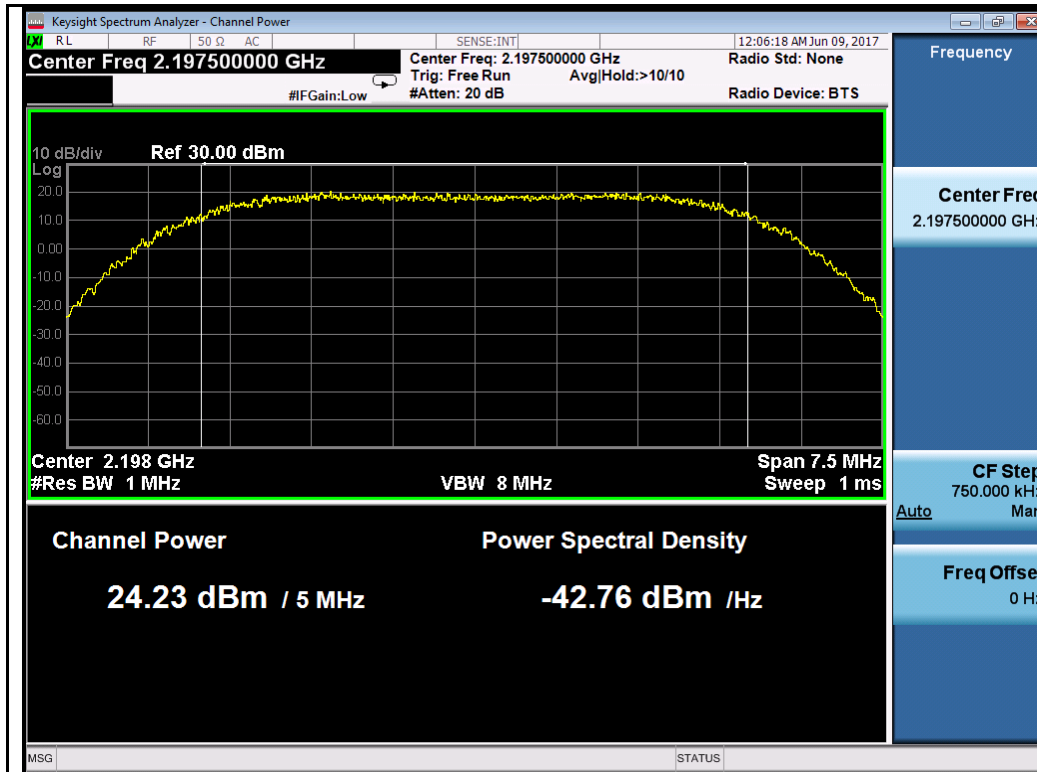

5M 64QAM High

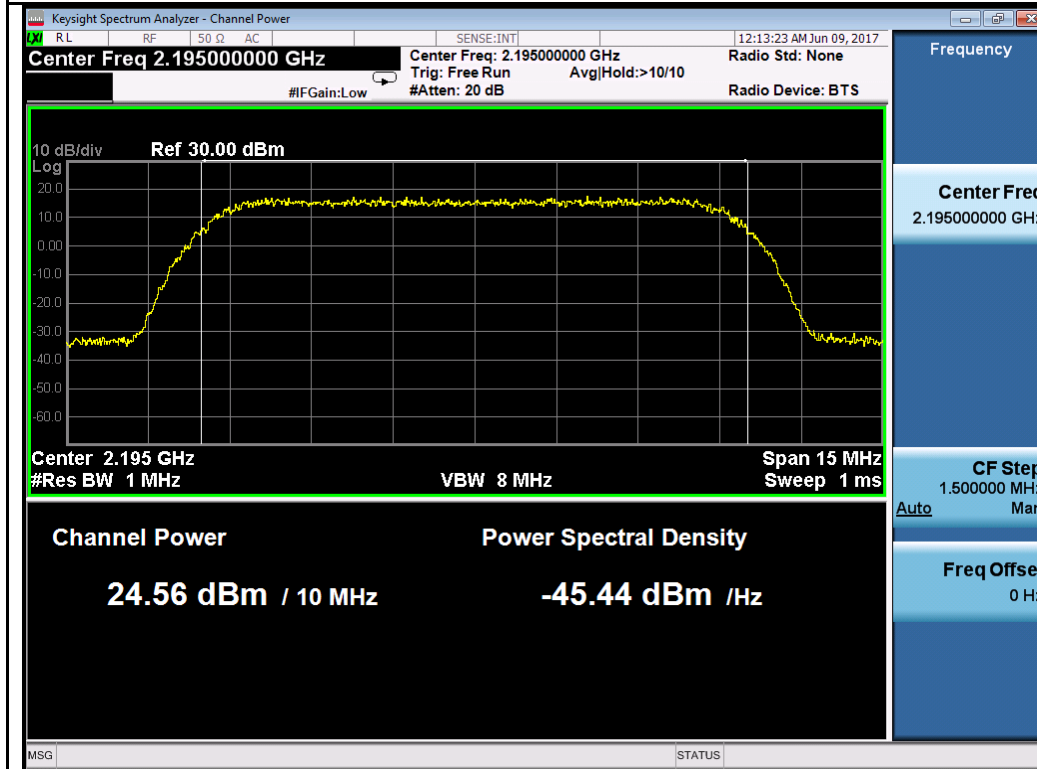

10M 64QAM High

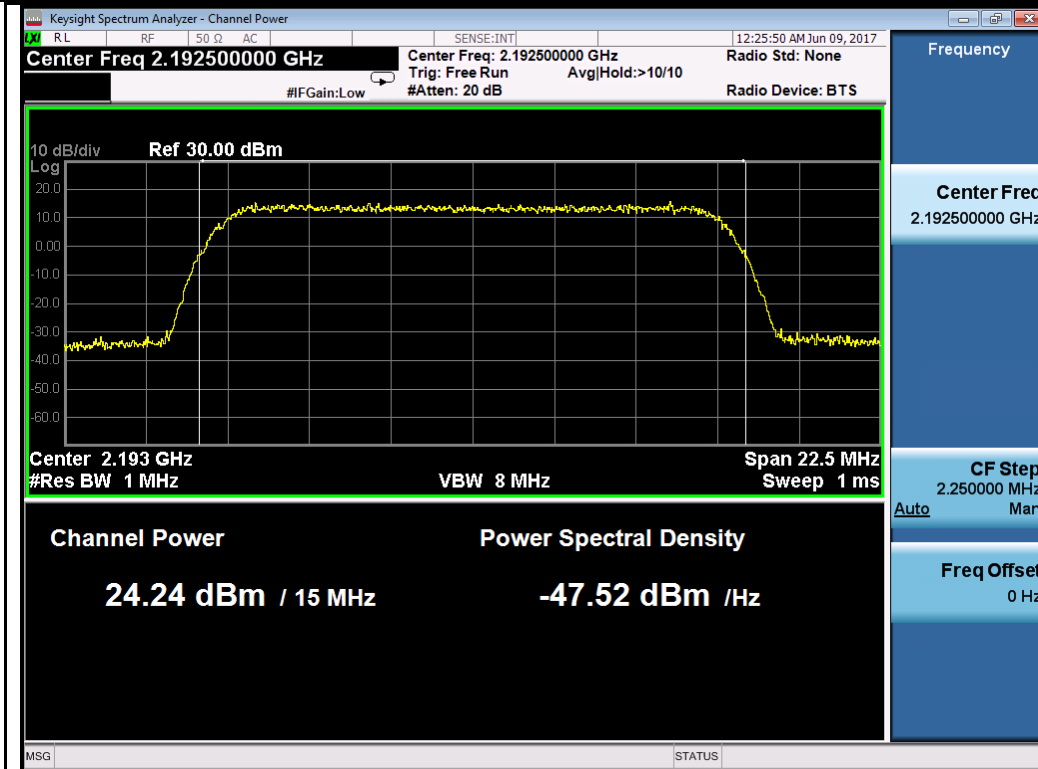

15M 64QAM High

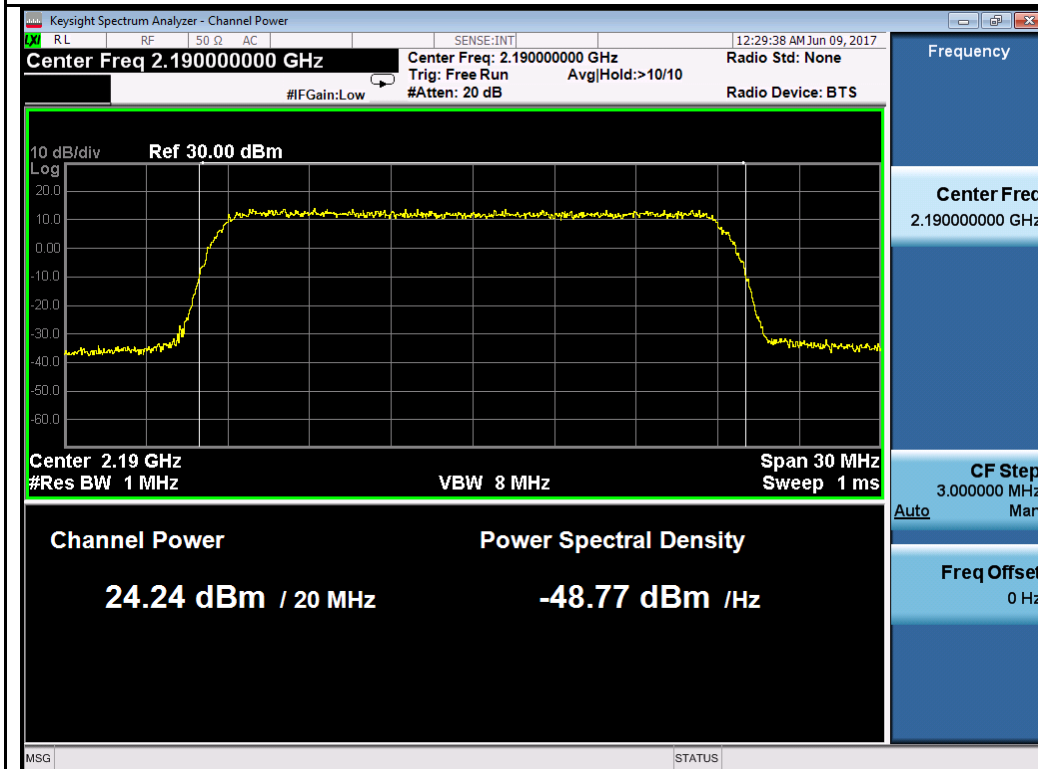

20M 64QAM High

Chain2:

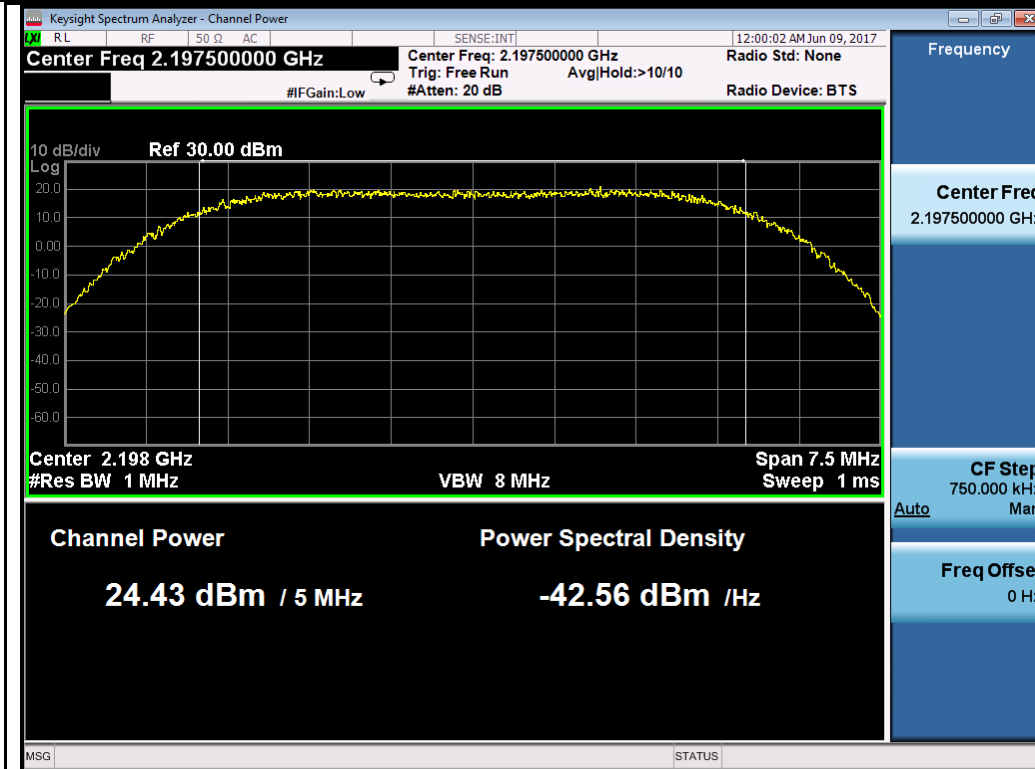

5M QPSK High

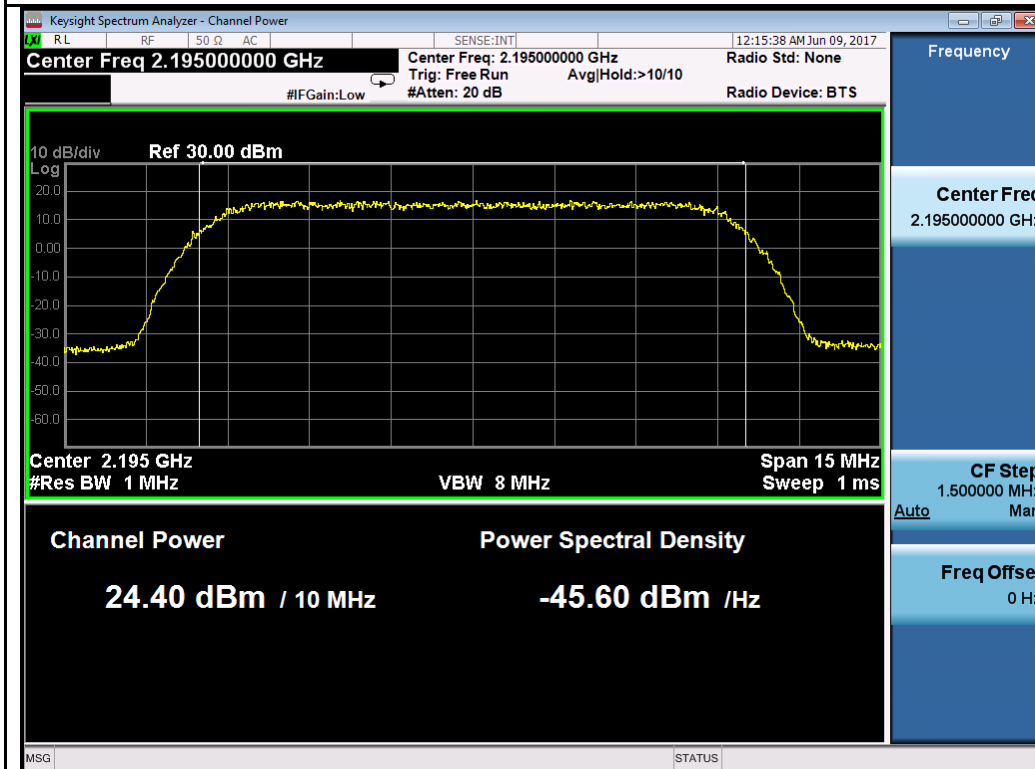

10M QPSK High

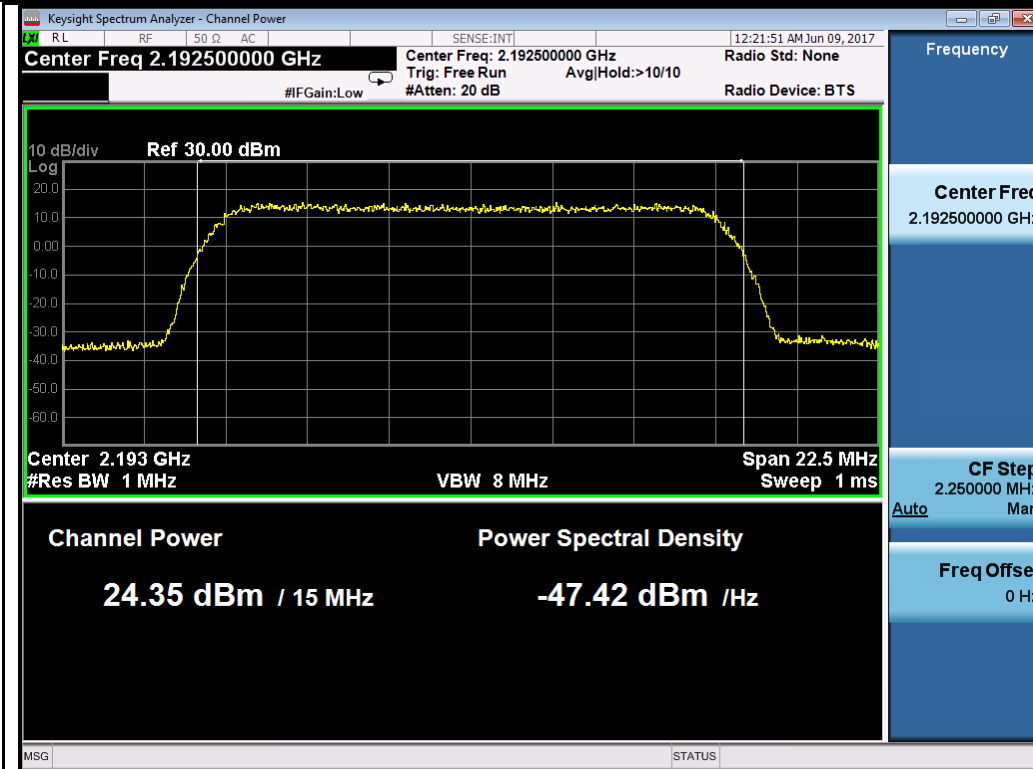

15M QPSK High

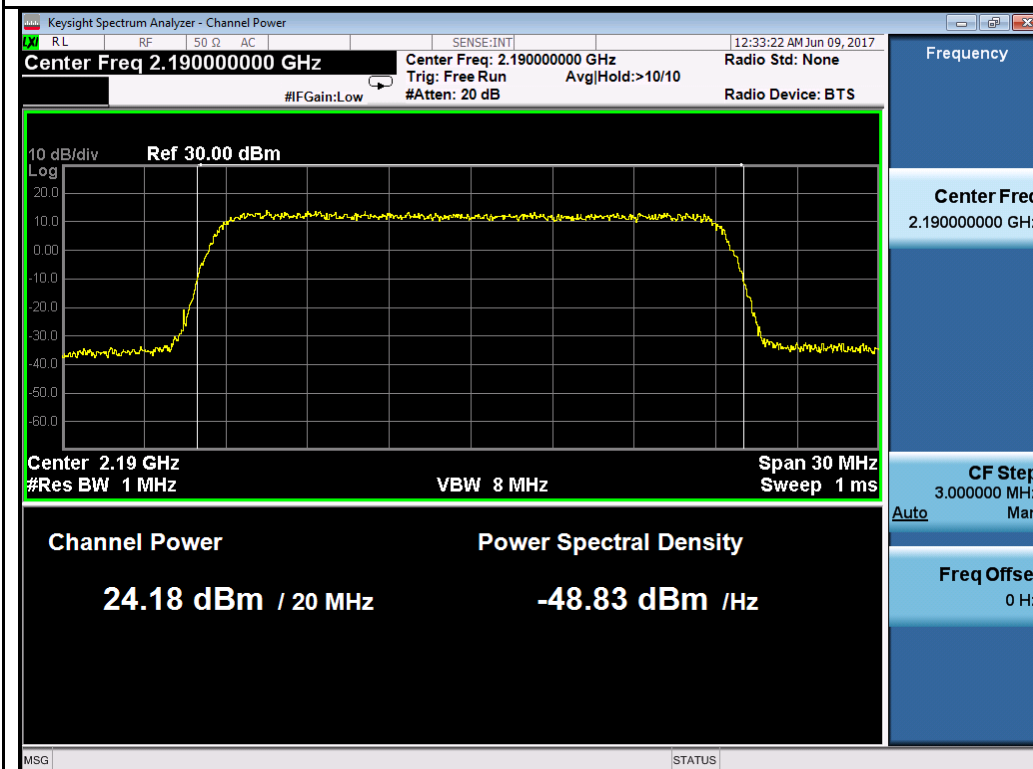

20M QPSK High

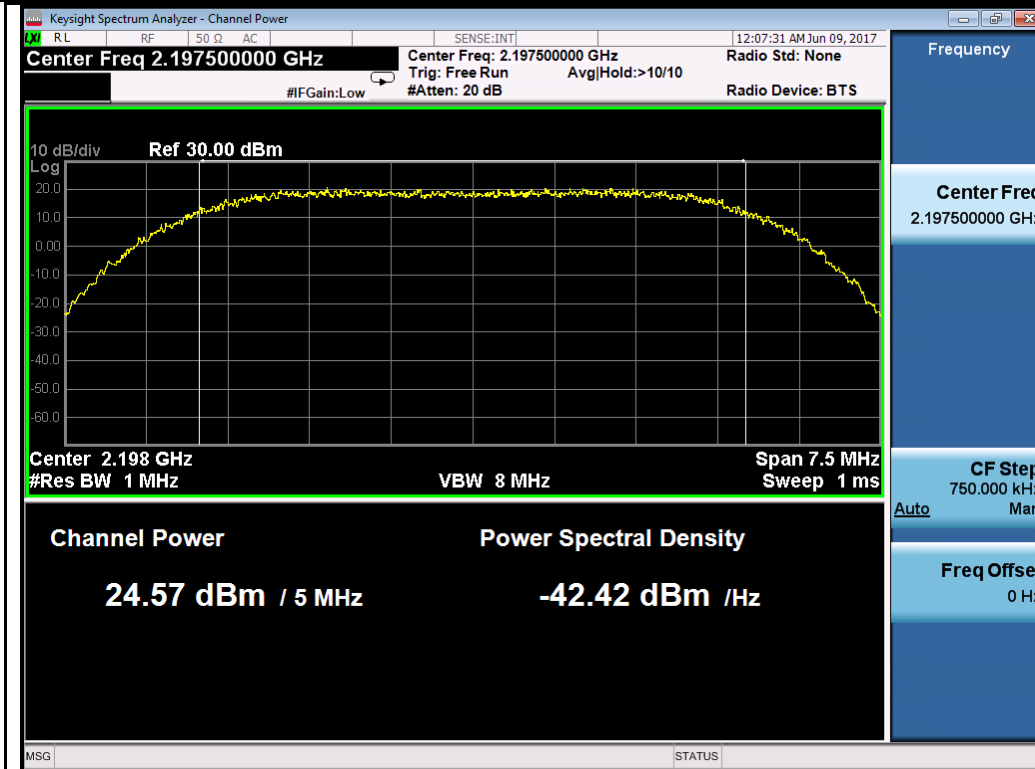

5M 64QAM High

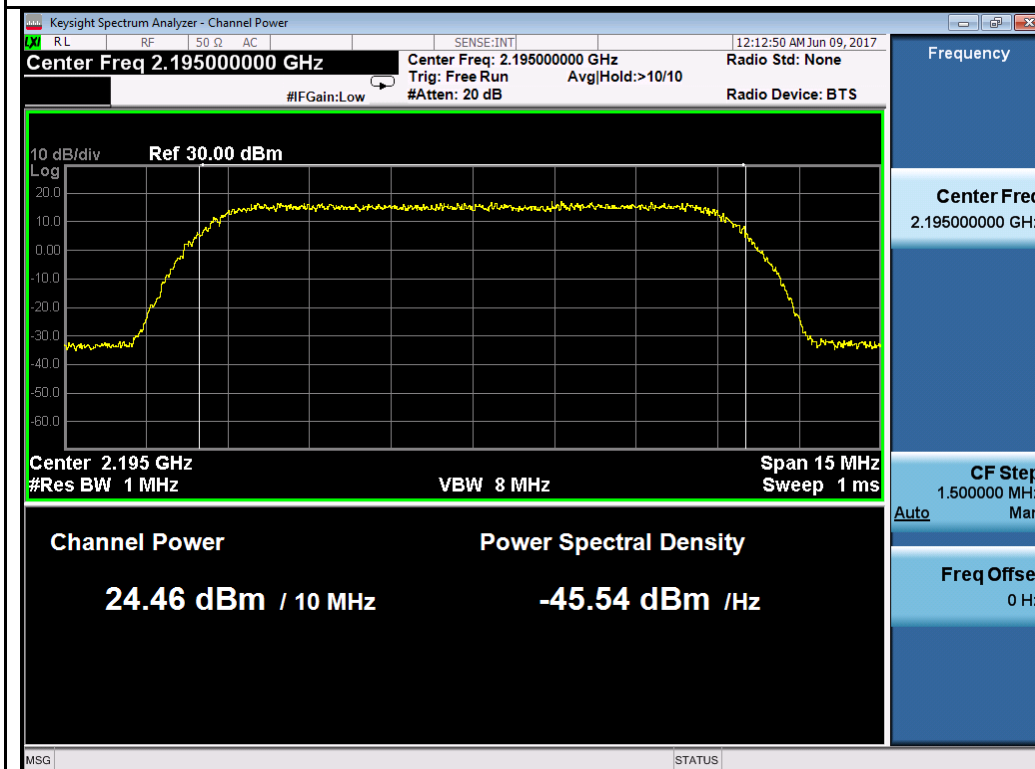

10M 64QAM High



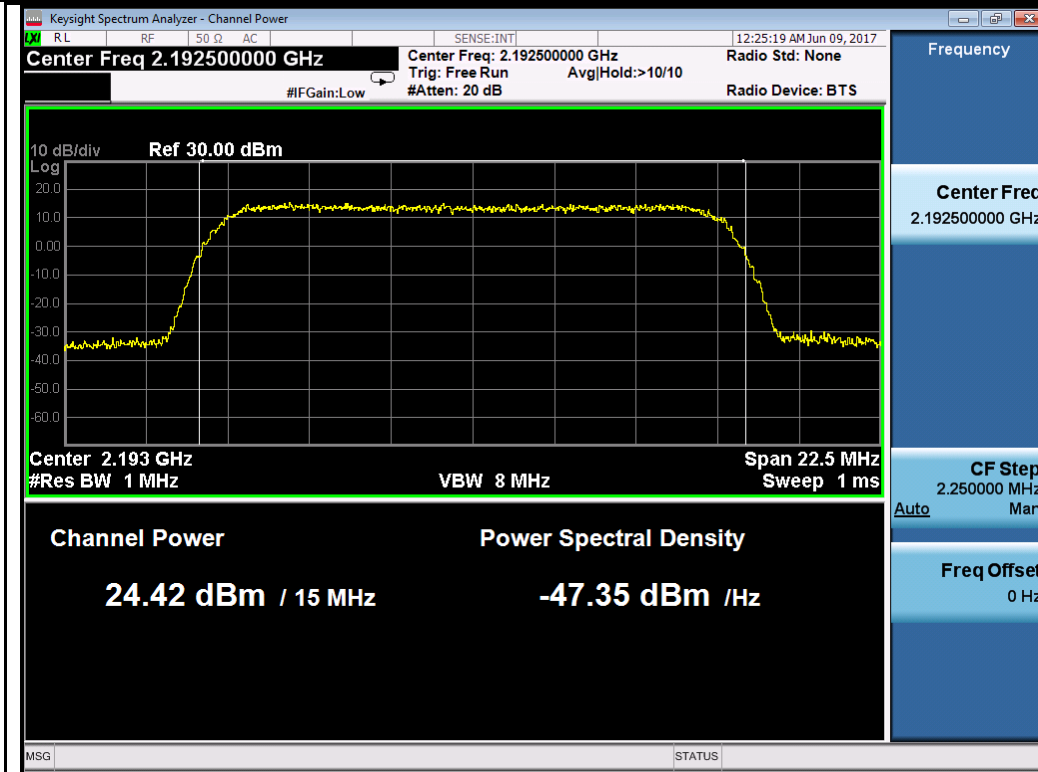

15M 64QAM High

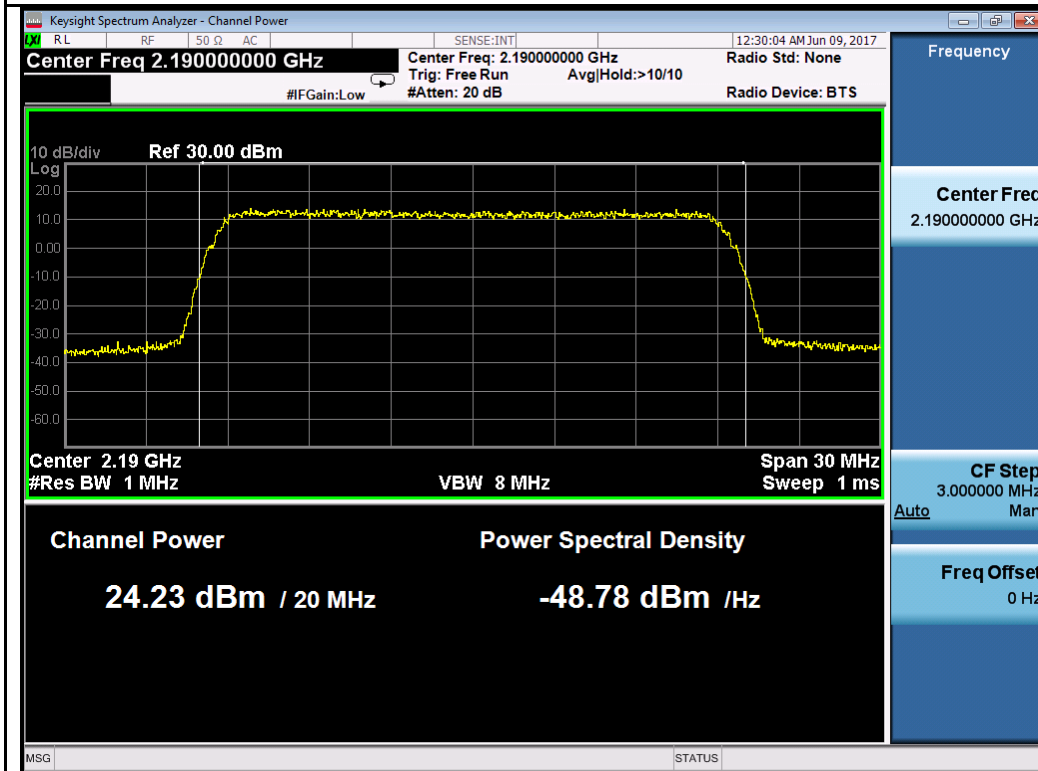

20M 64QAM High

## 10.2 Peak-Average Ratio

### Requirement(s):

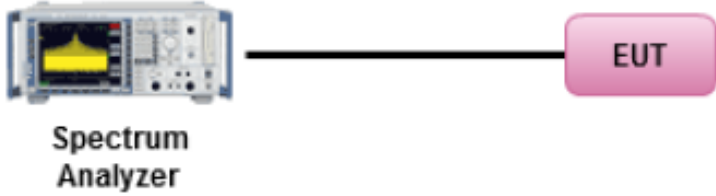
Spec	Item	Requirement	Applicable
47CFR27.50	(b)	The peak-to-average power ratio (PAPR) of the transmitter output power must not exceed 13 dB. The PAPR measurements should be made using either an instrument with complementary cumulative distribution function (CCDF) capabilities to determine that PAPR will not exceed 13 dB for more than 0.1 percent of the time or other Commission approved procedure. The measurement must be performed using a signal corresponding to the highest PAPR expected during periods of continuous transmission.	<input checked="" type="checkbox"/>
Test Setup	 <p style="text-align: center;"><b>Spectrum Analyzer</b> ——— <b>EUT</b></p>		
Test Procedure	<ul style="list-style-type: none"> <li>- EUT was set for low, mid, high channel with modulated mode and highest RF output power.</li> <li>- The spectrum analyzer was connected to the antenna terminal.</li> </ul>		
Test Date	01/13/2017 – 06/09/2017	Environmental condition	Temperature 23°C Relative Humidity 48% Atmospheric Pressure 1008mbar
Remark	NONE		
Result	<input checked="" type="checkbox"/> Pass <input type="checkbox"/> Fail		

Test Data     Yes                       N/A

Test Plot     Yes (See below)             N/A

Test was done by Chen Ge at RF Test Site.

Test Data for LTE band 4:

Type	Channel	Frequency (MHz)	Peak-Average Ratio (dB)	Peak-Average Ratio (dB)
5MHz BW, QPSK	Low	2112.5	8.35	13
	Mid	2132.5	8.15	13
	High	2152.5	7.98	13
5MHz BW, 64QAM	Low	2112.5	8.04	13
	Mid	2132.5	8.05	13
	High	2152.5	7.95	13
10MHz BW, QPSK	Low	2115.0	7.83	13
	Mid	2132.5	7.79	13
	High	2150.0	7.79	13
10MHz BW, 64QAM	Low	2115.0	7.72	13
	Mid	2132.5	7.64	13
	High	2150.0	7.67	13
15MHz BW, QPSK	Low	2117.5	9.24	13
	Mid	2132.5	9.18	13
	High	2147.5	9.27	13
15MHz BW, 64QAM	Low	2117.5	8.84	13
	Mid	2132.5	8.43	13
	High	2147.5	8.71	13
20MHz BW, QPSK	Low	2120.0	9.78	13
	Mid	2132.5	9.74	13
	High	2145.0	9.74	13
20MHz BW, 64QAM	Low	2120.0	9.61	13
	Mid	2132.5	9.79	13
	High	2145.0	9.74	13

Test Data for LTE band 66:

Type	Channel	Frequency (MHz)	Peak-Average Ratio (dB)	Peak-Average Ratio (dB)
5MHz BW, QPSK	High	2197.5	8.08	13
5MHz BW, 64QAM	High	2197.5	8.16	13
10MHz BW, QPSK	High	2195	7.87	13
10MHz BW, 64QAM	High	2195	7.75	13
15MHz BW, QPSK	High	2192.5	9.00	13
15MHz BW, 64QAM	High	2192.5	9.53	13
20MHz BW, QPSK	High	2190	9.68	13
20MHz BW, 64QAM	High	2190	9.66	13

Test Plots for LTE band 4:

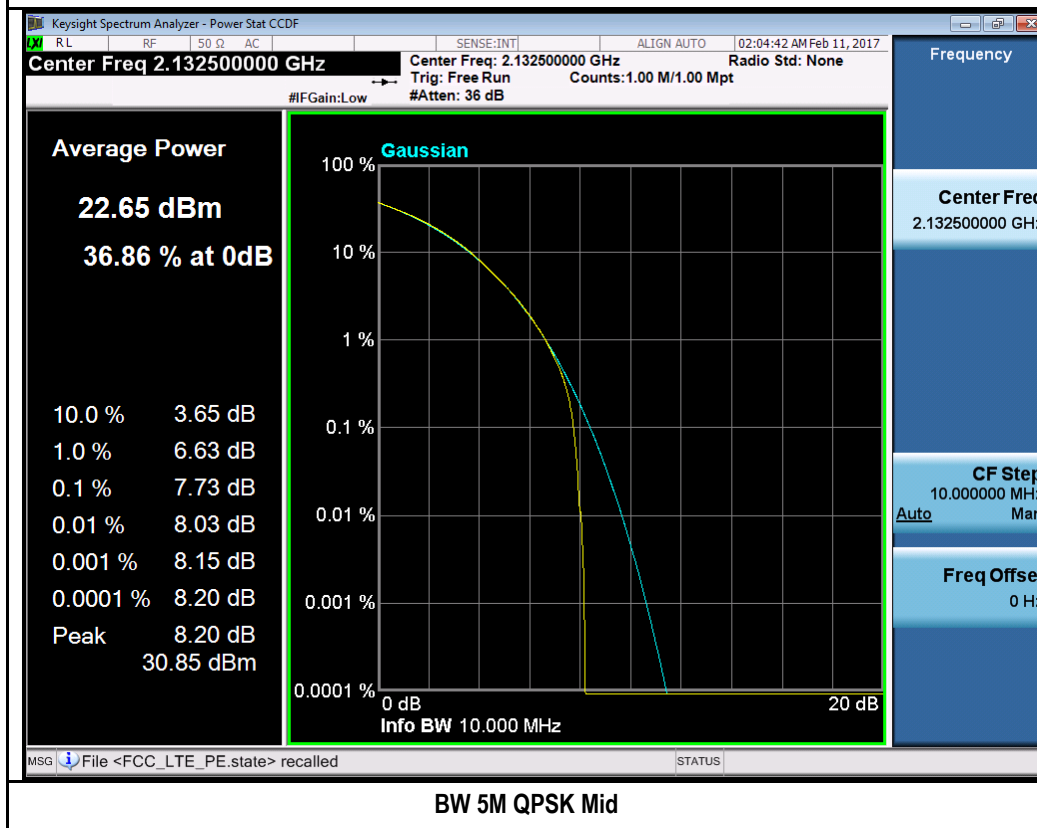
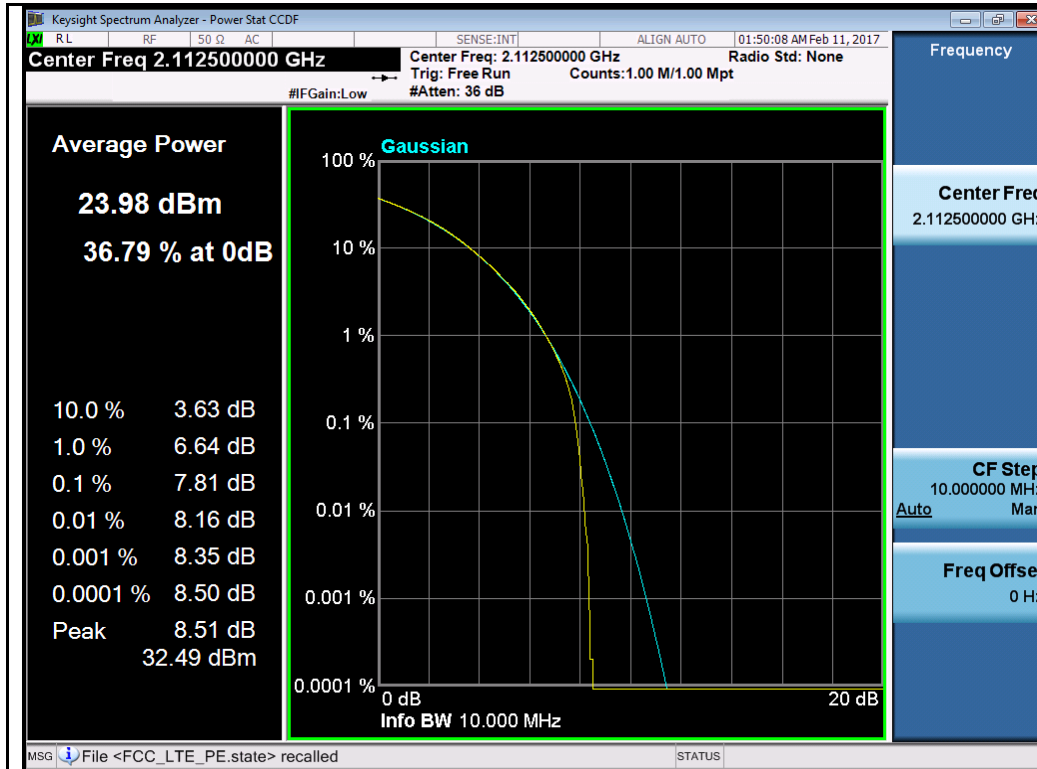

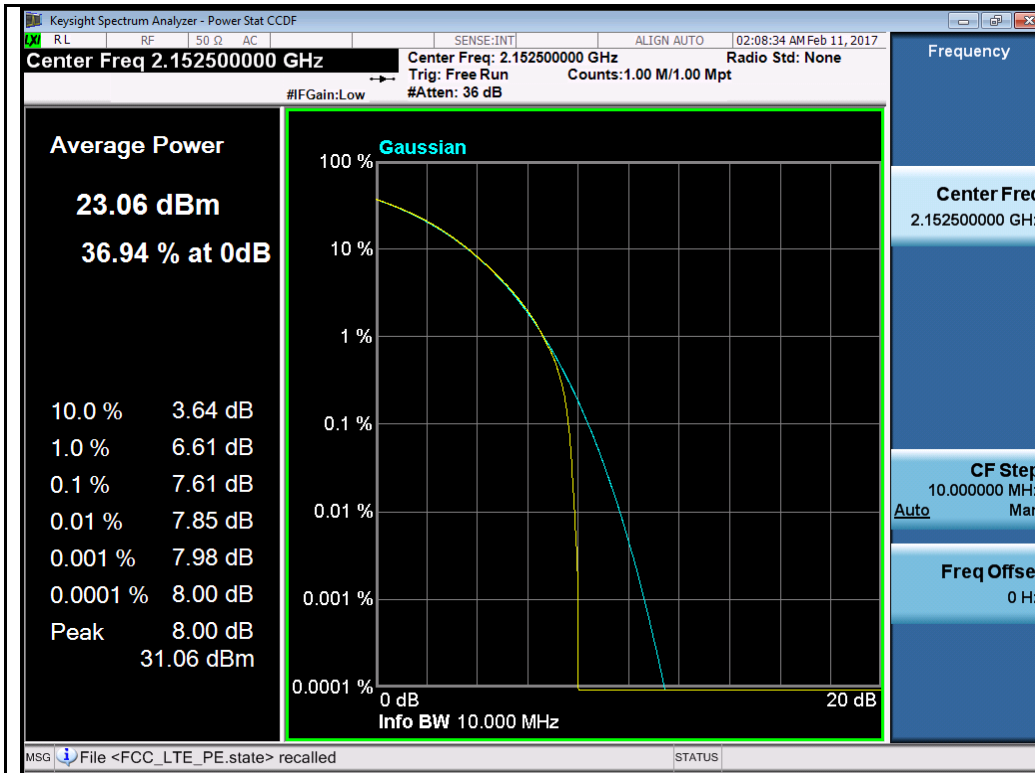

**BW 5M QPSK High**

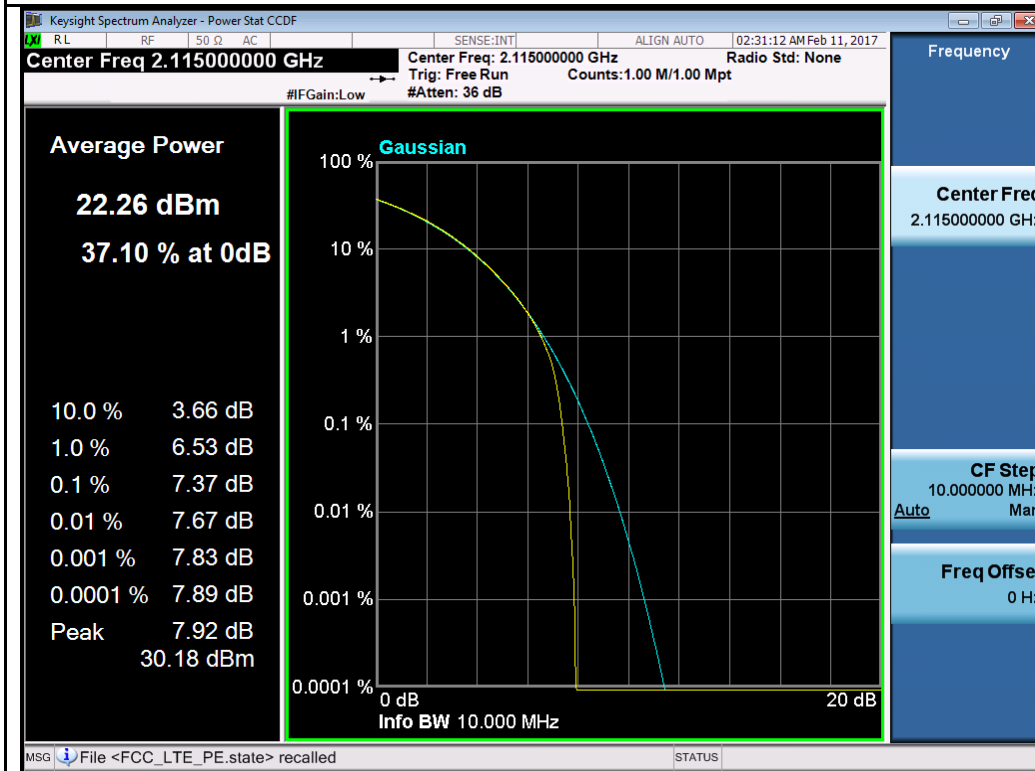

**BW 10M QPSK Low**

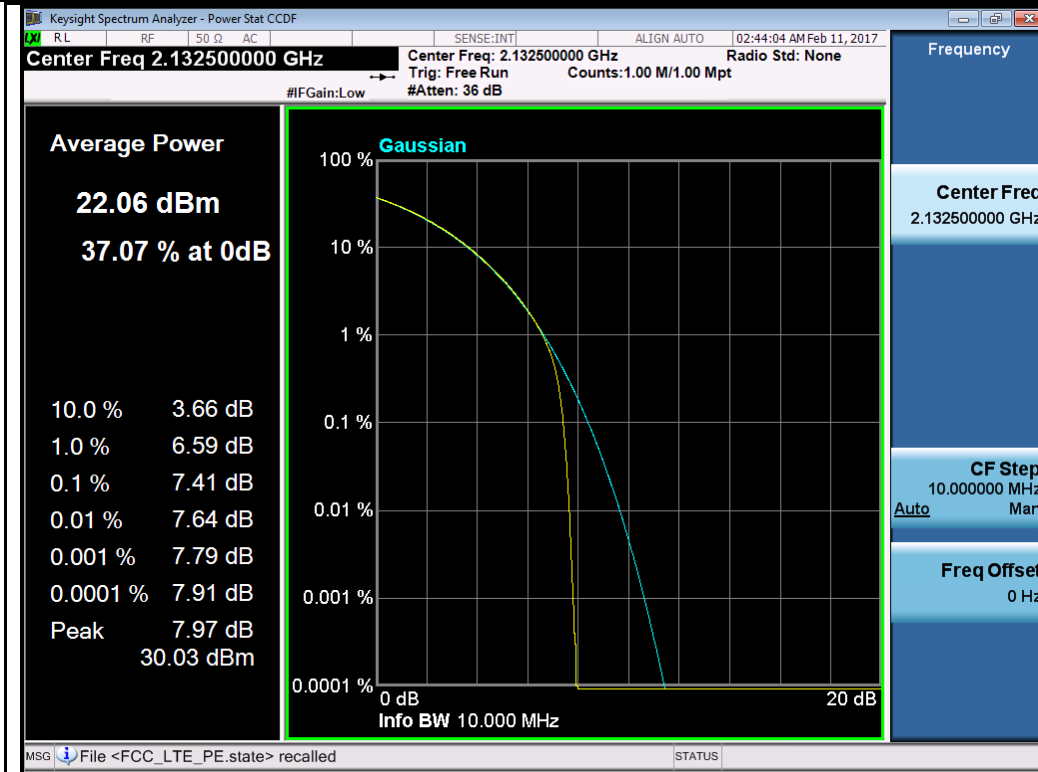

**BW 10M QPSK Mid**

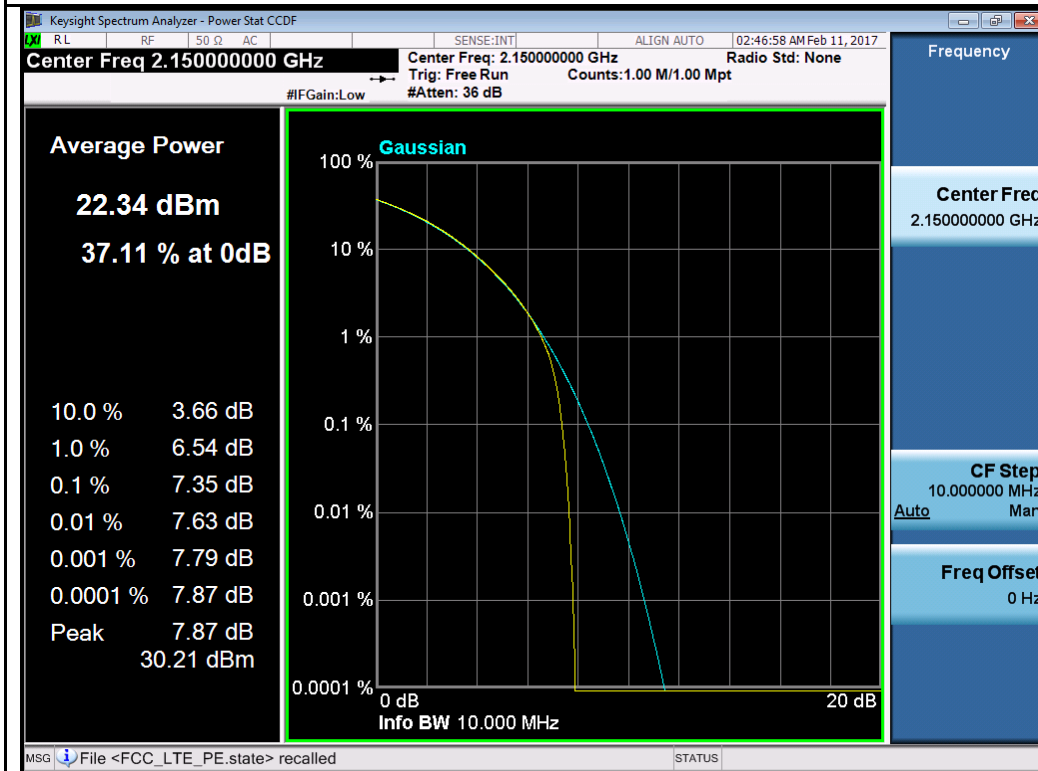

**BW 10M QPSK High**

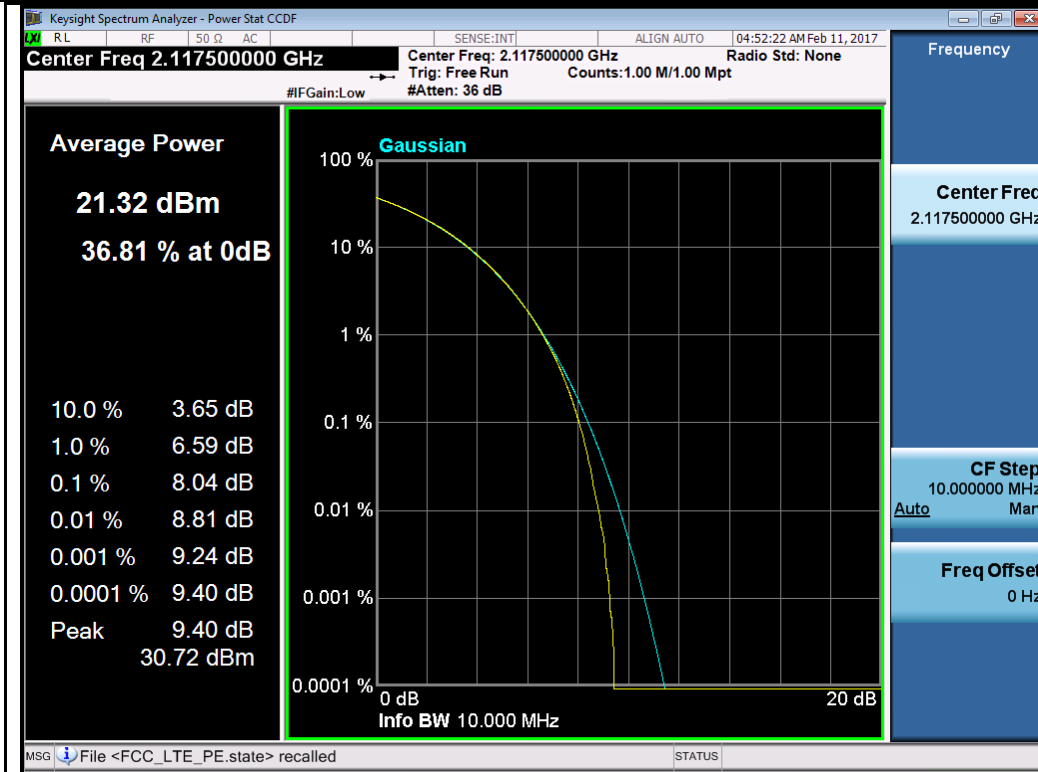

BW 15M QPSK Low

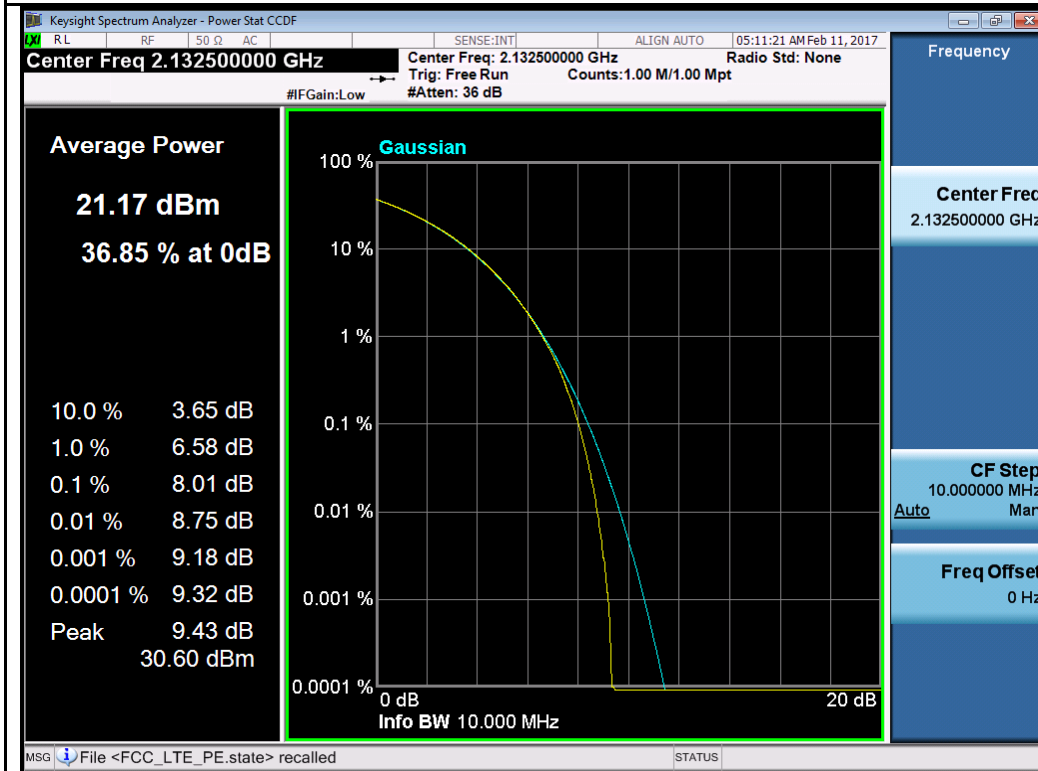

BW 15M QPSK Mid

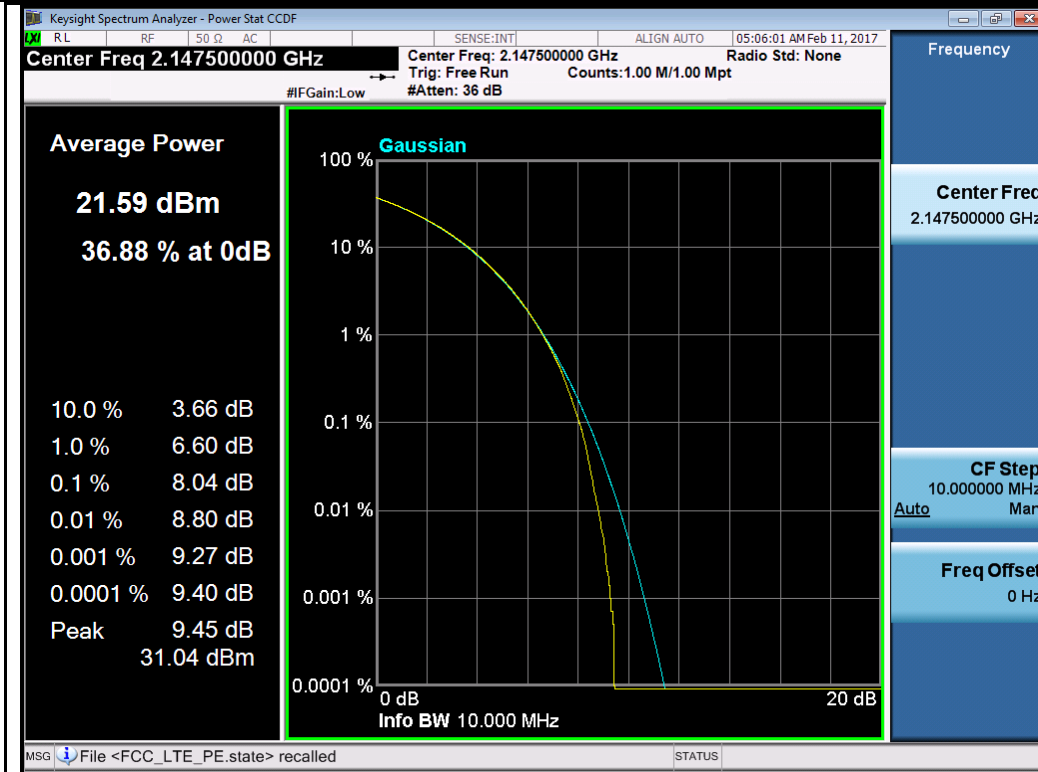

**BW 15M QPSK High**

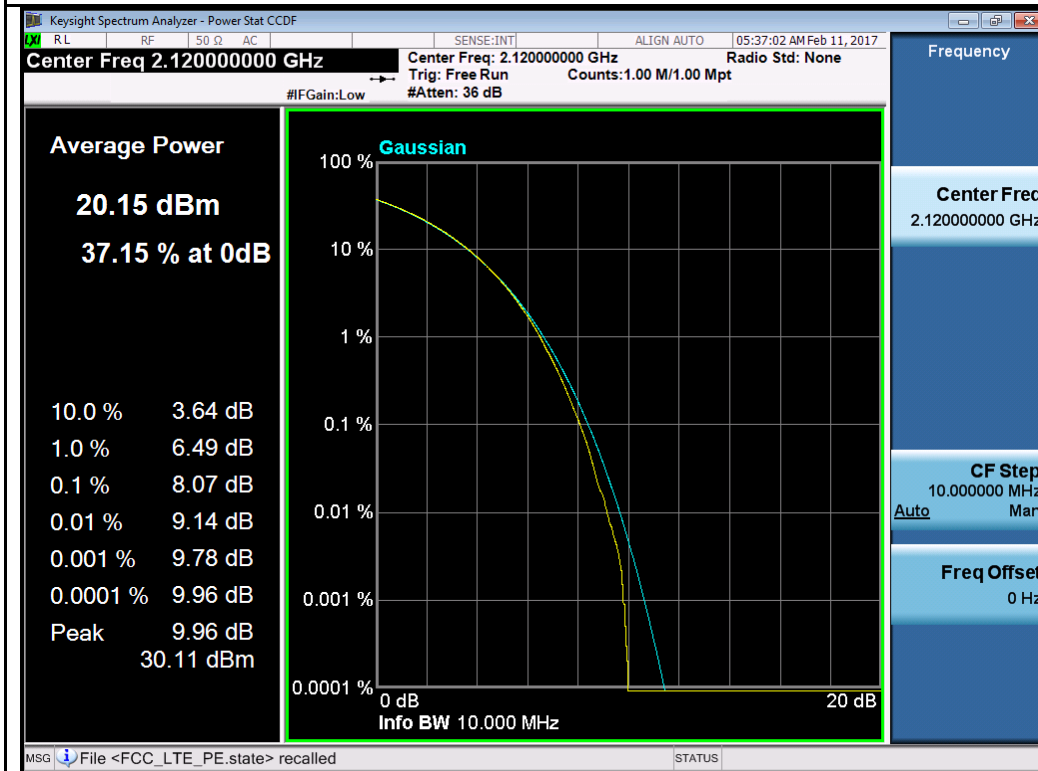

**BW 20M QPSK Low**