

RF TEST REPORT



Report No.: FCC_RF_SL16031001-SPC-003_0412
Supersede Report No.:

Applicant	SpiderCloud Wireless, Inc.		
Product Name	Universal Small Cell 8818 LTE/LTE Module		
Model No.	USC8818-C412-K9		
Test Standard	47CFR Part27		
Test Method	TIA-603-D: 2010		
FCC ID	Y478818C412		
Date of test	10/26/2015 - 11/02/2015 04/12/2016 - 04/15/2016		
Issue Date	04/18/2016		
Test Result	Pass	Fail	
Equipment complied with the specification			[x]
Equipment did not comply with the specification			[]
Gary Chou		Chen Ge	
Test Engineer		Engineer Reviewer	
This test report may be reproduced in full only Test result presented in this test report is applicable to the tested sample only			

Issued By:
SIEMIC Laboratories
775 Montague Expressway, Milpitas, 95035 CA



775 Montague Expressway, Milpitas, CA 95035, USA • Phone: (+1) 408 526 1188 • Facsimile (+1) 408 526 1088

Visit us at: www.siemic.com; Follow us at:

Laboratory Introduction

SIEMIC, headquartered in the heart of Silicon Valley, with superior facilities in US and Asia, is one of the leading independent testing and certification facilities providing customers with one-stop shop services for Compliance Testing and Global Certifications.



In addition to testing and certification, SIEMIC provides initial design reviews and compliance management throughout a project. Our extensive experience with China, Asia Pacific, North America, European, and International compliance requirements, assures the fastest, most cost effective way to attain regulatory compliance for the global markets.

Accreditations for Conformity Assessment

Country/Region	Accreditation Body	Scope
USA	FCC, A2LA	EMC , RF/Wireless , Telecom
Canada	IC, A2LA, NIST	EMC, RF/Wireless , Telecom
Taiwan	BSMI , NCC , NIST	EMC, RF, Telecom , Safety
Hong Kong	OFTA , NIST	RF/Wireless ,Telecom
Australia	NATA, NIST	EMC, RF, Telecom , Safety
Korea	KCC/RRA, NIST	EMI, EMS, RF , Telecom, Safety
Japan	VCCI, JATE, TELEC, RFT	EMI, RF/Wireless, Telecom
Mexico	NOM, COFETEL, Caniety	Safety, EMC , RF/Wireless, Telecom
Europe	A2LA, NIST	EMC, RF, Telecom , Safety
Israel	MOC, NIST	EMC, RF, Telecom, Safety

Accreditations for Product Certifications

Country	Accreditation Body	Scope
USA	FCC TCB, NIST	EMC , RF , Telecom
Canada	IC FCB , NIST	EMC , RF , Telecom
Singapore	iDA, NIST	EMC , RF , Telecom
EU	NB	EMC & R&TTE Directive
Japan	MIC (RCB 208)	RF , Telecom
HongKong	OFTA (US002)	RF , Telecom

CONTENTS

1 REPORT REVISION HISTORY4

2 EXECUTIVE SUMMARY5

3 CUSTOMER INFORMATION5

4 TEST SITE INFORMATION5

5 MODIFICATION5

6 EUT INFORMATION6

6.1 EUT Description6

6.2 Radio Description7

6.3 EUT test modes/configuration Description.....8

6.4 EUT Photos - External9

6.5 EUT Photos - Internal10

6.6 EUT Test Setup Photos12

7 SUPPORTING EQUIPMENT/SOFTWARE AND CABLING DESCRIPTION.....13

7.1 Supporting Equipment13

7.2 Test Software Description13

8 TEST SUMMARY14

9 MEASUREMENT UNCERTAINTY15

10 MEASUREMENTS, EXAMINATION AND DERIVED RESULTS16

10.1 RF Output Power16

10.2 Peak-Average Ratio31

10.3 Occupied Bandwidth42

10.4 Band Edge51

10.5 Radiated Spurious Emission below 1GHz.....59

10.6 Radiated Spurious Emissions above 1GHz.....62

10.7 Frequency Stability.....65

ANNEX A. TEST INSTRUMENT67

ANNEX B. SIEMIC ACCREDITATION68

1 Report Revision History

Report No.	Report Version	Description	Issue Date
FCC_RF_SL16031001-SPC-003_0412	None	Original	04/18/2016

2 Executive Summary

The purpose of this test program was to demonstrate compliance of following product

Company: SpiderCloud Wireless, Inc.
Product: Universal Small Cell 8818 LTE/LTE Module
Model: USC8818-C412-K9

against the current Stipulated Standards. The specified model product stated above has demonstrated compliance with the Stipulated Standard listed on 1st page.

3 Customer information

Applicant Name	SpiderCloud Wireless, Inc.
Applicant Address	475 Sycamore Dr, Milpitas, CA 95035
Manufacturer Name	SpiderCloud Wireless, Inc.
Manufacturer Address	475 Sycamore Dr, Milpitas, CA 95035

4 Test site information

Lab performing tests	SIEMIC Laboratories
Lab Address	775 Montague Expressway, Milpitas, CA 95035
FCC Test Site No.	881796
IC Test Site No.	4842D-2
VCCI Test Site No.	A0133

5 Modification

Index	Item	Description	Note
-	-	-	-

6 EUT Information

6.1 EUT Description

Product Name	Universal Small Cell 8818 LTE/LTE Module
Model No.	USC8818-C412-K9
Trade Name	SpiderCloud
Serial No.	FOC1910NMSY
Input Power	48VDC
Power Adapter Manu/Model	N/A
Power Adapter SN	-
Hardware version	-
Software version	-
Date of EUT received	10/20/2015
Equipment Class/ Category	PCB, TNB
Operating Frequencies	LTE: TX (729 MHz to 746 MHz), LTE: RX (699 MHz to 716 MHz) LTE: TX (2110 MHz to 2155 MHz), LTE: RX (1710 MHz to 1755 MHz)
Port/Connectors	N/A
Remark	NONE

6.2 Radio Description

Item	LTE	LTE
Operating Band /Radio Type	LTE Band 4	LTE Band 12
Bandwidth	5MHz, 10MHz, 15MHz, 20MHz	5MHz, 10MHz
Modulation	QPSK/16QAM/64QAM	QPSK/16QAM/64QAM
Antenna Type	Internal Omni-directional antenna	Internal Omni-directional antenna
Antenna Gain	2 dBi	2 dBi
Frequency TX(MHz)	TX: 2110 MHz to 2155 MHz RX: 1710 MHz to 1755 MHz	TX: 729 MHz to 746 MHz RX: 699 MHz to 716 MHz

6.3 EUT test modes/configuration Description

Test mode

Final Test Mode		Note
Final_test_mode_1	Continuous transmission, band 4	LTE
Final_test_mode_2	Continuous transmission, band 12	LTE
Remark: LTE band 12 and LTE band 4 are evaluated.		

6.4 EUT Photos - External

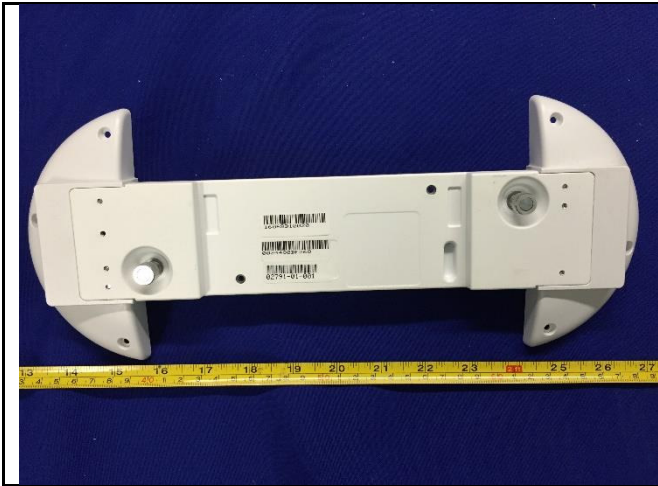

Top View



Bottom View

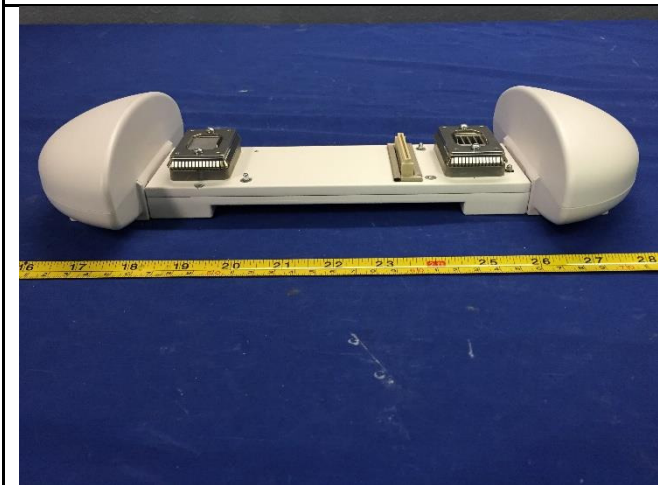

Front View

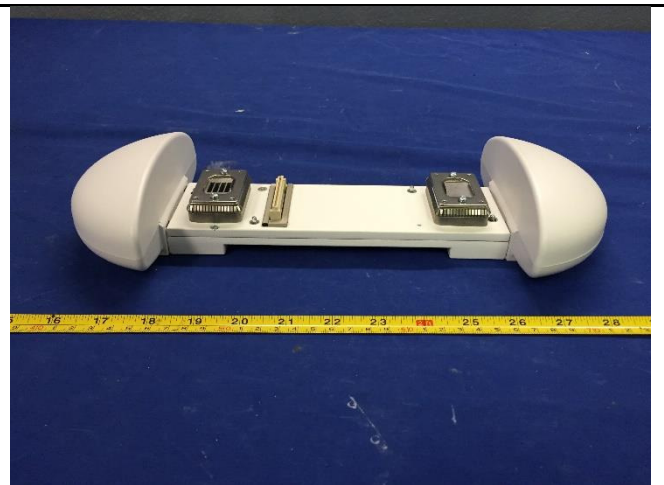

Rear View



Left Side View



Right Side View

6.5 EUT Photos - Internal

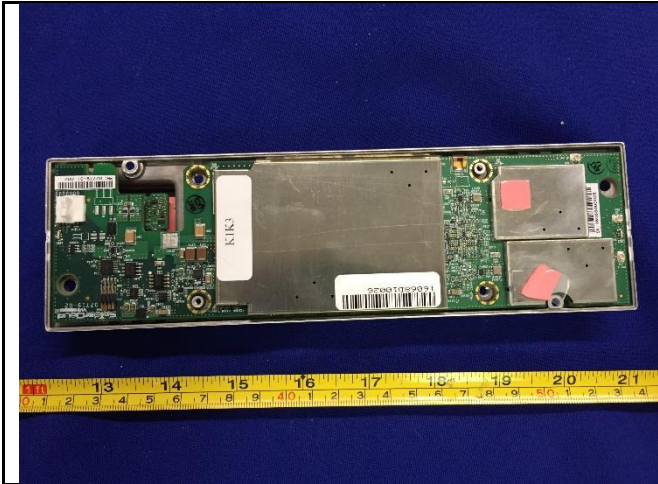

EUT - Open Case View

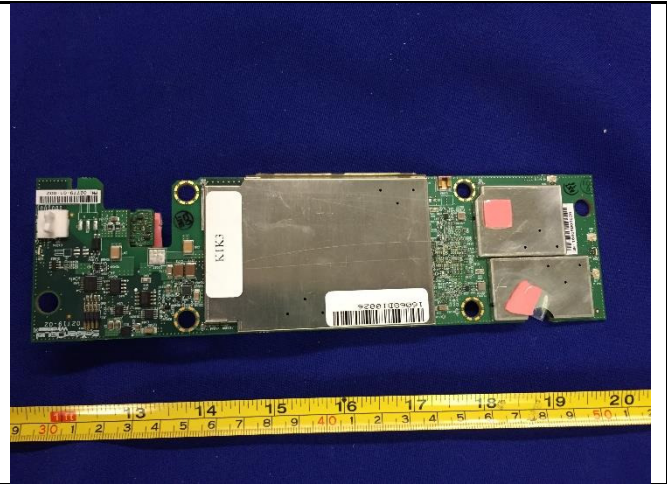

Main PCB - Top View

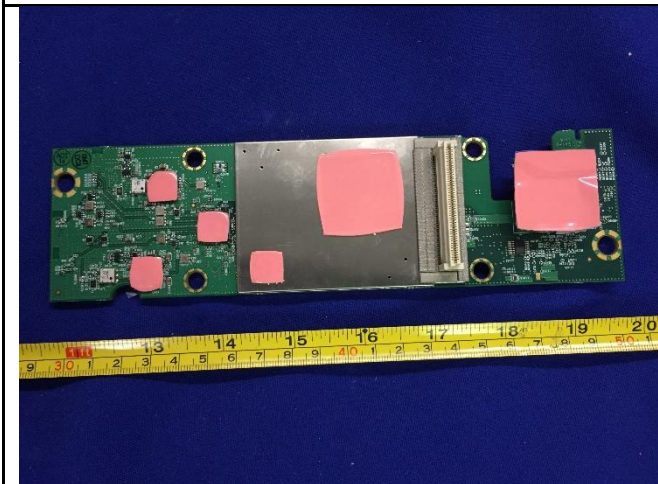

Main PCB - Bottom View

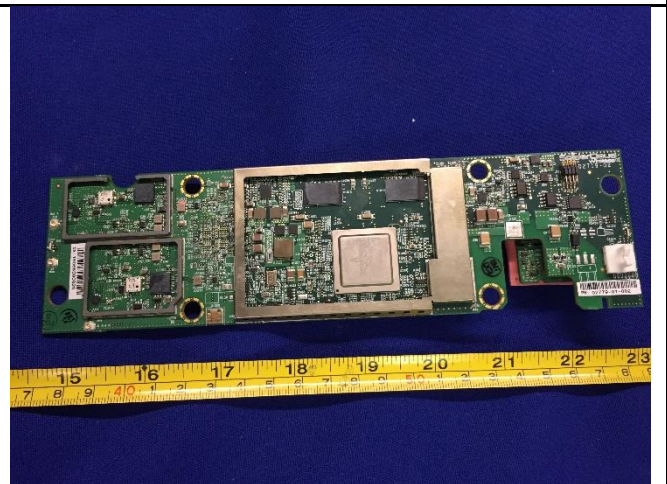

Main PCB - Top View without shielding

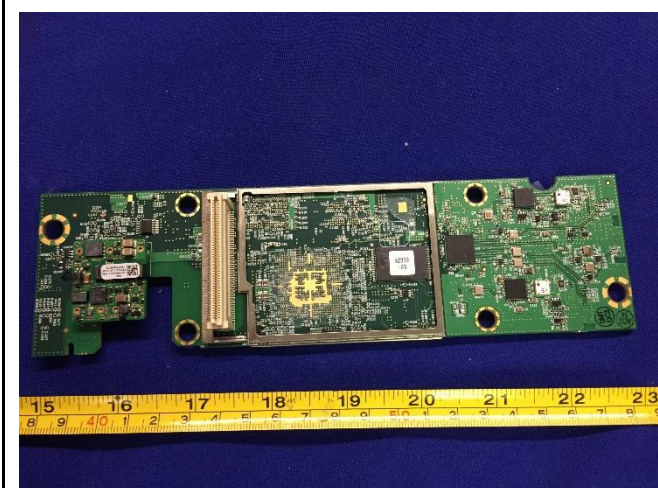

Main PCB - Bottom View without shielding

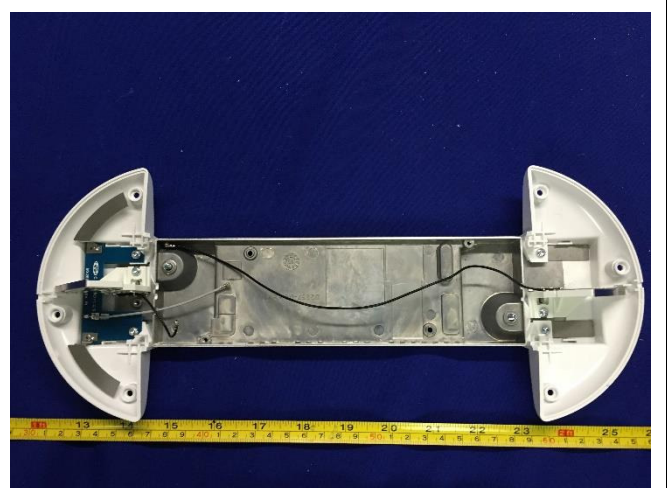

Antenna View

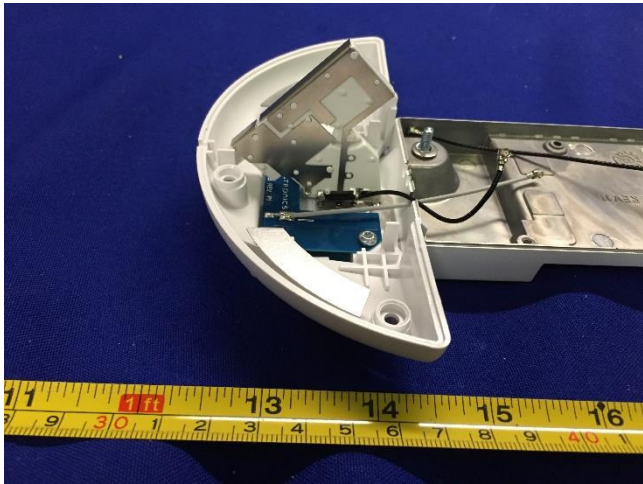

Antenna 1

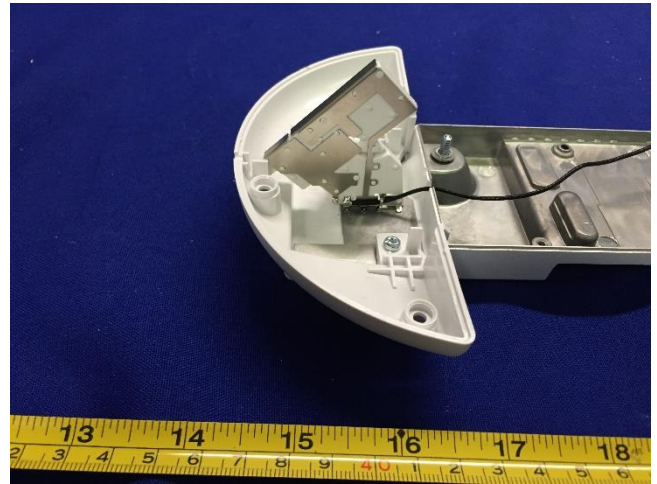

Antenna 2

6.6 EUT Test Setup Photos



Radiated Emissions (<1GHz) – Front View



Radiated Emissions (<1GHz) – Rear View



Radiated Emissions (>1GHz) – Front View



Radiated Emissions (>1GHz) – Rear View

Note: The spurious emission in different EUT orientation was investigated, including the EUT standing up position and the laying down position. The EUT orientation shown in above setup photo is the worst case position.

7 Supporting Equipment/Software and cabling Description

7.1 Supporting Equipment

Item	Supporting Equipment Description	Model	Serial Number	Manufacturer	Note
1	PoE Adatper	POE36U-1AT-R	P90212324A1	Pihong	-
2	Service Node	SCSN-9000	14193C26505	SpiderCloud	-
3	Access Point	AIR-CAP3702I-A-K9	FTX1848RA30	Cisco	-

7.2 Test Software Description

Test Item	Software	Description
RF testing	ePewiew	Enable EUT continuous TX mode and change to different channel

8 Test Summary

Test Item	Test standard		Test Method/Procedure		Pass / Fail
E.R.P/ E.I.R.P	FCC	47CFR27.50	FCC	TIA-603-D: 2010	<input checked="" type="checkbox"/> Pass <input type="checkbox"/> N/A
Occupied Bandwidth	FCC	47CFR27.53	FCC	TIA-603-D: 2010	<input checked="" type="checkbox"/> Pass <input type="checkbox"/> N/A
Peak-Average Ratio	FCC	47CFR27.50	FCC	TIA-603-D: 2010	<input checked="" type="checkbox"/> Pass <input type="checkbox"/> N/A
Spurious and harmonic Emission at antenna port	FCC	47CFR2.1051, 47CFR27.53	FCC	TIA-603-D: 2010	<input checked="" type="checkbox"/> Pass <input type="checkbox"/> N/A
Band Edge	FCC	47CFR2.1053, 47CFR27.53	FCC	TIA-603-D: 2010	<input checked="" type="checkbox"/> Pass <input type="checkbox"/> N/A
Radiated spurious and harmonic emission	FCC	47CFR2.1053, 47CFR27.53	FCC	TIA-603-D: 2010	<input checked="" type="checkbox"/> Pass <input type="checkbox"/> N/A
Frequency stability	FCC	47CFR2.1053, 47CFR27.53	FCC	TIA-603-D: 2010	<input checked="" type="checkbox"/> Pass <input type="checkbox"/> N/A
Remark	<ol style="list-style-type: none"> All measurement uncertainties do not take into consideration for all presented test results. The applicant shall ensure frequency stability by showing that an emission is maintained within the band of operation under all normal operating conditions as specified in the user's manual. 				

9 Measurement Uncertainty

Test Item	Frequency Range	Description	Uncertainty
Band Edge and Radiated Spurious Emissions	30MHz – 1GHz	Confidence level of approximately 95% (in the case where distributions are normal), with a coverage factor of 2 (for EUTs < 0.5m X 0.5m X 0.5m)	+5.6dB/-4.5dB
Band Edge and Radiated Spurious Emissions	1GHz – 40GHz	Confidence level of approximately 95% (in the case where distributions are normal), with a coverage factor of 2 (for EUTs < 0.5m X 0.5m X 0.5m)	+4.3dB/-4.1dB

10 Measurements, Examination and Derived Results

10.1 RF Output Power

Requirement(s):

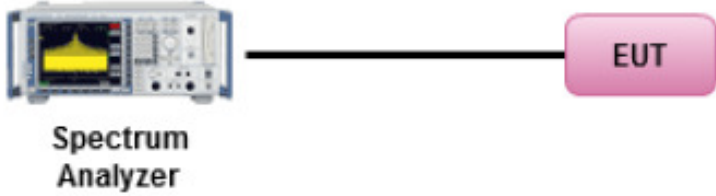
Spec	Item	Requirement	Applicable
47CFR27.50	-	The maximum effective radiated power (ERP) of fixed and base station must not exceed 1000 Watts.	<input checked="" type="checkbox"/>
Test Setup	 <p>The diagram illustrates the test setup. On the left is a Spectrum Analyzer with a yellow signal trace on its screen. A black cable connects the Spectrum Analyzer to a pink rounded rectangle labeled 'EUT' (Equipment Under Test).</p>		
Test Procedure	<ul style="list-style-type: none"> - EUT was set for low, mid, high channel with modulated mode and highest RF output power. - The spectrum analyzer was connected to the antenna terminal. 		
Test Date	10/26/2015 – 11/02/2015 04/12/2016 – 04/15/2016	Environmental condition	Temperature 22°C Relative Humidity 48% Atmospheric Pressure 1008mbar
Remark	<p>For LTE mode, EUT is using 2x2 MIMO, which has 2 transmit antennas. They are correlated to each other. The directional gain is calculated per the formula at below,</p> <p style="text-align: center;">Directional gain dBi = Gmax + 10 Log10 N</p> <p>The max gain of single antenna is 2 dBi. So the directional gain = 5 dBi</p>		
Result	<input checked="" type="checkbox"/> Pass <input type="checkbox"/> Fail		

Test Data Yes N/A

Test Plot Yes (See below) N/A

Test was done by *Chen Ge* at RF test site.

Test Data for LTE band 4:

Type	Channel	Frequency (MHz)	Measured PW -Port 1(dBm)	Measured PW -Port 2(dBm)	Combined Power (dBm)	Antenna Gain (dBi)	E.I.R.P (dBm)
5MHz BW, QPSK	Low	2112.5	16.30	18.15	20.33	5	25.33
	Mid	2132.5	17.04	17.13	20.10	5	25.10
	High	2152.5	17.13	17.67	20.42	5	25.42
5MHz BW, 64QAM	Low	2112.5	16.33	18.13	20.33	5	25.33
	Mid	2132.5	17.16	17.31	20.25	5	25.25
	High	2152.5	16.62	17.01	19.83	5	24.83
10MHz BW, QPSK	Low	2115.0	15.40	16.91	19.23	5	24.23
	Mid	2132.5	16.72	16.73	19.74	5	24.74
	High	2150.0	17.25	17.27	20.27	5	25.27
10MHz BW, 64QAM	Low	2115.0	15.46	17.23	19.44	5	24.44
	Mid	2132.5	17.01	17.36	20.20	5	25.20
	High	2150.0	17.37	17.62	20.51	5	25.51
15MHz BW, QPSK	Low	2117.5	15.24	16.95	19.19	5	24.19
	Mid	2132.5	17.02	17.09	20.07	5	25.07
	High	2147.5	16.78	17.44	20.13	5	25.13
15MHz BW, 64QAM	Low	2117.5	15.53	16.75	19.19	5	24.19
	Mid	2132.5	16.95	17.26	20.12	5	25.12
	High	2147.5	17.52	17.86	20.70	5	25.70
20MHz BW, QPSK	Low	2120.0	16.57	17.58	20.11	5	25.11
	Mid	2132.5	17.74	17.78	20.77	5	25.77
	High	2145.0	17.67	17.70	20.70	5	25.70
20MHz BW, 64QAM	Low	2120.0	16.72	17.90	20.36	5	25.36
	Mid	2132.5	17.09	17.40	20.26	5	25.26
	High	2145.0	17.78	17.77	20.79	5	25.79

Test Data for LTE band 12:

Type	Channel	Frequency (MHz)	Measured PW -Port 1(dBm)	Measured PW -Port 2(dBm)	Combined Power (dBm)	Antenna Gain (dBi)	E.I.R.P (dBm)
5MHz BW, QPSK	Low	731.5	17.21	17.28	20.26	5	25.26
	Mid	737.5	17.16	17.18	20.18	5	25.18
	High	743.5	17.26	17.29	20.29	5	25.29
5MHz BW, 64QAM	Low	731.5	17.12	17.10	20.12	5	25.12
	Mid	737.5	17.11	17.26	20.20	5	25.20
	High	743.5	17.30	17.36	20.34	5	25.34
10MHz BW, QPSK	Low	734.0	17.41	17.40	20.42	5	25.42
	Mid	737.5	17.54	17.42	20.49	5	25.49
	High	741.0	17.58	17.53	20.57	5	25.57
10MHz BW, 64QAM	Low	734.0	17.19	17.23	20.22	5	25.22
	Mid	737.5	17.53	17.45	20.50	5	25.05
	High	741.0	17.52	17.52	20.53	5	25.53

Test Plots for Band 4-QPSK-5MHz

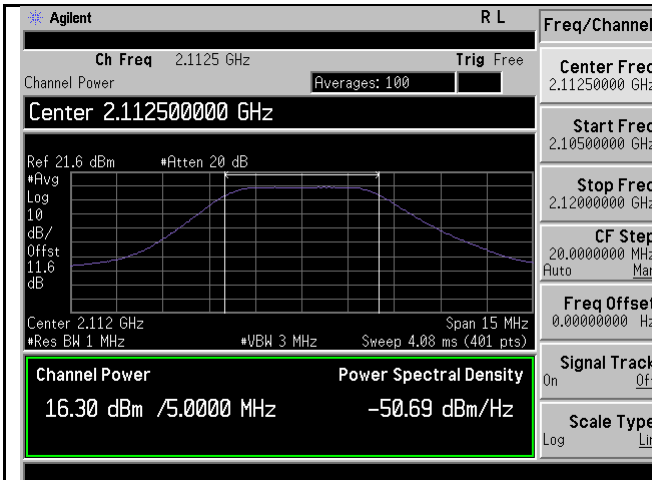

PWR-Band4-QPSK-5M BW-Low CH-Port1

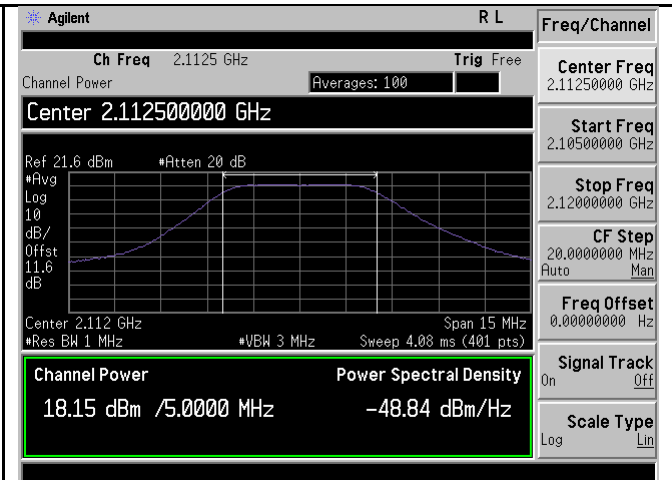

PWR-Band4-QPSK-5M BW-Low CH-Port2

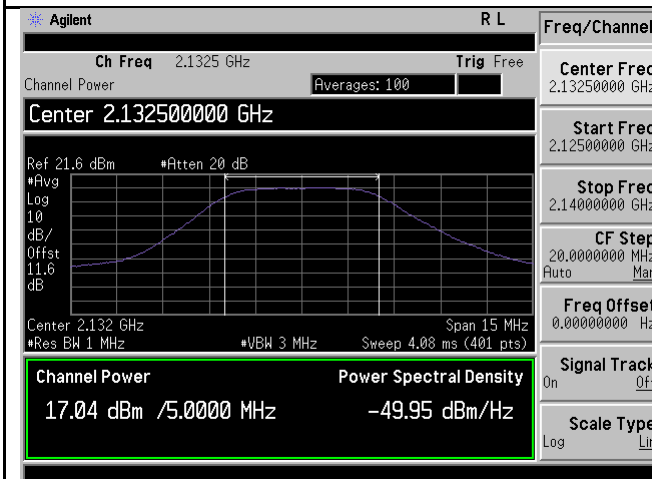

PWR-Band4-QPSK-5M BW-Mid CH-Port1

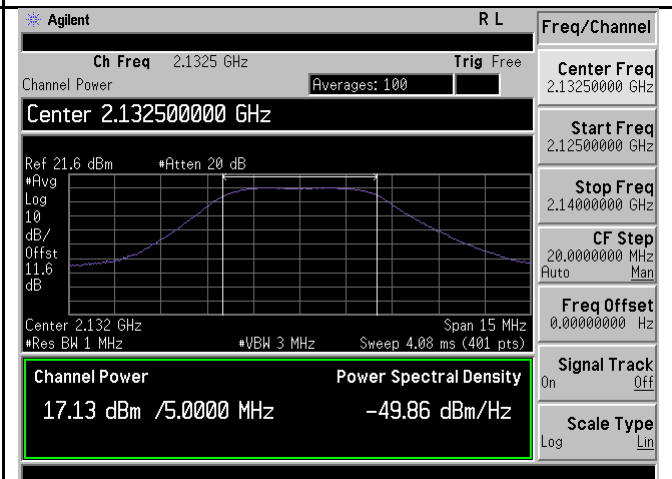

PWR-Band4-QPSK-5M BW-Mid CH-Port2

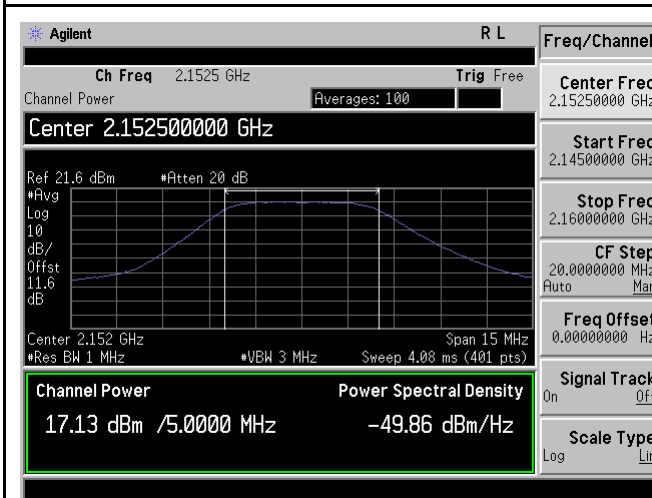

PWR-Band4-QPSK-5M BW-High CH-Port1

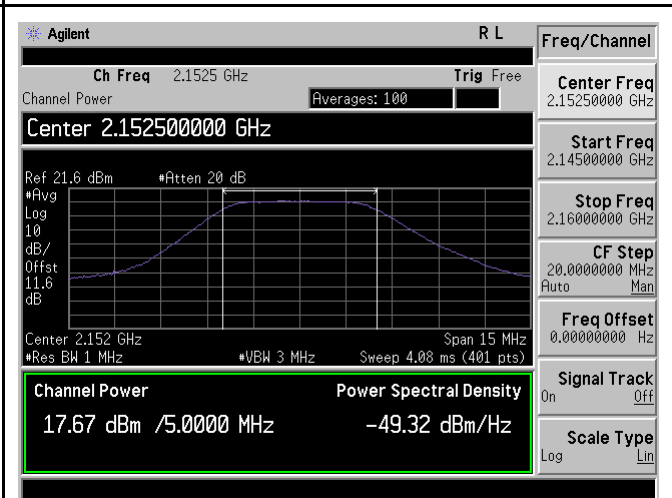

PWR-Band4-QPSK-5M BW-High CH-Port2

Test Plots for Band 4-64QAM-5MHz

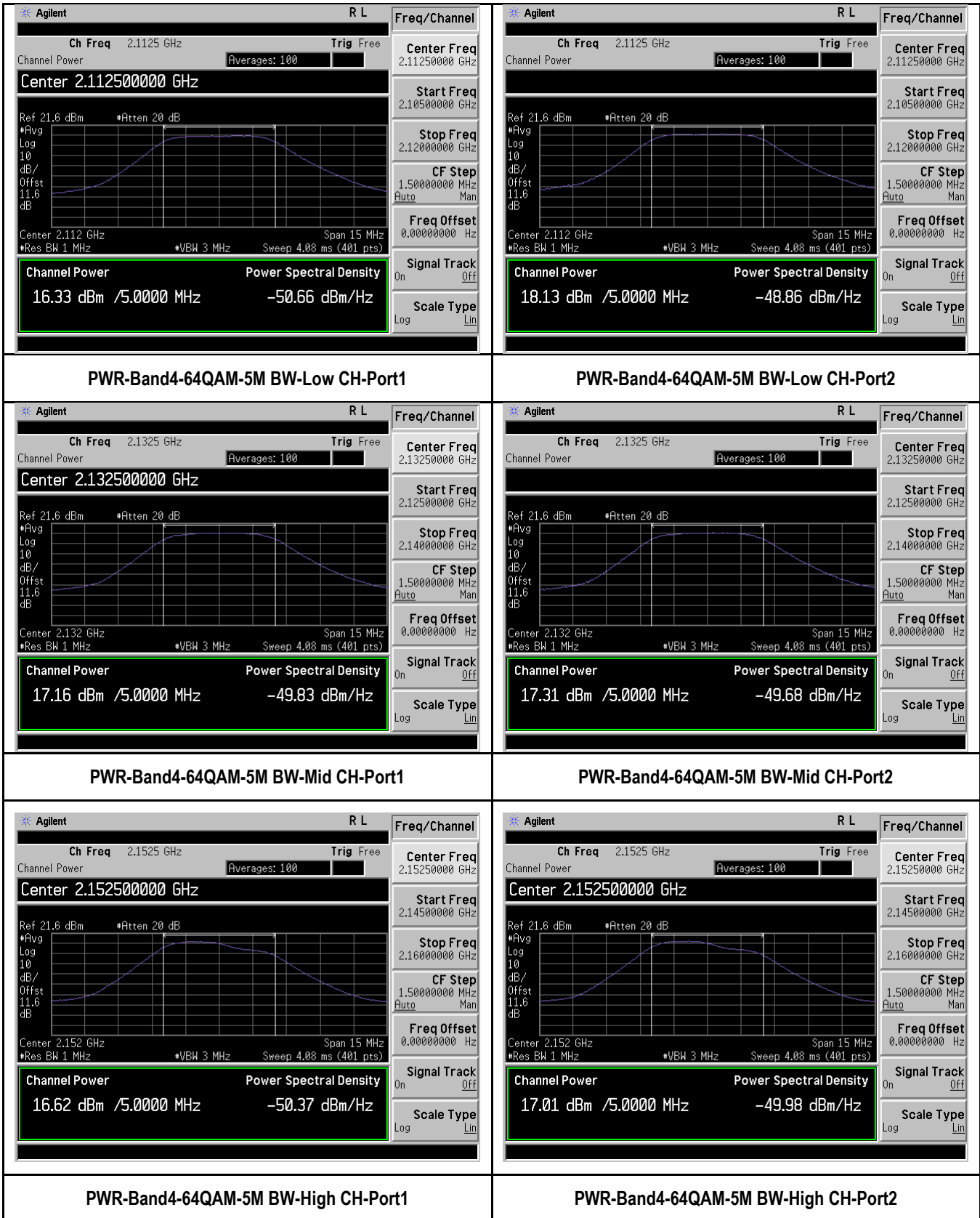

Test Plots for Band 4-QPSK-10MHz

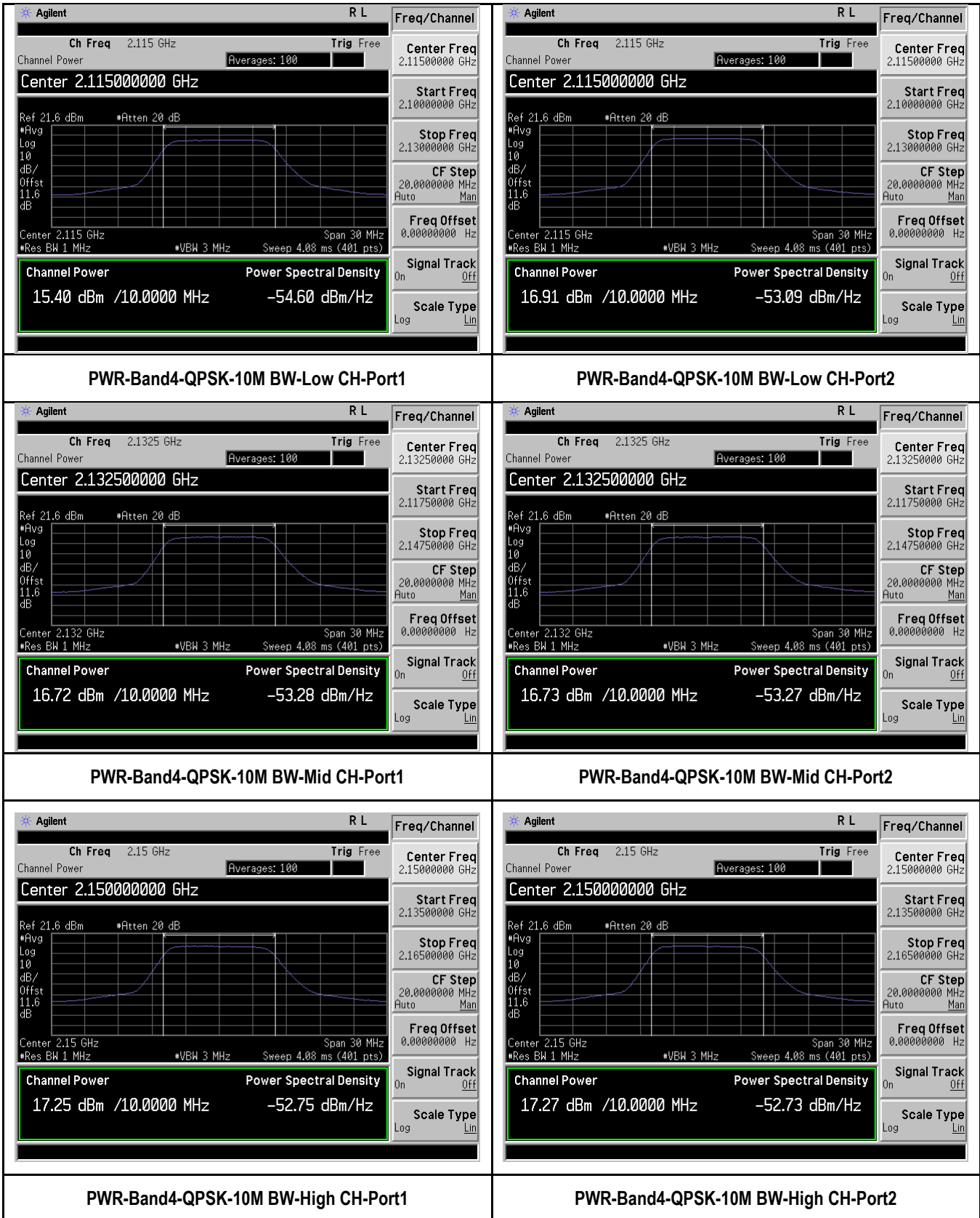

Test Plots for Band 4-64QAM-10MHz

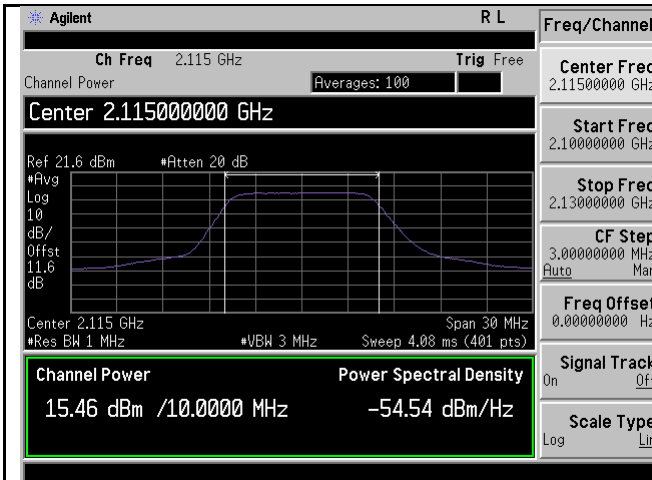

PWR-Band4-64QAM-10M BW-Low CH-Port1

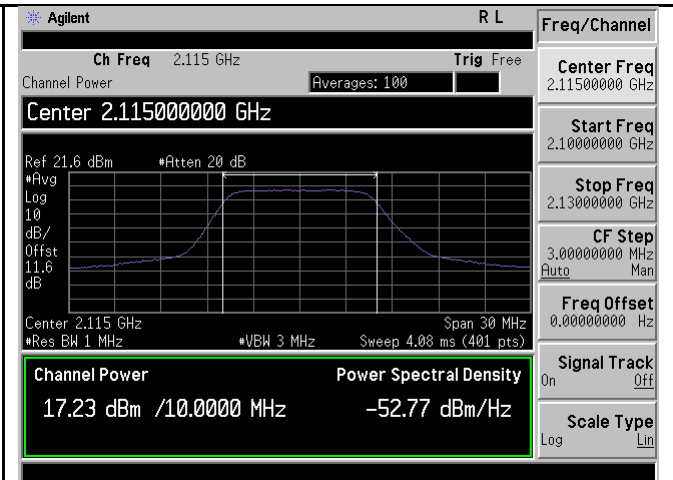

PWR-Band4-64QAM-10M BW-Low CH-Port2

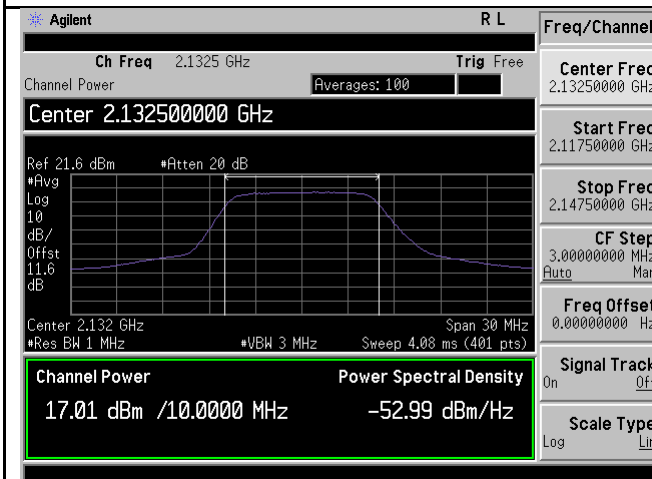

PWR-Band4-64QAM-10M BW-Mid CH-Port1

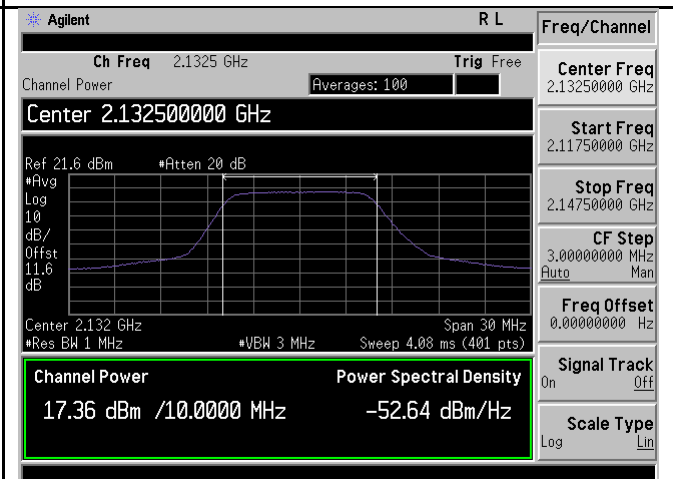

PWR-Band4-64QAM-10M BW-Mid CH-Port2

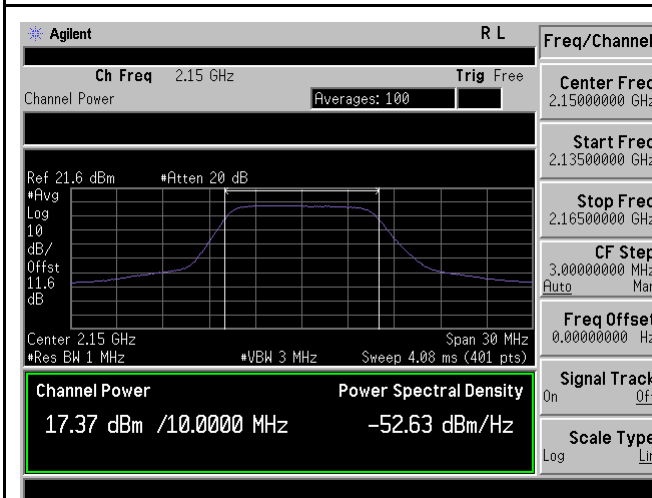

PWR-Band4-64QAM-10M BW-High CH-Port1

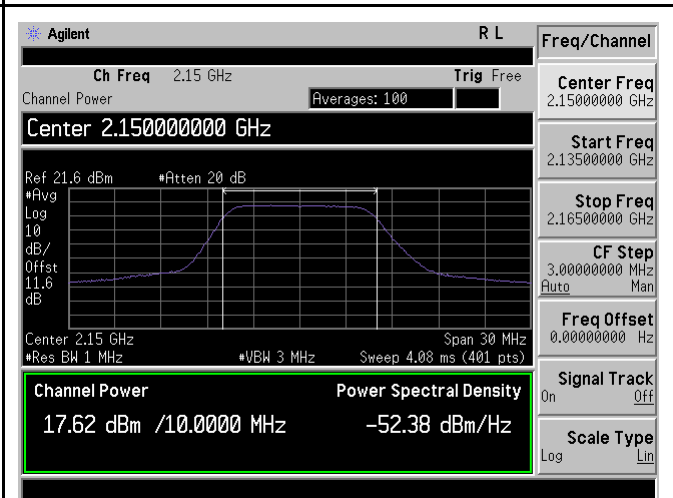

PWR-Band4-64QAM-10M BW-High CH-Port2

Test Plots for Band 4-QPSK-15MHz

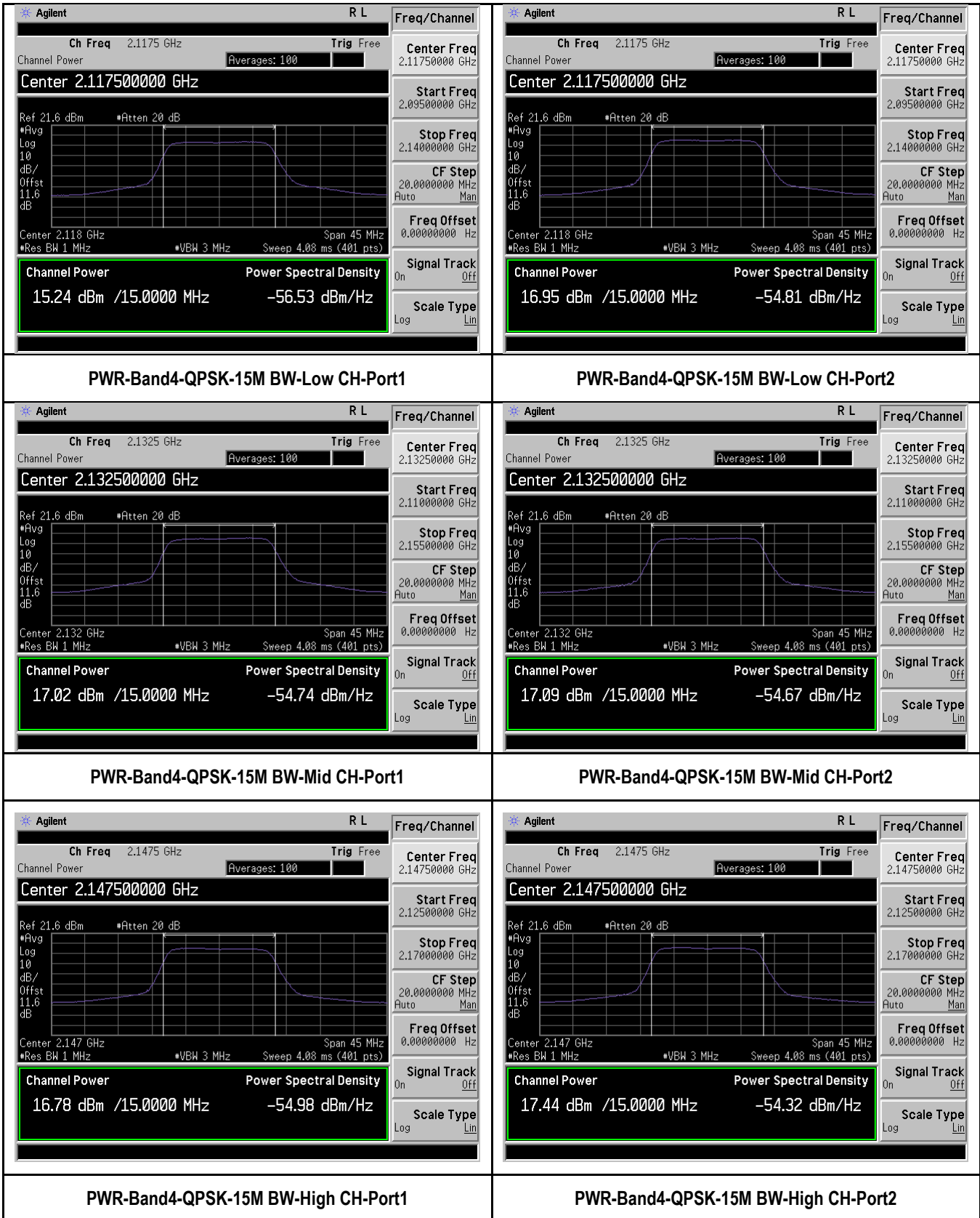

Test Plots for Band 4-64QAM-15MHz

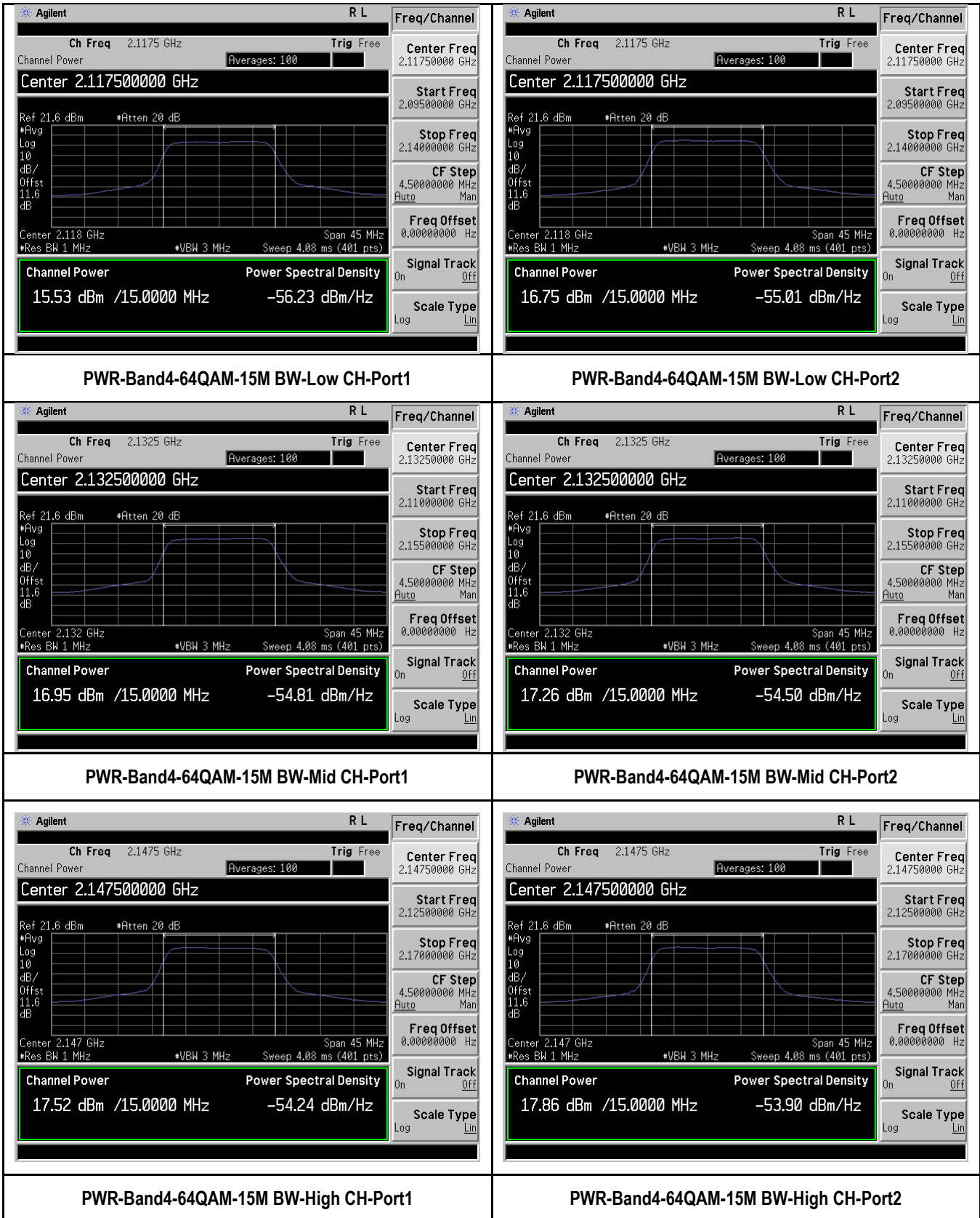

Test Plots for Band 4-QPSK-20MHz

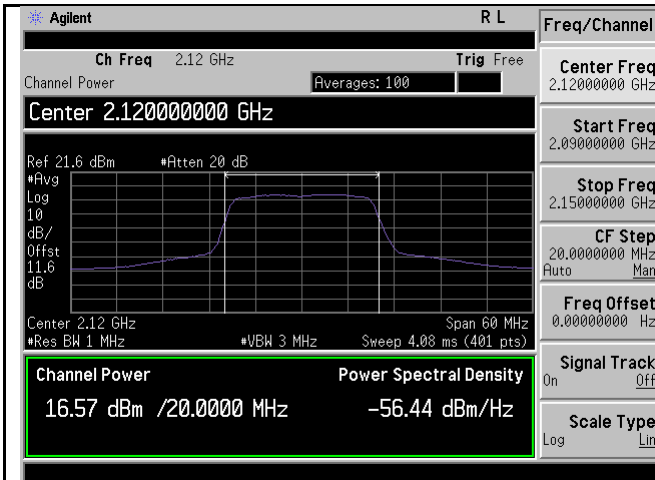

PWR-Band4-QPSK-20M BW-Low CH-Port1

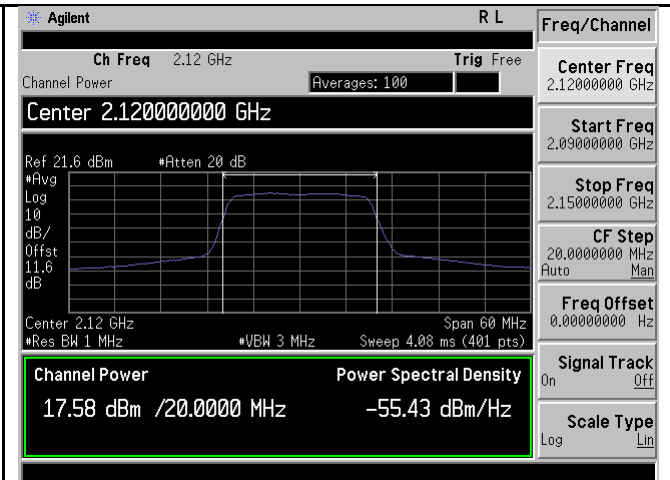

PWR-Band4-QPSK-20M BW-Low CH-Port2

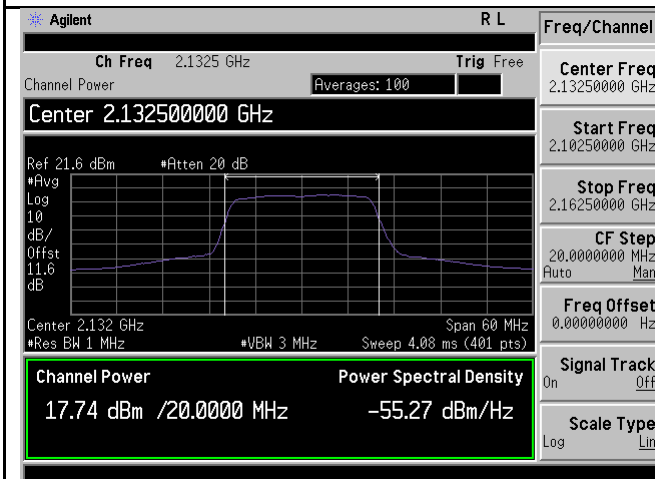

PWR-Band4-QPSK-20M BW-Mid CH-Port1

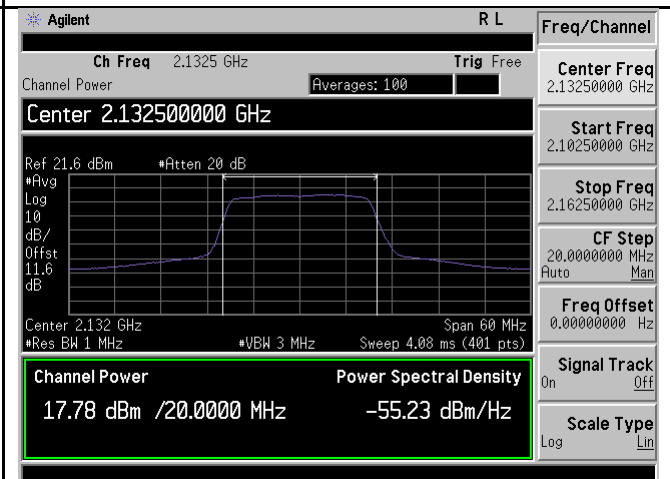

PWR-Band4-QPSK-20M BW-Mid CH-Port2

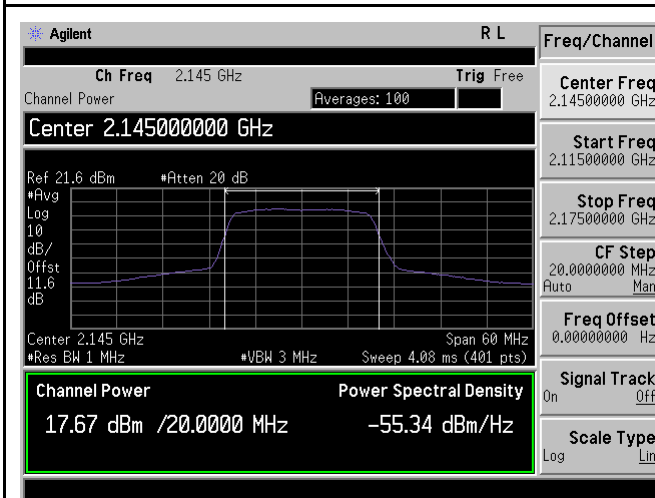

PWR-Band4-QPSK-20M BW-High CH-Port1

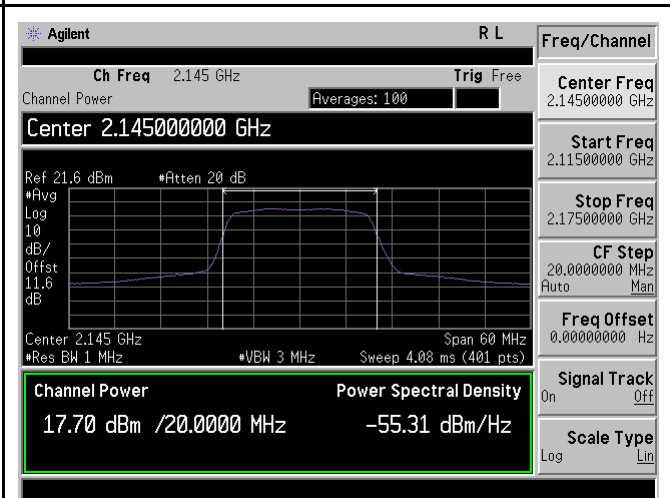

PWR-Band4-QPSK-20M BW-High CH-Port2

Test Plots for Band 4-64QAM-20MHz

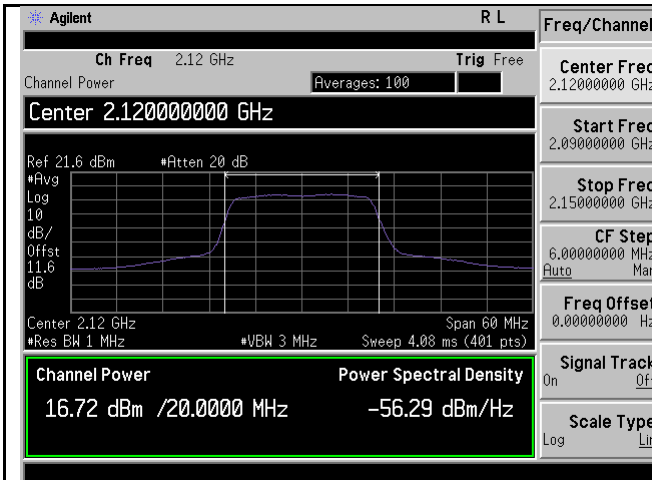

PWR-Band4-64QAM-20M BW-Low CH-Port1

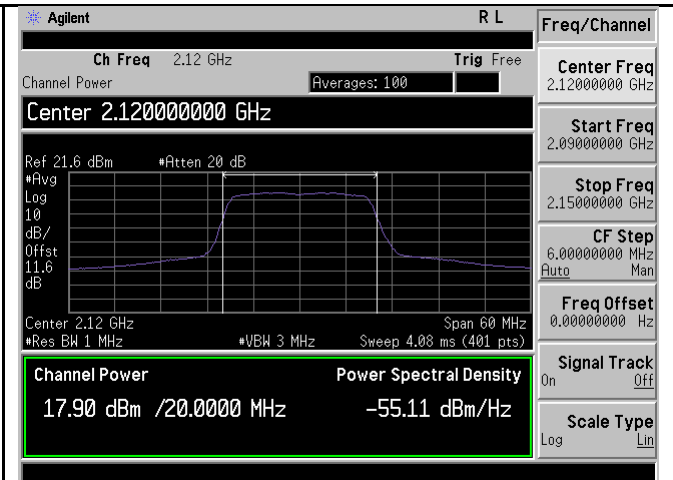

PWR-Band4-64QAM-20M BW-Low CH-Port2

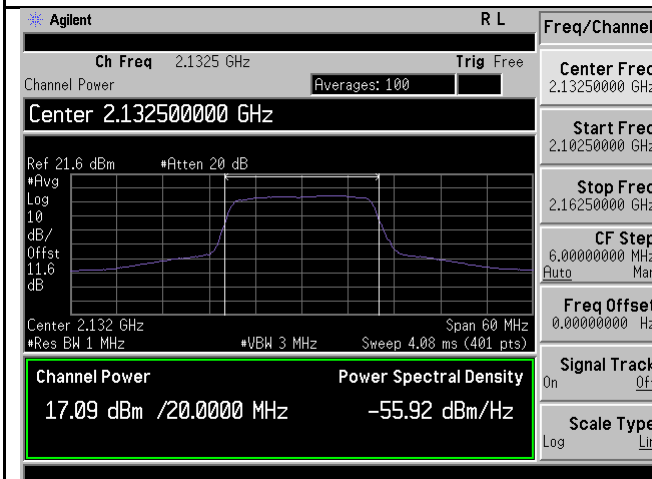

PWR-Band4-64QAM-20M BW-Mid CH-Port1

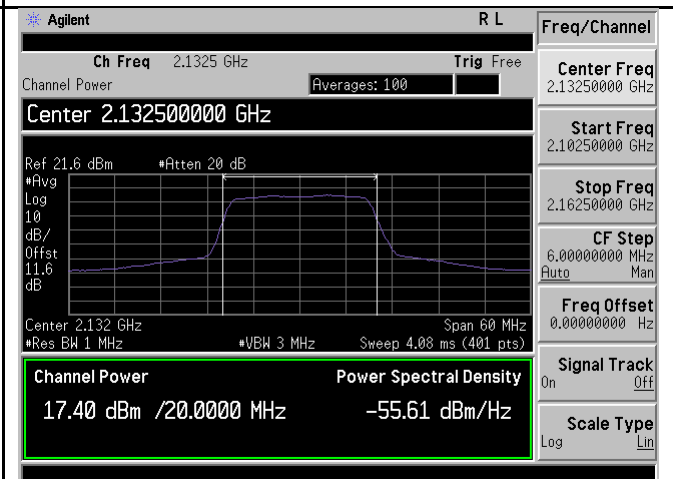

PWR-Band4-64QAM-20M BW-Mid CH-Port2

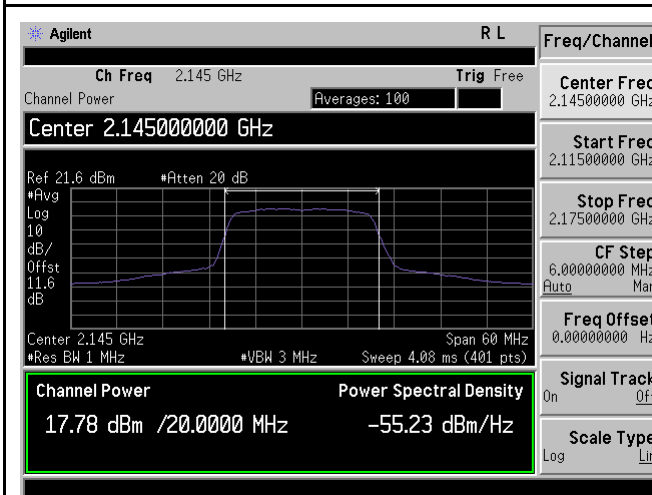

PWR-Band4-64QAM-20M BW-High CH-Port1

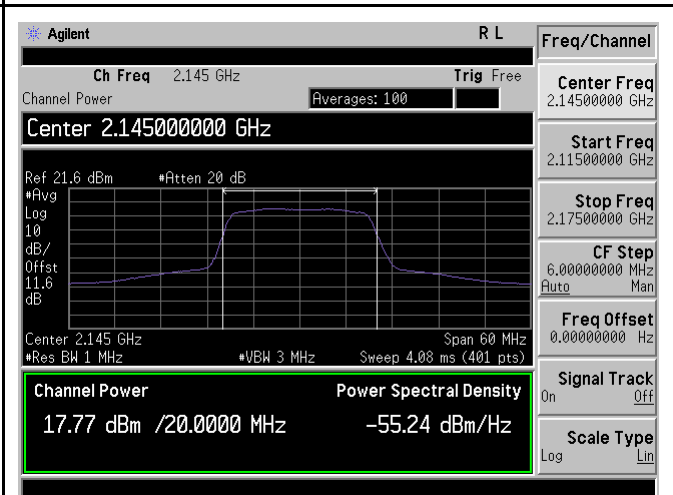

PWR-Band4-64QAM-20M BW-High CH-Port2

Test Plots for Band 12-QPSK-5MHz

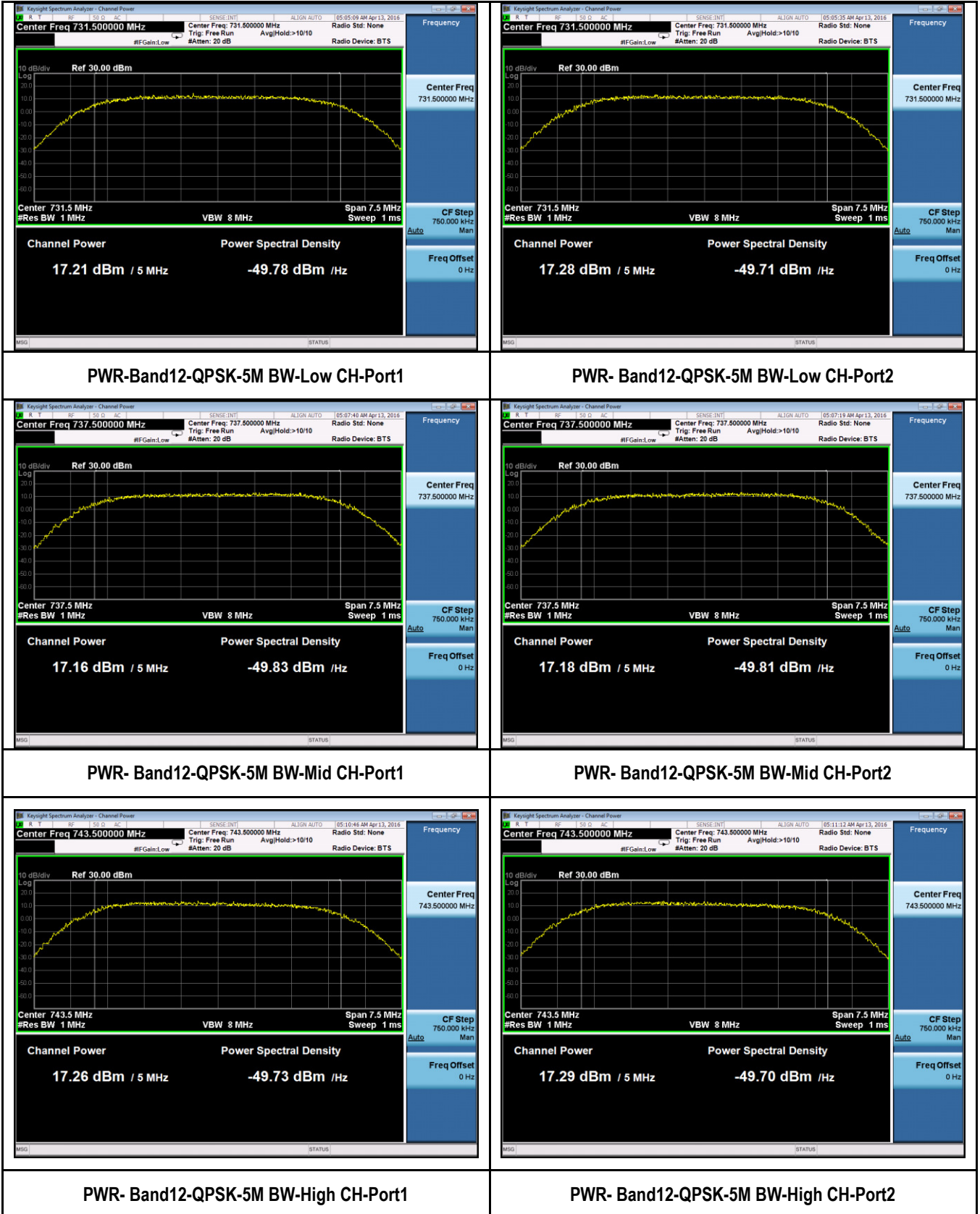

Test Plots for Band 12-64QAM-5MHz

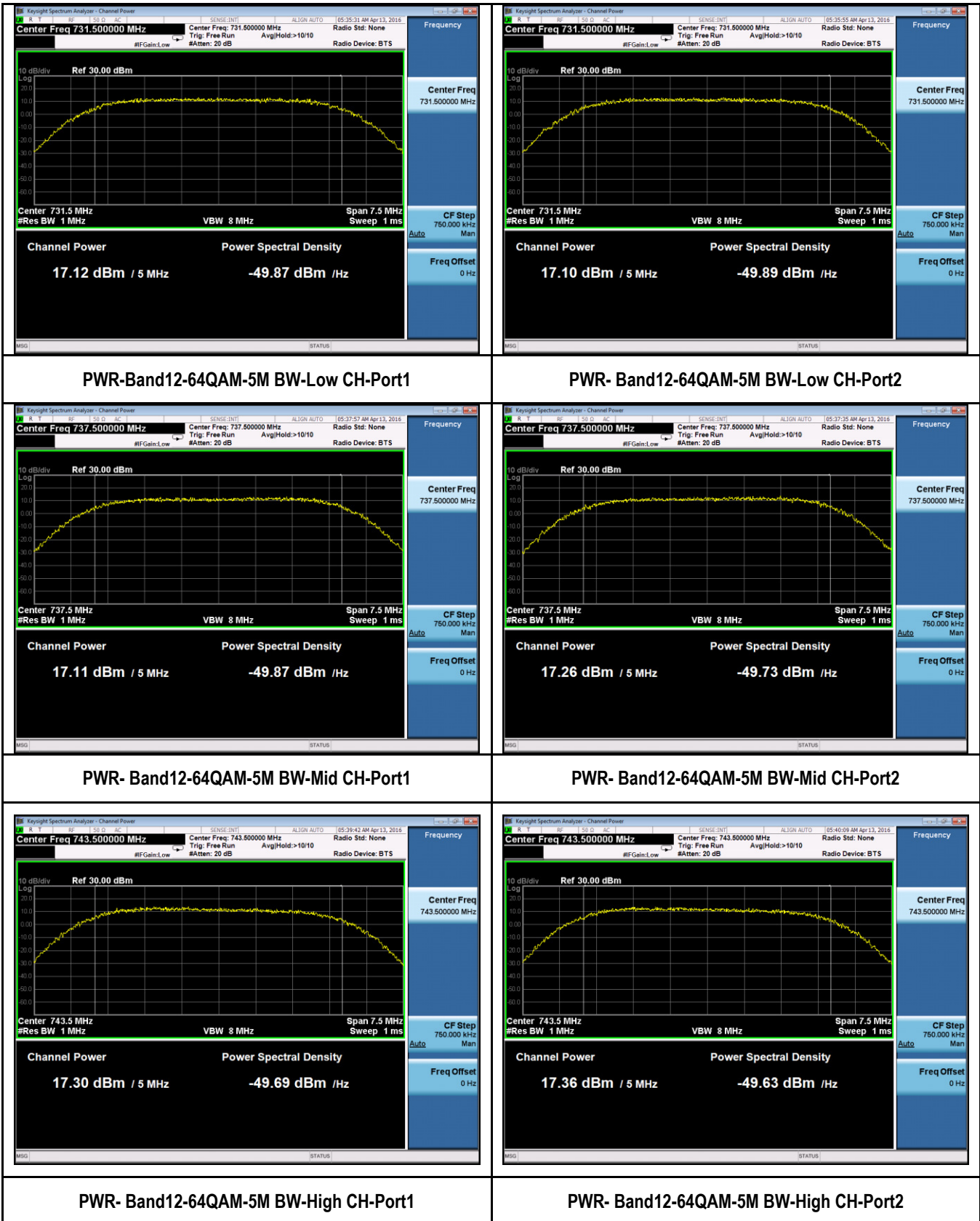

Test Plots for Band 12-QPSK-10MHz

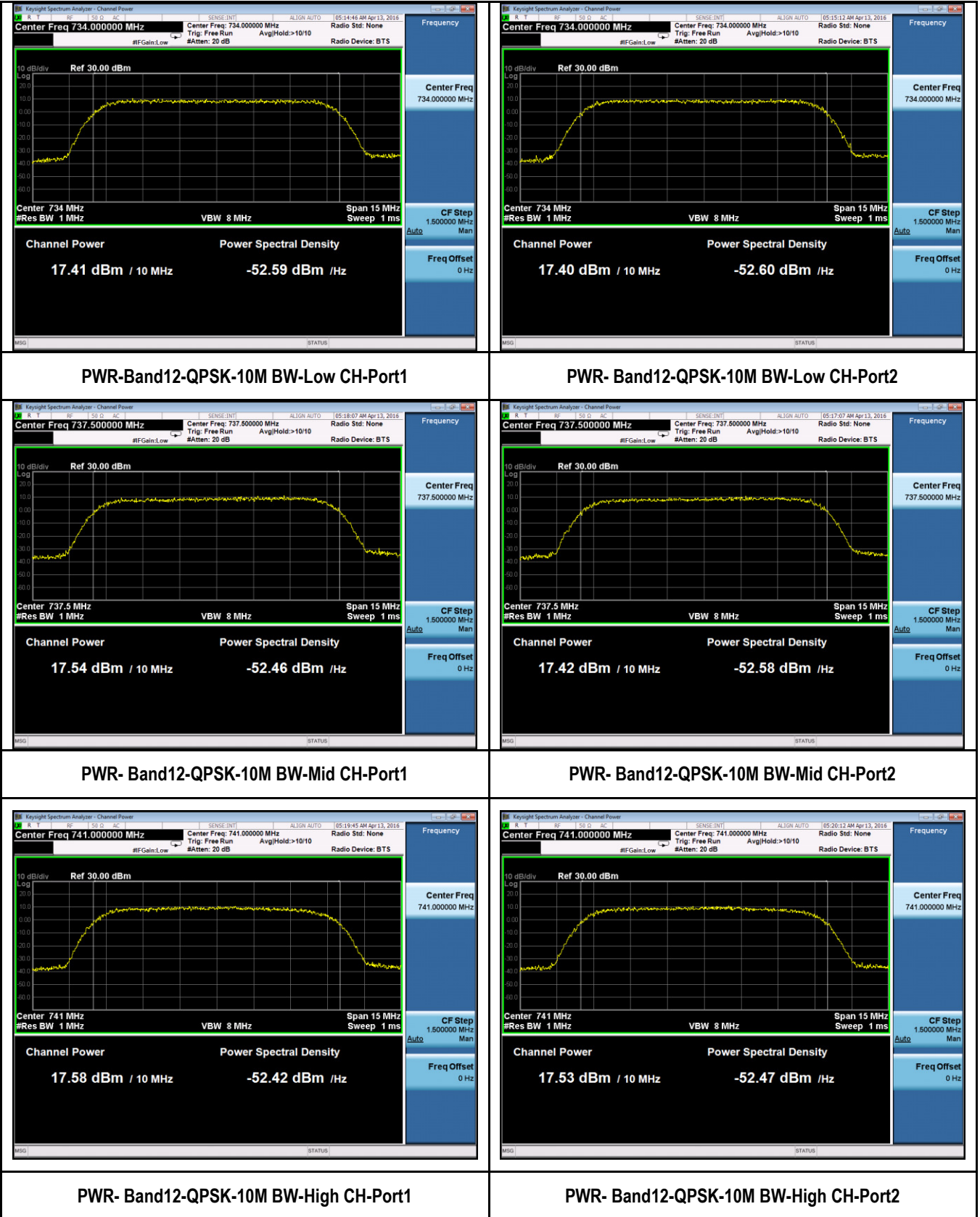

Test Plots for Band 12-64QAM-10MHz

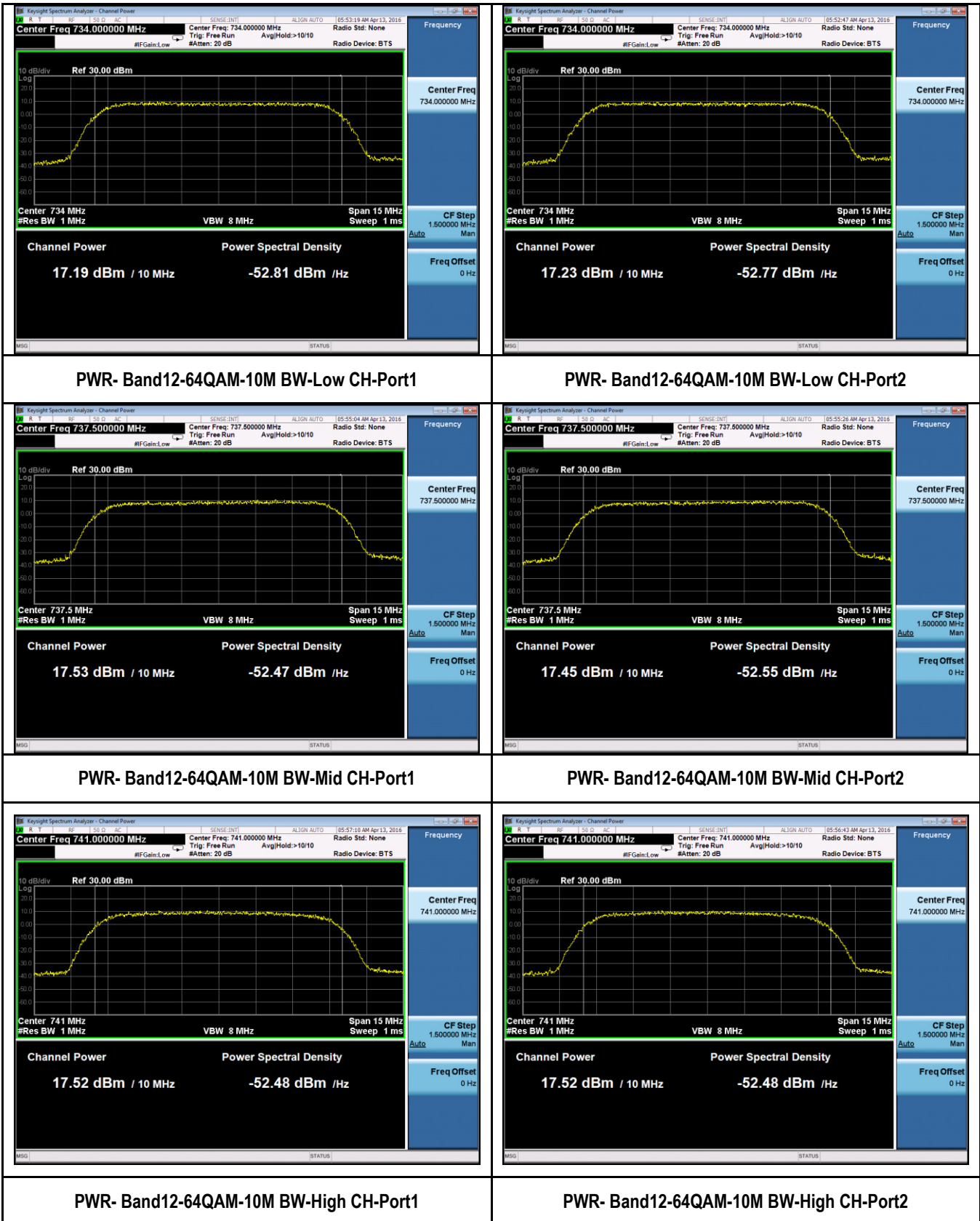

10.2 Peak-Average Ratio

Requirement(s):

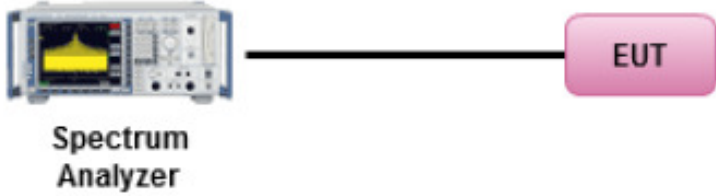
Spec	Item	Requirement	Applicable
47CFR27.50	(b)	The peak-to-average power ratio (PAPR) of the transmitter output power must not exceed 13 dB. The PAPR measurements should be made using either an instrument with complementary cumulative distribution function (CCDF) capabilities to determine that PAPR will not exceed 13 dB for more than 0.1 percent of the time or other Commission approved procedure. The measurement must be performed using a signal corresponding to the highest PAPR expected during periods of continuous transmission.	<input checked="" type="checkbox"/>
Test Setup	 <p style="text-align: center;">Spectrum Analyzer EUT</p>		
Test Procedure	<ul style="list-style-type: none"> - EUT was set for low, mid, high channel with modulated mode and highest RF output power. - The spectrum analyzer was connected to the antenna terminal. 		
Test Date	10/26/2015 – 11/02/2015 04/11/2016 – 04/15/2016	Environmental condition	Temperature 23°C Relative Humidity 48% Atmospheric Pressure 1008mbar
Remark	NONE		
Result	<input checked="" type="checkbox"/> Pass <input type="checkbox"/> Fail		

Test Data Yes N/A

Test Plot Yes (See below) N/A

Test was done by *Chen Ge* at *RF test site*.

Test Data for LTE band 4:

Type	Channel	Frequency (MHz)	Peak-Average Ratio (dB)	Peak-Average Ratio (dB)
5MHz BW, QPSK	Low	2112.5	9.62	13
	Mid	2132.5	9.53	13
	High	2152.5	9.53	13
5MHz BW, 16QAM	Low	2112.5	9.54	13
	Mid	2132.5	9.95	13
	High	2152.5	9.51	13
5MHz BW, 64QAM	Low	2112.5	9.65	13
	Mid	2132.5	9.52	13
	High	2152.5	9.49	13
10MHz BW, QPSK	Low	2115.0	8.94	13
	Mid	2132.5	8.93	13
	High	2150.0	8.87	13
10MHz BW, 16QAM	Low	2115.0	8.98	13
	Mid	2132.5	8.93	13
	High	2150.0	8.93	13
10MHz BW, 64QAM	Low	2115.0	8.94	13
	Mid	2132.5	8.94	13
	High	2150.0	8.91	13
15MHz BW, QPSK	Low	2117.5	9.11	13
	Mid	2132.5	9.01	13
	High	2147.5	9.01	13
15MHz BW, 16QAM	Low	2117.5	8.94	13
	Mid	2132.5	8.82	13
	High	2147.5	8.88	13
15MHz BW, 64QAM	Low	2117.5	9.09	13
	Mid	2132.5	9.02	13
	High	2147.5	9.00	13
20MHz BW, QPSK	Low	2120.0	8.98	13
	Mid	2132.5	8.90	13
	High	2145.0	8.87	13
20MHz BW, 16QAM	Low	2120.0	8.95	13
	Mid	2132.5	8.91	13
	High	2145.0	8.88	13
20MHz BW, 64QAM	Low	2120.0	8.95	13
	Mid	2132.5	8.88	13
	High	2145.0	8.85	13

Test Data for LTE band 12:

Type	Channel	Frequency (MHz)	Peak-Average Ratio (dB)	Peak-Average Ratio (dB)
5MHz BW, QPSK	Low	731.5	10.12	13
	Mid	737.5	10.08	13
	High	743.5	9.97	13
5MHz BW, 64QAM	Low	731.5	9.91	13
	Mid	737.5	9.83	13
	High	743.5	9.75	13
10MHz BW, QPSK	Low	734.0	9.87	13
	Mid	737.5	9.72	13
	High	741.0	9.87	13
10MHz BW, 64QAM	Low	734.0	10.02	13
	Mid	737.5	10.02	13
	High	741.0	9.89	13

Test Plots for LTE band 4:

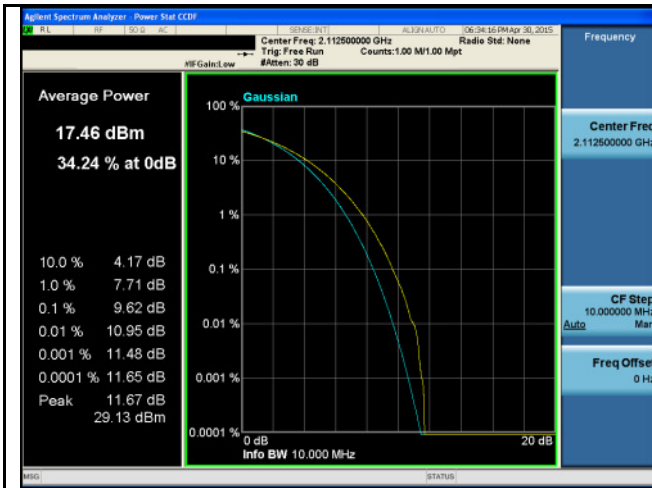

PK-AV-Ratio-Band4-QPSK-5M BW-Low

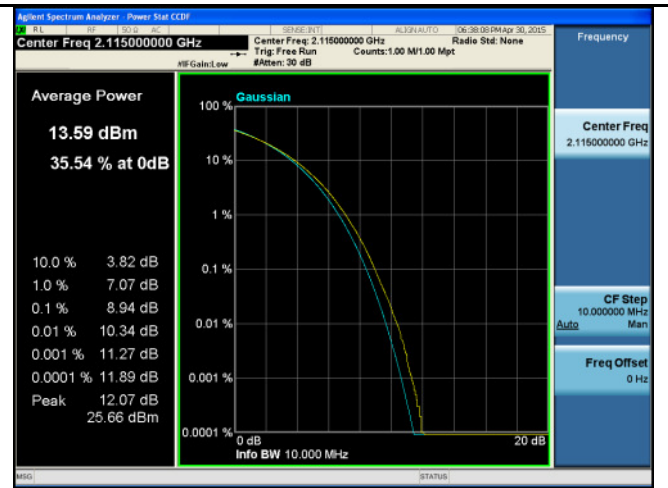

PK-AV-Ratio-Band4-QPSK-10M BW-Low

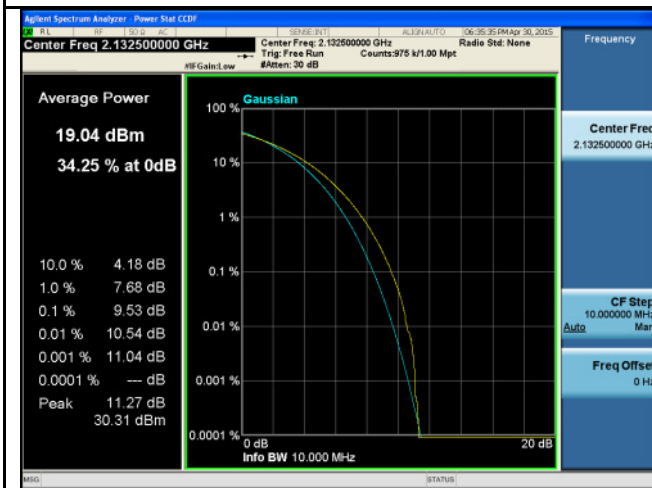

PK-AV-Ratio-Band4-QPSK-5M BW-Mid

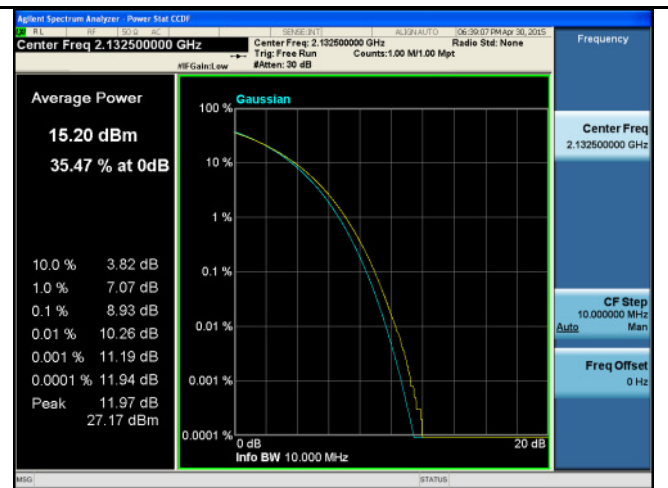

PK-AV-Ratio-Band4-QPSK-10M BW-Mid

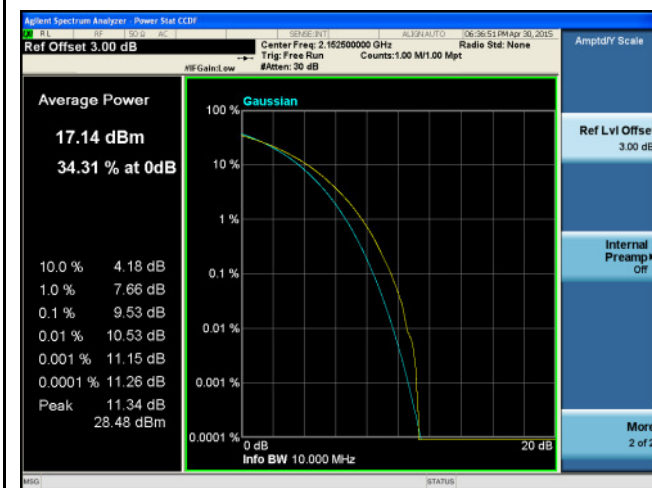

PK-AV-Ratio-Band4-QPSK-5M BW-High

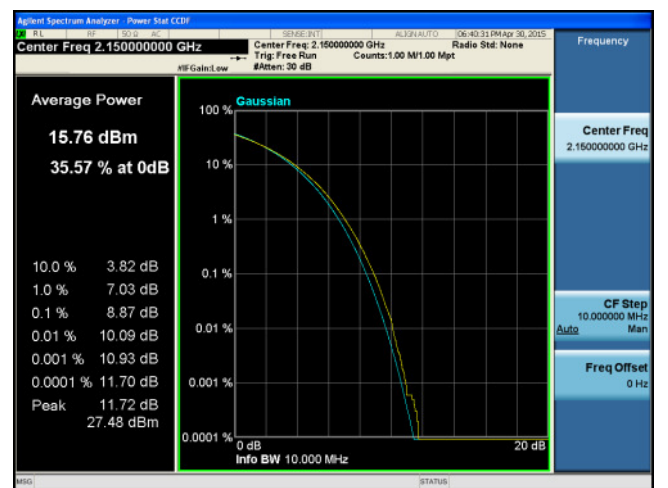

PK-AV-Ratio-Band4-QPSK-10M BW-High

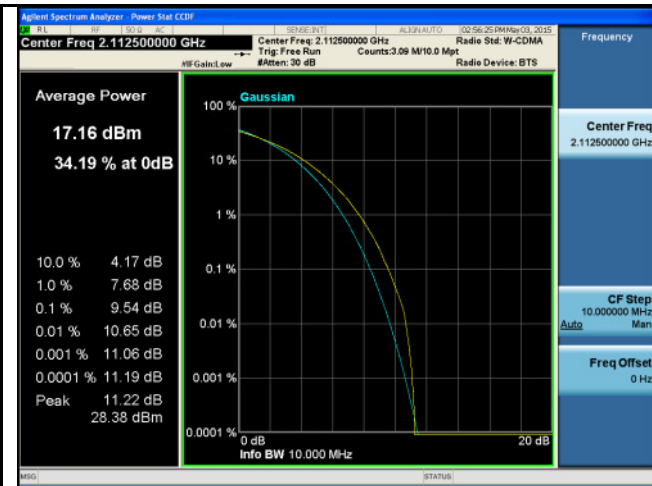

PK-AV-Ratio-Band4-16QAM-5M BW-Low

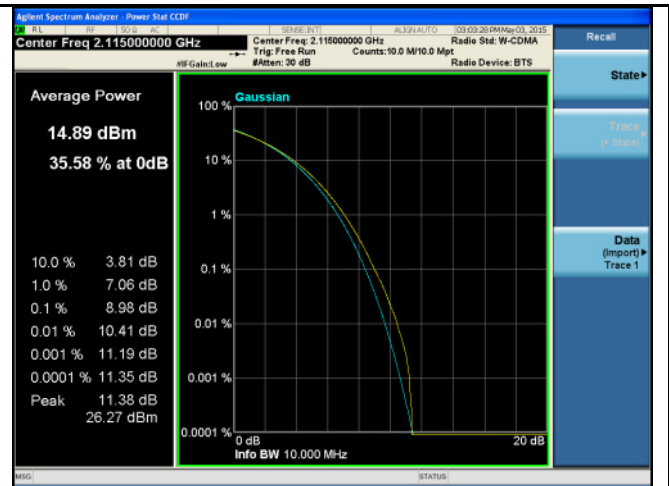

PK-AV-Ratio-Band4-16QAM-10M BW-Low

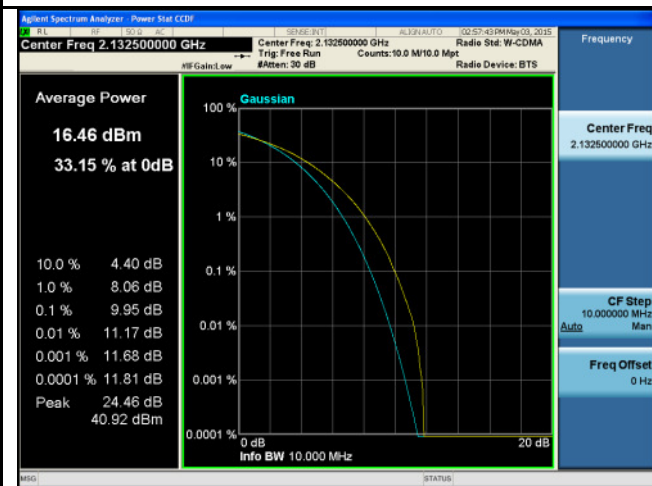

PK-AV-Ratio-Band4-16QAM-5M BW-Mid

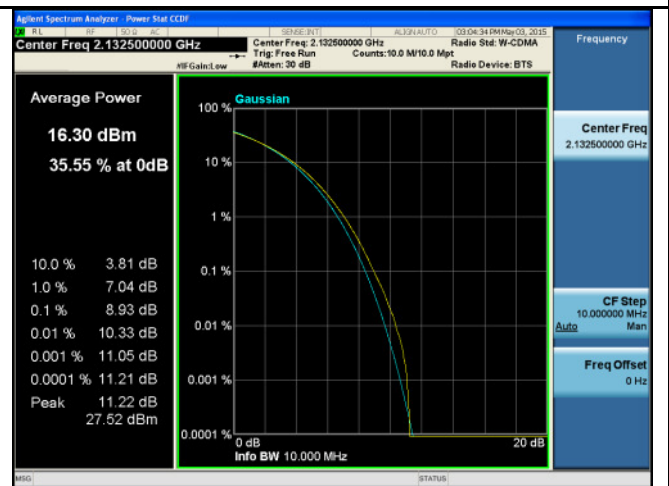

PK-AV-Ratio-Band4-16QAM-10M BW-Mid



PK-AV-Ratio-Band4-16QAM-5M BW-High

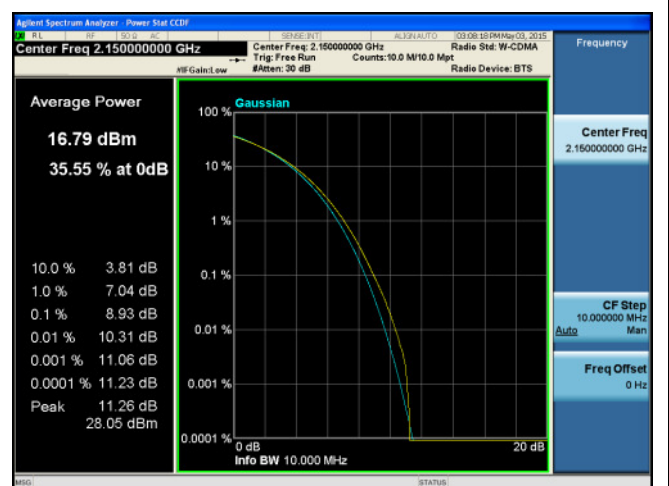

PK-AV-Ratio-Band4-16QAM-10M BW-High