

DCCI CONFIDENTIAL / PRELIMINARY DRAFT

**USER MANUAL
Push Back Gateway**

**U9920-GPB
(P/N: 40993G-01)**

**U9920-GPB(EU)
(P/N: 40993G-02)**

Cautions and Warnings

READ AND SAVE THESE INSTRUCTIONS. Follow the instructions in this installation manual. These instructions must be followed to avoid damage to this product and associated equipment. Product operation and reliability depends on proper usage.



DO NOT INSTALL ANY DAVID CLARK COMPANY PRODUCT THAT APPEARS DAMAGED. Upon unpacking your David Clark product, inspect the contents for shipping damage. If damage is apparent, immediately file a claim with the carrier and notify your David Clark product supplier.



ELECTRICAL HAZARD - Disconnect electrical power when making any internal adjustments or repairs. All repairs should be performed by a representative or authorized agent of the David Clark Company.



STATIC HAZARD - Static electricity can damage components. Therefore, be sure to ground yourself before opening or installing components.



LI-POLYMER - This product is used with Li-Polymer batteries. Do not incinerate, disassemble, short circuit, or expose the battery to high temperatures. Battery must be disposed of properly in accordance with local regulations.

Overview

The U9920-GPB (40993G-01) Push Back Gateway is a portable wireless communication device that when used in conjunction with one or more U9910-BSW (40992G-01) or U9912-BSW Wireless Belt Stations provides communication for up to four users as well as an interface to an aircraft intercom system. Only one gateway is required per system. Up to four belt stations can be connected to one gateway.

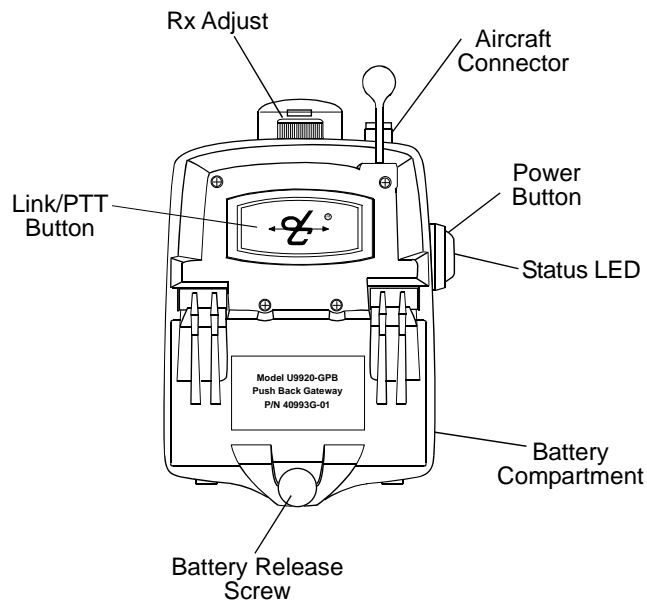

Figure 1: Overview of Gateway

Linking

Before a belt station and a gateway can be connected, they must first be **linked**. As a security measure, the **close-link** feature requires devices to be in proximity of about 1 to 3 ft (0.3 to 0.9m) in order to successfully link. This ensures that the units are not inadvertently linked with other units on the premises.

Linking procedure:

1. Ensure power is on for both U9920-GPB and belt station (see **Power-up/Power-down**)
2. Ensure units are within 1 to 3 ft (0.3 to 0.9m) of each other.
3. Simultaneously (within 1-2 sec) press and release the PTT button on the U9920-GPB and the belt station to link with.
4. Amber LED's will flash on both devices. A momentary red LED indicates a successful close-link.
5. Upon successful link the U9920-GPB will attempt to establish a connection with the belt station.
6. Upon successfully establishing connection the LED on the gateway will flash a green pattern corresponding to the number of belt stations connected.

Tip:

Once linked, the devices will not need to be linked again unless they are purged (see **Purging**).

Each belt station is able to be linked to only one gateway at a time. A gateway can have up to six belt stations linked and be connected to four of those six at one time.

Status Indications

The power button has a multi-color LED in the center which serves as a status indication for the gateway. **Table 1** below lists these states.

Table 1: LED Status Indications

LED Color	Blink Rate	Status
Red	Solid	Initializing/power up
Red	Once	Connection Dropped
Red	Once	Connection Established
Red	Any	Low battery (approx. 1 hr remaining)
Orange	Slow	Idle/Disconnected
Orange	Fast	Link/Connection in Progress
Orange	Solid	PTT asserted
Green	Slow	Connected (pattern indicates number of belt stations connected)

Operation

Power-Up/Power-Down

To power up the U9920-GPB Push Back Gateway, press and hold the POWER button for approximately two seconds. The LED will turn red and then begin flashing orange. If there are linked belt stations within range, they will automatically connect to the gateway in a few seconds after power up.

To power down the U9920-GPB, press and hold the POWER button for approximately two seconds. The LED will turn red and then turn off. The gateway is now powered down.

Aircraft Interface

The U9920-GPB is designed for airport push back operations and can be connected to an aircraft intercom system. Once connected, up to four belt station (U9910-BSW) users can communicate to the pilot of the aircraft by pressing the PTT button on the belt station. A Push Back Cable is required between the U9920-GPB and the aircraft (cable P/N: 41035G-02 included with gateway, standard 1/4" interphone connection). See **Figure 2** below.

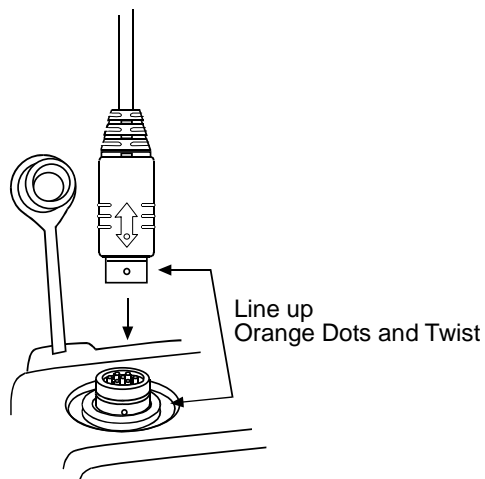

Figure 2: Push Back Cable Connection

[additional figure showing aircraft interface]

Aircraft Level Adjustment

Audio levels can vary between aircraft. To compensate for this, the U9920-GPB has a receive level adjust knob (see **Figure 1**). Turning this knob will increase or decrease the audio level coming from the aircraft and into the wireless intercom. By adjusting this knob, optimum performance can be achieved.

Receive Level Adjustment Procedure

1. Connect at least one belt station to the U9920-GPB gateway and ensure sidetone is present (see belt station User Manual).
2. Press and hold PTT
3. While holding PTT, begin speaking and slowly turn Receive Level Adjust knob on the U9920-GPB gateway *clockwise* until you hear an echo of your own voice.
4. Turn the Receive Level Adjust knob slightly *counter-clockwise* until the echo stops.
5. Release PTT.
6. You may wish to verify communication with the pilot or someone hard-wired to the aircraft's intercom.

Communication

Note: It is highly recommended for wireless push-back systems that each headset user interface through a non-VOX belt station (U9912-BSW), as extremely high and varying noise levels within this environment can become challenging to the VOX feature, resulting in unwanted ramp noise being present in a VOX belt station user's headset and causing him/her to frequently adjust the VOX setting. VOX belt stations may be desired in more stable and less extreme noise environments.

All connected belt stations will be able to communicate with each other through the U9920-GPB while in range. Additionally, all belt station users will always hear any traffic on the aircraft intercom. To speak over the aircraft intercom, the belt station user must press and hold his/her PTT button. Multiple belt station users may PTT and thus speak over the aircraft intercom simultaneously. Wireless intercom for all connected belt station users is also achieved in this manner. For more information consult the user manual for the belt station.

Range

The range of a belt station and a gateway can be up to 300 ft (100m). If you are in an environment with metal or concrete walls, this range could be reduced. When the belt station travels out of range of the gateway, a voice alert will indicate that the connection has been lost. To reconnect, simply move back into range and connection with the gateway will automatically be reestablished, also noted by a voice alert.

Low Battery

Under typical conditions, the battery in the gateway will last up to 24 hours or longer. The Status LED turns red to indicate that the battery is running low. At this point, approximately 1 hour of operation remains.

Purging

In some circumstances it may be necessary to “purge” the U9920-GPB of some of its linked belt stations. Typically purging is not necessary unless there are multiple gateways in the same vicinity and you wish to remove a belt station from this gateway and link to a different gateway. A gateway can link up to six belt stations where a belt station can be linked to only one gateway at a time.

Full Purge

A *full purge* is the purge method employed by the U9920-GPB and clears all links in the gateway. After this procedure no belt stations will automatically connect to this gateway until linked.

Full Purge procedure

1. Power down gateway (see **Power-up/Power-down**).
2. Press and hold PTT button. Do not release.
3. Power up the gateway (see **Power-up/Power-down**).
4. Release POWER button.
5. Release PTT button.
6. Status LED will flash red to indicate successful purge.

Battery Removal & Charging

All David Clark 9900-series wireless belt stations and battery operated controllers/gateways use a 3.7V Li-Polymer rechargeable battery. This battery is removed by loosening the battery release screw (See **Figure 1**). The batteries are charged with the A99-04CRG 4-bay battery charger (41034G-01).

When installing a battery, take care to align the battery properly and fully tighten the screw (see **Figure 3**).

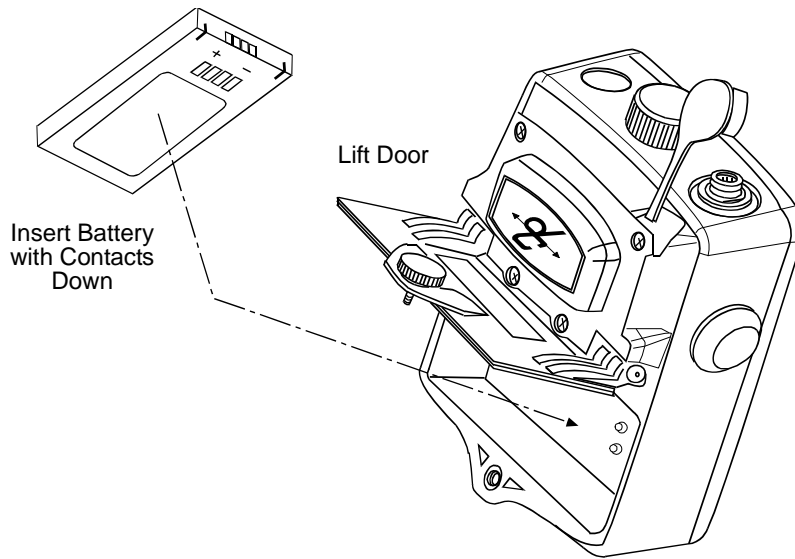

Figure 3: Battery Insertion/Removal

Troubleshooting

Table 2: Troubleshooting

Problem	Solution
Gateway will not turn on	Review <i>Power-up/Power-down</i> procedure Ensure a fresh battery is installed
Cannot link a belt station	Review <i>Registration</i> procedure Ensure units are within 1 to 3ft (0.3 to 0.9m) of each other Try a <i>Full Purge</i>
Cannot speak to aircraft	PTT not pressed

Replacement Parts

- Battery (P/N: 40688G-90)
- Protective skin, orange (A99-02SKN, P/N: 40796G-03)
- Aircraft Interface Cord, PJ-051 {1/4" plug} (P/N: 41035G-02)
- Aircraft Interface Cord, U-174 plug {Embraer} (P/N: 41035G-03)
 - Note: NOT for military aircraft (*consult factory*)
- Aircraft Interface Cord, dual General Aviation plugs {Saab, others} (P/N: 41035G-04)

Care and Maintenance

The U9920-GPB is not user serviceable. Do not attempt to open the enclosure. If this product requires service, please contact the David Clark Co. Inc. Customer Service department:

- **Phone:** 800.298.6235
- **E-Mail:** serviceWWW@DavidClark.com
- **By Mail:** Customer Service
David Clark Company
360 Franklin Street
Worcester, MA 01604

If necessary, the U9920-GPB may be wiped down with a mild soap and water mixture. Although it is a sealed device designed to withstand submersion in water to 1 meter, do not unnecessarily submerge this product in water.

Avoid storage of this product in direct sunlight or high temperature environments.

Specifications

Frequency Range	1920 MHz - 1930 MHz (U.S. and Canada) 1880 MHz - 1900 MHz (EU)
Average RF Power Output	4 mW (100mW peak) (U.S. and Canada) 10 mW (250 mW peak) (EU)
Range	300 ft (100m) line-of-sight (nominal)
Battery Life	24 hrs continuous use (nominal)
Operating Temperature	-14°F to 113°F (-10°C to +45°C)
Storage Temperature	-4°F to 140°F (-20°C to +60°C)
Power Requirements	3.7V @ 100mA nominal
Battery Type	3.7V 2000mAh Li-Polymer

FCC Part 15 Statement

RADIO AND TELEVISION INTERFERENCE

This equipment has been tested and found to comply with the limits for a Class B digital device, pursuant to Part 15 of the FCC rules. These limits are designed to provide reasonable protection against harmful interference in a residential installation. This equipment generates, uses and can

radiate radio frequency energy and, if not installed and used in accordance with the instructions, may cause harmful interference to radio communications. However, there is no guarantee that interference will not occur in a particular installation. If this equipment does cause harmful interference to radio or television reception, which can be determined by turning the equipment off and on, the user is encouraged to try to correct the interference by one or more of the following measures:

- Reorient or relocate the receiving antenna.
- Increase the separation between the equipment and the receiver.
- Connect the equipment into an outlet on a circuit different from that to which the receiver is connected.
- Consult the dealer or an experienced radio/TV technician for help.

You may also find helpful the following booklet, prepared by the FCC: "How to Identify and Resolve Radio-TV Interference Problems." This booklet is available from the U.S. Government Printing Office, Washington D.C. 20402.

* In order to maintain compliance with FCC regulations shielded cables must be used with this equipment. Operation with non-approved equipment or unshielded cables is likely to result in interference to radio & television reception.

Industry Canada Statement

This device complies with Industry Canada licence-exempt RSS standard(s). Operation is subject to the following two conditions: (1) this device may not cause interference, and (2) this device must accept any interference, including interference that may cause undesired operation of the device.

Unauthorized Changes

Changes or modifications not expressly approved by David Clark Company, Inc. could void the users' authority to operate the equipment.

Usage Restrictions

US Models

Due to the UPCS frequencies used, this product is licensed for operation only in the United States of America and Canada.

EU Models

Due to the DECT frequencies used, this product is licensed for operation only in the European Union countries.