

DCCI CONFIDENTIAL / PRELIMINARY DRAFT

**USER MANUAL
Controller Belt Station**

**U9911-BSC
(P/N: 41033G-01)**

**U9911-BSC(EU)
(P/N: 41033G-02)**

Cautions and Warnings

READ AND SAVE THESE INSTRUCTIONS. Follow the instructions in this installation manual. These instructions must be followed to avoid damage to this product and associated equipment. Product operation and reliability depends on proper usage.



DO NOT INSTALL ANY DAVID CLARK COMPANY PRODUCT THAT APPEARS DAMAGED. Upon unpacking your David Clark product, inspect the contents for shipping damage. If damage is apparent, immediately file a claim with the carrier and notify your David Clark product supplier.



ELECTRICAL HAZARD - Disconnect electrical power when making any internal adjustments or repairs. All repairs should be performed by a representative or authorized agent of the David Clark Company.



STATIC HAZARD - Static electricity can damage components. Therefore, be sure to ground yourself before opening or installing components.



LI-POLYMER - This product is used with Li-Polymer batteries. Do not incinerate, disassemble, short circuit, or expose the battery to high temperatures. Battery must be disposed of properly in accordance with local regulations.

Overview

The U9911-BSC (41033G-01) Controller Belt Station is a portable wireless communication device that when used in conjunction with one or more U9910-BSW (40992G-01) or U9912-BSW (40992G-02) Wireless Belt Stations becomes part of a wireless intercom system. Up to five users are able to communicate with each other when using the U9911-BSC. Only one controller is required per system. Up to four belt stations can be connected to one controller.

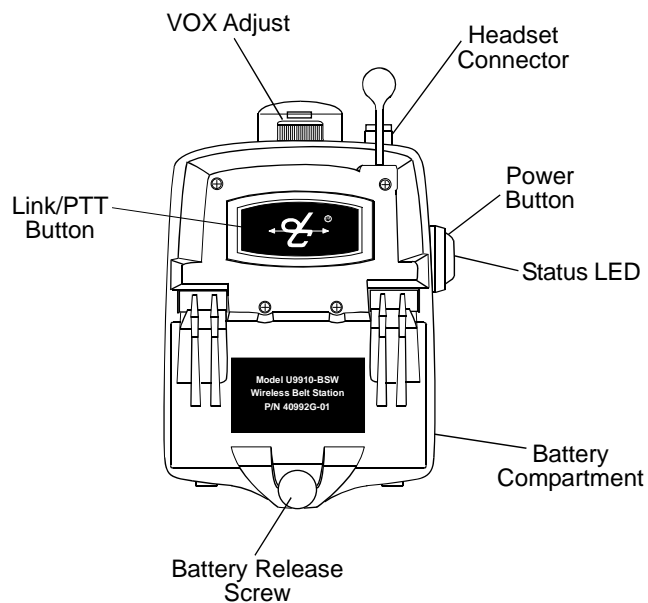

Figure 1: Overview of Controller

Linking

Before a belt station and a controller can be connected, they must first be **linked**. As a security measure, the **close-link** feature requires devices to be in proximity of about 1 to 3 ft (0.3 to 0.9m) in order to successfully link. This ensures that the units are not inadvertently linked with other units on the premises.

Linking procedure:

1. Ensure power is on for both U9911-BSC and belt station (see **Power-up/Power-down**).
2. Ensure units are within 1 to 3 ft (0.3 to 0.9m) of each other.
3. Simultaneously (within 1-2 sec) press and release the PTT button on the U9911-BSC and the belt station to link with.
4. Amber LED's will flash on both devices. A momentary red LED indicates a successful close-link.
5. Upon successful link the U9910-BSC will attempt to establish a connection with the belt station.
6. Upon successfully establishing connection the LED on the controller will flash a green pattern corresponding to the number of belt stations connected.

Tip:

Once linked, the devices will not need to be linked again unless they are purged (see **Purging**).

Each belt station is able to be linked to only one controller at a time. A controller can have up to six belt stations linked and be connected to four of those six at one time.

Status Indications

The power button has a multi-color LED in the center which serves as a status indication for the controller. **Table 1** below lists these states.

Table 1: LED Status Indications

LED Color	Blink Rate	Status
Red	Solid	Initializing/power up
Red	Once	Connection Dropped
Red	Once	Connection Established
Red	Any	Low battery (approx. 1 hr remaining)
Orange	Slow	Idle/Disconnected
Orange	Fast	Link/Connection in Progress
Orange	Solid	PTT asserted
Green	Slow	Connected (pattern indicates number of belt stations connected)

In addition to the LED, the belt station provides audio feedback for certain conditions as well. **Table 2** below lists these conditions.

Table 2: Voice Alerts

Voice Alerts
“Connection Established”
“Connection Lost”
“Low Battery”
“Connection Deleted” (see Purging)

Operation

Power-up/power-down

To power up the U9911-BSC controller belt station, press and hold the POWER button for approximately two seconds. The LED will turn red and then begin flashing orange. If there are linked belt stations within range, they will automatically connect to the controller in a few seconds after power up.

To power down the U9910-BSC, press and hold the POWER button for approximately two seconds. The LED will turn red and then turn off. The controller is now powered down.

Headset

In order for the U9911-BSC to be used, a David Clark H9900-series headset must be connected. To connect the headset, align the connectors as shown then push and turn clockwise (see **Figure 2**). There are separate left and right volume controls on the headset.

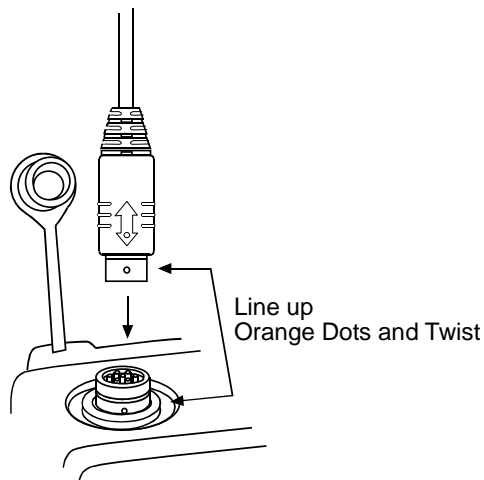

Figure 2: Headset Connection

It is also important to properly wear the headset and correctly position the microphone. For optimum noise-cancelling performance, position the microphone 1/8" to 1/4" (3-6 mm) from your lips.



Figure 3: Wearing the Headset

VOX adjustment

The U9911-BSC has an innovative voice activation (VOX) system. VOX is intended to prevent background noise from being unintentionally picked up by the microphone while detecting and allowing voice communications. The VOX knob (see **Figure 1**) controls the threshold at which the mic becomes "hot". When the mic is hot you will hear your own voice and other connected users will hear you as well. Pressing the PTT button will automatically make the microphone "hot" for as long as the PTT is held down, regardless of VOX setting.

VOX Basics

- VOX knob fully clockwise (CW): Mic is off
- VOX knob fully counter-clockwise (CCW): Mic is "hot"
- VOX knob in-between full CW and full CCW: VOX enabled

VOX Adjustment Procedure

1. Ensure that the controller is linked with a belt station (LED flashing green).
2. Stand in the noisy environment where you will be using the system but do not speak.
3. Turn VOX knob fully counter-clockwise. You will hear a continuous tone.
4. While continuing not to speak, slowly turn the VOX knob clockwise until the tone stops.
5. VOX is now optimally set for your environment.

If you move to another location, you may wish to repeat the above procedure.

Tip:

- Turning the VOX knob fully clockwise will turn off the microphone.
- Conversely, turning the VOX knob fully counter-clockwise will cause the microphone to be “hot” all the time.

Communication

The user will hear his own voice (side-tone) only when the controller is connected to a belt station and VOX is properly adjusted. Side-tone provides feedback for the user to know he is connected and is being heard by the remote users as well. In general, if you can hear your own voice, the other users can hear you as well.

Range

The range of a belt station and a controller can be up to 300 ft (100m). If you are in an environment with metal or concrete walls, this range could be reduced. When the belt station travels out of range of the controller, a voice alert will indicate that the connection has been lost. To reconnect, simply move back into range and connection with the controller/gateway will automatically be reestablished, also noted by a voice alert.

Low Battery

Under typical conditions, the battery in the controller will last up to 24 hours or longer. A voice alert will indicate to the user that the battery is running low. Additionally the Status LED will turn red. At this point, approximately 1 hour of operation remains.

Purging

In some circumstances it may be necessary to “purge” the U9911-BSC of its linked belt stations. Typically purging is not necessary unless there are multiple controllers in the same vicinity and you wish to remove a belt station from this controller and link to a different controller. A controller can link up to six belt stations where a belt station can be linked to only one controller at a time.

Full Purge

A *full purge* is the purge method employed by the U9911-BSC and clears all links in the controller. After this procedure no belt stations will automatically connect to this controller until linked.

Full Purge procedure

1. Power down controller (see **Power-up/Power-down**).
2. Press and hold PTT button. Do not release.
3. Power up the controller (see **Power-up/Power-down**).
4. Release POWER button.
5. Release PTT button.

Battery Removal & Charging

All David Clark 9900-series wireless belt stations and battery operated controllers use a 3.7V Li-Polymer rechargeable battery. This battery is removed by loosening the battery release screw (See **Figure 1**). The batteries are charged with the A99-04CRG 4-bay battery charger (41034G-01).

When installing a battery, take care to align the battery properly and fully tighten the screw (see **Figure 3**).

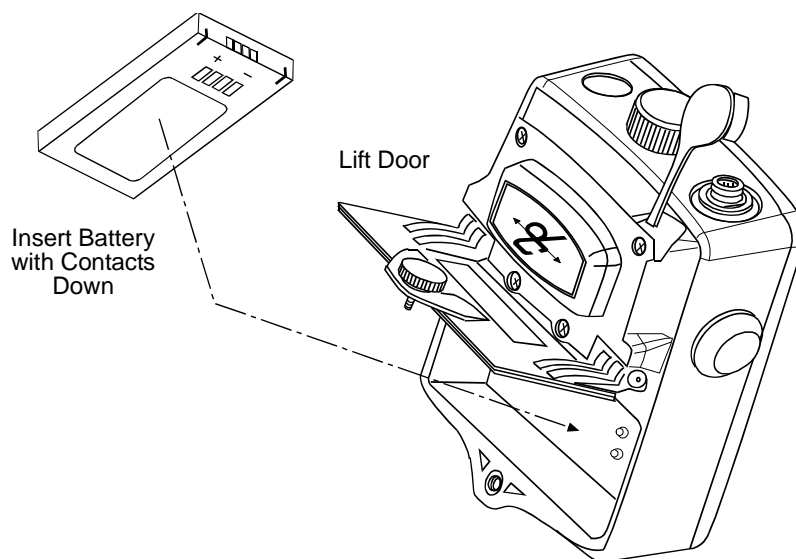

Figure 3: Battery Insertion/Removal

Troubleshooting

Table 3: Troubleshooting

Problem	Solution
Controller will not turn on	Review <i>Power-up/Power-down</i> procedure Ensure a fresh battery is installed
Cannot link a belt station	Review <i>Linking</i> procedure Ensure units are within 1 to 3ft (0.3 to 0.9m) of each other Try a <i>Full Purge</i>
No sidetone	No Belt Stations connected VOX set too high
Low receive audio	Adjust left/right volume knobs on headset
No audio /intermittent audio	Check headset connection to belt station

Replacement Parts

- Battery (P/N: 09525P-23)
- Protective skin, black (A99-01SKN, P/n 40796G-02)

Care and Maintenance

The U9911-BSC is not user serviceable. Do not attempt to open the enclosure. If this product requires service, please contact the David Clark Co., Inc Customer Service department:

- **Phone:** 800.298.6235
- **E-Mail:** serviceWWW@DavidClark.com
- **By Mail:** Customer Service
David Clark Company
360 Franklin Street
Worcester, MA 01604

If necessary, the U9911-BSC may be wiped down with a mild soap and water mixture. Although it is a sealed device designed to withstand submersion in water to 1 meter, do not unnecessarily submerge this product in water.

Avoid storage of this product in direct sunlight or high temperature environments.

Specifications

Frequency Range	1920 MHz - 1930 MHz (U.S. and Canada) 1880 MHz - 1900 MHz (EU)
Average RF Power Output	4 mW (100mW peak) (U.S. and Canada) 10 mW (250 mW peak) (EU)
Range	300 ft (100m) line-of-sight (nominal)
Battery Life	24 hrs continuous use (nominal)
Operating Temperature	-14°F to 113°F (-10°C to +45°C)
Storage Temperature	-4°F to 140°F (-20°C to +60°C)
Power Requirements	3.7V @ 100mA nominal
Battery Type	3.7V 2000mAh Li-Polymer

FCC Part 15 Statement

RADIO AND TELEVISION INTERFERENCE

This equipment has been tested and found to comply with the limits for a Class B digital device, pursuant to Part 15 of the FCC rules. These limits are designed to provide reasonable protection against harmful interference in a residential installation. This equipment generates, uses and can radiate radio frequency energy and, if not installed and used in accordance with the instructions, may cause harmful interference to radio communications. However, there is no guarantee that interference will not occur in a particular installation. If this equipment does cause harmful interference to radio or television reception, which can be determined by turning the equipment off and on, the user is encouraged to try to correct the interference by one or more of the following measures:

- Reorient or relocate the receiving antenna.
- Increase the separation between the equipment and the receiver.
- Connect the equipment into an outlet on a circuit different from that to which the receiver is connected.
- Consult the dealer or an experienced radio/TV technician for help.

You may also find helpful the following booklet, prepared by the FCC: "How to Identify and Resolve Radio-TV Interference Problems." This booklet is available from the U.S. Government Printing Office, Washington D.C. 20402.

* In order to maintain compliance with FCC regulations shielded cables must be used with this equipment. Operation with non-approved equipment or unshielded cables is likely to result in interference to radio & television reception.

Industry Canada Statement

This device complies with Industry Canada licence-exempt RSS standard(s). Operation is subject to the following two conditions: (1) this device may not cause interference, and (2) this device must accept any interference, including interference that may cause undesired operation of the device.

Unauthorized Changes

Changes or modifications not expressly approved by David Clark Company, Inc. could void the users' authority to operate the equipment.

Usage Restrictions

US Models

Due to the UPCS frequencies used, this product is licensed for operation only in the United States of America and Canada.

EU Models

Due to the DECT frequencies used, this product is licensed for operation only in the European Union countries.

SAR Statement

Radio wave exposure and Specific Absorption Rate (SAR) information

This product has been designed to comply with applicable safety requirements for exposure to radio waves. These requirements are based on scientific guidelines that include safety margins designed to assure the safety of all persons, regardless of age and health. The radio wave exposure guidelines employ a unit of measurement known as the Specific Absorption Rate, or SAR. Tests for SAR are conducted using standardized methods with the product transmitting at its highest certified power level in all used frequency bands. The product is designed to meet the relevant guidelines for exposure to radio waves.

SAR data information for residents in countries that have adopted the SAR limit recommended by the International Commission of Non-Ionizing Radiation Protection (ICNIRP), which is 0.08 W/kg averaged over ten (10) gram of tissue (for example European Union, Japan, Brazil and New Zealand): The highest SAR value for this product when tested for use on the body is 0.296 W/kg.