

FORWARD

- Please read this manual carefully before using this product and retain it properly for future reference.
- If there is any doubt or difficulty in the process of product usage, please feel free to contact us or the dealer.
- The company reserves the authority to amend the specification.

PACKING LIST



* Please take all the actual accessories as the standard.

BRIEF INTRODUCTION

FreeCast™ is designed for live video wireless monitoring for outdoor sports, outdoor video broadcasting, outdoor photography / cinematographer. It seamlessly transmits footage captured by action cameras in big range. It is a compact and portable device with industrial dust and waterproof design, weighing only 400g. FreeCast supports video browsing via iOS and Android OS devices. With good channel selection ability and video encryption, it perfectly fits video transmission requirement of outdoor applications.

FEATURES

- Special wireless video transmission device for action camera.
- Adopt High-speed wireless transmission technology, it features ultra-low latency and long transmission range. Support up to 3 smartphone clients live stream the footage simultaneously.
- Perfectly compatible with iOS / Android operating system for real-time monitoring.
- H.264 compression technology, high-quality intensive compression, State-of-art video quality.
- Supports manual channel switching.
- Dustproof and waterproof, up to IP68 (transmitter only).
- Perfect environmental adaptability, operating temperature -10~50°C.
- Compact and portable design.
- The transmitter support Mini-USB power supply.

MECHANIC INFORMATION

TX : CP07029

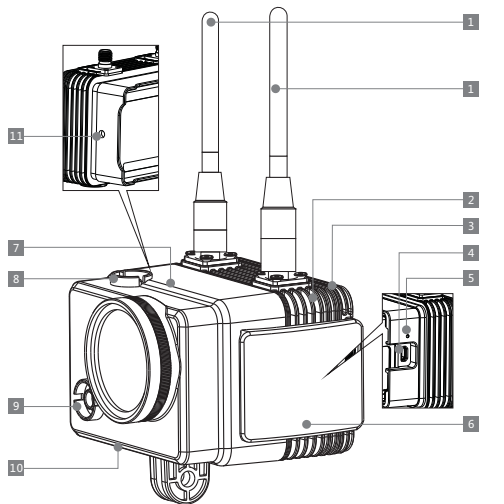

- | | | |
|-----------------------------|--------------------------------|------------------------------|
| 1 Omnidirectional Antenna | 2 Transmitter | 3 Waterproof case rear plate |
| 4 Micro HDMI in | 5 WIFI Indicator | 6 Locking buckle |
| 7 Waterproof front plate | 8 Setting Key of action camera | 9 Power Key of action camera |
| 10 Power Key of transmitter | 11 Pairing Key | |

RX : CP03029

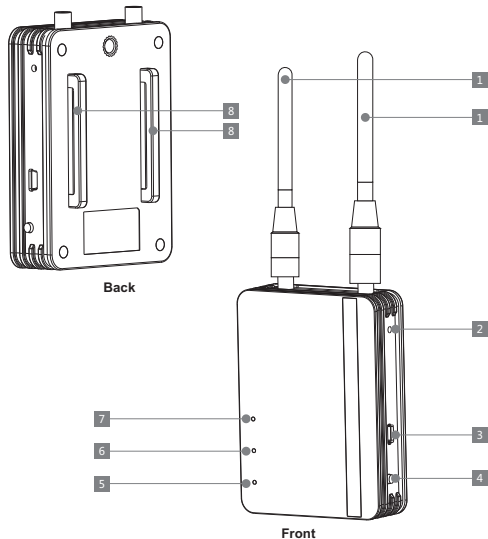

- | | | |
|---------------------------|------------------------------------|---------------------------|
| 1 Omnidirectional Antenna | 2 Channel Switching & Paring Key | 3 USB Power Supply Socket |
| 4 Power Switch | 5 Charging & low battery indicator | 6 WIFI Indicator |
| 7 Frequency Indicator | 8 Binding Belt Slot (Holder) | |

INSTALLATION

TX:CP07029 Installation

1. Mount action camera into the front part of transmitter.
Connect camera interface to transmitter HDMI socket by HDMI cable.
2. Insert lithium battery into the battery bay of transmitter.
(Special notice: ansmmitter doesn't come with lithium battery, Recommend users to buy lithium batteries.
3. Mount the antenna on the top of transmitter (as picture shows).

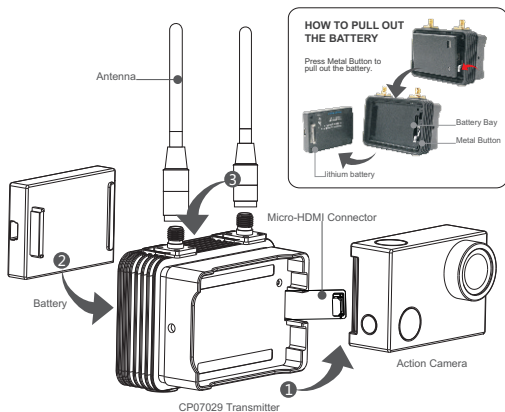

4. Cover waterproof rear plate to the rear side of transmitter.
5. Cover waterproof front plate to the front side of transmitter.

6. Lock up the left and right buckle.
7. Fix the ready transmitter to your desired place by action camera bracket.
8. Power on action camera.
9. Power on transmitter.

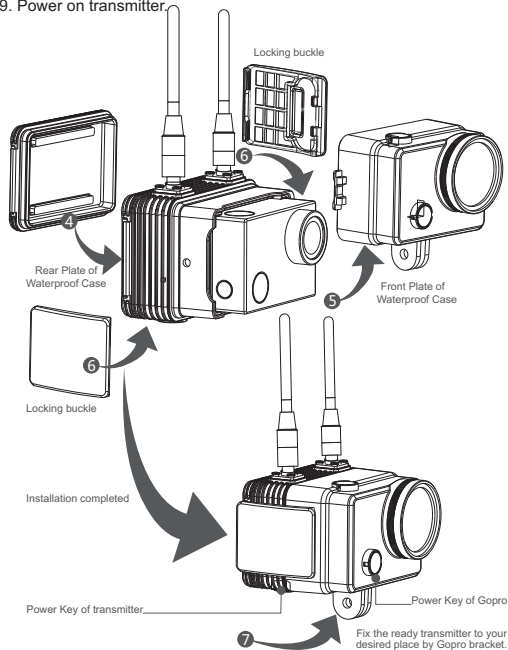

Receiver CP03029 Installation

1. Mount the antenna on the top of receiver.
2. Put the binding belt through the slot of receiver rear side. (Picture 2)
3. Fasten the receiver on arm or other desired places. (Picture 3)



2



3

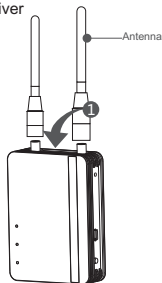

4. Search and connect tablet and Smartphone to Wifi AP of receiver (FREECAST****Password:12345678), after wifi AP connected, run corresponding App for live streaming, real-time monitoring, taking picture, recording, playback and other operations. (as illustration shows)
5. In outdoor operation, you can supply power to the receiver by USB cable.



SPECIFICATION

Transmitter : CP07029	
Item	Data
Transmission Power	6dBm
Transmission Range	Up to 300-500m
Latency	200mS
External antenna interface and impedance	RPSMA male, Impedance 50Ω
Frequency	5150~5250、 5725~5850MHz
Video Bitrate	Constant Bitrate 2Mbps
Resolution	1080P60Hz,720P60Hz
Video Encoding format	H.264 image compression
Wireless Standard	IEEE 802.11n
Operating voltage	3.3V-4.2V Lithium Battery Powered
Power Consumption	Approx 3W
Temperature	-10 °C ~ +50°C (Operating) ; -20~+75°C (Storage)
Weight	400G (including battery and antenna)
Waterproof grade	IP68
Dimensions	92mm (W) x 53mm (H) x 21.5mm (D)

Receiver : CP03029	
Frequency	5150~5250、 5725~5850MHz
receiver sensitivity	≤ -87dBm
External antenna interface and impedance	2x2 MIMO External antenna RPSMA male 50Ωantenna gain 2dBi
Wireless Standard	IEEE 802.11n
Transmission Range	Up to 300-500m
Latency	200mS
OS Requirements for Handheld device	iOS 5.0 ; Android4.0
Basic Functions	Support live streaming, taking picture, recording and playback Support up to 3 smartphone clients live stream the footage simultaneously
Power Supply	Built in 3.7V Lithium Battery
Operating Hours	Approx 7H
Power Consumption	≤1.5W
Temperature	-10 °C ~ +50°C (Operating) ; -20~+75°C (Storage)
Dimensions	90.5mm (W) x 64.5mm (H) x 21.5mm (D)

INDICATOR DESCRIPTION

Model	LED indicator	Indicator Status	Status
Transmission CP07029	WiFi indicator (BLU)	On	Connected
		Flash Slowly	Waiting for connection
		Flash Rapidly	Start WPS coding
	Low-Battery Indicator (RED)	Blinking	Low-battery
Receiver CP03029	WiFi indicator	On	Connected
		Flash Slowly	Waiting for connection
		Flash Rapidly	Start WPS coding
	Frequency indicator	Blinking	The number of blinks indicates the current frequency value
		Off	No frequency switching
	Battery Indicator	Red Indicator blinking	Low-battery
		Yellow Indicator off	Battery full
Yellow Indicator on		Charging battery	

TROUBLE SHOOTING

	Malfunction	Failure Cause	Solution
Image	No Picture	The Receiver doesn't power on	Power on the Receiver
		The Receiver doesn't connected to APP device	Connecting receiver to APP device over Wifi
		Exception connection between Signal source and transmitter	Check up interface channel between Signal source and transmitter
		Exception of transmitter	Restart the transmitter
		Exception of Receiver	Restart the Receiver
		Tx / Rx antenna are not erect	Keep Tx / Rx antenna erect
	Picture is not clear, with noise and mosaics	The distance between Tx and Rx exceed Effective transmission range	Move Receiver closer to the transmitter
		Solid walls between Tx and Rx.	Reduce the solid walls between Tx and Rx
		Too many obstacles between Tx and Rx	Move Receiver closer to the transmitter or skip the obstacles

SPECIAL NOTICE

- Although the product has provided the function of data encryption when transmitting, you still need to pay attention to deliberate signal interception. There will be the Possibility of a third party intentionally intercept the transmission signal since the product adopt wireless communication. Please do not use the product on confidential and important communications, or life-related communications. The main concern is that the content of wireless communication might be received by the third party's wireless devices deliberately or accidentally.
- The impact of radio waves (such as the following environment may cause the abnormal audio and video(blocked image, noise ...etc.).
 - Transmit near the wall which is hard for the radio waves to get through.
 - Quite close to the refrigerator, metal fitment and appliances, or next to the crowded situation.
- This product has been tested and manufactured to comply with national electrical safety rules, however, there will be noise caused by the interference with other machines in rare cases. If the interference is happened, please keep a certain distance away from other machines.
- DO NOT turn the power on before the antennas are properly installed.
- Please do not set up the transmitter and receiver in metal shelf, or it will hinder the wireless communications.
- It will take 15-20 seconds to boot the system before wireless communication start, the media receiver can not be operated during this time.

* Since the product's improving process, all the performance, design and specifications of our products are subject to minor change without prior notice.



iOS



Android

FCC Statement

Changes or modifications not expressly approved by the party responsible for compliance could void the user's authority to operate the equipment.

This equipment has been tested and found to comply with the limits for a Class B digital device, pursuant to Part 15 of the FCC Rules. These limits are designed to provide reasonable protection against harmful interference in a residential installation.

This equipment generates uses and can radiate radio frequency energy and, if not installed and used in accordance with the instructions, may cause harmful interference to radio communications. However, there is no guarantee that interference will not occur in a particular installation. If this equipment does cause harmful interference to radio or television reception, which can be determined by turning the equipment off and on, the user is encouraged to try to correct the interference by one or more of the following measures:

- Reorient or relocate the receiving antenna.
- Increase the separation between the equipment and receiver.
- Connect the equipment into an outlet on a circuit different from that to which the receiver is connected.
- Consult the dealer or an experienced radio/TV technician for help

This device complies with part 15 of the FCC rules. Operation is subject to the following two conditions (1) this device may not cause harmful interference, and (2) this device must accept any interference received, including interference that may cause undesired operation