



- Full HD Video
- SDI & HDMI
- Zero Latency
- Plug & Play
- Rugged Design

Wireless Video Link PRO 200

EU Environmental Protection

Waste electrical products should not be disposed of with household waste. Please recycle where facilities exist. Check with your local authority or retailer for recycling advice.



User Manual

Model: 7051 (Transmitter)
3051 (Receiver)



Version: 1.0

Important Information

Please read this user manual before you use this product, it contains all the notes and important things regarding operating this product. In accordance with the safety precautions and operating instructions listed on this user manual, our applies provided the product is handled properly for its intended use, but may not apply to below cases:

- Repairs or product modification and alterations have been executed by unauthorized personnel.
- The damages are caused by accidents including but not limited to lightning, fire, exposed to rain or water, and moisture.
- Do not use provided power adapter with specific power voltage which are not compliant with the rated voltage range in the attached label of the power adapter in package.
- The model label on the product has been modified or the warranty tag has been removed by unauthorized personnel.

Safety Precaution

 Danger! High voltage	To reduce the risks of electricity, do not remove or open the cover. No user-serviceable parts are inside. Please return to original factory for maintenance
 Beware of hot surfaces!	The high temperature in the process of operating the device may cause the high risk of scalding.
 Caution!	Please use our standard power adapter. Detailed information Please refer to the rated voltage range showed on the label at the back of package's power adapter.

Danger: Be careful with electricity.

- As connecting any equipment (such as any player or TV , etc.), please turn off the power to the product before any operation is undertaken.
- Power outlet: To prevent electric shock or fire, short circuit, please make sure the type of electrical plug used on the receiver's and transmitter's power cord are compliant with the rated voltage range in the attached label of the power adapter in package.
- Power cord: Do not place any heavy articles above on the power cord. To avoid being stepped on or pinched by heavy items, the power cord should not be located on the place where people pass by frequently.
- Power overloading: Avoid overloading wall's electrical outlets and extension cord or other multi-socket; otherwise could result in electric shock or fire.
- Lightning: For protection from lightning or when the product is left unattended for a long period, please disconnect it from the power source.
- Please disconnect the power cord from the power outlet when you are not using the receiver and transmitter, this will reduce the risk of electric shock or fire.

Warning

- This product should not be exposed to dripping or splashing. Do not place any object filled with liquid on the product (eg. vases).
- To avoid electric shock, please do not block or stick anything on the air vent of product; do not remove the cover or put the object just like pins, steel wire into the gap of the air vent.
- Please place the receiver/ transmitter on a flat with hard and stable surface.
- Ventilation: please do not block the air vents on the receiver/transmitter or place any heavy object on top of them . Blocking the air flow can damage the product itself. Please make sure that there is adequate ventilation distance between the receiver and TV, and also put the product away from direct sunlight or any source of heat.
- Water Exposure: To reduce the risk of electric shock or fire , please do not expose the receiver/transmitter to rain or moisture.
- We assume no responsibility for any damage or result caused by using other adapters instead of our standard adapters

Special Notice

- Although the product has provided the function of data encryption when transmitting, you still need to pay attention to deliberate signal interception. There will be the Possibility of a third party intentionally intercept the transmission signal since the product adopt wireless communication. Please do not use the product on confidential and important communications, or life-related communications The main concern is that the content of wireless communication might be received by the third party's wireless devices deliberately or accidentally.
- The impact of radio waves (such as the following environment may cause the abnormal audio and video (blocked image, noise ...etc.).
 - 1) Transmit near the wall which is hard for the radio waves to get through.
 - 2) Quite close to the refrigerator, metal fitment and appliances, or next to the crowded situation.
- This product has been tested and manufactured to comply with national electrical safety rules, however, there will be noise caused by the interference with other machines in rare cases. If the interference is happened, please keep a certain distance away from other machines.
- The product is susceptible to interference from 5GHz wireless local area network or other wireless devices.
- Optimal range between transmitter and receiver is between 1 meter and 50 meters within line of sight indoor.
- Please do not set up the transmitter and receiver in metal shelf, or it will hinder the wireless communications.
- 1080P/60 Hz Wireless transmitting.
- It will take 15-20 seconds to boot the system before wireless communication start, the media receiver can not be operated during this time.

Contents

About this manual	02
Brief introduction	02
Features	02
Packing list	03
Specification	04
Mechanical information	05
Wireless HD Transmitter:7051	05
Wireless HD Receiver:3051	07
Product Installation	09
Wireless HD Transmitter:7051	09
Wireless HD Receiver:3051	11
LED Digits Display description	13
Transmission Distance Description	15
Trouble shooting	18

Foreword

- Please read this manual carefully before you use this product and retain it properly for future reference.
- If there is any question or difficulty about the operation of product, please feel free to contact us or the dealer.
- CVW reserves the authority to modify the instruction manuals.

Brief Introduction

As the widely use of live broadcasting , many problems about wiring appear, such as the high cost and short life time of the cable. Further, some other factors affect the user experience of live broadcast, such as the insufficient cable protection and the tread bycrowded people, which will lead to the poor cable transmission capability or even to accident. PRO200 provides you more convenient and safer solution for live broadcasting. With the advantage of long distance transmission, plug-and-play usage, it can satisfy your various indoor and out door shooting requirements. With addition of its free cable wiring needed,it will bring much safer and more professional experience to you!

Features

- The product with its transmission distance of up to 200 meters can meet the demands of film shooting, television broadcasting, live events, large conference, etc.
- The product delivers uncompressed real-time 1080P/60Hz full HD video (4:2:2, 10bit).
- Support HDMI, HD-SDI, 3G-SDI.
- Full hardware design, plug & play;
- Support manual setting for channel switching and broadcast mode.
- Support SDI time code transmission (time code format: ATC_VITC, ATC_LTC).
- Support SDI camera recording trigger function (Start/Stop Flag) transmission.
- Comply with EDID Structure 1.1 and support HDMI 1.3.
- Support AES128/256 bit image encryption.

Packing List

Please check the package inside to assure it contains the parts as below, if any parts missed, please contact the distributor or us.



* Some of the accessories are optional with extra cost, if you need to purchase, please contact the distributor or us.

* If some changes on the appearance, logo and accessories, subject to the actual received product.

Specification

Item	Specification
Frequency	Image transmission :5.15~5.25GHz(for FCC) and 5.725~5.85GHz (for FCC&IC)
Bandwidth	40MHz
Video Formats	1080P 23.98/24/25/30/50/60 1080psf 23.98/24/25 1080i 50/59.94/60 720P 50/59.94/60 576P 576i 480p 480i
Audio Formats	PCM
Time Code	ATC_VITC ATC_LTC
Transmission distance	Up to 200m
Transmitter	
Antenna	External antenna * 2
Interface	HDMI input,SDI input, Mini-USB,Lemo(0B/2pin) DC in, Antenna RPSMA, Power switch
Mechanical Interface	V-mount, 1/4" fixing screw hole
LED Digits Display	Display the working channel
Working Voltage	DC 7V ~ 36 V
Power Consumption	7W
Temperature	-10~50°C(Working) ; -40~80°C(Storage)
Receiver	
Antenna	External antenna * 5
Receiver Sensitivity	-70dBm
Interface	HDMI output, SDI output, Mini-USB,Lemo(0B/2pin) DC in, Antenna RPSMA,Power switch
Mechanical Interface	V-mount, 1/4" fixing screw hole
LED Digits Display	Display the working channel
Working Voltage	DC 7V ~ 36 V
Power Consumption	5~6W
Temperature	-10~50°C(Working) ; -40~80°C(Storage)

* As the product's continuous improvement, the performance, design and specifications are subject to minus change without prior notice.

Mechanical Information

TX

Transmitter Interface

Model : 7051

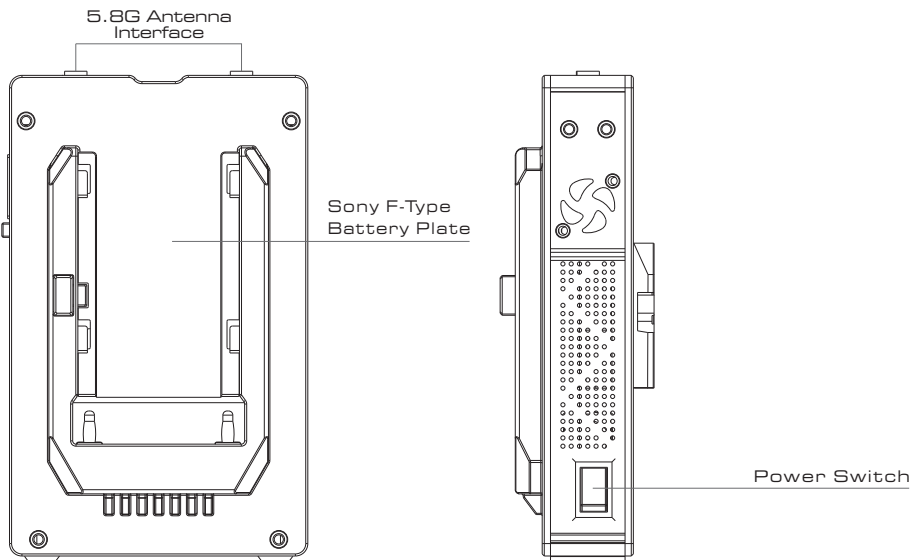
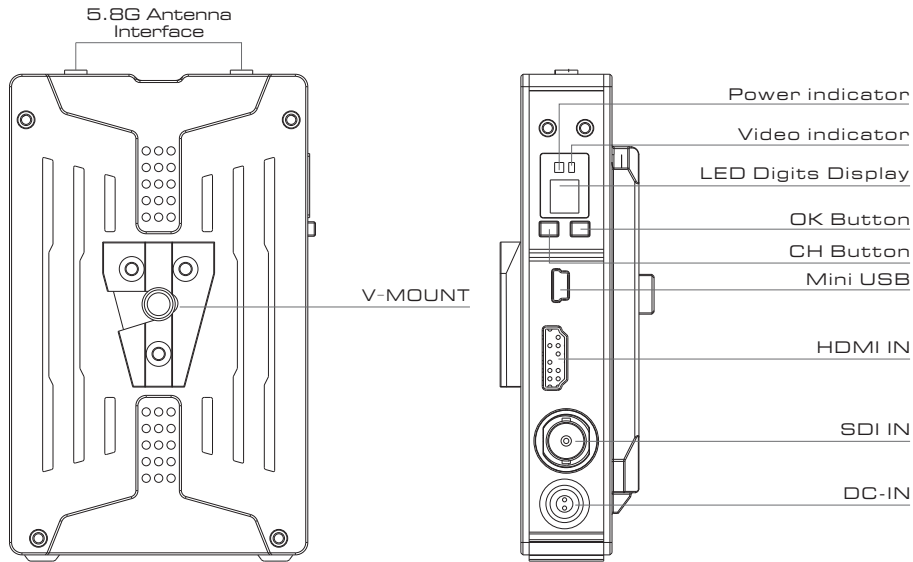

Transmitter Interface Description

Item	Specification
LED Digits Display	Display the working channel
OK Button	Confirm the function selection
CH Button	Switch the working channel
Mini USB	Be used for software upgrading
HDMI IN	HDMI IN
SDI IN	SDI IN
DC-IN	Power input interface (LEMO): support 7V to 36V (Notice: please confirm the polarity before you plugging in the power supply.)
5.8G Antenna Connector	Connect with RP-SMA antenna
V-MOUNT	Support installation of V-mount devices
Sony F-Type Battery Plate	Be used for installing external Sony F-type battery
Power Switch	Power ON/OFF

Receiver Interface

Model : 3051

RX

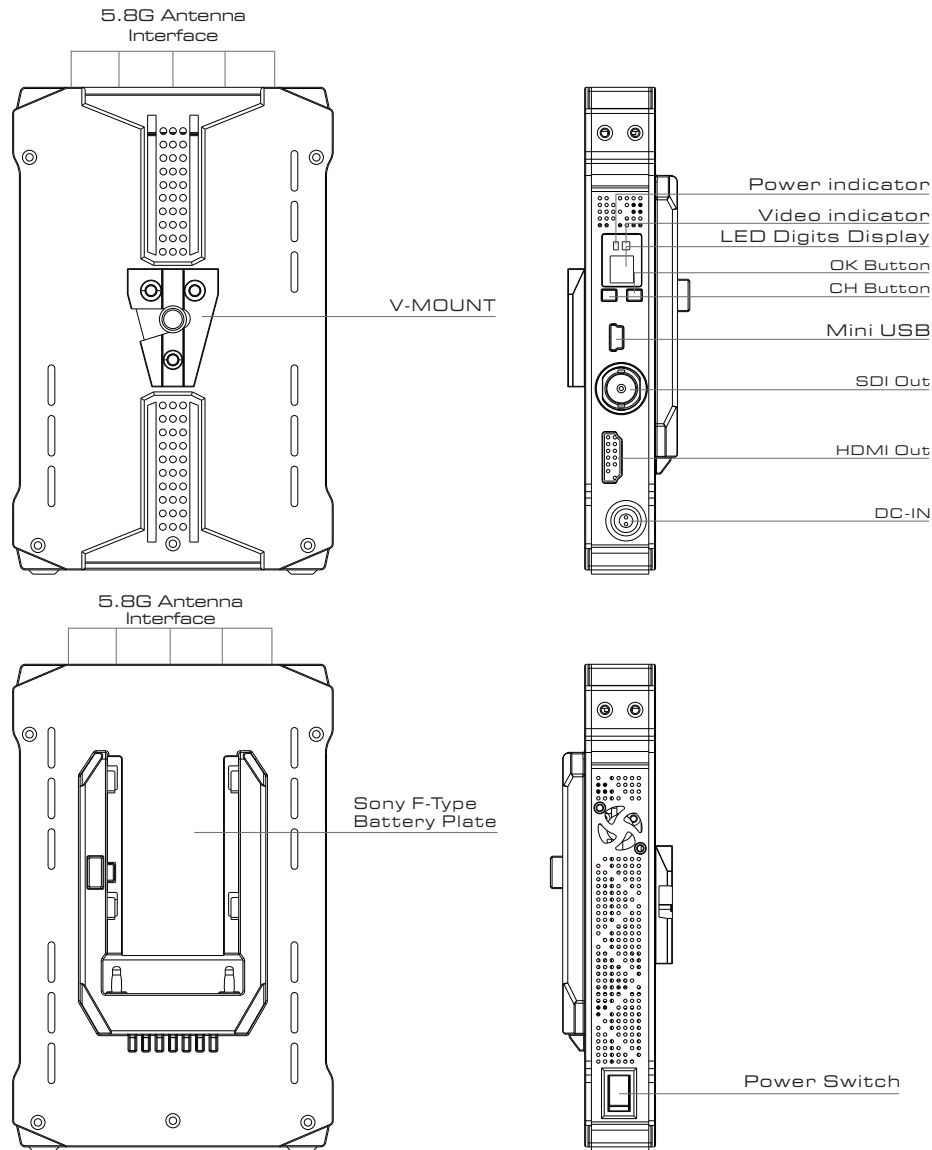

Receiver Interface Description

Item	Specification
LED Digits Display	Display the working channel
OK Button	Confirm the function selection
CH Button	Switch the working channel
Mini USB	Be used for software upgrading
HDMI OUT	HDMI OUT
SDI OUT	SDI OUT
DC-IN	Power input interface (LEMO): support 7V to 36V (Notice: please confirm the polarity before you plugging in the power supply.)
5.8G Antenna Connector	Connect with RP-SMA antenna
V-MOUNT	Support installation of V-mount devices
Sony F-Type Battery Plate	Be used for installing external Sony F-type battery
Power Switch	Power ON/OFF

Product Installation

TX

Transmitter Installation Steps:

1. Fix the antennas and adjust their angles as shown in the figure below.
(For details, see the Transmission Distance Description.)

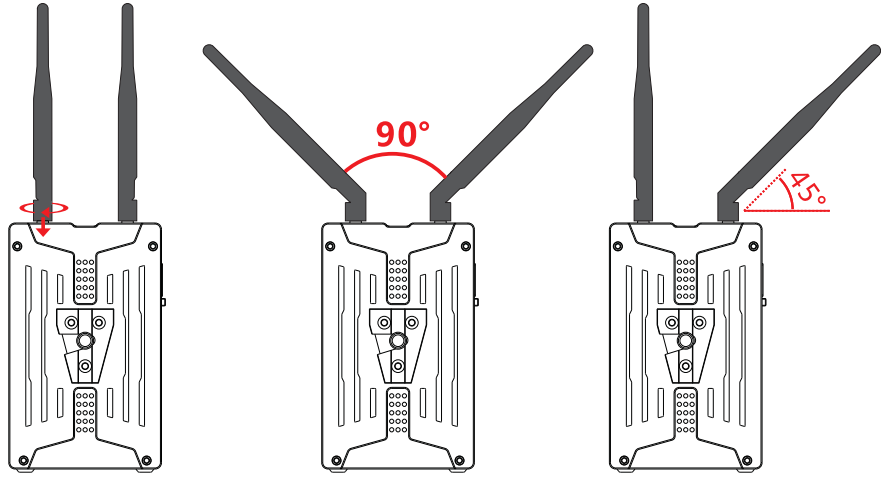

Notice: please rotate the golden mental part of antenna to fasten the antenna.

Antenna Pattern 1: 90° angle in the same plane

Antenna Pattern 2: Right side 45° angle rotation towards backside

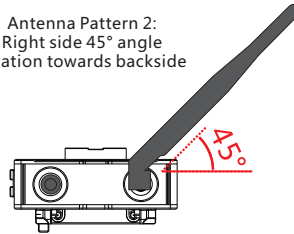

2. Connect Tx with the camera via corresponding power cable and HD video cables as shown in the figure below.

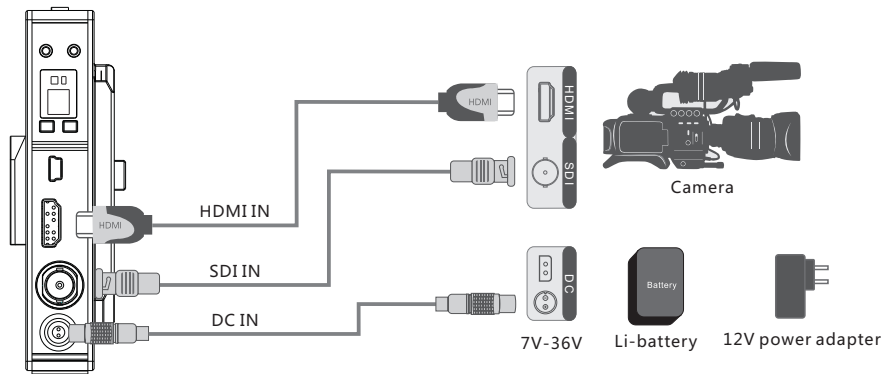

3. Turn on the power switch to start power supplying.

Power Switch: ON turn on
OFF turn off

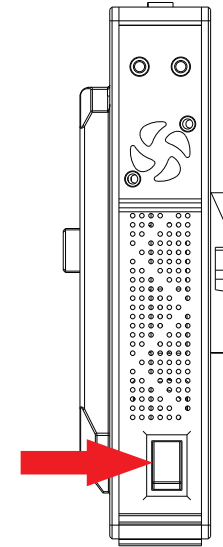

4. Press "CH" button to select the corresponding working channel of receiver and then press "OK" button for confirmation. The LED digits display will display one of the characters from 1 ~ 9, A and b when the video signal of device is normal.

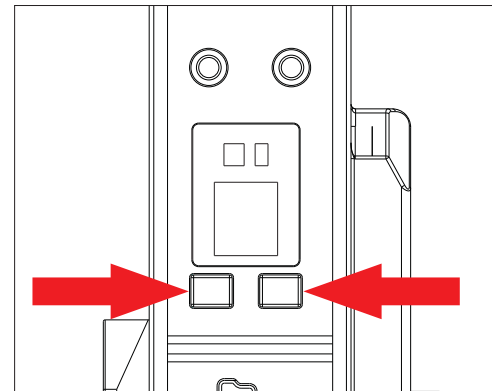

5. The transmitter supports manually switching the SDI audio input mode by long pressing "OK" button. (Notice: This function is only valid for SDI audio input and won't affect the HDMI audio input.) The default value of SDI audio input mode is 0 and the decimal point will be set to be non-bright under this mode; long press "OK" key button for more than 3 seconds, and then the LED digits display will display SDI audio input mode as 1 while the decimal point will be bright.

Receiver Installation Steps:

RX

1. Fix the antennas and adjust their angles as shown in the figure below.

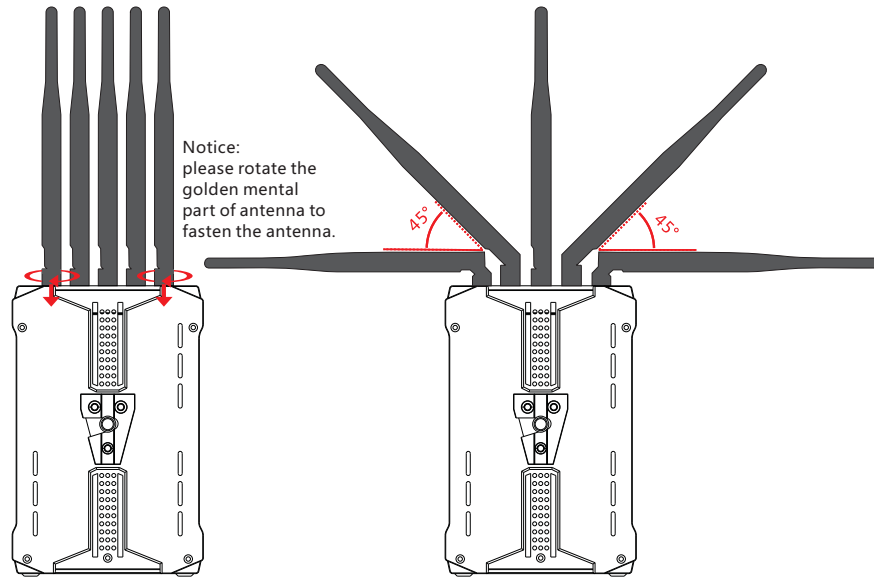

2. Connect RX with the monitor via corresponding power cable and HD video cables as shown in the figure below.

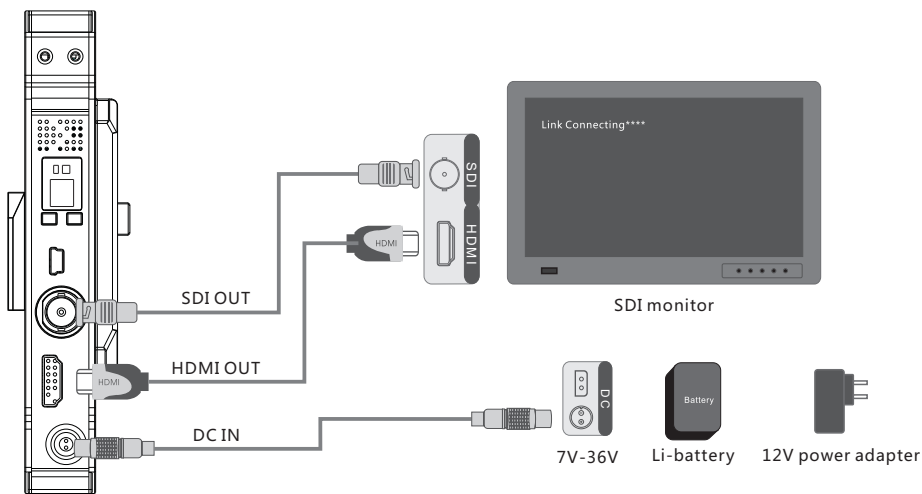

3. Turn on the power switch to start power supplying.

Power Switch: ON turn on
OFF turn off

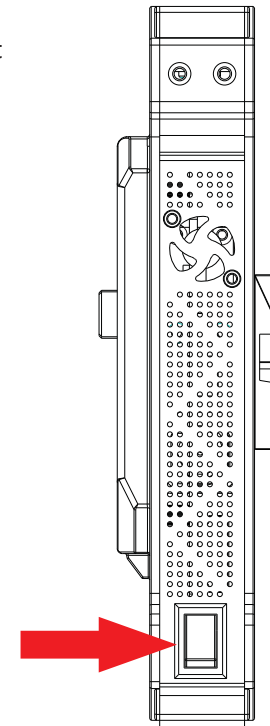

4. Press "CH" button to select the corresponding working channel of receiver and then press "OK" button for confirmation. The LED digits display will display one of the characters from 1 ~ 9, A and b when the video signal of device is normal; the monitor will display the image from camera simultaneously.

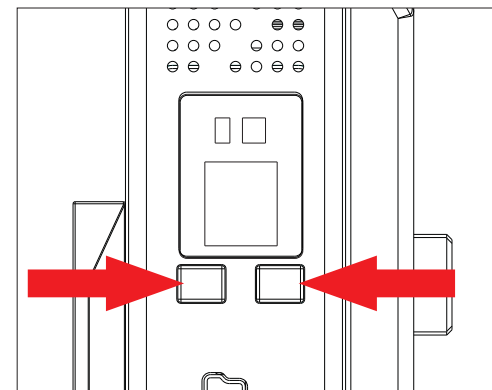

LED Digits Display description

LED Digits Display Status

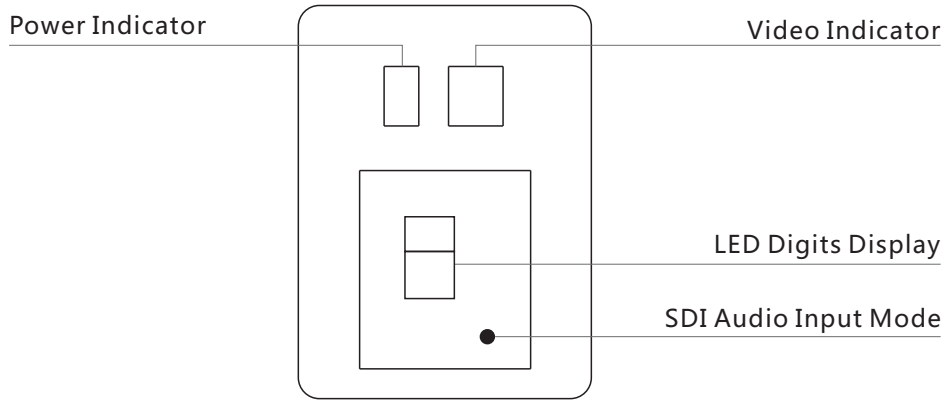

Transmitter

LED Digits Display: Channel 1 ~ 4

Video Indicator: Red: HDMI input; Yellow: SDI input

Power Indicator: Illuminate in working mode

SDI Audio Input Mode:

Decimal point light is off: SDI Audio Input Mode 0

Decimal point light is on: SDI Audio Input Mode 1

Receiver

LED Digits Display: Channel 1 ~ 4

Video Indicator: Red: HDMI input;
Yellow: SDI input(Default: HDMI and SDI outputs are both enabled by default.)

Power Indicator: Flash slowly when the network is not connected.
Light on normally when the network is connected.

Support Full PSF resolution

Support Full PSF resolution

25PFS in = 25PFS out	23.98P in=23.98P out
29.97PSF=29.97PSF out	24P in=24P out
30PSF in = 30PSF out	25P in=25P out
	29.97P in=29.97P out
	30P in=30P out
50i in = 50i out	
59.94i in = 59.94i out	
60i in = 60i out	

Transmission Distance Description

Transmission Distance

Provided that the product is working under the condition of line of sight distance by adopting the optimal installation:

1. Make sure that the fixed angle between transmitter antennas is 90° in the same plane, and enable the face-to-face transmission between transmitter and receiver. Under such condition, the transmission distance is up to 300 meters.
2. Rotate the right side of the 2 transmitter antennas towards backside by 45° as refer to the Antenna Pattern 2 as mentioned above. Under such condition, the transmission distance is around 200 meters when the transmitter is revolving during the shooting process.
3. If you require the transmission distance over 300 meters, please adopt the plate antennas which are available from us for transmitter. Under such condition, the transmission distance is over 1000 meters.

Optimal Distance

Make receiver to stand vertically; adjust antennas to a fan-shaped arrangement;
Make transmitter to stand vertically; adjust antennas to 90° angle in the same plane;
The distance of face-to-face transmission between TX and RX will be up to 300 meters (line of sight).

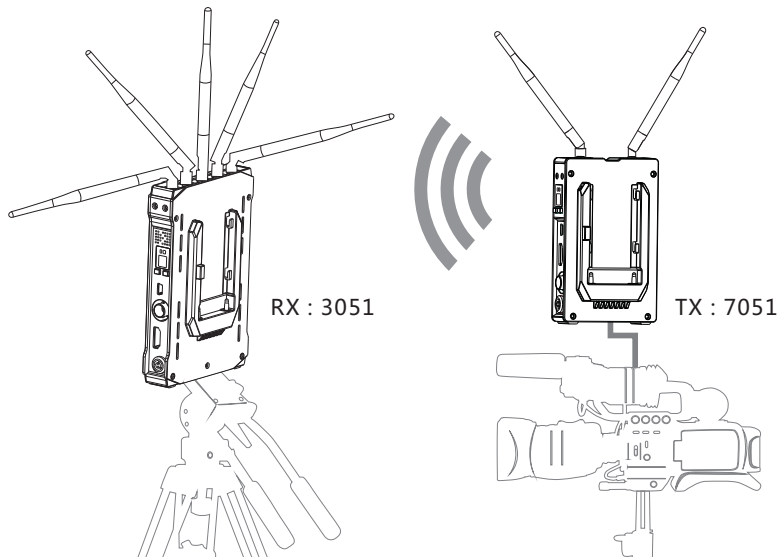

Standard Distance

Make receiver to stand vertically; adjust antennas to a fan-shaped arrangement;
Make transmitter to stand vertically; adjust the right side of the 2 transmitter antennas towards backside by 45°;

The distance of non-face-to-face transmission between TX and RX will be up to 200 meters (line of sight).

Antenna Pattern 2:
Right side 45° angle
rotation towards backside

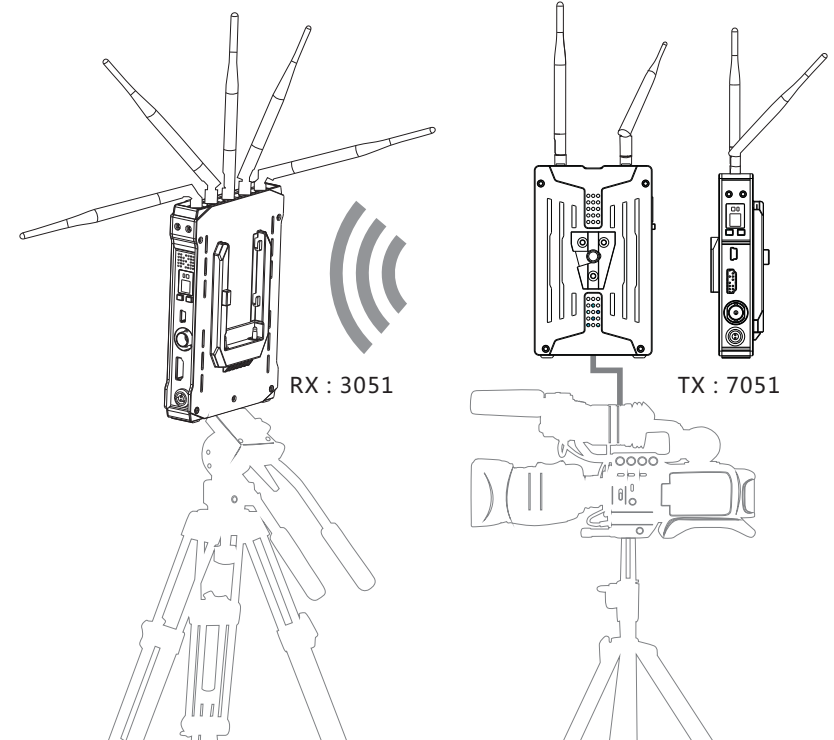

When the front side of the transmitter is not able to face to the receiver, please try to adjust the direction of transmitter antennas to make sure that the formative fan-shaped arrangement can face to the receiver for best signal transmission. As shown in the right figure:

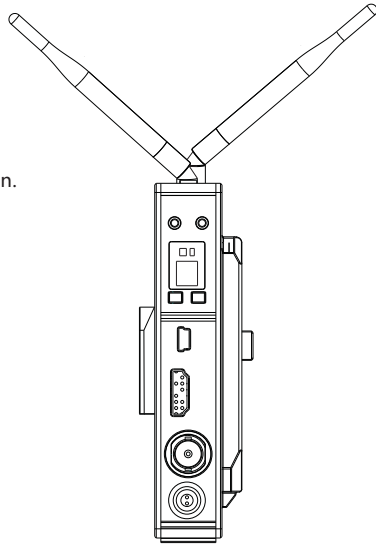

★ Notice: the channel 1 is not recommended in the long distance transmission due to its limited performance.

Trouble shooting

	Troubles & Possible Reasons:	Solutions:
OSD Information on TV	Display "Link Connecting"	
	Transmitter is not electrified.	Power on transmitter.
	Transmitter or receiver is not placed erectly.	Place the TX or RX onto the base and replace them erectly.
	The transmitter and receiver are too far away.	Move the receiver closer to the transmitter.
	Several solid wall partition TX and RX.	Reduce the number of solid walls between TX and RX.
	There are too many obstacles between TX and RX.	Move the receiver closer to the transmitter.
	Haven't matched the code of TX and RX.	Rematch the code of transmitter and receiver.
	There is other transmitter which is under working condition near the receiver.	Power off other independent transmitter, place the receiver away from the other sources of interference.
	No Video Signal received	
	Transmitter and video source are not connected.	Connect the transmitter to video source by SDI/HDMI cable.
	The video source is turned OFF.	Power ON the video source.
	Video source were NOT switched to SDI/HDMI output.	Switch the Video source to SDI/HDMI output.
	Bad contact of cable of transmitter	Remove and then re-plug the cable of transmitter
	Abnormal working of transmitter	Reboot the transmitter.
	Problem with cable between TX and video source	Change the SDI/HDMI cable.
Player NOT support the output resolution format.	Switch the output video resolution to other modes.	
The TV/Monitor NOT support HDCP authentication.	Replaced with HDCP-certified TV/Monitor.	
Image	No signal input to Receiver or TV/Monitor	
	Receiver is turned OFF.	Power on receiver.
	Receiver and TV are not connected.	Connect receiver to TV/Monitor via SDI/HDMI cable.
	TV/Monitor NOT switched to SDI/HDMI input.	Switch TV/Monitor to SDI/HDMI input.
	Bad contact of the cable of receiver or TV/monitor	Remove then re-plug the SDI/HDMI cable.
	TV/Monitor turn into standby mode	Switch the TV/Monitor to normal operation mode.
	Abnormal working of receiver.	Reboot the receiver.
	No image appear on TV/Monitor	
	Bad contact of receiver or cable.	Re-plug the cable of the receiver or TV/Monitor
	Abnormal working of receiver	Reboot the receiver
Receiver failure	Please contact your retailer	

Troubles & Possible Reasons:		Solutions:
Image	Abnormal color on TV screen	
	Bad contact of cable of receiver or TV/monitor.	Unplug and then plug the HDMI cable of the receiver or TV.
	Bad contact of cable of transmitter or video source.	Unplug and then plug the HDMI cable of the TX and player.
	Abnormal working of transmitter or receiver	Reboot the transmitter and receiver.
Audio	Image displayed, No audio	
	Video source mute	Turn on the audio of video source
	Volume too low	Turn up the audio of video source
	Audio format not supported	Switch the format of video source output
	Something wrong with transmitter/ receiver	Restart the transmission kit

*For more questions, please contact the distributor or us.

FCC Statement

This equipment complies Part 15 of the FCC Rules. Operation is subject to following two conditions:

- 1) This device may not cause harmful interference, and
- 2) This device must accept any interference received, including interference that may cause undesired operation.

This equipment has been tested and found to comply with the limits for a Class B digital device, pursuant to part 15 of the FCC rules. These limits are designed to provide reasonable protection against harmful interference in a residential installation. This equipment generates, uses and can radiate radio frequency energy and, if not installed and used in accordance with the instructions, may cause harmful interference to radio communications. However, there is no guarantee that interference will not occur in a particular installation. If this equipment does cause harmful interference to radio or television reception, which can be determined by turning the equipment off and on, the user is encouraged to try to correct the interference by one or more of the following measures:-Reorient or relocate the receiving antenna. Increase the separation between the equipment and receiver. Connect the equipment into an outlet on a circuit different from that to which the receiver is connected. Consult the dealer or an experienced radio/TV technician for help. To assure continued compliance, any changes or modifications not expressly approved by the party responsible for compliance could void the user's authority to operate this equipment. (Example use only shielded interface cables when connecting to computer or peripheral devices).

FCC Radiation Exposure Statement

This equipment complies with FCC radiation exposure limits set forth for an uncontrolled environment. This transmitter must not be co-located or operating in conjunction with any other antenna or transmitter. This equipment should be installed and operated with minimum distance 20cm between the radiator & you body.

Cautions!

The manufacturer is not responsible for any radio or TV interference caused by unauthorized modifications to this equipment. Such modifications could void the user authority to operate the equipment.

RSS warning

This device complies with ISEDC licence-exempt RSS standard (s). Operation is subject to the following two conditions: (1) this device may not cause interference, and (2) this device must accept any interference, including interference that may cause undesired operation of the device.

Le présent appareil est conforme aux CNR d'ISEDC licables aux appareils radio exempts de licence.

L'exploitation est autorisée aux deux conditions suivantes:

- (1) l'appareil ne doit pas produire de brouillage, et
- (2) l'utilisateur de l'appareil doit accepter tout brouillage radioélectrique subi, même si le brouillage est susceptible d'en compromettre le fonctionnement.

ISEDC Radiation Exposure Statement:

This equipment complies with ISEDC RF radiation exposure limits set forth for an uncontrolled environment. This transmitter must not be co-located or operating in conjunction with any other antenna or transmitter.

This equipment should be installed and operated with minimum distance 20cm between the radiator & your body.

Cet appareil est

Conforme aux limites d'exposition de rayonnement RF ISEDC établies pour un environnement non contrôlé.

Cet émetteur ne doit pas être co-implanté ou fonctionner en conjonction avec toute autre antenne ou transmetteur.

Cet équipement doit être installé et utilisé avec une distance minimale de 20cm entre le radiateur & votre corps.