



# FCC RADIO TEST REPORT

## FCC ID: Y36FD4003-D

**Product :** Receiver

**Trade Name :** N/A

**Model Number :** FD4003

### **Prepared for**

China Etech Groups Ltd.

4th Floor, A3 Building, Huafeng centery Industrial park, Xixiang town,  
Bao'an district, Shenzhen City, China

### **Prepared by**

Shenzhen NTEK Testing Technology Co., Ltd.

1/F, Building E, Fenda Science Park, Sanwei Community, Xixiang Street,  
Bao'an District, Shenzhen P.R. China

Tel.: +86-0755-61156588 Fax.: +86-0755-61156599

Website: [www.ntek.org.cn](http://www.ntek.org.cn)

## TEST RESULT CERTIFICATION

**Applicant's name** ..... : China Etech Groups Ltd.  
Address ..... : 4th Floor, A3 Building, Huafeng centery Industrial park, Xixiang town, Bao'an district, Shenzhen City, China  
**Manufacturer's Name** ..... : China Etech Groups Ltd.  
Address ..... : 4th Floor, A3 Building, Huafeng centery Industrial park, Xixiang town, Bao'an district, Shenzhen City, China

### Product description

Product name..... : Receiver  
Model and/or type reference : FD4003  
Standards ..... : FCC Part15B:2012  
ANSI C63.4:2003

This device described above has been tested by NTEK, and the test results show that the equipment under test (EUT) is in compliance with Part 15 of FCC Rules. And it is applicable only to the tested sample identified in the report.

This report shall not be reproduced except in full, without the written approval of NTEK, this document may be altered or revised by NTEK, personal only, and shall be noted in the revision of the document.

**Date of Test** ..... :  
Date (s) of performance of tests..... : 20 Dec. 2012 ~24 Dec. 2012  
Date of Issue..... : 25 Dec. 2012  
Test Result..... : **Pass**

Testing Engineer : Apple Huang  
(Apple Huang)

Technical Manager : Jim He  
(Jim He)

Authorized Signatory : Bovey Yang  
(Bovey Yang)

<b>Table of Contents</b>	<b>Page</b>
1 . TEST SUMMARY	4
1.1 TEST FACILITY	5
1.2 MEASUREMENT UNCERTAINTY	5
2 . GENERAL INFORMATION	6
2.1 GENERAL DESCRIPTION OF EUT	6
2.2 DESCRIPTION OF TEST MODES	7
2.3 DESCRIPTION OF TEST SETUP	8
2.4 DESCRIPTION TEST PERIPHERAL AND EUT PERIPHERAL	9
2.5 MEASUREMENT INSTRUMENTS LIST	10
3 . EMC EMISSION TEST	11
3.1 CONDUCTED EMISSION MEASUREMENT	11
3.1.1 POWER LINE CONDUCTED EMISSION	11
3.1.2 TEST PROCEDURE	12
3.1.3 TEST SETUP	12
3.1.4 EUT OPERATING CONDITIONS	12
3.1.5 TEST RESULTS	13
3.2 RADIATED EMISSION MEASUREMENT	15
3.2.1 LIMITS OF RADIATED EMISSION MEASUREMENT	15
3.2.2 TEST PROCEDURE	15
3.2.3 TEST SETUP	16
3.2.4 EUT OPERATING CONDITIONS	16
3.2.5 TEST RESULTS	18
3.2.6 TEST RESULTS(Above 1GHz)	20
4 . EUT TEST PHOTO	21
ATTACHMENT PHOTOGRAPHS OF EUT	24

## 1. TEST SUMMARY

Test procedures according to the technical standards:

EMC Emission				
Standard	Test Item	Limit	Judgment	Remark
FCC Part15B:2012 ANSI C63.4: 2003	Conducted Emission	Class B	PASS	
	Radiated Emission	Class B	PASS	

**NOTE:**

(1) 'N/A' denotes test is not applicable in this Test Report

1.1 TEST FACILITY

NTEK Testing Technology Co., Ltd

Add. : 1/F, Building E, Fenda Science Park, Sanwei Community, Xixiang Street, Bao'an District, Shenzhen P.R. China.

FCC Registration No.:238937; IC Registration No.:9270A-1

CNAS Registration No.:L5516

1.2 MEASUREMENT UNCERTAINTY

The reported uncertainty of measurement  $y \pm U$ , where expanded uncertainty  $U$  is based on a standard uncertainty multiplied by a coverage factor of  $k=2$ , providing a level of confidence of approximately 95 %.

A. Conducted Measurement :

Test Site	Method	Measurement Frequency Range	U , (dB)	NOTE
NTEKC01	ANSI	150 KHz ~ 30MHz	3.2	

B. Radiated Measurement :

Test Site	Method	Measurement Frequency Range	U , (dB)	NOTE
NTEKA01	ANSI	30MHz ~ 1000MHz	4.7	
		1GHz ~6GHz	5.0	

## 2. GENERAL INFORMATION

### 2.1 GENERAL DESCRIPTION OF EUT

Equipment	Receiver	
Model Name	FD4003	
Serial No	N/A	
Model Difference	N/A	
Product Description	The EUT is a Receiver.	
	Operating frequency:	N/A
	Connecting I/O port:	USB
	Based on the application, features, or specification exhibited in User's Manual, the EUT is considered as an ITE/Computing Device. More details of EUT technical specification, please refer to the User's Manual.	
Power Source	DC Voltage	
Power Rating	DC 5V from PC 120V/60Hz	

## 2.2 DESCRIPTION OF TEST MODES

To investigate the maximum EMI emission characteristics generated from EUT, the test system was pre-scanning tested based on the consideration of following EUT operation mode or test configuration mode which possibly have effect on EMI emission level. Each of these EUT operation mode(s) or test configuration mode(s) mentioned above was evaluated respectively.

Pretest Mode	Description
Mode 1	Running

For Conducted Test	
Final Test Mode	Description
Mode 1	Running

For Radiated Test	
Final Test Mode	Description
Mode 1	Running

### 2.3 DESCRIPTION OF TEST SETUP

Mode 1:

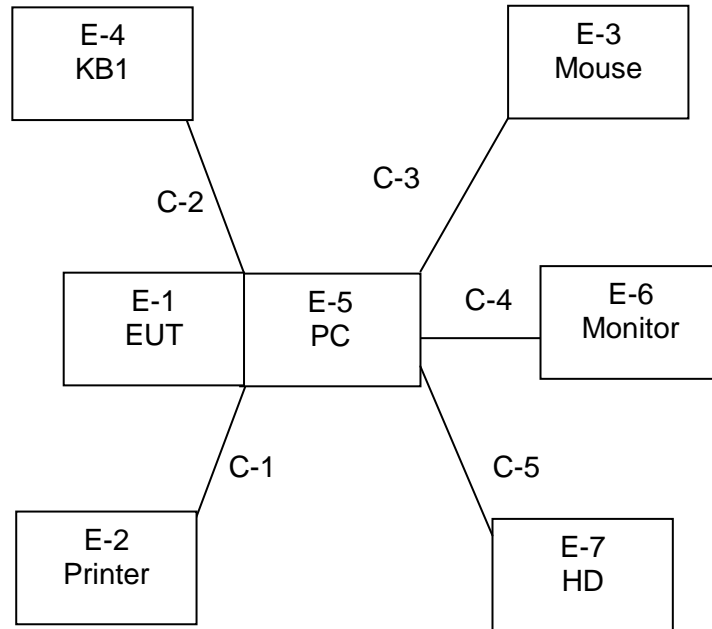



2.4 DESCRIPTION TEST PERIPHERAL AND EUT PERIPHERAL

The EUT has been tested as an independent unit together with other necessary accessories or support units. The following support units or accessories were used to form a representative test configuration during the tests.

Item	Equipment	Mfr/Brand	Model/Type No.	Series No.	Note
E-1	Receiver	N/A	FD4003	N/A	EUT
E-2	Printer	Canon	L11121E	LBP2900	
E-3	Mouse	DELL	MS111-P	cn-011d3v-71581-11e-1th7	
E-4	Keyboard	DELL	SK-8185	OY526KUS	
E-5	PC	DELL	FT4Y23X	34413561645	
E-6	Monitor	DELL	IN2020MB	cn-0y6mhx-74261-11f-67es	
E-7	HD	Buffalo inc.	HD-PET320U2	55571500924085	

Item	Shielded Type	Ferrite Core	Length	Note
C-1	NO	NO	120cm	
C-2	NO	NO	180cm	
C-3	NO	NO	180cm	
C-4	NO	NO	150cm	
C-5	NO	NO	50cm	

Note:

- (1) The support equipment was authorized by Declaration of Confirmation.
- (2) For detachable type I/O cable should be specified the length in cm in 『Length』 column.
- (3) “YES” means “shielded” “with core”; “NO” means “unshielded” “without core”.

## 2.5 MEASUREMENT INSTRUMENTS LIST

### 2.5.1 CONDUCTED TEST SITE

Item	Kind of Equipment	Manufacturer	Type No.	Serial No.	Calibrated until
1	LISN	R&S	ENV216	101313	Jul. 06, 2013
2	LISN	EMCO	3816/2	00042990	Jul. 06, 2013
3	50Ω Switch	ANRITSU CORP	MP59B	6200983704	Jul. 06, 2013
4	Test Cable	N/A	C01	N/A	Jul. 06, 2013
5	Test Cable	N/A	C02	N/A	Jul. 06, 2013
6	Test Cable	N/A	C03	N/A	Jul. 06, 2013
7	EMI Test Receiver	R&S	ESCI	101160	Jul. 06, 2013
8	Passive Voltage Probe	ESH2-Z3	R&S	100196	Jul. 06, 2013
9	Triple-Loop Antenna	EVERFINE	LIA-2	11020003	Jul. 06, 2013
10	Absorbing Clamp	R&S	MDS-21	100423	Jul. 08, 2013

### 2.5.2 RADIATED TEST SITE

Item	Kind of Equipment	Manufacturer	Type No.	Serial No.	Calibrated until
1	Bilog Antenna	TESEQ	CBL6111D	31216	Jul. 06, 2013
2	Test Cable	N/A	R-01	N/A	Jul. 06, 2013
3	Test Cable	N/A	R-02	N/A	Jul. 06, 2013
4	EMI Test Receiver	R&S	ESCI-7	101318	Jul. 06, 2013
5	Antenna Mast	EM	SC100_1	N/A	N/A
6	Turn Table	EM	SC100	060531	N/A
7	50Ω Switch	Anritsu Corp	MP59B	6200983705	Jul. 06, 2013
8	Spectrum Analyzer	Agilent	E4407B	MY45108040	Jul. 06. 2013
9	Horn Antenna	EM	EM-AH-1018 0	2011071402	Jul. 06. 2013
10	Amplifier	EM	EM-30180	060538	Jul. 06. 2013

### 3. EMC EMISSION TEST

#### 3.1 CONDUCTED EMISSION MEASUREMENT

##### 3.1.1 POWER LINE CONDUCTED EMISSION (Frequency Range 150KHz-30MHz)

FREQUENCY (MHz)	Class A (dBuV)		Class B (dBuV)	
	Quasi-peak	Average	Quasi-peak	Average
0.15 -0.5	79.00	66.00	66 - 56 *	56 - 46 *
0.50 -5.0	73.00	60.00	56.00	46.00
5.0 -30.0	73.00	60.00	60.00	50.00

Note:

- (1) The tighter limit applies at the band edges.
- (2) The limit of " \* " marked band means the limitation decreases linearly with the logarithm of the frequency in the range.

The following table is the setting of the Receiver

Receiver Parameters	Setting
Attenuation	10 dB
Start Frequency	0.15 MHz
Stop Frequency	30 MHz
IF Bandwidth	9 kHz

### 3.1.2 TEST PROCEDURE

- a. The EUT was placed 0.4 meters from the horizontal ground plane with EUT being connected to the power mains through a line impedance stabilization network (LISN). All other support equipments powered from additional LISN(s). The LISN provide 50 Ohm/ 50uH of coupling impedance for the measuring instrument.
- b. Interconnecting cables that hang closer than 40 cm to the ground plane shall be folded back and forth in the center forming a bundle 30 to 40 cm long.
- c. I/O cables that are not connected to a peripheral shall be bundled in the center. The end of the cable may be terminated, if required, using the correct terminating impedance. The overall length shall not exceed 1 m.
- d. LISN at least 80 cm from nearest part of EUT chassis.
- e. For the actual test configuration, please refer to the related Item –EUT Test Photos.

### 3.1.3 TEST SETUP

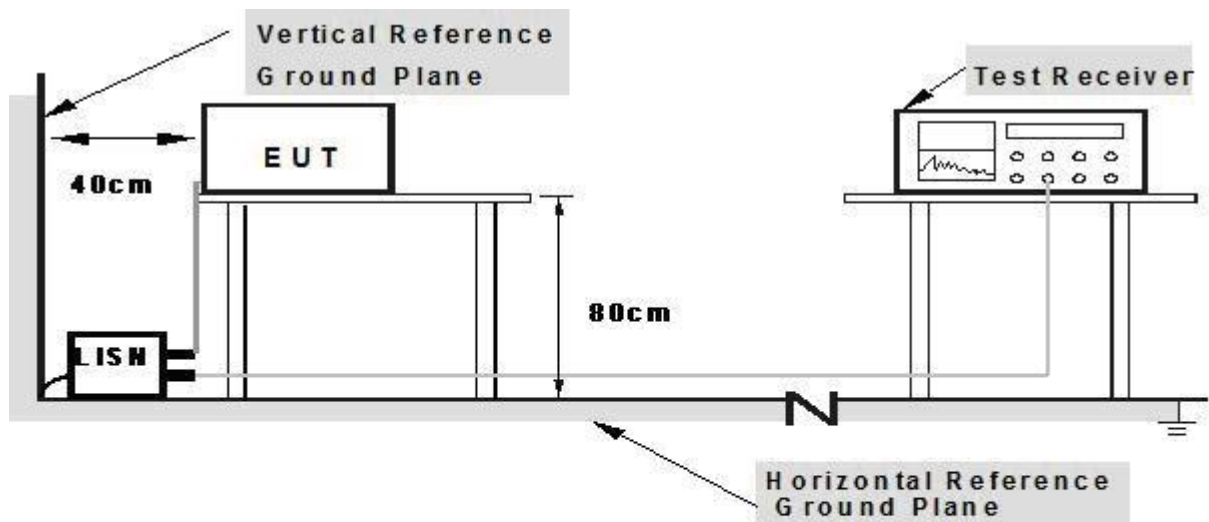

**Note: 1. Support units were connected to second LISN.**  
**2. Both of LISNs (AMN) are 80 cm from EUT and at least 80 cm from other units and other metal planes**

### 3.1.4 EUT OPERATING CONDITIONS

The EUT tested system was configured as the statements of 2.3 Unless otherwise a special operating condition is specified in the follows during the testing.

### 3.1.5 TEST RESULTS

EUT :	Receiver	Model Name. :	FD4003
Temperature :	26 °C	Relative Humidity :	54%
Pressure :	1010hPa	Test Date :	2012-12-23
Test Mode :	Charging and discharging	Phase :	L
Test Voltage :	DC 5V from PC 120V/60Hz		

Freq. (MHz)	Reading (dBuV)	Factor (dBuV)	Measurement (dBuV)	Limit (dBuV)	Over (dB)	Detector
0.1660	49.46	10.45	59.91	65.15	-5.24	QP
0.2180	33.76	10.44	44.20	52.89	-8.69	AVG
0.9700	31.25	10.41	41.66	46.00	-4.34	AVG
1.2980	33.85	10.41	44.26	56.00	-11.74	QP
10.3700	30.71	10.63	41.34	60.00	-18.66	QP
10.3700	27.68	10.63	38.31	50.00	-11.69	AVG

Remark:

1. All readings are Quasi-Peak and Average values.
2. Factor = Insertion Loss + Cable Loss.
3. N/A means All Data have pass Limit

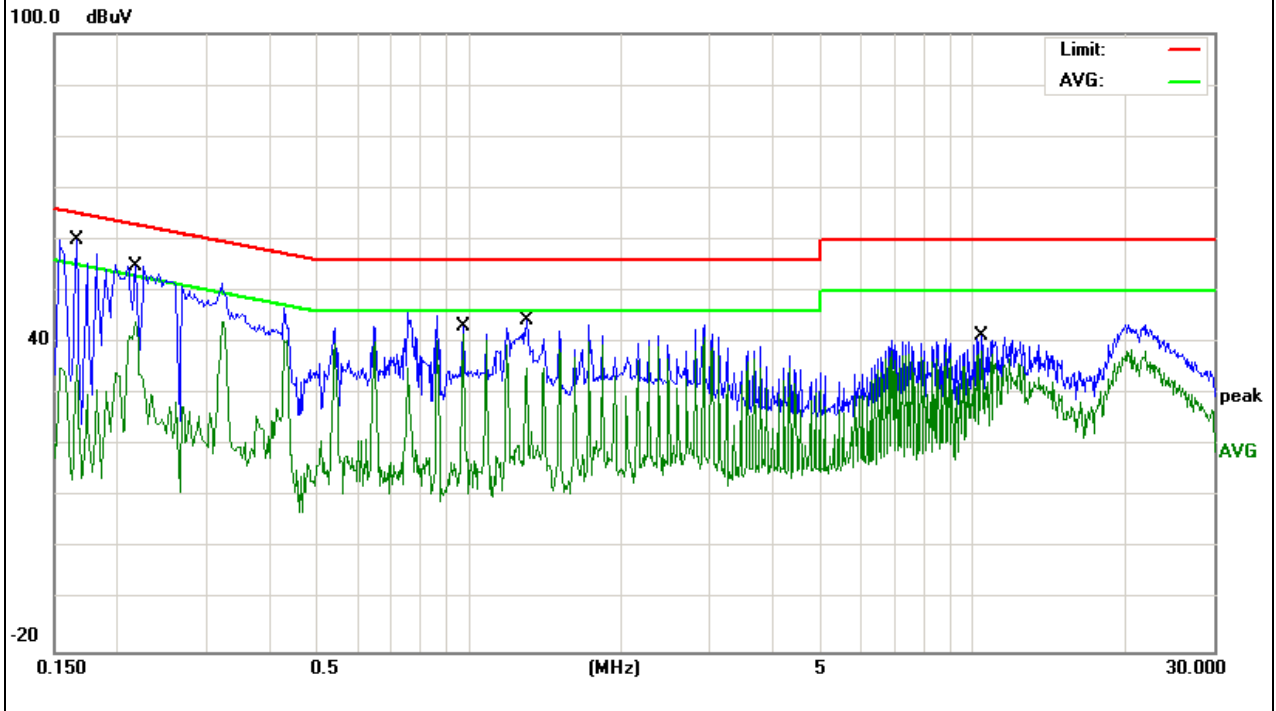

EUT :	Receiver	Model Name. :	FD4003
Temperature :	26 °C	Relative Humidity :	54%
Pressure :	1010hPa	Test Date :	2012-12-23
Test Mode :	Charging and discharging	Phase :	N
Test Voltage :	DC 5V from PC 120V/60Hz		

Freq. (MHz)	Reading (dBuV)	Factor (dBuV)	Measurement (dBuV)	Limit (dBuV)	Over (dB)	Detector
0.1660	49.81	10.34	60.15	65.15	-5.00	QP
0.2140	32.17	10.43	42.60	53.04	-10.44	AVG
1.1900	33.68	10.45	44.13	56.00	-11.87	QP
1.6220	31.61	10.44	42.05	46.00	-3.95	AVG
12.5340	30.03	10.71	40.74	50.00	-9.26	AVG
13.0740	32.76	10.72	43.48	60.00	-16.52	QP

Remark:

1. All readings are Quasi-Peak and Average values.
2. Factor = Insertion Loss + Cable Loss.
3. N/A means All Data have pass Limit

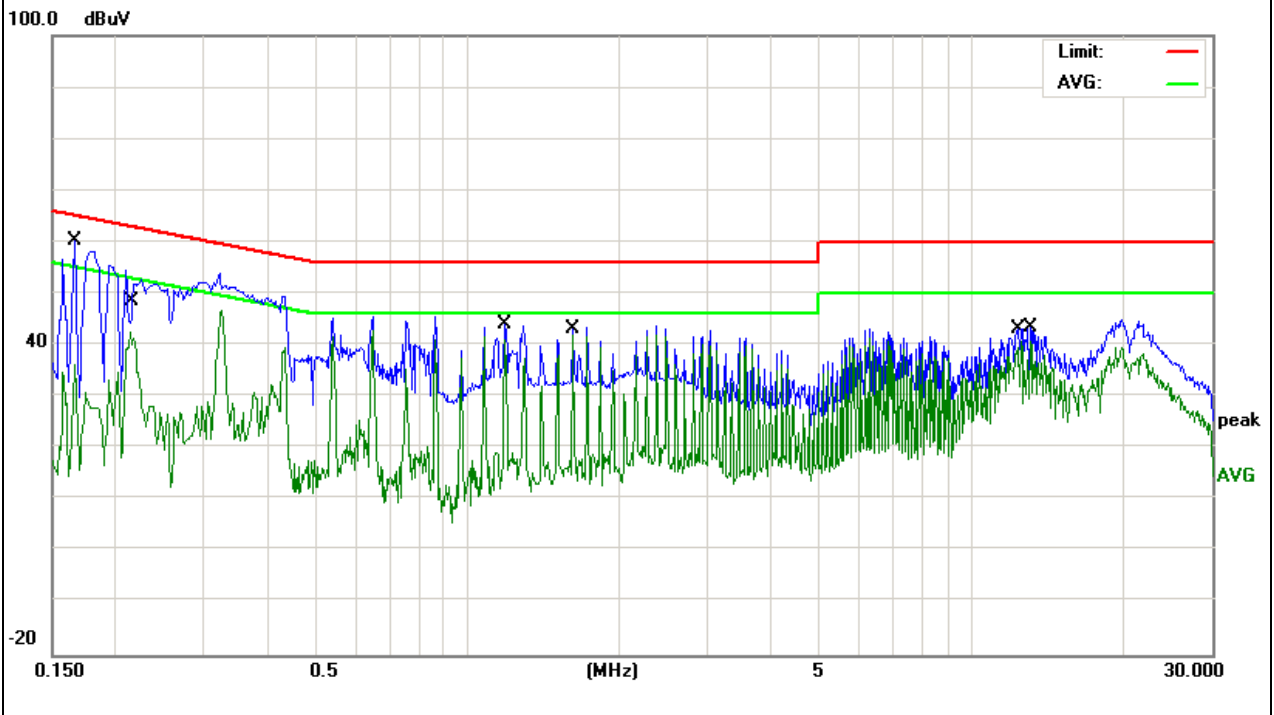

### 3.2 RADIATED EMISSION MEASUREMENT

#### 3.2.1 LIMITS OF RADIATED EMISSION MEASUREMENT

FREQUENCY (MHz)	Class A (at 10m)	Class B (at 3m)
	dBuV/m	dBuV/m
30 ~ 88	39.0	40.0
88 ~ 216	43.5	43.5
216 ~ 960	46.5	46.0
Above 960	49.5	54.0

Notes:

- (1) The limit for radiated test was performed according to as following:  
FCC PART 15B /ICES-003.
- (2) The tighter limit applies at the band edges.
- (3) Emission level (dBuV/m)=20log Emission level (uV/m).

#### 3.2.2 TEST PROCEDURE

- a. The measuring distance of at 10 m shall be used for measurements at frequency up to 1GHz. For frequencies above 1GHz, any suitable measuring distance may be used.
- b. The EUT was placed on the top of a rotating table 0.8 meters above the ground at a 10 meter open area test site. The table was rotated 360 degrees to determine the position of the highest radiation.
- c. The height of the equipment or of the substitution antenna shall be 0.8 m; the height of the test antenna shall vary between 1 m to 4 m. Both horizontal and vertical polarizations of the antenna are set to make the measurement.
- d. The initial step in collecting conducted emission data is a spectrum analyzer peak detector mode pre-scanning the measurement frequency range. Significant peaks are then marked and then Quasi Peak detector mode re-measured, above 1G Average detector mode will be instead.
- e. If the Peak Mode measured value compliance with and lower than Quasi Peak Mode Limit, the EUT shall be deemed to meet QP(AV) Limits and then no additional QP Mode measurement performed.
- f. For the actual test configuration, please refer to the related Item –EUT Test Photos.

### 3.2.3 TEST SETUP

#### (A) Radiated Emission Test Set-Up Frequency Below 1 GHz

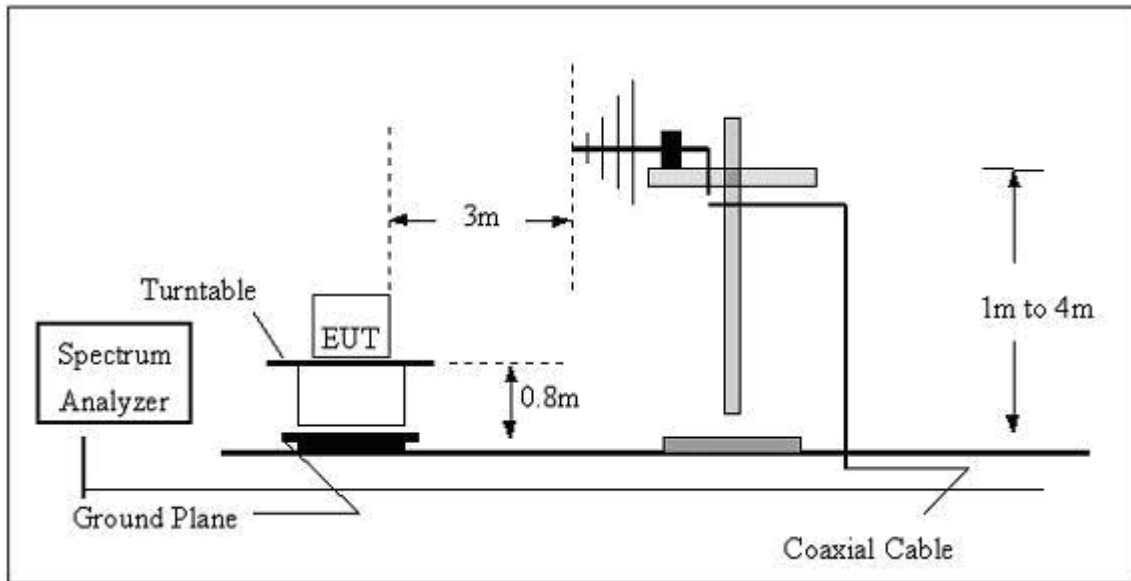

#### (B) Radiated Emission Test Set-Up Frequency Above 1GHz

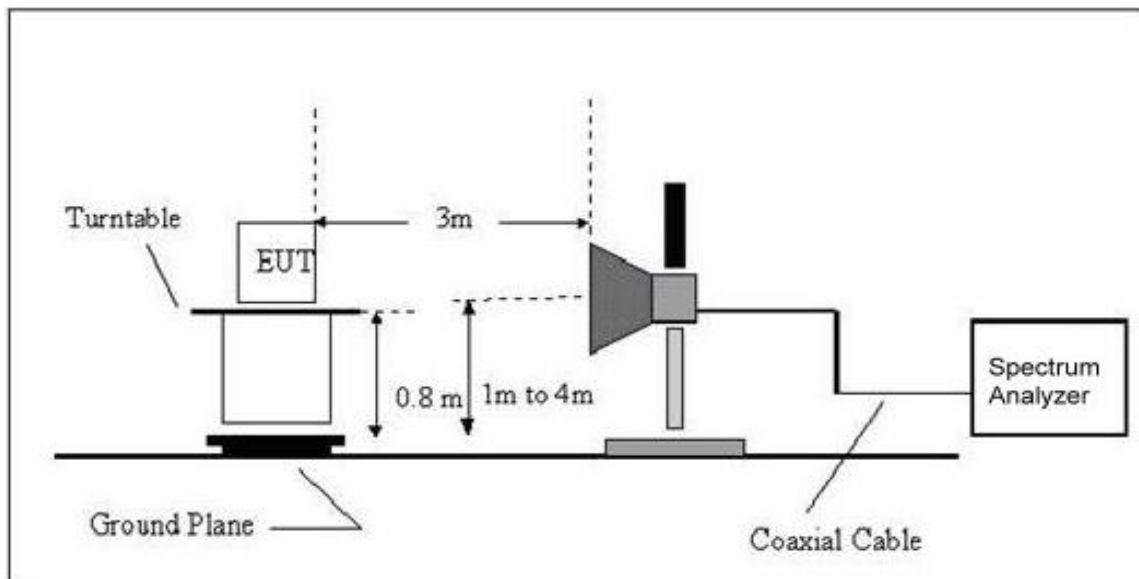

### 3.2.4 EUT OPERATING CONDITIONS

The EUT tested system was configured as the statements of **2.3** Unless otherwise a special operating condition is specified in the follows during the testing.



3.2.5 TEST RESULTS (Blow 30MHZ)

EUT :	Receiver	Model Name. :	FD4003
Temperature :	20 °C	Relative Humidity :	48%
Pressure :	1010 hPa	Test Voltage :	DC 5V from PC 120V/60Hz
Test Mode :	RX	Polarization :	--

Freq.	Reading	Limit	Margin	State
(MHz)	(dBuV/m)	(dBuV/m)	(dB)	P/F
--	--	--	--	PASS
--	--	--	--	PASS

**NOTE:**

The amplitude of spurious emissions which are attenuated by more than 20dB below the permissible value has no need to be reported.

Distance extrapolation factor =  $20 \log (\text{specific distance}/\text{test distance})$ (dB);

Limit line = specific limits(dBuv) + distance extrapolation factor.

### 3.2.6 TEST RESULTS

EUT :	Receiver	Model Name :	FD4003
Temperature :	24 °C	Relative Humidity :	54%
Pressure :	1010 hPa	Test Date :	2012-12-23
Test Mode :	RX	Polarization :	Horizontal
Test Power :	DC 5V from PC 120V/60Hz		

Freq. (MHz)	Reading (dBuV)	Factor (dBuV)	Measurement (dBuV)	Limit (dBuV)	Over (dB)	Detector
52.7599	27.30	6.92	34.22	40.00	-5.78	QP
190.4050	21.46	8.74	30.20	40.00	-9.80	QP
346.8091	26.05	15.28	41.33	47.00	-5.67	QP

Remark:

1. All readings are Quasi-Peak and Average values.
2. Factor = Antenna Factor + Cable Loss.
3. N/A means All Data have pass Limit

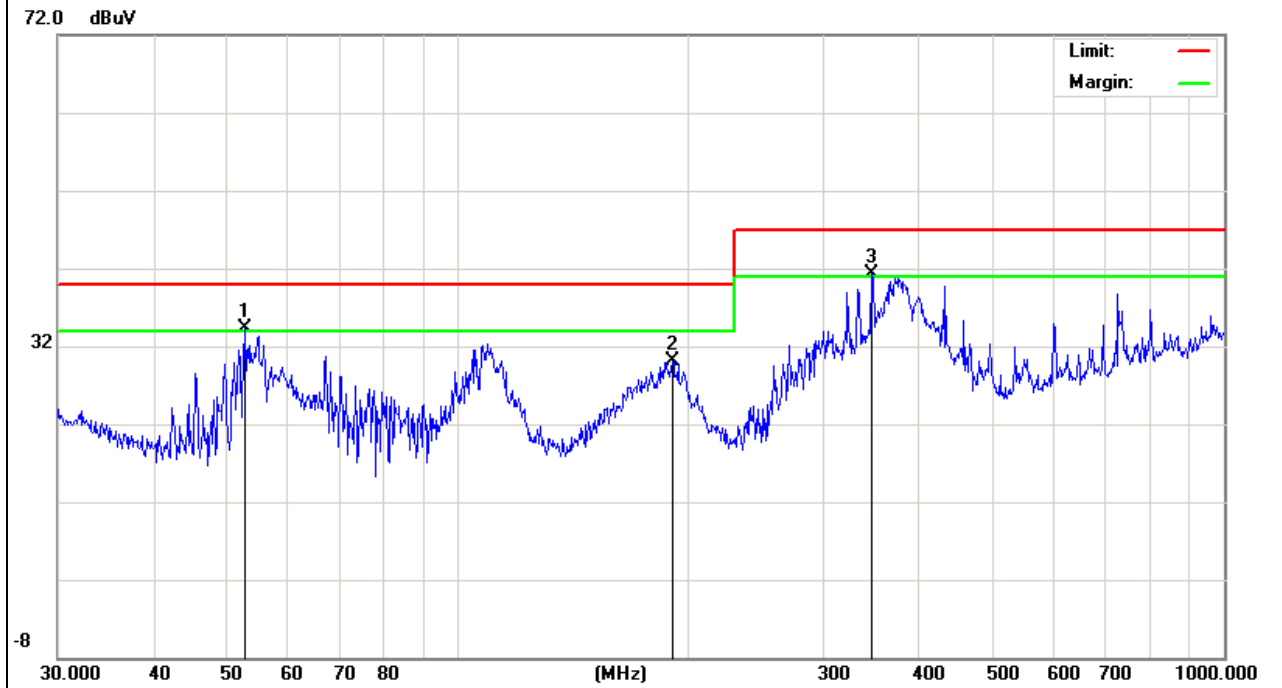

EUT :	Receiver	Model Name :	FD4003
Temperature :	24 °C	Relative Humidity :	54%
Pressure :	1010 hPa	Test Date :	2012-12-23
Test Mode :	RX	Polarization :	Vertical
Test Power :	DC 5V from PC 120V/60Hz		

Freq. (MHz)	Reading (dBuV)	Factor (dBuV)	Measurement (dBuV)	Limit (dBuV)	Over (dB)	Detector
123.6984	23.03	11.87	34.90	40.00	-5.10	QP
172.5988	26.55	9.85	36.40	40.00	-3.60	QP
263.8190	26.41	13.99	40.40	47.00	-6.60	QP

Remark:

1. All readings are Quasi-Peak and Average values.
2. Factor = Antenna Factor + Cable Loss.
3. N/A means All Data have pass Limit

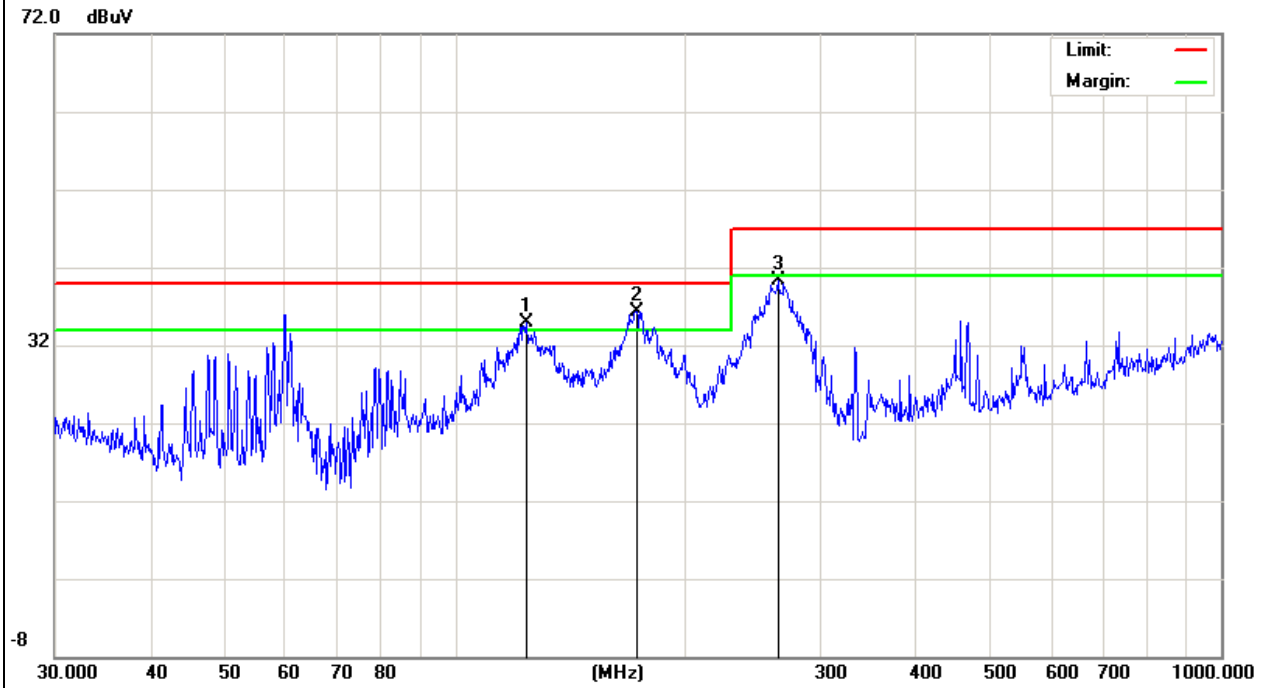

## 3.2.7 TEST RESULTS(Above 1GHz)

EUT :	Receiver	Model Name :	FD4003
Temperature :	24 °C	Relative Humidity :	54%
Pressure :	1010 hPa	Test Date :	N/A
Test Mode :	N/A		
Test Power :	N/A		

**4. EUT TEST PHOTO**

**Radiated Measurement Photos**

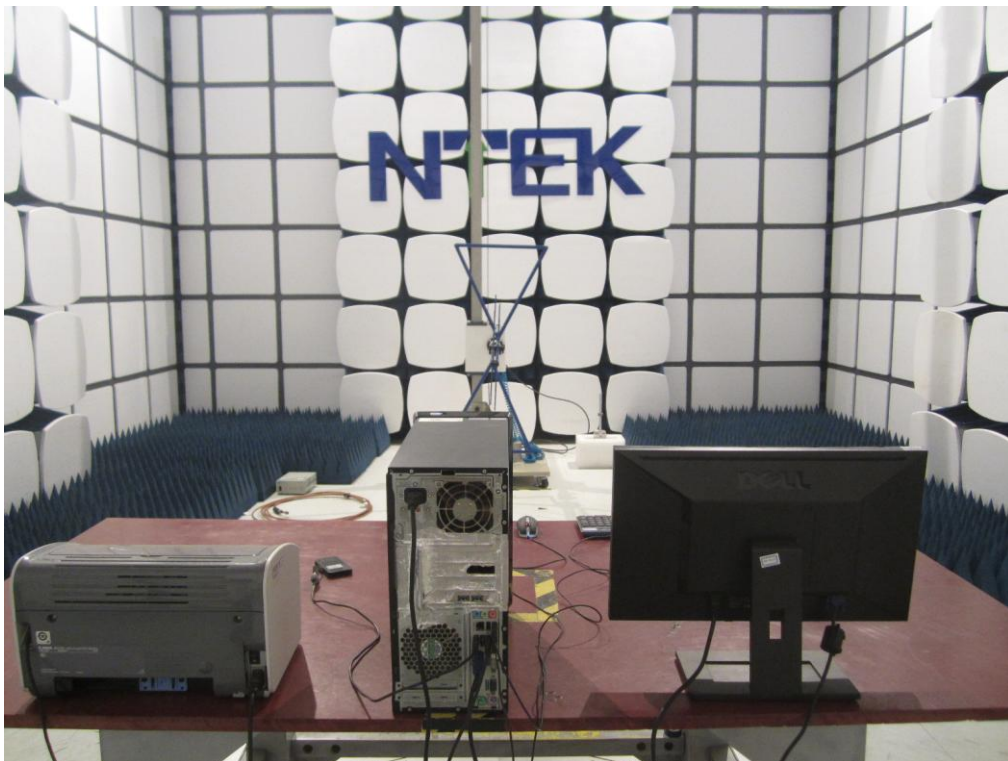
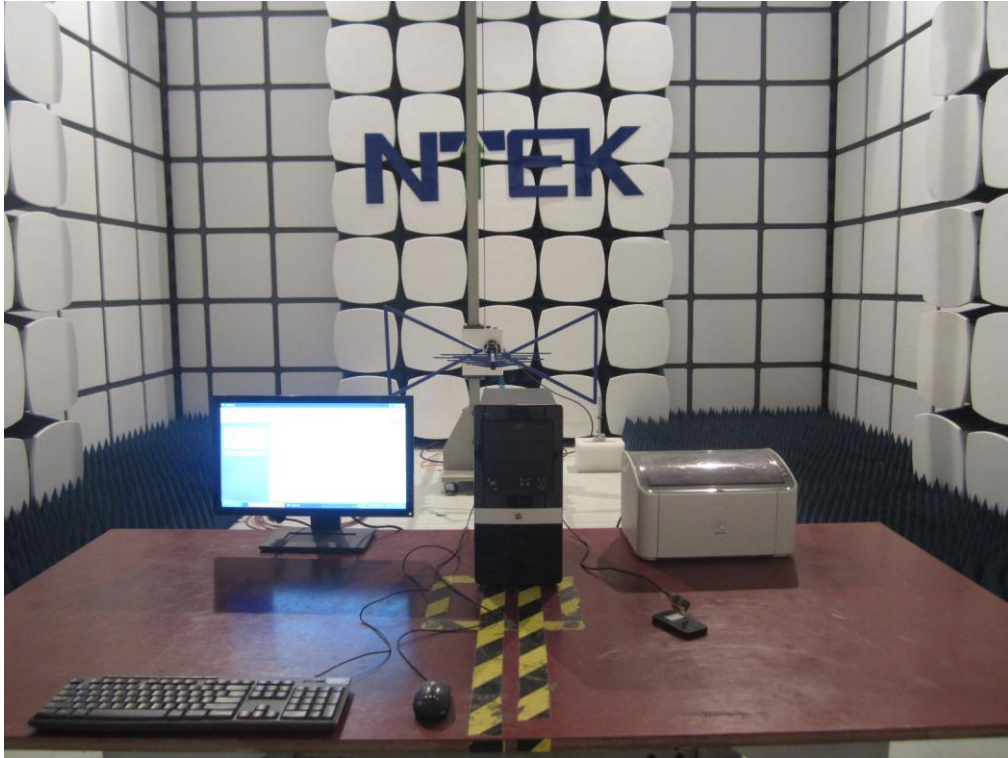

**Conducted Measurement Photos**

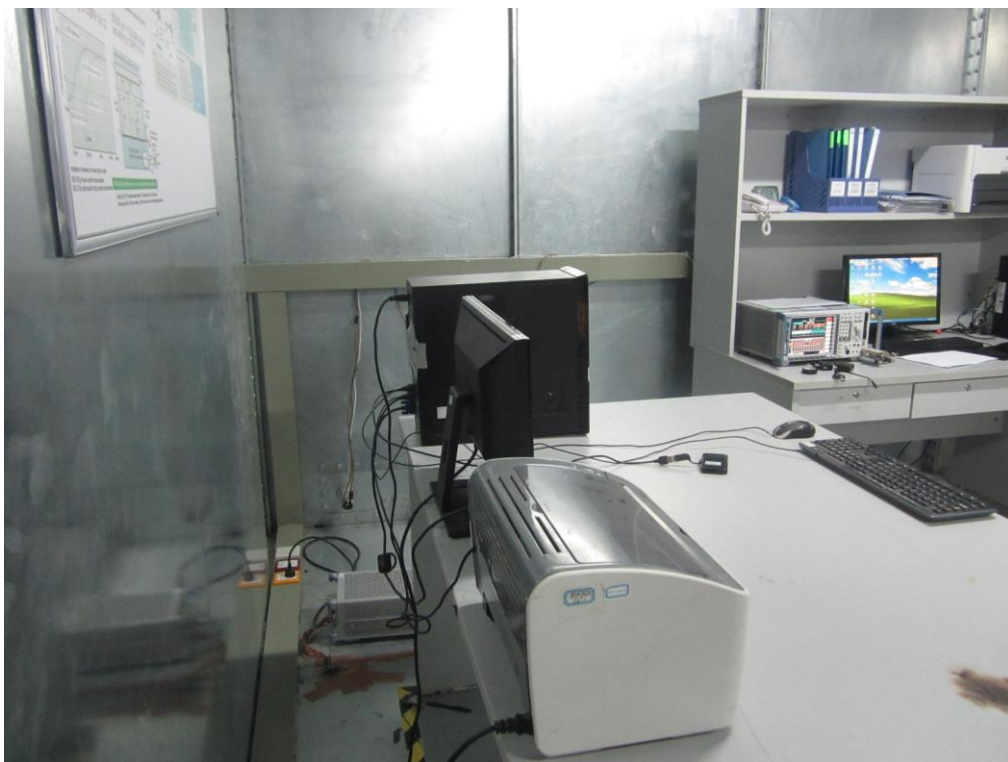

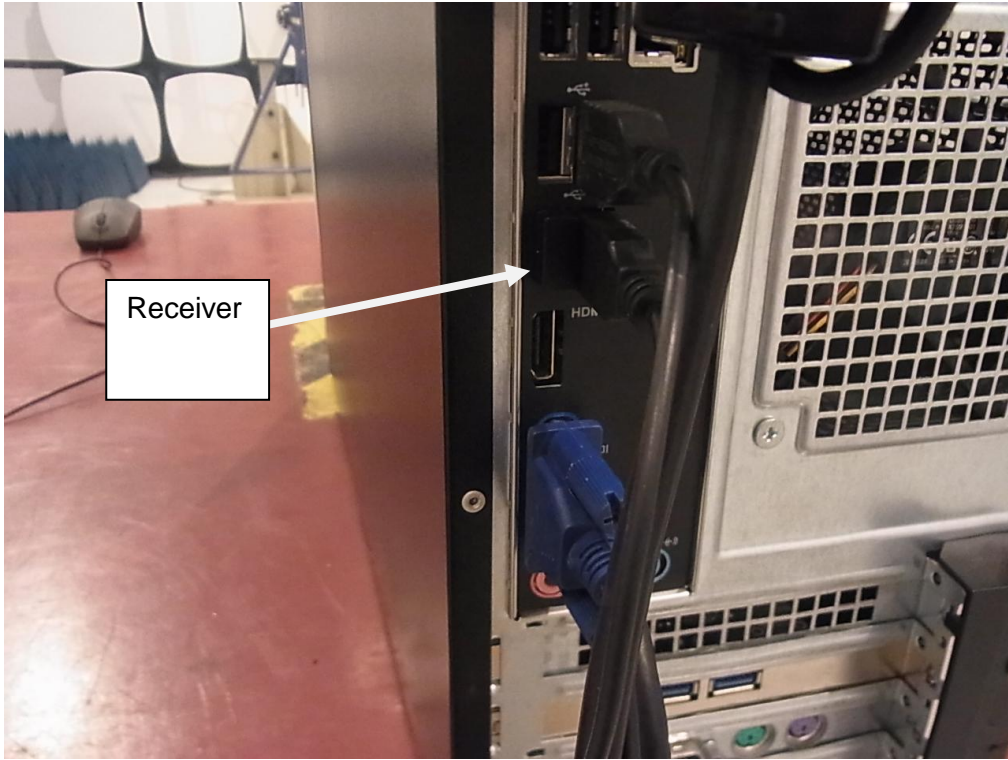

ATTACHMENT PHOTOGRAPHS OF EUT

Photo 1



Photo 2

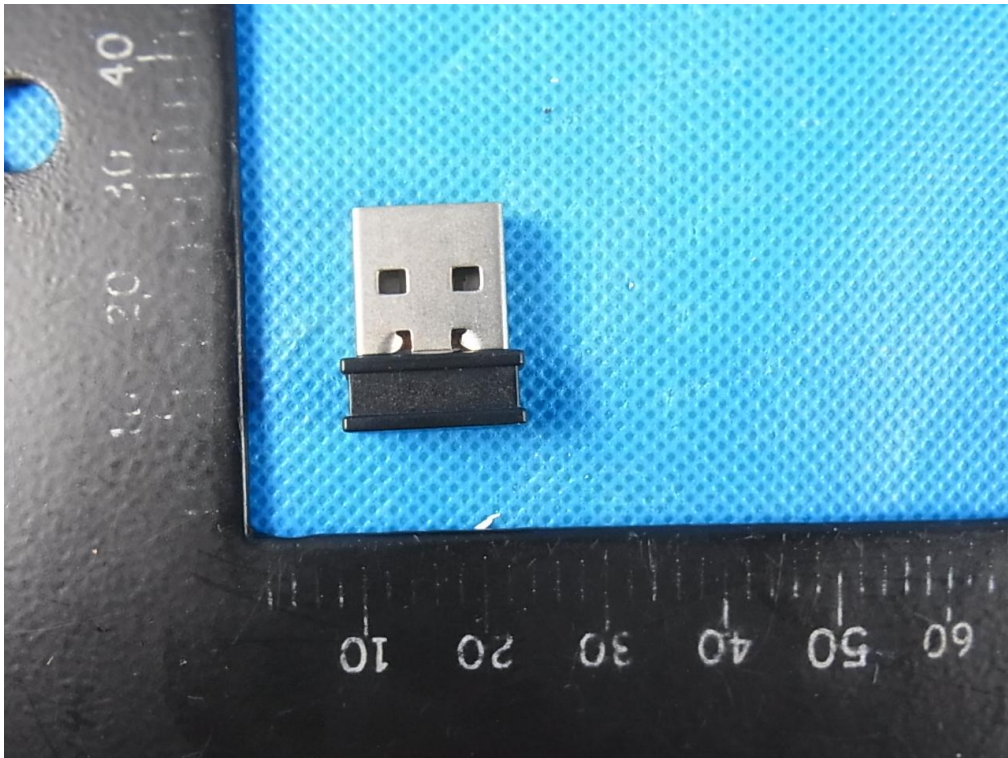



Photo 3

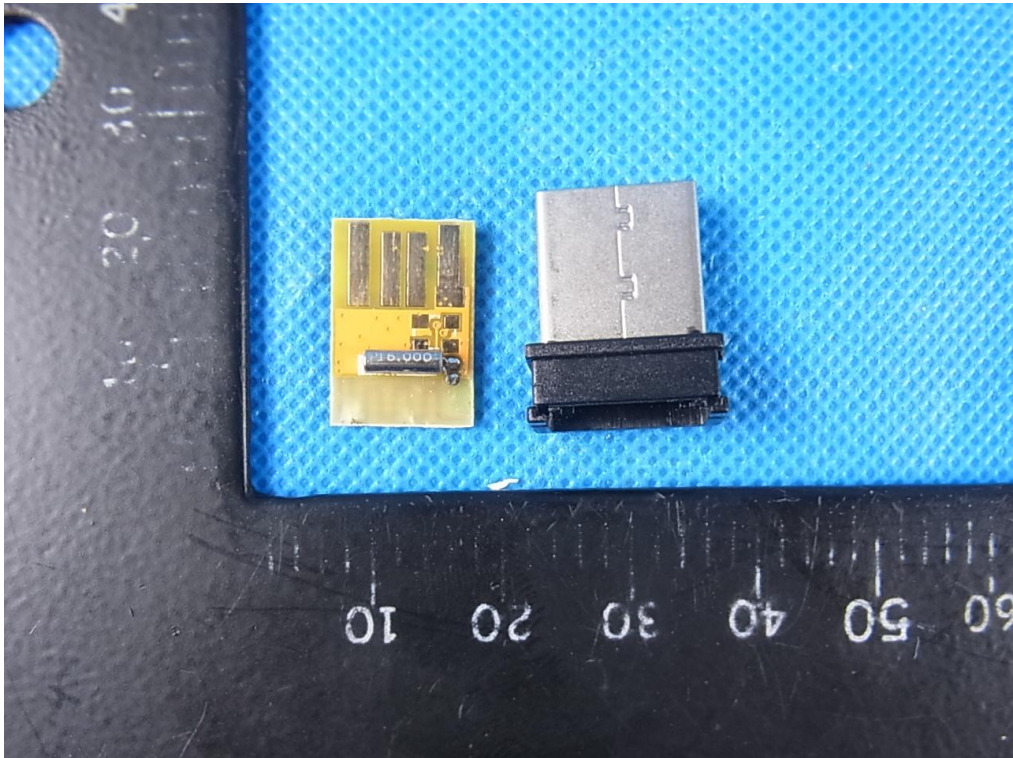

Photo 4

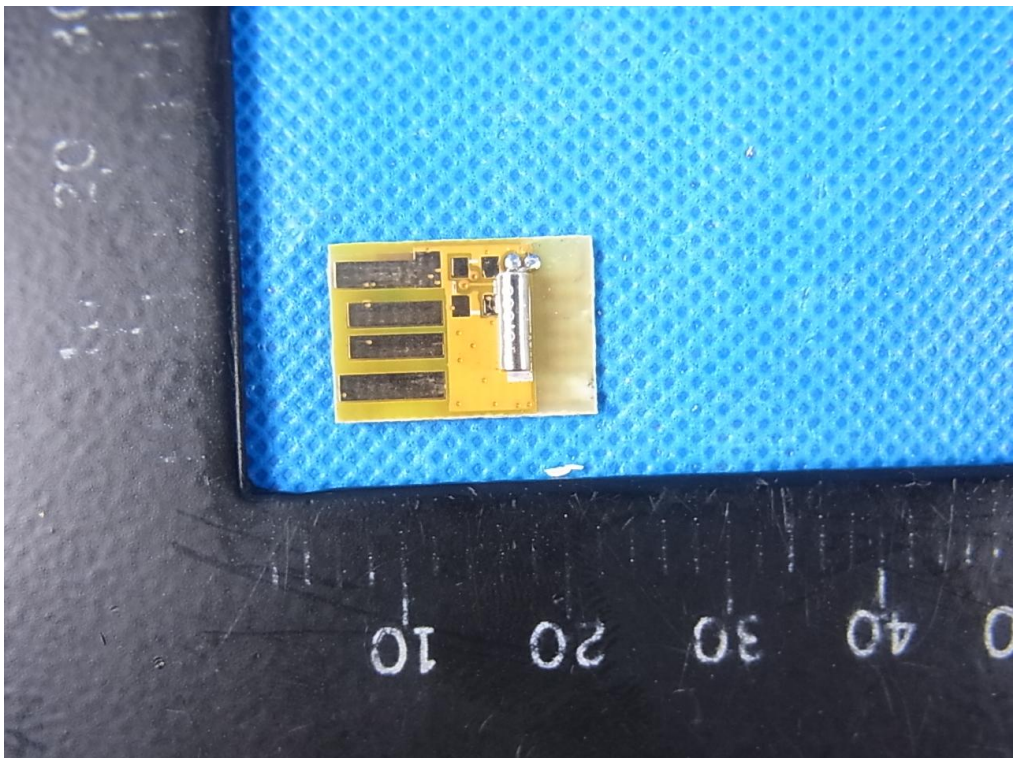

Photo 5

