



# FCC RADIO TEST REPORT

## FCC ID: Y36DU7119

**Product :** Car MP3

**Trade Name :** N/A

**Model Name :** DU7119

**Serial Model :** CA4525,IM513

**Report No. :** NTEK-2012DG0709057F

### Prepared for

China Etech Groups Ltd.

4th Floor,A3 Building,Huafeng centery Industrial park,Xixiang town,Baoan district,Shenzhen,Guangdong,China

### Prepared by

NTEK Testing Technology Co., Ltd.

1/F, Building E, Fenda Science Park, Sanwei Community,Xixiang Street  
Bao'an District, Shenzhen P.R. China

Tel.: +86-0755-61156588 Fax.: +86-0755-61156599

Website:www.ntek.org.cn

### TEST RESULT CERTIFICATION

**Applicant's name** ..... : China Etech Groups Ltd.  
**Address** ..... : 4th Floor,A3 Building,Huafeng centery Industrial park,Xixiang town,Baoan district,Shenzhen,Guangdong,China  
**Manufacture's Name**..... : China Etech Groups Ltd.  
**Address** ..... : 4th Floor,A3 Building,Huafeng centery Industrial park,Xixiang town,Baoan district,Shenzhen,Guangdong,China

**Product description**

**Product name** ..... : Car MP3  
**Model and/or type reference** : DU7119  
**Serial Model** : CA4525,IM513  
**Rating(s)** ..... : DC 12V

**Standards** ..... : FCC Part15.239

**Test procedure** ..... ANSI C63.4-2003

This device described above has been tested by NTEK, and the test results show that the equipment under test (EUT) is in compliance with the FCC requirements. And it is applicable only to the tested sample identified in the report.

This report shall not be reproduced except in full, without the written approval of NTEK, this document may be altered or revised by NTEK, personal only, and shall be noted in the revision of the document.

**Date of Test** ..... :  
**Date (s) of performance of tests** ..... : 03 Jul. 2012 ~08 Jul. 2012  
**Date of Issue**..... : 09 Jul. 2012  
**Test Result**..... : **Pass**

**Testing Engineer** : Apple Huang  
(Apple Huang)  
**Technical Manager** : Tom Zhang  
(Tom Zhang)  
**Authorized Signatory** : Bovey Yang  
(Bovey Yang)

<b>Table of Contents</b>	<b>Page</b>
<b>1 . SUMMARY OF TEST RESULTS</b>	<b>4</b>
1.1 TEST FACILITY	5
1.2 MEASUREMENT UNCERTAINTY	5
<b>2 . GENERAL INFORMATION</b>	<b>6</b>
2.1 GENERAL DESCRIPTION OF EUT	6
2.2 DESCRIPTION OF TEST MODES	7
2.3 BLOCK DIGRAM SHOWING THE CONFIGURATION OF SYSTEM TESTED	8
2.4 DESCRIPTION OF SUPPORT UNITS(CONDUCTED MODE)	9
2.5 EQUIPMENTS LIST FOR ALL TEST ITEMS	10
<b>3 . ANTENNA REQUIREMENT</b>	<b>11</b>
3.1 STANDARD REQUIREMENT	11
3.2 EUT ANTENNA	11
3.3 CONDUCTED EMISSION MEASUREMENT	12
3.3.1 POWER LINE CONDUCTED EMISSION LIMITS	12
3.3.2 TEST PROCEDURE	13
3.3.3 DEVIATION FROM TEST STANDARD	13
3.3.4 TEST SETUP	13
3.2.5 TEST RESULT	14
3.4 RADIATED EMISSION MEASUREMENT	15
3.4.1 RADIATED EMISSION LIMITS	15
3.4.2 TEST PROCEDURE	16
3.4.3 DEVIATION FROM TEST STANDARD	16
3.4.4 TEST SETUP	17
3.4.5 TEST RESULTS (BLOW 30MHZ)	19
3.4.6 TEST RESULTS (BETWEEN 30 - 1000 MHZ)	20
<b>4 . BANDWIDTH TEST</b>	<b>26</b>
4.1 TEST PROCEDURE	26
4.2 DEVIATION FROM STANDARD	26
4.3 TEST SETUP	26
4.4 TEST RESULTS	27
<b>5 . EUT TEST PHOTO</b>	<b>30</b>
<b>APPENDIX-PHOTOGRAPHS OF EUT CONSTRUCTIONAL DETAILS</b>	

### 1. SUMMARY OF TEST RESULTS

Test procedures according to the technical standards:

FCC Part15, Subpart C (15.239)			
Standard Section	Test Item	Judgment	Remark
15.207	Conducted Emission	Pass	
15.203	Antenna Requirement	Pass	
15.239	Radiated Spurious Emission	Pass	
15.239	Occupied Bandwidth	Pass	

## 1.1 TEST FACILITY

NTEK Testing Technology Co., Ltd

Add. : 1/F, Building E, Fenda Science Park, Sanwei Community, Xixiang Street, Bao'an District, Shenzhen P.R. China.

FCC FRN Registration No.:238937; IC Registration No.:9270A-1

CNAS Registration No.:L5516

## 1.2 MEASUREMENT UNCERTAINTY

The reported uncertainty of measurement  $y \pm U$ , where expanded uncertainty  $U$  is based on a standard uncertainty multiplied by a coverage factor of  $k=2$ , providing a level of confidence of approximately **95 %**.

No.	Item	Uncertainty
1	Conducted Emission Test	$\pm 1.38\text{dB}$
2	RF power,conducted	$\pm 0.16\text{dB}$
3	Spurious emissions,conducted	$\pm 0.21\text{dB}$
4	All emissions,radiated(<1G)	$\pm 4.68\text{dB}$
5	All emissions,radiated(>1G)	$\pm 4.89\text{dB}$
6	Temperature	$\pm 0.5^{\circ}\text{C}$
7	Humidity	$\pm 2\%$

## 2. GENERAL INFORMATION

### 2.1 GENERAL DESCRIPTION OF EUT

Equipment	Car MP3	
Trade Name	N/A	
Model Name	DU7119	
Serial Model	CA4525,IM513	
Model Difference	All the model is same just OEM different.	
Product Description	The EUT is a Car MP3	
	Product Type	Low Power Communication Device Transmitter
	Operation Frequency:	88.1-107.9MHz
	Modulation Type:	FM
	Number Of Channel	199CH.
	Antenna Designation:	Printed antenna
	Antenna Gain(Peak)	-2.32 dBi
	Output Power:	46.32 dBuV/m (AV Max.)
	Based on the application, features, or specification exhibited in User's Manual, the EUT is considered as an ITE/Computing Device. More details of EUT technical specification, please refer to the User's Manual.	
Channel List	N/A	
Adapter	N/A	
Battery	N/A	

Note:

1. For a more detailed features description, please refer to the manufacturer's specifications or the User's Manual.

## 2.2 DESCRIPTION OF TEST MODES

To investigate the maximum EMI emission characteristics generates from EUT, the test system was pre-scanning tested base on the consideration of following EUT operation mode or test configuration mode which possible have effect on EMI emission level. Each of these EUT operation mode(s) or test configuration mode(s) mentioned above was evaluated respectively.

Pretest Mode	Description
Mode 1	88.1MHz
Mode 2	98.1MHz
Mode 3	107.9MHz

For Conducted Emission	
Final Test Mode	Description
N/A	N/A

For Radiated Emission	
Final Test Mode	Description
Mode 1	88.1MHz
Mode 2	98.1MHz
Mode 3	107.9MHz

Note:

- (1) The measurements are performed at the highest, middle, lowest available channels.
- (2) The EUT use new battery.
- (3) During testing, the EUT was actively playing music set to its maximum audio volume in order to generate the worst case emissions (e.g. to generate the maximum bandwidth during bandwidth test). No test tones were used for testing. The tuning range of the EUT was manually verified and the conclusion is that it only works at selected channels within 88.1-107.9MHz, not below and not above this range.

### 2.3 BLOCK DIGRAM SHOWING THE CONFIGURATION OF SYSTEM TESTED

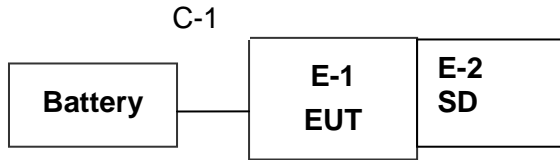



**2.4 DESCRIPTION OF SUPPORT UNITS(CONDUCTED MODE)**

The EUT has been tested as an independent unit together with other necessary accessories or support units. The following support units or accessories were used to form a representative test configuration during the tests.

Item	Equipment	Mfr/Brand	Model/Type No.	Series No.	Note
E-1	Car MP3	N/A	DU7119	N/A	EUT
E-2	SD Card	SANDISK	N/A	N/A	

Item	Shielded Type	Ferrite Core	Length	Note
C-1	NO	NO	0.7m	

Note:

- (1) The support equipment was authorized by Declaration of Confirmation.
- (2) For detachable type I/O cable should be specified the length in cm in 『Length』 column.

## 2.5 EQUIPMENTS LIST FOR ALL TEST ITEMS

### Radiation Test equipment

Item	Kind of Equipment	Manufacturer	Type No.	Serial No.	Calibrated until
1	Spectrum Analyzer	Agilent	E4407B	160400005	Jul. 06. 2013
2	Test Receiver	R&S	ESPI	101318	Jul. 06. 2013
3	Bilog Antenna	TESEQ	CBL6111D	31216	Jul. 06. 2013
4	50Ω Coaxial Switch	Anritsu	MP59B	6200264416	Jul. 06. 2013
5	Spectrum Analyzer	ADVANTEST	R3132	150900201	Jul. 06. 2013
6	Horn Antenna	EM	EM-AH-10180	2011071402	Jul. 06. 2013
7	Horn Ant	Schwarzbeck	BBHA 9170	9170-181	Jul. 06. 2013
8	Amplifier	EM	EM-30180	060538	Jul. 06. 2013
9	Loop Antenna	ARA	PLA-1030/B	1029	Jul. 06. 2013
10	Power Meter	R&S	NRVS	100696	Jul. 06. 2013

### Conduction Test equipment

Item	Kind of Equipment	Manufacturer	Type No.	Serial No.	Calibrated until
1	Test Receiver	R&S	ESCI	101160	Jul. 06. 2013
2	LISN	R&S	ENV216	101313	Jul. 06. 2013
3	LISN	EMCO	3816/2	00042990	Jul. 06. 2013
4	50Ω Coaxial Switch	Anritsu	MP59B	6200264417	Jul. 06. 2013
5	Passive Voltage Probe	R&S	ESH2-Z3	100196	Jul. 06. 2013
6	Absorbing clamp	R&S	MOS-21	100423	Jul. 06. 2013

### **3. ANTENNA REQUIREMENT**

#### **3.1 STANDARD REQUIREMENT**

15.203 requirement: For intentional device, according to 15.203: an intentional radiator shall be designed to ensure that no antenna other than that furnished by the responsible party shall be used with the device.

#### **3.2 EUT ANTENNA**

The EUT antenna is integral Antenna. It comply with the standard requirement.

### 3.3 CONDUCTED EMISSION MEASUREMENT

#### 3.3.1 POWER LINE CONDUCTED EMISSION Limits (Frequency Range 150KHz-30MHz)

FREQUENCY (MHz)	Class A (dBuV)		Class B (dBuV)		Standard
	Quasi-peak	Average	Quasi-peak	Average	
0.15 -0.5			66 - 56 *	56 - 46 *	CISPR
0.50 -5.0			56.00	46.00	CISPR
5.0 -30.0			60.00	50.00	CISPR

0.15 -0.5			66 - 56 *	56 - 46 *	LP002.
0.50 -5.0			56.00	46.00	LP002.
5.0 -30.0			60.00	50.00	LP002.

Note:

- (1) The tighter limit applies at the band edges.
- (2) The limit of " \* " marked band means the limitation decreases linearly with the logarithm of the frequency in the range.

The following table is the setting of the receiver

Receiver Parameters	Setting
Attenuation	10 dB
Start Frequency	0.15 MHz
Stop Frequency	30 MHz
IF Bandwidth	9 kHz

### 3.3.2 TEST PROCEDURE

- The EUT was placed 0.4 meters from the horizontal ground plane with EUT being connected to the power mains through a line impedance stabilization network (LISN). All other support equipments powered from additional LISN(s). The LISN provide 50 Ohm/ 50uH of coupling impedance for the measuring instrument.
- Interconnecting cables that hang closer than 40 cm to the ground plane shall be folded back and forth in the center forming a bundle 30 to 40 cm long.
- I/O cables that are not connected to a peripheral shall be bundled in the center. The end of the cable may be terminated, if required, using the correct terminating impedance. The overall length shall not exceed 1 m.
- LISN at least 80 cm from nearest part of EUT chassis.
- For the actual test configuration, please refer to the related Item –EUT Test Photos.

### 3.3.3 DEVIATION FROM TEST STANDARD

No deviation

### 3.3.4 TEST SETUP

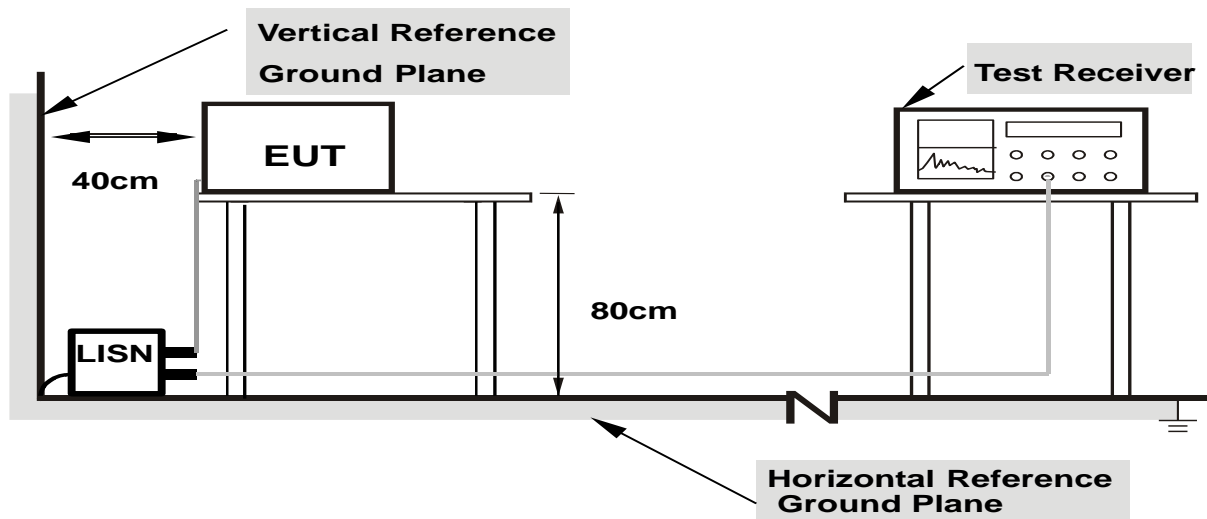

**Note: 1. Support units were connected to second LISN.**

**2. Both of LISNs (AMN) are 80 cm from EUT and at least 80 cm from other units and other metal planes**

**3.2.5 TEST RESULT**

EUT :	Car MP3	Model Name. :	DU7119
Temperature :	26 °C	Relative Humidity :	54%
Pressure :	1010hPa	Phase :	N/A
Test Voltage :	N/A	Test Mode :	N/A - denotes test is not applicable in this test report

### 3.4 RADIATED EMISSION MEASUREMENT

#### 3.4.1 Radiated Emission Limits ( FCC 15.209 )

Frequencies (MHz)	Field Strength (micorvolts/meter)	Measurement Distance (meters)
0.009~0.490	2400/F(KHz)	300
0.490~1.705	24000/F(KHz)	30
1.705~30.0	30	30
30~88	100	3
88~216	150	3
216~960	200	3
Above 960	500	3

Note:

- (1) The tighter limit applies at the band edges.
- (2) Emission level (dBuV/m)=20log Emission level (uV/m).

#### LIMITS OF RADIATED EMISSION MEASUREMENT ( FCC 15.239)

Frequency of Emission (MHz)	Field Strength of fundamental (dBμV/m)	
	Peak	Average
88-108	68	48

Notes:

- (1) Fcc part15.239 (b) The field strength of any emissions within the permitted 200 kHz band shall not exceed 250 microvolts/meter at 3 meters. The emission limit in this paragraph is based on measurement instrumentation employing an average detector. The provisions in Section 15.35 for limiting peak emissions apply.

Spectrum Parameter	Setting
Attenuation	Auto
Start Frequency	1000 MHz
Stop Frequency	10th carrier harmonic
RB / VB (emission in restricted band)	1MHz / 1MHz for Peak

Receiver Parameter	Setting
Attenuation	Auto
Start ~ Stop Frequency	9kHz~150kHz / RB 200Hz for QP
Start ~ Stop Frequency	150kHz~30MHz / RB 9kHz for QP
Start ~ Stop Frequency	30MHz~1000MHz / RB 120kHz for QP

### 3.4.2 TEST PROCEDURE

- a. The measuring distance of at 3 m shall be used for measurements at frequency up to 1GHz. For frequencies above 1GHz, any suitable measuring distance may be used.
- b. The EUT was placed on the top of a rotating table 0.8 meters above the ground at a 3m meter open area test site. The table was rotated 360 degrees to determine the position of the highest radiation.
- c. The height of the equipment or of the substitution antenna shall be 0.8 m; the height of the test antenna shall vary between 1 m to 4 m.
- d. The initial step in collecting conducted emission data is a spectrum analyzer peak detector mode pre-scanning the measurement frequency range. Significant peaks are then marked and then Quasi Peak detector mode re-measured.
- e. If the Peak Mode measured value compliance with and lower than Quasi Peak Mode Limit, the EUT shall be deemed to meet QP Limits and then no additional QP Mode measurement performed.
- f. For the actual test configuration, please refer to the related Item –EUT Test Photos.

Note:

Both horizontal and vertical antenna polarities were tested and performed pretest to three orthogonal axis. The worst case emissions were reported

### 3.4.3 DEVIATION FROM TEST STANDARD

No deviation



### 3.4.4 TEST SETUP

(A) Radiated Emission Test-Up Frequency Below 30MHz

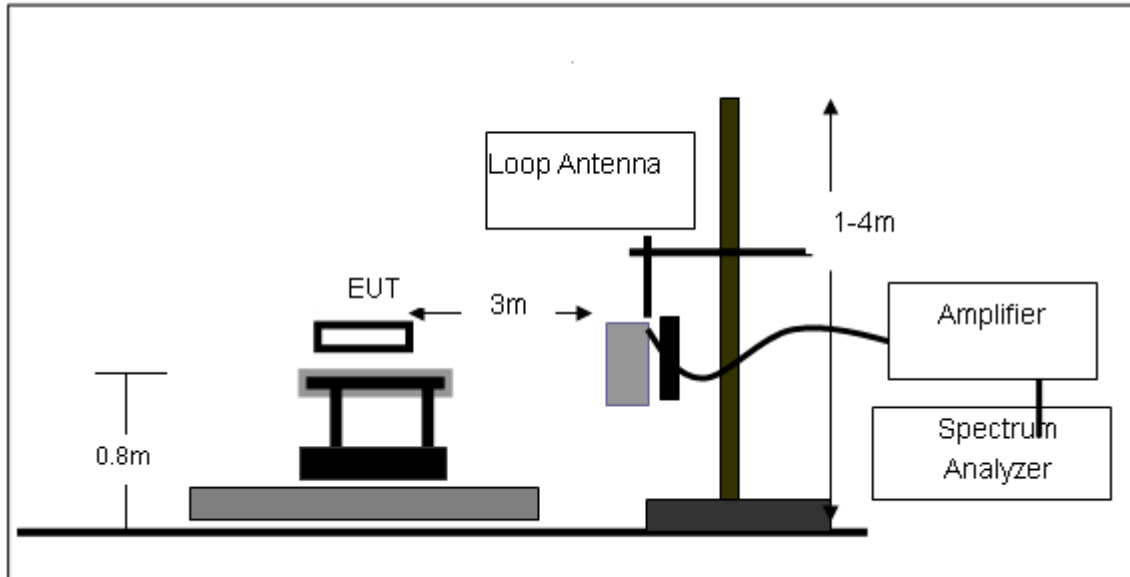

(B) Radiated Emission Test-Up Frequency 30MHz~1GHz

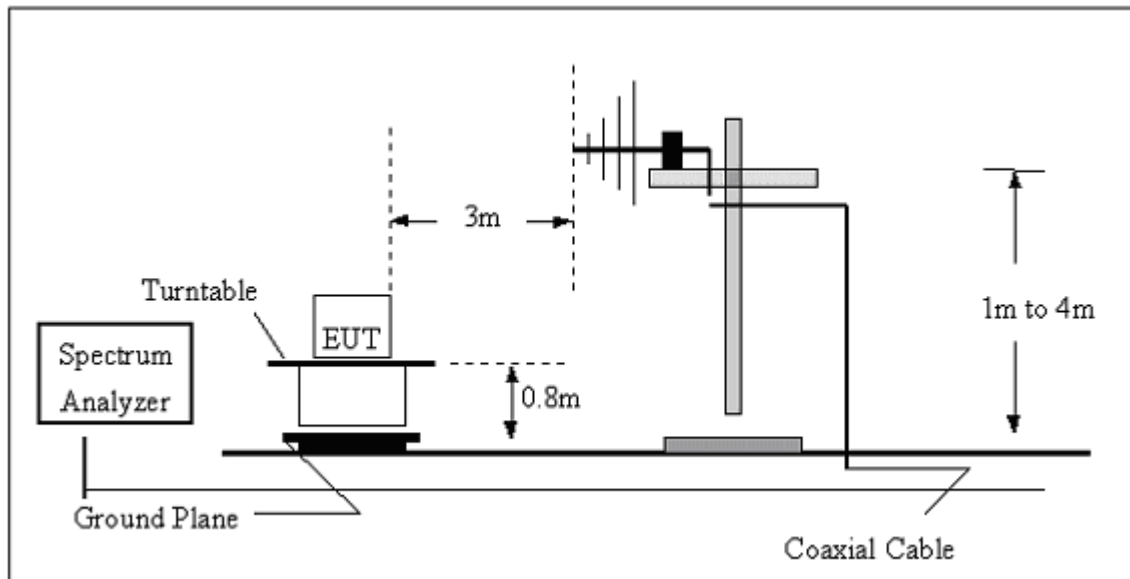

(C) Radiated Emission Test-Up Frequency Above 1GHz

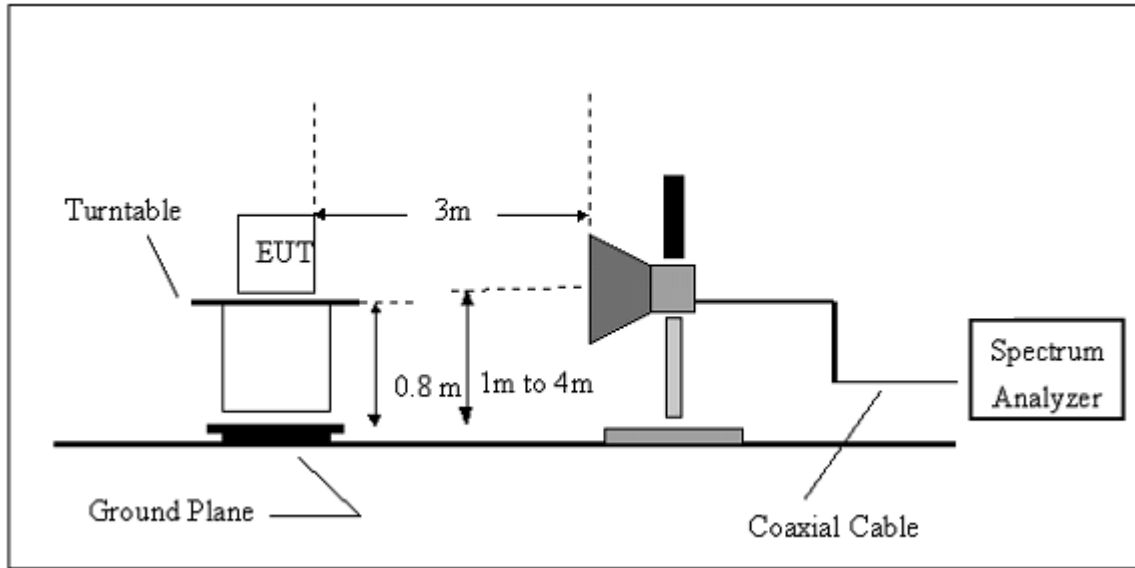

**3.4.5 TEST RESULTS (BLOW 30MHz)**

EUT :	Car MP3	Model Name. :	DU7119
Temperature :	20 °C	Relative Humidity :	48%
Pressure :	1010 hPa	Test Voltage :	DC 12V
Test Mode :	TX	Polarization :	--

Freq.	Reading	Limit	Margin	State
(MHz)	(dBuV/m)	(dBuV/m)	(dB)	P/F
--	--	--	--	PASS
--	--	--	--	PASS

**NOTE:**

The amplitude of spurious emissions which are attenuated by more than 20dB below the permissible value has no need to be reported.

Distance extrapolation factor =  $20 \log (\text{specific distance}/\text{test distance})$ (dB);

Limit line = specific limits(dBuv) + distance extrapolation factor.

### 3.4.6 TEST RESULTS (BETWEEN 30 – 1000 MHZ)

EUT :	Car MP3	Model Name :	DU7119
Temperature :	20 °C	Relative Humidity :	48%
Pressure :	1010 hPa	Test Voltage :	DC 12V
Test Mode :	88.1MHz	Polarization :	Vertical

Frequency (MHz)	Meter Reading (dBµV)	Factor (dB)	Emission Level (dBµV/m)	Limits (dBµV/m)	Margin (dB)	Detector Type
35.6699	13.93	15.36	29.29	40	-10.71	QP
69.45	25.28	5.93	31.21	40	-8.79	QP
88.1	43.06	9.09	52.15	68	-15.85	peak
88.1	37.23	9.09	46.32	48	-1.68	AVG
176.2	26.56	9.69	36.25	43.5	-7.25	QP
264.3	23.34	13.94	37.28	46	-8.72	QP

Remark:

1. Factor = Antenna Factor + Cable Loss – Pre-amplifier.

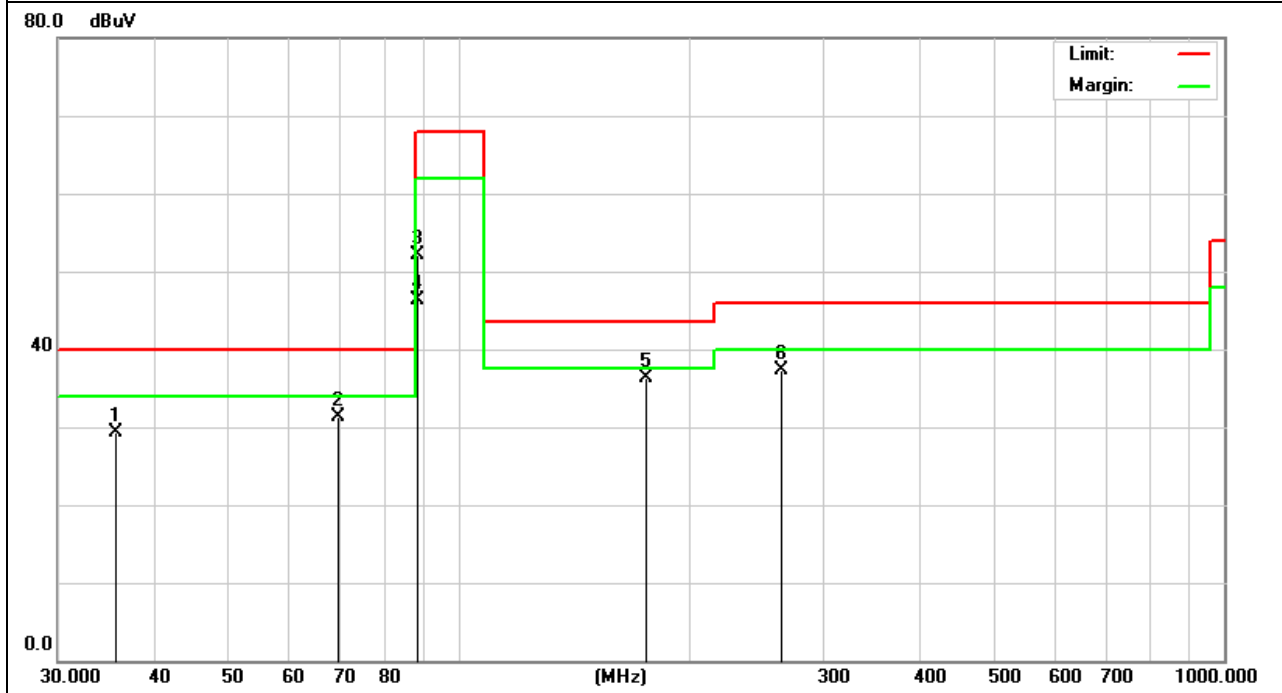

EUT :	Car MP3	Model Name :	DU7119
Temperature :	20 °C	Relative Humidity :	48%
Pressure :	1010 hPa	Test Voltage :	DC 12V
Test Mode :	88.1MHz	Polarization :	Horizontal

Frequency (MHz)	Meter Reading (dBµV)	Factor (dB)	Emission Level (dBµV/m)	Limits (dBµV/m)	Margin (dB)	Detector Type
50.12	17.07	8.12	25.19	40	-14.81	QP
70.45	29.02	6.09	35.11	40	-4.89	QP
88.1	40.1	9.09	49.19	68	-18.81	peak
88.1	35.24	9.09	44.33	48	-3.67	AVG
176.2	20.56	9.69	30.25	43.5	-13.25	QP
264.3	21.84	13.94	35.78	46	-10.22	QP

Remark:

1. Factor = Antenna Factor + Cable Loss – Pre-amplifier.

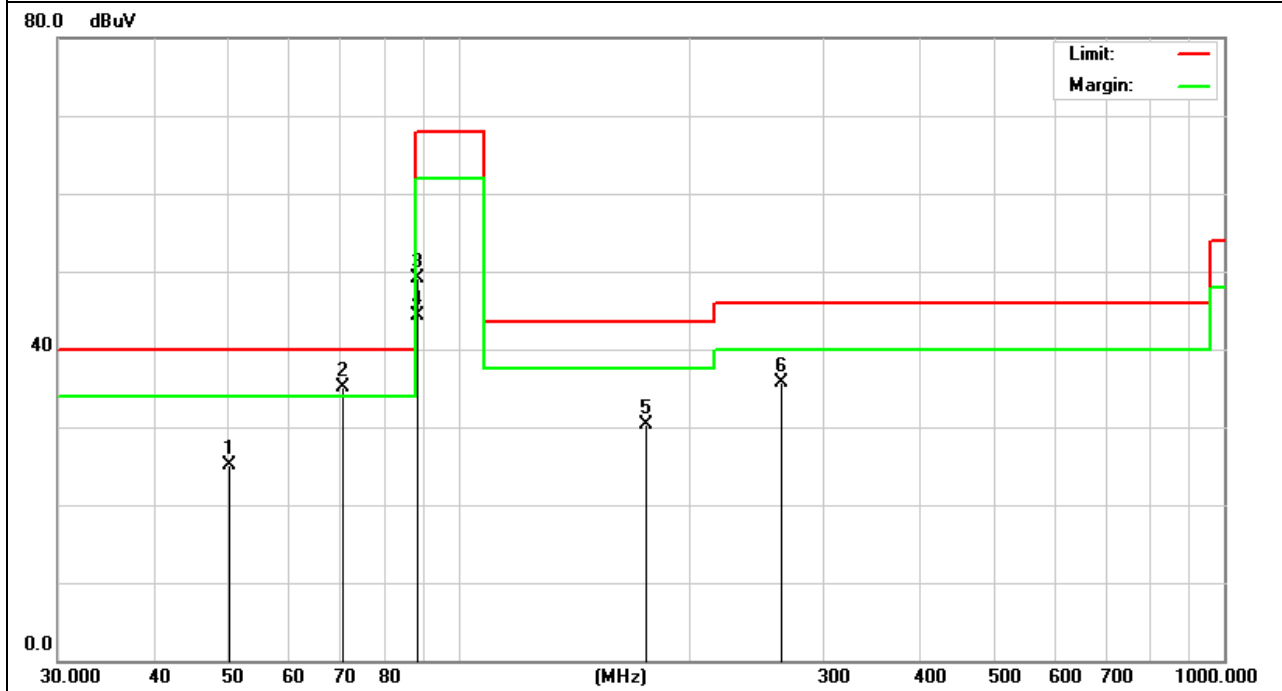

EUT :	Car MP3	Model Name :	DU7119
Temperature :	20 °C	Relative Humidity :	48%
Pressure :	1010 hPa	Test Voltage :	DC 12V
Test Mode :	98.1MHz	Polarization :	Vertical

Frequency (MHz)	Meter Reading (dBµV)	Factor (dB)	Emission Level (dBµV/m)	Limits (dBµV/m)	Margin (dB)	Detector Type
35.6699	13.93	15.36	29.29	40	-10.71	QP
69.45	25.28	5.93	31.21	40	-8.79	QP
98.1	40.89	10.3	51.19	68	-16.81	peak
98.1	35.59	10.3	45.89	48	-2.11	AVG
196.2	32.19	8.68	40.87	43.5	-2.63	QP
294.3	19.88	14.3	34.18	46	-11.82	QP

Remark:

1. Factor = Antenna Factor + Cable Loss – Pre-amplifier.

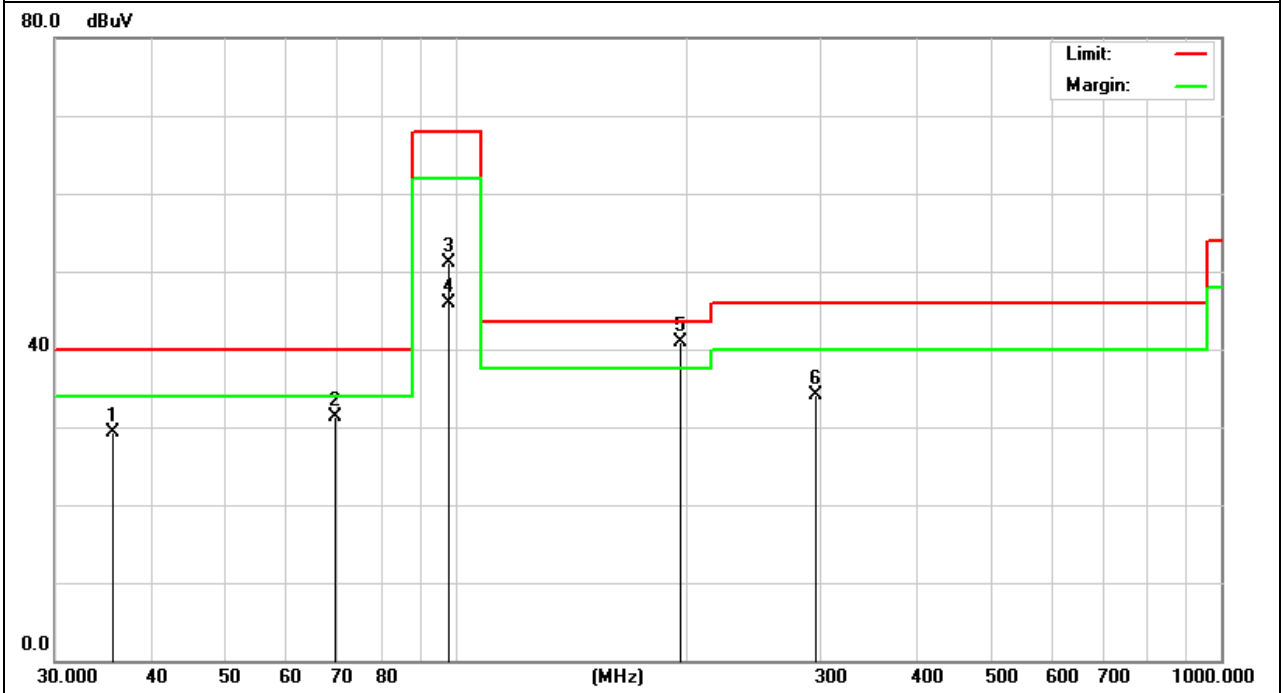

EUT :	Car MP3	Model Name :	DU7119
Temperature :	20 °C	Relative Humidity :	48%
Pressure :	1010 hPa	Test Voltage :	DC 12V
Test Mode :	98.1MHz	Polarization :	Horizontal

Frequency (MHz)	Meter Reading (dBμV)	Factor (dB)	Emission Level (dBμV/m)	Limits (dBμV/m)	Margin (dB)	Detector Type
50.12	17.07	8.12	25.19	40	-14.81	QP
70.45	29.02	6.09	35.11	40	-4.89	QP
98.1	42.48	10.3	52.78	68	-15.22	peak
98.1	34.43	10.3	44.73	48	-3.27	AVG
196.2	22.8	8.68	31.48	43.5	-12.02	QP
294.3	22.59	14.3	36.89	46	-9.11	QP

Remark:

1. Factor = Antenna Factor + Cable Loss – Pre-amplifier.

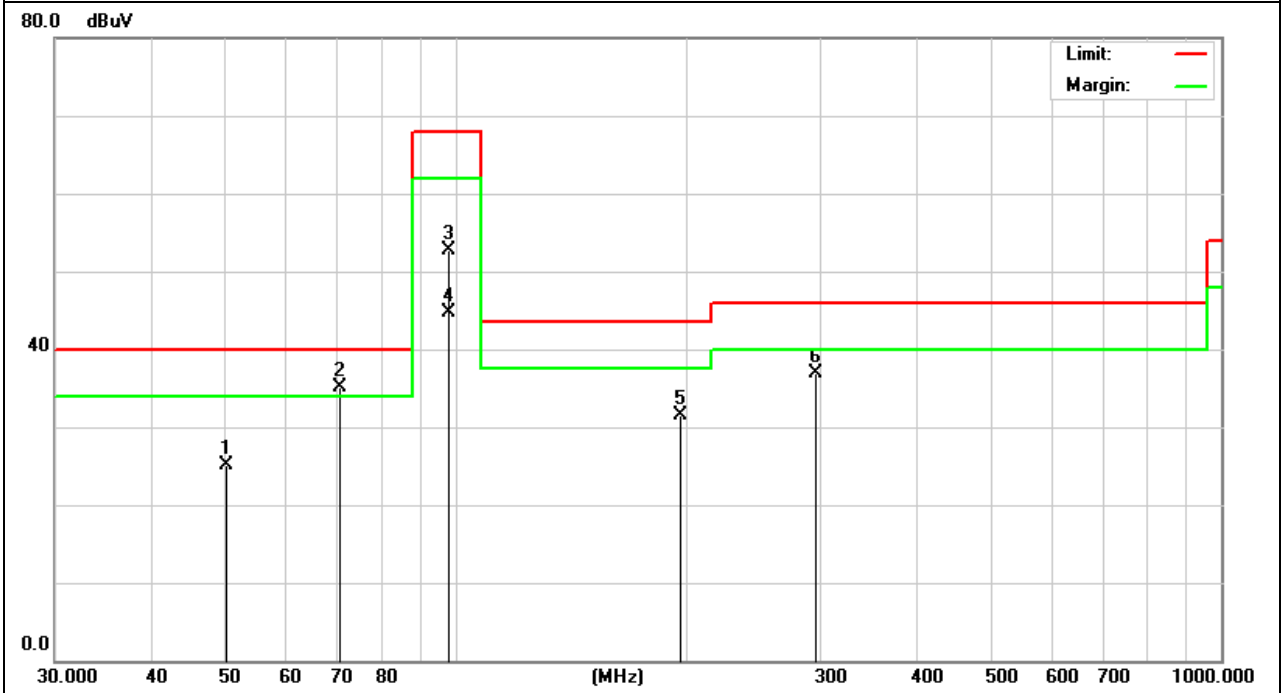

EUT :	Car MP3	Model Name :	DU7119
Temperature :	20 °C	Relative Humidity :	48%
Pressure :	1010 hPa	Test Voltage :	DC 12V
Test Mode :	107.9MHz	Polarization :	Vertical

Frequency (MHz)	Meter Reading (dBμV)	Factor (dB)	Emission Level (dBμV/m)	Limits (dBμV/m)	Margin (dB)	Detector Type
35.6699	13.93	15.36	29.29	40	-10.71	QP
69.45	25.28	5.93	31.21	40	-8.79	QP
107.9	41.67	11.21	52.88	68	-15.12	peak
107.9	35.06	11.21	46.27	48	-1.73	AVG
215.8	26.79	9.5	36.29	43.5	-7.21	QP
323.7	18.75	14.81	33.56	46	-12.44	QP

Remark:

1. Factor = Antenna Factor + Cable Loss – Pre-amplifier.

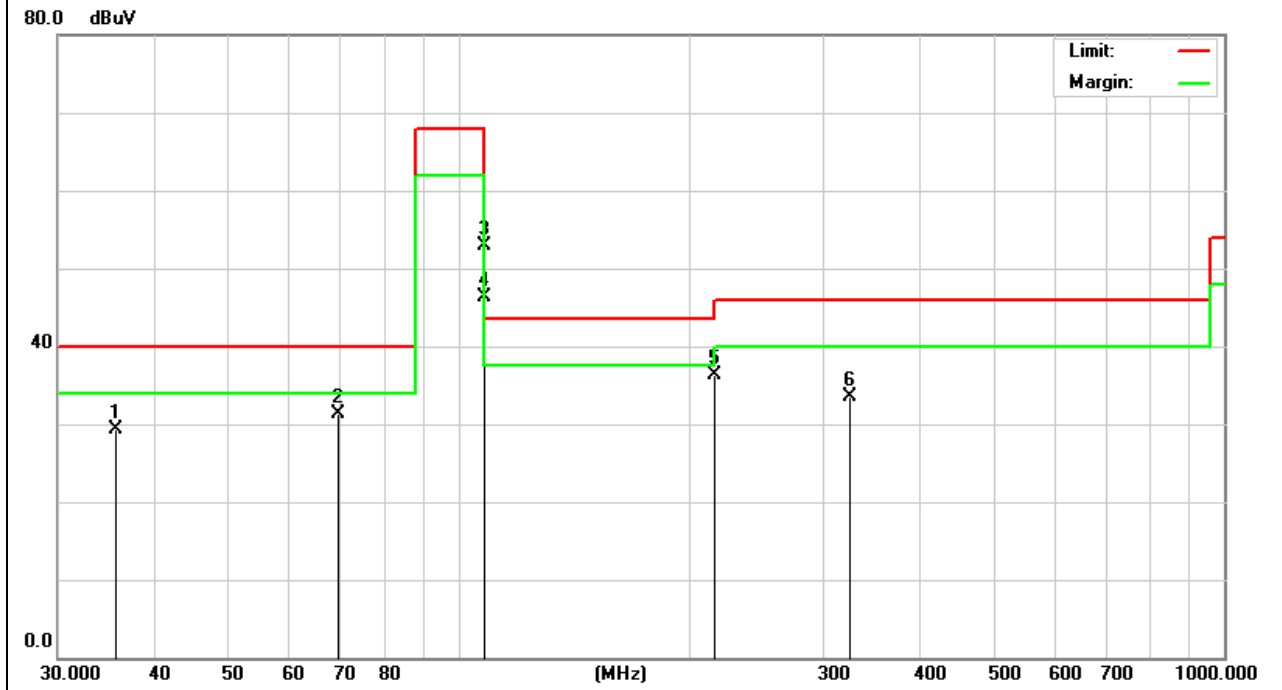



EUT :	Car MP3	Model Name :	DU7119
Temperature :	20 °C	Relative Humidity :	48%
Pressure :	1010 hPa	Test Voltage :	DC 12V
Test Mode :	107.9MHz	Polarization :	Horizontal

Frequency (MHz)	Meter Reading (dBµV)	Factor (dB)	Emission Level (dBµV/m)	Limits (dBµV/m)	Margin (dB)	Detector Type
50.12	17.07	8.12	25.19	40	-14.81	QP
70.45	29.02	6.09	35.11	40	-4.89	QP
107.9	43.08	11.21	54.29	68	-13.71	peak
107.9	34.77	11.21	45.98	48	-2.02	AVG
215.8	20.75	9.5	30.25	43.5	-13.25	QP
323.7	21.1	14.81	35.91	46	-10.09	QP

Remark:

1. Factor = Antenna Factor + Cable Loss – Pre-amplifier.

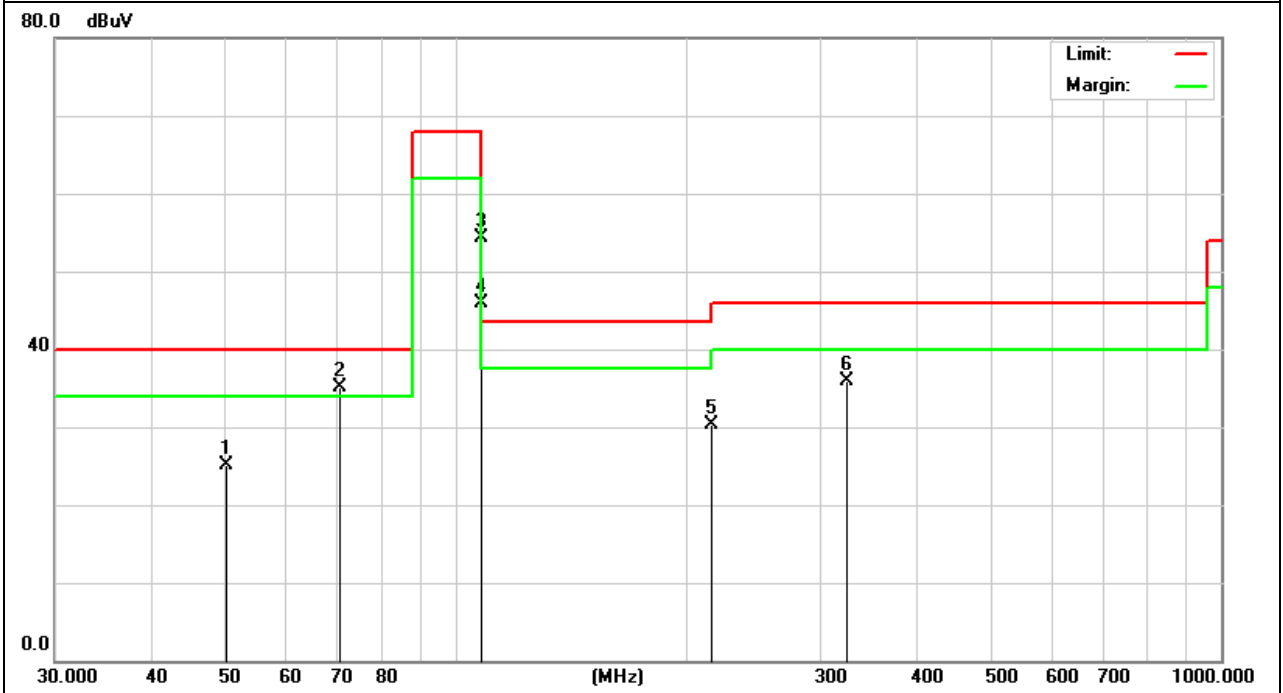

## 4. BANDWIDTH TEST

### 4.1 TEST PROCEDURE

- a. The EUT was directly connected to the spectrum analyzer and antenna output port as show in the block diagram below,
- b. Spectrum Setting : RBW= 10KHz, VBW $\geq$ RBW, Sweep time = Auto.

### 4.2 DEVIATION FROM STANDARD

No deviation.

### 4.3 TEST SETUP

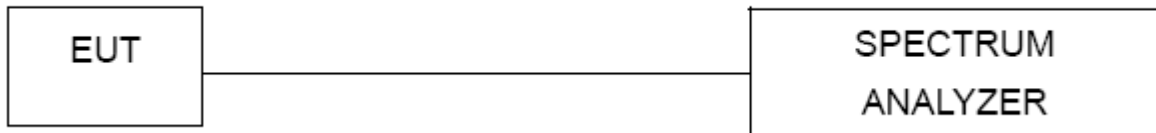

#### 4.4 TEST RESULTS

EUT :	Car MP3	Model Name :	DU7119
Temperature :	26 °C	Relative Humidity :	53%
Pressure :	1020 hPa	Test Power :	DC 12V
Test Mode :	TX		

Test Channel	Frequency (MHz)	20 dBc Bandwidth (KHz)	Limit (KHz)
Low	88.1	131.442	200
Mid	98.1	156.372	200
High	107.9	156.635	200

### The Lowest Channel: 88.1 MHz

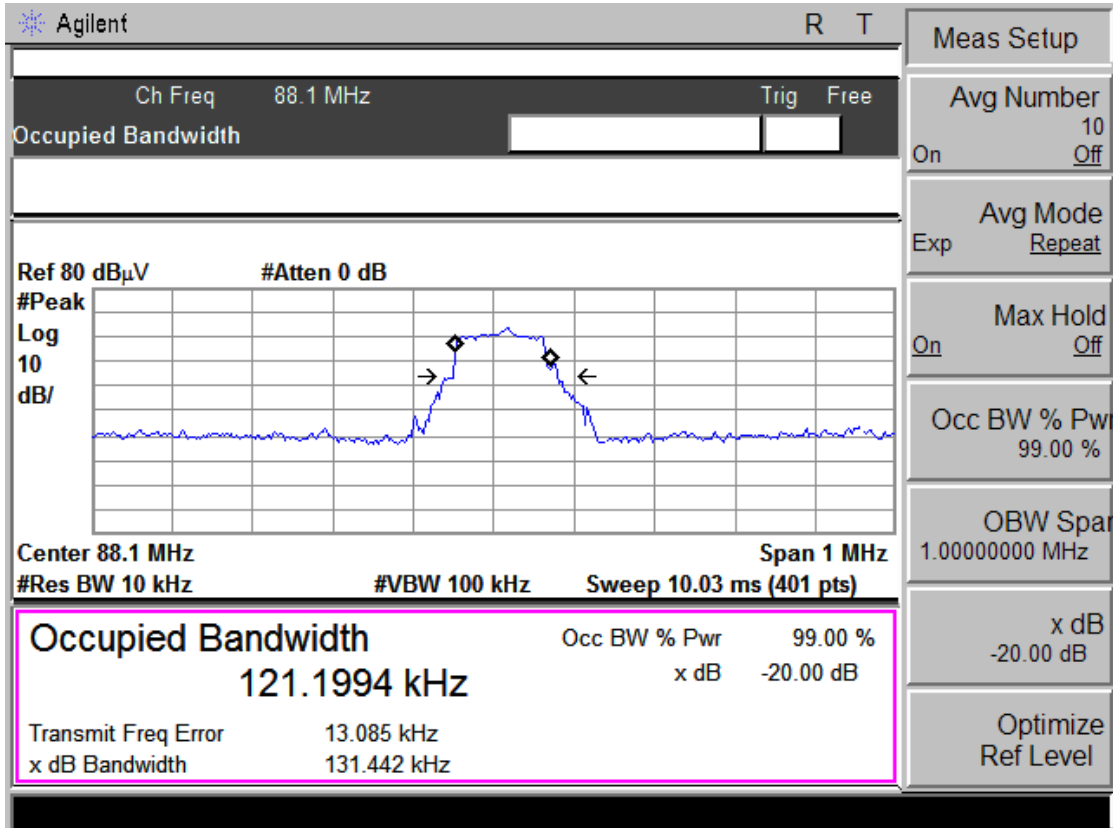

### The Middle Channel: 98.1 MHz

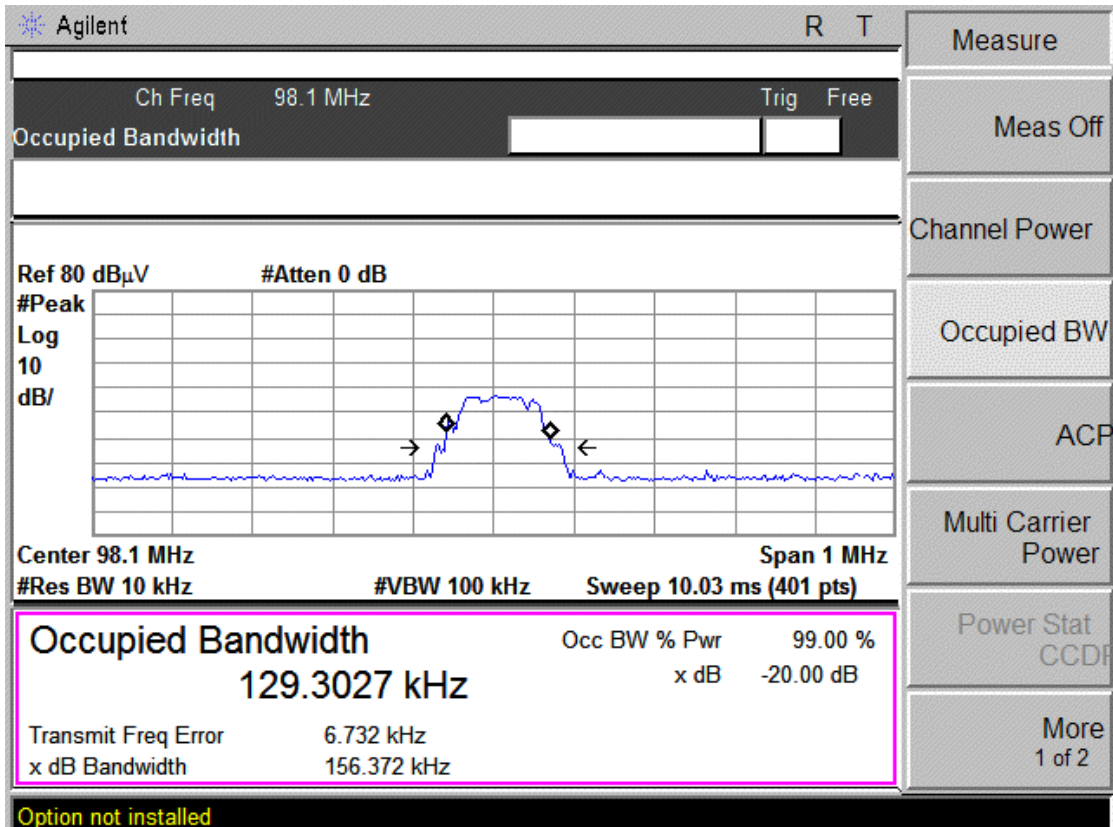

Option not installed

### The High Channel:107.9MHz

Agilent
R T

---

Ch Freq 107.9 MHz
Trig Free

Occupied Bandwidth

---

Ref 80 dB $\mu$ V
#Atten 0 dB

#Peak
Log

10
dB/

Center 107.9 MHz
Span 1 MHz

#Res BW 10 kHz
#VBW 100 kHz
Sweep 10.03 ms (401 pts)

<b>Occupied Bandwidth</b>	Occ BW % Pwr	99.00 %
125.8717 kHz	x dB	-20.00 dB
Transmit Freq Error	15.416 kHz	
x dB Bandwidth	156.635 kHz	

Option not installed

Measure

Meas Off

Channel Power

Occupied BW

ACP

Multi Carrier Power

Power Stat  
CCDF

More  
1 of 2

**5. EUT TEST PHOTO**

**Radiated Measurement Photos**

