

Test Report

FCC Part15 Subpart C

Product Name : Wi-Fi Module
Model No. : LW100
FCC ID : Y2SLW100
IC : 9452A-LW100

Applicant : LIBRATONE A/S

Address : Marielundvej 43A, DK-2730 Herlev, Denmark

Date of Receipt : Jun. 23, 2015

Test Date : Jun. 23, 2015~ Aug. 11, 2015

Issued Date : Aug. 11, 2015

Report No. : 1560632R-RF-US-P06V01

Report Version : V1.0

The test results relate only to the samples tested.

The test results shown in the test report are traceable to the national/international standard through the calibration of the equipment and evaluated measurement uncertainty herein.

This report must not be used to claim product endorsement by any agency of the government.

The test report shall not be reproduced without the written approval of QuieTek Corporation.

Test Report Certification

Issued Date : Aug. 11, 2015
Report No. : 1560632R-RF-US-P06V01

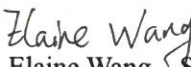

Product Name : Wi-Fi Module
Applicant : LIBRATONE A/S
Address : Marielundvej 43A, DK-2730 Herlev, Denmark
Manufacturer : Goertek Inc
Address : No 268 Dongfang Rd., New&high-tech Industry Development
Zone Weifang Shandong Province 261031, PRC.
Model No. : LW100
FCC ID : Y2SLW100
IC : 9452A-LW100
EUT Voltage : 3.8V DC
Brand Name : LIBRATONE
Applicable Standard : FCC CFR Title 47 Part 15 Subpart C: 2014
ANSI C63.4:2014;
ANSI C63.10:2013;
KDB 558074 D01v03r03
Industry Canada RSS-Gen Issue 4
Industry Canada RSS-247 Issue 1
Test Result : Complied
Performed Location : Suzhou EMC Laboratory
No.99 Hongye Rd., Suzhou Industrial Park Loufeng Hi-Tech
Development Zone., Suzhou, China
TEL: +86-512-6251-5088 / FAX: +86-512-6251-5098
FCC Registration Number: 800392; IC Lab Code: 4075B

Documented By : 
Elaine Wang Senior Engineer

Reviewed By : 
Harry Zhao RF Engineering Manager

Approved By : 
Dream Cao Director

Laboratory Information

We, **Quietek Corporation**, are an independent EMC and safety consultancy that was established the whole facility in our laboratories. The test facility has been accredited/accepted(audited or listed) by the following related bodies in compliance with ISO 17025, EN 45001 and specified testing scope:

Taiwan R.O.C.	:	BSMI, NCC
USA	:	FCC
Japan	:	VCCI
China	:	CNAS

The related certificate for our laboratories about the test site and management system can be downloaded from Quietek Corporation's Web Site :<http://www.quietek.com/tw/ctg/cts/accreditations.htm>

The address and introduction of Quietek Corporation's laboratories can be founded in our Web site :
<http://www.quietek.com/>

If you have any comments, Please don't hesitate to contact us. Our contact information is as below:

HsinChu Testing Laboratory :

No.75-2, 3rd Lin, Wangye Keng, Yonghxing Tsuen, Qionglin Shiang, Hsinchu County 307, Taiwan, R.O.C.
TEL:+886-3-592-8858 / FAX:+886-3-592-8859 E-Mail : service@quietek.com

LinKou Testing Laboratory :

No.5-22, Ruishukeng, Linkou Dist., New Taipei City 24451, Taiwan, R.O.C.
TEL : 886-2-8601-3788 / FAX : 886-2-8601-3789 E-Mail : service@quietek.com

Suzhou Testing Laboratory :

No.99 Hongye Rd., Suzhou Industrial Park Loufeng Hi-Tech Development Zone., SuZhou, China
TEL : +86-512-6251-5088 / FAX : 86-512-6251-5098 E-Mail : service@quietek.com

TABLE OF CONTENTS

Description	Page
1. General Information.....	7
1.1. EUT Description	7
1.2. Mode of Operation.....	12
2.1. Tested System Details	13
2.2. Configuration of Tested System.....	14
2.3. EUT Exercise Software.....	15
3. Technical Test.....	16
3.1. Summary of Test Result.....	16
3.2. Test Environment.....	18
4. Conducted Emission.....	19
4.1. Test Equipment.....	19
4.2. Test Setup.....	19
4.3. Limit.....	20
4.4. Test Procedure	20
4.5. Uncertainty	21
4.6. Test Result.....	22
5. Radiated Emission.....	24
5.1. Test Equipment.....	24
5.2. Test Setup.....	25
5.3. Limit.....	26
5.4. Test Procedure	26
5.5. Uncertainty	27
5.6. Test Result.....	28
6. RF Antenna Conducted Spurious	38
6.1. Test Equipment.....	38
6.2. Test Setup.....	38
6.3. Limit.....	38
6.4. Test Procedure	39
6.5. Uncertainty	39
6.6. Test Result.....	40
7. Radiated Emission Band Edge	72
7.1. Test Equipment.....	72
7.2. Test Setup.....	73
7.3. Limit.....	73
7.4. Test Procedure	73
7.5. Uncertainty	74
7.6. Test Result.....	75

8.	Occupied Bandwidth.....	139
8.1.	Test Equipment.....	139
8.2.	Test Setup.....	139
8.3.	Limit.....	139
8.4.	Test Procedure	139
8.5.	Uncertainty	140
8.6.	Test Result.....	141
9.	Power Output.....	157
9.1.	Test Equipment.....	157
9.2.	Test Setup.....	157
9.3.	Limit.....	157
9.4.	Test Procedure	158
9.5.	Uncertainty	158
9.6.	Test Result.....	159
10.	Power Spectral Density	164
10.1.	Test Equipment.....	164
10.2.	Test Setup.....	164
10.3.	Limit.....	164
10.4.	Test Procedure	165
10.5.	Uncertainty	165
10.6.	Test Result.....	166

History of This Test Report

REPORT NO.	VERSION	DESCRIPTION	ISSUED DATE
1560632R-RF-US-P06V01	V1.0	Initial Issued Report	Aug. 11, 2015

1. General Information

1.1. EUT Description

Product Name	Wi-Fi Module
Brand Name	LIBRATONE
Model No.	LW100
EUT Voltage	3.8V DC
Frequency Range	For 2.4GHz Band 802.11b/g/n(20MHz): 2412~2462MHz 802.11n(40MHz): 2422~2452MHz For 5GHz Band 802.11a/n(20MHz):5180~5240MHz, 5745~5825MHz 802.11n(40MHz):5190MHz, 5755~5795MHz
Channel Number	For 2.4GHz Band 802.11b/g/n(20MHz): 11 802.11n(40MHz): 9 For 5GHz Band 802.11a/n(20MHz): 9 802.11n(40MHz): 3
Type of Modulation	802.11b: DSSS 802.11a/g/n: OFDM
Data Rate	802.11a/g: 6/9/12/18/24/36/48/54 Mbps 802.11b: 1/2/5.5/11 Mbps 802.11n: up to 150 Mbps
Channel Control	Auto
Antenna Delivery	2*T _x + 2*R _x
Antenna Type	Reference to Antenna List
Peak Antenna Gain	Reference to Antenna List

For 2.4GHz Band

802.11b/g/n(20MHz) Working Frequency of Each Channel:							
Channel	Frequency	Channel	Frequency	Channel	Frequency	Channel	Frequency
01	2412 MHz	02	2417 MHz	03	2422 MHz	04	2427 MHz
05	2432 MHz	06	2437 MHz	07	2442 MHz	08	2447 MHz
09	2452 MHz	10	2457 MHz	11	2462 MHz	N/A	N/A
802.11n(40MHz) Working Frequency of Each Channel:							
Channel	Frequency	Channel	Frequency	Channel	Frequency	Channel	Frequency
03	2422 MHz	04	2427 MHz	05	2432 MHz	06	2437 MHz
07	2442 MHz	08	2447 MHz	09	2452 MHz	N/A	N/A

Antenna List

Antenna	Manufacturer	Model No.	Peak Gain
PIFA Antenna	Suzhou Walsin Technology Electronics Co.,Ltd	Z_2.4/5G_R_R4; Z_2.4/5G_L_R4	2.4GHz band: 3.5dBi 5GHz Band: 2dBi

. Power Parameter Value of the test software

Test Mode	Test Channel	Ant1	Ant2	MIMO MODE(Ant1+2)
802.11b	2412	7	7	x
	2437	18	18	x
	2462	9	9	x
802.11g	2412	12	12	x
	2437	16	16	x
	2462	13	13	x
802.11n(20MHz)	2412	12	12	x
	2437	15	15	x
	2462	13	13	x
802.11n(40MHz)	2422	13	13	x
	2437	13	13	x
	2452	13	13	x

The test mode of the test software can support.

Test Mode	Test Channel	Ant1	Ant2	MIMO MODE(Ant1+2)
802.11b	2412	√	√	×
	2437	√	√	×
	2462	√	√	×
802.11g	2412	√	√	×
	2437	√	√	×
	2462	√	√	×
802.11n(20MHz)	2412	√	√	×
	2437	√	√	×
	2462	√	√	×
802.11n(40MHz)	2422	√	√	×
	2437	√	√	×
	2452	√	√	×

Duty Cycle

2.4GHz Band

Test Mode	Duty Cycle
802.11b	99.4%
802.11g	98.1%
802.11n(20MHz)	97.6%
802.11n(40MHz)	96.7%

1.2. Mode of Operation

QuieTek has verified the construction and function in typical operation. All the test modes were carried out with the EUT in normal operation, which was shown in this test report and defined as:

Test Mode
Mode 1: Transmit by 802.11b
Mode 2: Transmit by 802.11g
Mode 3: Transmit by 802.11n(20MHz)
Mode 4: Transmit by 802.11n(40MHz)

Note:

1. Regards to the frequency band operation: the lowest, middle and highest frequency of channel were selected to perform the test, then shown on this report.
2. The radiation measurements are performed in X, Y, Z axis positioning. Only the worst case is shown in the report.

2.1. Tested System Details

The types for all equipments, plus descriptions of all cables used in the tested system (including inserted cards) are:

Product		Manufacturer	Model No.	Serial No.	Power Cord
1	Notebook	Asus	N80V	8BN0AS226971468	N/A

2.2. Configuration of Tested System

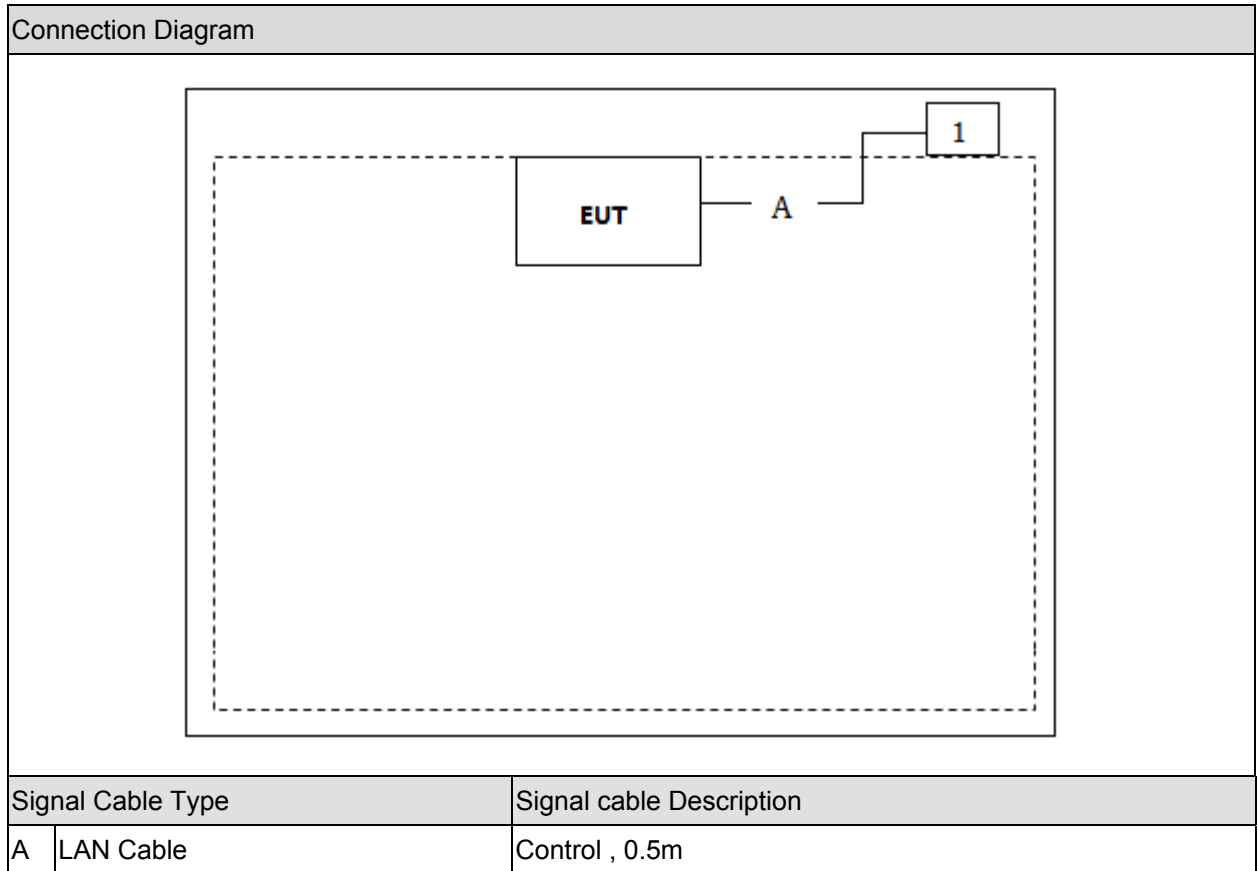

2.3. EUT Exercise Software

1	Setup the EUT and simulators as shown on above.
2	Turn on the power of equipment.
3	Input the RF commands, and set the test mode and channel, then press OK to start continue Transmit or receive.

3. Technical Test

3.1. Summary of Test Result

- No deviations from the test standards
 Deviations from the test standards as below description:

For FCC

Performed Test Item	Normative References	Test Performed	Deviation
Conducted Emission	FCC CFR Title 47 Part 15 Subpart C: 2015 Section 15.207	Yes	No
Radiated Emission	FCC CFR Title 47 Part 15 Subpart C: 2015 Section 15.209	Yes	No
RF Antenna Conducted Spurious	FCC CFR Title 47 Part 15 Subpart C: 2015 Section 15.247(d)	Yes	No
Radiated Emission Band Edge	FCC CFR Title 47 Part 15 Subpart C: 2015 15.247(d)	Yes	No
Operation Frequency Range of 20dB Bandwidth	FCC CFR Title 47 Part 15 Subpart C: 2015 15.215(c)	Yes	No
Occupied Bandwidth	FCC CFR Title 47 Part 15 Subpart C: 2015 Section 15.247(a)(2)	Yes	No
Power Output	FCC CFR Title 47 Part 15 Subpart C: 2015 Section 15.247(b)(3)	Yes	No
Power Spectral Density	FCC CFR Title 47 Part 15 Subpart C: 2015 Section 15.247(e)	Yes	No

For IC

Performed Test Item	Normative References	Test Performed	Deviation
Conducted Emission	RSS-Gen Issue 4 November 2014 Section 8.8	Yes	No
Radiated Emission	RSS-247 Issue 1 May 2015 Section 5.5	Yes	No
RF Antenna Conducted Spurious	RSS-247 Issue 1 May 2015 Section 5.5	Yes	No
Radiated Emission Band Edge	RSS-Gen Issue 4 November 2014 Section 8.10	Yes	No
Occupied Bandwidth	RSS-Gen Issue 4 November 2014 Section 6.6 RSS-247 Issue 1 May 2015 Section 5.2	Yes	No
Power Output	RSS-247 Issue 1 May 2015 Section 5.4	Yes	No
Power Spectral Density	RSS-247 Issue 1 May 2015 Section 5.2	Yes	No

3.2. Test Environment

Items	Required (IEC 68-1)	Actual
Temperature (°C)	15-35	21
Humidity (%RH)	25-75	50
Barometric pressure (mbar)	860-1060	950-1000

4. Conducted Emission

4.1. Test Equipment

Conducted Emission / TR-1

Instrument	Manufacturer	Type No.	Serial No.	Cal. Due Date
EMI Test Receiver	R&S	ESCI	100726	2016.03.28
Two-Line V-Network	R&S	ENV216	100043	2016.03.28
Two-Line V-Network	R&S	ENV216	100044	2015.09.16
50ohm Coaxial Switch	Anritsu	MP59B	6200464462	2016.03.01
50ohm Termination	SHX	TF2	07081401	2015.09.16
Temperature/Humidity Meter	zhicheng	ZC1-2	TR1-TH	2016.01.08

Note: All equipments are calibrated with traceable calibrations. Each calibration is traceable to the national or international standards.

4.2. Test Setup

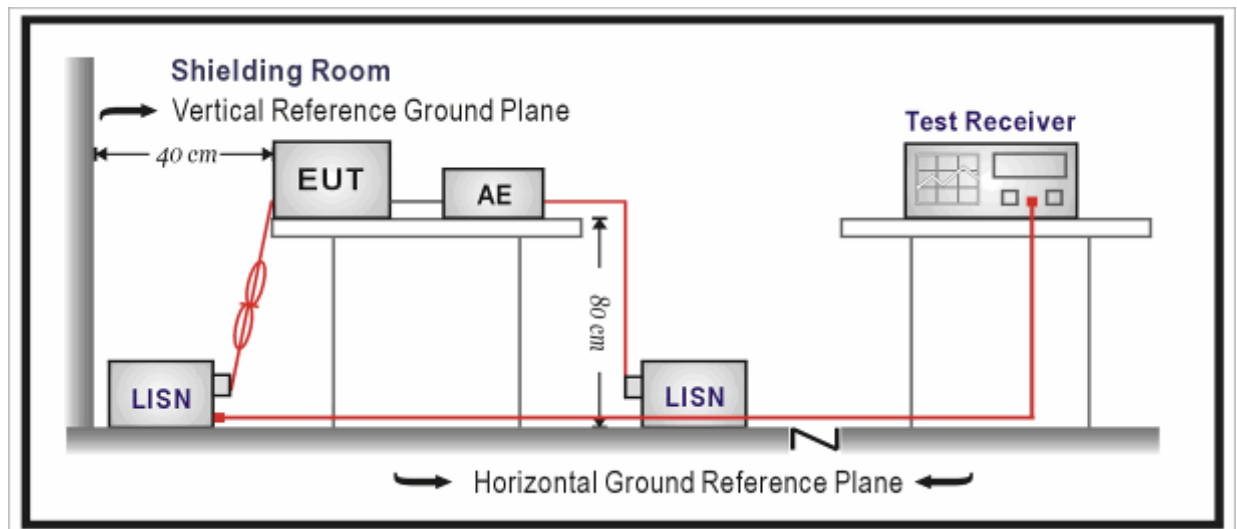

4.3. Limit

FCC Part 15 Subpart C Paragraph 15.207 Limits		
Frequency (MHz)	QP (dBuV)	AV (dBuV)
0.15 - 0.50	66 - 56	56 – 46
0.50 - 5.0	56	46
5.0 - 30	60	50

Note 1: The lower limit shall apply at the transition frequencies.

Note 2: The limit decreases linearly with the logarithm of the frequency in the range 0.15 MHz to 0.5 MHz.

4.4. Test Procedure

According to FCC ANSI C63.4: 2014 & ANSI C63.10: 2013& FCC 47CFR 15.247& KDB 558074 D01v03r03& Industry Canada RSS-Gen Issue 4& RSS-247 Issue 1

According to KDB 174176 D01 Line Conducted FAQ v01r01, it is required to perform the AC power-line conducted emissions testing and demonstrate compliance with the AC power-line emission requirements in Sections 15.107 or 15.207.

FCC&IC

The EUT was setup according to ANSI C63.4, 2014 for compliance to FCC 47CFR 15.247 requirements. The EUT was placed on a platform of nominal size, 1 m by 1.5 m, raised 80 cm above the conducting ground plane. The vertical conducting plane was located 40 cm to the rear of the EUT. All other surfaces of EUT were at least 80 cm from any other grounded conducting surface. The EUT and simulators are connected to the main power through a line impedance stabilization network (LISN). The LISN provides a 50 ohm /50uH coupling impedance for the measuring equipment. The peripheral devices are also connected to the main power through a LISN. (Please refer to the block diagram of the test setup and photographs) Each current-carrying conductor of the EUT power cord, except the ground (safety) conductor, was individually connected through a LISN to the input power source. The excess length of the power cord between the EUT and the LISN receptacle were folded back and forth at the center of the lead to form a bundle not exceeding 40 cm in length. Conducted emissions were investigated over the frequency range from 0.15MHz to 30MHz using a receiver bandwidth of 9 kHz.

4.5. Uncertainty

The measurement uncertainty is defined as ± 2.02 dB

4.6. Test Result

Engineer: Scott	
Site: TR5	Time: 2015/07/31 - 10:25
Limit: FCC_Part15.207_CE_AC Power_ClassB	Margin: 0
Probe: ENV216_101044(0.009-30MHz)	Polarity: Line
EUT: Wi-Fi Module	Power: AC 120V/60HZ
Note: Mode 1 802.11b CH2412	

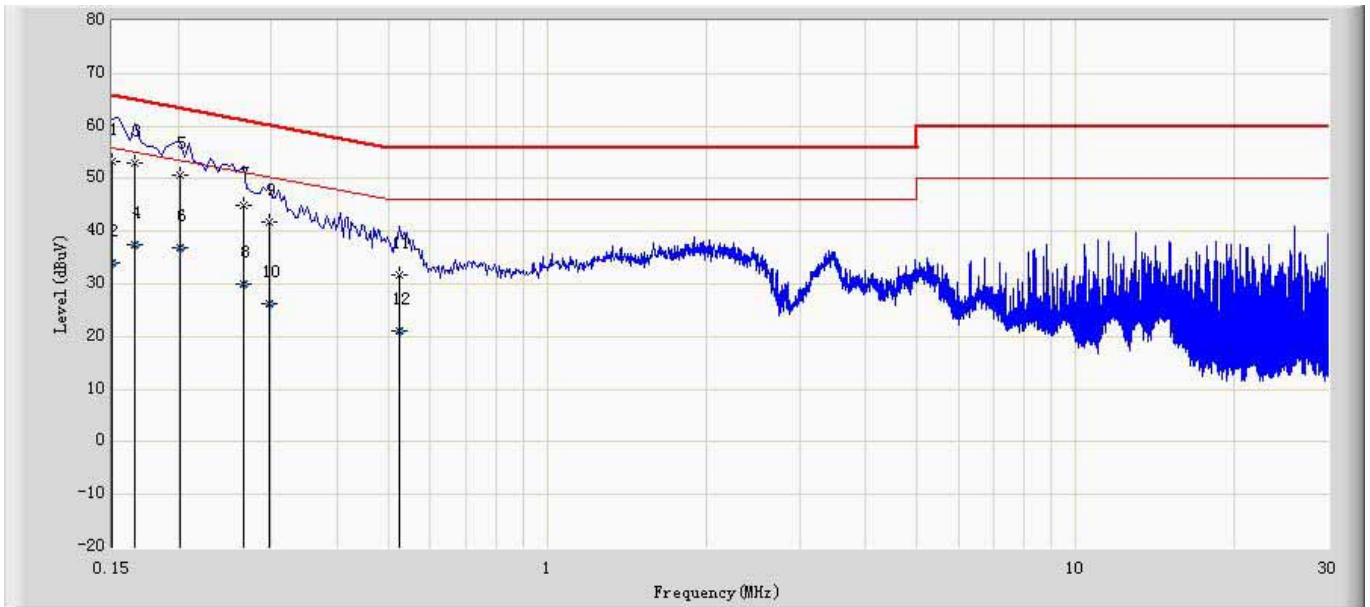

No	Mark	Frequency (MHz)	Measure Level (dBuV)	Reading Level (dBuV)	Over Limit (dB)	Limit (dBuV)	Factor (dB)	Type
1		0.150	53.278	43.430	-12.722	66.000	9.848	QP
2		0.150	33.958	24.110	-22.042	56.000	9.848	AV
3		0.166	53.112	43.263	-12.046	65.158	9.849	QP
4		0.166	37.528	27.679	-17.630	55.158	9.849	AV
5	*	0.202	50.797	40.937	-12.731	63.528	9.860	QP
6		0.202	36.968	27.108	-16.560	53.528	9.860	AV
7		0.266	44.887	35.018	-16.355	61.242	9.869	QP
8		0.266	30.049	20.180	-21.193	51.242	9.869	AV
9		0.298	41.706	31.833	-18.592	60.298	9.873	QP
10		0.298	26.238	16.365	-24.060	50.298	9.873	AV
11		0.526	31.715	21.814	-24.285	56.000	9.901	QP
12		0.526	21.200	11.299	-24.800	46.000	9.901	AV

Engineer: Scott	
Site: TR5	Time: 2015/07/31 - 10:31
Limit: FCC_Part15.207_CE_AC Power_ClassB	Margin: 0
Probe: ENV216_101044(0.009-30MHz)	Polarity: Neutral
EUT: Wi-Fi Module	Power: AC 120V/60Hz
Note: Mode 1 802.11b CH2412	

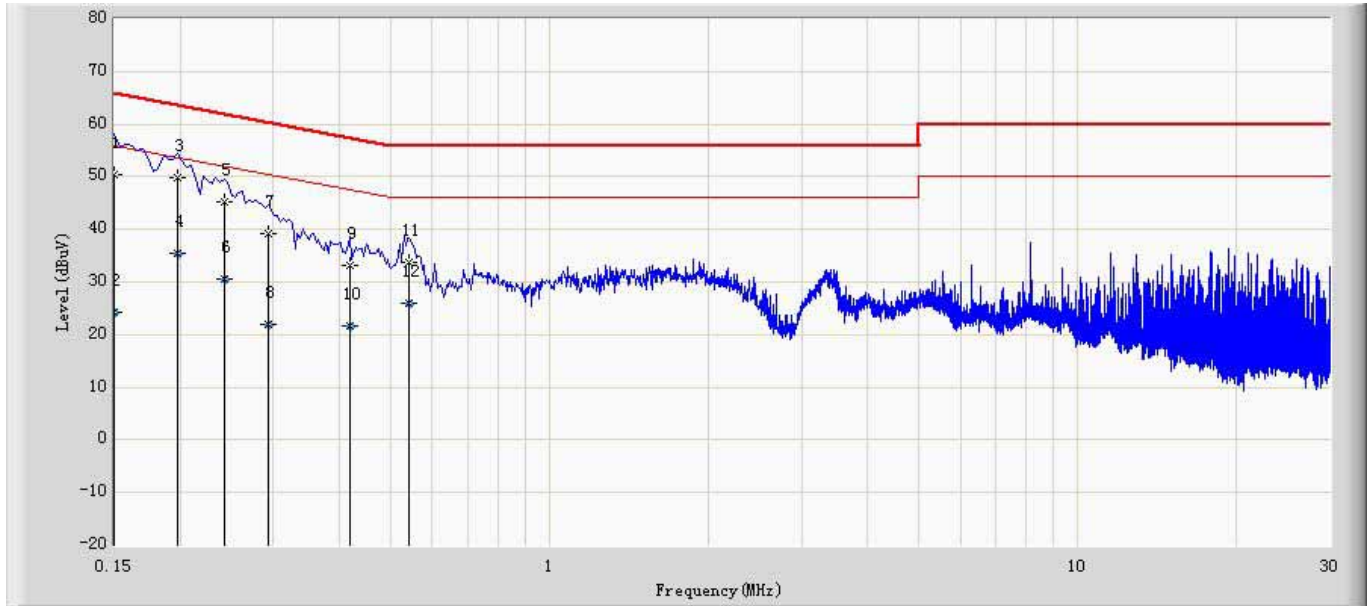

No	Mark	Frequency (MHz)	Measure Level (dBuV)	Reading Level (dBuV)	Over Limit (dB)	Limit (dBuV)	Factor (dB)	Type
1		0.150	50.462	40.487	-15.538	66.000	9.975	QP
2		0.150	24.208	14.233	-31.792	56.000	9.975	AV
3		0.198	49.960	40.038	-13.734	63.694	9.922	QP
4		0.198	35.381	25.459	-18.313	53.694	9.922	AV
5	*	0.242	45.350	35.429	-16.677	62.027	9.921	QP
6		0.242	30.495	20.574	-21.532	52.027	9.921	AV
7		0.294	39.277	29.330	-21.134	60.411	9.947	QP
8		0.294	22.014	12.067	-28.397	50.411	9.947	AV
9		0.418	33.068	23.049	-24.420	57.488	10.019	QP
10		0.418	21.711	11.692	-25.777	47.488	10.019	AV
11		0.542	33.864	23.842	-22.136	56.000	10.022	QP
12		0.542	26.033	16.011	-19.967	46.000	10.022	AV

Note: All the test modes are pretested and mode 1 802.11b mode was found to be the worst mode, so the data of this test mode was recorded.

5. Radiated Emission

5.1. Test Equipment

Radiated Emission / AC-2

Instrument	Manufacturer	Type No.	Serial No.	Cal. Due Date
EMI Test Receiver	R&S	ESCI	100573	2016.03.28
Loop Antenna	R&S	HFH2-Z2	833799/003	2015.11.17
Bilog Chainenna	Teseq GmbH	CBL6112D	27611	2015.10.15
Coaxial Cable	Huber+Suhner	SUCOFLEX 106	AC2-C	2016.03.01
Temperature/Humidity Meter	Zhicheng	ZC1-2	AC2-TH	2016.01.08

Radiated Emission / AC-5

Instrument	Manufacturer	Type No.	Serial No.	Cal. Due Date
Spectrum Analyzer	Agilent	N9020A	MY49100159	2016.03.28
Spectrum Analyzer	Agilent	E4446A	MY45300103	2016.01.07
Preamplifier	Miteq	NSP1800-25	1364185	2016.05.05
Preamplifier	Quietek	AP-040G	CHM-0906001	2016.05.05
DRG Horn	ETS-Lindgren	3117	00123988	2016.01.21
Broad-Band Horn Antenna	Schwarzbeck	BBHA9170	294	2015.11.24
Coaxial Cable	Huber+Suhner	SUCOFLEX 106	AC5-C1	2016.03.01
Coaxial Cable	Huber+Suhner	SUCOFLEX 106	AC5-C2	2016.03.01
Coaxial Cable	Huber+Suhner	SUCOFLEX 102	AC5-C3	2016.03.01
EMI Receiver	Agilent	N9038A	MY51210196	2016.06.09
Temperature/Humidity Meter	Zhichen	ZC1-2	AC5-TH	2016.01.08

Note 1: All equipments are calibrated with traceable calibrations. Each calibration is traceable to the national or international standards.

5.2. Test Setup

Below 30MHz Test Setup:

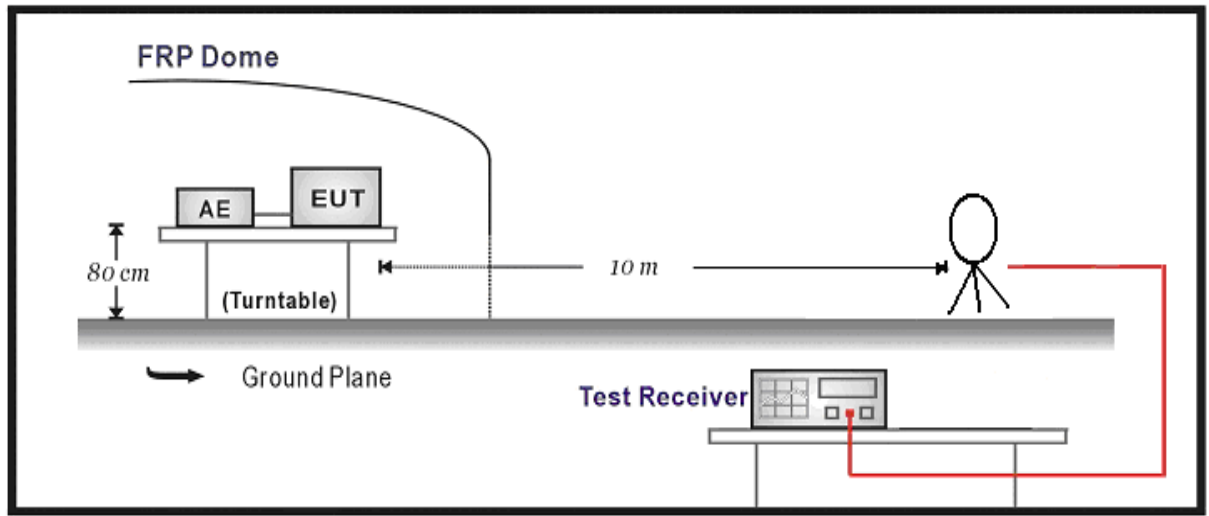

Below 1GHz Test Setup:

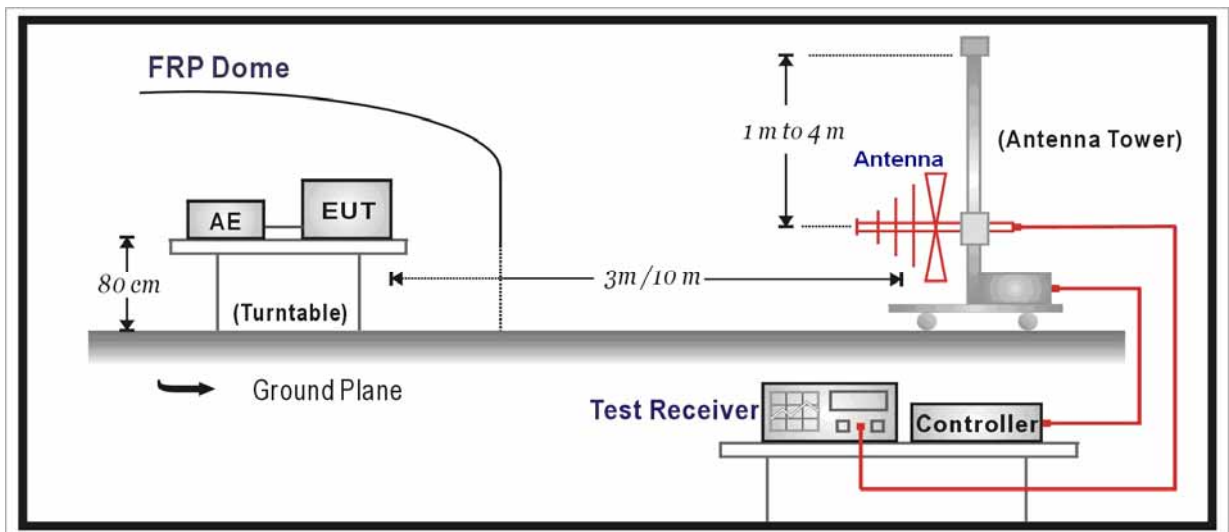

Above 1GHz Test Setup:

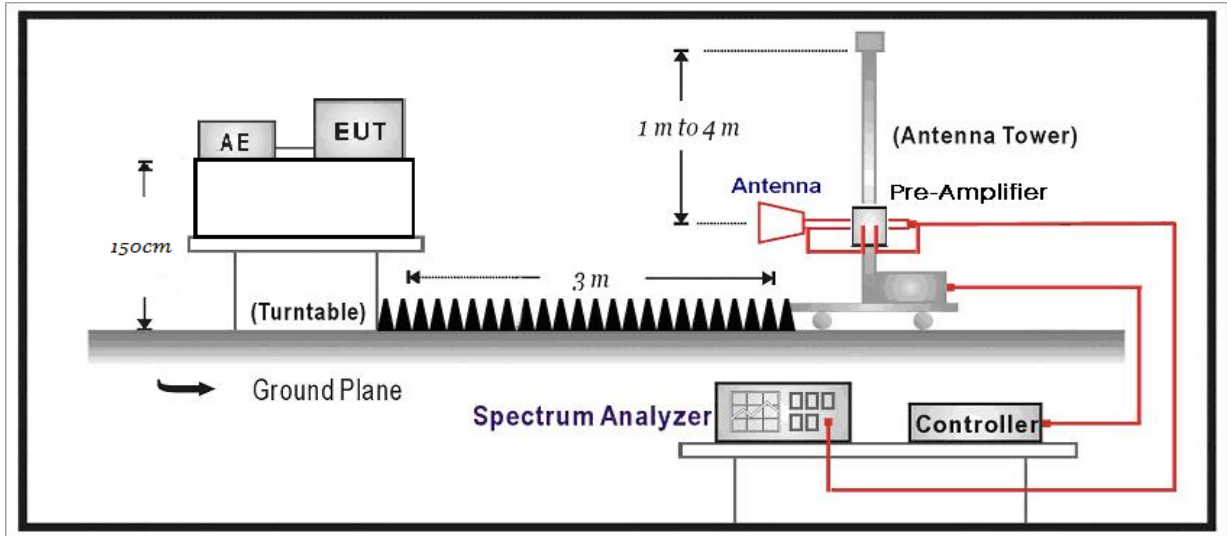

5.3. Limit

FCC Part 15 Subpart C Paragraph 15.209		
Frequency (MHz)	Distance (m)	Level (dBuV/m)
30 - 88	3	40
88 - 216	3	43.5
216 - 960	3	46
Above 960	3	54

Note 1: The lower limit shall apply at the transition frequency.

Note 2: Distance refers to the distance in meters between the measuring instrument Antenna and the closed point of any part of the device or system.

Note 3: E field strength (dBuV/m) = 20 log E field strength (uV/m)

5.4. Test Procedure

According to FCC ANSI C63.4: 2014 & ANSI C63.10: 2013& FCC 47CFR 15.247& KDB 558074 D01v03r03& ndustry Canada RSS-Gen Issue 4& RSS-247 Issue 1

FCC&IC

The EUT is placed on a turn table which is 1.5 meter above ground. The turn table is rotated 360 degrees to determine the position of the maximum emission level. The EUT was positioned such that the distance from Antenna to the EUT was 3 meters.

The antenna is scanned from 1 meter to 4 meters to find out the maximum emission level. This is repeated for both horizontal and vertical polarization of the Antenna. In order to find the maximum emission, all of the interface cables were manipulated according to ANSI C63.4:2014 on radiated measurement.

The resolution bandwidth below 1GHz setting on the field strength meter is 120 kHz and above 1GHz is 1MHz.

The frequency range from 30MHz to 10th harmonic is checked.

Note: When doing emission measurement above 1GHz, the horn Antenna will be bended down a little (as horn Antenna has the narrow beamwidth) in order to keeping the Antenna in the “cone of radiation” of EUT. The 3dB beamwidth is 10~60 degrees for H-plane and 10~90 degrees for E-plane.

5.5. Uncertainty

The measurement uncertainty above 1G is defined as ± 3.9 dB

below 1G is defined as ± 3.8 dB

5.6. Test Result

All of the test result shown indicates the worst case, and spectrum analyzer parameters setting as shown below:

Peak detector: RBW = 1MHz, VBW = 3MHz, sweep time = 200ms;

Average detector: RBW = 1MHz, VBW = 10Hz, sweep time = auto.

Mode1: Transmit by 802.11b-Ant0

CH	Antenna	Frequency (MHz)	Reading Level (dBuV/m)	Factor (dB)	Measure Level (dBuV/m)	Limit (dBuV/m)	Margin (dB)	Detector
1	H	4825.0	35.7	7.6	43.3	54(note3)	-10.7	PK
	V	4825.0	38.3	7.6	45.9	54(note3)	-8.1	PK
	H	7236.0	28.3	12.6	40.9	54(note3)	-13.1	PK
	V	7236.0	28.6	12.6	41.2	54(note3)	-12.8	PK
	H	9648.0	26.3	14.9	41.2	54(note3)	-12.8	PK
	V	9648.0	26.4	14.9	41.2	54(note3)	-12.8	PK
6	H	4876.0	36.8	7.7	44.5	54(note3)	-9.5	PK
	V	4876.0	39.1	7.7	46.8	54(note3)	-7.2	PK
	H	7311.0	28.4	12.4	40.8	54(note3)	-13.2	PK
	V	7311.0	28.4	12.4	40.8	54(note3)	-13.2	PK
	H	9748.0	26.7	14.9	41.6	54(note3)	-12.4	PK
	V	9748.0	26.7	14.9	41.6	54(note3)	-12.4	PK
11	H	4927.0	37.0	7.9	44.9	54(note3)	-9.1	PK
	V	4927.0	38.4	7.9	46.2	54(note3)	-7.8	PK
	H	7386.0	28.0	12.3	40.3	54(note3)	-13.7	PK
	V	7386.0	28.4	12.3	40.7	54(note3)	-13.3	PK
	H	9848.0	27.0	15.3	42.4	54(note3)	-11.6	PK
	V	9848.0	27.0	15.3	42.4	54(note3)	-11.6	PK

Note: 1. Measure Level = Reading Level + Factor.

2. The test frequency range, 9kHz~30MHz, 18GHz~25GHz, both of the worst case are at least 6dB below the limits, therefore no data appear in the report.

3. This limit applies for using average detector, if the test result on peak is lower than average limit, then average measurement needn't be performed.

Mode2: Transmit by 802.11g-Ant0

CH	Antenna	Frequency (MHz)	Reading Level (dBuV/m)	Factor (dB)	Measure Level (dBuV/m)	Limit (dBuV/m)	Margin (dB)	Detector
1	H	4825.0	43.4	7.6	51.0	54(note3)	-3.0	PK
	V	4825.0	46.7	7.6	54.3	74	-19.7	PK
	V	4825.16	35.2	7.6	42.8	54	-11.2	AV
	H	7236.0	28.0	12.6	40.6	54(note3)	-13.4	PK
	V	7236.0	28.4	12.6	41.0	54(note3)	-13.0	PK
	H	9648.0	26.4	14.9	41.3	54(note3)	-12.7	PK
	V	9648.0	26.4	14.9	41.3	54(note3)	-12.7	PK
6	H	4867.5	40.7	7.6	48.3	54(note3)	-5.7	PK
	V	4876.0	45.9	7.7	53.6	54(note3)	-0.4	PK
	H	7311.0	27.7	12.4	40.1	54(note3)	-13.9	PK
	V	7311.0	28.0	12.4	40.4	54(note3)	-13.6	PK
	H	9748.0	27.8	14.9	42.7	54(note3)	-11.3	PK
	V	9748.0	27.9	14.9	42.8	54(note3)	-11.2	PK
11	H	4924.0	37.3	7.9	45.2	54(note3)	-8.8	PK
	V	4924.0	39.6	7.9	47.5	54(note3)	-6.5	PK
	H	7386.0	28.5	12.3	40.8	54(note3)	-13.2	PK
	V	7386.0	29.6	12.3	41.9	54(note3)	-12.1	PK
	H	9848.0	27.4	15.3	42.7	54(note3)	-11.3	PK
	V	9848.0	27.7	15.3	43.0	54(note3)	-11.0	PK

Note: 1. Measure Level = Reading Level + Factor.

2. The test frequency range, 9kHz~30MHz, 18GHz~25GHz, both of the worst case are at least 6dB below the limits, therefore no data appear in the report.
3. This limit applies for using average detector, if the test result on peak is lower than average limit, then average measurement needn't be performed.

Mode3: Transmit by 802.11n(20MHz)-Ant0

CH	Antenna	Frequency (MHz)	Reading Level (dBuV/m)	Factor (dB)	Measure Level (dBuV/m)	Limit (dBuV/m)	Margin (dB)	Detector
1	H	4824.0	27.4	7.6	35.0	54	-19.1	AV
	H	4833.5	46.8	7.8	54.6	74	-19.4	PK
	V	4824.9	36.1	7.6	43.7	54	-10.3	AV
	V	4833.5	49.1	7.8	56.8	74	-17.2	PK
	H	7236.0	27.9	12.6	40.6	54(note3)	-13.4	PK
	V	7236.0	28.4	12.6	41.0	54(note3)	-13.0	PK
	H	9648.0	26.3	14.9	41.2	54(note3)	-12.8	PK
	V	9648.0	26.9	14.9	41.8	54(note3)	-12.2	PK
6	H	4873.9	43.1	7.7	50.8	54	-3.2	AV
	H	4876.0	49.1	7.7	56.8	74	-17.2	PK
	V	4873.9	39.6	7.7	47.3	54	-6.7	AV
	V	4876.0	52.7	7.7	60.4	74	-13.6	PK
	H	7311.0	28.0	12.4	40.4	54(note3)	-13.6	PK
	V	7311.0	28.5	12.4	40.9	54(note3)	-13.1	PK
	H	9748.0	27.2	14.9	42.1	54(note3)	-11.9	PK
	V	9748.0	28.7	14.9	43.6	54(note3)	-10.4	PK
11	H	4917.6	36.0	7.9	43.9	54	-10.1	AV
	H	4918.5	49.2	7.9	57.1	74	-16.9	PK
	V	4917.7	36.6	7.9	44.4	54	-9.6	AV
	V	4918.5	49.2	7.9	57.1	74	-16.9	PK
	H	7386.0	28.0	12.3	40.3	54(note3)	-13.7	PK
	V	7386.0	28.1	12.3	40.4	54(note3)	-13.6	PK
	H	9848.0	26.8	15.3	42.1	54(note3)	-11.9	PK
	V	9848.0	27.5	15.3	42.8	54(note3)	-11.2	PK

Note: 1. Measure Level = Reading Level + Factor.

2. The test frequency range, 9kHz~30MHz, 18GHz~25GHz, both of the worst case are at least 6dB below the limits, therefore no data appear in the report.
3. This limit applies for using average detector, if the test result on peak is lower than average limit, then average measurement needn't be performed.

Mode4: Transmit by 802.11n(40MHz)-Ant0

CH	Antenna	Frequency (MHz)	Reading Level (dBuV/m)	Factor (dB)	Measure Level (dBuV/m)	Limit (dBuV/m)	Margin (dB)	Detector
3	H	4842.0	43.4	7.9	51.3	54(note3)	-2.7	PK
	V	4833.5	45.4	7.8	53.1	54(note3)	-0.9	PK
	H	7266.0	29.2	12.4	41.6	54(note3)	-12.4	PK
	V	7266.0	29.2	12.4	41.6	54(note3)	-12.4	PK
	H	9688.0	26.3	14.7	41.0	54(note3)	-13.0	PK
	V	9688.0	26.3	14.7	41.0	54(note3)	-13.0	PK
6	H	4876.0	41.6	7.7	49.3	54(note3)	-4.7	PK
	V	4867.5	44.6	7.6	52.3	54(note3)	-1.7	PK
	H	7311.0	27.7	12.4	40.1	54(note3)	-13.9	PK
	V	7311.0	28.0	12.4	40.5	54(note3)	-13.5	PK
	H	9748.0	27.8	14.9	42.7	54(note3)	-11.3	PK
	V	9748.0	27.8	14.9	42.7	54(note3)	-11.3	PK
9	H	4910.0	41.1	7.9	49.0	54(note3)	-5.0	PK
	V	4893.0	42.1	8.0	50.1	54(note3)	-3.9	PK
	H	7536.0	28.0	13.2	41.2	54(note3)	-12.8	PK
	V	7356.0	28.4	13.0	41.4	54(note3)	-12.6	PK
	H	9808.0	26.8	15.0	41.9	54(note3)	-12.1	PK
	V	9808.0	26.8	15.0	41.9	54(note3)	-12.1	PK

Note: 1. Measure Level = Reading Level + Factor.

2. The test frequency range, 9kHz~30MHz, 18GHz~25GHz, both of the worst case are at least 6dB below the limits, therefore no data appear in the report.
3. This limit applies for using average detector, if the test result on peak is lower than average limit, then average measurement needn't be performed.

Mode1: Transmit by 802.11b-Ant1

CH	Antenna	Frequency (MHz)	Reading Level (dBuV/m)	Factor (dB)	Measure Level (dBuV/m)	Limit (dBuV/m)	Margin (dB)	Detector
1	H	4824.0	35.5	7.6	43.1	54(note3)	-10.9	PK
	V	4824.0	38.8	7.6	46.4	54(note3)	-7.6	PK
	H	7236.0	28.8	12.6	41.4	54(note3)	-12.6	PK
	V	7236.0	29.1	12.6	41.7	54(note3)	-12.3	PK
	H	9648.0	26.4	14.9	41.3	54(note3)	-12.7	PK
	V	9648.0	27.0	14.9	41.9	54(note3)	-12.1	PK
6	H	4874.0	37.4	7.7	45.1	54(note3)	-8.9	PK
	V	4874.0	39.6	7.7	47.3	54(note3)	-6.7	PK
	H	7311.0	28.8	12.4	41.2	54(note3)	-12.8	PK
	V	7311.0	28.6	12.4	41.0	54(note3)	-13.0	PK
	H	9748.0	26.5	14.9	41.4	54(note3)	-12.6	PK
	V	9748.0	26.7	14.9	41.6	54(note3)	-12.4	PK
11	H	4924.0	36.8	7.9	44.7	54(note3)	-9.3	PK
	V	4924.0	38.1	7.9	46.0	54(note3)	-8.0	PK
	H	7386.0	27.8	12.3	40.1	54(note3)	-13.9	PK
	V	7386.0	29.0	12.3	41.3	54(note3)	-12.7	PK
	H	9848.0	27.1	15.3	42.4	54(note3)	-11.6	PK
	V	9848.0	27.0	15.3	42.3	54(note3)	-11.7	PK

Note: 1. Measure Level = Reading Level + Factor.

2. The test frequency range, 9kHz~30MHz, 18GHz~25GHz, both of the worst case are at least 6dB below the limits, therefore no data appear in the report.
3. This limit applies for using average detector, if the test result on peak is lower than average limit, then average measurement needn't be performed.

Mode2: Transmit by 802.11g-Ant1

CH	Antenna	Frequency (MHz)	Reading Level (dBuV/m)	Factor (dB)	Measure Level (dBuV/m)	Limit (dBuV/m)	Margin (dB)	Detector
1	H	4824.0	43.5	7.6	51.1	54(note3)	-2.9	PK
	V	4824.0	44.5	7.6	52.1	54(note3)	-1.9	PK
	H	7236.0	28.5	12.6	41.1	54(note3)	-12.9	PK
	V	7236.0	28.8	12.6	41.4	54(note3)	-12.6	PK
	H	9648.0	26.7	14.9	41.6	54(note3)	-12.4	PK
	V	9648.0	26.2	14.9	41.1	54(note3)	-12.9	PK
6	H	4874.0	40.5	7.6	48.1	54(note3)	-5.9	PK
	V	4874.0	45.7	7.7	53.4	54(note3)	-0.6	PK
	H	7311.0	28.4	12.4	40.8	54(note3)	-13.2	PK
	V	7311.0	28.2	12.4	40.6	54(note3)	-13.4	PK
	H	9748.0	27.5	14.9	42.4	54(note3)	-11.6	PK
	V	9748.0	27.7	14.9	42.6	54(note3)	-11.4	PK
11	H	4924.0	37.1	7.9	45.0	54(note3)	-9.0	PK
	V	4924.0	39.2	7.9	47.1	54(note3)	-6.9	PK
	H	7386.0	28.3	12.3	40.6	54(note3)	-13.4	PK
	V	7386.0	29.5	12.3	41.8	54(note3)	-12.2	PK
	H	9848.0	28.1	15.3	43.4	54(note3)	-10.6	PK
	V	9848.0	28.3	15.3	43.6	54(note3)	-10.4	PK

Note: 1. Measure Level = Reading Level + Factor.

2. The test frequency range, 9kHz~30MHz, 18GHz~25GHz, both of the worst case are at least 6dB below the limits, therefore no data appear in the report.
3. This limit applies for using average detector, if the test result on peak is lower than average limit, then average measurement needn't be performed.

Mode3: Transmit by 802.11n(20MHz)-Ant1

CH	Antenna	Frequency (MHz)	Reading Level (dBuV/m)	Factor (dB)	Measure Level (dBuV/m)	Limit (dBuV/m)	Margin (dB)	Detector
1	H	4824.0	40.1	7.8	47.9	54(note3)	-6.1	PK
	V	4824.0	41.7	7.8	49.5	54(note3)	-4.5	PK
	H	7236.0	28.1	12.6	40.7	54(note3)	-13.3	PK
	V	7236.0	28.7	12.6	41.3	54(note3)	-12.7	PK
	H	9648.0	26.7	14.9	41.6	54(note3)	-12.4	PK
	V	9648.0	27.5	14.9	42.4	54(note3)	-11.6	PK
6	H	4874.0	38.8	7.7	46.5	54(note3)	-7.5	PK
	V	4874.0	42.5	7.7	50.2	54(note3)	-3.8	PK
	H	7311.0	28.0	12.4	40.4	54(note3)	-13.6	PK
	V	7311.0	29.0	12.4	41.4	54(note3)	-12.6	PK
	H	9748.0	27.2	14.9	42.1	54(note3)	-11.9	PK
	V	9748.0	28.6	14.9	43.5	54(note3)	-10.5	PK
11	H	4924.0	39.6	7.9	47.5	54(note3)	-6.5	PK
	V	4924.0	39.2	7.9	47.1	54(note3)	-6.9	PK
	H	7386.0	28.2	12.3	40.5	54(note3)	-13.5	PK
	V	7386.0	28.6	12.3	40.9	54(note3)	-13.1	PK
	H	9848.0	27.2	15.3	42.5	54(note3)	-11.5	PK
	V	9848.0	27.7	15.3	43.0	54(note3)	-11.0	PK

Note: 1. Measure Level = Reading Level + Factor.

2. The test frequency range, 9kHz~30MHz, 18GHz~25GHz, both of the worst case are at least 6dB below the limits, therefore no data appear in the report.
3. This limit applies for using average detector, if the test result on peak is lower than average limit, then average measurement needn't be performed.

Mode4: Transmit by 802.11n(40MHz)-Ant1

CH	Antenna	Frequency (MHz)	Reading Level (dBuV/m)	Factor (dB)	Measure Level (dBuV/m)	Limit (dBuV/m)	Margin (dB)	Detector
3	H	4842.0	43.9	7.9	51.8	54(note3)	-2.2	PK
	V	4833.5	44.7	7.8	52.5	54(note3)	-1.5	PK
	H	7266.0	29.1	12.4	41.5	54(note3)	-12.5	PK
	V	7266.0	29.5	12.4	41.9	54(note3)	-12.1	PK
	H	9688.0	26.4	14.7	41.1	54(note3)	-12.9	PK
	V	9688.0	26.5	14.7	41.2	54(note3)	-12.8	PK
6	H	4876.0	42.0	7.7	49.7	54(note3)	-4.3	PK
	V	4867.5	44.2	7.6	51.8	54(note3)	-2.2	PK
	H	7311.0	27.4	12.4	39.8	54(note3)	-14.2	PK
	V	7311.0	28.2	12.4	40.6	54(note3)	-13.4	PK
	H	9748.0	28.4	14.9	43.3	54(note3)	-10.7	PK
	V	9748.0	27.7	14.9	42.6	54(note3)	-11.4	PK
9	H	4910.0	41.4	7.9	49.3	54(note3)	-4.7	PK
	V	4893.0	42.1	8.0	50.1	54(note3)	-3.9	PK
	H	7536.0	28.6	13.2	41.8	54(note3)	-12.2	PK
	V	7356.0	28.3	13.0	41.3	54(note3)	-12.7	PK
	H	9808.0	26.7	15.0	41.7	54(note3)	-12.3	PK
	V	9808.0	26.6	15.0	41.6	54(note3)	-12.4	PK

Note: 1. Measure Level = Reading Level + Factor.

2. The test frequency range, 9kHz~30MHz, 18GHz~25GHz, both of the worst case are at least 6dB below the limits, therefore no data appear in the report.
3. This limit applies for using average detector, if the test result on peak is lower than average limit, then average measurement needn't be performed.

The worst case of Radiated Emission below 1GHz:

Engineer: Scott	
Site: AC2	Time: 2015/07/31 - 09:57
Limit: FCC_Part15.209_RE(3m)_ClassB	Margin: 0
Probe: AC2_10M(30-1000M)20150408	Polarity: Horizontal
EUT: Wi-Fi Module	Power: AC 120V/60Hz
Note: Mode 1	

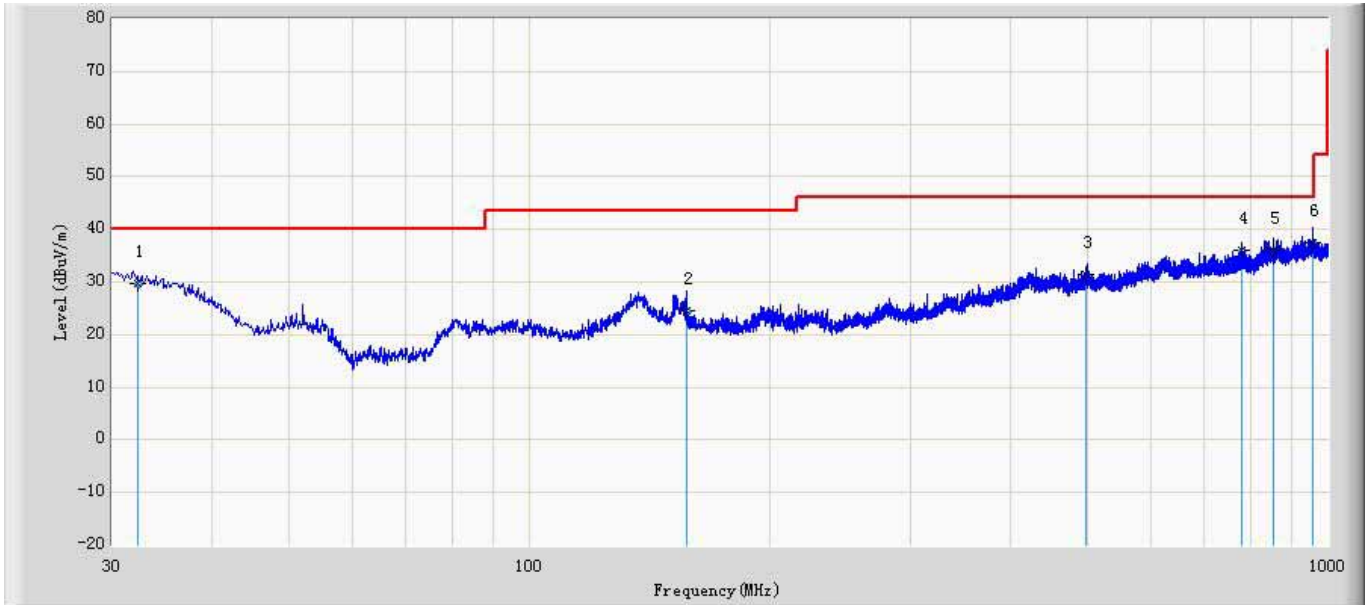

No	Mark	Frequency (MHz)	Measure Level (dBuV/m)	Reading Level (dBuV)	Over Limit (dB)	Limit (dBuV/m)	Factor (dB)	Type
1		32.250	29.781	34.786	-10.219	40.000	-5.005	QP
2		157.250	24.584	36.179	-18.916	43.500	-11.595	QP
3		498.250	31.366	33.934	-14.634	46.000	-2.568	QP
4	*	781.250	35.903	35.338	-10.097	46.000	0.565	QP
5		855.260	35.951	34.868	-10.049	46.000	1.083	QP
6		955.260	37.578	35.526	-8.422	46.000	2.052	QP

Engineer: Scott	
Site: AC2	Time: 2015/07/31 - 09:57
Limit: FCC_Part15.209_RE(3m)_ClassB	Margin: 0
Probe: AC2_10M(30-1000M)20150408	Polarity: Vertical
EUT: Wi-Fi Module	Power: AC 120V/60Hz
Note: Mode 1	

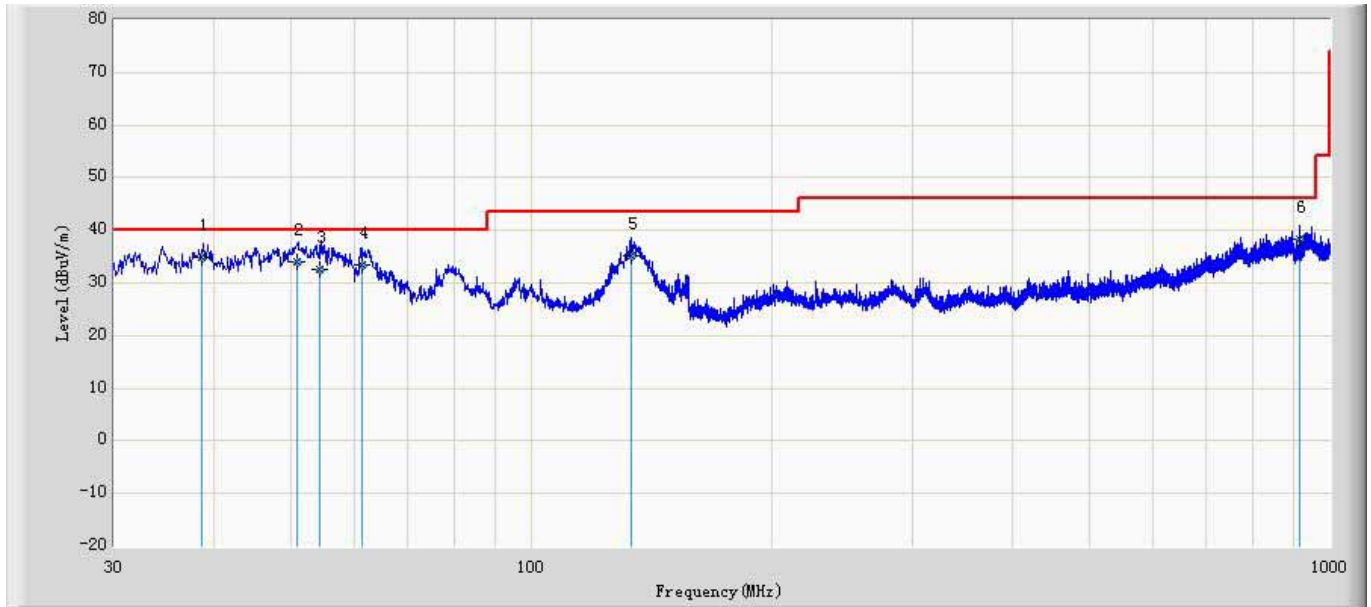

No	Mark	Frequency (MHz)	Measure Level (dBuV/m)	Reading Level (dBuV)	Over Limit (dB)	Limit (dBuV/m)	Factor (dB)	Type
1	*	38.650	34.903	43.670	-5.097	40.000	-8.767	QP
2		50.926	34.067	48.277	-5.933	40.000	-14.210	QP
3		54.250	32.466	47.208	-7.534	40.000	-14.742	QP
4		61.250	33.576	49.299	-6.424	40.000	-15.723	QP
5		133.250	35.051	45.221	-8.449	43.500	-10.170	QP
6		917.250	38.466	37.121	-7.534	46.000	1.345	QP

6. RF Antenna Conducted Spurious

6.1. Test Equipment

RF Antenna Conducted Spurious / TR-8

Instrument	Manufacturer	Type No.	Serial No.	Cal. Due Date
Spectrum Analyzer	Agilent	N9010A	MY48030494	2016.03.10
Temperature/Humidity Meter	zhicheng	ZC1-2	TR8-TH	2016.04.09

Note: All equipments are calibrated with traceable calibrations. Each calibration is traceable to the national or international standards.

6.2. Test Setup

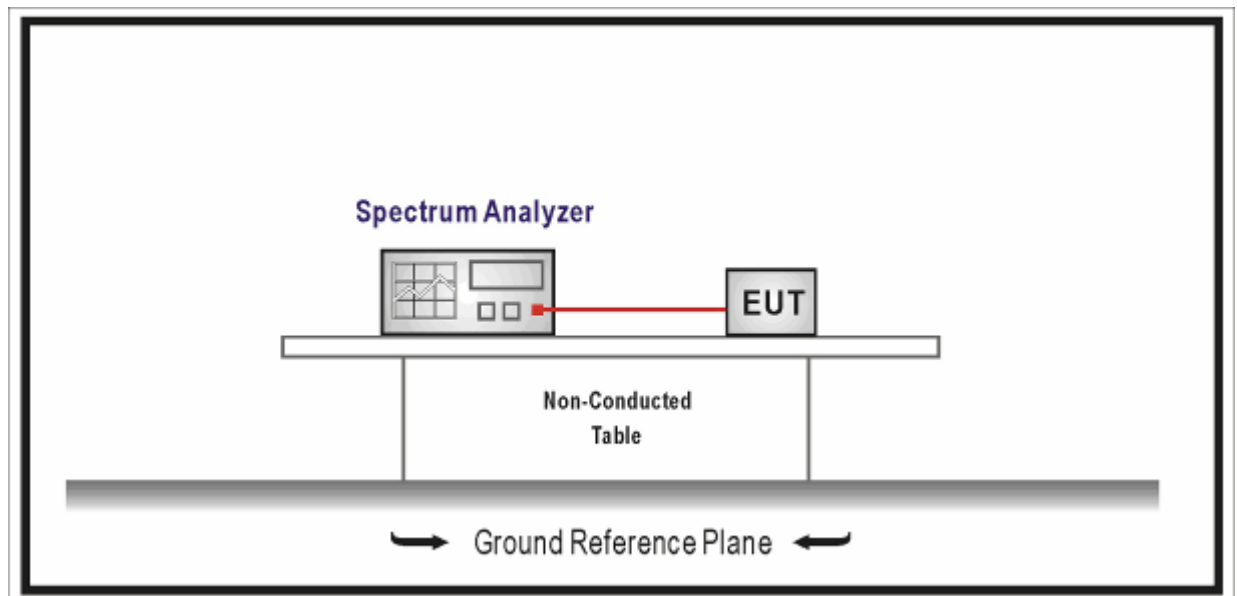

6.3. Limit

FCC&IC

In any 100 kHz bandwidth outside the frequency band in which the spread spectrum intentional radiator is operating, the radio frequency power that is produced by the intentional radiator shall be at least 20 dB below that in the 100 kHz bandwidth within the band that contains the highest level of the desired power, based on either an RF conducted or a radiated measurement.

6.4. Test Procedure

According to FCC ANSI C63.4: 2014 & ANSI C63.10: 2013& FCC 47CFR 15.247& KDB 558074 D01v03r03& Industry Canada RSS-Gen Issue 4& RSS-247 Issue 1

Set RBW = 100 kHz, Set VBW > RBW, scan up through 10th harmonic.

6.5. Uncertainty

The measurement uncertainty is defined as ± 1.27 dB

6.6. Test Result

Product	: Wi-Fi Module
Test Item	: RF Antenna Conducted Spurious
Test Site	: TR-8
Test Mode	: Mode 1: Transmit by 802.11b

Channel 01 (2412MHz)-Ant 0
 Reference Level – Frequency L



Low Band Edge - Frequency L



Spurious Emission 30MHz ~ 25GHz - Frequency L



Channel 06 (2437MHz)-Ant 0
Reference Level – Frequency M



Spurious Emission 30MHz ~ 25GHz - Frequency M



Channel 11 (2462MHz)-Ant 0
 Reference Level – Frequency H



High Band Edge - Frequency H

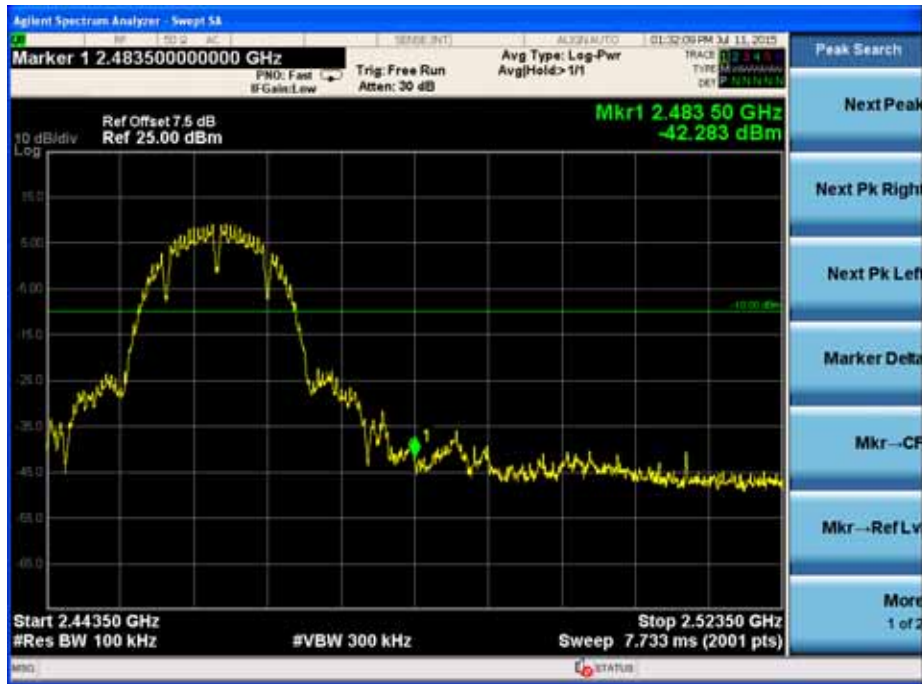

Spurious Emission 30MHz ~ 25GHz - Frequency H



Channel 01 (2412MHz)-Ant 1
 Reference Level – Frequency L



Low Band Edge - Frequency L



Spurious Emission 30MHz ~ 25GHz - Frequency L



Channel 06 (2437MHz)-Ant 1
 Reference Level – Frequency M



Spurious Emission 30MHz ~ 25GHz - Frequency M



Channel 11 (2462MHz)-Ant 1
Reference Level – Frequency H



High Band Edge - Frequency H

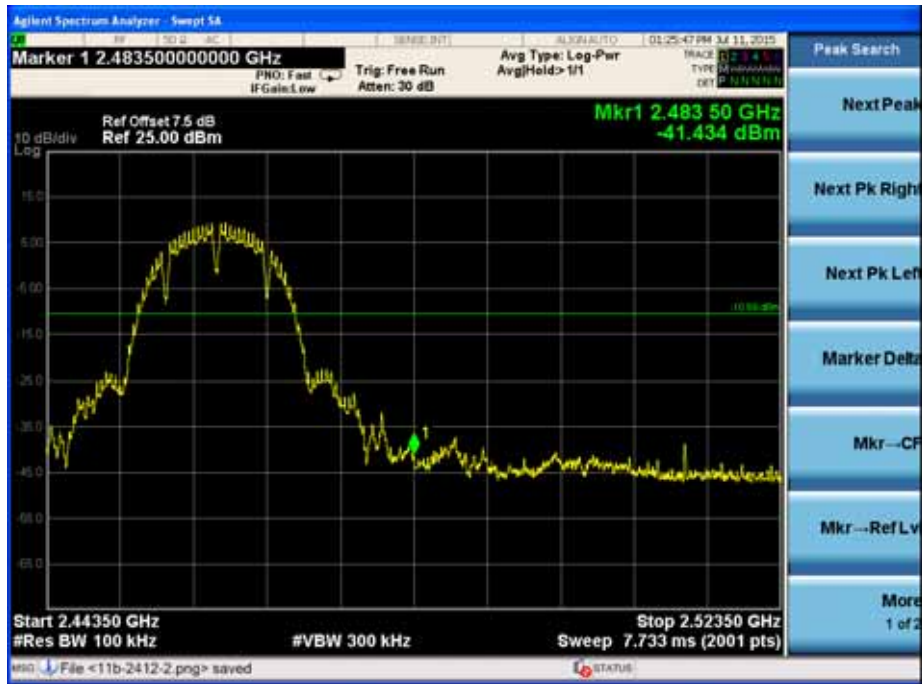

Spurious Emission 30MHz ~ 25GHz - Frequency H



Product	: Wi-Fi Module
Test Item	: RF Antenna Conducted Spurious
Test Site	: TR-8
Test Mode	: Mode 2: Transmit by 802.11g

Channel 01 (2412MHz)-Ant 0
Reference Level – Frequency L



Low Band Edge - Frequency L

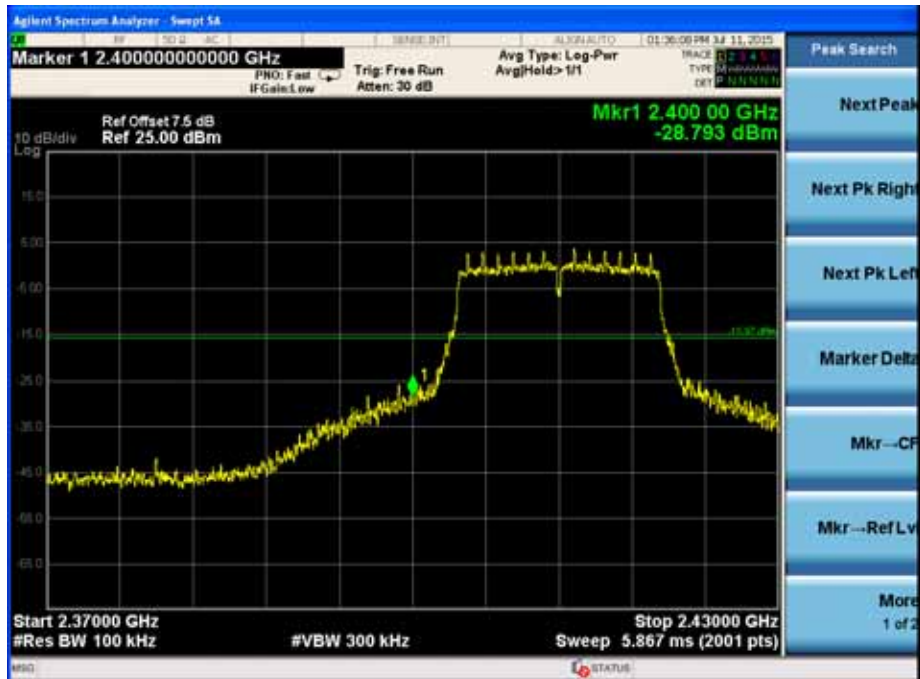

Spurious Emission 30MHz ~ 25GHz - Frequency L



Channel 06 (2437MHz)-Ant 0
Reference Level – Frequency M



Spurious Emission 30MHz ~ 25GHz - Frequency M

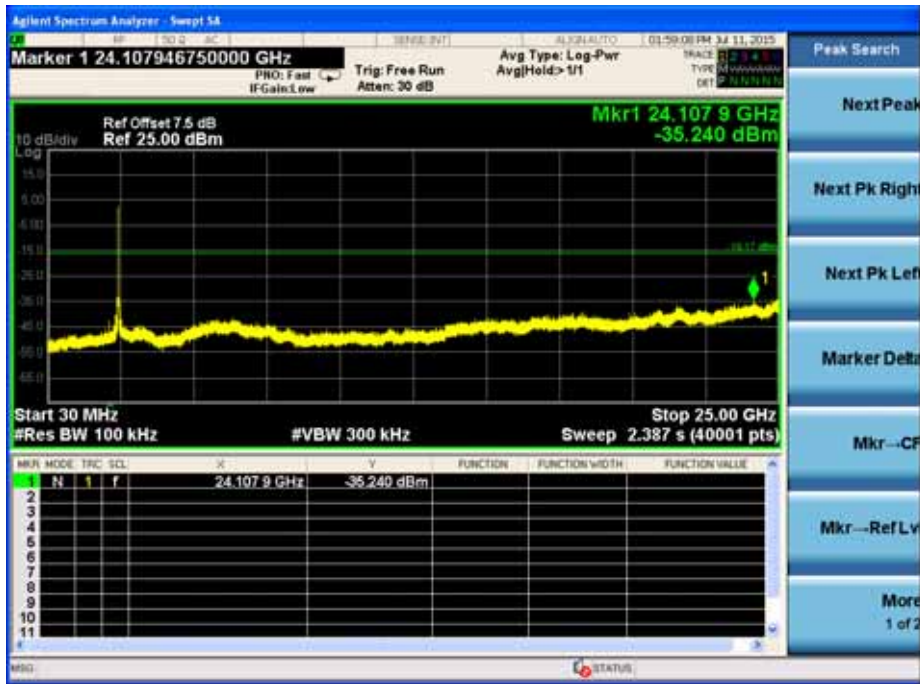

Channel 11 (2462MHz)-Ant 0
 Reference Level – Frequency H



High Band Edge - Frequency H

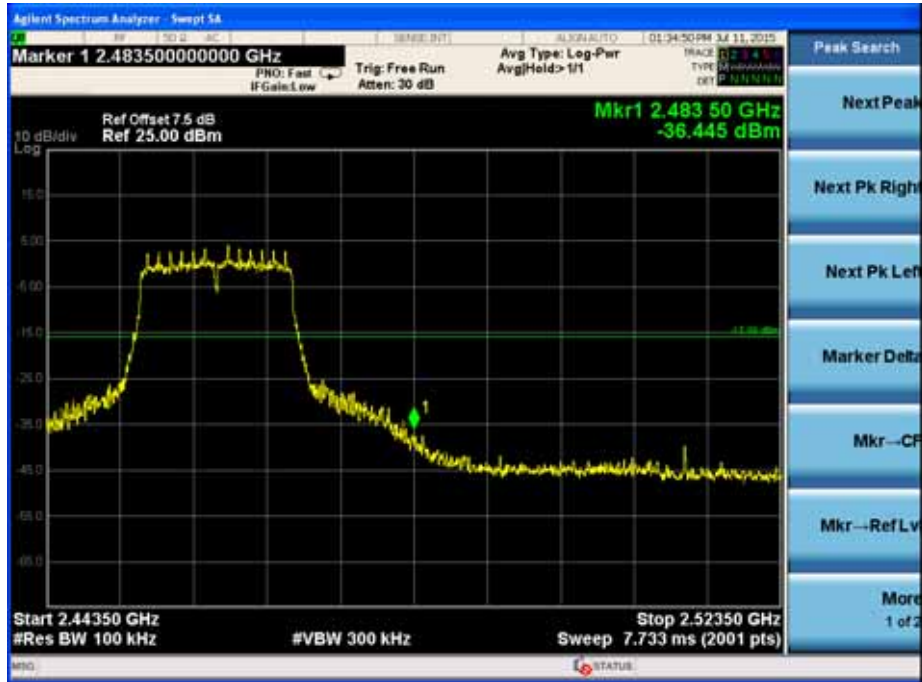

Spurious Emission 30MHz ~ 25GHz - Frequency H



Channel 01 (2412MHz) –Ant 1 Reference Level – Frequency L

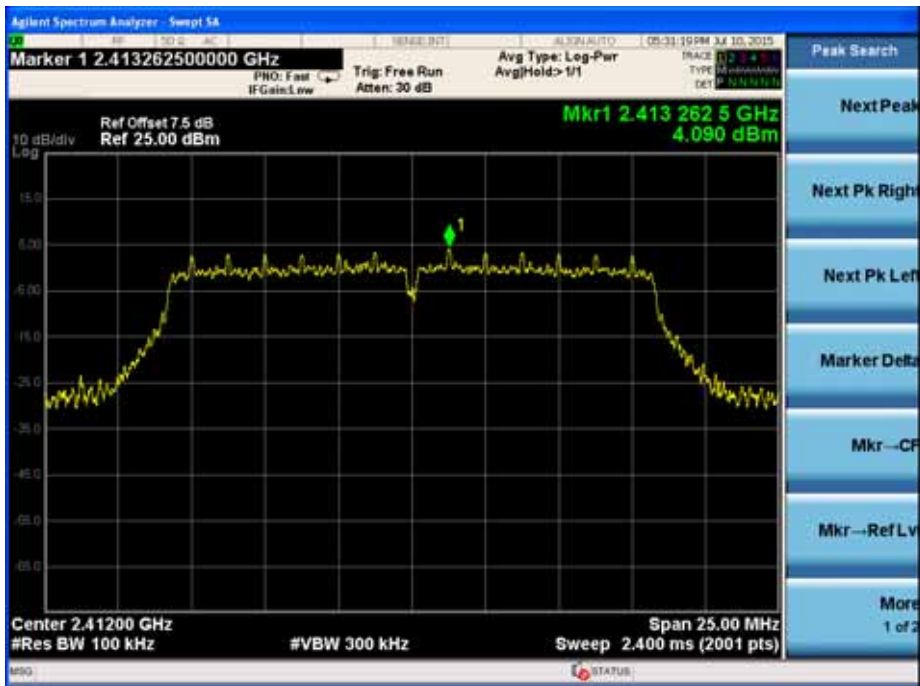

Low Band Edge - Frequency L

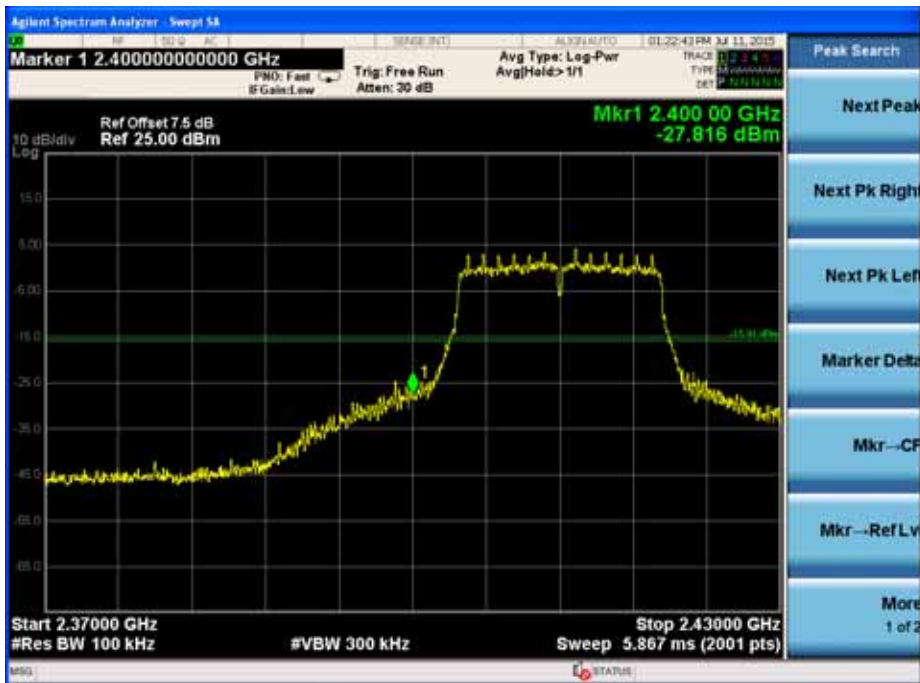

Spurious Emission 30MHz ~ 25GHz - Frequency L



Channel 06 (2437MHz) –Ant 1
Reference Level – Frequency M

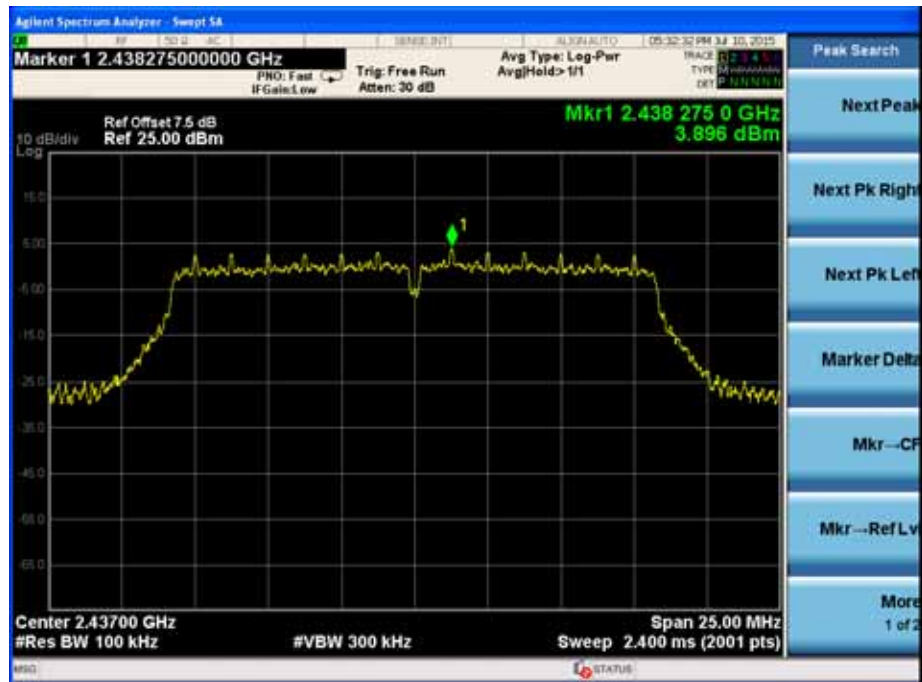

Spurious Emission 30MHz ~ 25GHz - Frequency M

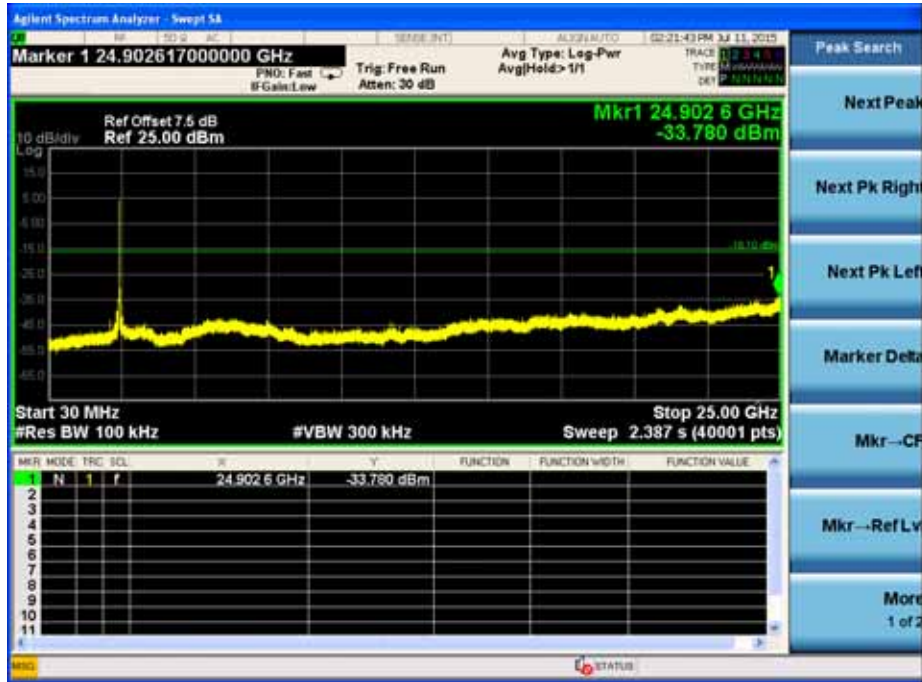

Channel 11 (2462MHz) –Ant 1
Reference Level – Frequency H



High Band Edge - Frequency H

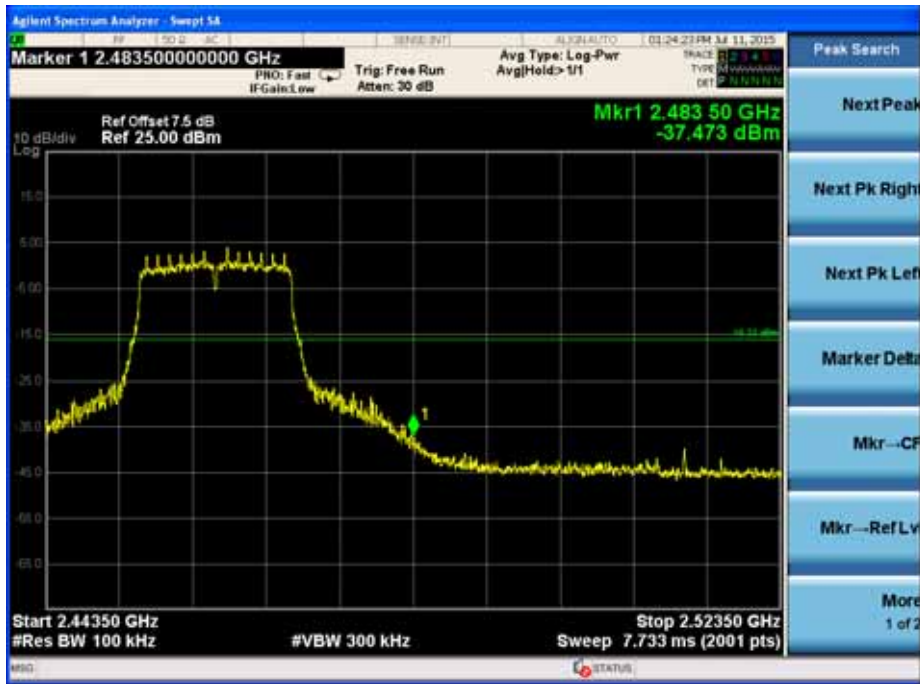

SSpurious Emission 30MHz ~ 25GHz - Frequency H

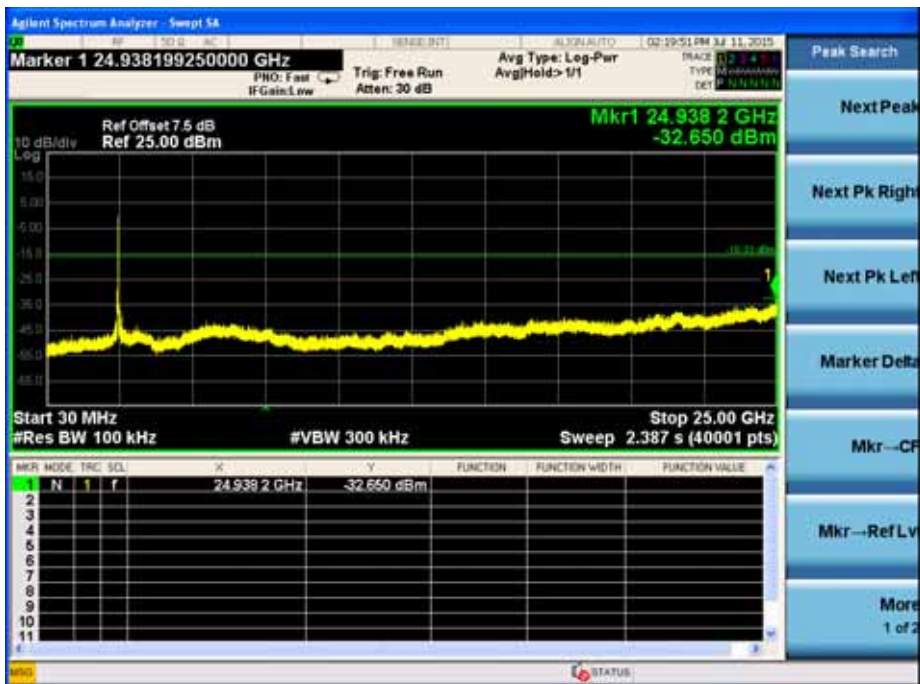

Product	: Wi-Fi Module
Test Item	: RF Antenna Conducted Spurious
Test Site	: TR-8
Test Mode	: Mode 3: Transmit by 802.11n(20MHz)

Channel 01 (2412MHz)-Ant 0
Reference Level – Frequency L



Low Band Edge - Frequency L

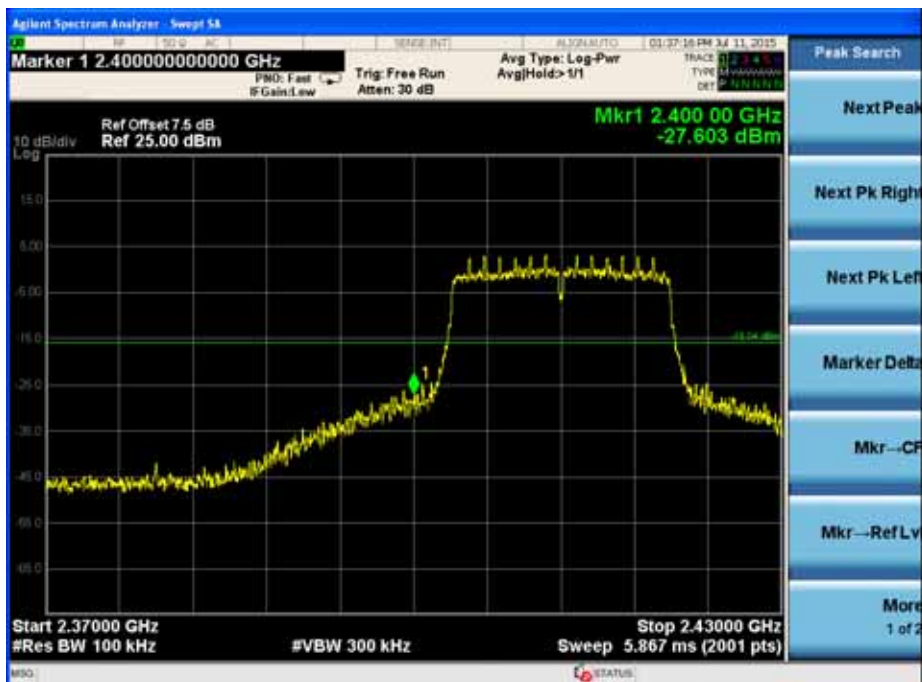

Spurious Emission 30MHz ~ 25GHz - Frequency L



Channel 06(2437MHz)-Ant 0
Reference Level – Frequency M



Spurious Emission 30MHz ~ 25GHz - Frequency M

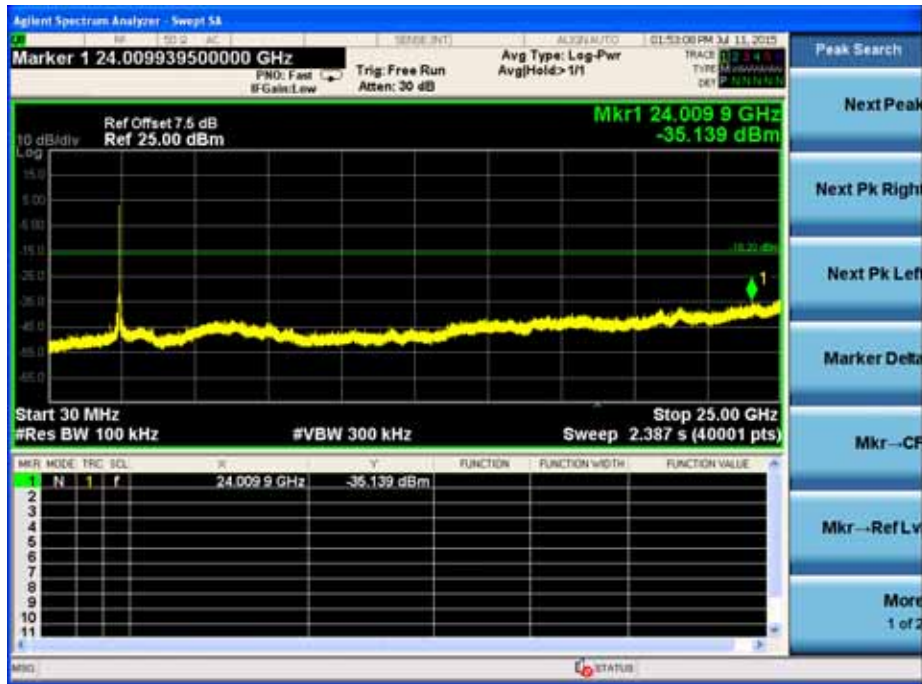

Channel 11 (2462MHz)-Ant 0
Reference Level – Frequency H

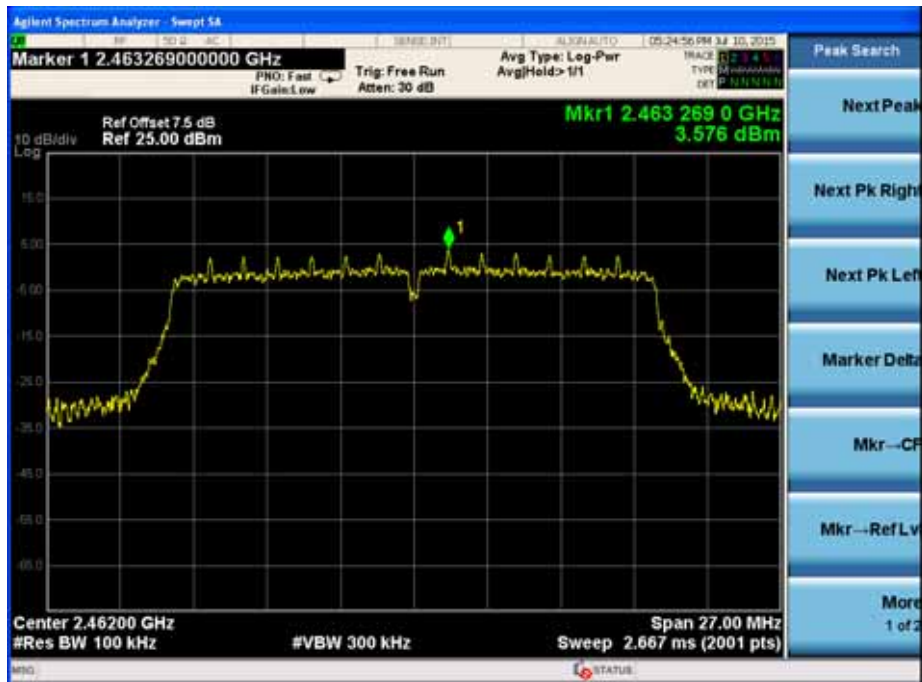

High Band Edge - Frequency H

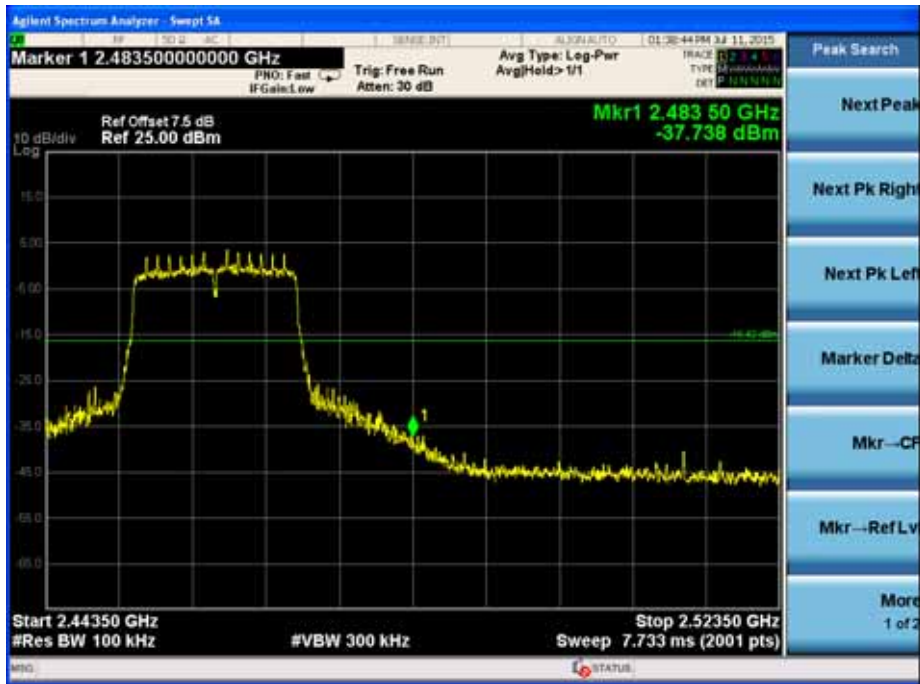

Spurious Emission 30MHz ~ 25GHz - Frequency H



Channel 01 (2412MHz)-Ant 1
 Reference Level – Frequency L

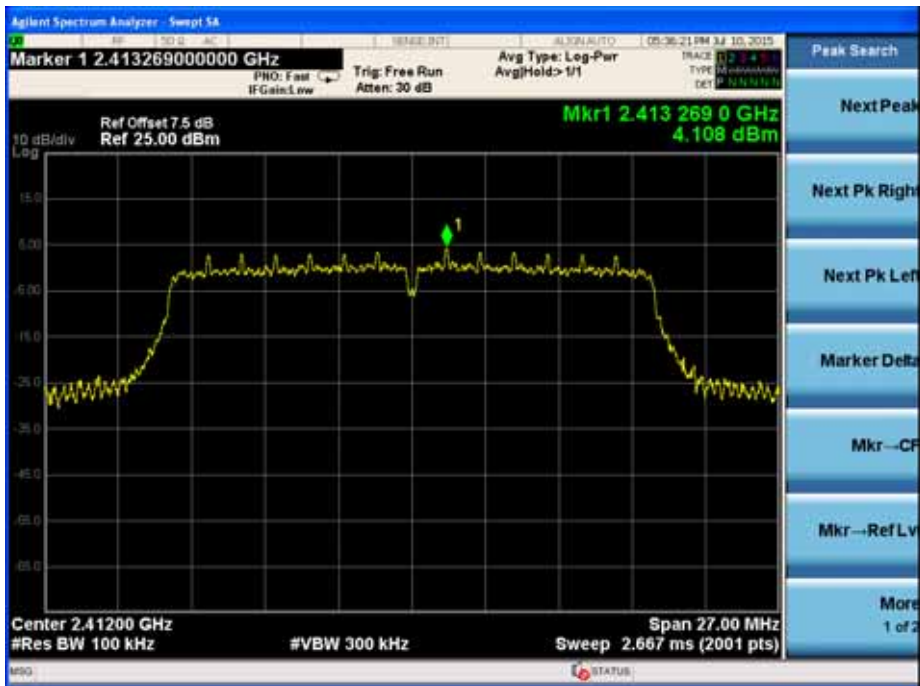

Low Band Edge - Frequency L

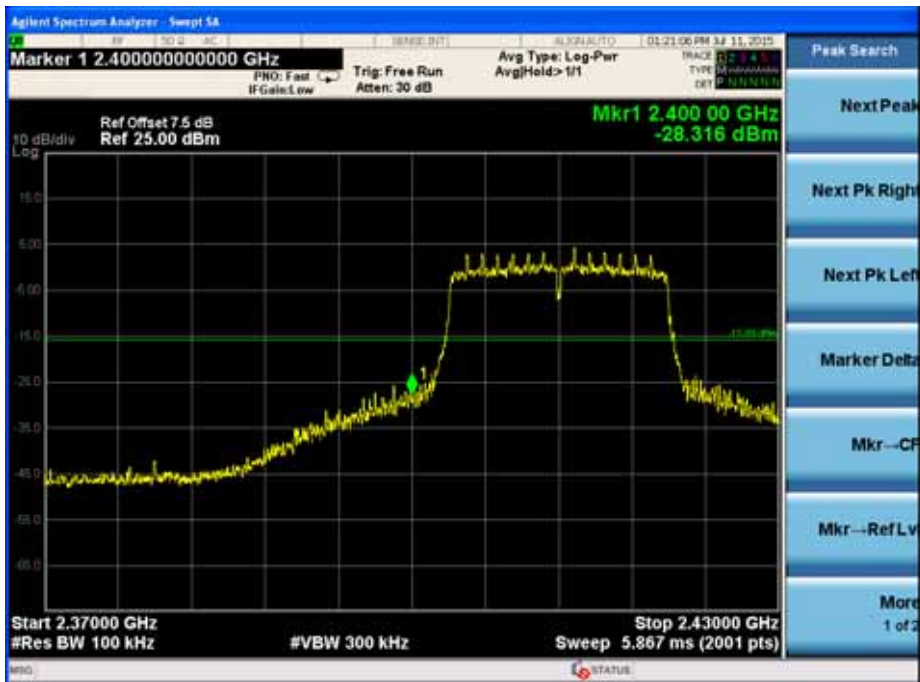

Spurious Emission 30MHz ~ 25GHz - Frequency L



Channel 06 (2437MHz)-Ant 1
Reference Level – Frequency M

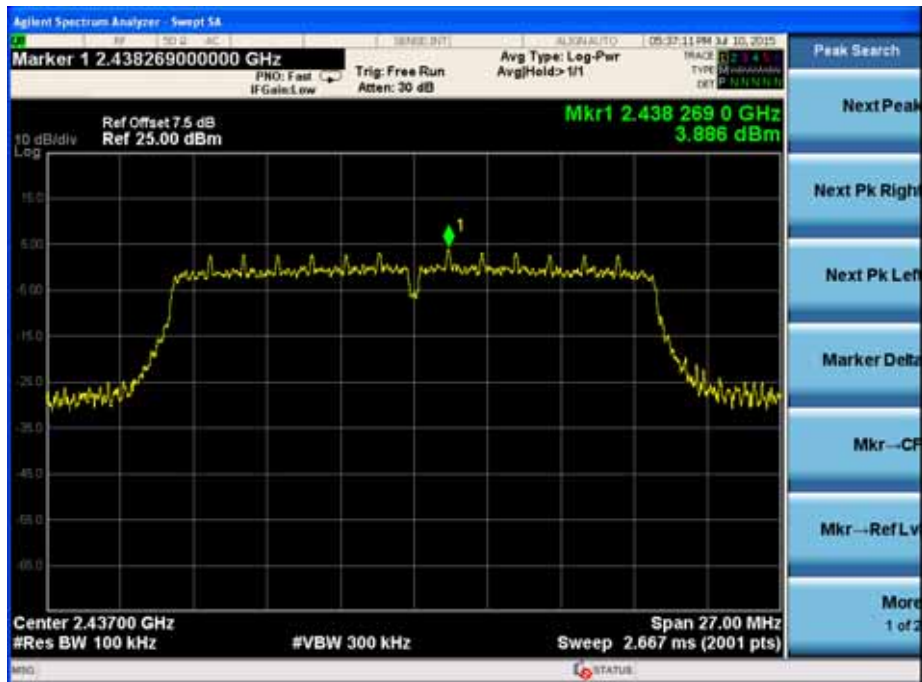

Spurious Emission 30MHz ~ 25GHz - Frequency M



Channel 11 (2462MHz)-Ant 1
Reference Level – Frequency H



High Band Edge - Frequency H



SSpurious Emission 30MHz ~ 25GHz - Frequency H

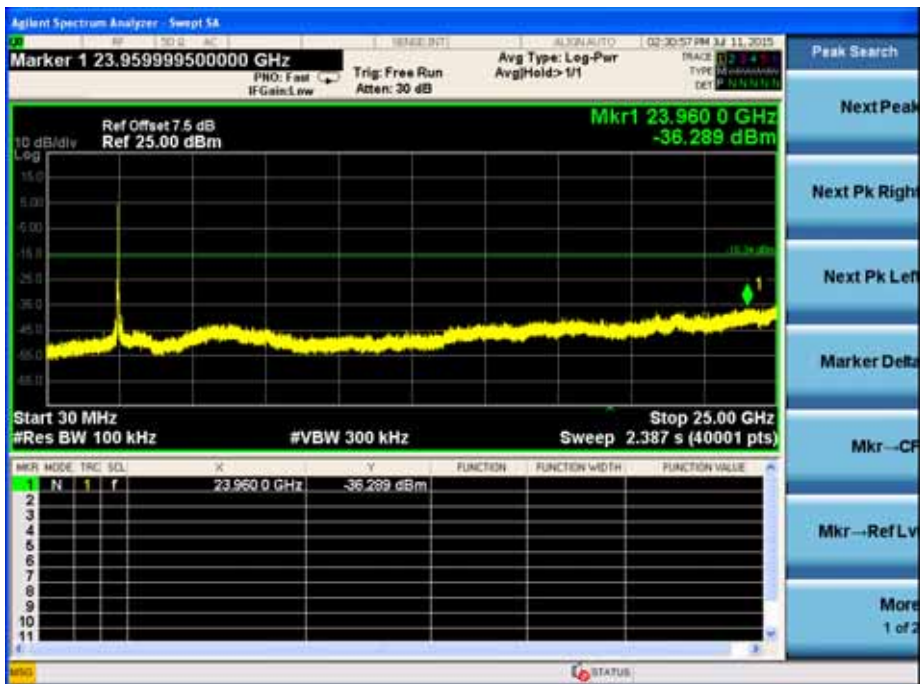

Product	: Wi-Fi Module
Test Item	: RF Antenna Conducted Spurious
Test Site	: TR-8
Test Mode	: Mode 4: Transmit by 802.11n(40MHz)

Channel 03 (2422MHz)-Ant 0
Reference Level – Frequency L

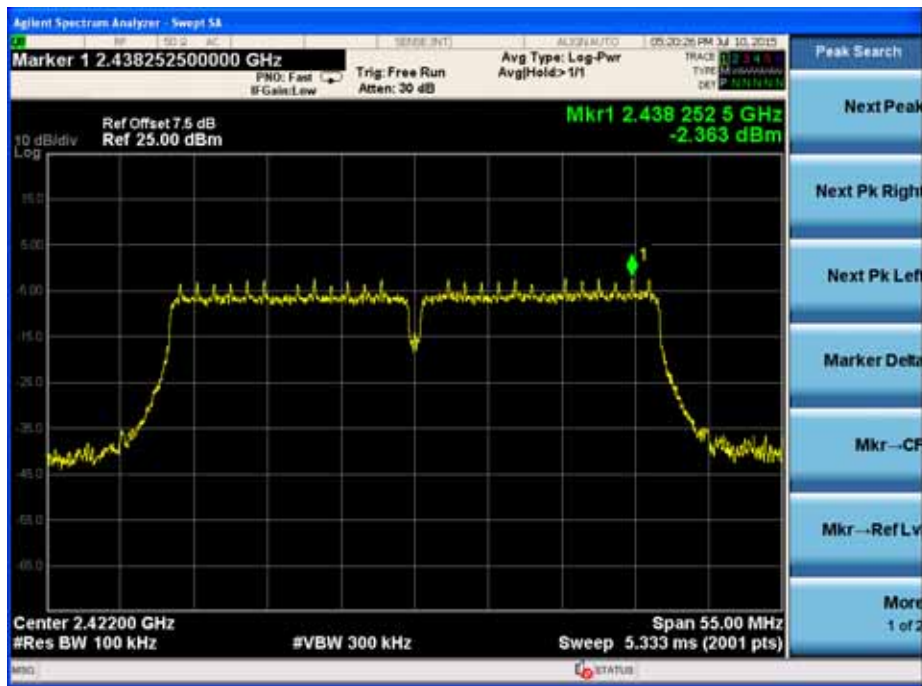

Low Band Edge - Frequency L



Spurious Emission 30MHz ~ 25GHz - Frequency L



Channel 06 (2437MHz)-Ant 0
 Reference Level – Frequency M

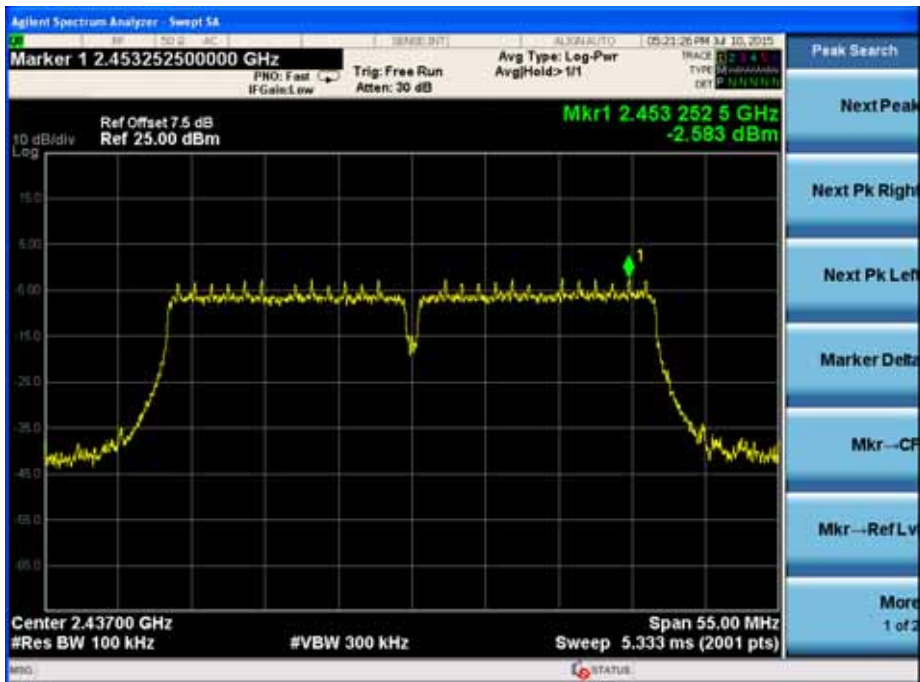

Spurious Emission 30MHz ~ 25GHz - Frequency M



Channel 09 (2452MHz)-Ant 0
Reference Level – Frequency H

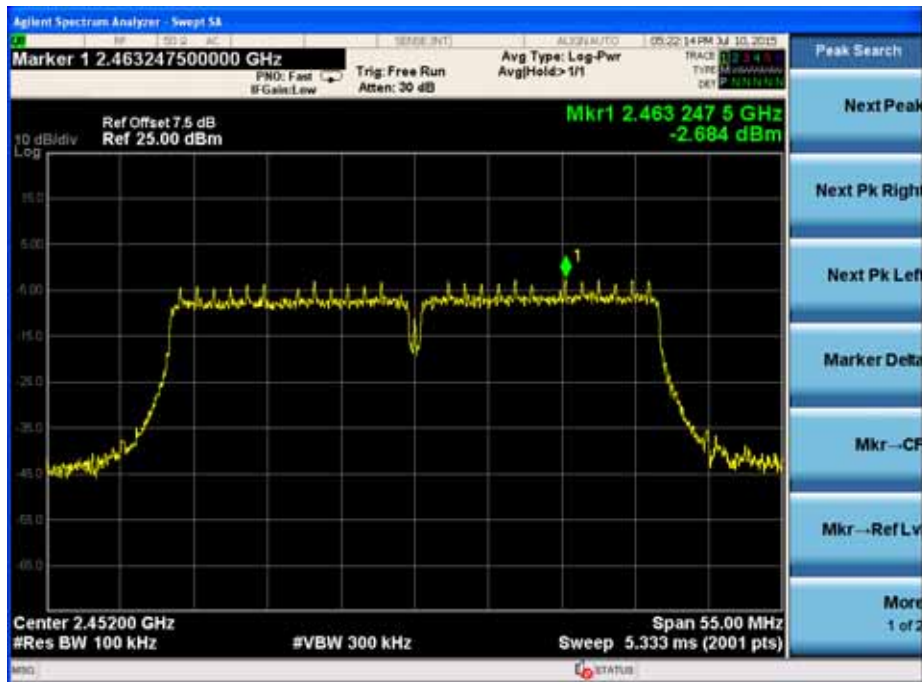

High Band Edge - Frequency H

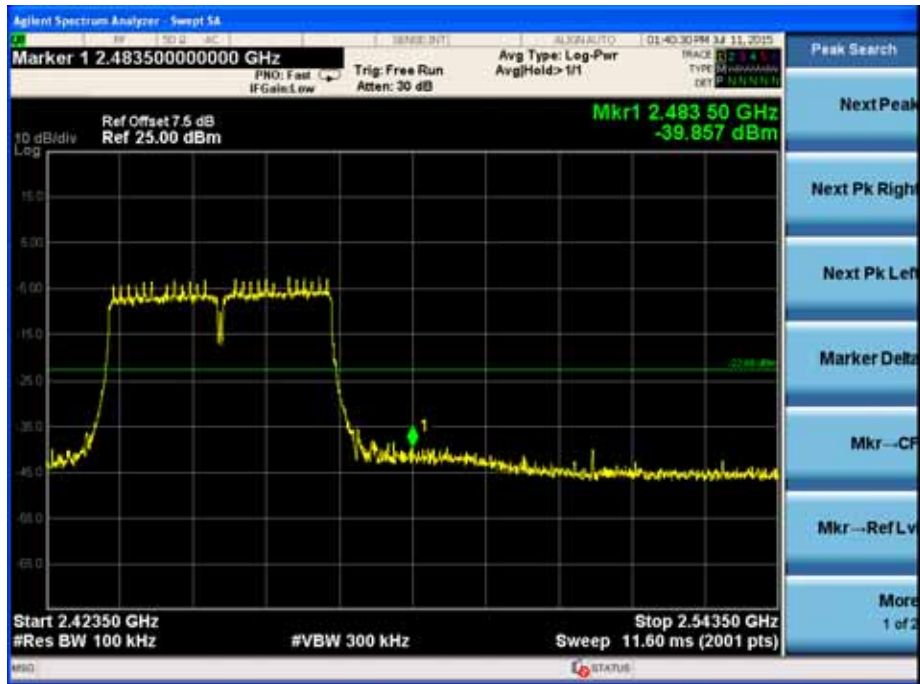

SSpurious Emission 30MHz ~ 25GHz - Frequency H



Channel 03 (2422MHz)-Ant 1
 Reference Level – Frequency L

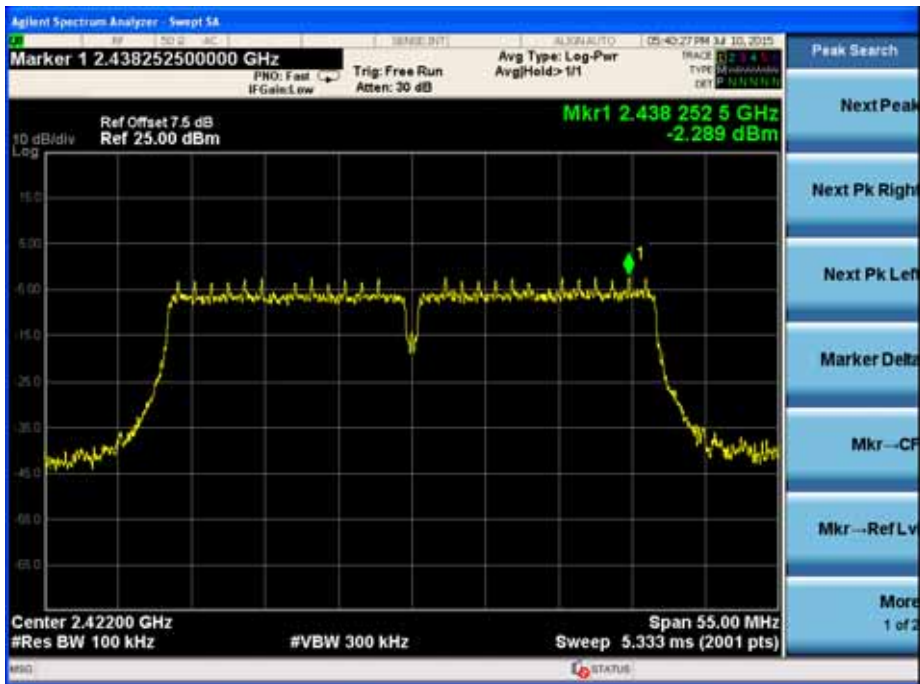

Low Band Edge - Frequency L



Spurious Emission 30MHz ~ 25GHz - Frequency L



Channel 06 (2437MHz)-Ant 1
Reference Level – Frequency M

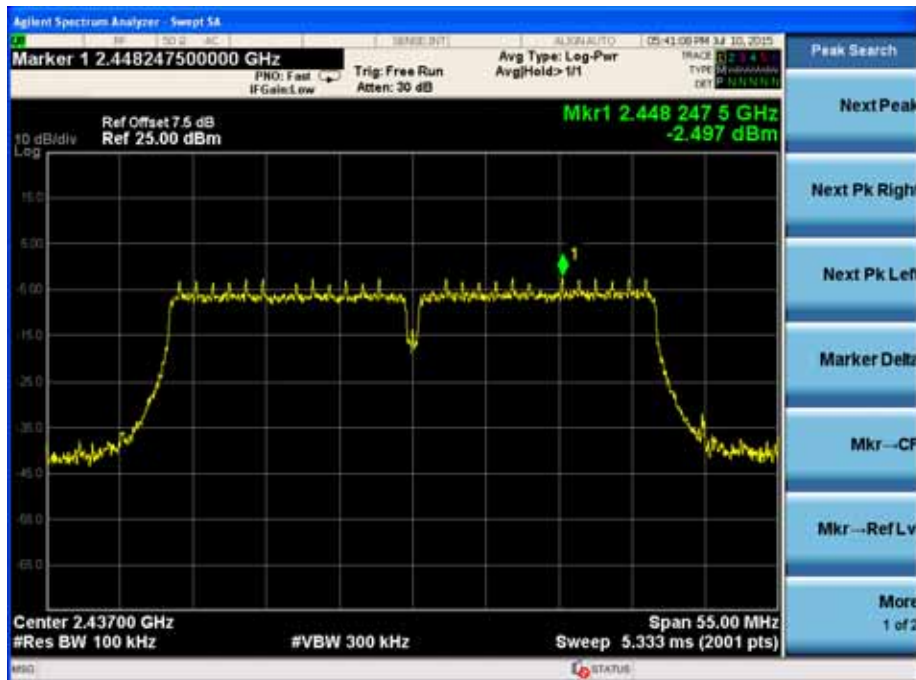

Spurious Emission 30MHz ~ 25GHz - Frequency M



Channel 09 (2452MHz)-Ant 1
Reference Level – Frequency H

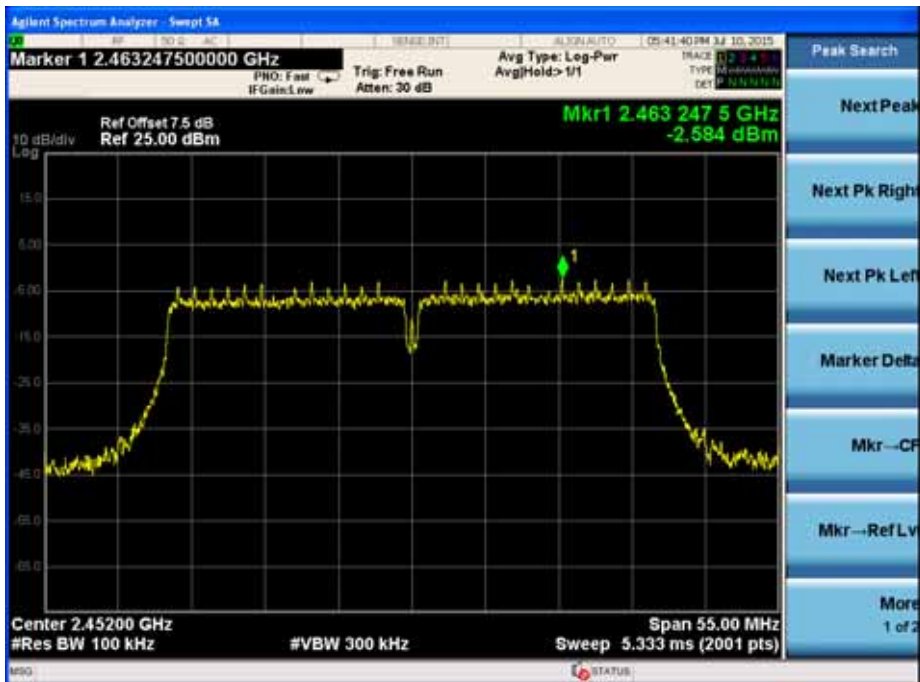

High Band Edge - Frequency H



Spurious Emission 30MHz ~ 25GHz - Frequency H



7. Radiated Emission Band Edge

7.1. Test Equipment

Radiated Emission Band Edge / AC-5

Instrument	Manufacturer	Type No.	Serial No.	Cali. Due Date
Spectrum Analyzer	Agilent	N9010A	MY48030494	2016.03.10
Preamplifier	Miteq	NSP1800-25	1364185	2016.05.03
Preamplifier	QuieTek	AP-040G	CHM-0906001	2016.05.03
Bilog Antenna	Teseq GmbH	CBL6112D	27612	2015.10.15
DRG Horn	ETS-Lindgren	3117	00123988	2016.01.07
Coaxial Cable	Huber+Suhner	SUCOFLEX 106	AC5-C1	2016.03.01
Coaxial Cable	Huber+Suhner	SUCOFLEX 106	AC5-C2	2016.03.01
Coaxial Cable	Huber+Suhner	SUCOFLEX 102	AC5-C3	2016.03.01
EMI Receiver	Agilent	N9038A	MY51210196	2016.06.09
Temperature/Humidity Meter	Zhichen	ZC1-2	AC5-TH	2016.01.08

Note 1: All equipments are calibrated with traceable calibrations. Each calibration is traceable to the national or international standards.

7.2. Test Setup

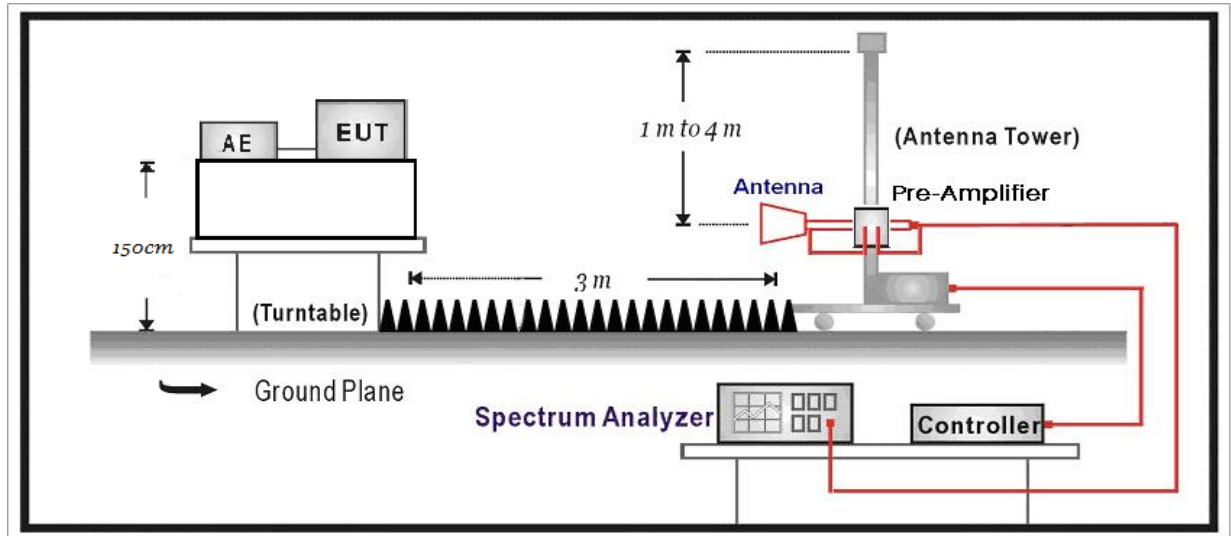

7.3. Limit

FCC&IC

Radiated emissions which fall in the restricted bands, as defined in Section 15.205(a) of FCC part 15, must also comply with the radiated emission limits specified in Section 15.209(a) (see Section 15.205(c)).

7.4. Test Procedure

According to FCC ANSI C63.4: 2014 & ANSI C63.10: 2013& FCC 47CFR 15.247& KDB 558074 D01v03r03& Industry Canada RSS-Gen Issue 4& RSS-247 Issue 1

This test is required for any spurious emission or modulation product that falls in a Restricted Band, as defined in Section 15.205 of FCC part 15. It must be performed with the highest gain of each type of antenna proposed for use with the EUT. Use the following spectrum analyzer settings:

Span = wide enough to fully capture the emission being measured

RBW = 1 MHz for $f \geq 1$ GHz, 100 kHz for $f < 1$ GHz

VBW \geq RBW

Sweep = auto

Detector function = peak

Trace = max hold

Follow the guidelines in ANSI C63.4 with respect to maximizing the emission by rotating the EUT, measuring the emission while the EUT is situated in three orthogonal planes (if appropriate), adjusting the measurement antenna height and polarization, etc. A pre-amp and a

high pass filter are required for this test, in order to provide the measuring system with sufficient sensitivity. Allow the trace to stabilize. The peak reading of the emission, after being corrected by the antenna factor, cable loss, pre-amp gain, etc., is the peak field strength, which must comply with the limit specified in Section 15.35(b) of FCC part 15.

Now set the VBW $\geq 1 / T$ (the minimum transmission duration), while maintaining all of the other instrument settings. This peak level, once corrected, must comply with the limit specified in Section 15.209 of FCC Part 15.

If the emission on which a radiated measurement must be made is located at the edge of the authorized band of operation, then the alternative “marker-Wi-Fi Module” method may be employed.

7.5. Uncertainty

The measurement uncertainty above 1G is defined as ± 3.9 dB

7.6. Test Result

Measure Level = Reading Level + Cable Loss + Antenna Factor - Preamplifier Gain

Note: when the duty cycle is less than 98%, a duty cycle factor is calculated in the correction factor.

Site: AC5	Time: 2015/06/24 - 11:09
Limit: FCC_Part15.209_RE(3m)	Margin: 0
Probe: Horn_3117_00167055(1-18GHz)	Polarity: Vertical
EUT: Wi-Fi Module	Power: AC 120V/60Hz
Note: Mode 1 Transmit at 802.11b CH2412 by ant0	

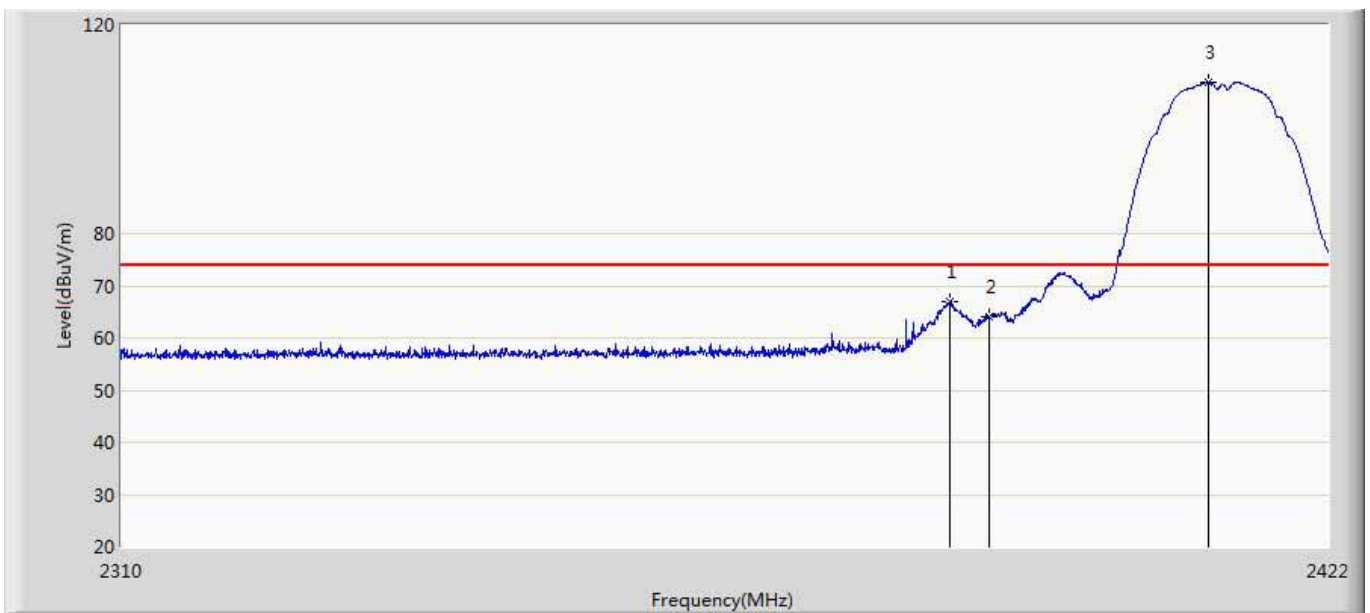

No	Mark	Frequency (MHz)	Measure Level (dBuV/m)	Reading Level (dBuV)	Over Limit (dB)	Limit (dBuV/m)	Factor (dB)	Type
1		2386.328	66.955	30.936	-7.045	74.000	36.019	PK
2		2390.000	64.004	27.968	-9.996	74.000	36.037	PK
3	*	2410.632	108.971	72.839	34.971	74.000	36.132	PK

Site: AC5	Time: 2015/06/24 - 11:12
Limit: FCC_Part15.209_RE(3m)	Margin: 0
Probe: Horn_3117_00167055(1-18GHz)	Polarity: Vertical
EUT: Wi-Fi Module	Power: AC 120V/60Hz
Note: Mode 1 Transmit at 802.11b CH2412 by ant0	

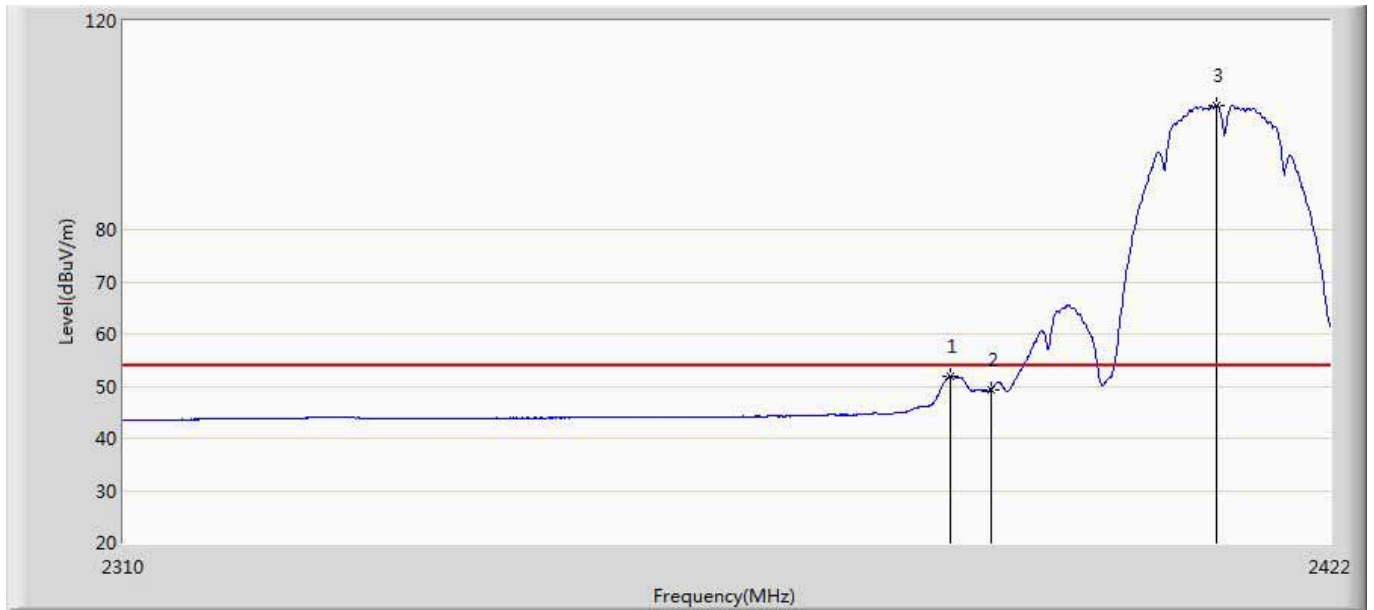

No	Mark	Frequency (MHz)	Measure Level (dBuV/m)	Reading Level (dBuV)	Over Limit (dB)	Limit (dBuV/m)	Factor (dB)	Type
1		2386.160	51.968	15.950	-2.032	54.000	36.019	AV
2		2390.000	49.396	13.360	-4.604	54.000	36.037	AV
3	*	2411.192	103.820	67.686	49.820	54.000	36.135	AV

Site: AC5	Time: 2015/06/24 - 11:21
Limit: FCC_Part15.209_RE(3m)	Margin: 0
Probe: Horn_3117_00167055(1-18GHz)	Polarity: Horizontal
EUT: Wi-Fi Module	Power: AC 120V/60Hz
Note: Mode 1 Transmit at 802.11b CH2412 by ant0	

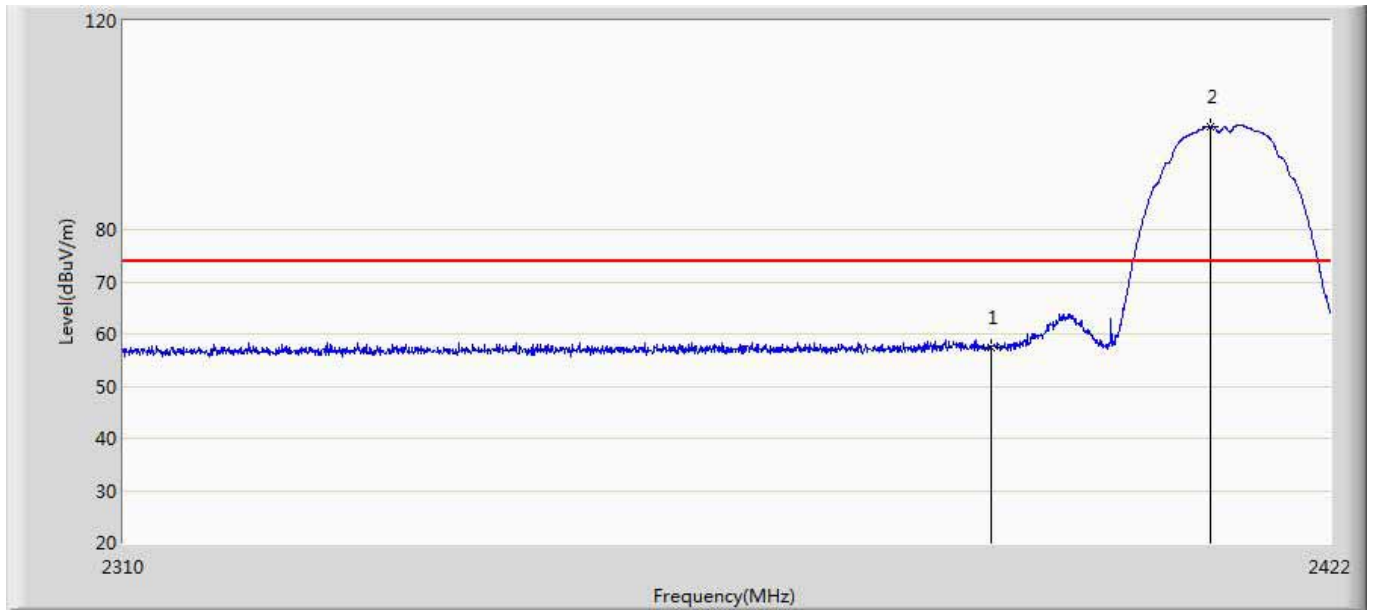

No	Mark	Frequency (MHz)	Measure Level (dBuV/m)	Reading Level (dBuV)	Over Limit (dB)	Limit (dBuV/m)	Factor (dB)	Type
1		2390.000	57.424	21.388	-16.576	74.000	36.037	PK
2	*	2410.632	99.754	63.622	25.754	74.000	36.132	PK

Site: AC5	Time: 2015/06/24 - 11:23
Limit: FCC_Part15.209_RE(3m)	Margin: 0
Probe: Horn_3117_00167055(1-18GHz)	Polarity: Horizontal
EUT: Wi-Fi Module	Power: AC 120V/60Hz
Note: Mode 1 Transmit at 802.11b CH2412 by ant0	

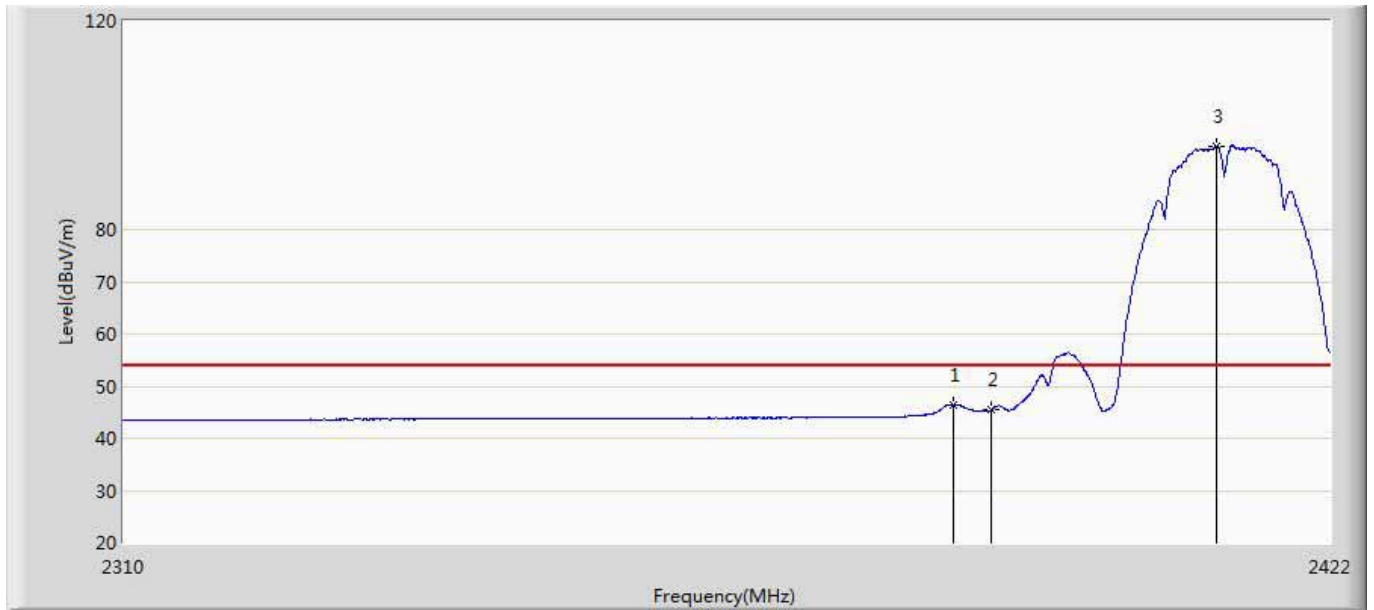

No	Mark	Frequency (MHz)	Measure Level (dBuV/m)	Reading Level (dBuV)	Over Limit (dB)	Limit (dBuV/m)	Factor (dB)	Type
1		2386.496	46.422	10.402	-7.578	54.000	36.020	AV
2		2390.000	45.403	9.367	-8.597	54.000	36.037	AV
3	*	2411.192	95.990	59.856	41.990	54.000	36.135	AV

Site: AC5	Time: 2015/06/24 - 11:27
Limit: FCC_Part15.209_RE(3m)	Margin: 0
Probe: Horn_3117_00167055(1-18GHz)	Polarity: Vertical
EUT: Wi-Fi Module	Power: AC 120V/60Hz
Note: Mode 1 Transmit at 802.11b CH2462 by ant0	

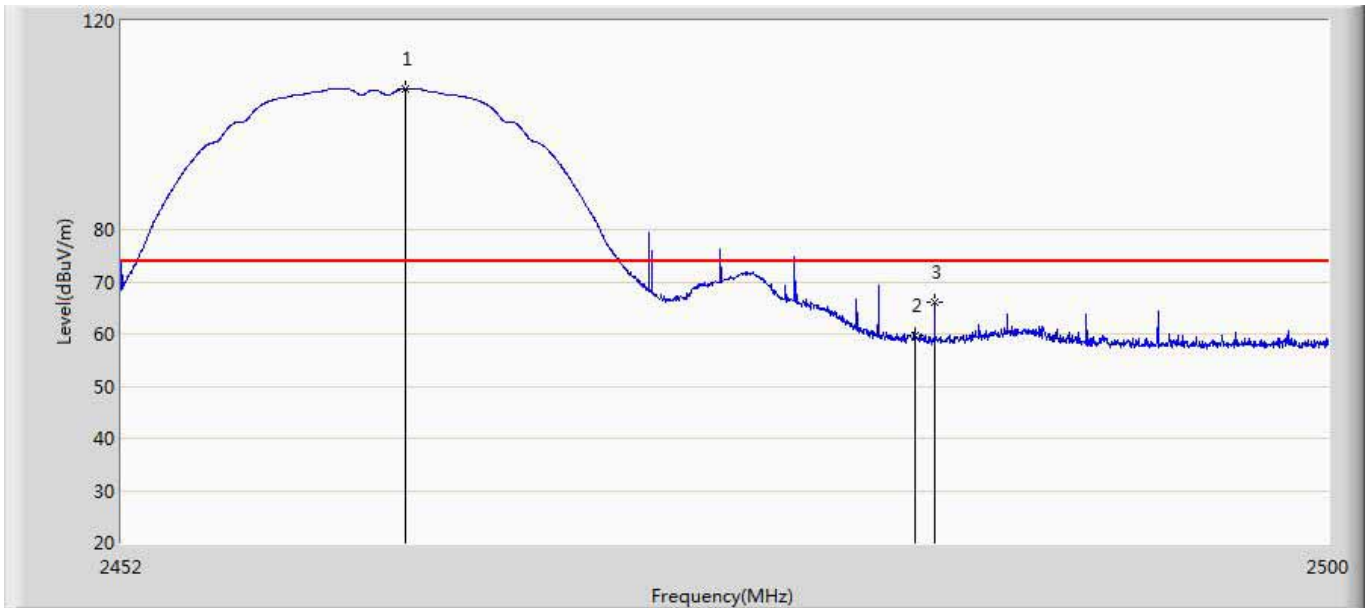

No	Mark	Frequency (MHz)	Measure Level (dBuV/m)	Reading Level (dBuV)	Over Limit (dB)	Limit (dBuV/m)	Factor (dB)	Type
1	*	2463.232	106.960	70.589	32.960	74.000	36.370	PK
2		2483.500	59.730	23.265	-14.270	74.000	36.465	PK
3		2484.256	66.130	29.661	-7.870	74.000	36.469	PK

Site: AC5	Time: 2015/06/24 - 11:30
Limit: FCC_Part15.209_RE(3m)	Margin: 0
Probe: Horn_3117_00167055(1-18GHz)	Polarity: Vertical
EUT: Wi-Fi Module	Power: AC 120V/60Hz
Note: Mode 1 Transmit at 802.11b CH2462 by ant0	

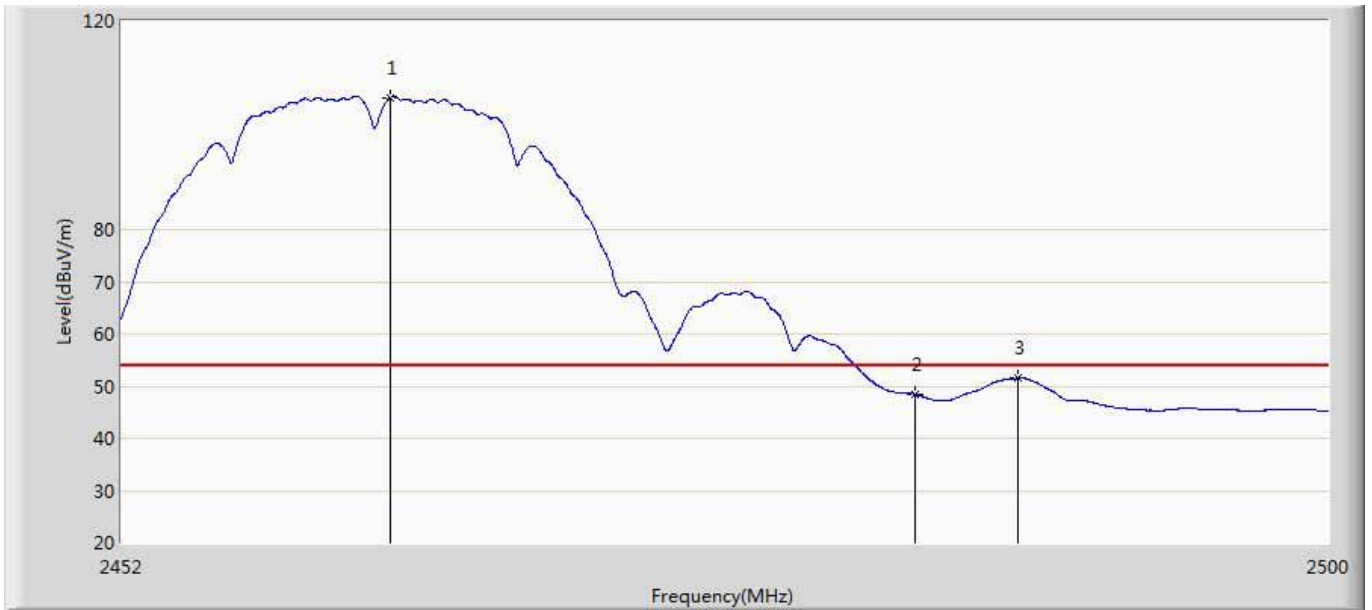

No	Mark	Frequency (MHz)	Measure Level (dBuV/m)	Reading Level (dBuV)	Over Limit (dB)	Limit (dBuV/m)	Factor (dB)	Type
1	*	2462.632	105.270	68.902	51.270	54.000	36.368	AV
2		2483.500	48.432	11.967	-5.568	54.000	36.465	AV
3		2487.568	51.467	14.983	-2.533	54.000	36.484	AV

Site: AC5	Time: 2015/06/24 - 11:32
Limit: FCC_Part15.209_RE(3m)	Margin: 0
Probe: Horn_3117_00167055(1-18GHz)	Polarity: Horizontal
EUT: Wi-Fi Module	Power: AC 120V/60Hz
Note: Mode 1 Transmit at 802.11b CH2462 by ant0	

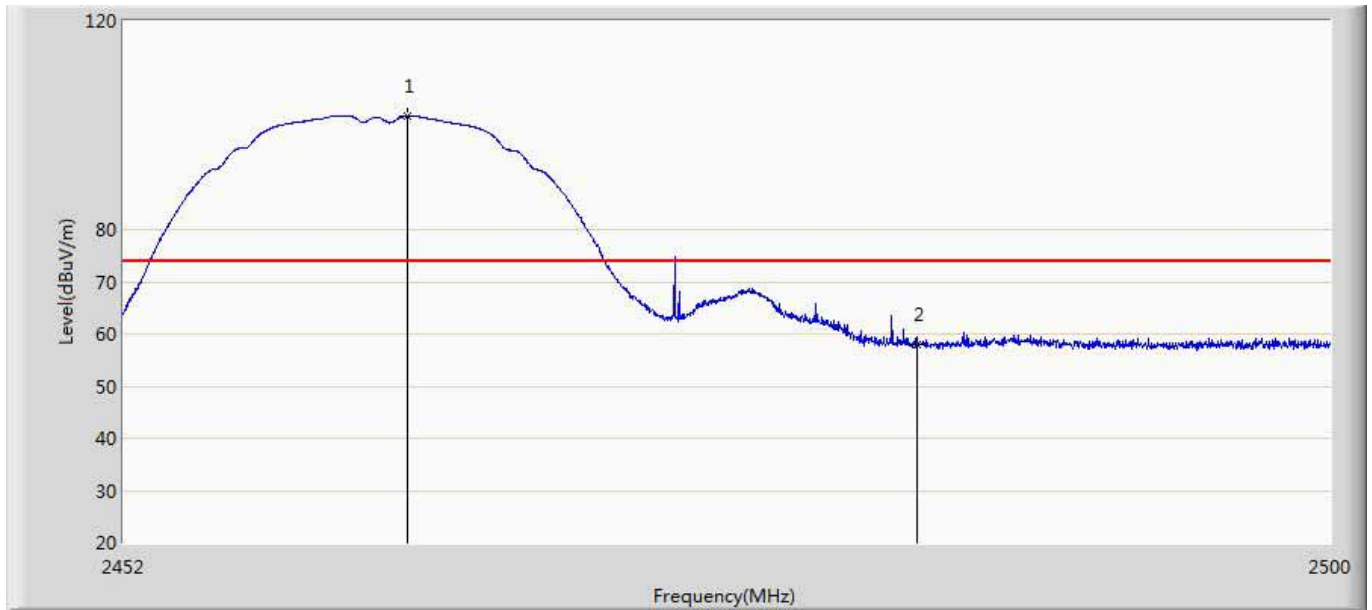

No	Mark	Frequency (MHz)	Measure Level (dBuV/m)	Reading Level (dBuV)	Over Limit (dB)	Limit (dBuV/m)	Factor (dB)	Type
1	*	2463.232	101.653	65.282	27.653	74.000	36.370	PK
2		2483.500	57.862	21.397	-16.138	74.000	36.465	PK

Site: AC5	Time: 2015/06/24 - 11:34
Limit: FCC_Part15.209_RE(3m)	Margin: 0
Probe: Horn_3117_00167055(1-18GHz)	Polarity: Horizontal
EUT: Wi-Fi Module	Power: AC 120V/60Hz
Note: Mode 1 Transmit at 802.11b CH2462 by ant0	

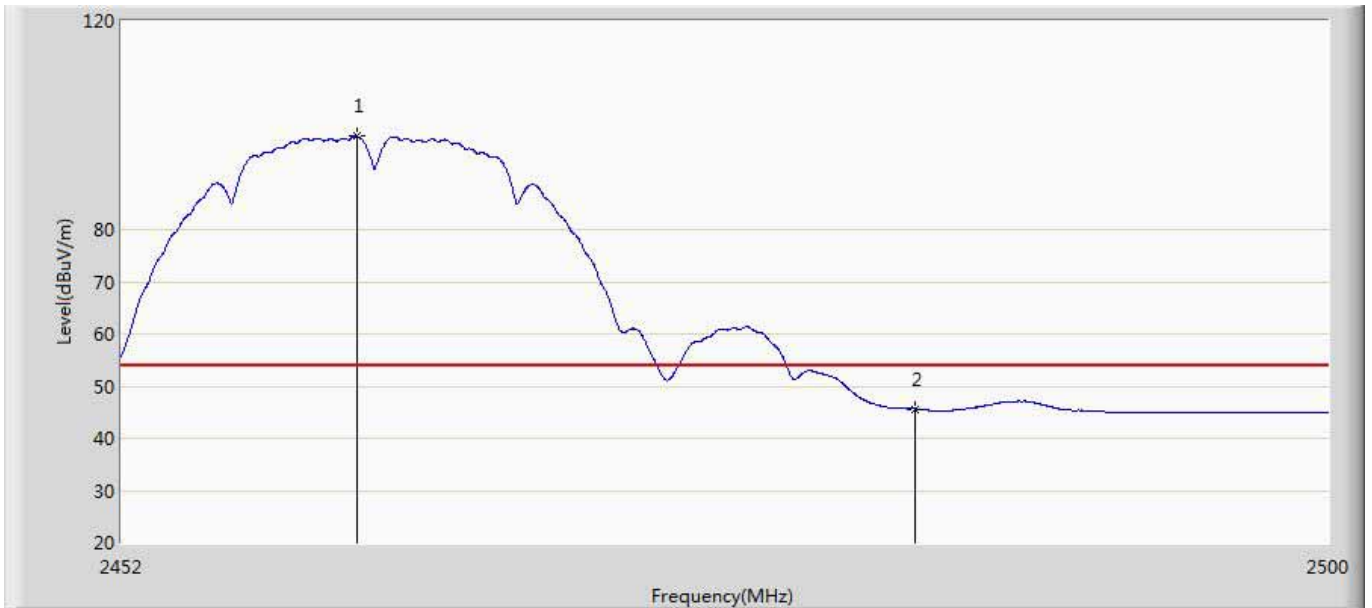

No	Mark	Frequency (MHz)	Measure Level (dBuV/m)	Reading Level (dBuV)	Over Limit (dB)	Limit (dBuV/m)	Factor (dB)	Type
1	*	2461.288	97.871	61.509	43.871	54.000	36.361	AV
2		2483.500	45.631	9.166	-8.369	54.000	36.465	AV

Site: AC5	Time: 2015/06/24 - 11:53
Limit: FCC_Part15.209_RE(3m)	Margin: 0
Probe: Horn_3117_00167055(1-18GHz)	Polarity: Vertical
EUT: Wi-Fi Module	Power: AC 120V/60Hz
Note: Mode 2 Transmit at 802.11g CH2412 by ant0	

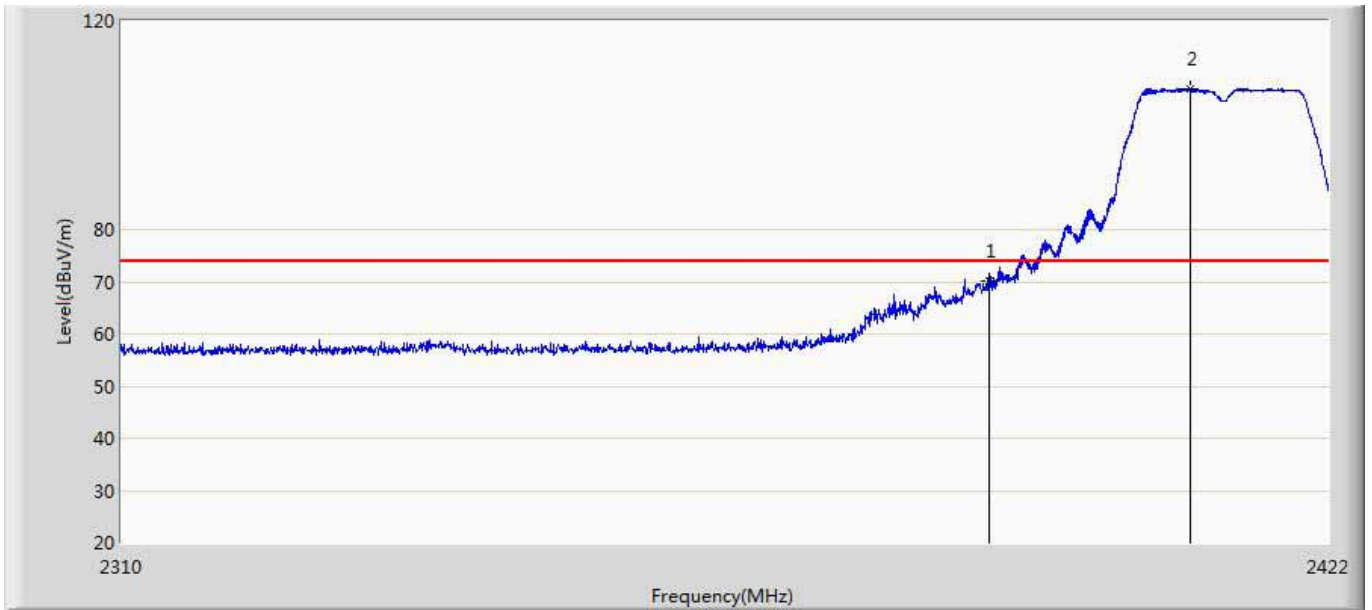

No	Mark	Frequency (MHz)	Measure Level (dBuV/m)	Reading Level (dBuV)	Over Limit (dB)	Limit (dBuV/m)	Factor (dB)	Type
1		2390.000	70.039	34.003	-3.961	74.000	36.037	PK
2	*	2408.896	106.903	70.779	32.903	74.000	36.123	PK

Site: AC5	Time: 2015/06/24 - 11:53
Limit: FCC_Part15.209_RE(3m)	Margin: 0
Probe: Horn_3117_00167055(1-18GHz)	Polarity: Vertical
EUT: Wi-Fi Module	Power: AC 120V/60Hz
Note: Mode 2 Transmit at 802.11g CH2412 by ant0	

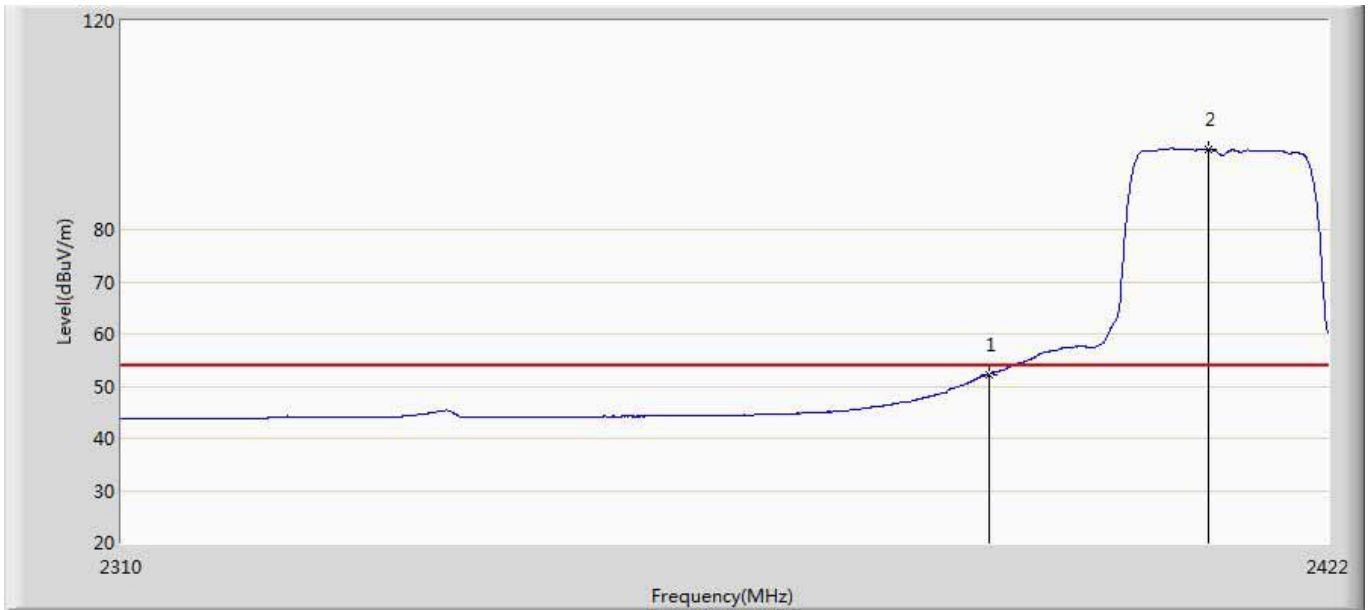

No	Mark	Frequency (MHz)	Measure Level (dBuV/m)	Reading Level (dBuV)	Over Limit (dB)	Limit (dBuV/m)	Factor (dB)	Type
1		2390.000	52.225	16.189	-1.775	54.000	36.037	AV
2	*	2410.632	95.433	59.301	41.433	54.000	36.132	AV

Site: AC5	Time: 2015/06/24 - 12:02
Limit: FCC_Part15.209_RE(3m)	Margin: 0
Probe: Horn_3117_00167055(1-18GHz)	Polarity: Horizontal
EUT: Wi-Fi Module	Power: AC 120V/60Hz
Note: Mode 2 Transmit at 802.11g CH2412 by ant0	

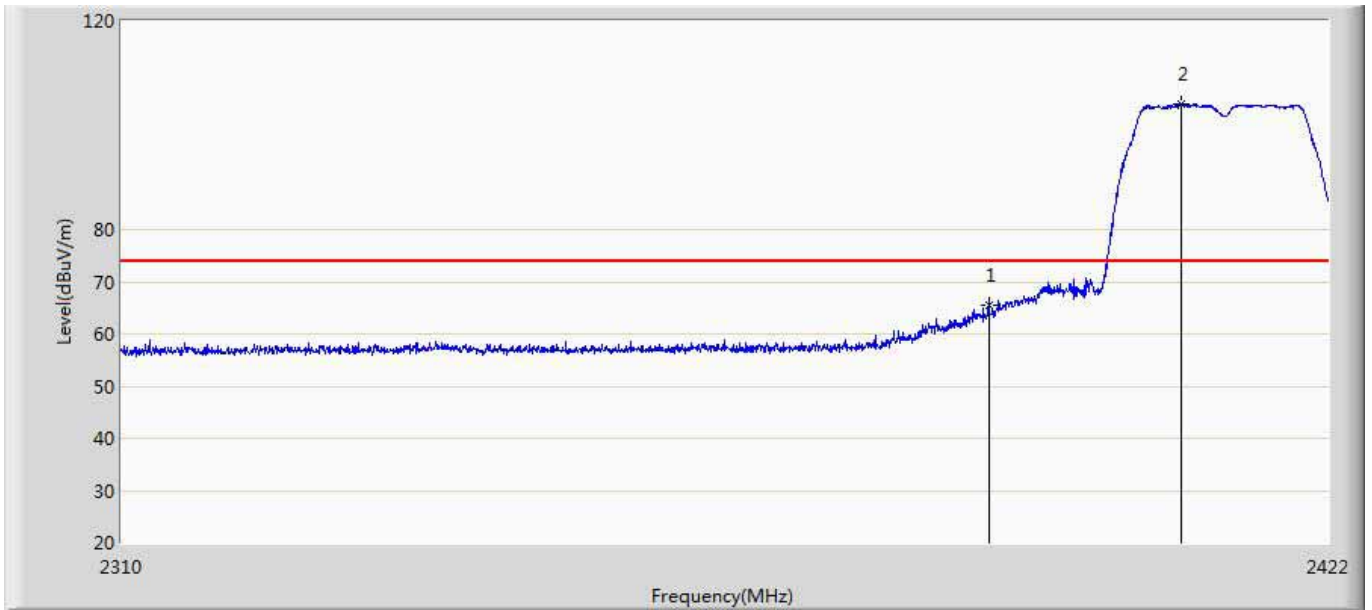

No	Mark	Frequency (MHz)	Measure Level (dBuV/m)	Reading Level (dBuV)	Over Limit (dB)	Limit (dBuV/m)	Factor (dB)	Type
1		2390.000	65.430	29.394	-8.570	74.000	36.037	PK
2	*	2408.056	104.010	67.890	30.010	74.000	36.120	PK

Site: AC5	Time: 2015/06/24 - 12:03
Limit: FCC_Part15.209_RE(3m)	Margin: 0
Probe: Horn_3117_00167055(1-18GHz)	Polarity: Horizontal
EUT: Wi-Fi Module	Power: AC 120V/60Hz
Note: Mode 2 Transmit at 802.11g CH2412 by ant0	

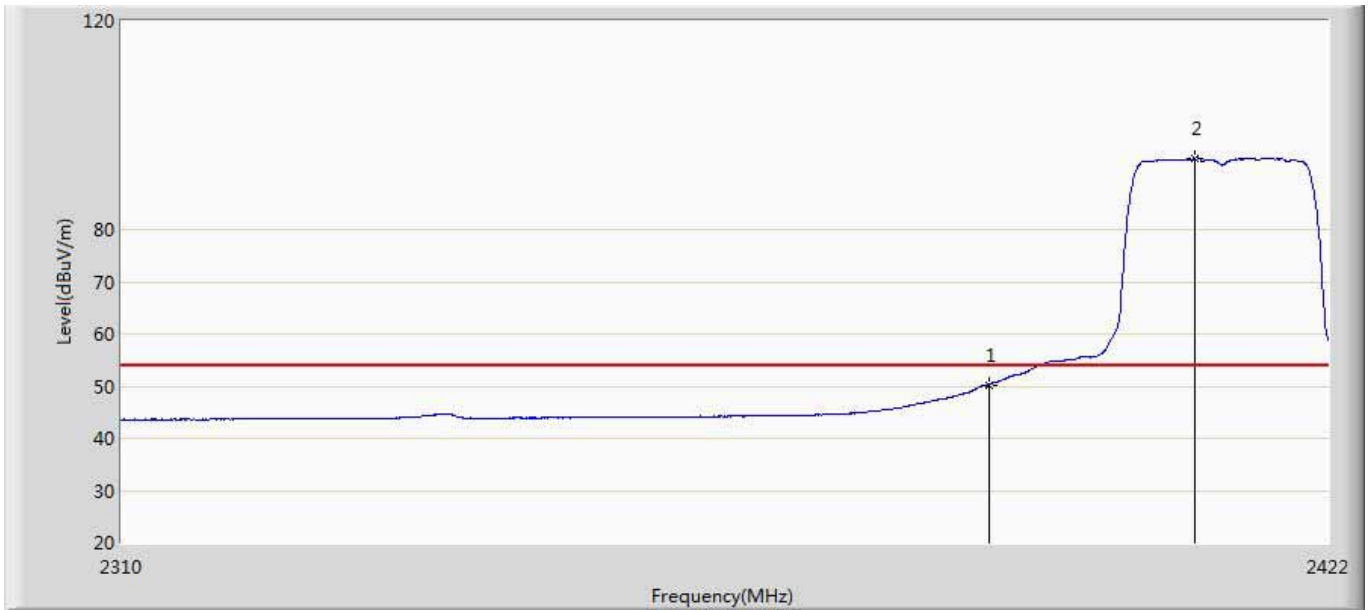

No	Mark	Frequency (MHz)	Measure Level (dBuV/m)	Reading Level (dBuV)	Over Limit (dB)	Limit (dBuV/m)	Factor (dB)	Type
1		2390.000	50.238	14.202	-3.762	54.000	36.037	AV
2	*	2409.456	93.763	57.637	39.763	54.000	36.126	AV

Site: AC5	Time: 2015/06/24 - 13:32
Limit: FCC_Part15.209_RE(3m)	Margin: 0
Probe: Horn_3117_00167055(1-18GHz)	Polarity: Vertical
EUT: Wi-Fi Module	Power: AC 120V/60Hz
Note: Mode 2 Transmit at 802.11g CH2462 by ant0	

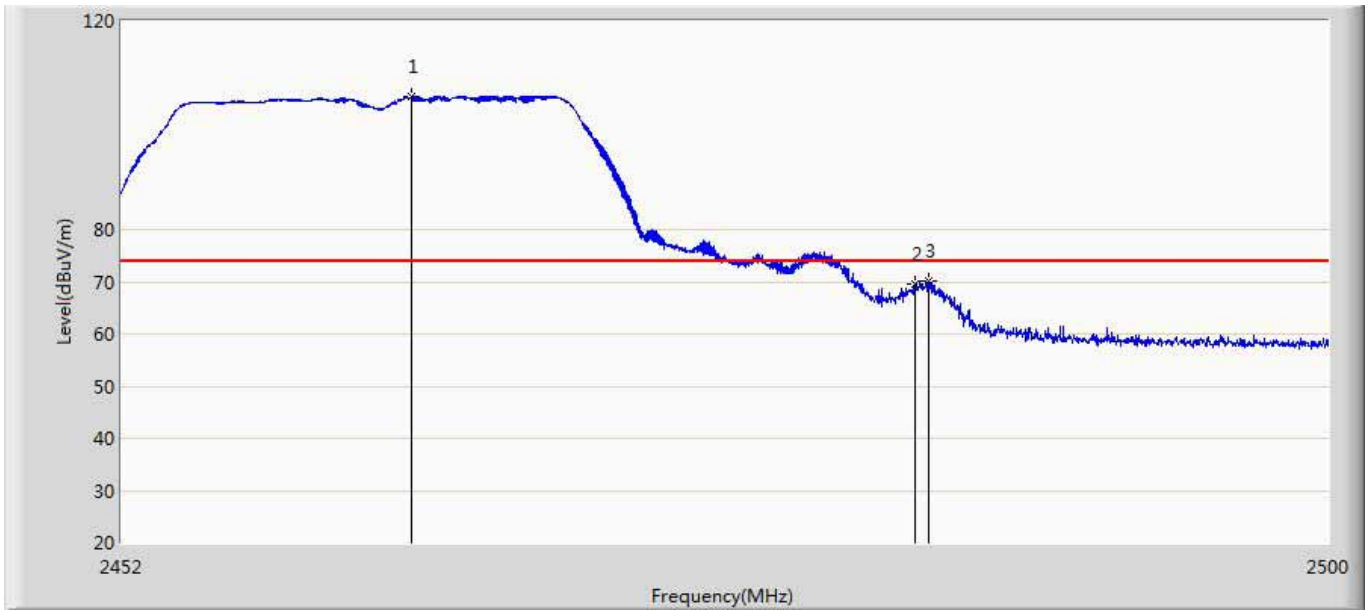

No	Mark	Frequency (MHz)	Measure Level (dBuV/m)	Reading Level (dBuV)	Over Limit (dB)	Limit (dBuV/m)	Factor (dB)	Type
1	*	2463.448	105.377	69.005	31.377	74.000	36.372	PK
2		2483.500	69.531	33.066	-4.469	74.000	36.465	PK
3		2483.992	70.287	33.819	-3.713	74.000	36.467	PK

Site: AC5	Time: 2015/06/24 - 13:33
Limit: FCC_Part15.209_RE(3m)	Margin: 0
Probe: Horn_3117_00167055(1-18GHz)	Polarity: Vertical
EUT: Wi-Fi Module	Power: AC 120V/60Hz
Note: Mode 2 Transmit at 802.11g CH2462 by ant0	

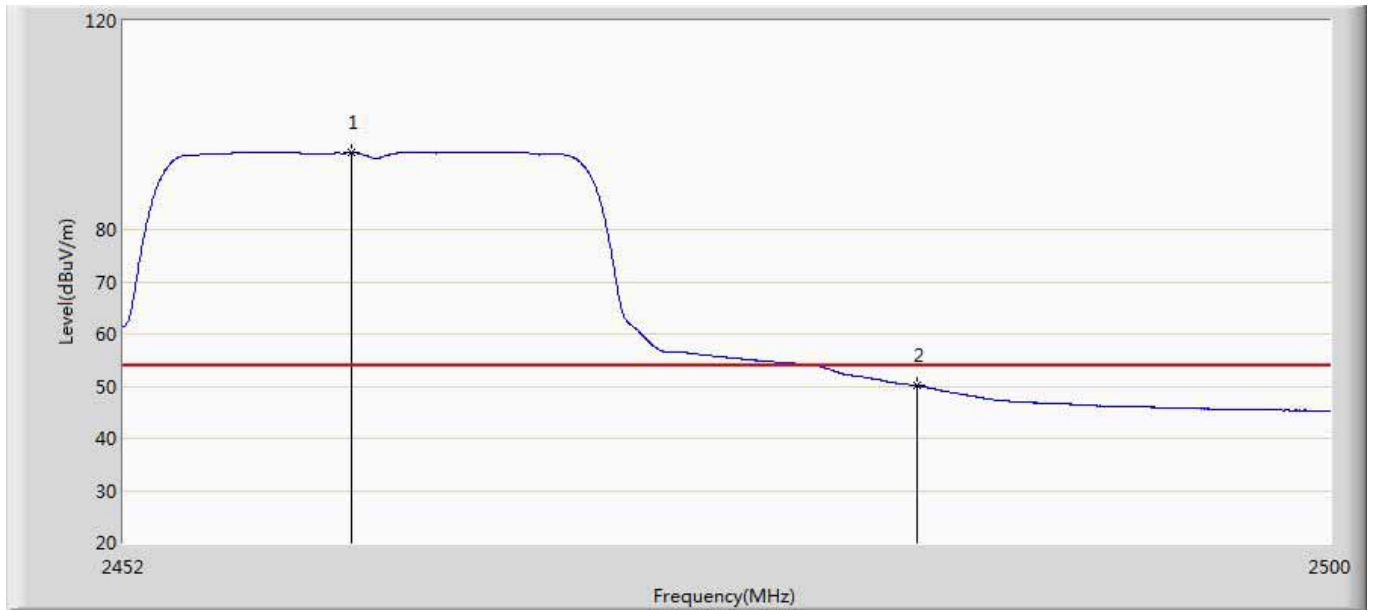

No	Mark	Frequency (MHz)	Measure Level (dBuV/m)	Reading Level (dBuV)	Over Limit (dB)	Limit (dBuV/m)	Factor (dB)	Type
1	*	2461.000	94.751	58.390	40.751	54.000	36.360	AV
2		2483.500	50.088	13.623	-3.912	54.000	36.465	AV

Site: AC5	Time: 2015/06/24 - 13:40
Limit: FCC_Part15.209_RE(3m)	Margin: 0
Probe: Horn_3117_00167055(1-18GHz)	Polarity: Horizontal
EUT: Wi-Fi Module	Power: AC 120V/60Hz
Note: Mode 2 Transmit at 802.11g CH2462 by ant0	

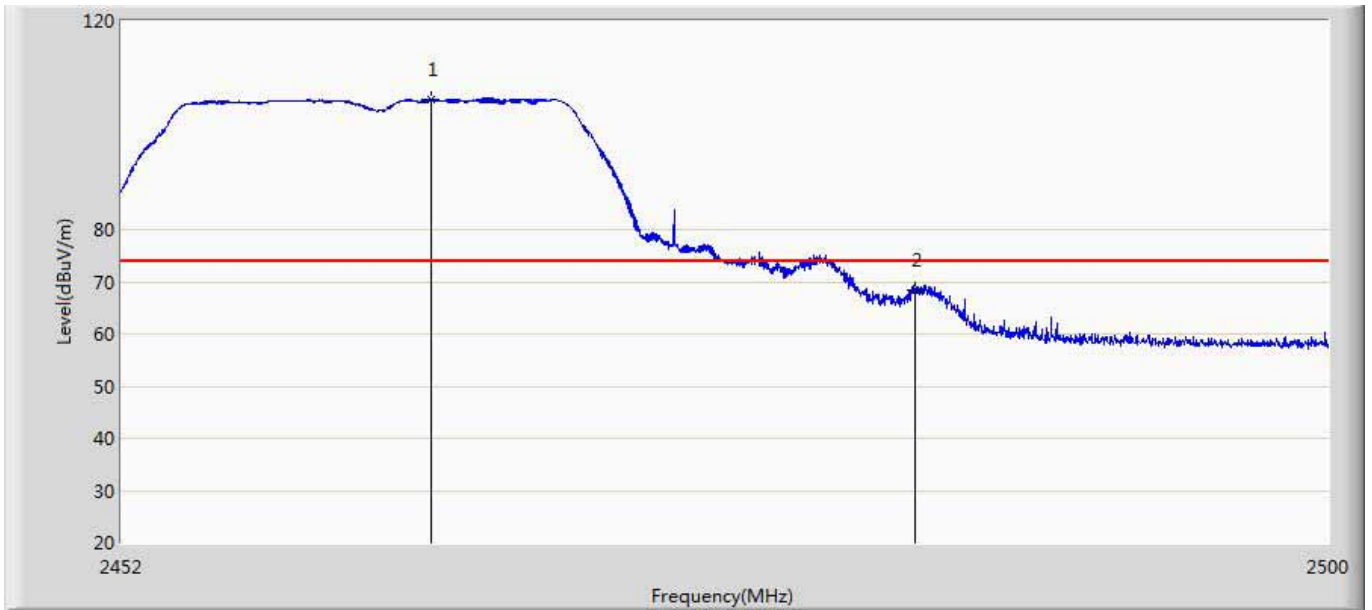

No	Mark	Frequency (MHz)	Measure Level (dBuV/m)	Reading Level (dBuV)	Over Limit (dB)	Limit (dBuV/m)	Factor (dB)	Type
1	*	2464.240	105.019	68.643	31.019	74.000	36.376	PK
2		2483.500	68.417	31.952	-5.583	74.000	36.465	PK

Site: AC5	Time: 2015/06/24 - 13:40
Limit: FCC_Part15.209_RE(3m)	Margin: 0
Probe: Horn_3117_00167055(1-18GHz)	Polarity: Horizontal
EUT: Wi-Fi Module	Power: AC 120V/60Hz
Note: Mode 2 Transmit at 802.11g CH2462 by ant0	

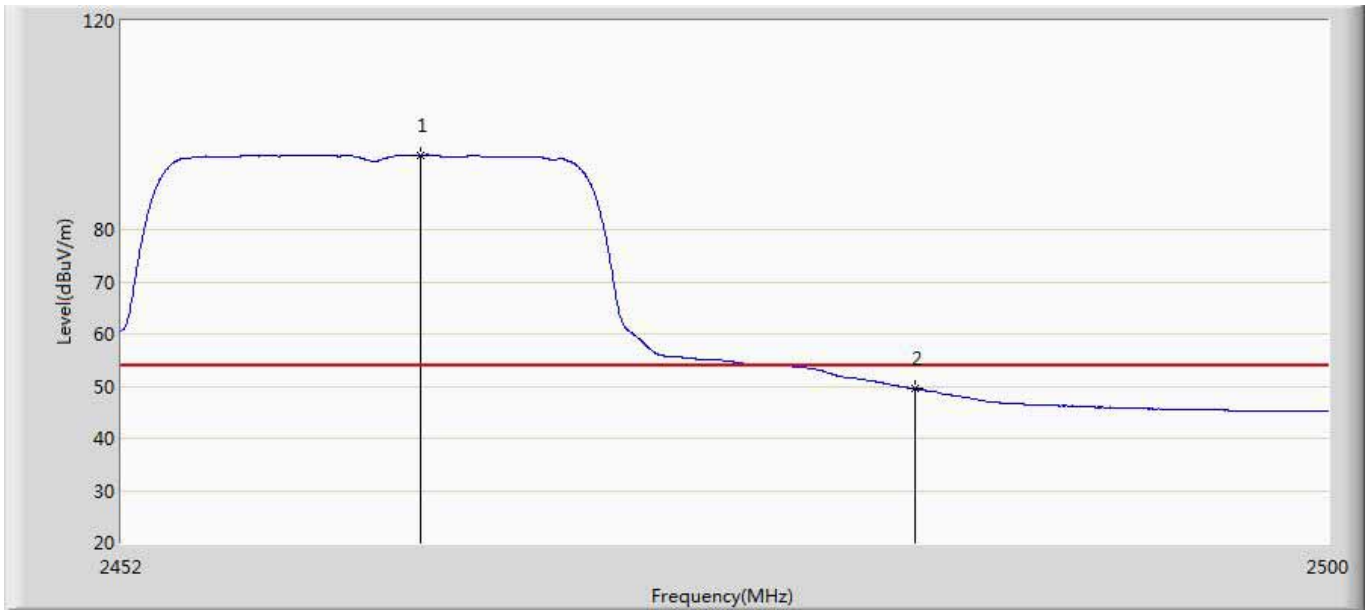

No	Mark	Frequency (MHz)	Measure Level (dBuV/m)	Reading Level (dBuV)	Over Limit (dB)	Limit (dBuV/m)	Factor (dB)	Type
1	*	2463.832	94.292	57.918	40.292	54.000	36.374	AV
2		2483.500	49.473	13.008	-4.527	54.000	36.465	AV

Site: AC5	Time: 2015/06/24 - 13:56
Limit: FCC_Part15.209_RE(3m)	Margin: 0
Probe: Horn_3117_00167055(1-18GHz)	Polarity: Vertical
EUT: Wi-Fi Module	Power: AC 120V/60Hz
Note: Mode 3 Transmit at 802.11n20 CH2412 by ant0	

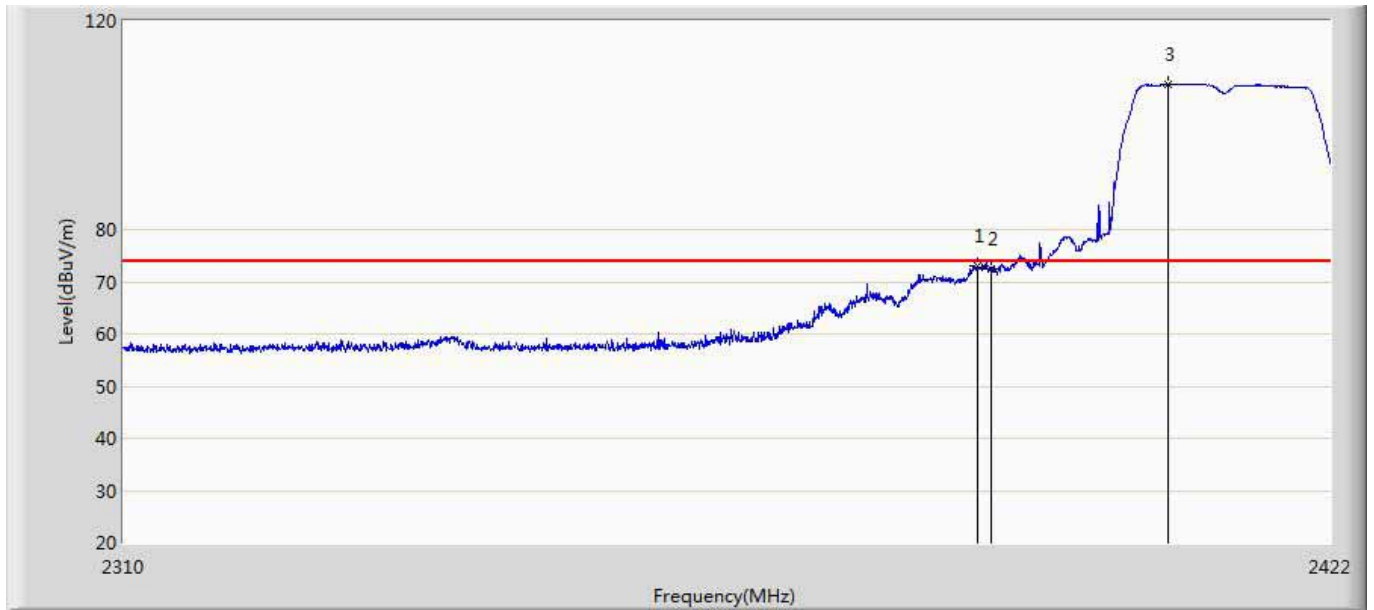

No	Mark	Frequency (MHz)	Measure Level (dBuV/m)	Reading Level (dBuV)	Over Limit (dB)	Limit (dBuV/m)	Factor (dB)	Type
1		2388.792	72.995	36.964	-1.005	74.000	36.030	PK
2		2390.000	72.483	36.447	-1.517	74.000	36.037	PK
3	*	2406.712	107.829	71.715	33.829	74.000	36.113	PK

Site: AC5	Time: 2015/06/24 - 14:00
Limit: FCC_Part15.209_RE(3m)	Margin: 0
Probe: Horn_3117_00167055(1-18GHz)	Polarity: Vertical
EUT: Wi-Fi Module	Power: AC 120V/60Hz
Note: Mode 3 Transmit at 802.11n20 CH2412 by ant0	

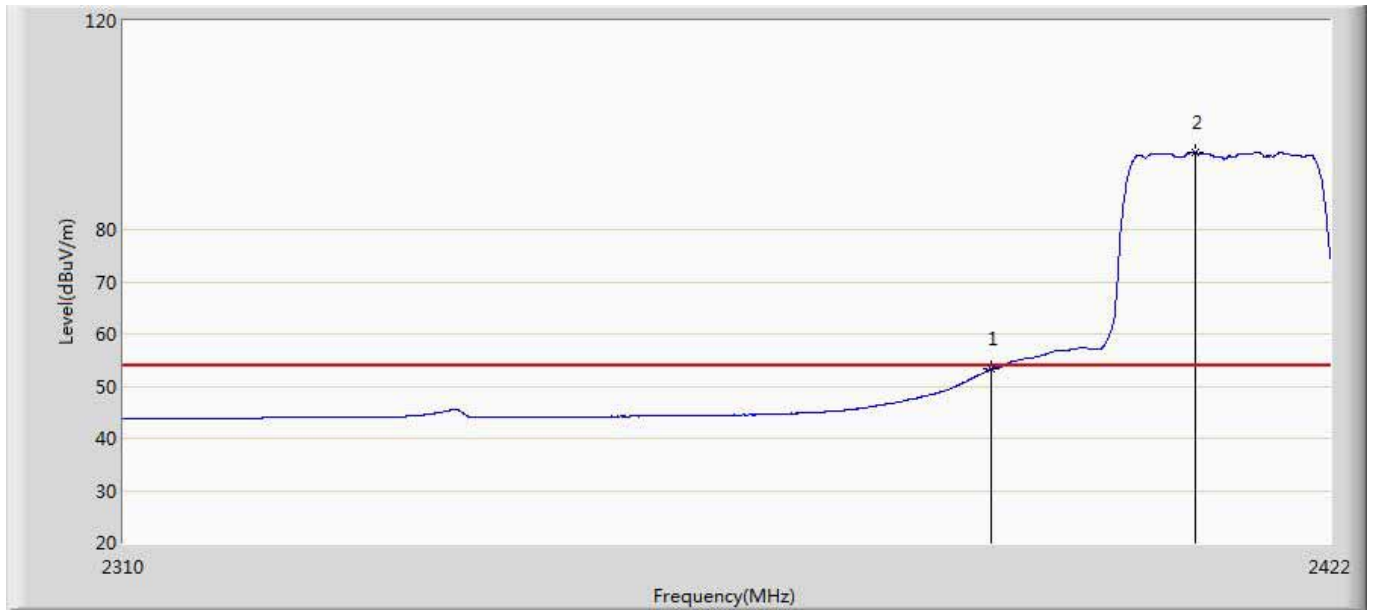

No	Mark	Frequency (MHz)	Measure Level (dBuV/m)	Reading Level (dBuV)	Over Limit (dB)	Limit (dBuV/m)	Factor (dB)	Type
1		2390.000	53.299	17.263	-0.701	54.000	36.037	AV
2	*	2409.232	94.705	58.580	40.705	54.000	36.126	AV

Site: AC5	Time: 2015/06/24 - 14:04
Limit: FCC_Part15.209_RE(3m)	Margin: 0
Probe: Horn_3117_00167055(1-18GHz)	Polarity: Horizontal
EUT: Wi-Fi Module	Power: AC 120V/60Hz
Note: Mode 3 Transmit at 802.11n20 CH2412 by ant0	

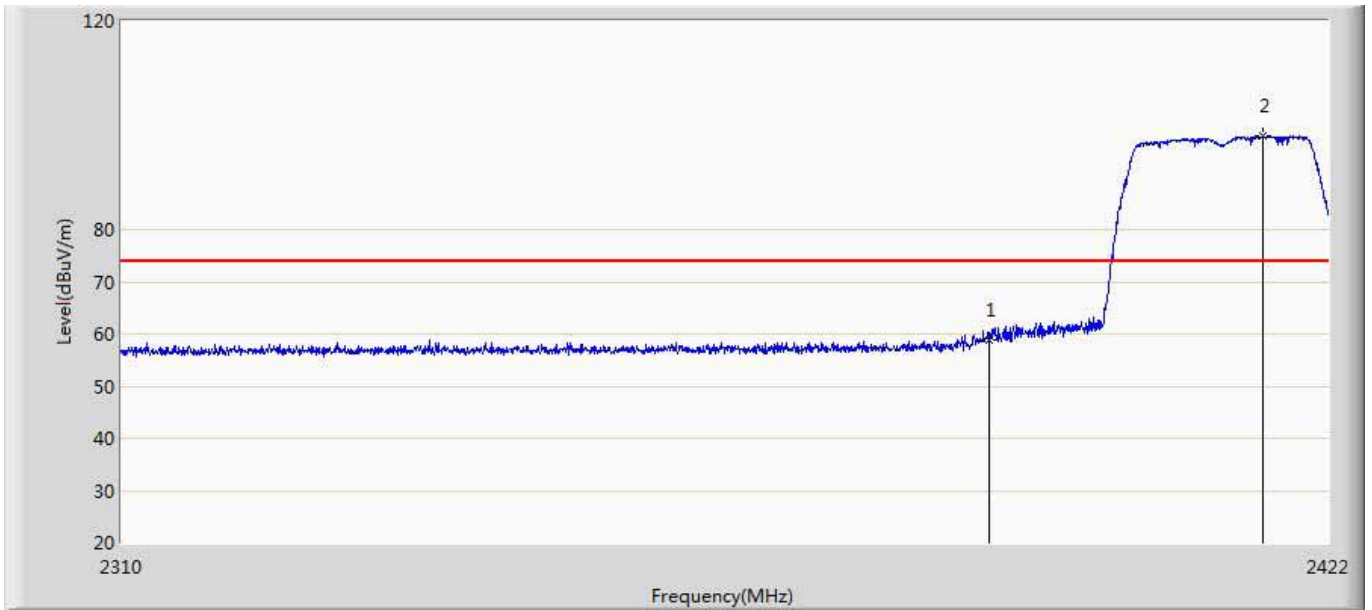

No	Mark	Frequency (MHz)	Measure Level (dBuV/m)	Reading Level (dBuV)	Over Limit (dB)	Limit (dBuV/m)	Factor (dB)	Type
1		2390.000	58.781	22.745	-15.219	74.000	36.037	PK
2	*	2415.896	97.842	61.687	23.842	74.000	36.156	PK

Site: AC5	Time: 2015/06/24 - 14:04
Limit: FCC_Part15.209_RE(3m)	Margin: 0
Probe: Horn_3117_00167055(1-18GHz)	Polarity: Horizontal
EUT: Wi-Fi Module	Power: AC 120V/60Hz
Note: Mode 3 Transmit at 802.11n20 CH2412 by ant0	

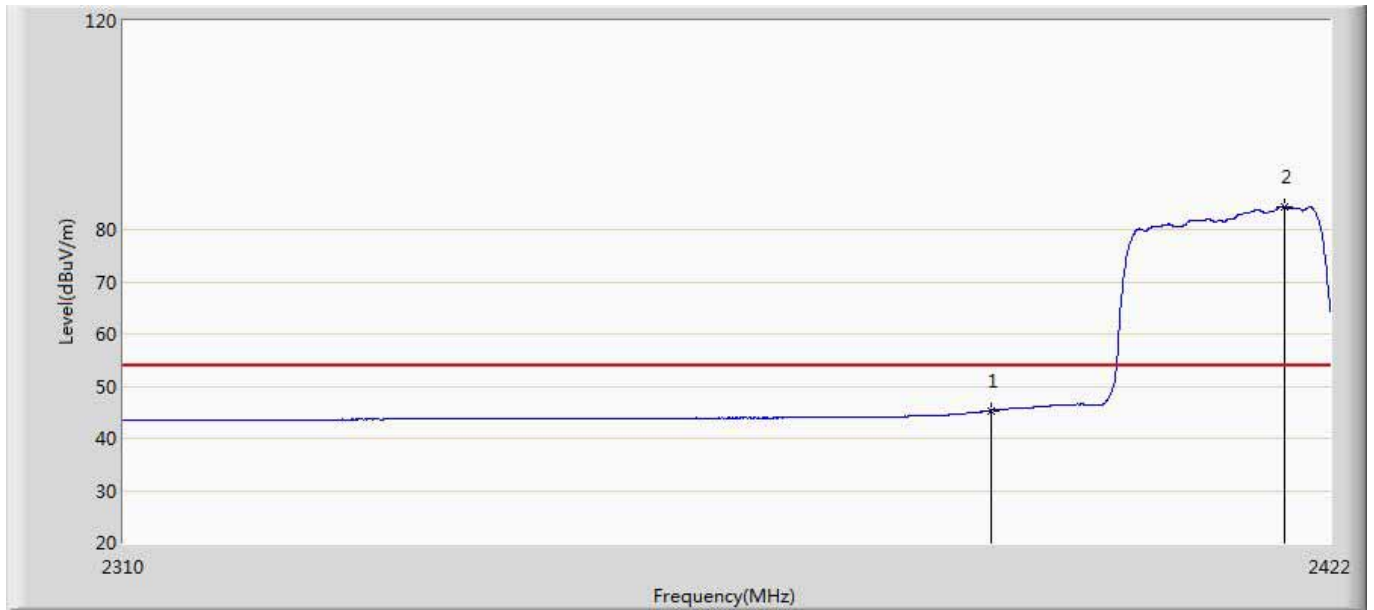

No	Mark	Frequency (MHz)	Measure Level (dBuV/m)	Reading Level (dBuV)	Over Limit (dB)	Limit (dBuV/m)	Factor (dB)	Type
1		2390.000	45.329	9.293	-8.671	54.000	36.037	AV
2	*	2417.632	84.296	48.133	30.296	54.000	36.163	AV

Site: AC5	Time: 2015/06/24 - 14:09
Limit: FCC_Part15.209_RE(3m)	Margin: 0
Probe: Horn_3117_00167055(1-18GHz)	Polarity: Vertical
EUT: Wi-Fi Module	Power: AC 120V/60Hz
Note: Mode 3 Transmit at 802.11n20 CH2462 by ant0	

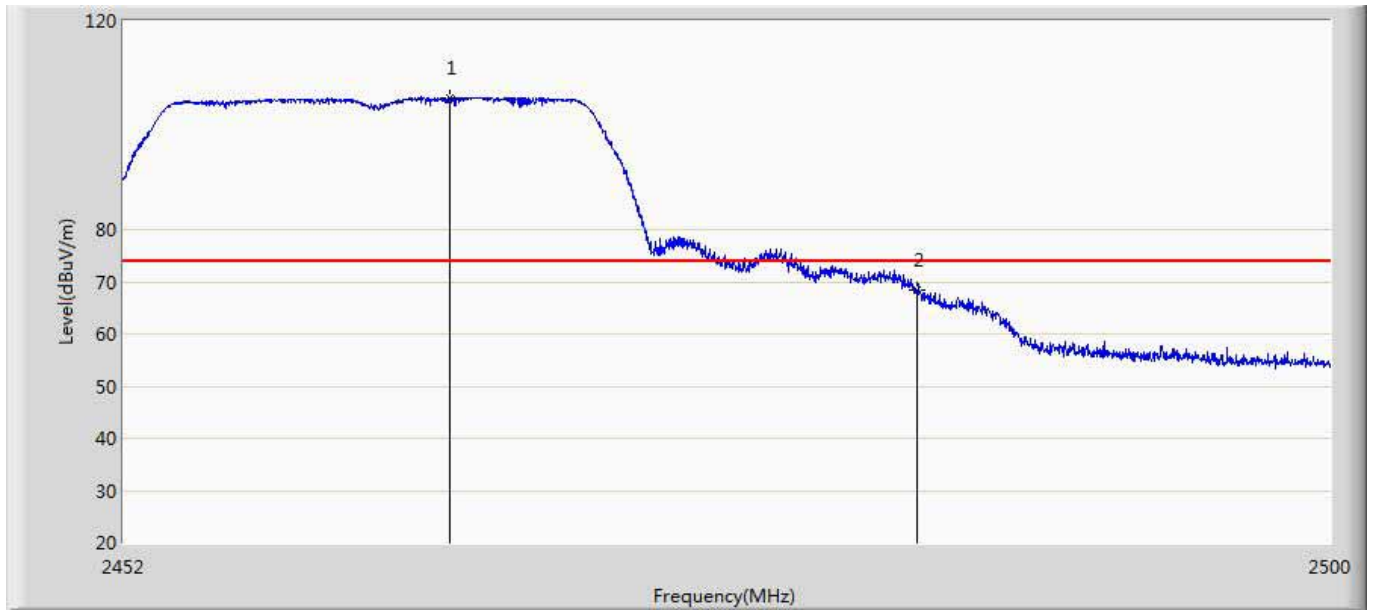

No	Mark	Frequency (MHz)	Measure Level (dBuV/m)	Reading Level (dBuV)	Over Limit (dB)	Limit (dBuV/m)	Factor (dB)	Type
1	*	2464.912	105.254	68.875	31.254	74.000	36.378	PK
2		2483.500	68.482	32.017	-5.518	74.000	36.465	PK

Site: AC5	Time: 2015/06/24 - 14:10
Limit: FCC_Part15.209_RE(3m)	Margin: 0
Probe: Horn_3117_00167055(1-18GHz)	Polarity: Vertical
EUT: Wi-Fi Module	Power: AC 120V/60Hz
Note: Mode 3 Transmit at 802.11n20 CH2462 by ant0	

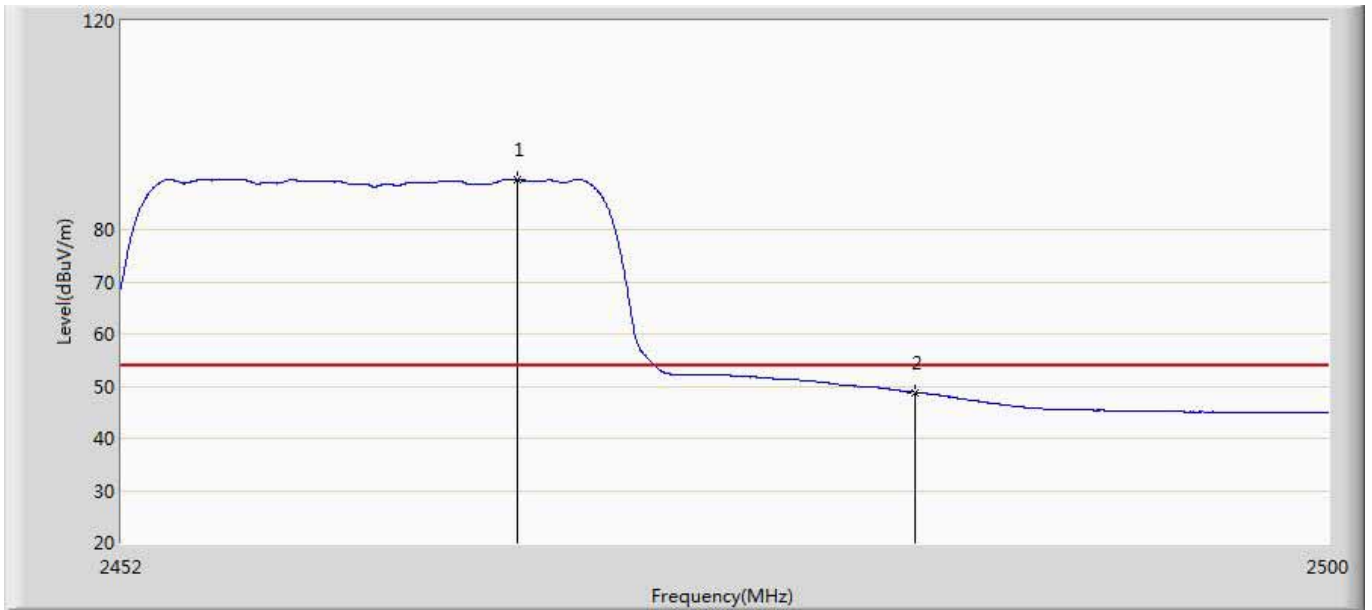

No	Mark	Frequency (MHz)	Measure Level (dBuV/m)	Reading Level (dBuV)	Over Limit (dB)	Limit (dBuV/m)	Factor (dB)	Type
1	*	2467.648	89.485	53.093	35.485	54.000	36.391	AV
2		2483.500	48.827	12.362	-5.173	54.000	36.465	AV

Site: AC5	Time: 2015/06/24 - 14:14
Limit: FCC_Part15.209_RE(3m)	Margin: 0
Probe: Horn_3117_00167055(1-18GHz)	Polarity: Horizontal
EUT: Wi-Fi Module	Power: AC 120V/60Hz
Note: Mode 3 Transmit at 802.11n20 CH2462 by ant0	

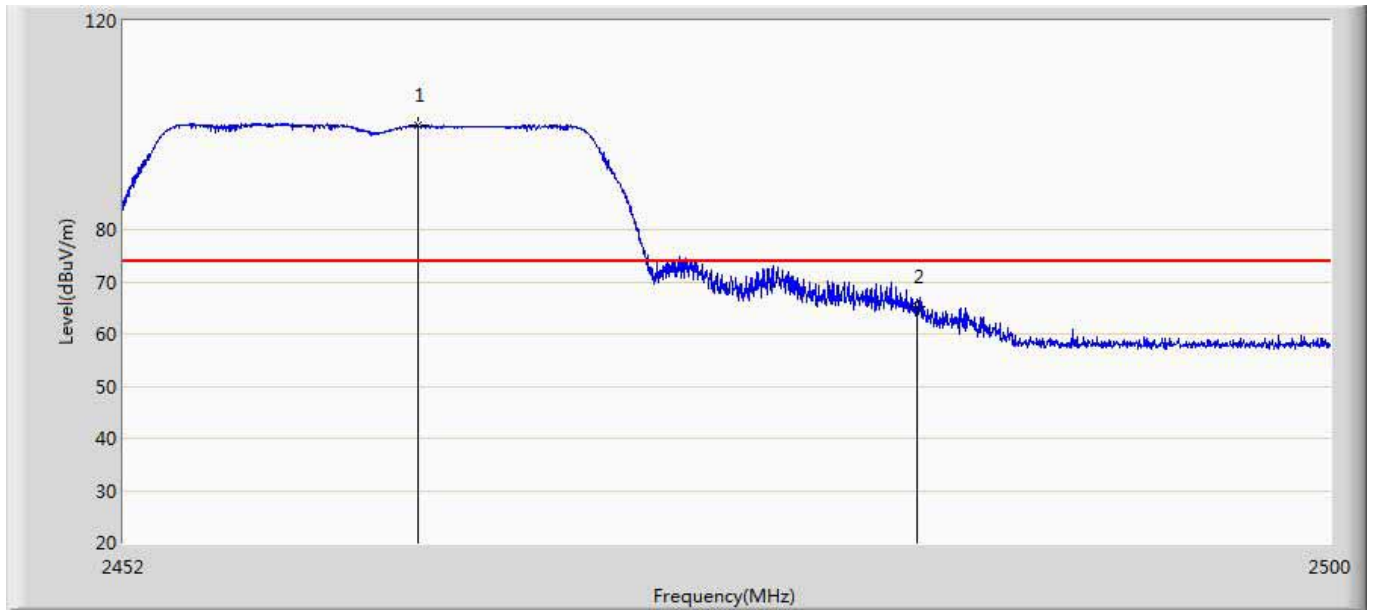

No	Mark	Frequency (MHz)	Measure Level (dBuV/m)	Reading Level (dBuV)	Over Limit (dB)	Limit (dBuV/m)	Factor (dB)	Type
1	*	2463.616	99.995	63.622	25.995	74.000	36.373	PK
2		2483.500	65.102	28.637	-8.898	74.000	36.465	PK

Site: AC5	Time: 2015/06/24 - 14:15
Limit: FCC_Part15.209_RE(3m)	Margin: 0
Probe: Horn_3117_00167055(1-18GHz)	Polarity: Horizontal
EUT: Wi-Fi Module	Power: AC 120V/60Hz
Note: Mode 3 Transmit at 802.11n20 CH2462 by ant0	

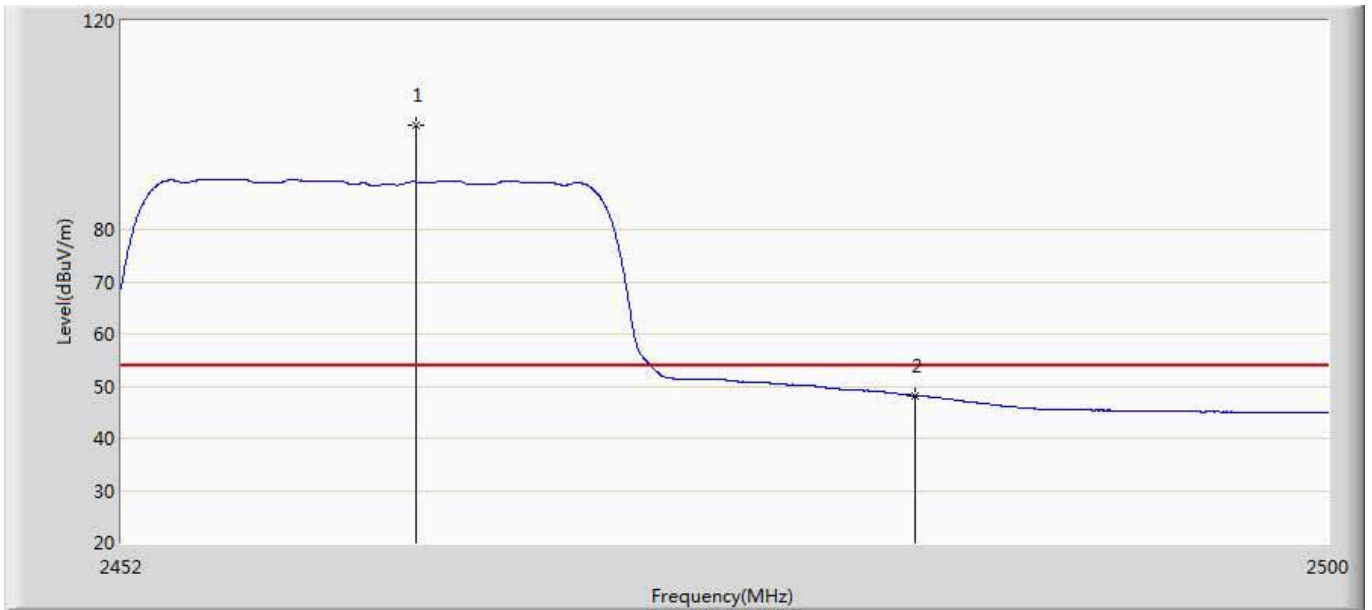

No	Mark	Frequency (MHz)	Measure Level (dBuV/m)	Reading Level (dBuV)	Over Limit (dB)	Limit (dBuV/m)	Factor (dB)	Type
1	*	2463.616	99.995	63.622	45.995	54.000	36.373	AV
2		2483.500	48.202	11.737	-5.798	54.000	36.465	AV

Site: AC5	Time: 2015/06/24 - 14:27
Limit: FCC_Part15.209_RE(3m)	Margin: 0
Probe: Horn_3117_00167055(1-18GHz)	Polarity: Vertical
EUT: Wi-Fi Module	Power: AC 120V/60Hz
Note: Mode 4 Transmit at 802.11n40 CH2422 by ant0	

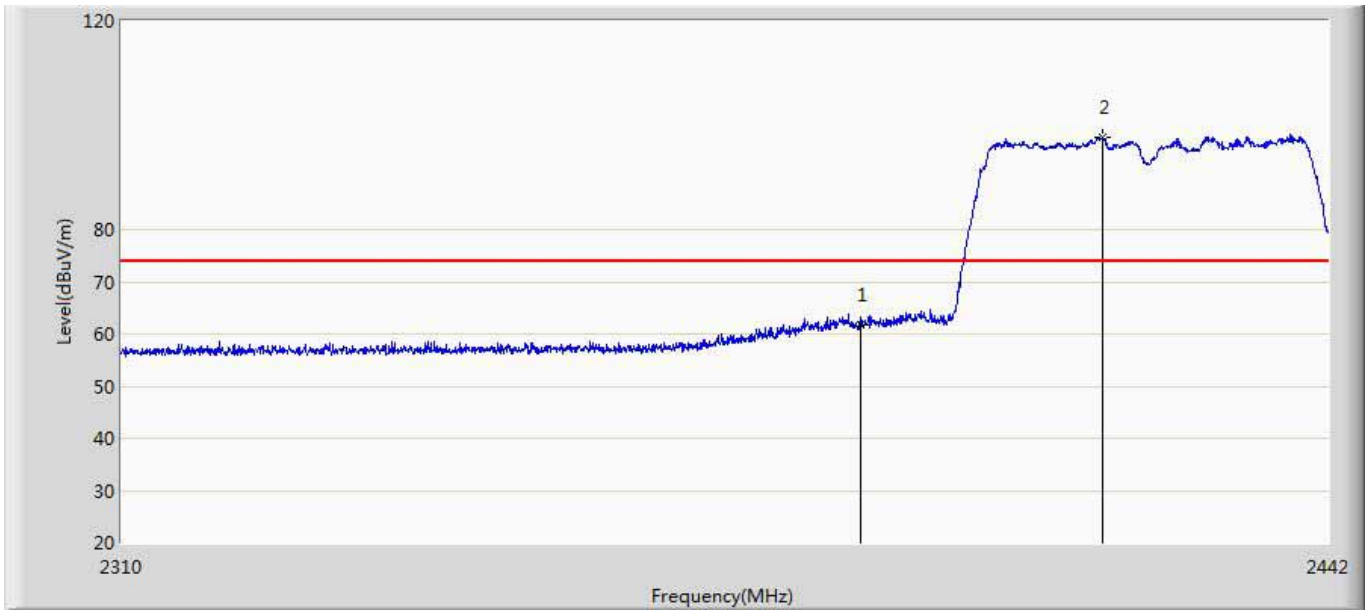

No	Mark	Frequency (MHz)	Measure Level (dBuV/m)	Reading Level (dBuV)	Over Limit (dB)	Limit (dBuV/m)	Factor (dB)	Type
1		2390.000	61.815	25.779	-12.185	74.000	36.037	PK
2	*	2416.722	97.807	61.648	23.807	74.000	36.159	PK

Site: AC5	Time: 2015/06/24 - 14:28
Limit: FCC_Part15.209_RE(3m)	Margin: 0
Probe: Horn_3117_00167055(1-18GHz)	Polarity: Vertical
EUT: Wi-Fi Module	Power: AC 120V/60Hz
Note: Mode 4 Transmit at 802.11n40 CH2422 by ant0	

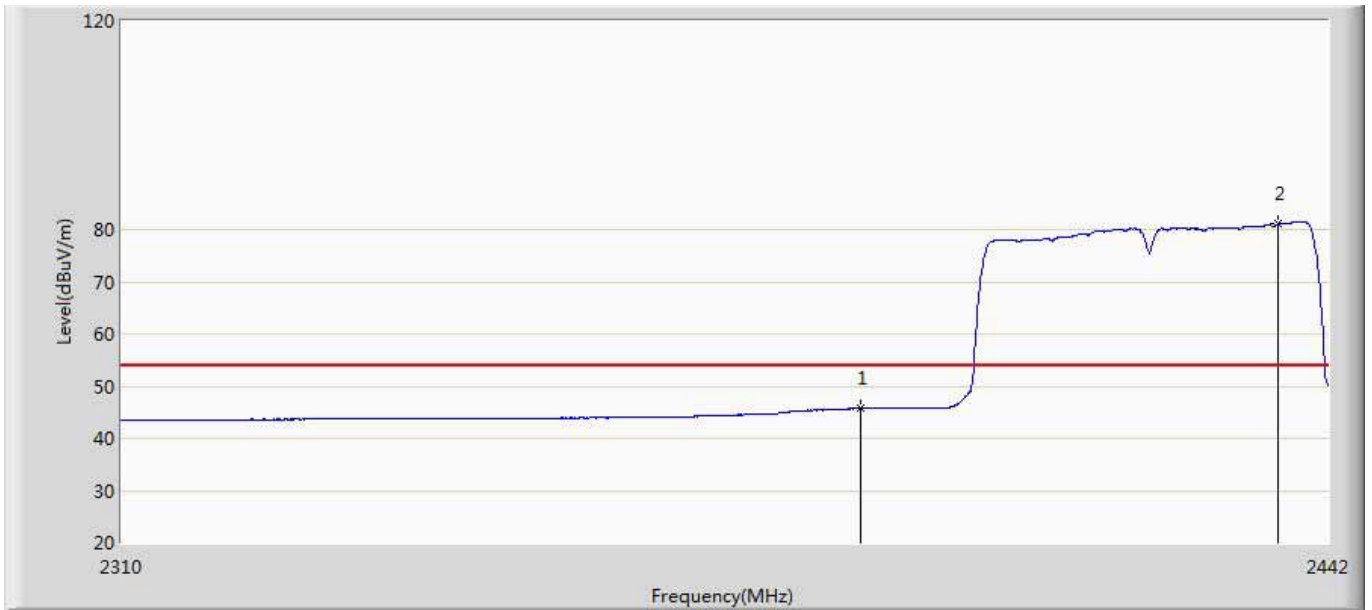

No	Mark	Frequency (MHz)	Measure Level (dBuV/m)	Reading Level (dBuV)	Over Limit (dB)	Limit (dBuV/m)	Factor (dB)	Type
1		2390.000	45.823	9.787	-8.177	54.000	36.037	AV
2	*	2436.390	81.055	44.807	27.055	54.000	36.247	AV

Site: AC5	Time: 2015/06/24 - 14:31
Limit: FCC_Part15.209_RE(3m)	Margin: 0
Probe: Horn_3117_00167055(1-18GHz)	Polarity: Horizontal
EUT: Wi-Fi Module	Power: AC 120V/60Hz
Note: Mode 4 Transmit at 802.11n40 CH2422 by ant0	

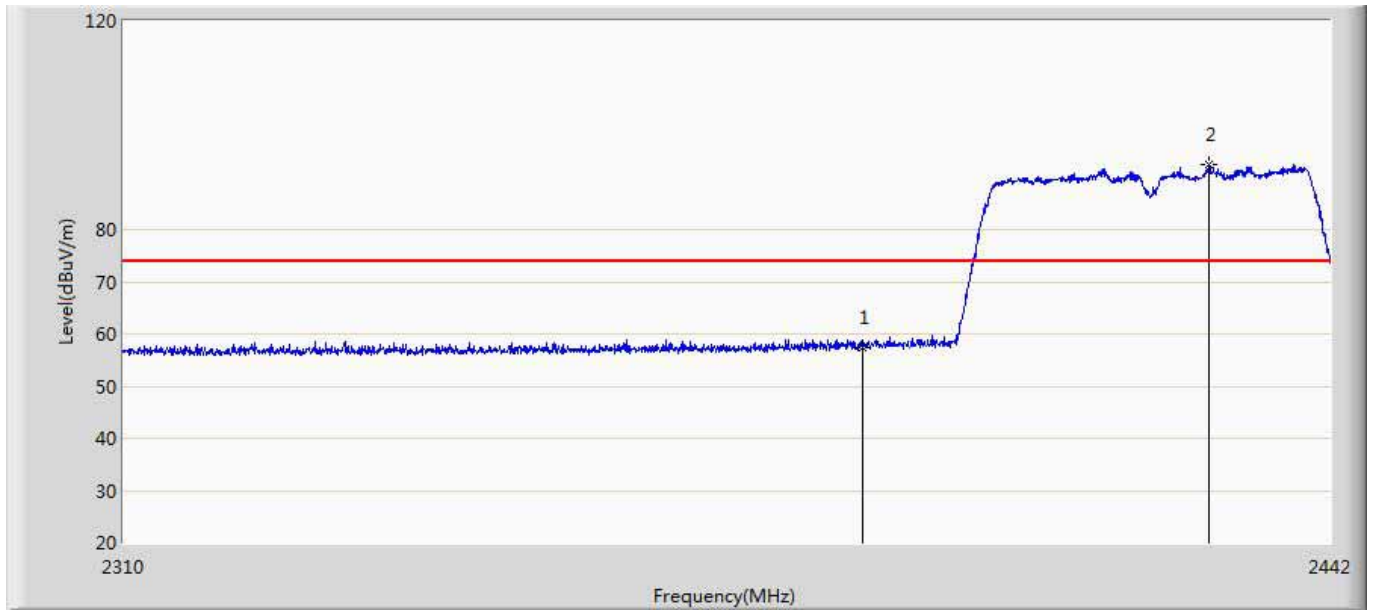

No	Mark	Frequency (MHz)	Measure Level (dBuV/m)	Reading Level (dBuV)	Over Limit (dB)	Limit (dBuV/m)	Factor (dB)	Type
1		2390.000	57.502	21.466	-16.498	74.000	36.037	PK
2	*	2428.470	92.481	56.270	18.481	74.000	36.212	PK

Site: AC5	Time: 2015/06/24 - 14:32
Limit: FCC_Part15.209_RE(3m)	Margin: 0
Probe: Horn_3117_00167055(1-18GHz)	Polarity: Horizontal
EUT: Wi-Fi Module	Power: AC 120V/60Hz
Note: Mode 4 Transmit at 802.11n40 CH2422 by ant0	

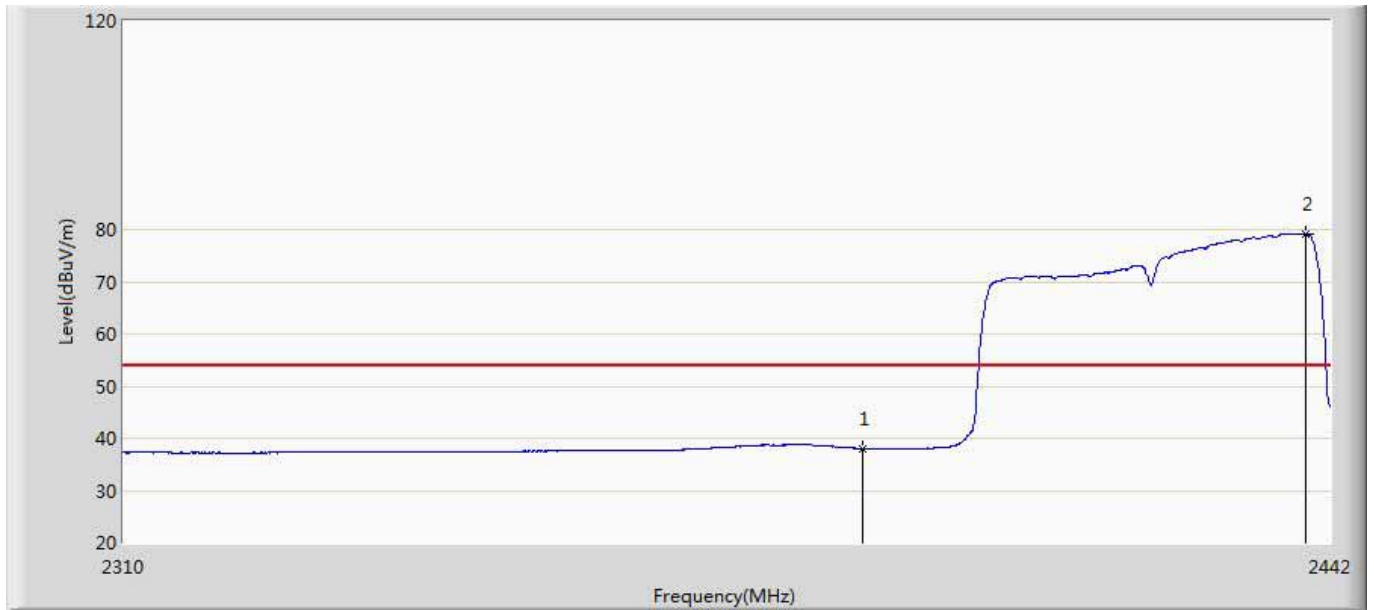

No	Mark	Frequency (MHz)	Measure Level (dBuV/m)	Reading Level (dBuV)	Over Limit (dB)	Limit (dBuV/m)	Factor (dB)	Type
1		2390.000	38.069	2.033	-15.931	54.000	36.037	AV
2	*	2439.360	79.171	42.910	25.171	54.000	36.261	AV

Site: AC5	Time: 2015/06/24 - 14:41
Limit: FCC_Part15.209_RE(3m)	Margin: 0
Probe: Horn_3117_00167055(1-18GHz)	Polarity: Vertical
EUT: Wi-Fi Module	Power: AC 120V/60Hz
Note: Mode 4 Transmit at 802.11n40 CH2452 by ant0	

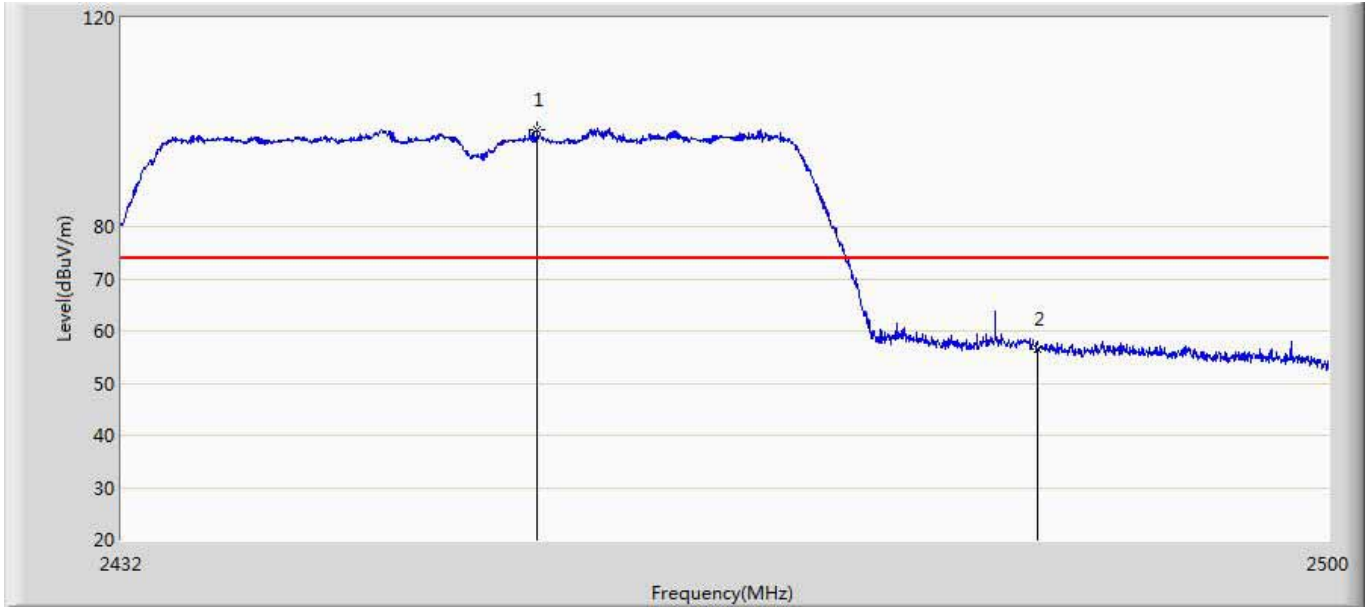

No	Mark	Frequency (MHz)	Measure Level (dBuV/m)	Reading Level (dBuV)	Over Limit (dB)	Limit (dBuV/m)	Factor (dB)	Type
1	*	2455.222	98.430	62.096	24.430	74.000	36.334	PK
2		2483.500	56.465	20.000	-17.535	74.000	36.465	PK

Site: AC5	Time: 2015/06/24 - 14:41
Limit: FCC_Part15.209_RE(3m)	Margin: 0
Probe: Horn_3117_00167055(1-18GHz)	Polarity: Vertical
EUT: Wi-Fi Module	Power: AC 120V/60Hz
Note: Mode 4 Transmit at 802.11n40 CH2452 by ant0	

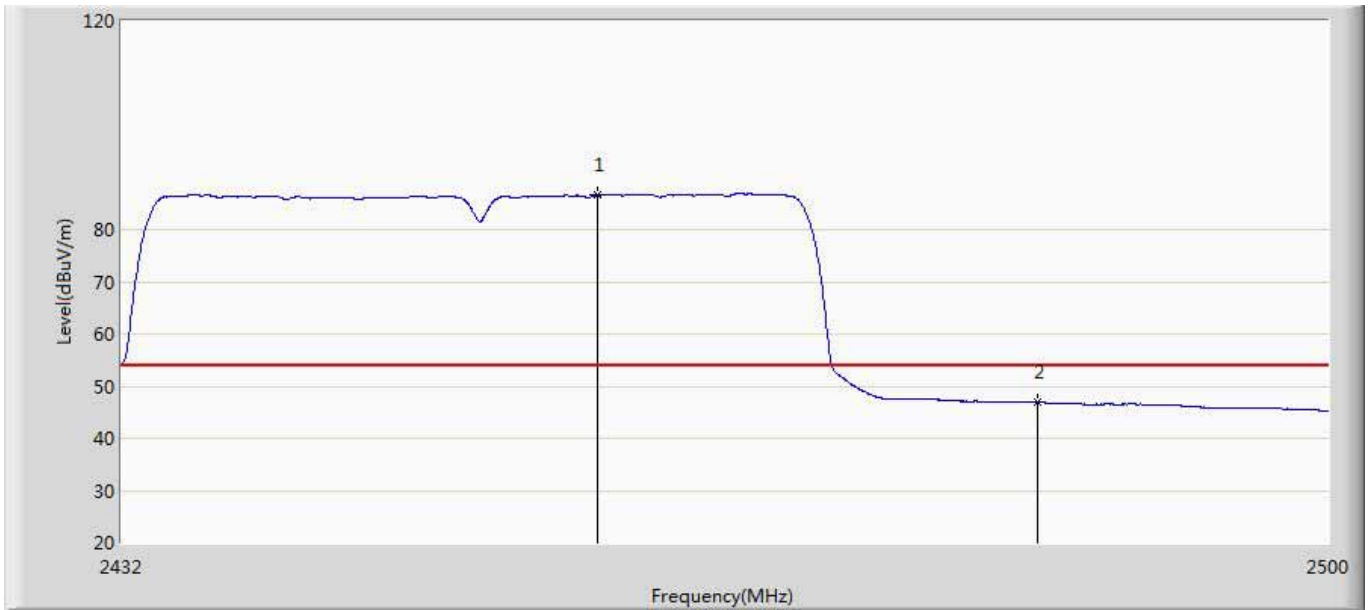

No	Mark	Frequency (MHz)	Measure Level (dBuV/m)	Reading Level (dBuV)	Over Limit (dB)	Limit (dBuV/m)	Factor (dB)	Type
1	*	2458.656	86.628	50.278	32.628	54.000	36.350	AV
2		2483.500	46.942	10.477	-7.058	54.000	36.465	AV

Site: AC5	Time: 2015/06/24 - 14:45
Limit: FCC_Part15.209_RE(3m)	Margin: 0
Probe: Horn_3117_00167055(1-18GHz)	Polarity: Horizontal
EUT: Wi-Fi Module	Power: AC 120V/60Hz
Note: Mode 4 Transmit at 802.11n40 CH2452 by ant0	

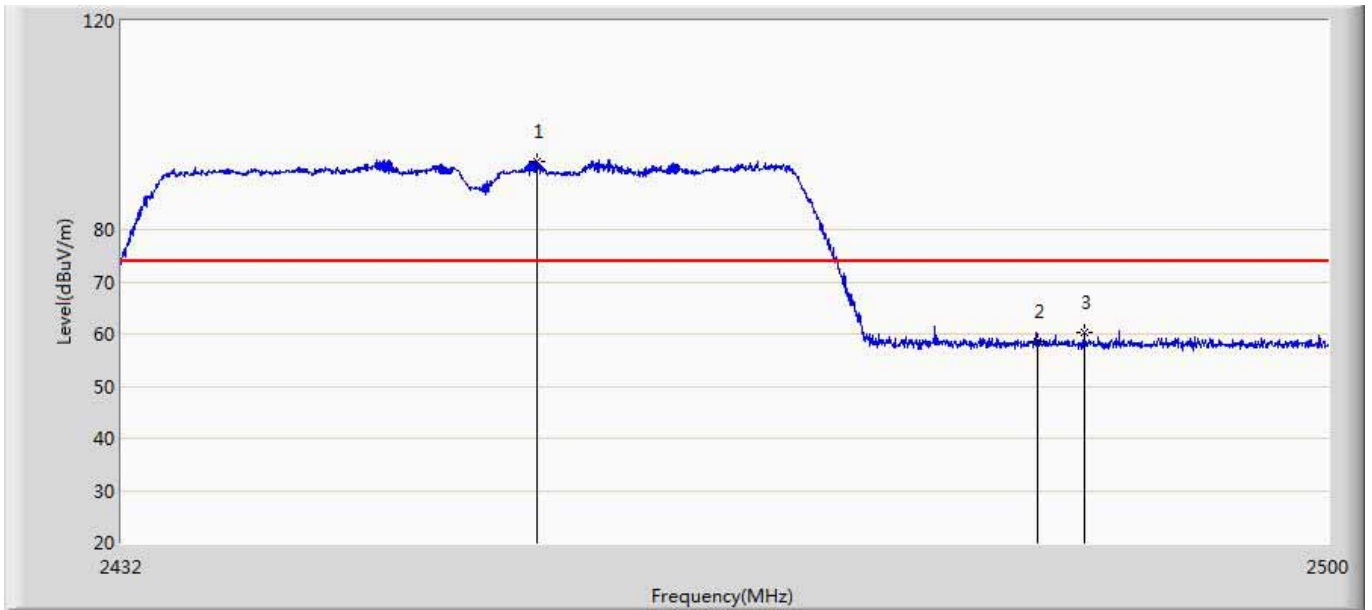

No	Mark	Frequency (MHz)	Measure Level (dBuV/m)	Reading Level (dBuV)	Over Limit (dB)	Limit (dBuV/m)	Factor (dB)	Type
1	*	2455.222	93.096	56.762	19.096	74.000	36.334	PK
2		2483.500	58.553	22.088	-15.447	74.000	36.465	PK
3		2486.094	60.346	23.869	-13.654	74.000	36.477	PK

Site: AC5	Time: 2015/06/24 - 14:46
Limit: FCC_Part15.209_RE(3m)	Margin: 0
Probe: Horn_3117_00167055(1-18GHz)	Polarity: Horizontal
EUT: Wi-Fi Module	Power: AC 120V/60Hz
Note: Mode 4 Transmit at 802.11n40 CH2452 by ant0	

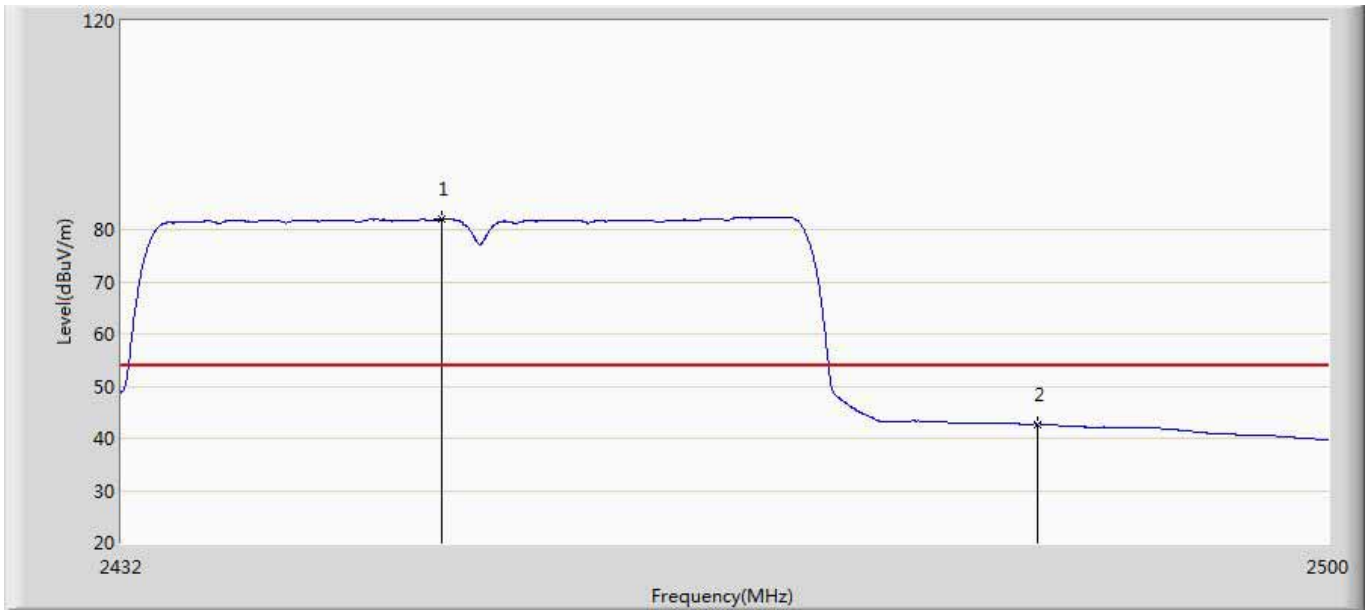

No	Mark	Frequency (MHz)	Measure Level (dBuV/m)	Reading Level (dBuV)	Over Limit (dB)	Limit (dBuV/m)	Factor (dB)	Type
1	*	2449.884	81.988	45.679	27.988	54.000	36.310	AV
2		2483.500	42.734	6.269	-11.266	54.000	36.465	AV

Site: AC5	Time: 2015/06/24 - 14:53
Limit: FCC_Part15.209_RE(3m)	Margin: 0
Probe: Horn_3117_00167055(1-18GHz)	Polarity: Vertical
EUT: Wi-Fi Module	Power: AC 120V/60Hz
Note: Mode 1 Transmit at 802.11b CH2412 by ant1	

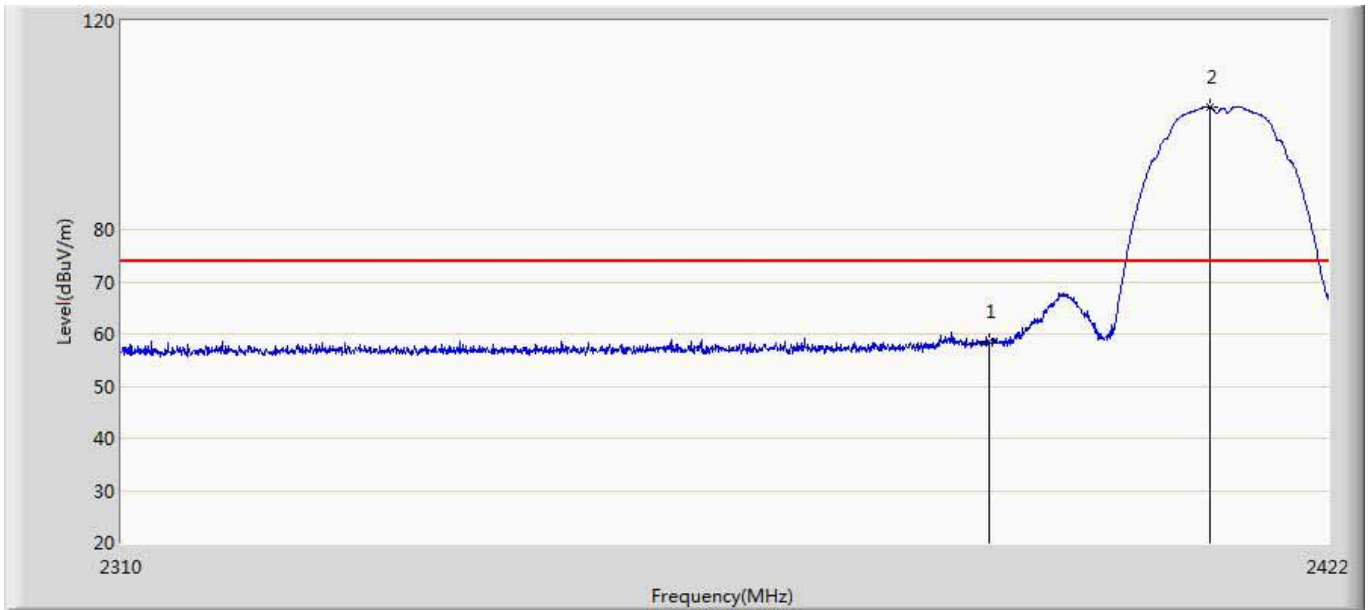

No	Mark	Frequency (MHz)	Measure Level (dBuV/m)	Reading Level (dBuV)	Over Limit (dB)	Limit (dBuV/m)	Factor (dB)	Type
1		2390.000	58.442	22.406	-15.558	74.000	36.037	PK
2	*	2410.856	103.522	67.389	29.522	74.000	36.132	PK

Site: AC5	Time: 2015/06/24 - 14:54
Limit: FCC_Part15.209_RE(3m)	Margin: 0
Probe: Horn_3117_00167055(1-18GHz)	Polarity: Vertical
EUT: Wi-Fi Module	Power: AC 120V/60Hz
Note: Mode 1 Transmit at 802.11b CH2412 by ant1	

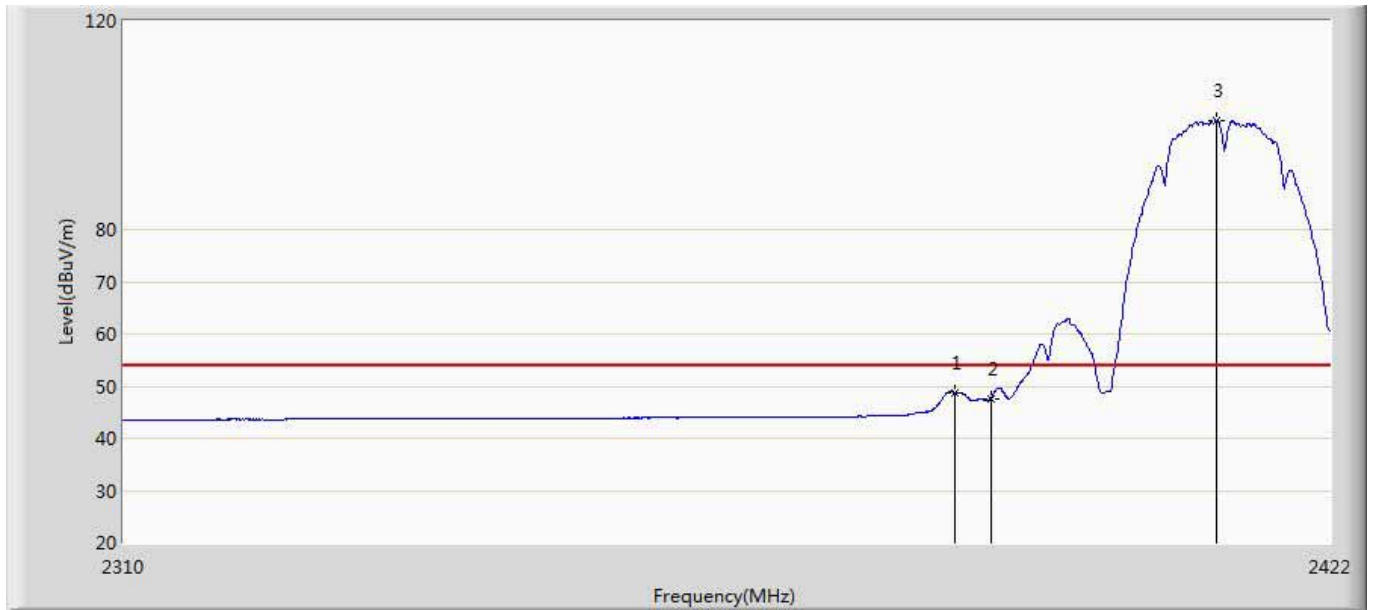

No	Mark	Frequency (MHz)	Measure Level (dBuV/m)	Reading Level (dBuV)	Over Limit (dB)	Limit (dBuV/m)	Factor (dB)	Type
1		2386.664	48.786	12.765	-5.214	54.000	36.021	AV
2		2390.000	47.673	11.637	-6.327	54.000	36.037	AV
3	*	2411.248	100.914	64.779	46.914	54.000	36.135	AV

Site: AC5	Time: 2015/06/24 - 14:58
Limit: FCC_Part15.209_RE(3m)	Margin: 0
Probe: Horn_3117_00167055(1-18GHz)	Polarity: Horizontal
EUT: Wi-Fi Module	Power: AC 120V/60Hz
Note: Mode 1 Transmit at 802.11b CH2412 by ant1	

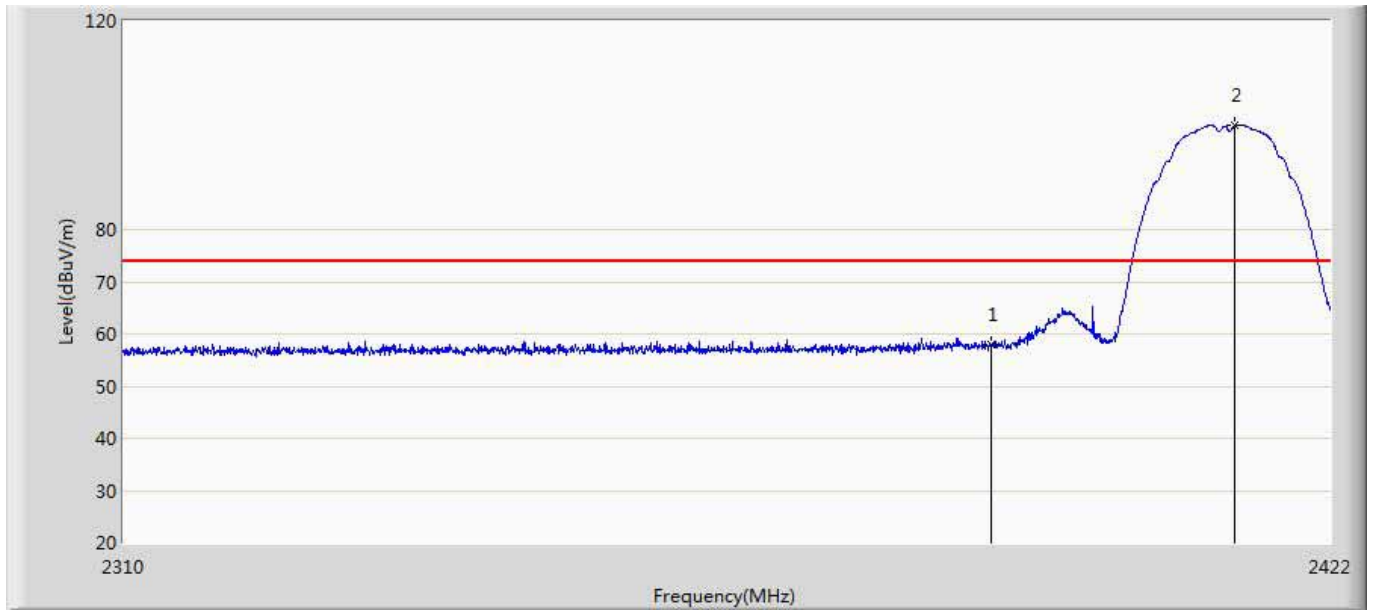

No	Mark	Frequency (MHz)	Measure Level (dBuV/m)	Reading Level (dBuV)	Over Limit (dB)	Limit (dBuV/m)	Factor (dB)	Type
1		2390.000	57.880	21.844	-16.120	74.000	36.037	PK
2	*	2412.984	99.910	63.768	25.910	74.000	36.142	PK

Site: AC5	Time: 2015/06/24 - 14:59
Limit: FCC_Part15.209_RE(3m)	Margin: 0
Probe: Horn_3117_00167055(1-18GHz)	Polarity: Horizontal
EUT: Wi-Fi Module	Power: AC 120V/60Hz
Note: Mode 1 Transmit at 802.11b CH2412 by ant1	

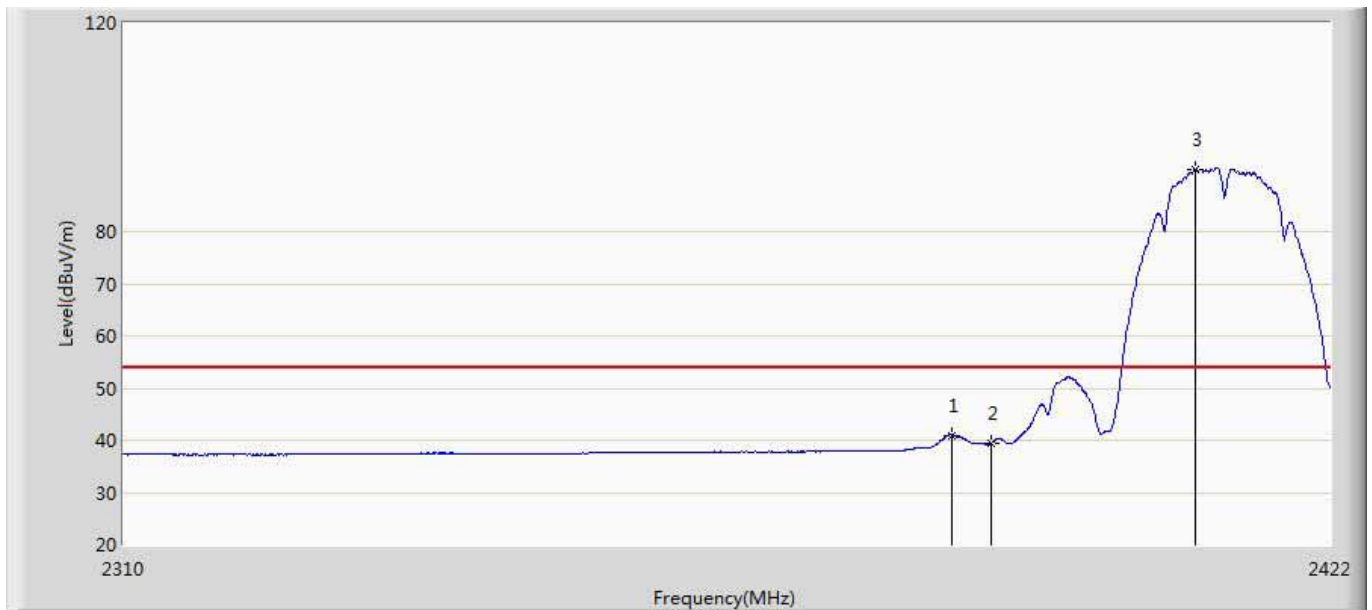

No	Mark	Frequency (MHz)	Measure Level (dBuV/m)	Reading Level (dBuV)	Over Limit (dB)	Limit (dBuV/m)	Factor (dB)	Type
1		2386.328	41.004	4.985	-12.996	54.000	36.019	AV
2		2390.000	39.435	3.399	-14.565	54.000	36.037	AV
3	*	2409.232	91.949	55.824	37.949	54.000	36.126	AV

Site: AC5	Time: 2015/06/24 - 15:05
Limit: FCC_Part15.209_RE(3m)	Margin: 0
Probe: Horn_3117_00167055(1-18GHz)	Polarity: Vertical
EUT: Wi-Fi Module	Power: AC 120V/60Hz
Note: Mode 1 Transmit at 802.11b CH2462 by ant1	

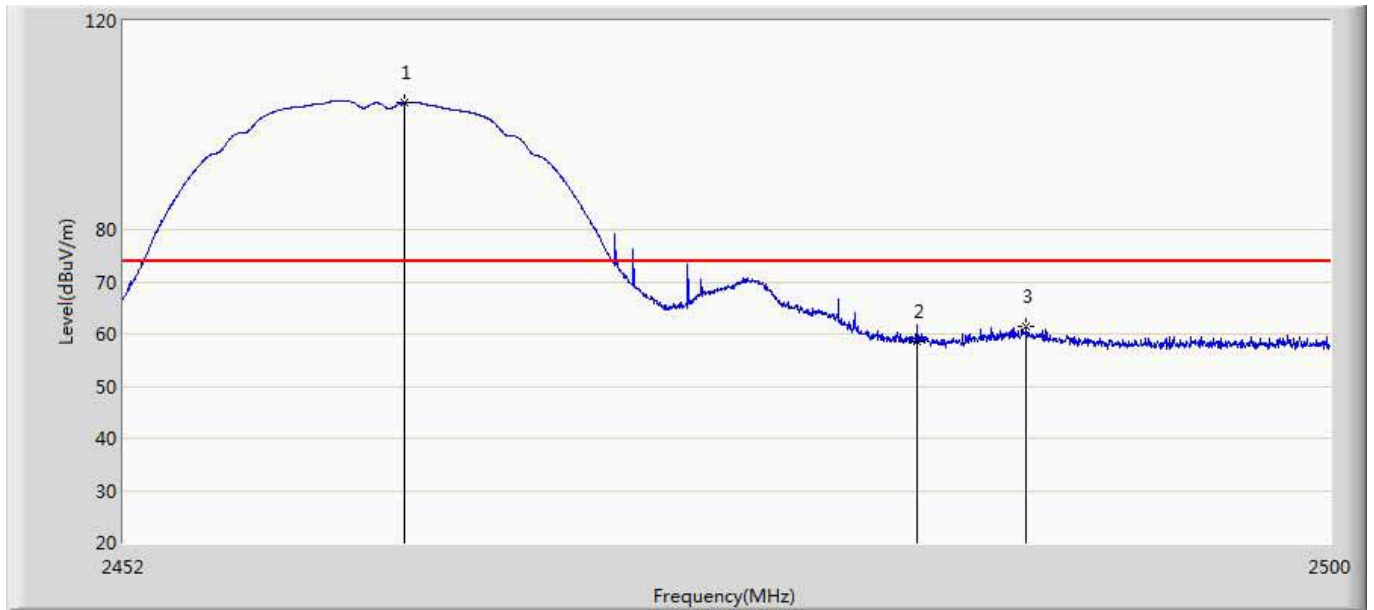

No	Mark	Frequency (MHz)	Measure Level (dBuV/m)	Reading Level (dBuV)	Over Limit (dB)	Limit (dBuV/m)	Factor (dB)	Type
1	*	2463.088	104.323	67.953	30.323	74.000	36.370	PK
2		2483.500	58.604	22.139	-15.396	74.000	36.465	PK
3		2487.832	61.521	25.036	-12.479	74.000	36.485	PK

Site: AC5	Time: 2015/06/24 - 15:06
Limit: FCC_Part15.209_RE(3m)	Margin: 0
Probe: Horn_3117_00167055(1-18GHz)	Polarity: Vertical
EUT: Wi-Fi Module	Power: AC 120V/60Hz
Note: Mode 1 Transmit at 802.11b CH2462 by ant1	

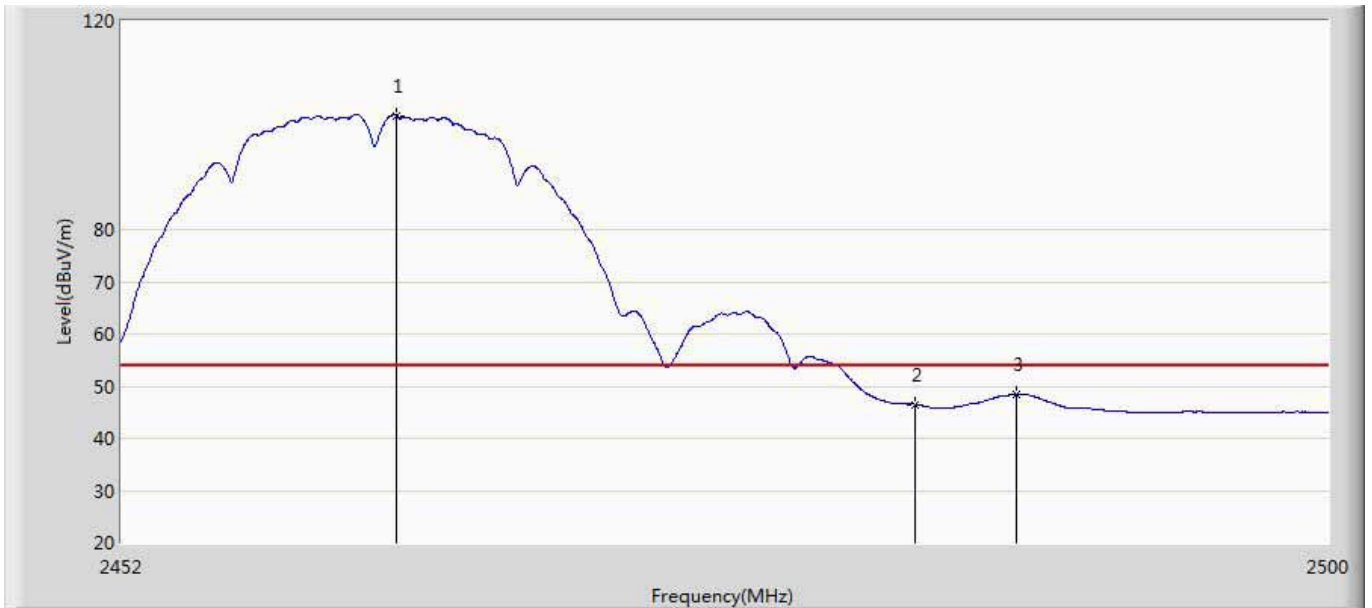

No	Mark	Frequency (MHz)	Measure Level (dBuV/m)	Reading Level (dBuV)	Over Limit (dB)	Limit (dBuV/m)	Factor (dB)	Type
1	*	2462.872	101.859	65.490	47.859	54.000	36.369	AV
2		2483.500	46.445	9.980	-7.555	54.000	36.465	AV
3		2487.544	48.428	11.944	-5.572	54.000	36.484	AV

Site: AC5	Time: 2015/06/24 - 15:09
Limit: FCC_Part15.209_RE(3m)	Margin: 0
Probe: Horn_3117_00167055(1-18GHz)	Polarity: Horizontal
EUT: Wi-Fi Module	Power: AC 120V/60Hz
Note: Mode 1 Transmit at 802.11b CH2462 by ant1	

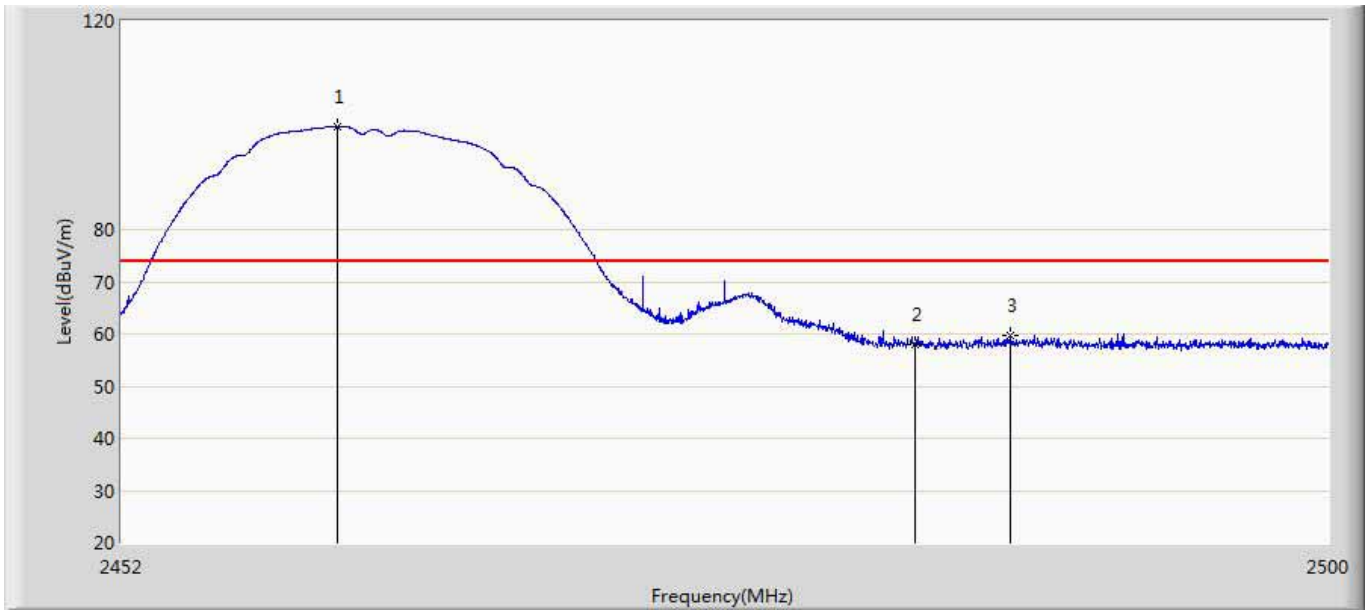

No	Mark	Frequency (MHz)	Measure Level (dBuV/m)	Reading Level (dBuV)	Over Limit (dB)	Limit (dBuV/m)	Factor (dB)	Type
1	*	2460.544	99.806	63.448	25.806	74.000	36.359	PK
2		2483.500	57.906	21.441	-16.094	74.000	36.465	PK
3		2487.304	59.697	23.214	-14.303	74.000	36.483	PK

Site: AC5	Time: 2015/06/24 - 15:10
Limit: FCC_Part15.209_RE(3m)	Margin: 0
Probe: Horn_3117_00167055(1-18GHz)	Polarity: Vertical
EUT: Wi-Fi Module	Power: AC 120V/60Hz
Note: Mode 1 Transmit at 802.11b CH2462 by ant1	

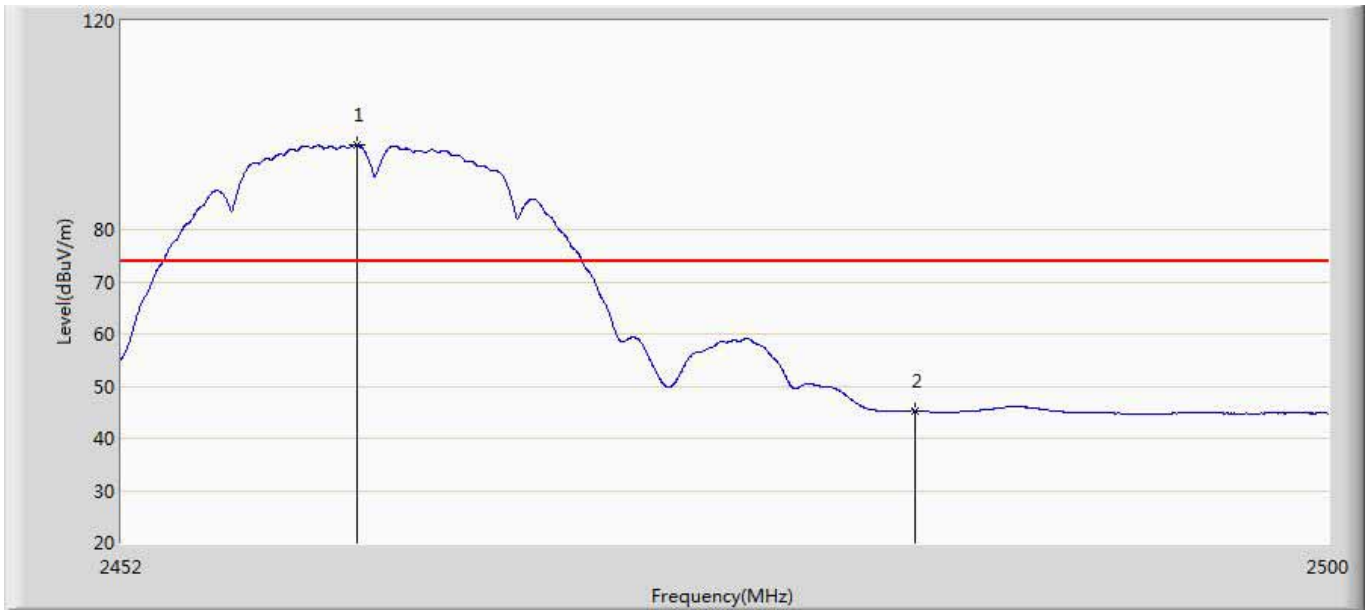

No	Mark	Frequency (MHz)	Measure Level (dBuV/m)	Reading Level (dBuV)	Over Limit (dB)	Limit (dBuV/m)	Factor (dB)	Type
1	*	2461.288	96.295	59.933	22.295	74.000	36.361	PK
2		2483.500	45.323	8.858	-28.677	74.000	36.465	PK

Site: AC5	Time: 2015/06/24 - 15:15
Limit: FCC_Part15.209_RE(3m)	Margin: 0
Probe: Horn_3117_00167055(1-18GHz)	Polarity: Vertical
EUT: Wi-Fi Module	Power: AC 120V/60Hz
Note: Mode 2 Transmit at 802.11g CH2412 by ant1	

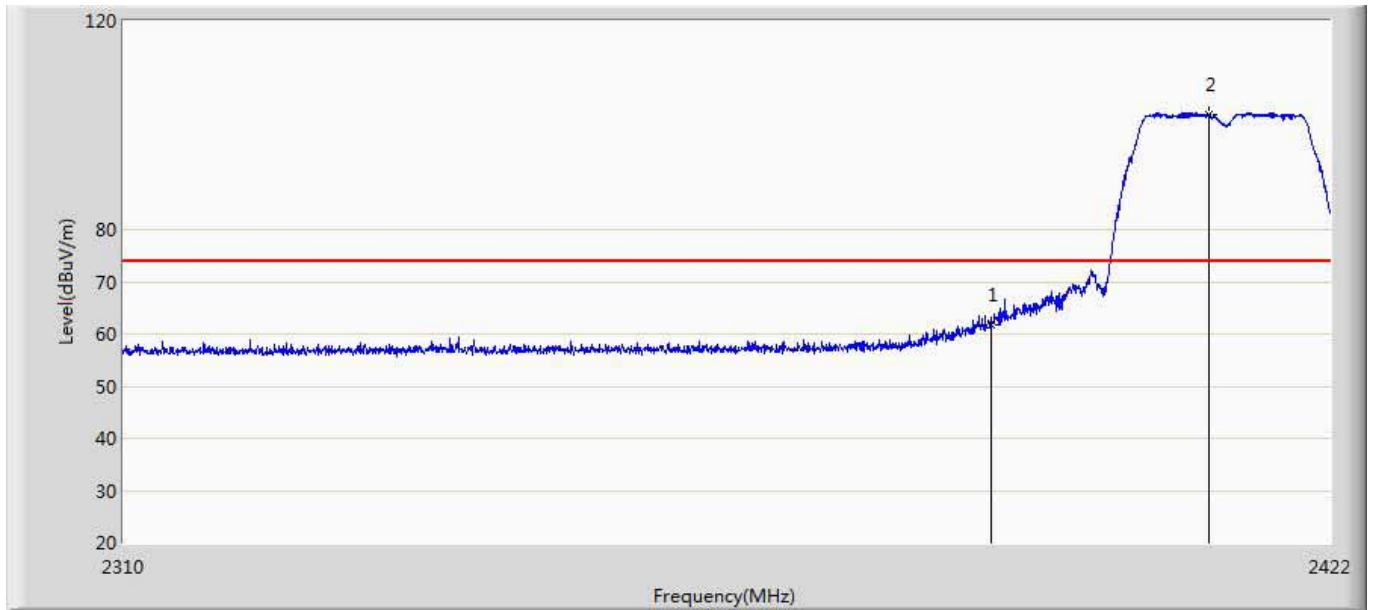

No	Mark	Frequency (MHz)	Measure Level (dBuV/m)	Reading Level (dBuV)	Over Limit (dB)	Limit (dBuV/m)	Factor (dB)	Type
1		2390.000	61.685	25.649	-12.315	74.000	36.037	PK
2	*	2410.520	102.164	66.033	28.164	74.000	36.131	PK

Site: AC5	Time: 2015/06/24 - 15:16
Limit: FCC_Part15.209_RE(3m)	Margin: 0
Probe: Horn_3117_00167055(1-18GHz)	Polarity: Vertical
EUT: Wi-Fi Module	Power: AC 120V/60Hz
Note: Mode 2 Transmit at 802.11g CH2412 by ant1	

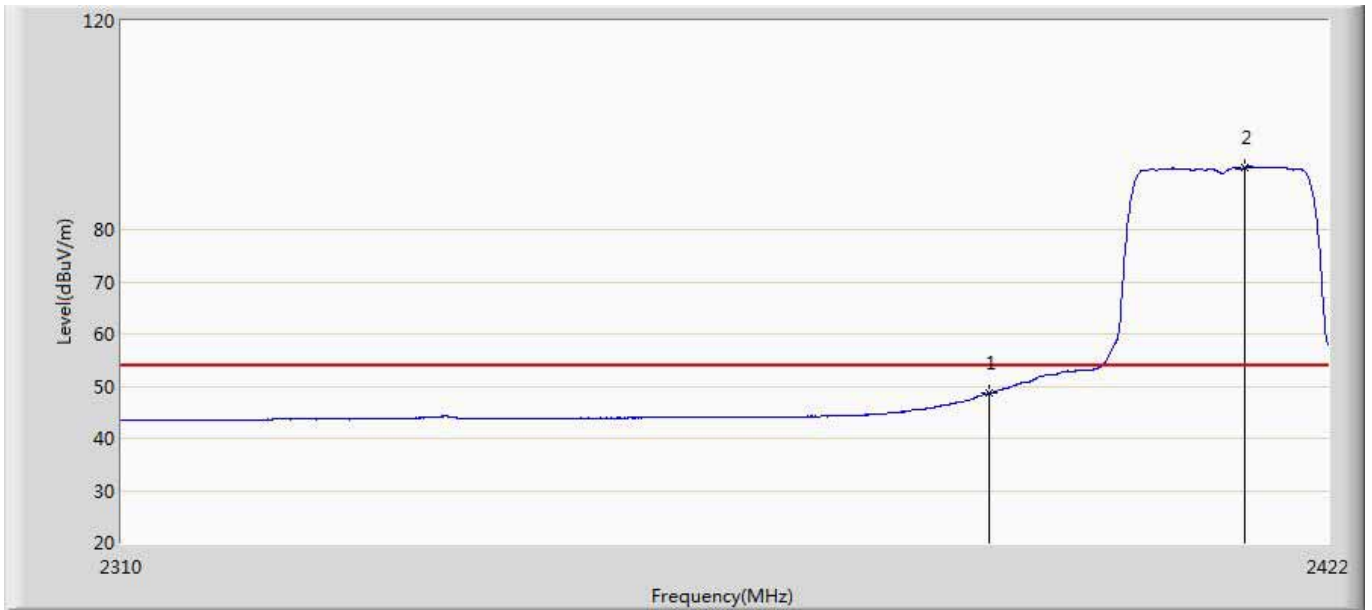

No	Mark	Frequency (MHz)	Measure Level (dBuV/m)	Reading Level (dBuV)	Over Limit (dB)	Limit (dBuV/m)	Factor (dB)	Type
1		2390.000	48.614	12.578	-5.386	54.000	36.037	AV
2	*	2414.160	91.904	55.756	37.904	54.000	36.147	AV

Site: AC5	Time: 2015/06/24 - 15:20
Limit: FCC_Part15.209_RE(3m)	Margin: 0
Probe: Horn_3117_00167055(1-18GHz)	Polarity: Horizontal
EUT: Wi-Fi Module	Power: AC 120V/60Hz
Note: Mode 2 Transmit at 802.11g CH2412 by ant1	

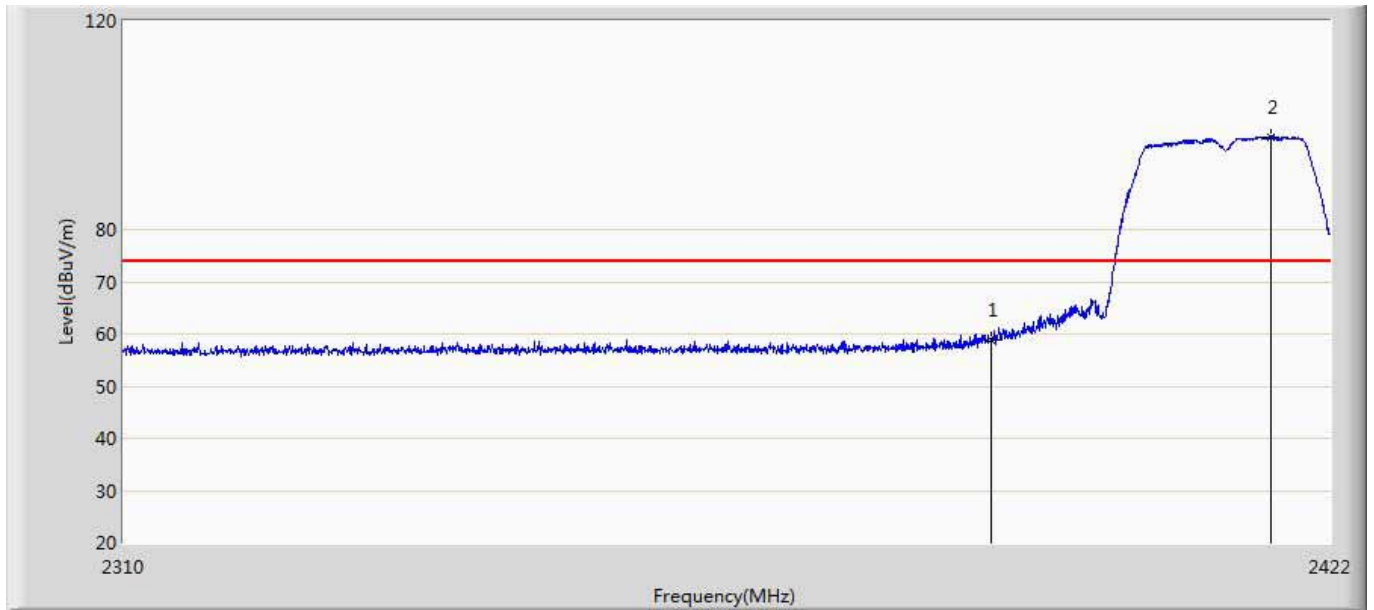

No	Mark	Frequency (MHz)	Measure Level (dBuV/m)	Reading Level (dBuV)	Over Limit (dB)	Limit (dBuV/m)	Factor (dB)	Type
1		2390.000	58.788	22.752	-15.212	74.000	36.037	PK
2	*	2416.400	97.826	61.669	23.826	74.000	36.157	PK

Site: AC5	Time: 2015/06/24 - 15:20
Limit: FCC_Part15.209_RE(3m)	Margin: 0
Probe: Horn_3117_00167055(1-18GHz)	Polarity: Horizontal
EUT: Wi-Fi Module	Power: AC 120V/60Hz
Note: Mode 2 Transmit at 802.11g CH2412 by ant1	

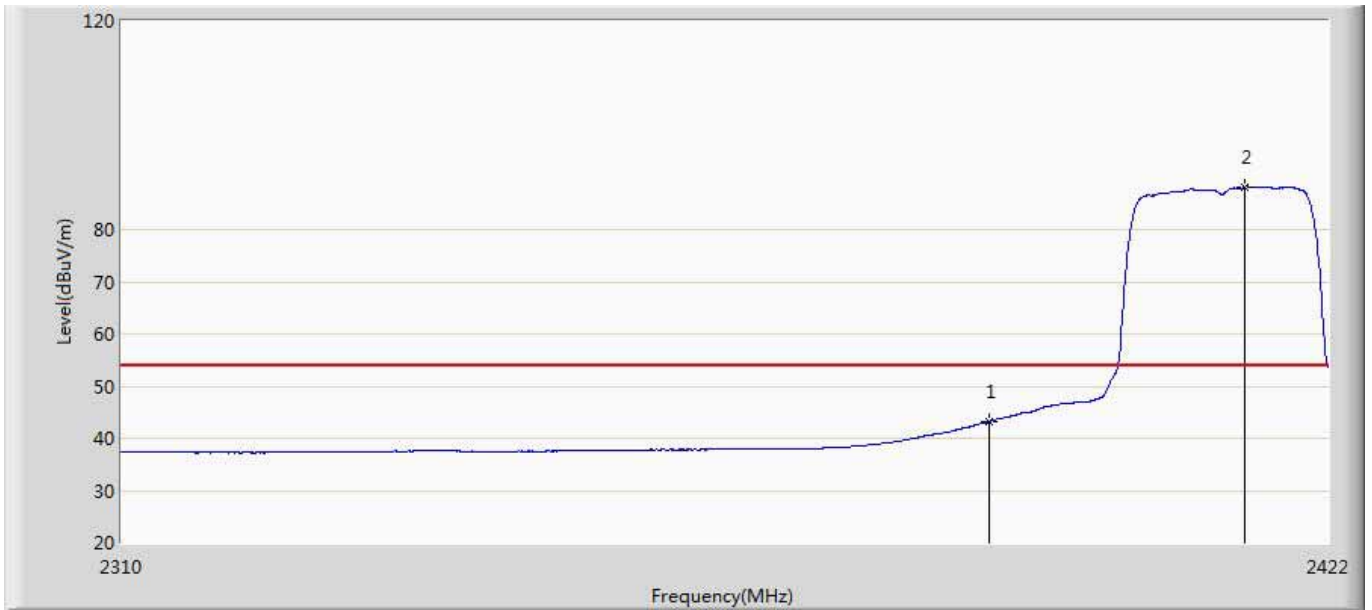

No	Mark	Frequency (MHz)	Measure Level (dBuV/m)	Reading Level (dBuV)	Over Limit (dB)	Limit (dBuV/m)	Factor (dB)	Type
1		2390.000	43.199	7.163	-10.801	54.000	36.037	AV
2	*	2414.048	88.207	52.060	34.207	54.000	36.147	AV

Site: AC5	Time: 2015/06/24 - 15:25
Limit: FCC_Part15.209_RE(3m)	Margin: 0
Probe: Horn_3117_00167055(1-18GHz)	Polarity: Vertical
EUT: Wi-Fi Module	Power: AC 120V/60Hz
Note: Mode 2 Transmit at 802.11g CH2462 by ant1	

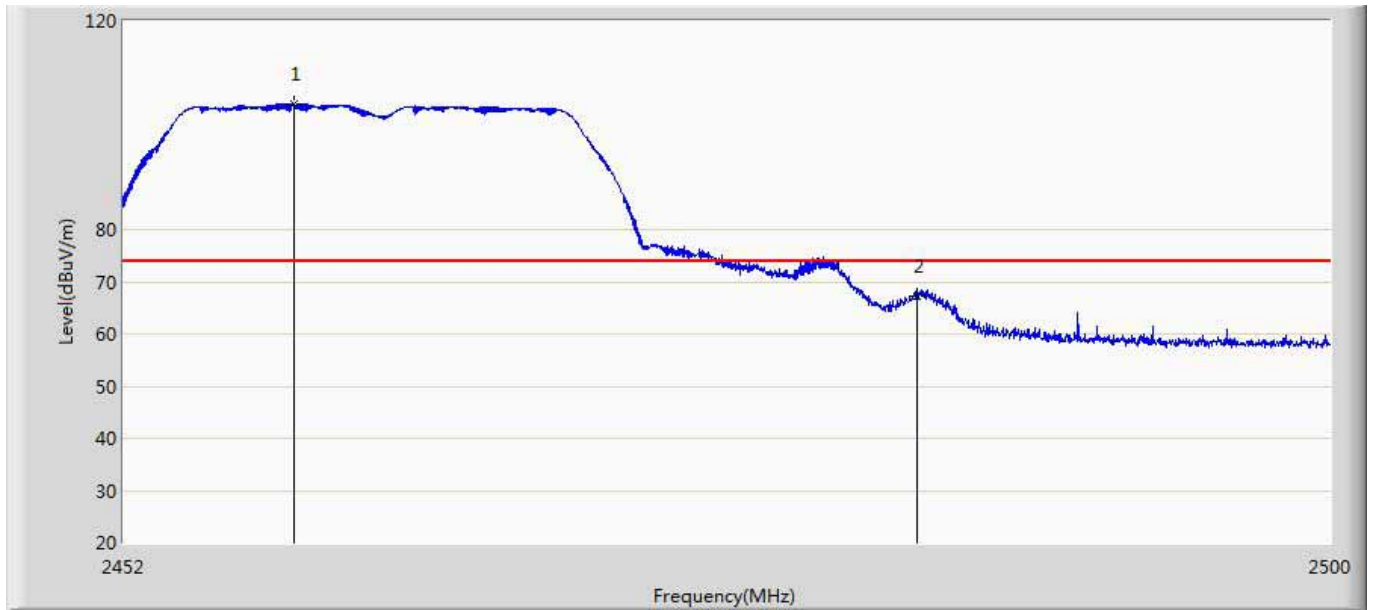

No	Mark	Frequency (MHz)	Measure Level (dBuV/m)	Reading Level (dBuV)	Over Limit (dB)	Limit (dBuV/m)	Factor (dB)	Type
1	*	2458.768	104.006	67.656	30.006	74.000	36.350	PK
2		2483.500	67.352	30.887	-6.648	74.000	36.465	PK

Site: AC5	Time: 2015/06/24 - 15:26
Limit: FCC_Part15.209_RE(3m)	Margin: 0
Probe: Horn_3117_00167055(1-18GHz)	Polarity: Vertical
EUT: Wi-Fi Module	Power: AC 120V/60Hz
Note: Mode 2 Transmit at 802.11g CH2462 by ant1	

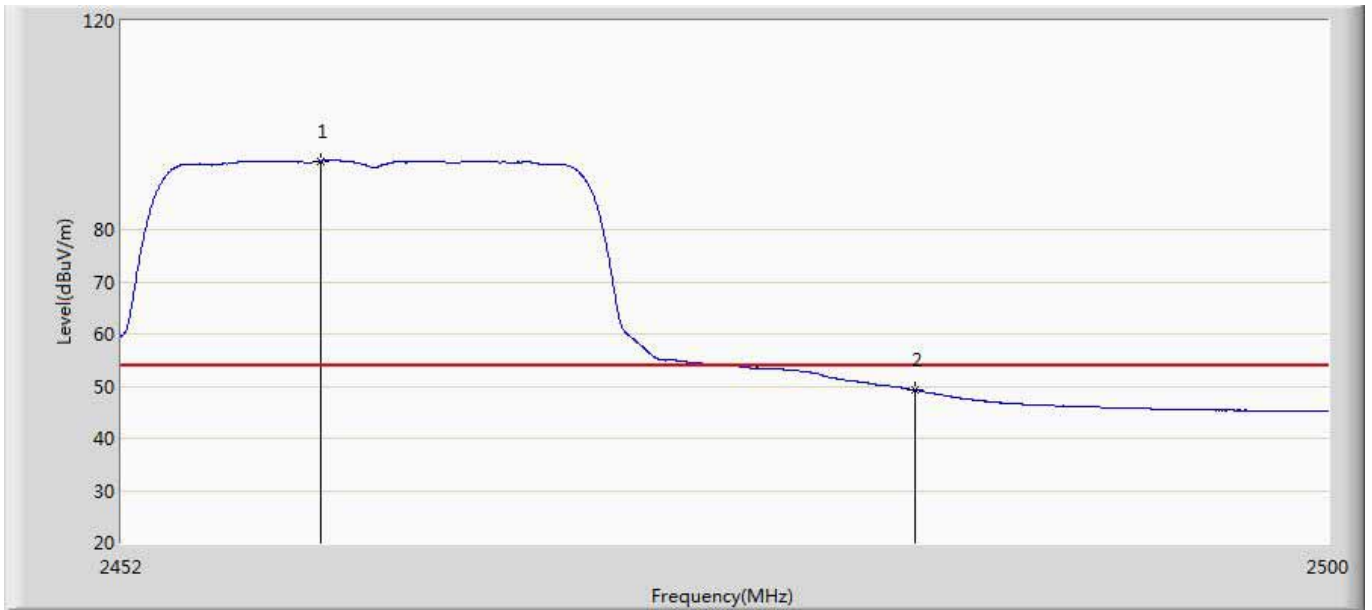

No	Mark	Frequency (MHz)	Measure Level (dBuV/m)	Reading Level (dBuV)	Over Limit (dB)	Limit (dBuV/m)	Factor (dB)	Type
1	*	2459.872	93.157	56.802	39.157	54.000	36.355	AV
2		2483.500	49.217	12.752	-4.783	54.000	36.465	AV

Site: AC5	Time: 2015/06/24 - 15:30
Limit: FCC_Part15.209_RE(3m)	Margin: 0
Probe: Horn_3117_00167055(1-18GHz)	Polarity: Horizontal
EUT: Wi-Fi Module	Power: AC 120V/60Hz
Note: Mode 2 Transmit at 802.11g CH2462 by ant1	

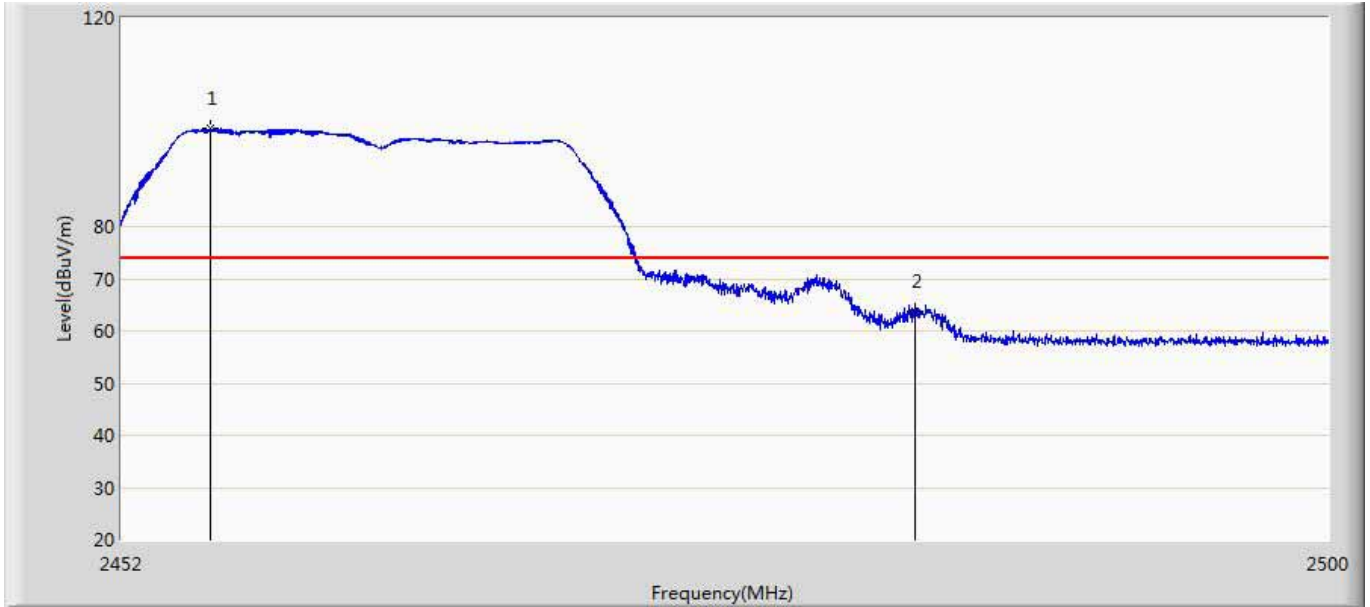

No	Mark	Frequency (MHz)	Measure Level (dBuV/m)	Reading Level (dBuV)	Over Limit (dB)	Limit (dBuV/m)	Factor (dB)	Type
1	*	2455.528	98.733	62.398	24.733	74.000	36.336	PK
2		2483.500	63.727	27.262	-10.273	74.000	36.465	PK

Site: AC5	Time: 2015/06/24 - 15:31
Limit: FCC_Part15.209_RE(3m)	Margin: 0
Probe: Horn_3117_00167055(1-18GHz)	Polarity: Horizontal
EUT: Wi-Fi Module	Power: AC 120V/60Hz
Note: Mode 2 Transmit at 802.11g CH2462 by ant1	

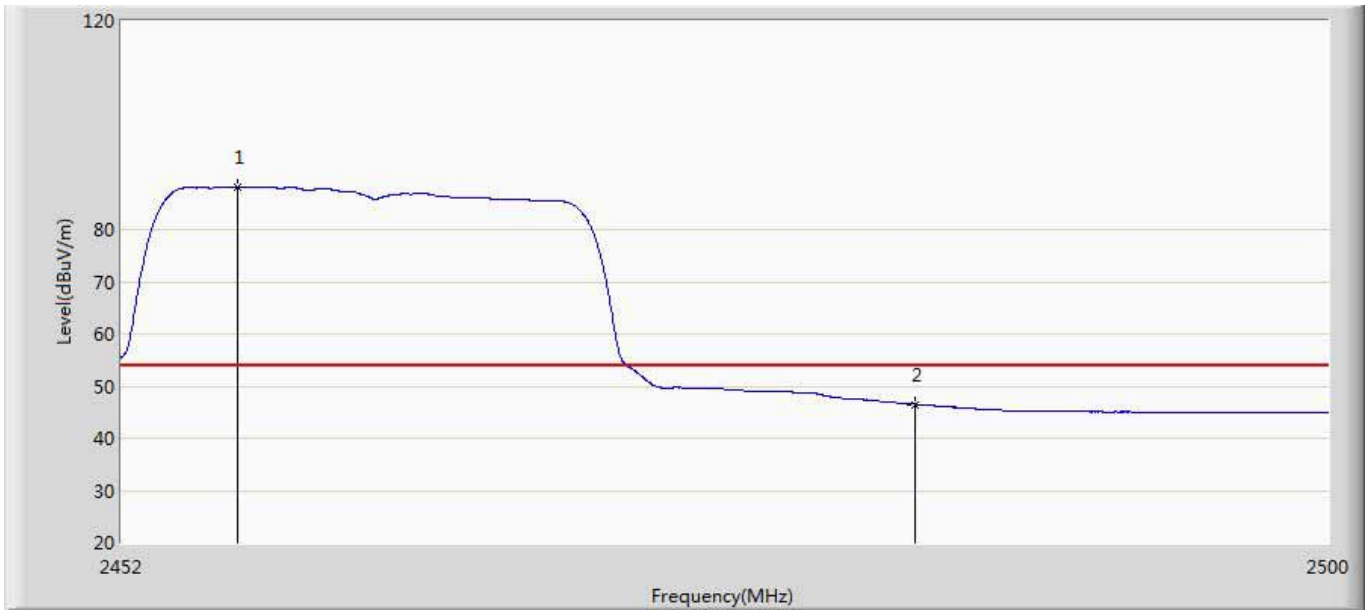

No	Mark	Frequency (MHz)	Measure Level (dBuV/m)	Reading Level (dBuV)	Over Limit (dB)	Limit (dBuV/m)	Factor (dB)	Type
1	*	2456.584	88.170	51.830	34.170	54.000	36.341	AV
2		2483.500	46.518	10.053	-7.482	54.000	36.465	AV

Site: AC5	Time: 2015/06/24 - 15:37
Limit: FCC_Part15.209_RE(3m)	Margin: 0
Probe: Horn_3117_00167055(1-18GHz)	Polarity: Vertical
EUT: Wi-Fi Module	Power: AC 120V/60Hz
Note: Mode 3 Transmit at 802.11n20 CH2412 by ant1	

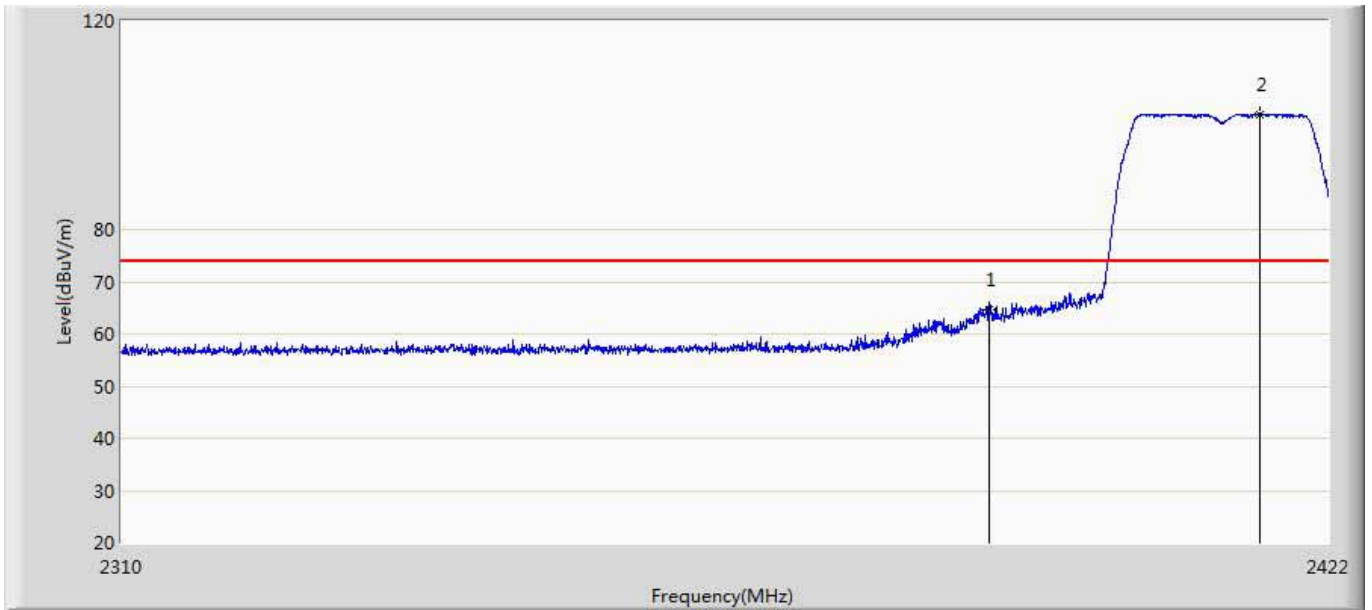

No	Mark	Frequency (MHz)	Measure Level (dBuV/m)	Reading Level (dBuV)	Over Limit (dB)	Limit (dBuV/m)	Factor (dB)	Type
1		2390.000	64.704	28.668	-9.296	74.000	36.037	PK
2	*	2415.504	102.155	66.001	28.155	74.000	36.153	PK

Site: AC5	Time: 2015/06/24 - 15:38
Limit: FCC_Part15.209_RE(3m)	Margin: 0
Probe: Horn_3117_00167055(1-18GHz)	Polarity: Vertical
EUT: Wi-Fi Module	Power: AC 120V/60Hz
Note: Mode 3 Transmit at 802.11n20 CH2412 by ant1	

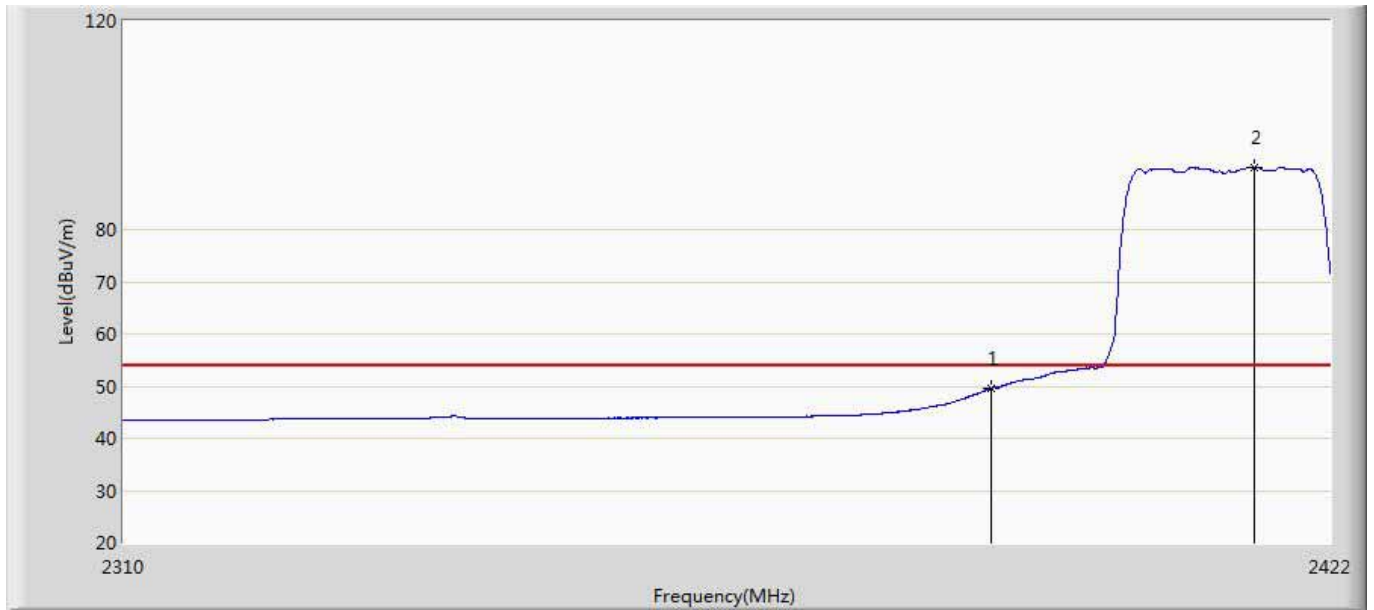

No	Mark	Frequency (MHz)	Measure Level (dBuV/m)	Reading Level (dBuV)	Over Limit (dB)	Limit (dBuV/m)	Factor (dB)	Type
1		2390.000	49.607	13.571	-4.393	54.000	36.037	AV
2	*	2414.776	92.013	55.863	38.013	54.000	36.151	AV

Site: AC5	Time: 2015/06/24 - 15:41
Limit: FCC_Part15.209_RE(3m)	Margin: 0
Probe: Horn_3117_00167055(1-18GHz)	Polarity: Horizontal
EUT: Wi-Fi Module	Power: AC 120V/60Hz
Note: Mode 3 Transmit at 802.11n20 CH2412 by ant1	

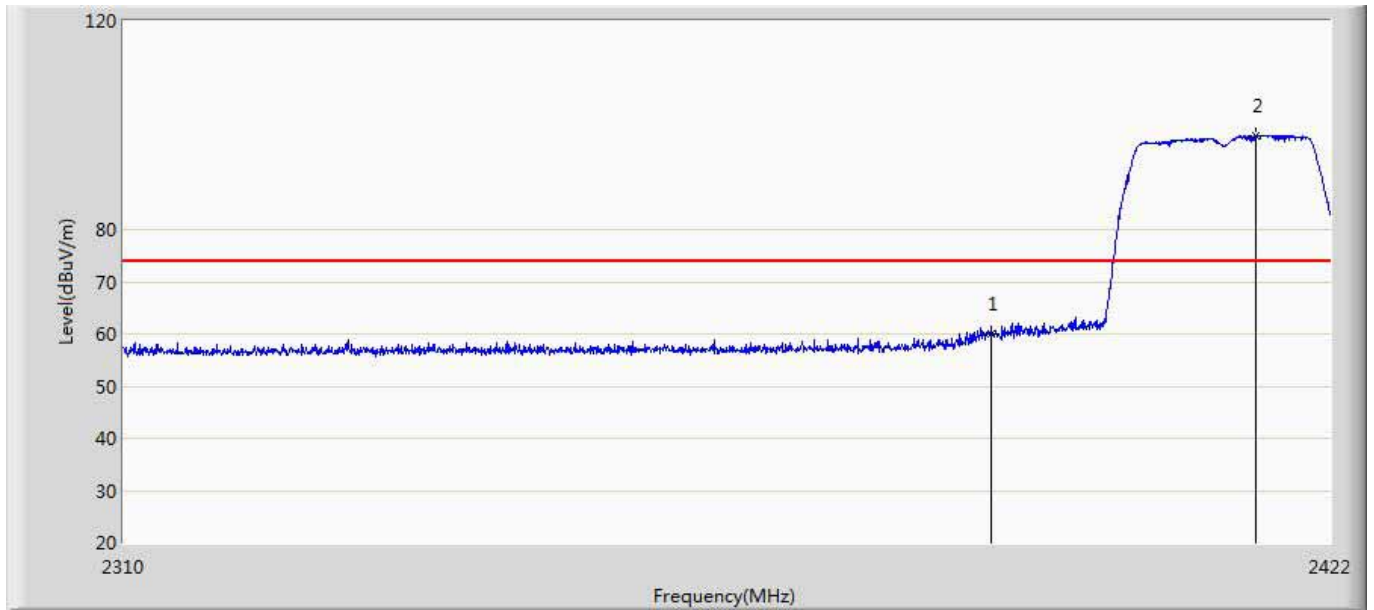

No	Mark	Frequency (MHz)	Measure Level (dBuV/m)	Reading Level (dBuV)	Over Limit (dB)	Limit (dBuV/m)	Factor (dB)	Type
1		2390.000	60.067	24.031	-13.933	74.000	36.037	PK
2	*	2415.000	97.895	61.744	23.895	74.000	36.151	PK

Site: AC5	Time: 2015/06/24 - 15:42
Limit: FCC_Part15.209_RE(3m)	Margin: 0
Probe: Horn_3117_00167055(1-18GHz)	Polarity: Horizontal
EUT: Wi-Fi Module	Power: AC 120V/60Hz
Note: Mode 3 Transmit at 802.11n20 CH2412 by ant1	

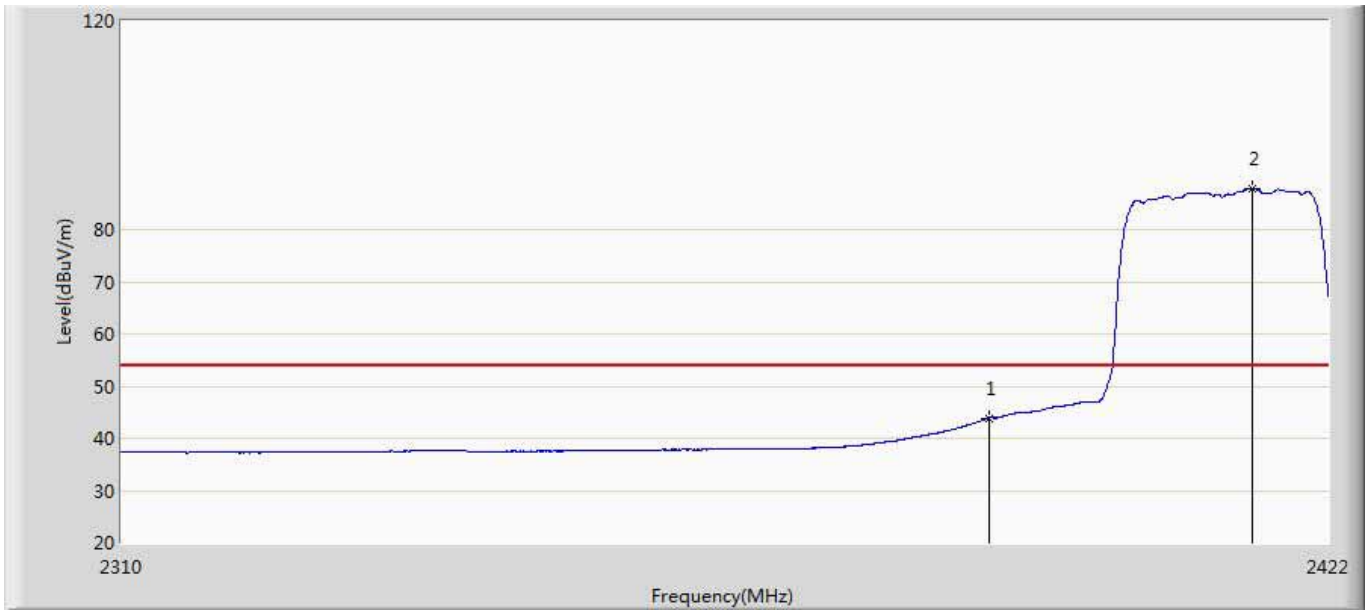

No	Mark	Frequency (MHz)	Measure Level (dBuV/m)	Reading Level (dBuV)	Over Limit (dB)	Limit (dBuV/m)	Factor (dB)	Type
1		2390.000	43.901	7.865	-10.099	54.000	36.037	AV
2	*	2414.776	87.784	51.634	33.784	54.000	36.151	AV

Site: AC5	Time: 2015/06/24 - 15:48
Limit: FCC_Part15.209_RE(3m)	Margin: 0
Probe: Horn_3117_00167055(1-18GHz)	Polarity: Vertical
EUT: Wi-Fi Module	Power: AC 120V/60Hz
Note: Mode 3 Transmit at 802.11n20 CH2462 by ant1	

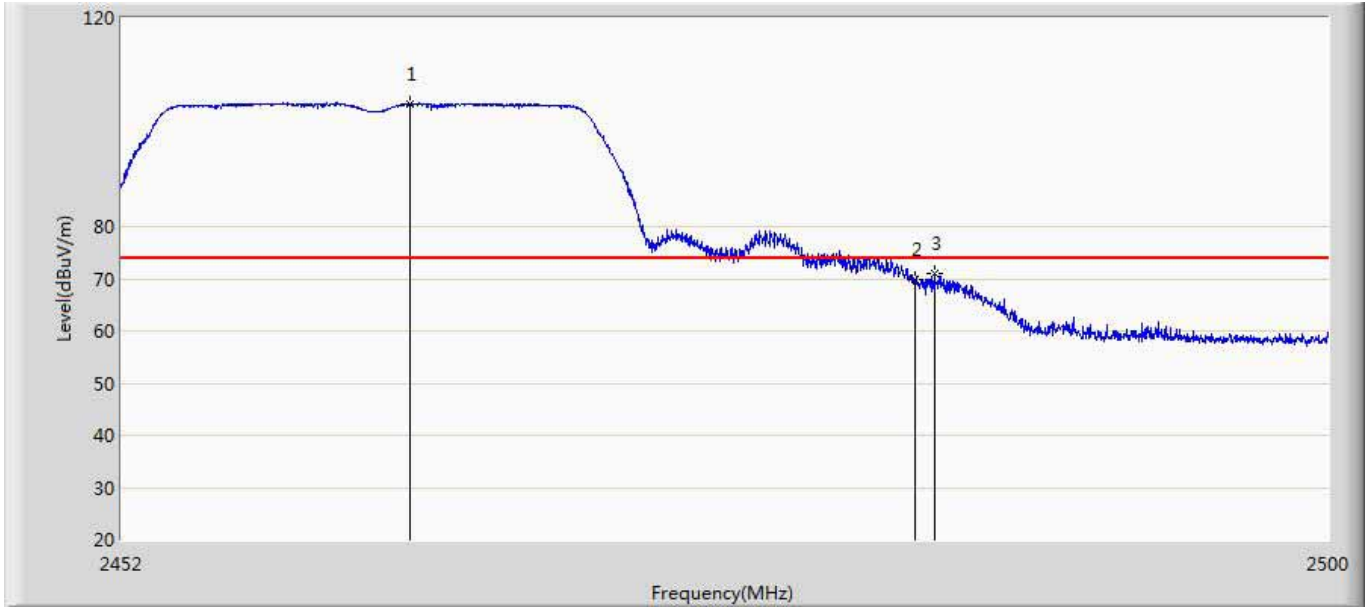

No	Mark	Frequency (MHz)	Measure Level (dBuV/m)	Reading Level (dBuV)	Over Limit (dB)	Limit (dBuV/m)	Factor (dB)	Type
1	*	2463.376	103.536	67.164	29.536	74.000	36.372	PK
2		2483.500	69.803	33.338	-4.197	74.000	36.465	PK
3		2484.232	71.143	34.674	-2.857	74.000	36.469	PK

Site: AC5	Time: 2015/06/24 - 15:48
Limit: FCC_Part15.209_RE(3m)	Margin: 0
Probe: Horn_3117_00167055(1-18GHz)	Polarity: Vertical
EUT: Wi-Fi Module	Power: AC 120V/60Hz
Note: Mode 3 Transmit at 802.11n20 CH2462 by ant1	

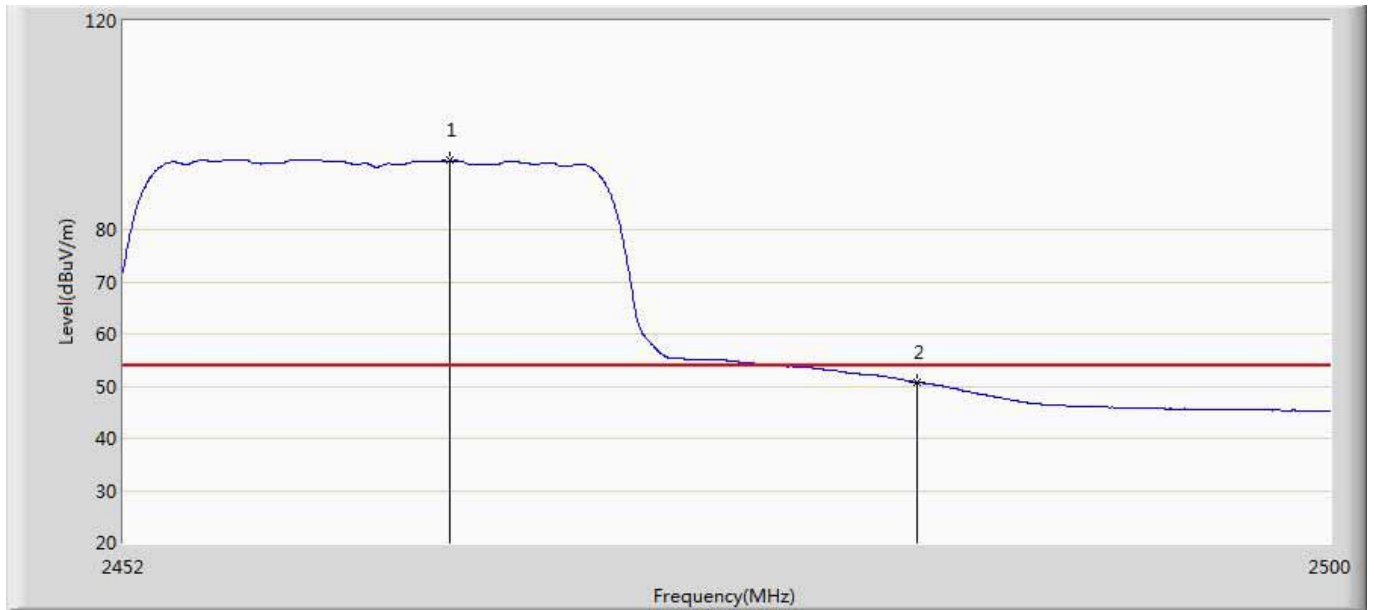

No	Mark	Frequency (MHz)	Measure Level (dBuV/m)	Reading Level (dBuV)	Over Limit (dB)	Limit (dBuV/m)	Factor (dB)	Type
1	*	2464.888	93.195	56.816	39.195	54.000	36.378	AV
2		2483.500	50.707	14.242	-3.293	54.000	36.465	AV

Site: AC5	Time: 2015/06/24 - 15:53
Limit: FCC_Part15.209_RE(3m)	Margin: 0
Probe: Horn_3117_00167055(1-18GHz)	Polarity: Horizontal
EUT: Wi-Fi Module	Power: AC 120V/60Hz
Note: Mode 3 Transmit at 802.11n20 CH2462 by ant1	

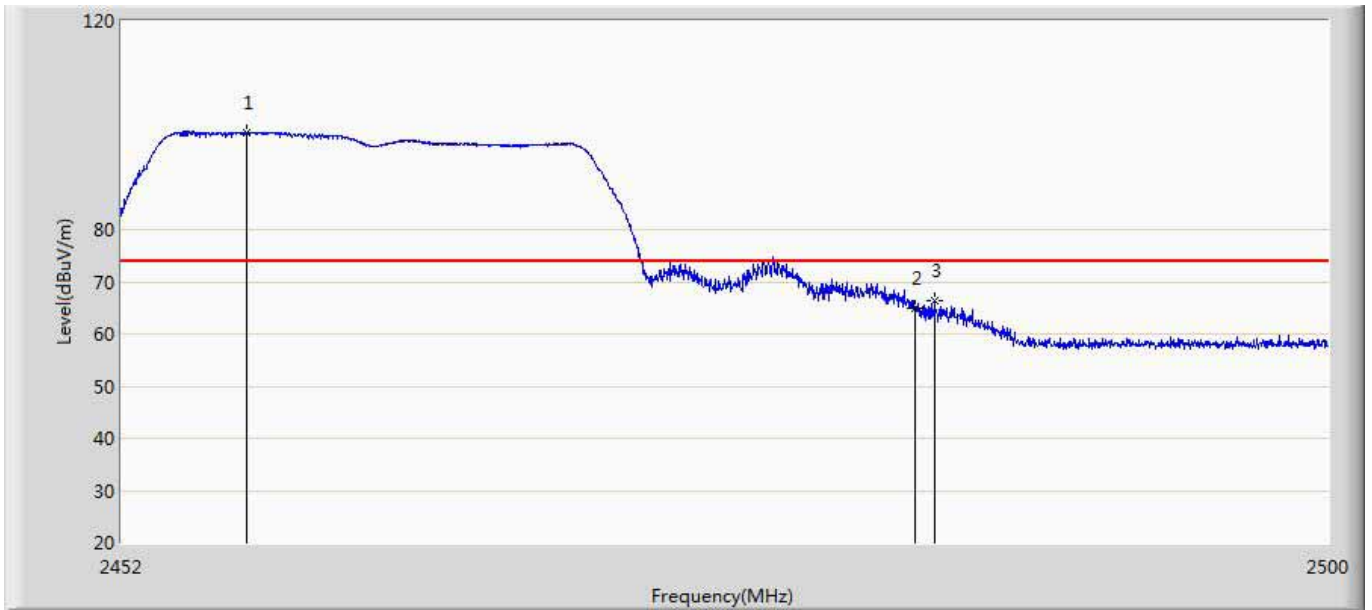

No	Mark	Frequency (MHz)	Measure Level (dBuV/m)	Reading Level (dBuV)	Over Limit (dB)	Limit (dBuV/m)	Factor (dB)	Type
1	*	2456.920	98.517	62.175	24.517	74.000	36.342	PK
2		2483.500	64.994	28.529	-9.006	74.000	36.465	PK
3		2484.256	66.304	29.835	-7.696	74.000	36.469	PK

Site: AC5	Time: 2015/06/24 - 15:53
Limit: FCC_Part15.209_RE(3m)	Margin: 0
Probe: Horn_3117_00167055(1-18GHz)	Polarity: Horizontal
EUT: Wi-Fi Module	Power: AC 120V/60Hz
Note: Mode 3 Transmit at 802.11n20 CH2462 by ant1	

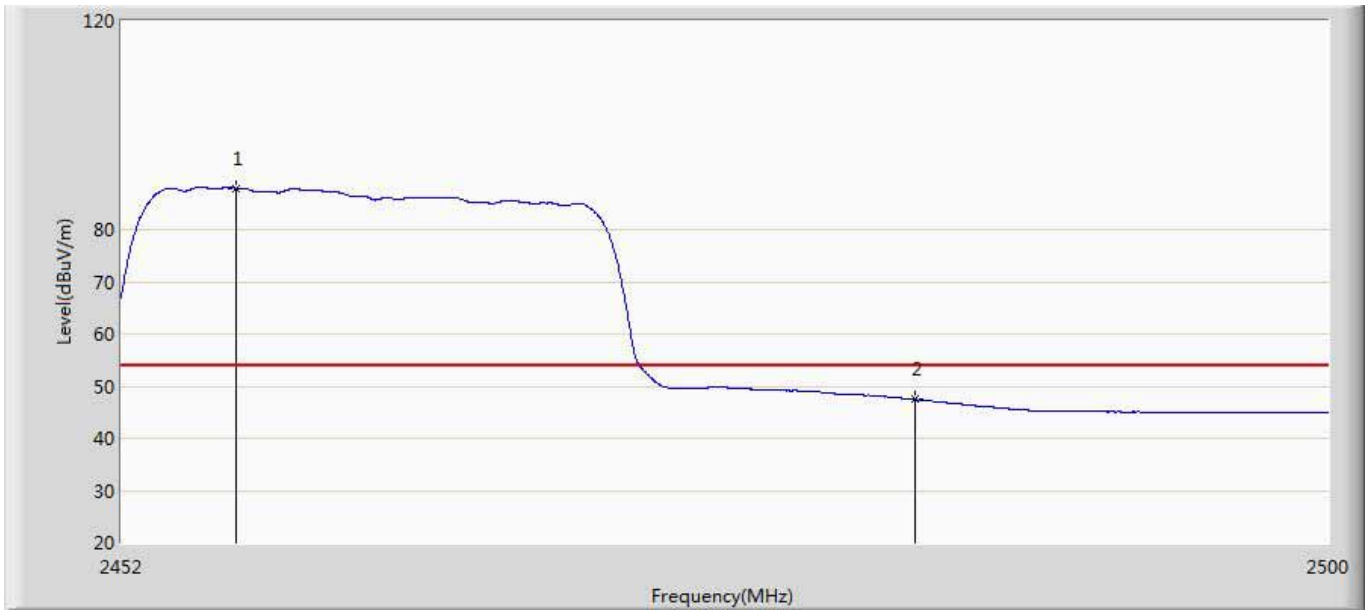

No	Mark	Frequency (MHz)	Measure Level (dBuV/m)	Reading Level (dBuV)	Over Limit (dB)	Limit (dBuV/m)	Factor (dB)	Type
1	*	2456.512	87.952	51.612	33.952	54.000	36.340	AV
2		2483.500	47.411	10.946	-6.589	54.000	36.465	AV

Site: AC5	Time: 2015/06/24 - 16:10
Limit: FCC_Part15.209_RE(3m)	Margin: 0
Probe: Horn_3117_00167055(1-18GHz)	Polarity: Vertical
EUT: Wi-Fi Module	Power: AC 120V/60Hz
Note: Mode 4 Transmit at 802.11n40 CH2422 by ant1	

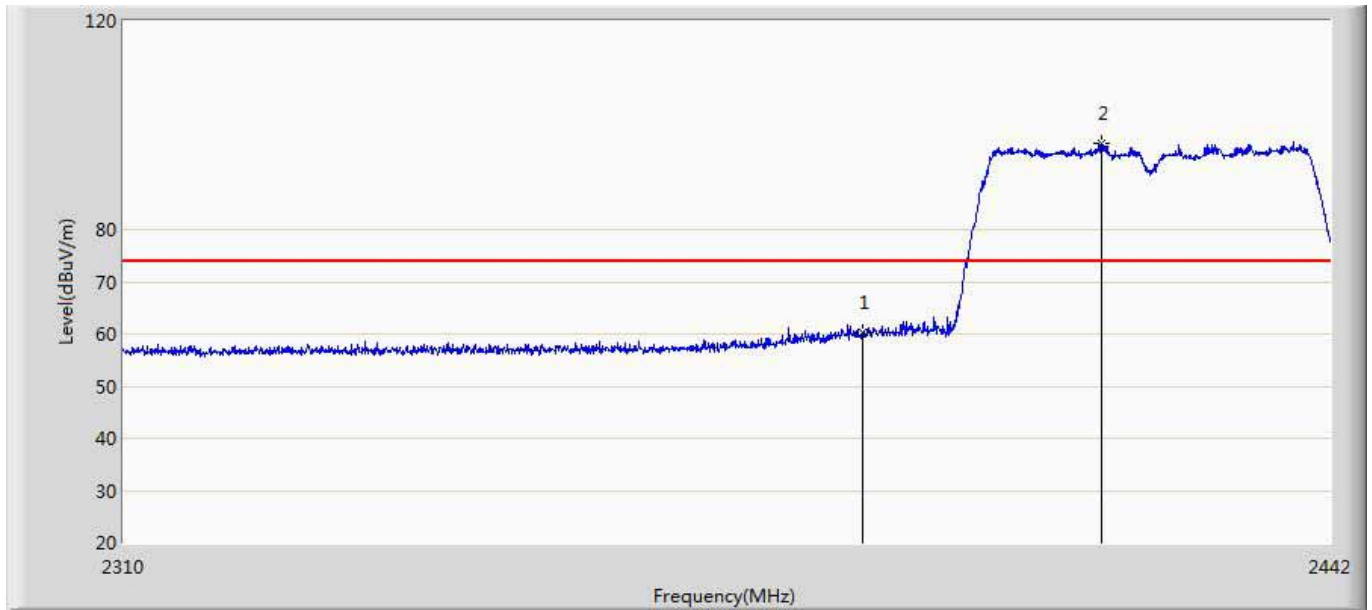

No	Mark	Frequency (MHz)	Measure Level (dBuV/m)	Reading Level (dBuV)	Over Limit (dB)	Limit (dBuV/m)	Factor (dB)	Type
1		2390.000	60.245	24.209	-13.755	74.000	36.037	PK
2	*	2416.458	96.476	60.318	22.476	74.000	36.158	PK

Site: AC5	Time: 2015/06/24 - 16:10
Limit: FCC_Part15.209_RE(3m)	Margin: 0
Probe: Horn_3117_00167055(1-18GHz)	Polarity: Vertical
EUT: Wi-Fi Module	Power: AC 120V/60Hz
Note: Mode 4 Transmit at 802.11n40 CH2422 by ant1	

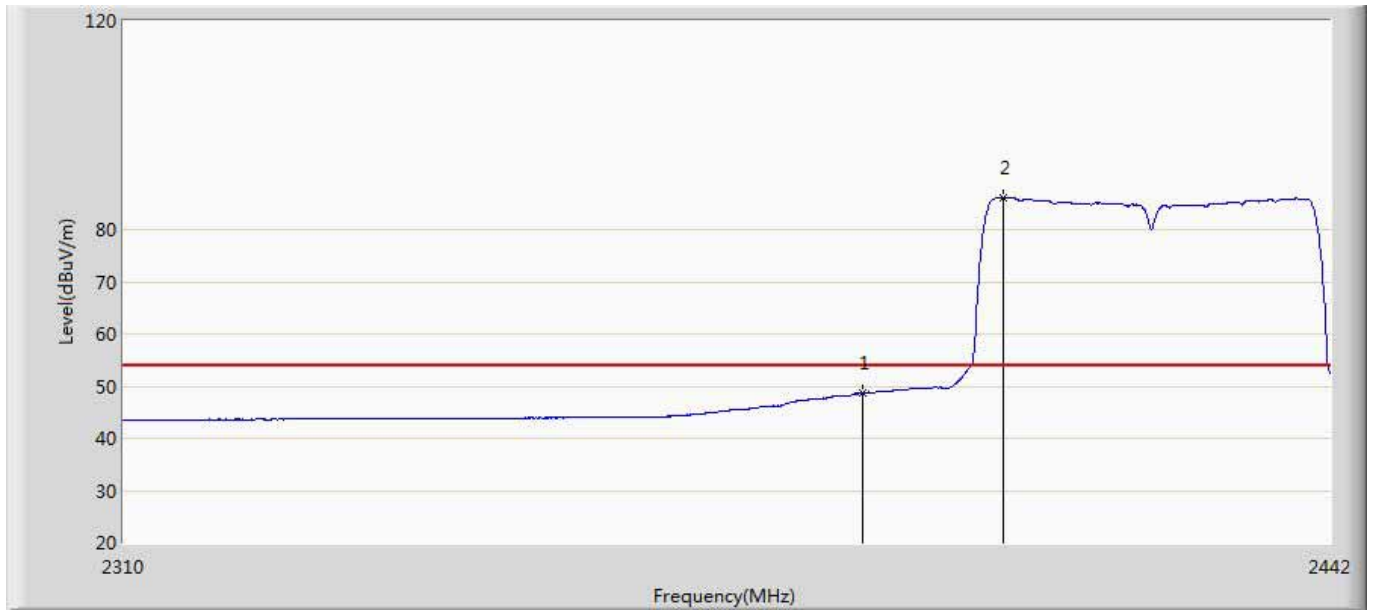

No	Mark	Frequency (MHz)	Measure Level (dBuV/m)	Reading Level (dBuV)	Over Limit (dB)	Limit (dBuV/m)	Factor (dB)	Type
1		2390.000	48.712	12.676	-5.288	54.000	36.037	AV
2	*	2405.568	86.000	49.892	32.000	54.000	36.108	AV

Site: AC5	Time: 2015/06/24 - 16:16
Limit: FCC_Part15.209_RE(3m)	Margin: 0
Probe: Horn_3117_00167055(1-18GHz)	Polarity: Horizontal
EUT: Wi-Fi Module	Power: AC 120V/60Hz
Note: Mode 4 Transmit at 802.11n40 CH2422 by ant1	

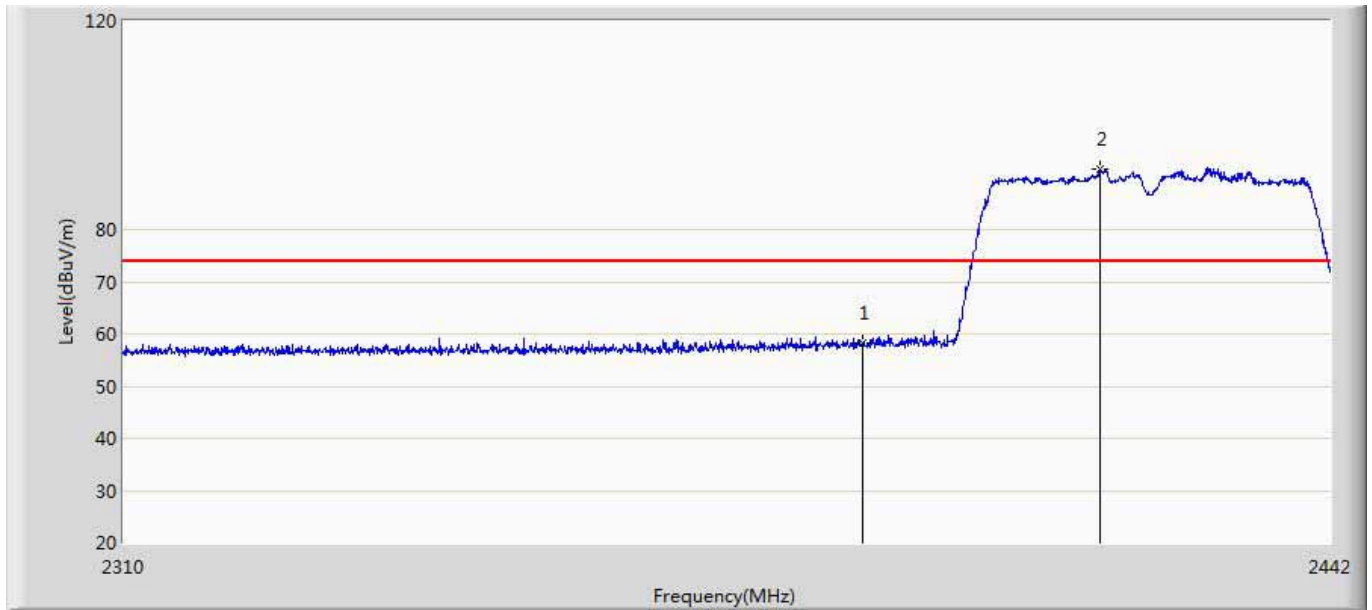

No	Mark	Frequency (MHz)	Measure Level (dBuV/m)	Reading Level (dBuV)	Over Limit (dB)	Limit (dBuV/m)	Factor (dB)	Type
1		2390.000	58.163	22.127	-15.837	74.000	36.037	PK
2	*	2416.326	91.651	55.494	17.651	74.000	36.157	PK

Site: AC5	Time: 2015/06/24 - 16:17
Limit: FCC_Part15.209_RE(3m)	Margin: 0
Probe: Horn_3117_00167055(1-18GHz)	Polarity: Horizontal
EUT: Wi-Fi Module	Power: AC 120V/60Hz
Note: Mode 4 Transmit at 802.11n40 CH2422 by ant1	

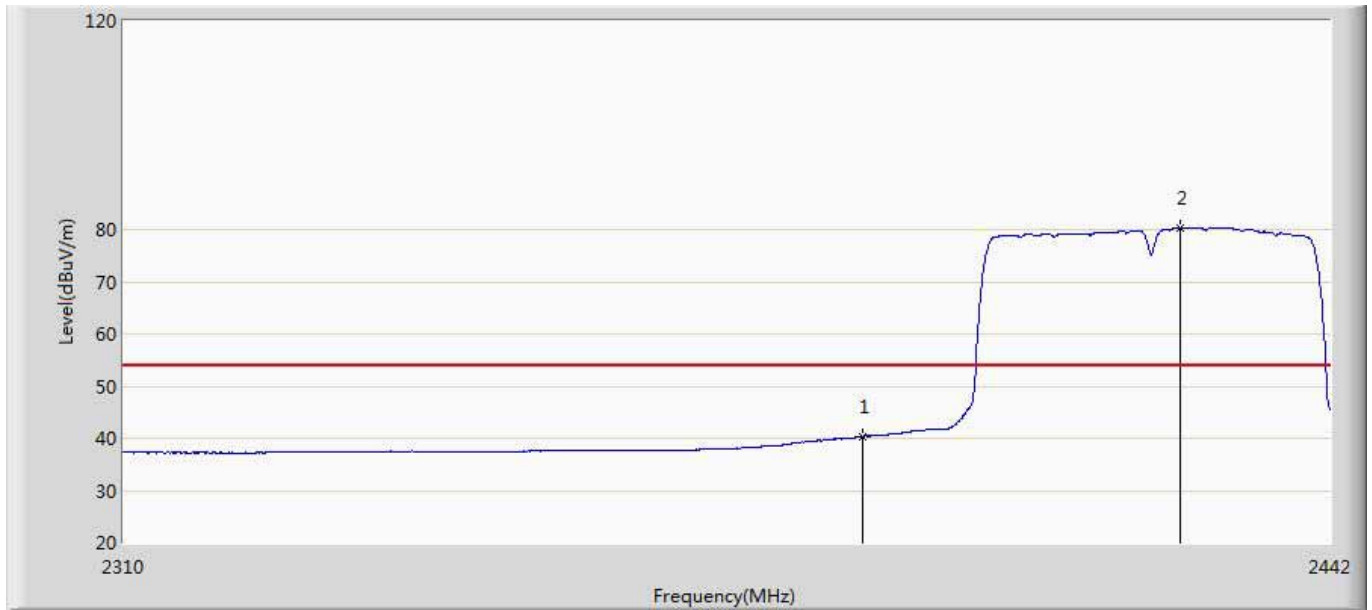

No	Mark	Frequency (MHz)	Measure Level (dBuV/m)	Reading Level (dBuV)	Over Limit (dB)	Limit (dBuV/m)	Factor (dB)	Type
1		2390.000	40.409	4.373	-13.591	54.000	36.037	AV
2	*	2425.236	80.329	44.132	26.329	54.000	36.197	AV

Site: AC5	Time: 2015/06/24 - 16:22
Limit: FCC_Part15.209_RE(3m)	Margin: 0
Probe: Horn_3117_00167055(1-18GHz)	Polarity: Vertical
EUT: Wi-Fi Module	Power: AC 120V/60Hz
Note: Mode 4 Transmit at 802.11n40 CH2452 by ant1	

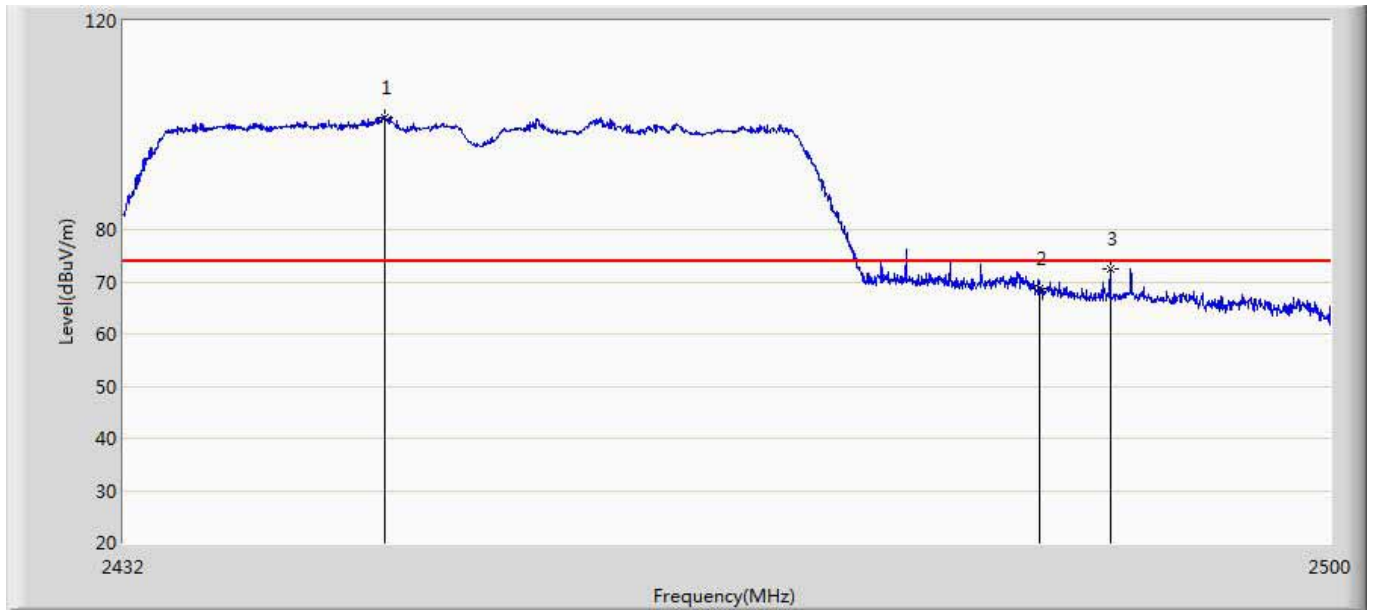

No	Mark	Frequency (MHz)	Measure Level (dBuV/m)	Reading Level (dBuV)	Over Limit (dB)	Limit (dBuV/m)	Factor (dB)	Type
1	*	2446.620	101.539	65.245	27.539	74.000	36.294	PK
2		2483.500	68.758	32.293	-5.242	74.000	36.465	PK
3		2487.488	72.380	35.896	-1.620	74.000	36.484	PK

Site: AC5	Time: 2015/06/24 - 16:22
Limit: FCC_Part15.209_RE(3m)	Margin: 0
Probe: Horn_3117_00167055(1-18GHz)	Polarity: Vertical
EUT: Wi-Fi Module	Power: AC 120V/60Hz
Note: Mode 4 Transmit at 802.11n40 CH2452 by ant1	

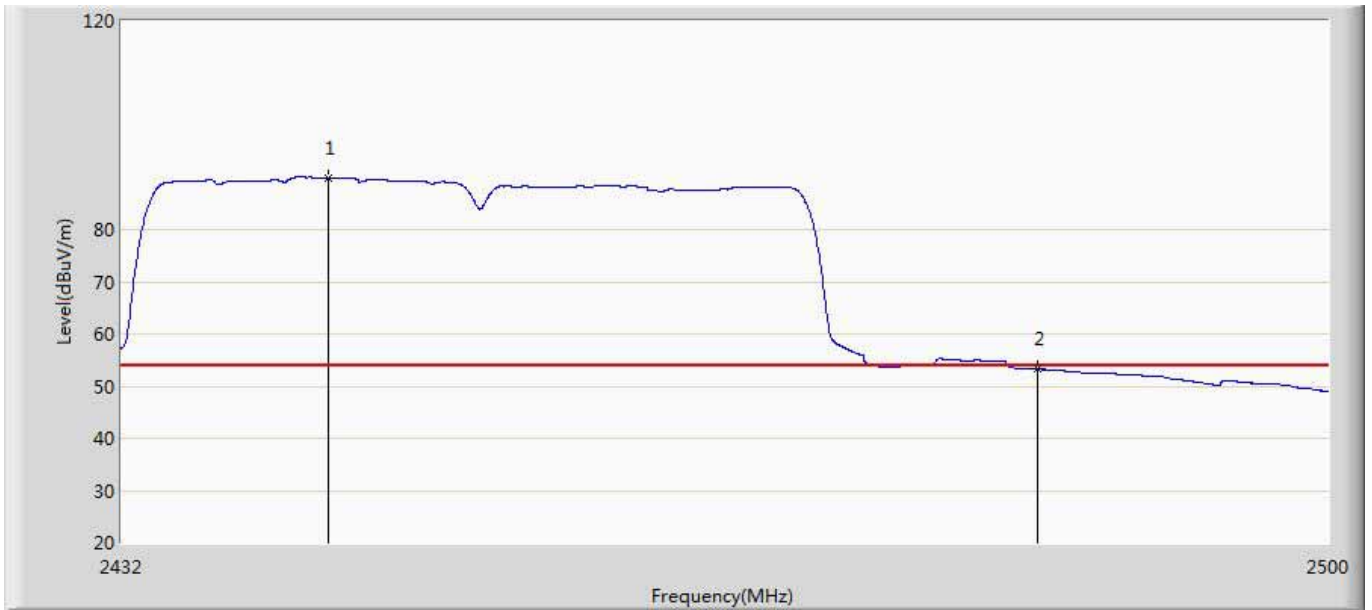

No	Mark	Frequency (MHz)	Measure Level (dBuV/m)	Reading Level (dBuV)	Over Limit (dB)	Limit (dBuV/m)	Factor (dB)	Type
1	*	2443.526	89.837	53.557	35.837	54.000	36.280	AV
2		2483.500	53.249	16.784	-0.751	54.000	36.465	AV

Site: AC5	Time: 2015/06/24 - 16:26
Limit: FCC_Part15.209_RE(3m)	Margin: 0
Probe: Horn_3117_00167055(1-18GHz)	Polarity: Horizontal
EUT: Wi-Fi Module	Power: AC 120V/60Hz
Note: Mode 4 Transmit at 802.11n40 CH2452 by ant1	

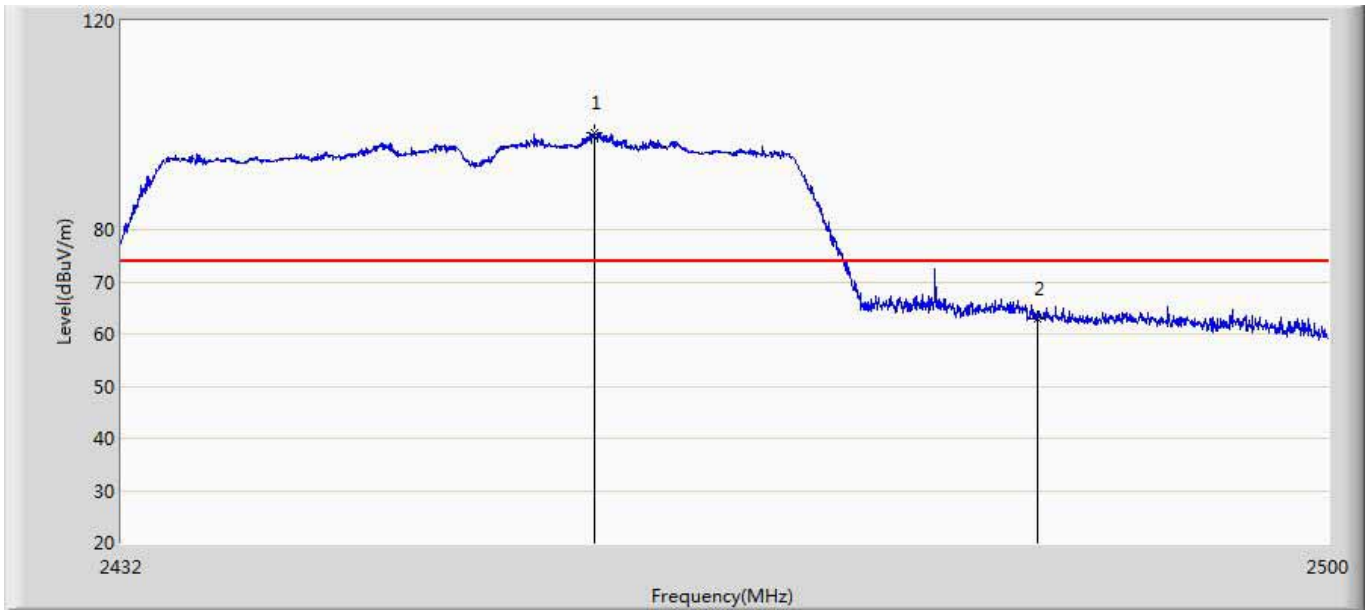

No	Mark	Frequency (MHz)	Measure Level (dBuV/m)	Reading Level (dBuV)	Over Limit (dB)	Limit (dBuV/m)	Factor (dB)	Type
1	*	2458.418	98.566	62.217	24.566	74.000	36.348	PK
2		2483.500	62.976	26.511	-11.024	74.000	36.465	PK

Site: AC5	Time: 2015/06/24 - 16:27
Limit: FCC_Part15.209_RE(3m)	Margin: 0
Probe: Horn_3117_00167055(1-18GHz)	Polarity: Horizontal
EUT: Wi-Fi Module	Power: AC 120V/60Hz
Note: Mode 4 Transmit at 802.11n40 CH2452 by ant1	

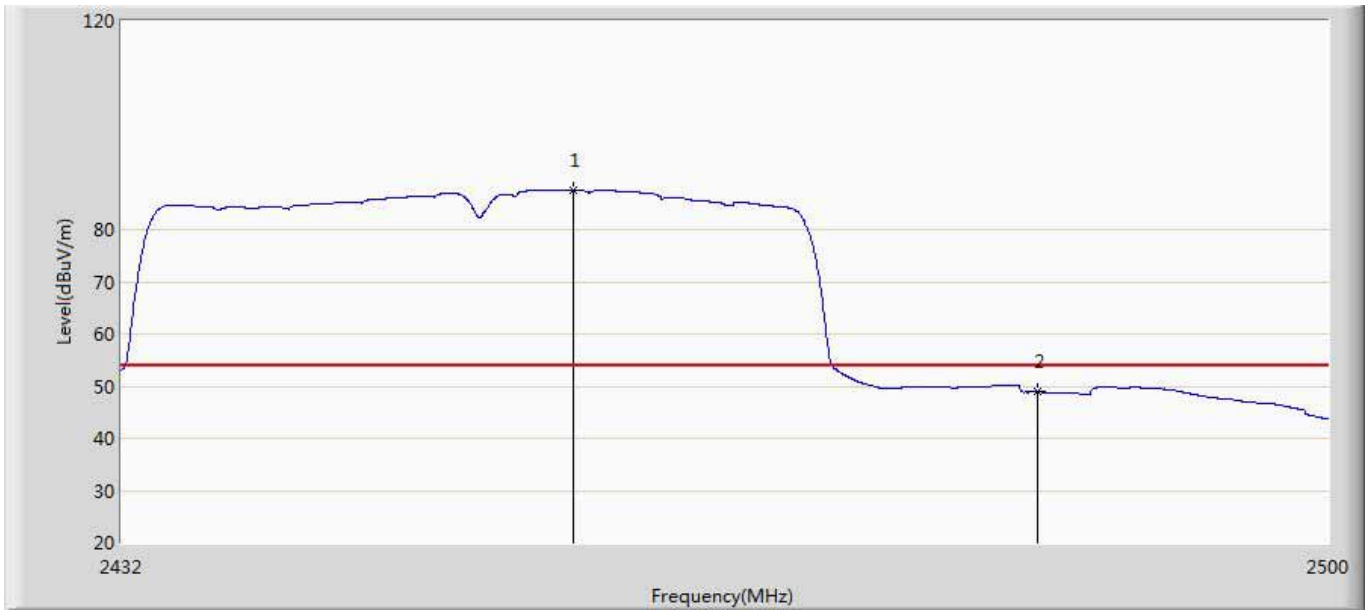

No	Mark	Frequency (MHz)	Measure Level (dBuV/m)	Reading Level (dBuV)	Over Limit (dB)	Limit (dBuV/m)	Factor (dB)	Type
1	*	2457.296	87.610	51.267	33.610	54.000	36.343	AV
2		2483.500	48.892	12.427	-5.108	54.000	36.465	AV

8. Occupied Bandwidth

8.1. Test Equipment

Occupied Bandwidth / TR-8

Instrument	Manufacturer	Type No.	Serial No.	Cal. Due Date
Spectrum Analyzer	Agilent	N9010A	MY48030494	2016.03.10
Temperature/Humidity Meter	zhicheng	ZC1-2	TR8-TH	2016.04.09

Note: All equipments are calibrated with traceable calibrations. Each calibration is traceable to the national or international standards.

8.2. Test Setup

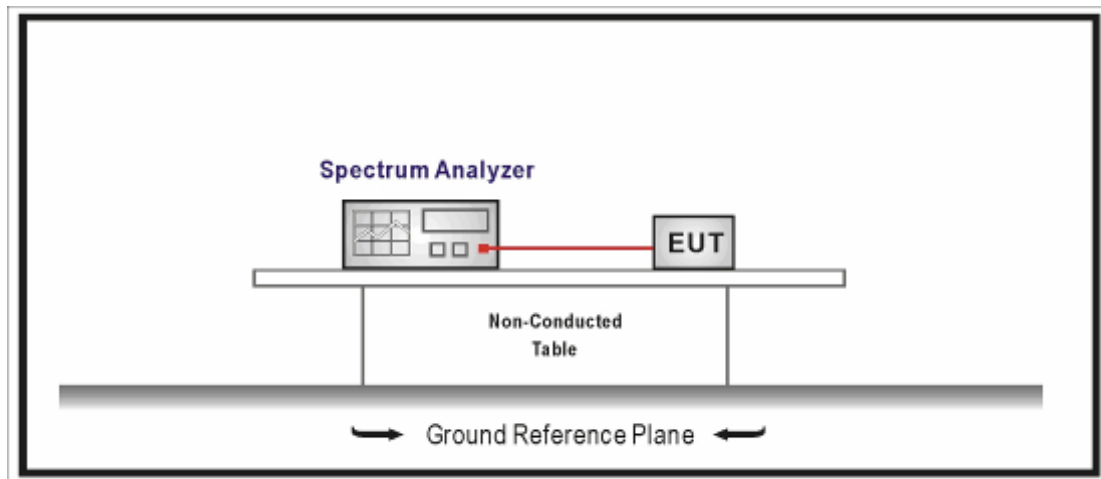

8.3. Limit

For IC

99% occupied bandwidth should be less than the nominal bandwidth.

For FCC

The minimum 6dB bandwidth shall be at least 500 kHz.

8.4. Test Procedure

According to FCC ANSI C63.4: 2014 & ANSI C63.10: 2013& FCC 47CFR 15.247& KDB 558074 D01v03r03& Industry Canada RSS-Gen Issue 4& RSS-247 Issue 1

- a) Set RBW = in the range of 1% to 5% of the OBW.
- b) Set the video bandwidth (VBW) $\geq 3 \times$ RBW.

- c) Detector = Peak.
- d) Trace mode = max hold.
- e) Sweep = auto couple.
- f) Allow the trace to stabilize.
- g) Use the 99% power bandwidth and -6dBm function of the instrument (if available) and report the measured bandwidth.

8.5. Uncertainty

The measurement uncertainty is defined as ± 1 kHz

8.6. Test Result

Product	:	Wi-Fi Module
Test Item	:	6dB Occupied Bandwidth
Test Mode	:	Mode 1: Transmit by 802.11b

Ant 0

Channel No.	Frequency (MHz)	99%Occupied Bandwidth (kHz)	6dB Occupied Bandwidth (kHz)	Limit (kHz)	Result
01	2412	15068	10040	500	Pass
06	2437	15658	10040	500	Pass
11	2462	15248	10060	500	Pass

Channel 01 (2412MHz)



Channel 06 (2437MHz)



Channel 11 (2462MHz)



Ant 1

Channel No.	Frequency (MHz)	99%Occupied Bandwidth (kHz)	6dB Occupied Bandwidth (kHz)	Limit (kHz)	Result
01	2412	14730	10050	500	Pass
06	2437	14988	10050	500	Pass
11	2462	14360	10040	500	Pass

Channel 01 (2412MHz)



Channel 06 (2437MHz)



Channel 11 (2462MHz)



Product	:	Wi-Fi Module
Test Item	:	6dB Occupied Bandwidth
Test Mode	:	Mode 2: Transmit by 802.11g

Ant 0

Channel No.	Frequency (MHz)	99%Occupied Bandwidth (kHz)	6dB Occupied Bandwidth (kHz)	Limit (kHz)	Result
01	2412	16495	16490	500	Pass
06	2437	17565	16560	500	Pass
11	2462	16495	16440	500	Pass

Channel 01 (2412MHz)



Channel 06 (2437MHz)



Channel 11 (2462MHz)



Ant 1

Channel No.	Frequency (MHz)	99%Occupied Bandwidth (kHz)	6dB Occupied Bandwidth (kHz)	Limit (kHz)	Result
01	2412	16477	16620	500	Pass
06	2437	16867	16620	500	Pass
11	2462	16477	16590	500	Pass

Channel 01 (2412MHz)



Channel 06 (2437MHz)

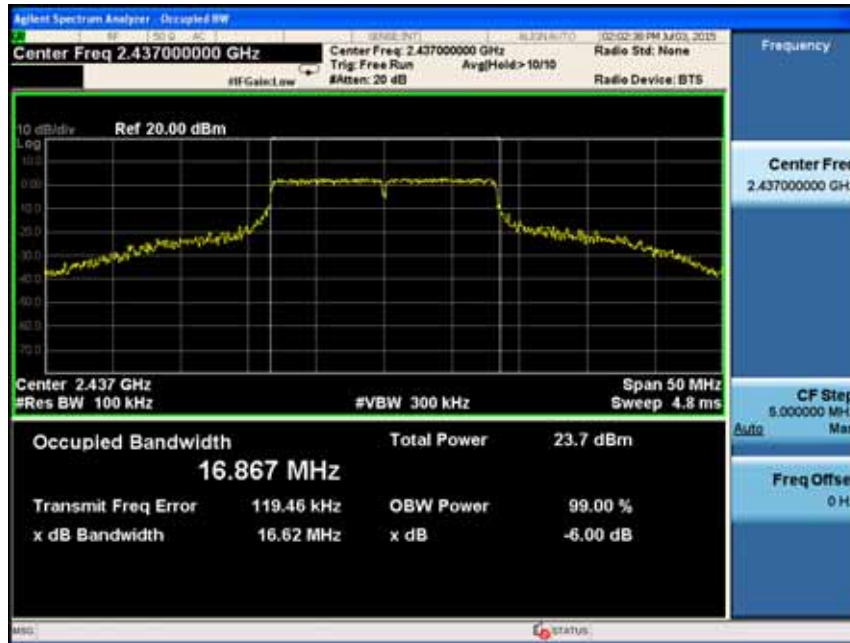

Channel 11 (2462MHz)



Product	:	Wi-Fi Module
Test Item	:	6dB Occupied Bandwidth
Test Mode	:	Mode 3: Transmit by 802.11 n(20MHz)

Ant 0

Channel No.	Frequency (MHz)	99%Occupied Bandwidth (kHz)	6dB Occupied Bandwidth (kHz)	Limit (kHz)	Result
01	2412	17727	17850	500	Pass
06	2437	17793	17850	500	Pass
11	2462	17736	17860	500	Pass

Channel 01 (2412MHz)

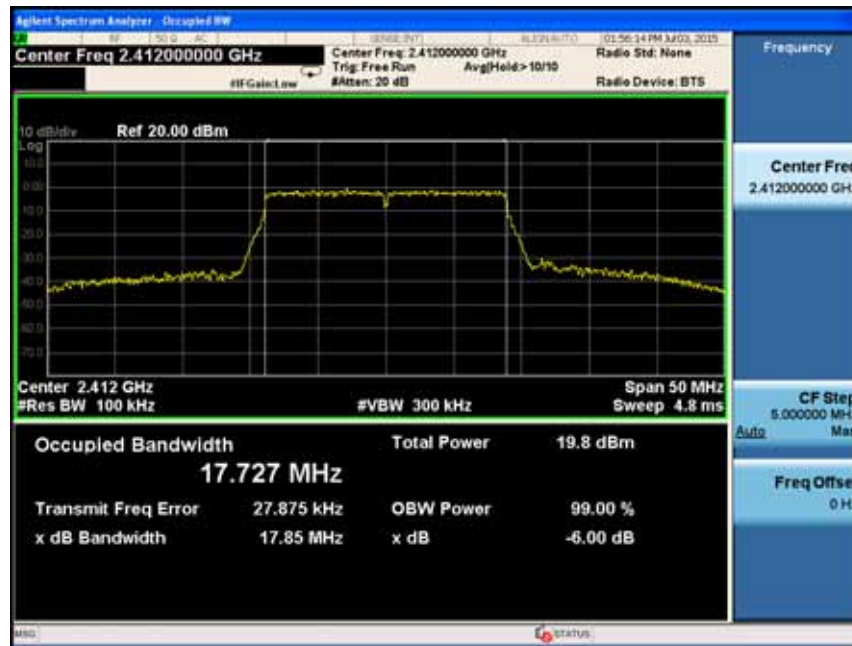

Channel 06 (2437MHz)

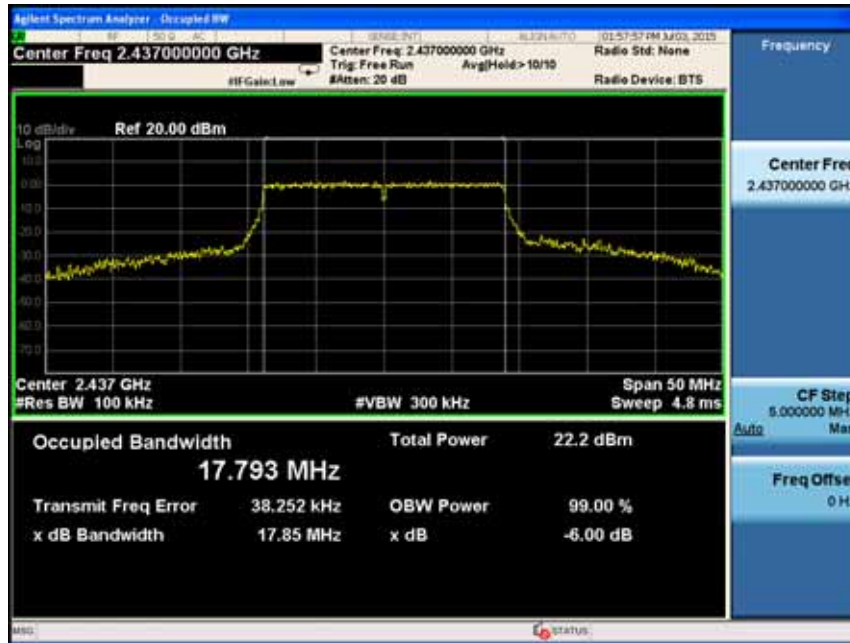

Channel 11 (2462MHz)



Ant 1

Channel No.	Frequency (MHz)	99%Occupied Bandwidth (kHz)	6dB Occupied Bandwidth (kHz)	Limit (kHz)	Result
01	2412	17727	17860	500	Pass
06	2437	17786	17830	500	Pass
11	2462	17710	17840	500	Pass

Channel 01 (2412MHz)



Channel 06 (2437MHz)

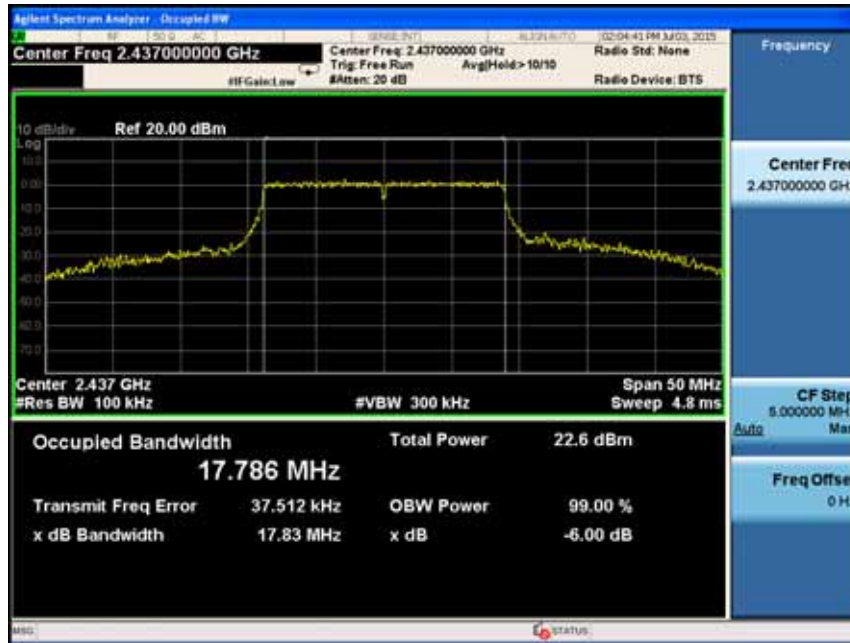

Channel 11 (2462MHz)



Product	:	Wi-Fi Module
Test Item	:	6dB Occupied Bandwidth
Test Mode	:	Mode 4: Transmit by 802.11 n(40MHz)

Ant 0

Channel No.	Frequency (MHz)	99%Occupied Bandwidth (kHz)	6dB Occupied Bandwidth (kHz)	Limit (kHz)	Result
03	2422	36329	36650	500	Pass
06	2437	36284	36630	500	Pass
09	2452	36803	37030	500	Pass

Channel 03 (2422MHz)

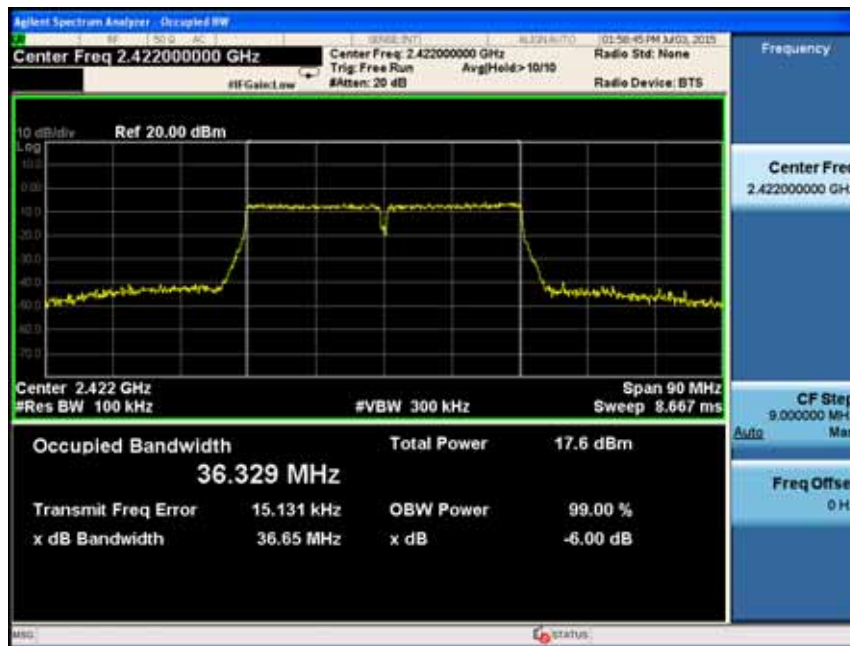

Channel 06 (2437MHz)

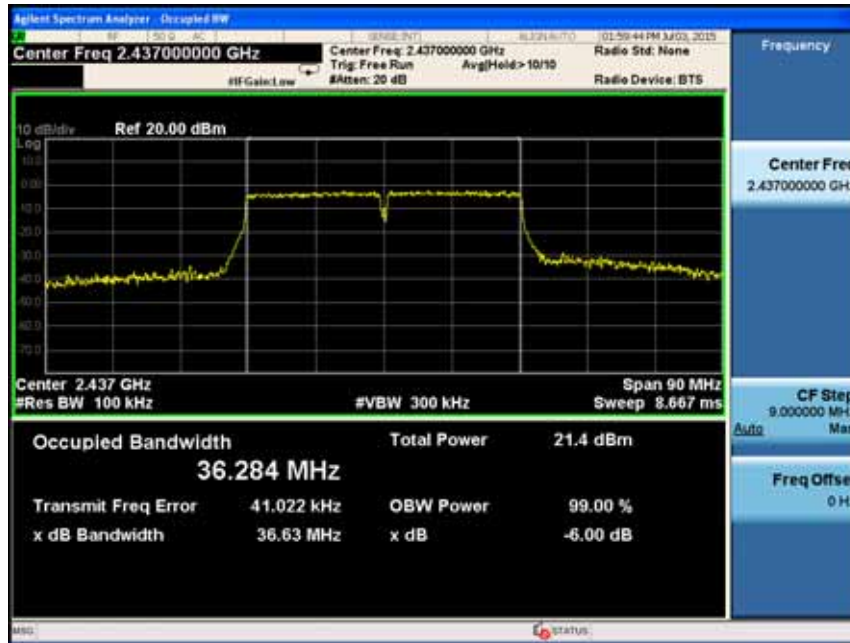

Channel 09 (2452MHz)



Ant 1

Channel No.	Frequency (MHz)	99%Occupied Bandwidth (kHz)	6dB Occupied Bandwidth (kHz)	Limit (kHz)	Result
03	2422	36295	36630	500	Pass
06	2437	36285	36620	500	Pass
09	2452	36269	36630	500	Pass

Channel 03 (2422MHz)



Channel 06 (2437MHz)



Channel 09 (2452MHz)



9. Power Output

9.1. Test Equipment

Power Output / TR-8

Instrument	Manufacturer	Type No.	Serial No.	Cal. Due Date
Wideband Peak Power Meter	Anritsu	ML2495A	0905006	2015.11.10
Power Sensor	Anritsu	MA2411B	0846014	2015.11.10
Temperature/Humidity Meter	zhicheng	ZC1-2	TR8-TH	2016.04.09

Note: All equipments are calibrated with traceable calibrations. Each calibration is traceable to the national or international standards.

9.2. Test Setup

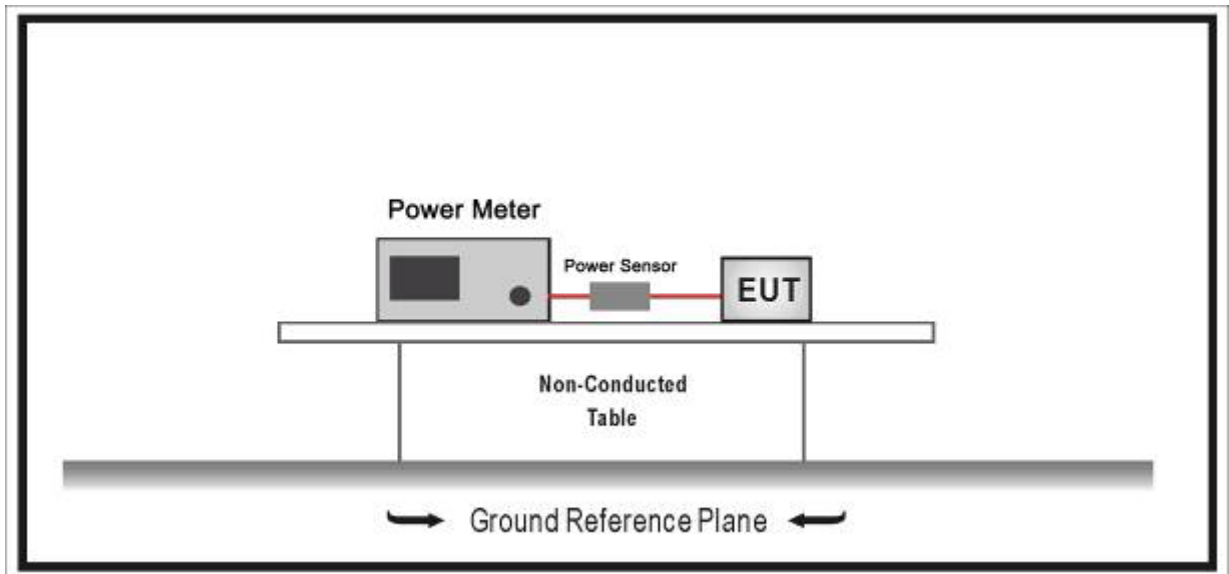

9.3. Limit

For FCC&IC

The maximum peak power shall be less 1 Watt (30dBm).

Note: the conducted output power limit specified above is based on the use the antennas with directional gains that do not exceed 6 dBi are used, the conducted output power from the intentional radiator shall be reduced below the stated values above, as appropriate, by the amount in dB that the directional gain of antenna exceeds 6 dBi.

9.4. Test Procedure

According to FCC ANSI C63.4: 2014 & ANSI C63.10: 2013& FCC 47CFR 15.247& KDB 558074 D01v03r03& Industry Canada RSS-Gen Issue 4& RSS-247 Issue 1

1. Power meter and sensor's minimum video bandwidth is 50MHz, larger than 802.11n(40MHz) bandwidth;
2. Fast responding diode sensors respond immediately to changes in power level to reduce total test time.
3. Use PK detector to test.

9.5. Uncertainty

The measurement uncertainty is defined as ± 1.27 dB

9.6. Test Result

Power output test was verified over all data rates of each mode shown as below, and then choose the maximum power output (blue marker) for final test of each channel.

Power output at various data rates:

Test Mode	Bandwidth	Frequency (MHz)	Channel	Data Rate	Peak Power (dBm)
802.11b	20	2437	6	1	24.93
				5.5	24.88
				11	24.81
802.11g	20	2437	6	6	22.98
				24	22.89
				54	22.83
802.11n	20	2437	6	MCS0	21.99
				MCS4	21.93
				MCS7	21.85
802.11n	40	2437	6	MCS0	21.45
				MCS4	21.33
				MCS7	21.35

Product	:	Wi-Fi Module
Test Item	:	Power Output
Test Site	:	TR8
Test Mode	:	Mode 1: Transmit by 802.11b

Ant 0

Channel No.	Frequency (MHz)	Measurement Power Output (dBm)		Total Power (dBm)	Limit (dBm)	Result
		Ant 1	Ant 2			
1	2412	15.38	N/A	15.38	30.00	Pass
6	2437	24.93	N/A	24.93	30.00	Pass
11	2462	15.67	N/A	15.67	30.00	Pass

Ant 1

Channel No.	Frequency (MHz)	Measurement Power Output (dBm)		Total Power (dBm)	Limit (dBm)	Result
		Ant 1	Ant 2			
1	2412	N/A	15.26	15.26	30.00	Pass
6	2437	N/A	23.78	23.78	30.00	Pass
11	2462	N/A	15.34	15.34	30.00	Pass

Product	:	Wi-Fi Module
Test Item	:	Power Output
Test Site	:	TR8
Test Mode	:	Mode 2: Transmit by 802.11g

Ant 0

Channel No.	Frequency (MHz)	Measurement Power Output (dBm)		Total Power (dBm)	Limit (dBm)	Result
		Ant 1	Ant 2			
1	2412	20.64	N/A	20.64	30.00	Pass
6	2437	22.98	N/A	22.98	30.00	Pass
11	2462	21.27	N/A	21.27	30.00	Pass

Ant 1

Channel No.	Frequency (MHz)	Measurement Power Output (dBm)		Total Power (dBm)	Limit (dBm)	Result
		Ant 1	Ant 2			
1	2412	N/A	20.32	20.32	30.00	Pass
6	2437	N/A	22.87	22.87	30.00	Pass
11	2462	N/A	21.06	21.06	30.00	Pass

Product	:	Wi-Fi Module
Test Item	:	Power Output
Test Site	:	TR8
Test Mode	:	Mode 3: Transmit by 802.11n(20MHz)

Ant 0

Channel No.	Frequency (MHz)	Measurement Power Output (dBm)		Total Power (dBm)	Limit (dBm)	Result
		Ant 1	Ant 2			
1	2412	20.83	N/A	20.83	30.00	Pass
6	2437	21.99	N/A	21.99	30.00	Pass
11	2462	21.03	N/A	21.03	30.00	Pass

Ant 1

Channel No.	Frequency (MHz)	Measurement Power Output (dBm)		Total Power (dBm)	Limit (dBm)	Result
		Ant 1	Ant 2			
1	2412	N/A	20.55	20.55	30.00	Pass
6	2437	N/A	21.86	21.86	30.00	Pass
11	2462	N/A	20.94	20.94	30.00	Pass

Product	:	Wi-Fi Module
Test Item	:	Power Output
Test Site	:	TR8
Test Mode	:	Mode 4: Transmit by 802.11n(40MHz)

Ant 0

Channel No.	Frequency (MHz)	Measurement Power Output (dBm)		Total Power (dBm)	Limit (dBm)	Result
		Ant 1	Ant 2			
3	2422	21.36	N/A	21.36	30.00	Pass
6	2437	21.45	N/A	21.45	30.00	Pass
9	2452	21.48	N/A	21.48	30.00	Pass

Ant 1

Channel No.	Frequency (MHz)	Measurement Power Output (dBm)		Total Power (dBm)	Limit (dBm)	Result
		Ant 1	Ant 2			
3	2422	N/A	21.28	21.28	30.00	Pass
6	2437	N/A	21.44	21.44	30.00	Pass
9	2452	N/A	21.37	21.37	30.00	Pass

10. Power Spectral Density

10.1. Test Equipment

Power Spectral Density / TR-8

Instrument	Manufacturer	Type No.	Serial No.	Cal. Due Date
Spectrum Analyzer	Agilent	N9010A	MY48030494	2016.03.10
Temperature/Humidity Meter	zhicheng	ZC1-2	TR8-TH	2016.04.09

Note: All equipments are calibrated with traceable calibrations. Each calibration is traceable to the national or international standards.

10.2. Test Setup

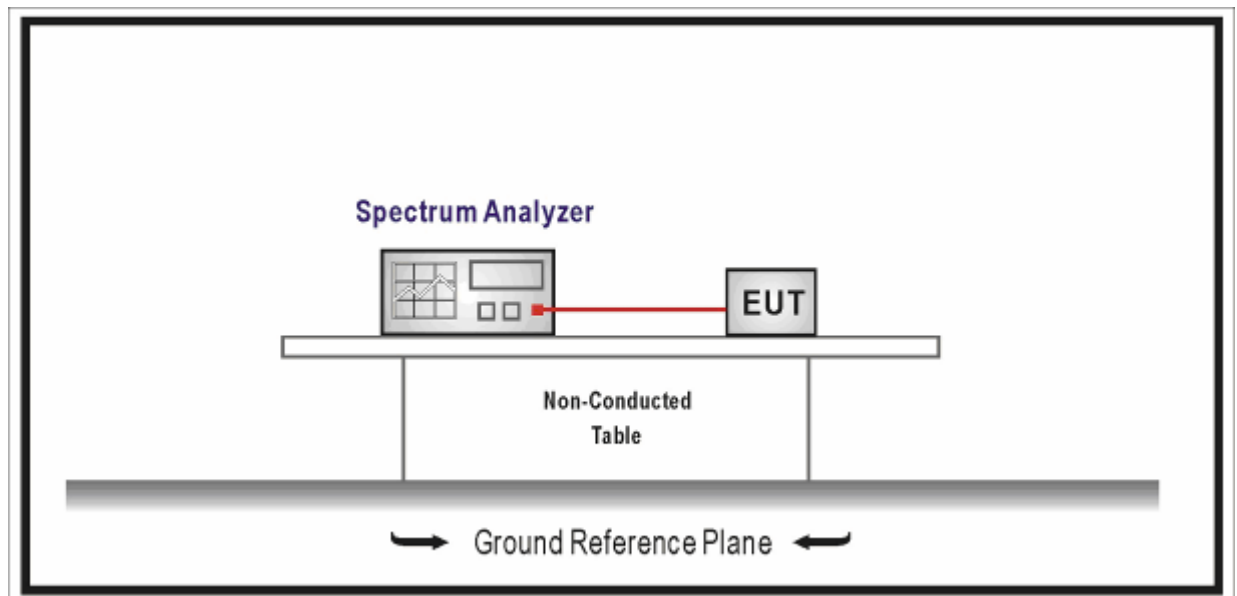

10.3. Limit

For FCC&IC

For digitally modulated systems, the power spectral density conducted from the intentional radiated to the Antenna shall not be greater than 8dBm in any 3kHz band during any time interval of continuous transmission.

10.4. Test Procedure

According to ANSI C63.4: 2014 & ANSI C63.10: 2013& FCC 47CFR 15.247& KDB 558074 D01v03r03& Industry Canada RSS-Gen Issue 4& RSS-247 Issue 1

- a) Set analyzer center frequency to DTS channel center frequency.
- b) Set the span to 1.5 times the DTS bandwidth.
- c) Set the RBW to: $3 \text{ kHz} \leq \text{RBW} \leq 100 \text{ kHz}$. (Actually we use 3kHz RBW)
- d) Set the VBW $\geq 3 \times \text{RBW}$.
- e) Detector = peak.
- f) Sweep time = auto couple.
- g) Trace mode = max hold.
- h) Allow trace to fully stabilize.
- i) Use the peak marker function to determine the maximum amplitude level within the band.
- j) If measured value exceeds limit, reduce RBW (no less than 3 kHz) and repeat.

10.5. Uncertainty

The measurement uncertainty is defined as $\pm 1.27 \text{ dB}$

10.6. Test Result

Product	:	Wi-Fi Module
Test Item	:	Power Spectral Density
Test Site	:	TR-8
Test Mode	:	Mode 1: Transmit by 802.11b

Channel No.	Frequency (MHz)	Measurement PPSD (dBm)		Limit (dBm)	Result
		Ant 0	Ant 1		
01	2412	-7.644	-7.718	8	Pass
06	2437	-7.825	-7.732	8	Pass
11	2462	-6.926	-7.860	8	Pass

Ant 0

Channel 01 (2412MHz)



Channel 06 (2437MHz)



Channel 11 (2462MHz)



Ant 1
Channel 01 (2412MHz)



Channel 06 (2437MHz)



Channel 11 (2462MHz)



Product	:	Wi-Fi Module
Test Item	:	Power Spectral Density
Test Site	:	TR-8
Test Mode	:	Mode 2: Transmit by 802.11g

Channel No.	Frequency (MHz)	Measurement PPSD (dBm)		Limit (dBm)	Result
		Ant 0	Ant 1		
01	2412	-15.103	-14.858	8	Pass
06	2437	-10.691	-10.950	8	Pass
11	2462	-12.783	-14.154	8	Pass

Ant 0

Channel 01 (2412MHz)

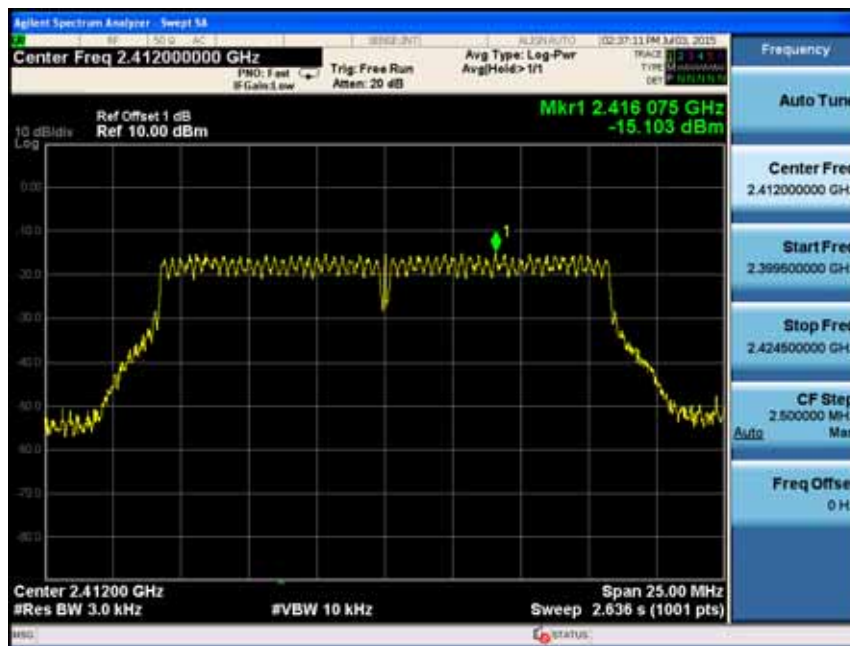

Channel 06 (2437MHz)

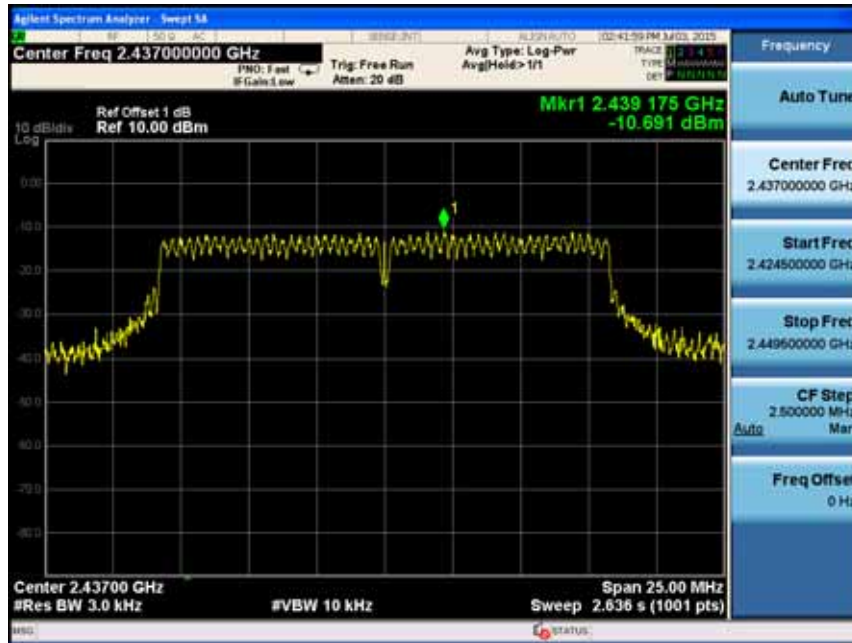

Channel 11 (2462MHz)

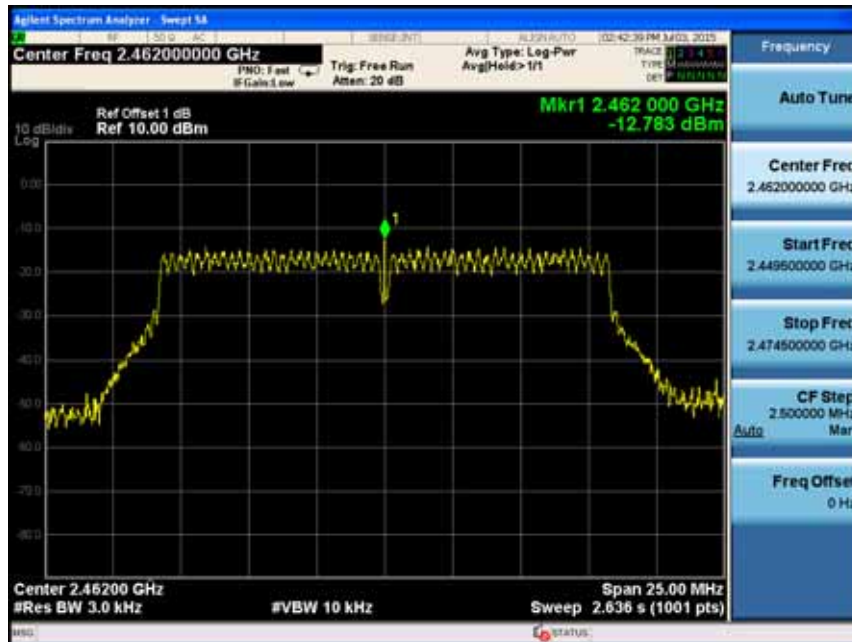

Ant 1
Channel 01 (2412MHz)

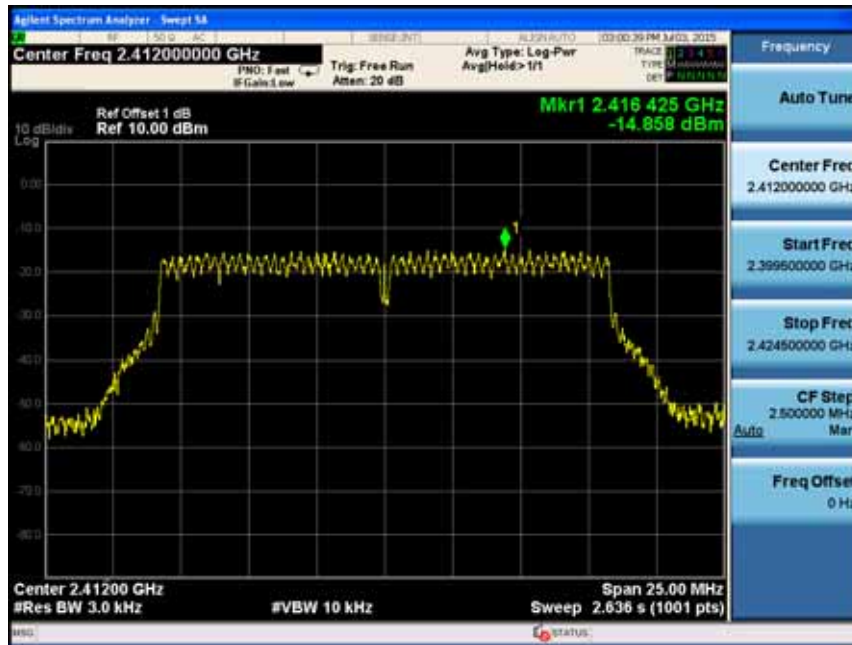

Channel 06 (2437MHz)



Channel 11 (2462MHz)

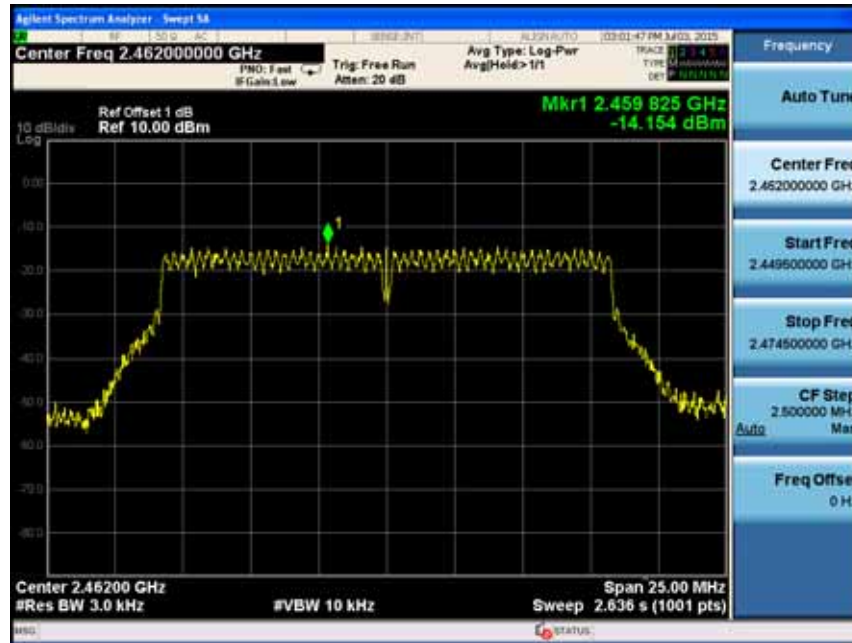

Product	:	Wi-Fi Module
Test Item	:	Power Spectral Density
Test Site	:	TR-8
Test Mode	:	Mode 3: Transmit by 802.11n(20MHz)

Channel No.	Frequency (MHz)	Measurement PPSD (dBm)		Limit (dBm)	Result
		Ant 0	Ant 1		
01	2412	-14.753	-14.701	8	Pass
06	2437	-12.514	-11.344	8	Pass
11	2462	-13.063	-14.604	8	Pass

Ant 0

Channel 01 (2412MHz)

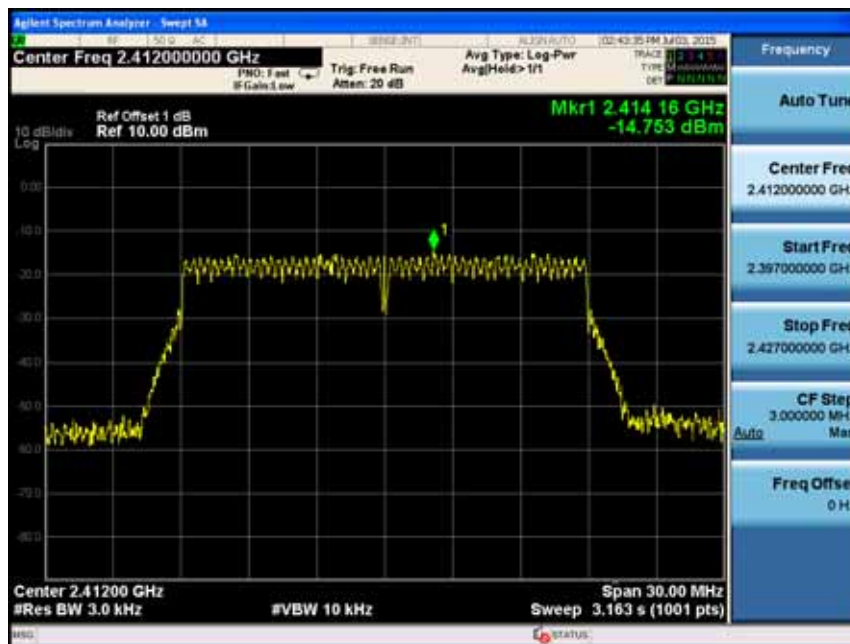

Channel 06 (2437MHz)



Channel 11 (2462MHz)

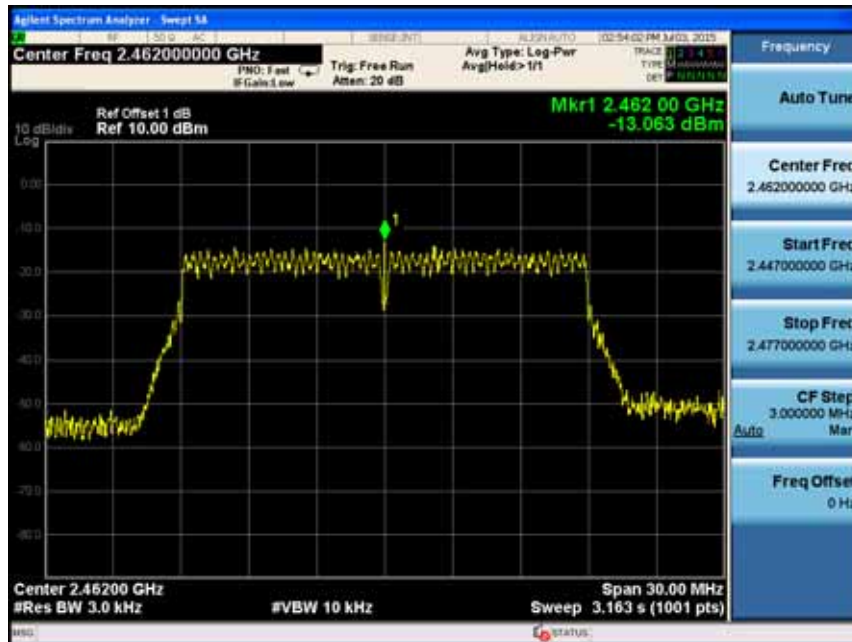

Ant 1
Channel 01 (2412MHz)



Channel 06 (2437MHz)

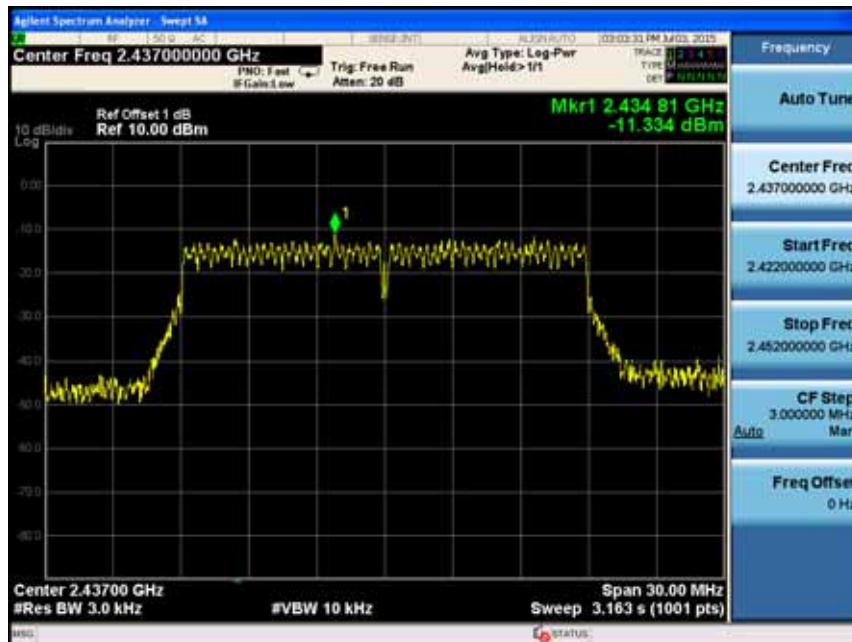

Channel 11 (2462MHz)

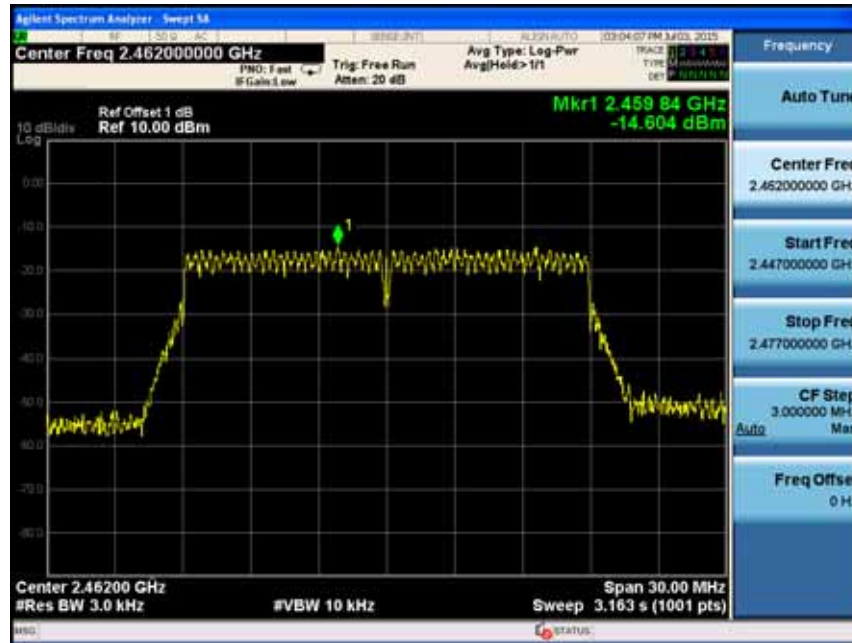

Product	:	Wi-Fi Module
Test Item	:	Power Spectral Density
Test Site	:	TR-8
Test Mode	:	Mode 4: Transmit by 802.11n(40MHz)

Channel No.	Frequency (MHz)	Measurement PPSD (dBm)		Limit (dBm)	Result
		Ant 0	Ant 1		
03	2422	-19.622	-18.221	8	Pass
06	2437	-14.480	-14.248	8	Pass
09	2452	-14.001	-14.811	8	Pass

Ant 0

Channel 03 (2422MHz)



Channel 06 (2437MHz)



Channel 09 (2452MHz)

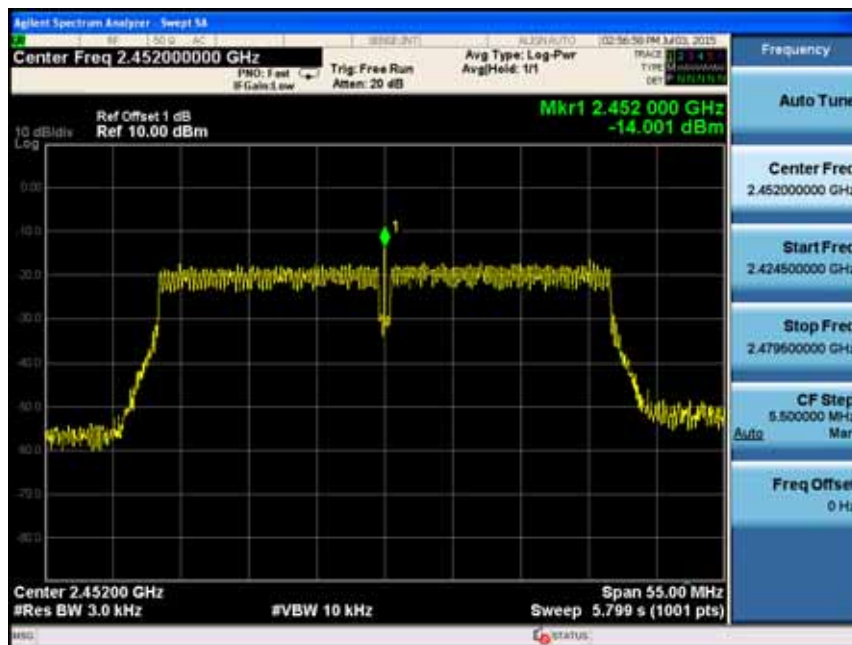

Ant 1
Channel 03 (2422MHz)

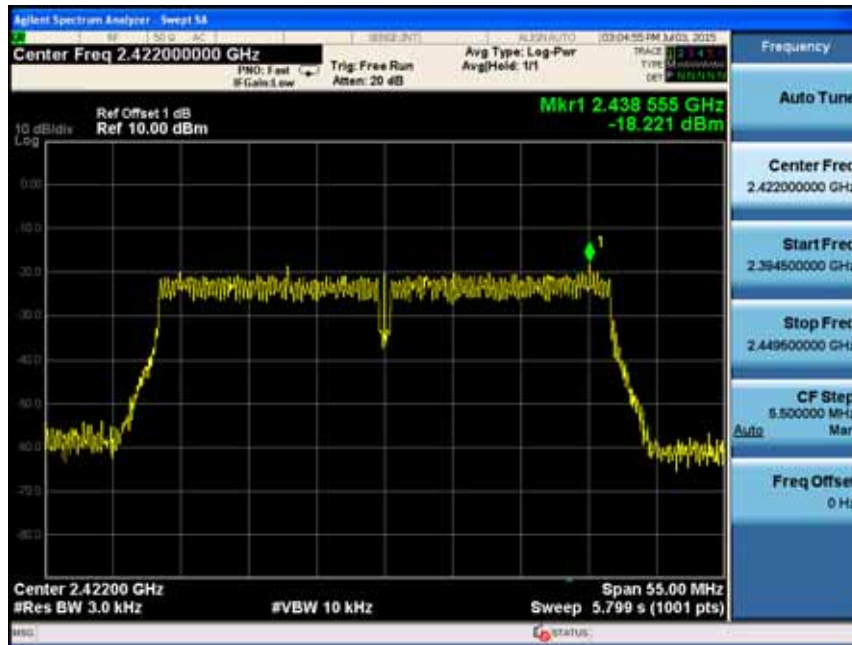

Channel 06 (2437MHz)

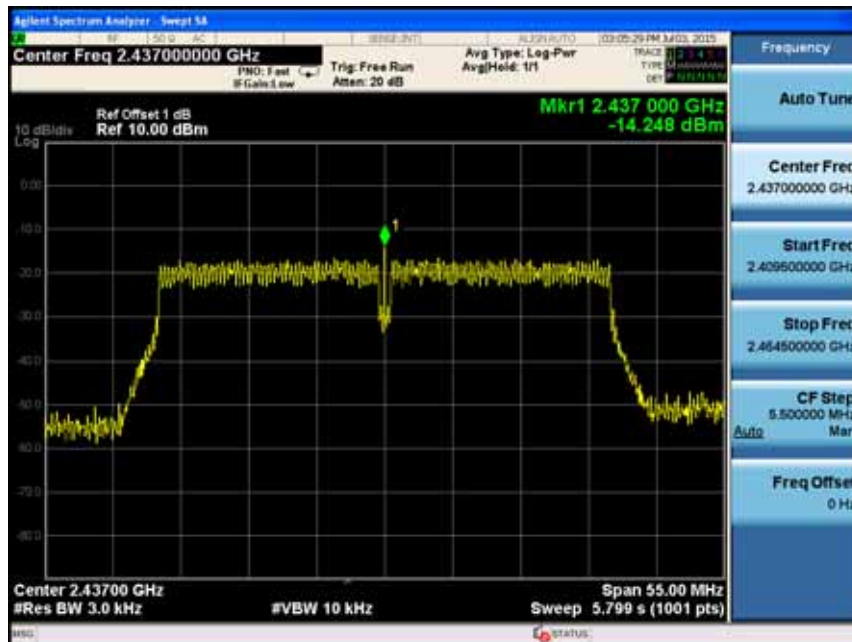

Channel 09 (2452MHz)

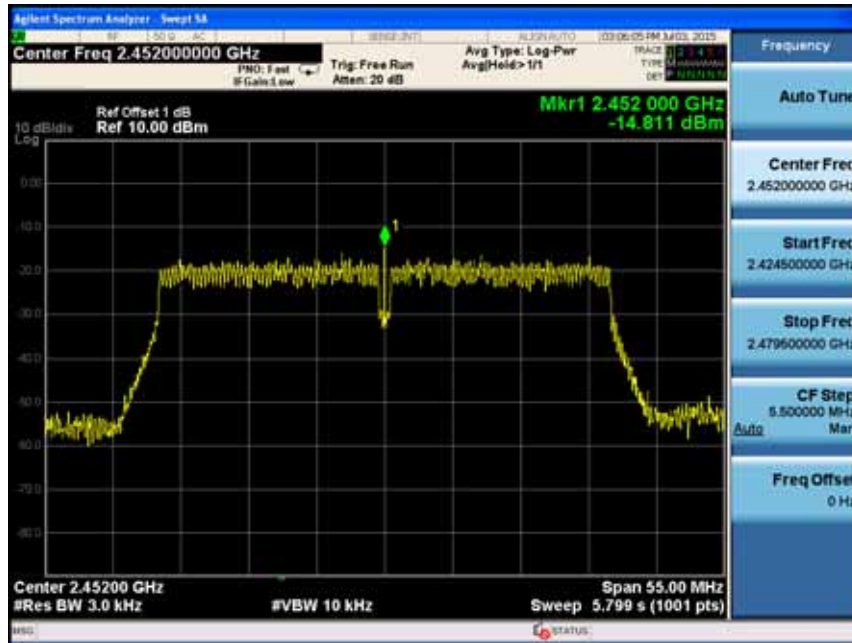

The End