

Test Report

FCC Part15 Subpart C

Product Name : Zipp
Model No. : LTH300
FCC ID : Y2SLTH300
IC ID : 9452A-LTH300

Applicant : LIBRATONE A/S
Address : Marielundvej 43A, DK-2730 Herlev, Denmark

Date of Receipt : Dec. 09, 2015
Test Date : Dec. 10, 2015~ Dec. 24, 2015
Issued Date : Jan. 04, 2016
Report No. : 15C2023R-RF-US-P06V01
Report Version : V 1.1

The test results relate only to the samples tested.

The test results shown in the test report are traceable to the national/international standard through the calibration of the equipment and evaluated measurement uncertainty herein.

This report must not be used to claim product endorsement by any agency of the government.

The test report shall not be reproduced without the written approval of QuieTek Corporation.

Test Report Certification

Issued Date : Jan. 04, 2016

Report No. : 15C2023R-RF-US-P06V01



Product Name : Zipp
Applicant : LIBRATONE A/S
Address : Marielundvej 43A, DK-2730 Herlev, Denmark
Manufacturer : Goertek Inc
Address : No 268 Dongfang Rd., New&high-tech Industry Development Zone Weifang Shandong Province 261031, PRC.
Model No. : LTH300
EUT Voltage : AC 100~240V, 50/60Hz, 1.0A
Brand Name : LIBRATONE
FCC ID : Y2SLTH300
IC ID : 9452A-LTH300
Applicable Standard : FCC CFR Title 47 Part 15 Subpart C: 2015
ANSI C63.4: 2014; ANSI C63.10: 2013
Industry Canada RSS-Gen Issue 4/RSS-247 Issue 1
Test Result : Complied
Performed Location : Suzhou EMC Laboratory
No.99 Hongye Rd., Suzhou Industrial Park, Suzhou,215006, Jiangsu, China
TEL: +86-512-6251-5088 / FAX: +86-512-6251-5098
FCC Registration Number: 800392; IC Lab Code: 4075B

Documented By

: 
Elaine Wang Senior Engineer

Reviewed By

: 
Jack Zhang Senior Engineer

Approved By

: 
Harry Zhao RF Engineering Manager

Laboratory Information

We, **Quietek Corporation**, are an independent EMC and safety consultancy that was established the whole facility in our laboratories. The test facility has been accredited/accepted(audited or listed) by the following related bodies in compliance with ISO 17025, EN 45001 and specified testing scope:

Taiwan R.O.C.	:	BSMI, NCC,TAF
USA	:	FCC
Japan	:	VCCI
China	:	CNAS

The related certificate for our laboratories about the test site and management system can be downloaded from Quietek Corporation's Web Site :<http://www.quietek.com/tw/ctg/cts/accreditations.htm>

The address and introduction of Quietek Corporation's laboratories can be founded in our Web site :
<http://www.quietek.com/>

If you have any comments, Please don't hesitate to contact us. Our contact information is as below:

HsinChu Testing Laboratory :

No.75-2, 3rd Lin, Wangye Keng, Yonghxing Tsuen, Qionglin Shiang, Hsinchu County 307, Taiwan, R.O.C.
TEL:+886-3-592-8858 / FAX:+886-3-592-8859 E-Mail : service@quietek.com

LinKou Testing Laboratory :

No.5-22, Ruishukeng, Linkou Dist., New Taipei City 24451, Taiwan, R.O.C.
TEL : 886-2-8601-3788 / FAX : 886-2-8601-3789 E-Mail : service@quietek.com

Suzhou Testing Laboratory :

No.99 Hongye Rd., Suzhou Industrial Park, Suzhou, 215006, Jiangsu, China
TEL : +86-512-6251-5088 / FAX : 86-512-6251-5098 E-Mail : service@quietek.com

TABLE OF CONTENTS

Description	Page
1. General Information.....	6
1.1. EUT Description	6
1.1. Mode of Operation	9
1.2. Tested System Details.....	10
1.3. Configuration of Tested System	11
1.4. EUT Exercise Software	12
2. Technical Test.....	13
2.1. Summary of Test Result	13
2.2. Test Environment	14
3. Radiated Emission	15
3.1. Test Equipment	15
3.2. Test Setup	16
3.3. Limit.....	17
3.4. Test Procedure	17
3.5. Uncertainty	18
3.6. Test Result	19
4. Peak Output Power	24
4.1. Test Equipment	24
4.2. Test Setup	24
4.3. Limit.....	24
4.4. Test Procedure	25
4.5. Uncertainty	25
4.6. Test Result	26
5. Radiated Emission Band Edge.....	32
5.1. Test Equipment	32
5.2. Test Setup	33
5.3. Limit.....	33
5.4. Test Procedure	34
5.5. Uncertainty	35
5.6. Test Result	35

History of This Test Report

REPORT NO.	VERSION	DESCRIPTION	ISSUED DATE
15C2023R-RF-US-P06V01	V1.0	Initial Issued Report	Dec. 25, 2015
15C2023R-RF-US-P06V01	V1.1	Add item of power output	Jan. 04, 2016

1. General Information

1.1. EUT Description

Product Name	Zipp
Brand Name	LIBRATONE
Model No.	LTH300
Working Voltage	AC 100~240V, 50/60Hz, 1.0A
Bluetooth Specification	3.0 + Version 4.0
Frequency Range	2402- 2480 MHz
Channel Number	V3.0+HS: 79 V4.0: 40
Channel Separation	V3.0+HS: 1MHz V4.0: 2MHz
Type of Modulation	V3.0: GFSK, Pi/4 DQPSK, 8DPSK V4.0: GFSK
Data Rate	V3.0: 1Mbps(GFSK), 2Mbps(Pi/4 DQPSK), 3Mbps (8DPSK) V4.0: 1Mbps
Antenna Type	Reference to Antenna List
Peak Antenna Gain	Reference to Antenna List

Note: This report was based on Quietek report No: 1560645R. This is to verify metal cover for top and bottom enclosure as 2nd enclosure source.

Bluetooth Working Frequency of Each Channel: (For V3.0)							
Channel	Frequency	Channel	Frequency	Channel	Frequency	Channel	Frequency
00	2402 MHz	01	2403 MHz	02	2404 MHz	03	2405 MHz
04	2406 MHz	05	2407 MHz	06	2408 MHz	07	2409 MHz
08	2410 MHz	09	2411 MHz	10	2412 MHz	11	2413 MHz
12	2414 MHz	13	2415 MHz	14	2416 MHz	15	2417 MHz
16	2418 MHz	17	2419 MHz	18	2420 MHz	19	2421 MHz
20	2422 MHz	21	2423 MHz	22	2424 MHz	23	2425 MHz
24	2426 MHz	25	2427 MHz	26	2428 MHz	27	2429 MHz
28	2430 MHz	29	2431 MHz	30	2432 MHz	31	2433 MHz
32	2434 MHz	33	2435 MHz	34	2436 MHz	35	2437 MHz
36	2438 MHz	37	2439 MHz	38	2440 MHz	39	2441 MHz
40	2442 MHz	41	2443 MHz	42	2444 MHz	43	2445 MHz
44	2446 MHz	45	2447 MHz	46	2448 MHz	47	2449 MHz
48	2450 MHz	49	2451 MHz	50	2452 MHz	51	2453 MHz
52	2454 MHz	53	2455 MHz	54	2456 MHz	55	2457 MHz
56	2458 MHz	57	2459 MHz	58	2460 MHz	59	2461 MHz
60	2462 MHz	61	2463 MHz	62	2464 MHz	63	2465 MHz
64	2466 MHz	65	2467 MHz	66	2468 MHz	67	2469 MHz
68	2470 MHz	69	2471 MHz	70	2472 MHz	71	2473 MHz
72	2474 MHz	73	2475 MHz	74	2476 MHz	75	2477 MHz
76	2478 MHz	77	2479 MHz	78	2480 MHz	N/A	N/A

Bluetooth Working Frequency of Each Channel: (For V4.0)							
Channel	Frequency	Channel	Frequency	Channel	Frequency	Channel	Frequency
00	2402 MHz	01	2404 MHz	02	2406 MHz	03	2408 MHz
04	2410 MHz	05	2412 MHz	06	2414 MHz	07	2416 MHz
08	2418 MHz	09	2420 MHz	10	2422 MHz	11	2424 MHz
12	2426 MHz	13	2428 MHz	14	2430 MHz	15	2432 MHz
16	2434 MHz	17	2436 MHz	18	2438 MHz	19	2440 MHz
20	2442 MHz	21	2444 MHz	22	2446 MHz	23	2448 MHz
24	2450 MHz	25	2452 MHz	26	2454 MHz	27	2456 MHz
28	2458 MHz	29	2460 MHz	30	2462 MHz	31	2464 MHz
32	2466 MHz	33	2468 MHz	34	2470 MHz	35	2472 MHz
36	2474 MHz	37	2476 MHz	38	2478 MHz	39	2480 MHz

Bluetooth Antenna List

Antenna	Manufacturer	Model No.	Peak Gain
PIFA Antenna	Goertek	N/A	1.2dBi for 2.4GHz

1.1. Mode of Operation

QuieTek has verified the construction and function in typical operation. All the test modes were carried out with the EUT in normal operation, which was shown in this test report and defined as:

Test Mode
Mode 1: Transmitter-1Mbps(GFSK_DH5)
Mode 2: Transmitter-2Mbps(Pi/4 DQPSK_DH5)
Mode 3: Transmitter-3Mbps(8DPSK_DH5)

Note:

1. Regards to the frequency band operation: the lowest, middle and highest frequency of channel were selected to perform the test, then shown on this report.
2. For portable device, radiated spurious emission was verified over X, Y, Z axis, and shown the worst case on this report.

1.2. Tested System Details

The types for all equipments, plus descriptions of all cables used in the tested system (including inserted cards) are:

Product	Manufacturer	Model No.	Serial No.	Power Cord
1 Notebook	Asus	N80V	8BN0AS226971468	N/A

1.3. Configuration of Tested System

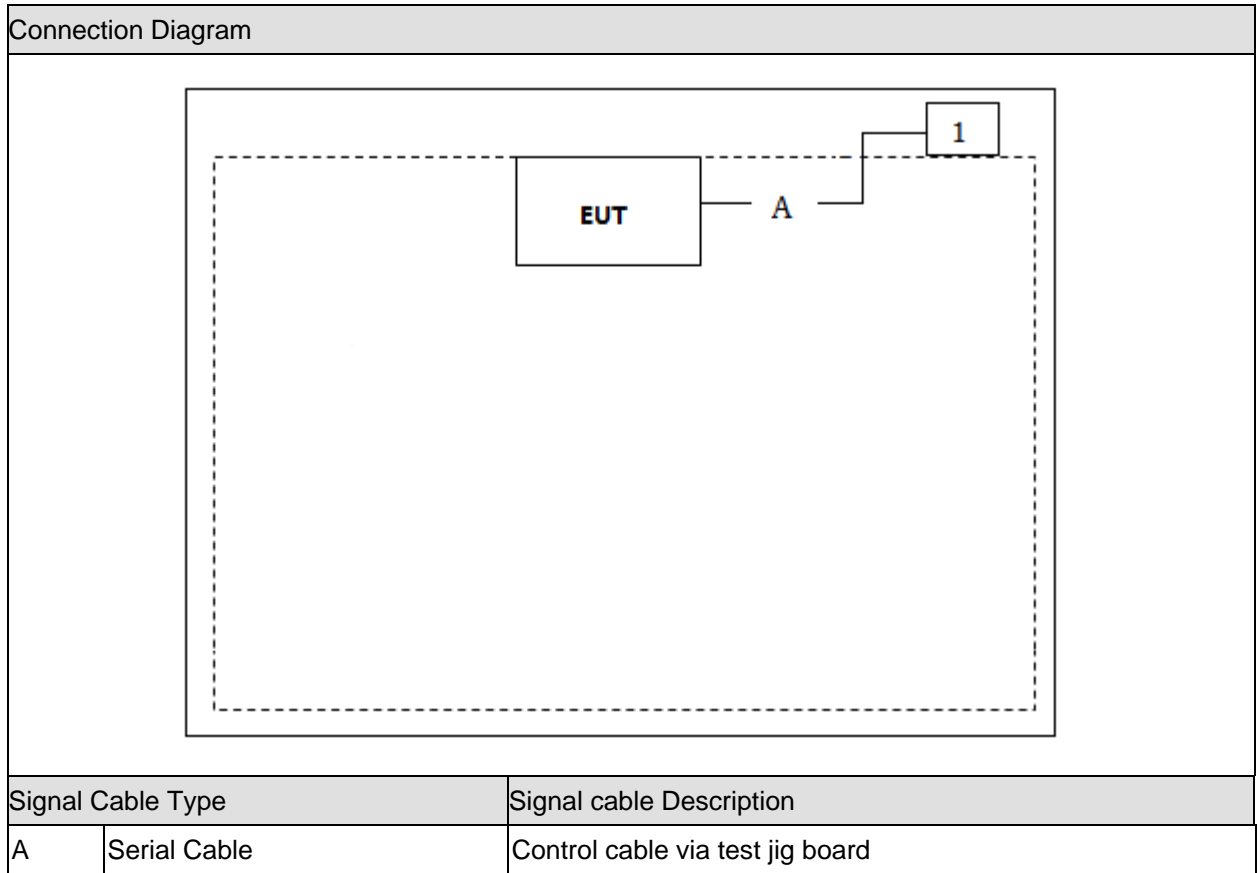

1.4. EUT Exercise Software

1	Setup the EUT and simulators as shown on above.
2	Turn on the power of all equipment.
3	Input the RF commands, and set the test mode and channel, then press OK to start continue Transmit.

2. Technical Test

2.1. Summary of Test Result

No deviations from the test standards

Deviations from the test standards as below description:

For FCC

Performed Test Item	Normative References	Test Performed	Deviation
Radiated Emission	FCC CFR Title 47 Part 15 Subpart C: 2015 Section 15.209	Yes	No
Power Output	FCC CFR Title 47 Part 15 Subpart C: 2015 Section 15.247(b)(3)	Yes	No
Radiated Emission Band Edge	FCC CFR Title 47 Part 15 Subpart C: 2015 15.247(d)	Yes	No

For IC

Performed Test Item	Normative References	Test Performed	Deviation
Radiated Emission	RSS-247 Issue 1 May 2015 Section 5.5	Yes	No
Power Output	RSS-247 Issue 1 May 2015 Section 5.4	Yes	No
Radiated Emission Band Edge	RSS-Gen Issue 4 November 2014 Section 8.10	Yes	No

2.2. Test Environment

Items	Required (IEC 68-1)	Actual
Temperature (°C)	15-35	21
Humidity (%RH)	25-75	50
Barometric pressure (mbar)	860-1060	950-1000

3. Radiated Emission

3.1. Test Equipment

Radiated Emission / AC-2

Instrument	Manufacturer	Type No.	Serial No.	Cal. Due Date
EMI Test Receiver	R&S	ESCI	100573	2016.03.10
Loop Antenna	R&S	HFH2-Z2	833799/003	2016.11.25
Bilog Antenna	Teseq GmbH	CBL6112D	27611	2016.10.10
Coaxial Cable	Huber+Suhner	SUCOFLEX 106	AC2-C	2016.03.01
Temperature/Humidity Meter	Zhicheng	ZC1-2	AC2-TH	2016.01.07

Radiated Emission / AC-5

Instrument	Manufacturer	Type No.	Serial No.	Cal. Due Date
Spectrum Analyzer	Agilent	N9010A	MY48030494	2016.03.10
Preamplifier	Miteq	NSP1800-25	1364185	2016.05.03
Preamplifier	Quietek	AP-040G	CHM-0906001	2016.05.03
Bilog Antenna	Teseq GmbH	CBL6112D	27612	2016.10.15
Broad-Band Horn Antenna	Schwarzbeck	BBHA9120D	499	2016.06.08
Broad-Band Horn Antenna	Schwarzbeck	BBHA9170	294	2016.04.10
Coaxial Cable	Huber+Suhner	SUCOFLEX 106	AC5-C1	2016.03.01
Coaxial Cable	Huber+Suhner	SUCOFLEX 106	AC5-C2	2016.03.01
Coaxial Cable	Huber+Suhner	SUCOFLEX 102	AC5-C3	2016.03.01
Temperature/Humidity Meter	Zhicheng	ZC1-2	AC5-TH	2016.01.07

3.2. Test Setup

Below 30MHz Test Setup:

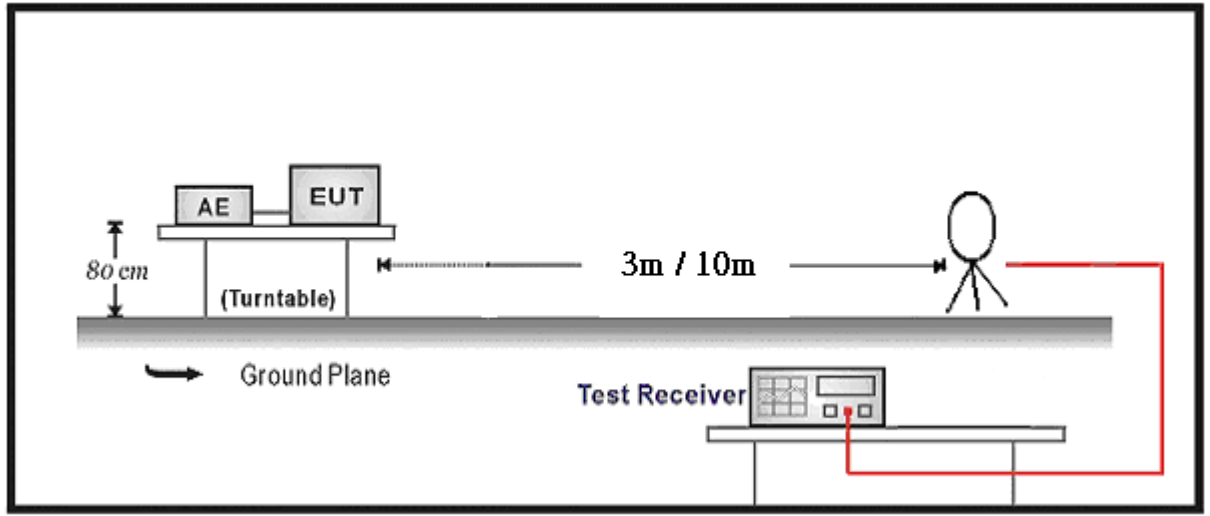

Below 1GHz Test Setup:

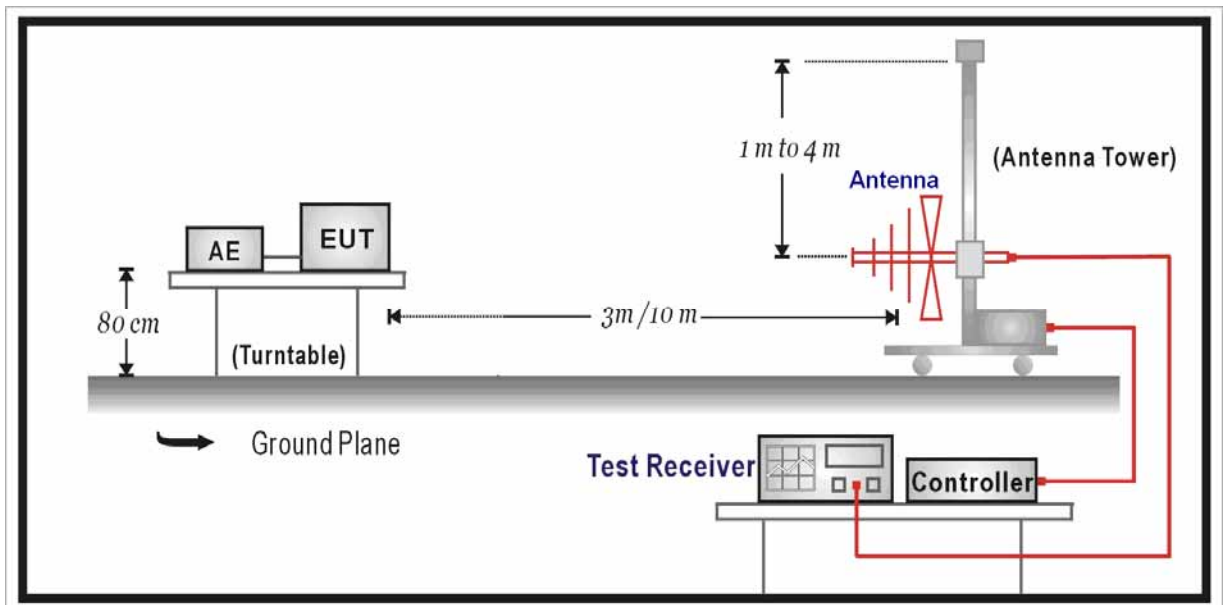

Above 1GHz Test Setup:

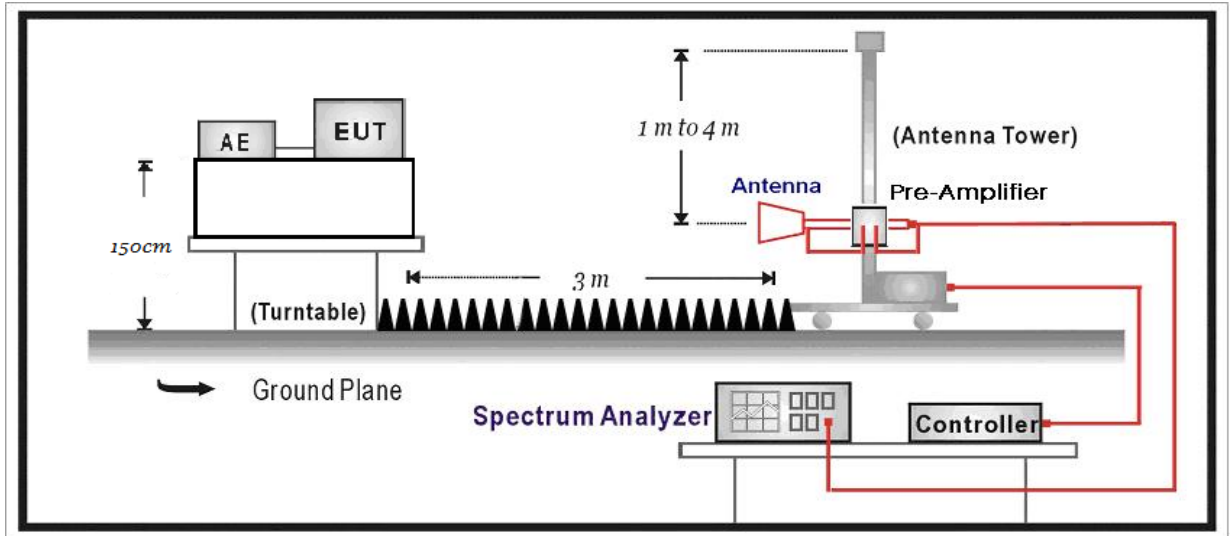

3.3. Limit

FCC Part 15 Subpart C Paragraph 15.209		
Frequency (MHz)	Distance (m)	Level (dBuV/m)
30 - 88	3	40
88 - 216	3	43.5
216 - 960	3	46
Above 960	3	54

Note 1: The lower limit shall apply at the transition frequency.

Note 2: Distance refers to the distance in meters between the measuring instrument antenna and the closed point of any part of the device or system.

Note 3: E field strength (dBuV/m) = 20 log E field strength (uV/m)

3.4. Test Procedure

According to ANSI C63.4: 2014; ANSI C63.10: 2013.

The EUT is placed on a turn table which is 1.5 meter for above 1G and 0.8 meter for below 1G above ground. The turn table is rotated 360 degrees to determine the position of the maximum emission level. The EUT was positioned such that the distance from antenna to the EUT was 3 meters.

The antenna is scanned from 1 meter to 4 meters to find out the maximum emission level.

This is repeated for both horizontal and vertical polarization of the antenna. In order to find the maximum emission, all of the interface cables were manipulated according to ANSI C63.4: 2014 on radiated measurement.

The resolution bandwidth below 1GHz setting on the field strength meter is 120 kHz and above 1GHz is 1MHz.

The frequency range from 30MHz to 10th harmonic is checked.

Note: When doing emission measurement above 1GHz, the horn antenna will be bended down a little (as horn antenna has the narrow beamwidth) in order to keeping the antenna in the “cone of radiation” of EUT. The 3dB beamwidth is 60~10 degrees for H-plane and 90~10 degrees for E-plane.

3.5. Uncertainty

The measurement uncertainty above 1G is defined as ± 3.9 dB
below 1G is defined as ± 3.8 dB

3.6. Test Result

All of the test result shown indicates the worst case, and spectrum analyzer parameters setting as shown below:

Peak detector: RBW = 1MHz, VBW = 3MHz, sweep time = 200ms;

Average detector: RBW = 1MHz, VBW = 10Hz, sweep time = auto.

Measure Level = Reading Level + Cable Loss + Antenna Factor – Preamplifier Gain

Mode 1: Transmitter-1Mbps(GFSK_DH5)

CH	Antenna	Frequency (MHz)	Reading Level (dBuV/m)	Factor (dB)	Measure Level (dBuV/m)	Limit (dBuV/m)	Margin (dB)	Detector
0	H	4799.5	35.8	7.7	43.5	54(Note3)	-10.5	PK
	V	4799.5	37.3	7.7	45.0	54(Note3)	-9.0	PK
	H	7206.0	28.2	12.6	40.8	54(Note3)	-13.2	PK
	V	7206.0	26.4	12.6	39.0	54(Note3)	-15.0	PK
	H	9608.0	25.9	15.1	41.0	54(Note3)	-13.0	PK
	V	9608.0	25.1	15.1	40.2	54(Note3)	-13.8	PK
39	H	4884.5	35.8	7.8	43.6	54(Note3)	-10.4	PK
	V	4884.5	35.7	7.8	43.5	54(Note3)	-10.5	PK
	H	7323.0	27.3	12.9	40.2	54(Note3)	-13.8	PK
	V	7323.0	26.6	12.9	39.5	54(Note3)	-14.5	PK
	H	9764.0	24.5	15.4	39.9	54(Note3)	-14.1	PK
	V	9764.0	26.2	15.4	41.6	54(Note3)	-12.4	PK
78	H	4961.0	32.0	7.9	39.9	54(Note3)	-14.1	PK
	V	4961.0	33.5	7.9	41.4	54(Note3)	-12.6	PK
	H	7440.0	28.4	13.3	41.7	54(Note3)	-12.3	PK
	V	7440.0	26.8	13.3	40.1	54(Note3)	-13.9	PK
	H	9920.0	24.2	14.9	39.1	54(Note3)	-14.9	PK
	V	9920.0	25.0	14.9	39.9	54(Note3)	-14.1	PK

Note: 1. Measure Level = Reading Level + Factor.

2. The test frequency range, 9kHz~30MHz, 18GHz~25GHz, both of the worst case are at least 6dB below the limits, therefore no data appear in the report.
3. This limit applies for using average detector, if the test result on peak is lower than average limit, then average measurement needn't be performed.

Mode 2: Transmitter-2Mbps(Pi/4 DQPSK _DH5)

CH	Antenna	Frequency (MHz)	Reading Level (dBuV/m)	Factor (dB)	Measure Level (dBuV/m)	Limit (dBuV/m)	Margin (dB)	Detector
0	H	4799.5	36.2	7.7	43.9	54(Note3)	-10.1	PK
	V	4808.0	34.7	7.7	42.4	54(Note3)	-11.6	PK
	H	7206.0	27.0	12.6	39.6	54(Note3)	-14.4	PK
	V	7206.0	26.7	12.6	39.3	54(Note3)	-14.7	PK
	H	9608.0	25.0	15.1	40.1	54(Note3)	-13.9	PK
	V	9608.0	24.9	15.1	40.0	54(Note3)	-14.0	PK
39	H	4884.5	32.7	7.8	40.5	54(Note3)	-13.5	PK
	V	4884.5	33.9	7.8	41.7	54(Note3)	-12.3	PK
	H	7323.0	26.7	12.9	39.6	54(Note3)	-14.4	PK
	V	7323.0	27.6	12.9	40.5	54(Note3)	-13.5	PK
	H	9764.0	25.6	15.4	41.0	54(Note3)	-13.0	PK
	V	9764.0	25.8	15.4	41.2	54(Note3)	-12.8	PK
78	H	4961.0	31.9	7.9	39.8	54(Note3)	-14.2	PK
	V	4961.0	32.9	7.9	40.8	54(Note3)	-13.2	PK
	H	7440.0	27.3	13.3	40.6	54(Note3)	-13.4	PK
	V	7440.0	27.3	13.3	40.6	54(Note3)	-13.4	PK
	H	9920.0	25.8	14.9	40.7	54(Note3)	-13.3	PK
	V	9920.0	25.4	14.9	40.3	54(Note3)	-13.7	PK

Note: 1. Measure Level = Reading Level + Factor.

2. The test frequency range, 9kHz~30MHz, 18GHz~25GHz, both of the worst case are at least 6dB below the limits, therefore no data appear in the report.
3. This limit applies for using average detector, if the test result on peak is lower than average limit, then average measurement needn't be performed.

Mode 3: Transmitter-3Mbps(8DPSK_DH5)

CH	Antenna	Frequency (MHz)	Reading Level (dBuV/m)	Factor (dB)	Measure Level (dBuV/m)	Limit (dBuV/m)	Margin (dB)	Detector
0	H	4808.0	35.0	7.7	42.7	54(Note3)	-9.5	PK
	V	4799.5	36.9	7.7	44.6	54(Note3)	-7.5	PK
	H	7206.0	26.4	12.6	39.0	54(Note3)	-13.0	PK
	V	7206.0	25.8	12.6	38.4	54(Note3)	-13.4	PK
	H	9608.0	24.5	15.1	39.6	54(Note3)	-12.8	PK
	V	9608.0	24.8	15.1	39.9	54(Note3)	-12.6	PK
39	H	4884.5	32.8	7.8	40.6	54(Note3)	-13.4	PK
	V	4884.5	34.0	7.8	41.8	54(Note3)	-12.2	PK
	H	7323.0	27.3	12.9	40.2	54(Note3)	-13.8	PK
	V	7323.0	26.9	12.9	39.8	54(Note3)	-14.2	PK
	H	9764.0	24.9	15.4	40.3	54(Note3)	-13.7	PK
	V	9764.0	25.4	15.4	40.8	54(Note3)	-13.2	PK
78	H	4960.0	31.2	8.0	39.2	54(Note3)	-14.8	PK
	V	4961.0	32.6	7.9	40.5	54(Note3)	-13.5	PK
	H	7440.0	26.7	13.3	40.0	54(Note3)	-14.0	PK
	V	7440.0	27.0	13.3	40.3	54(Note3)	-13.7	PK
	H	9920.0	25.0	14.9	39.9	54(Note3)	-14.1	PK
	V	9920.0	25.7	14.9	40.6	54(Note3)	-13.4	PK

Note: 1. Measure Level = Reading Level + Factor.

2. The test frequency range, 9kHz~30MHz, 18GHz~25GHz, both of the worst case are at least 6dB below the limits, therefore no data appear in the report.
3. This limit applies for using average detector, if the test result on peak is lower than average limit, then average measurement needn't be performed.

The worst case of Radiated Emission below 1GHz:

Engineer: Scott	
Site: AC2	Time: 2015/12/13
Limit: FCC_Part15.209_RE(3m)_ClassB	Margin: 0
Probe: AC2_10M(30-1000M)20150408	Polarity: Horizontal
EUT: Zipp	Power: AC 120V/60Hz
Note: Mode 1	

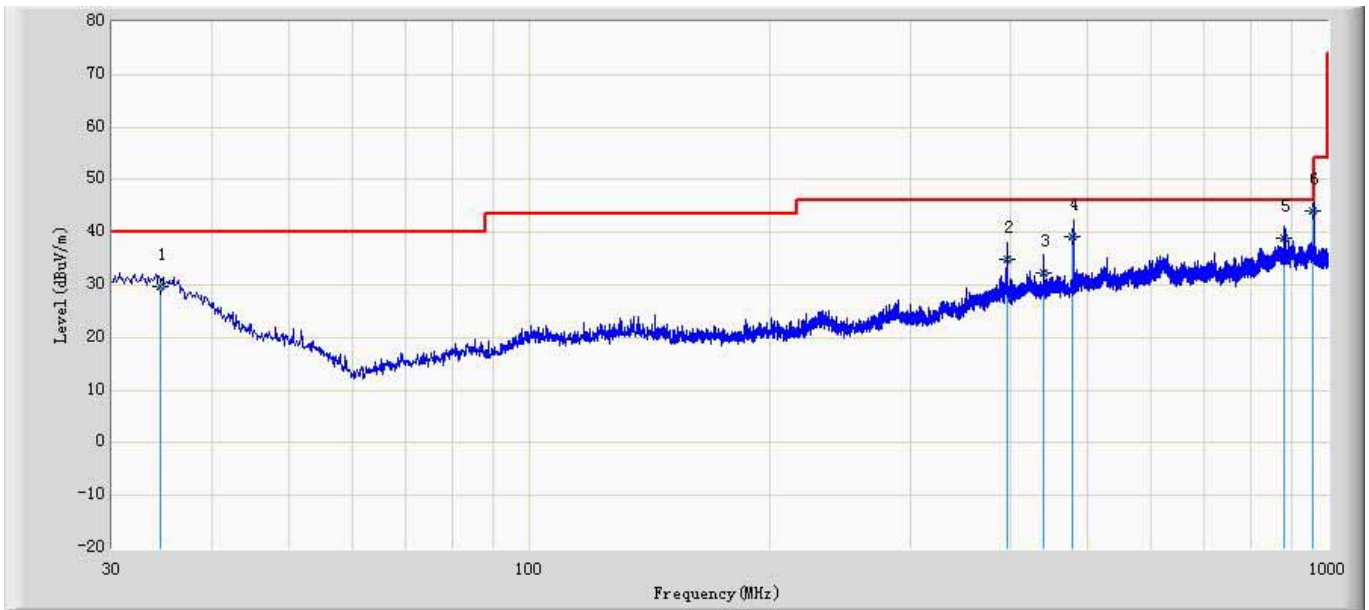

No	Mark	Frequency (MHz)	Measure Level (dBuV/m)	Reading Level (dBuV)	Over Limit (dB)	Limit (dBuV/m)	Factor (dB)	Type
1		34.540	29.759	36.119	-10.241	40.000	-6.360	QP
2		396.201	34.913	39.837	-11.087	46.000	-4.924	QP
3		440.121	32.436	36.164	-13.564	46.000	-3.728	QP
4		479.218	39.227	42.139	-6.773	46.000	-2.912	QP
5		883.011	39.025	37.993	-6.975	46.000	1.032	QP
6	*	959.120	43.977	41.876	-2.023	46.000	2.101	QP

Engineer: Scott	
Site: AC2	Time: 2015/12/13
Limit: FCC_Part15.209_RE(3m)_ClassB	Margin: 0
Probe: AC2_10M(30-1000M)20150408	Polarity: Vertical
EUT: Zipp	Power: AC 120V/60Hz
Note: Mode 1	

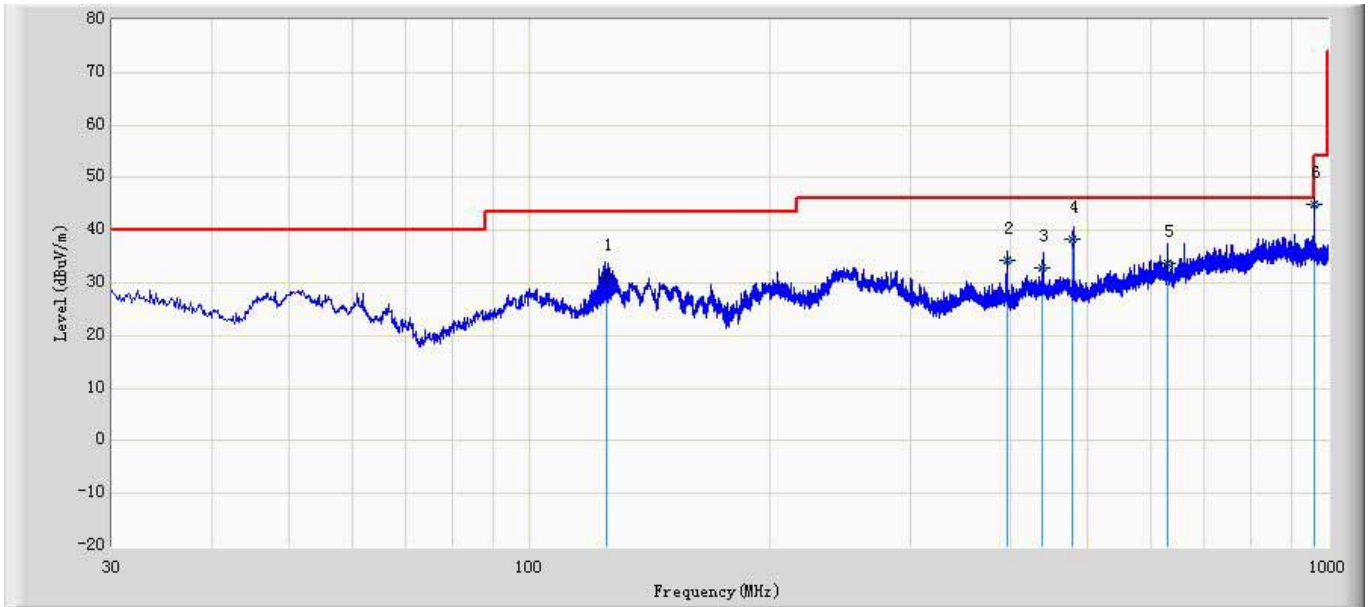

No	Mark	Frequency (MHz)	Measure Level (dBuV/m)	Reading Level (dBuV)	Over Limit (dB)	Limit (dBuV/m)	Factor (dB)	Type
1		124.900	31.041	40.717	-12.459	43.500	-9.676	QP
2		396.084	34.172	39.098	-11.828	46.000	-4.926	QP
3		439.044	32.761	36.516	-13.239	46.000	-3.755	QP
4		479.221	38.315	41.227	-7.685	46.000	-2.912	QP
5		630.001	33.857	34.586	-12.143	46.000	-0.729	QP
6	*	959.866	44.805	42.696	-1.195	46.000	2.109	QP

4. Peak Output Power

4.1. Test Equipment

Peak Output Power / TR-8

Instrument	Manufacturer	Type No.	Serial No.	Cal. Due Date
Spectrum Analyzer	Agilent	N9010A	MY48030494	2016.03.10
Temperature/Humidity Meter	Zhicheng	ZC1-2	TR8-TH	2016.04.09

Note: All equipments are calibrated with traceable calibrations. Each calibration is traceable to the national or international standards.

4.2. Test Setup

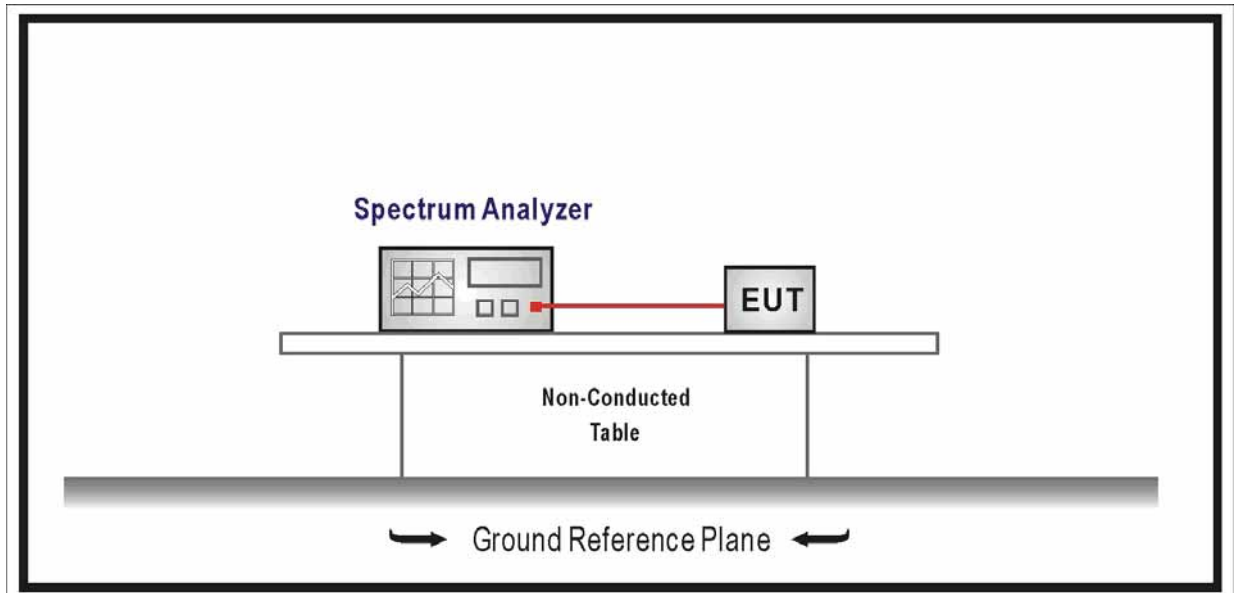

4.3. Limit

- For frequency hopping systems operating in the 2400-2483.5 MHz band employing at least 75 non-overlapping hopping channels, and all frequency hopping systems in the 5725-5850 MHz band: 1 watt. For all other frequency hopping systems in the 2400-2483.5 MHz band: 0.125 watts.
- For frequency hopping systems operating in the 902-928 MHz band: 1 watt for systems employing at least 50 hopping channels; and, 0.25 watts for systems employing less than 50 hopping channels, but at least 25 hopping channels.

Note: the conducted output power limit specified above is based on the use the antennas with

directional gains that do not exceed 6 dBi are used, the conducted output power from the intentional radiator shall be reduced below the stated values above, as appropriate, by the amount in dB that the directional gain of antenna exceeds 6 dBi.

4.4. Test Procedure

According to ANSI C63.10: 2013& ANSI C63.4: 2014

Use the following spectrum analyzer settings:

Span = approximately 5 times the 20dB bandwidth, centered on a hopping channel

RBW > the 20 dB bandwidth of the emission being measured.

VBW \cong RBW

Sweep = auto

Detector function = peak

Trace = max hold

Allow the trace to stabilize. Use the marker-to-peak function to set the marker to the peak of the emission. The indicated level is the peak output power (don't forget added the external attenuation and cable loss).

4.5. Uncertainty

The measurement uncertainty is defined as ± 1.0 dB

4.6. Test Result

Product	:	Zipp
Test Item	:	Power Output
Test Mode	:	Mode 1: Transmitter-1Mbps (GFSK_DH5)

Channel No.	Frequency (MHz)	Measurement Power Output (dBm)	Limit (dBm)	Result
0	2402	6.18	30.00	Pass
39	2441	6.40	30.00	Pass
78	2480	6.67	30.00	Pass

DH5 2402MHz

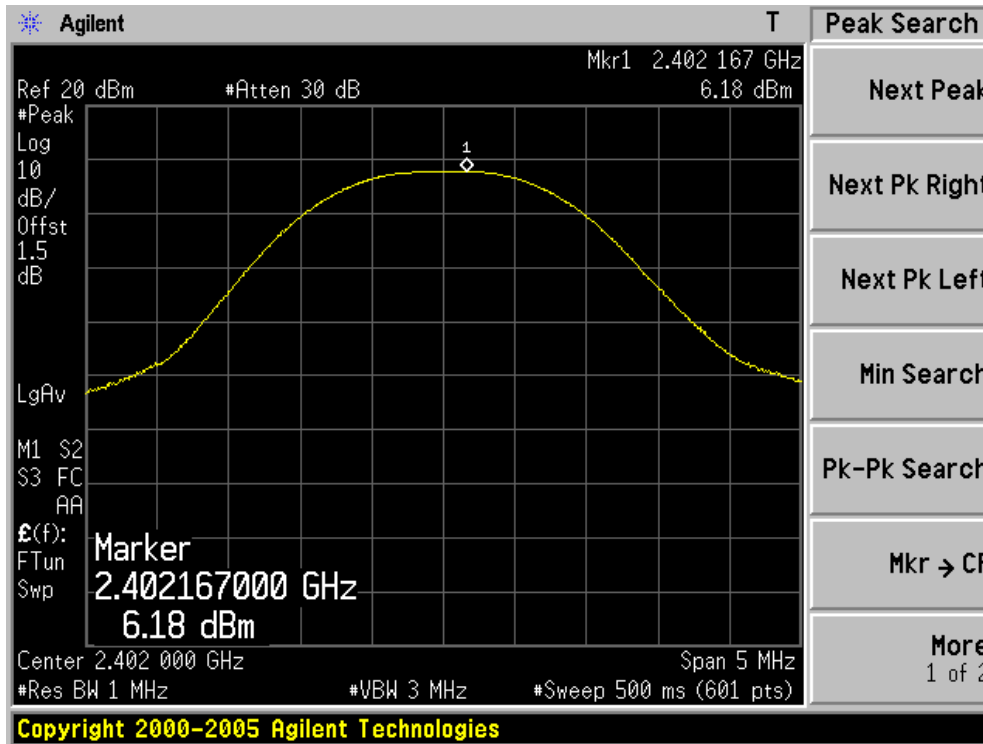

DH5 2441MHz

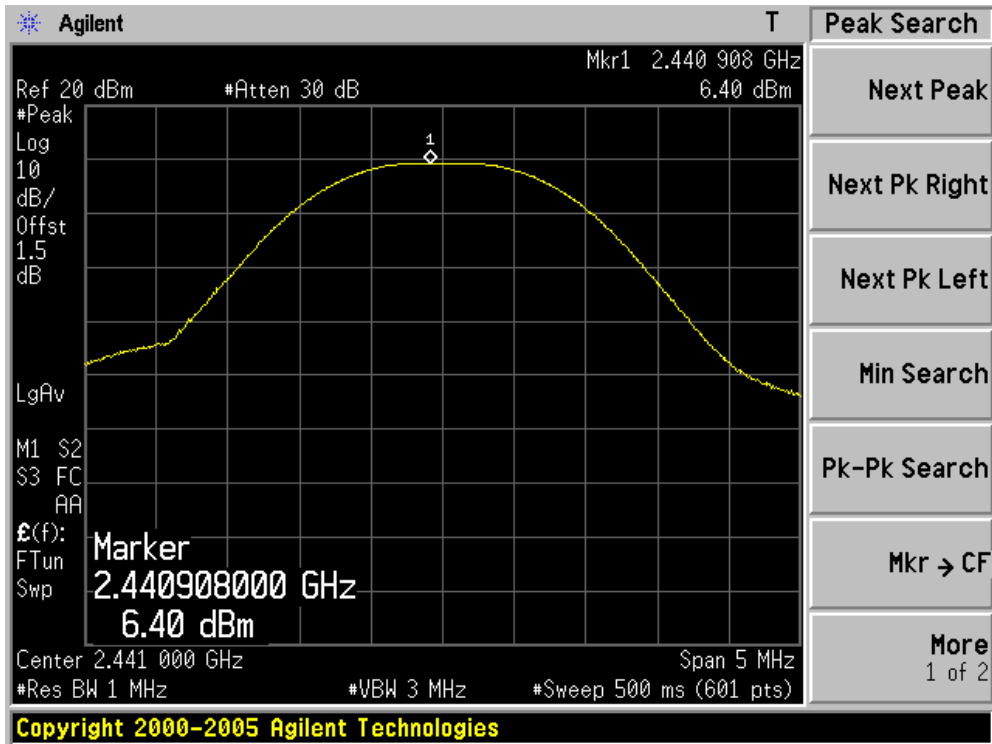

DH5 2480MHz

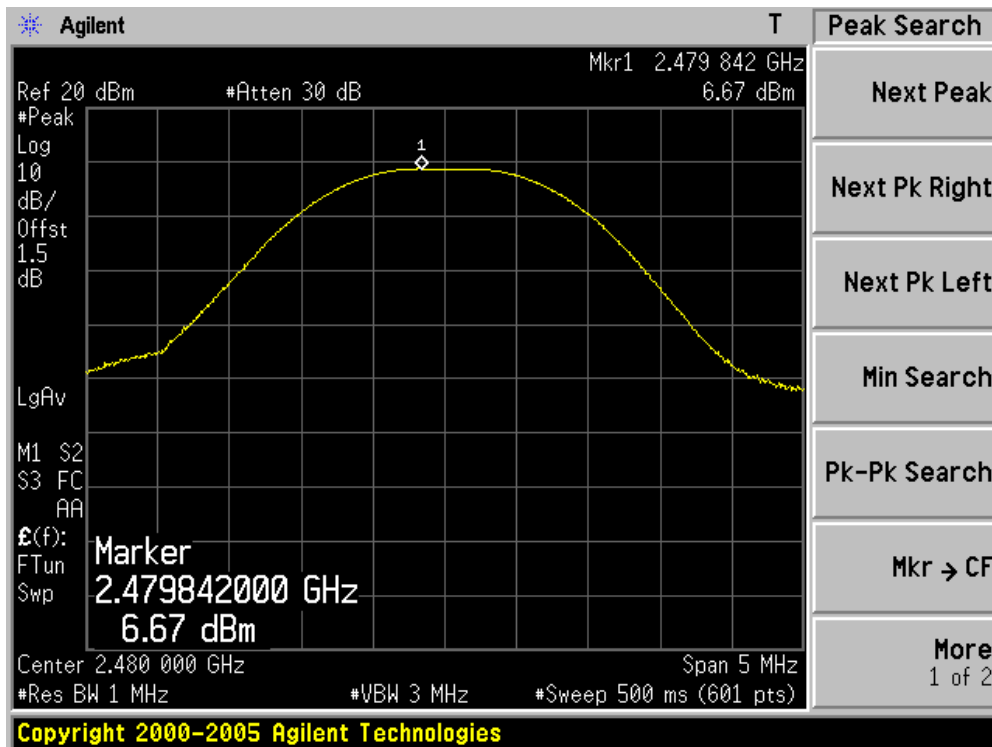

Product	: Zipp
Test Item	: Power Output
Test Mode	: Mode 2: Transmitter-2Mbps (Pi/4 DQPSK_DH5)

Channel No.	Frequency (MHz)	Measurement Power Output (dBm)	Limit (dBm)	Result
0	2402	5.09	30.00	Pass
39	2441	4.88	30.00	Pass
78	2480	4.59	30.00	Pass

2DH5 2402MHz

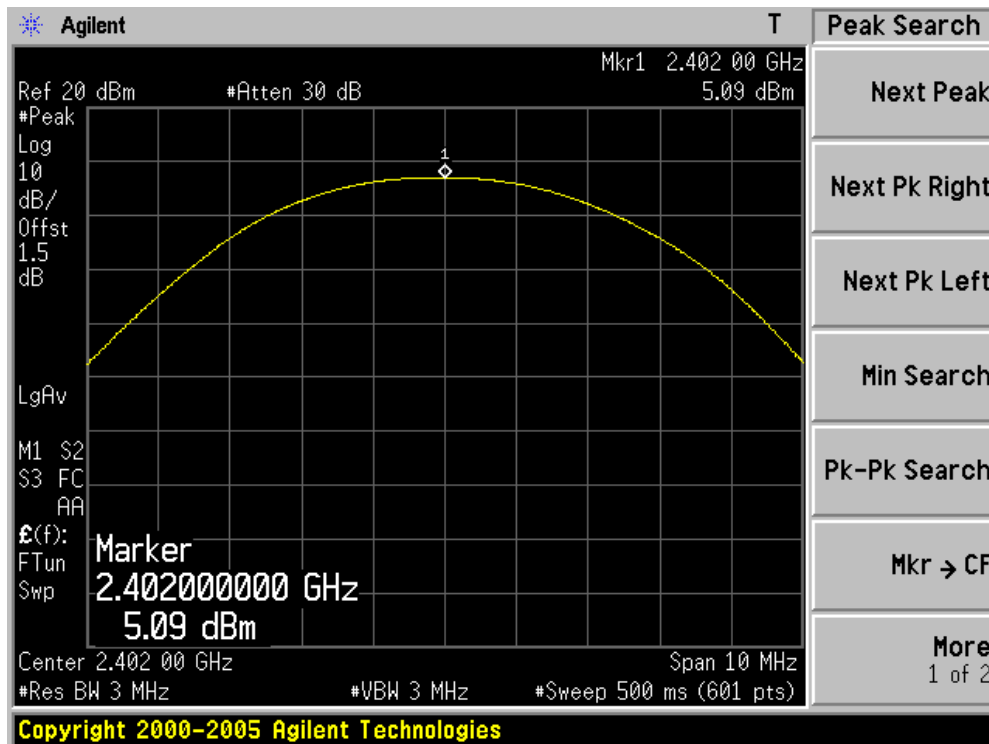

2DH5 2441MHz

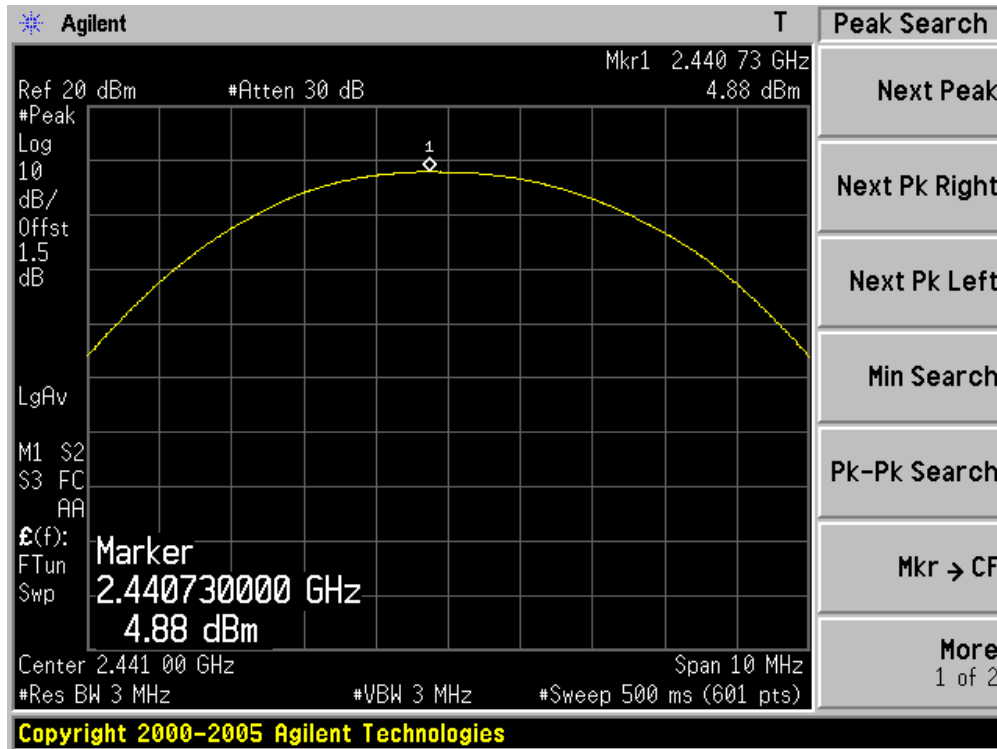

2DH5 2480MHz

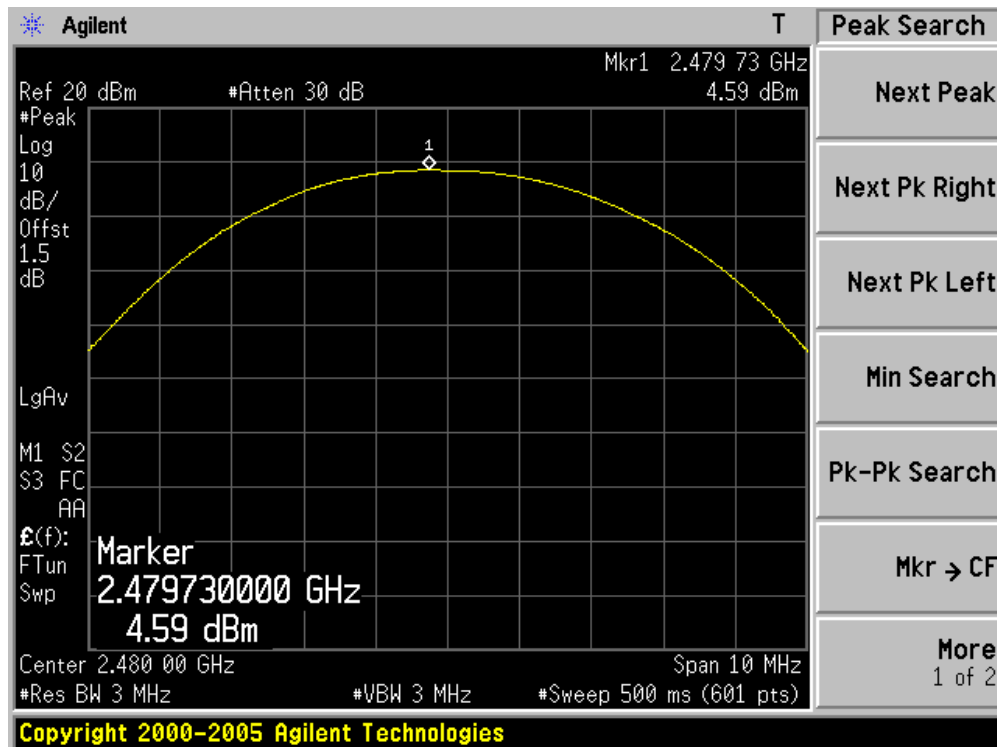

Product	: Zipp
Test Item	: Power Output
Test Mode	: Mode 3: Transmitter-3Mbps (8DPSK_DH5)

Channel No.	Frequency (MHz)	Measurement Power Output (dBm)	Limit (dBm)	Result
0	2402	5.43	30.00	Pass
39	2441	5.07	30.00	Pass
78	2480	5.29	30.00	Pass

3DH5 2402MHz

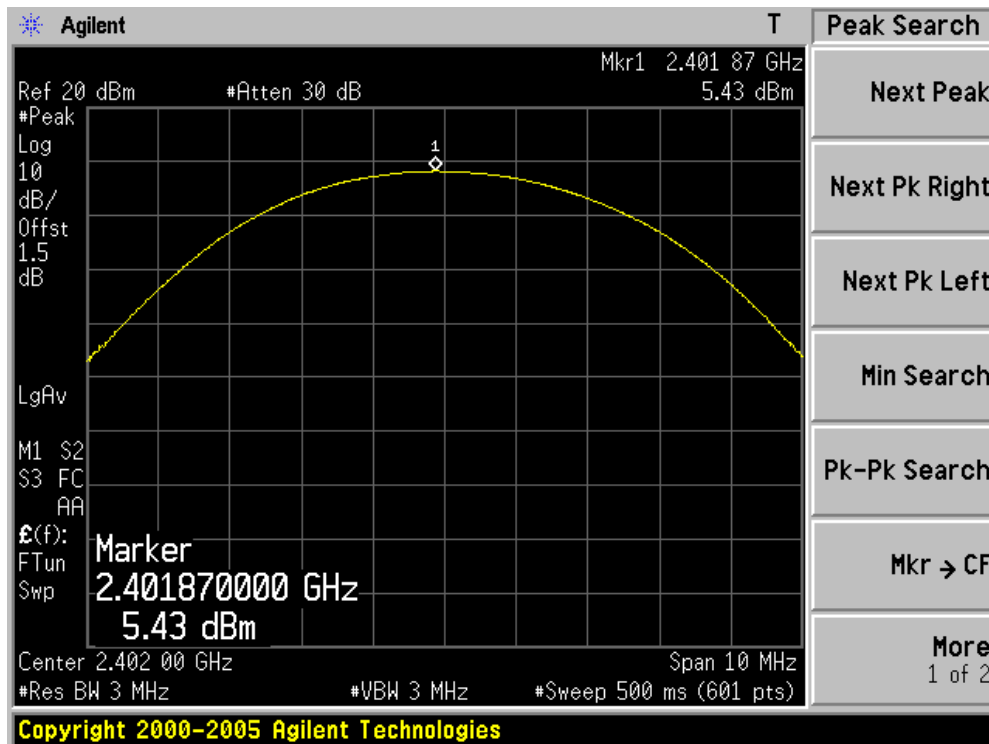

3DH5 2441MHz

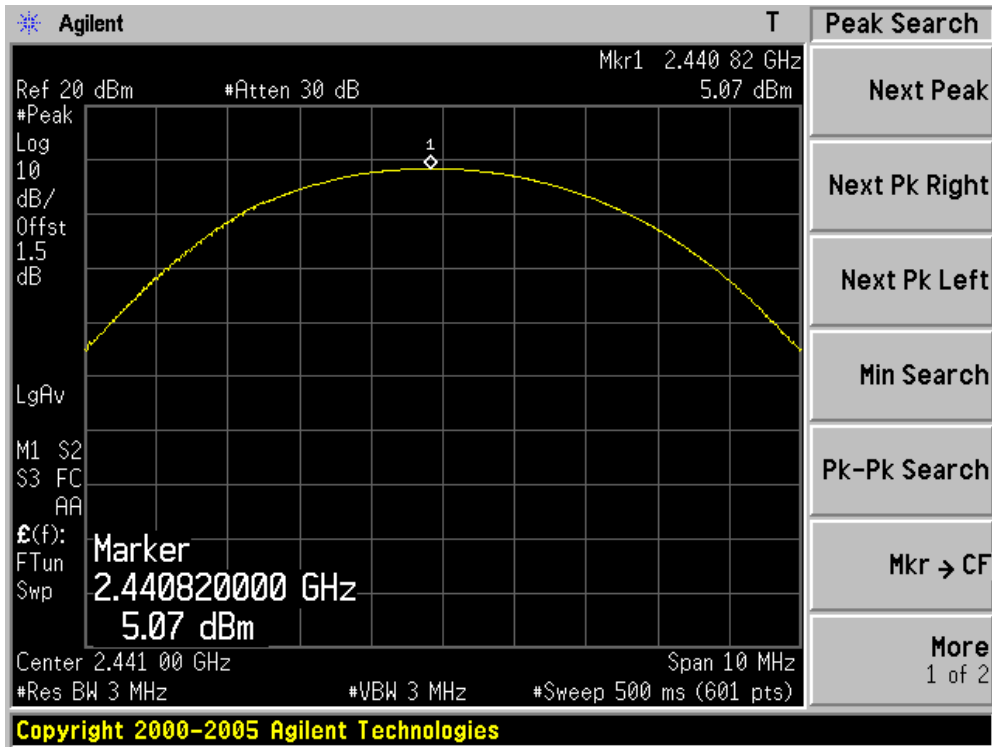

3DH5 2480MHz

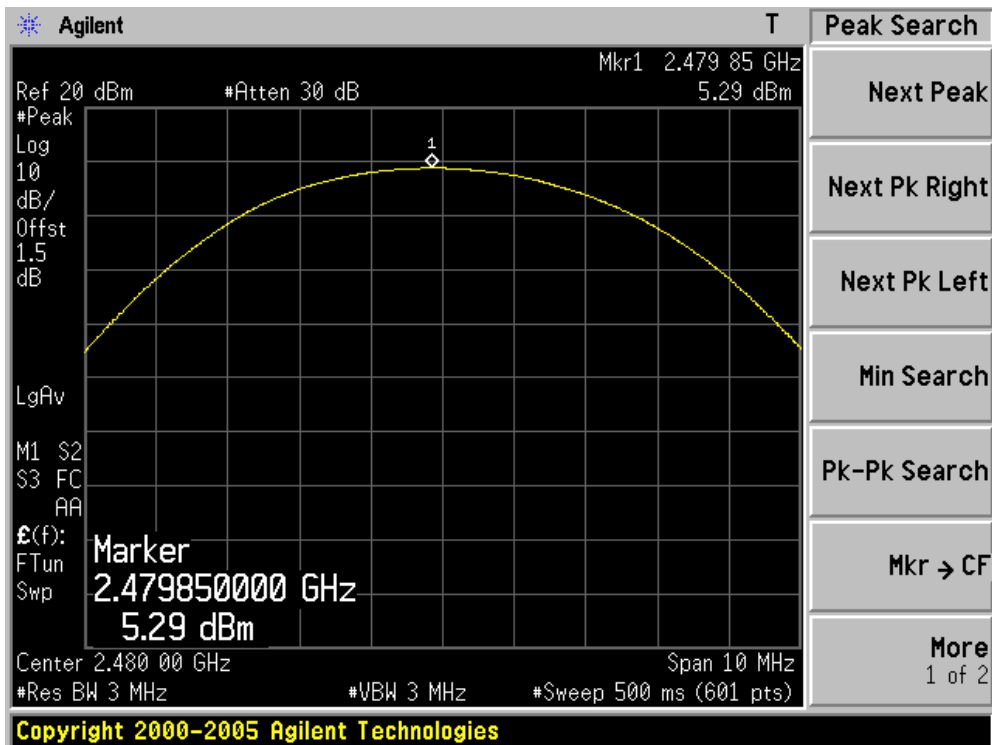

5. Radiated Emission Band Edge

5.1. Test Equipment

Radiated Emission Band Edge / AC-5

Instrument	Manufacturer	Type No.	Serial No.	Cal. Due Date
Spectrum Analyzer	Agilent	N9010A	MY48030494	2016.03.10
Preamplifier	Miteq	NSP1800-25	1364185	2016.05.03
Preamplifier	QuieTek	AP-040G	CHM-0906001	2016.05.03
Bilog Antenna	Teseq GmbH	CBL6112D	27612	2016.10.15
Broad-Band Horn Antenna	Schwarzbeck	BBHA9120D	733	2016.02.26
DRG Horn	ETS-Lindgren	3117	00167055	2016.07.16
Broad-Band Horn Antenna	Schwarzbeck	BBHA9170	294	2016.03.01
Coaxial Cable	Huber+Suhner	SUCOFLEX 106	AC5-C1	2016.03.01
Coaxial Cable	Huber+Suhner	SUCOFLEX 106	AC5-C2	2016.03.01
Coaxial Cable	Huber+Suhner	SUCOFLEX 102	AC5-C3	2016.08.07
Temperature/Humidity Meter	Zhicheng	ZC1-2	AC5-TH	2016.01.07

5.2. Test Setup

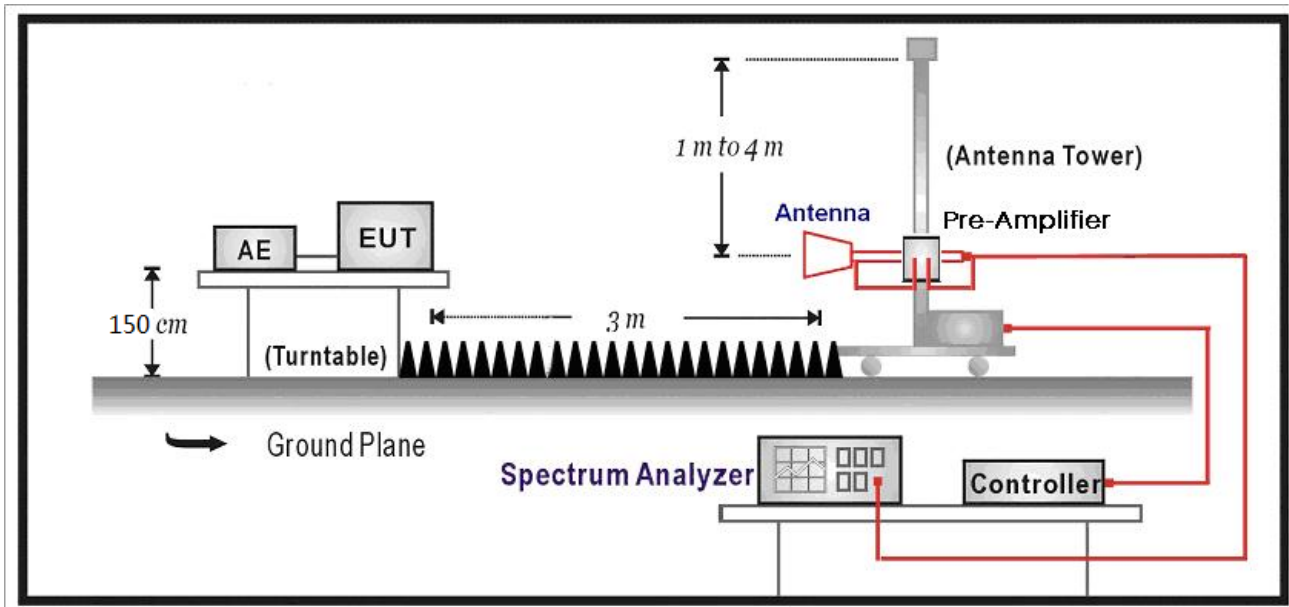

5.3. Limit

Radiated emissions which fall in the restricted bands, as defined in Section 15.205(a) of FCC part 15, must also comply with the radiated emission limits specified in Section 15.209(a) of FCC part 15.

5.4. Test Procedure

According to ANSI C63.10: 2013& ANSI C63.4: 2014

This test is required for any spurious emission or modulation product that falls in a Restricted Band, as defined in Section 15.205 of FCC part 15. It must be performed with the highest gain of each type of antenna proposed for use with the EUT. Use the following spectrum analyzer settings:

Span = wide enough to fully capture the emission being measured

RBW = 1 MHz for $f \geq 1$ GHz, 100 kHz for $f < 1$ GHz

VBW \geq RBW

Sweep = auto

Detector function = peak

Trace = max hold

Follow the guidelines in ANSI C63.4 with respect to maximizing the emission by rotating the EUT, measuring the emission while the EUT is situated in three orthogonal planes (if appropriate), adjusting the measurement antenna height and polarization, etc. A pre-amp and a high pass filter are required for this test, in order to provide the measuring system with sufficient sensitivity. Allow the trace to stabilize. The peak reading of the emission, after being corrected by the antenna factor, cable loss, pre-amp gain, etc., is the peak field strength, which must comply with the limit specified in Section 15.35(b) of FCC part 15.

Now set the VBW to 10 Hz, while maintaining all of the other instrument settings. This peak level, once corrected, must comply with the limit specified in Section 15.209 of FCC Part 15. If the dwell time per channel of the hopping signal is less than 100 ms, then the reading obtained with the 10 Hz VBW may be further adjusted by a “duty cycle correction factor”, derived from $20\log(\text{dwell time}/100 \text{ ms})$, in an effort to demonstrate compliance with the 15.209 limit of FCC part 15.

If the emission on which a radiated measurement must be made is located at the edge of the authorized band of operation, then the alternative “marker-Zipp” method may be employed.

5.5. Uncertainty

The measurement uncertainty above 1G is defined as ± 3.9 dB
 below 1G is defined as ± 3.8 dB

5.6. Test Result

All of the test result shown indicates the worst case, and spectrum analyzer parameters setting as shown below:

Peak detector: RBW = 1MHz, VBW = 3MHz, sweep time = 100ms;

Average = Peak Measure Level+ Duty Factor

Duty Factor= $20 \cdot \text{LOG}(\text{Pulse Number} \cdot \text{On Time}/100) = -30.82\text{dB}$ in worst condition in normal use.

Pulse Number



Engineer: Scott	
Site: AC5	Time: 2015/12/12 - 14:08
Limit: FCC_Part15.209_RE(3m)	Margin: 0
Probe: Horn_3117_00167055(1-18GHz)	Polarity: Horizontal
EUT: Zipp	Power: AC 120V/60Hz
Note: Mode 1:Transmit at 2402Mhz by DH5	

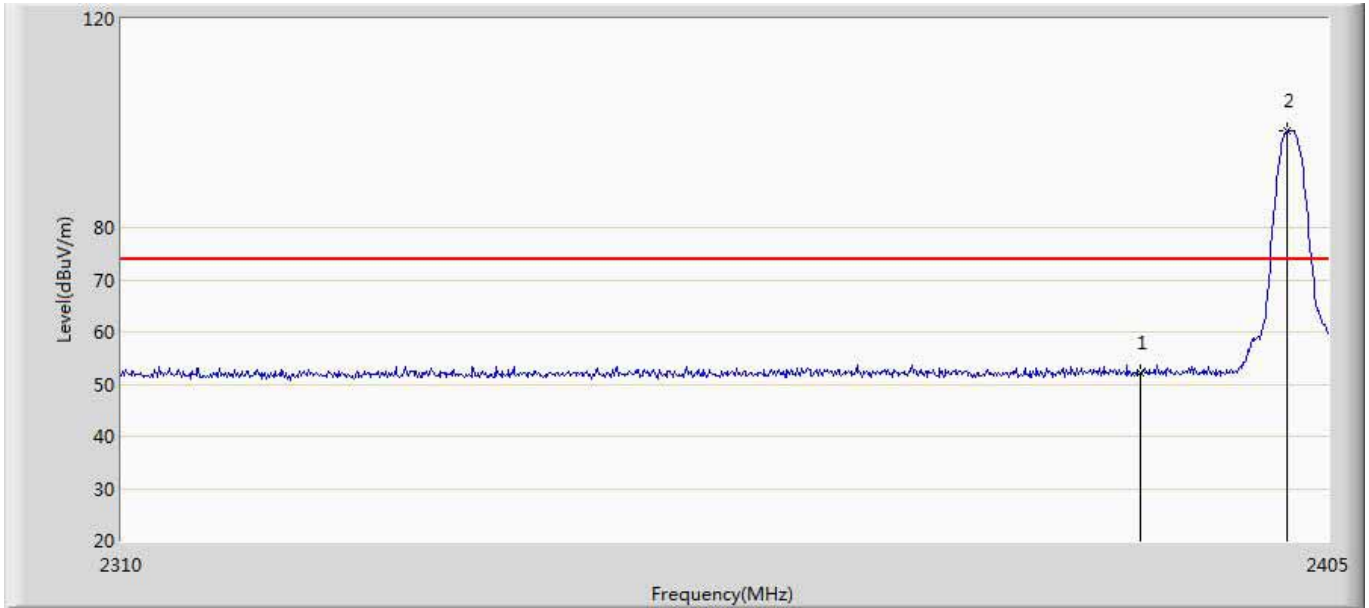

No	Mark	Frequency (MHz)	Measure Level (dBuV/m)	Reading Level (dBuV)	Over Limit (dB)	Limit (dBuV/m)	Factor (dB)	Type
1		2390.000	52.206	14.851	-21.794	74.000	37.355	PK
2	*	2401.770	98.484	61.142	N/A	N/A	37.342	PK

No	Mark	Frequency (MHz)	Peak Level (dBuV/m)	AV Level (dBuV)	Over Limit (dB)	Limit (dBuV/m)	Duty Factor (dB)	Type
1		2390.000	52.206	21.386	-32.614	54.000	-30.82	AV
2		2401.770	98.484	67.664	N/A	N/A	-30.82	AV

Engineer: Scott	
Site: AC5	Time: 2015/12/12 - 14:12
Limit: FCC_Part15.209_RE(3m)	Margin: 0
Probe: Horn_3117_00167055(1-18GHz)	Polarity: Vertical
EUT: Zipp	Power: AC 120V/60Hz
Note: Mode 1:Transmit at 2402Mhz by DH5	

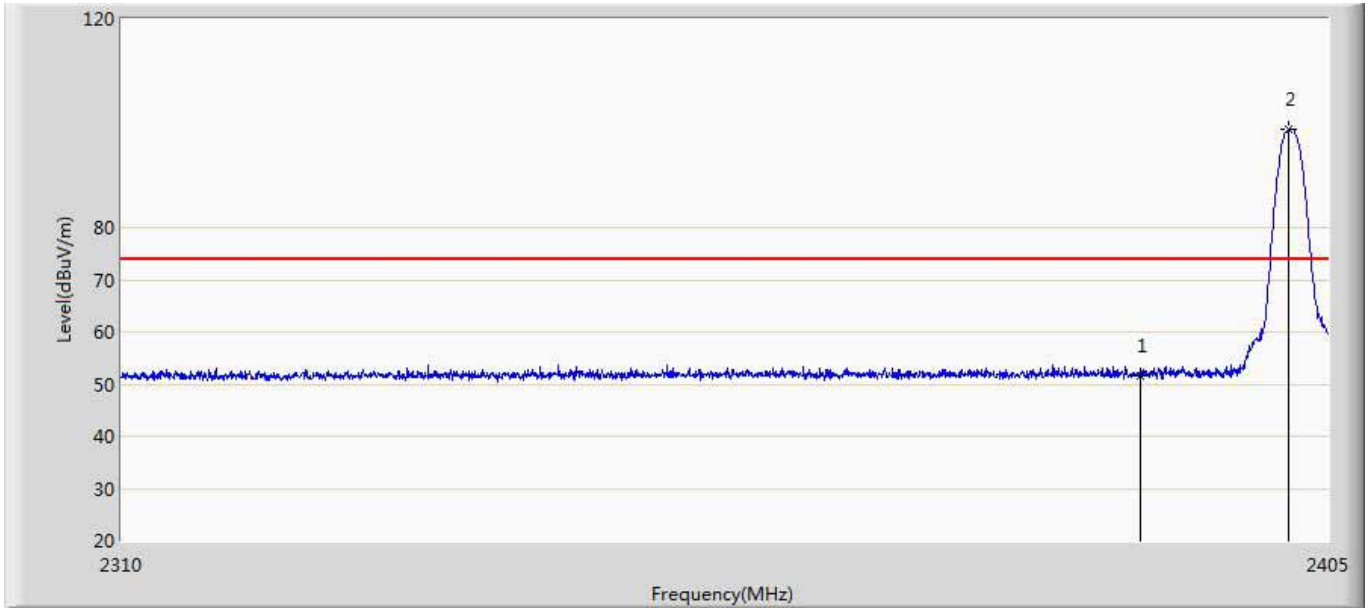

No	Mark	Frequency (MHz)	Measure Level (dBuV/m)	Reading Level (dBuV)	Over Limit (dB)	Limit (dBuV/m)	Factor (dB)	Type
1		2390.000	51.518	14.163	-22.482	74.000	37.355	PK
2	*	2401.865	98.745	61.403	N/A	N/A	37.342	PK

No	Mark	Frequency (MHz)	Peak Level (dBuV/m)	AV Level (dBuV)	Over Limit (dB)	Limit (dBuV/m)	Duty Factor (dB)	Type
1		2390.000	51.518	20.698	-33.302	54.000	-30.82	AV
2		2401.865	98.745	67.925	N/A	N/A	-30.82	AV

Engineer: Scott	
Site: AC5	Time: 2015/12/12 - 14:16
Limit: FCC_Part15.209_RE(3m)	Margin: 0
Probe: Horn_3117_00167055(1-18GHz)	Polarity: Horizontal
EUT: Zipp	Power: AC 120V/60Hz
Note: Mode 1:Transmit at 2480Mhz by DH5	

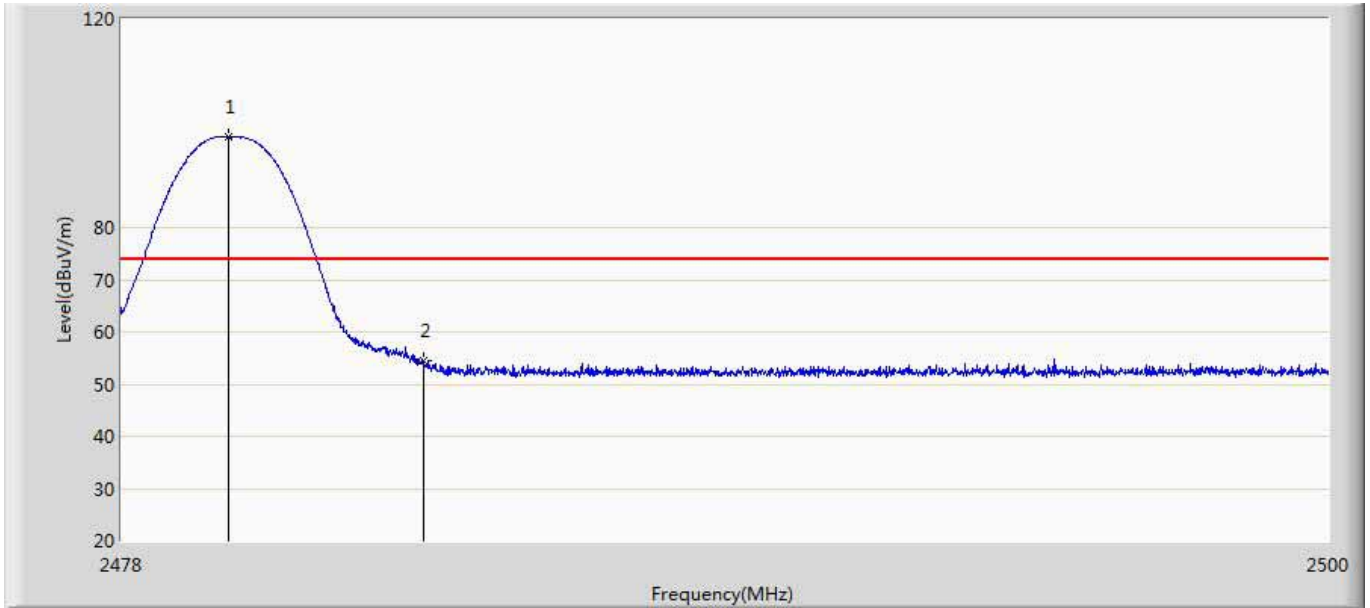

No	Mark	Frequency (MHz)	Measure Level (dBuV/m)	Reading Level (dBuV)	Over Limit (dB)	Limit (dBuV/m)	Factor (dB)	Type
1	*	2479.947	97.381	59.895	N/A	N/A	37.486	PK
2		2483.500	54.510	16.999	-19.490	74.000	37.511	PK

No	Mark	Frequency (MHz)	Peak Level (dBuV/m)	AV Level (dBuV)	Over Limit (dB)	Limit (dBuV/m)	Duty Factor (dB)	Type
1	*	2479.947	97.381	66.561	N/A	N/A	-30.82	AV
2		2483.500	54.510	23.690	-30.310	54.000	-30.82	AV

Engineer: Scott	
Site: AC5	Time: 2015/12/12 - 14:22
Limit: FCC_Part15.209_RE(3m)	Margin: 0
Probe: Horn_3117_00167055(1-18GHz)	Polarity: Vertical
EUT: Zipp	Power: AC 120V/60Hz
Note: Mode 1:Transmit at 2480Mhz by DH5	

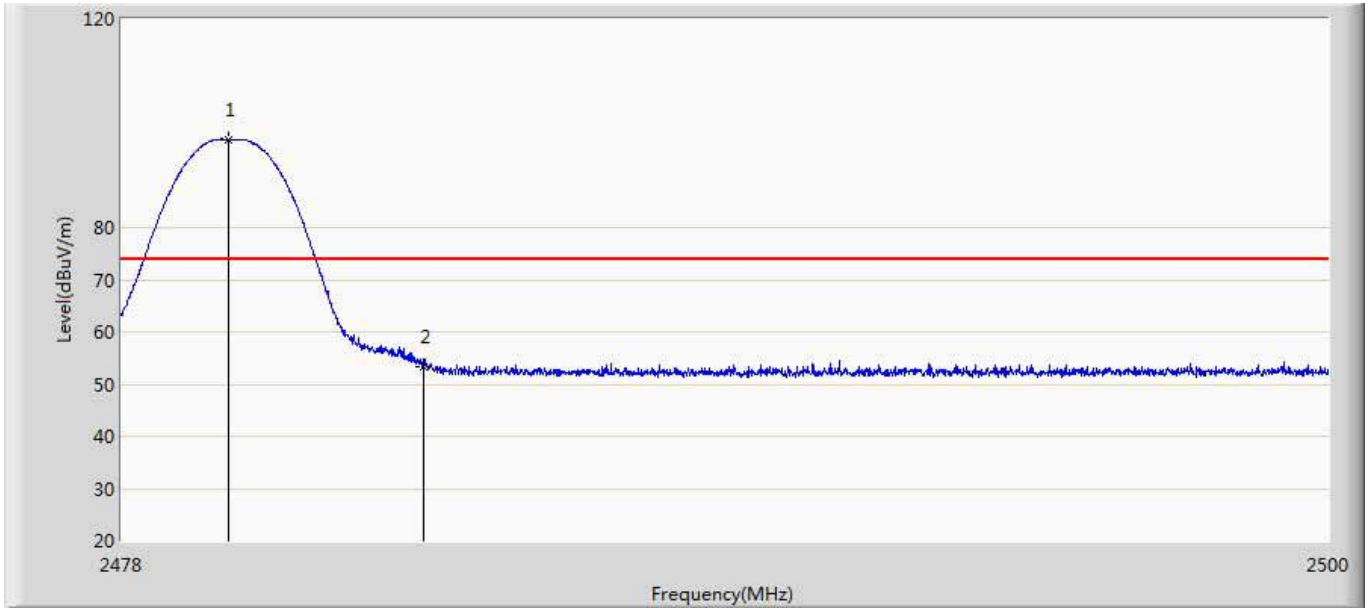

No	Mark	Frequency (MHz)	Measure Level (dBuV/m)	Reading Level (dBuV)	Over Limit (dB)	Limit (dBuV/m)	Factor (dB)	Type
1	*	2479.947	96.897	59.411	N/A	N/A	37.486	PK
2		2483.500	53.254	15.743	-20.746	74.000	37.511	PK

No	Mark	Frequency (MHz)	Peak Level (dBuV/m)	AV Level (dBuV)	Over Limit (dB)	Limit (dBuV/m)	Duty Factor (dB)	Type
1	*	2479.947	96.897	66.077	N/A	N/A	-30.82	AV
2		2483.500	53.254	22.434	-31.566	54.000	-30.82	AV

Engineer: Scott	
Site: AC5	Time: 2015/12/12 - 14:27
Limit: FCC_Part15.209_RE(3m)	Margin: 0
Probe: Horn_3117_00167055(1-18GHz)	Polarity: Horizontal
EUT: Zipp	Power: AC 120V/60Hz
Note: Mode 1:Transmit at 2402Mhz by 2DH5	

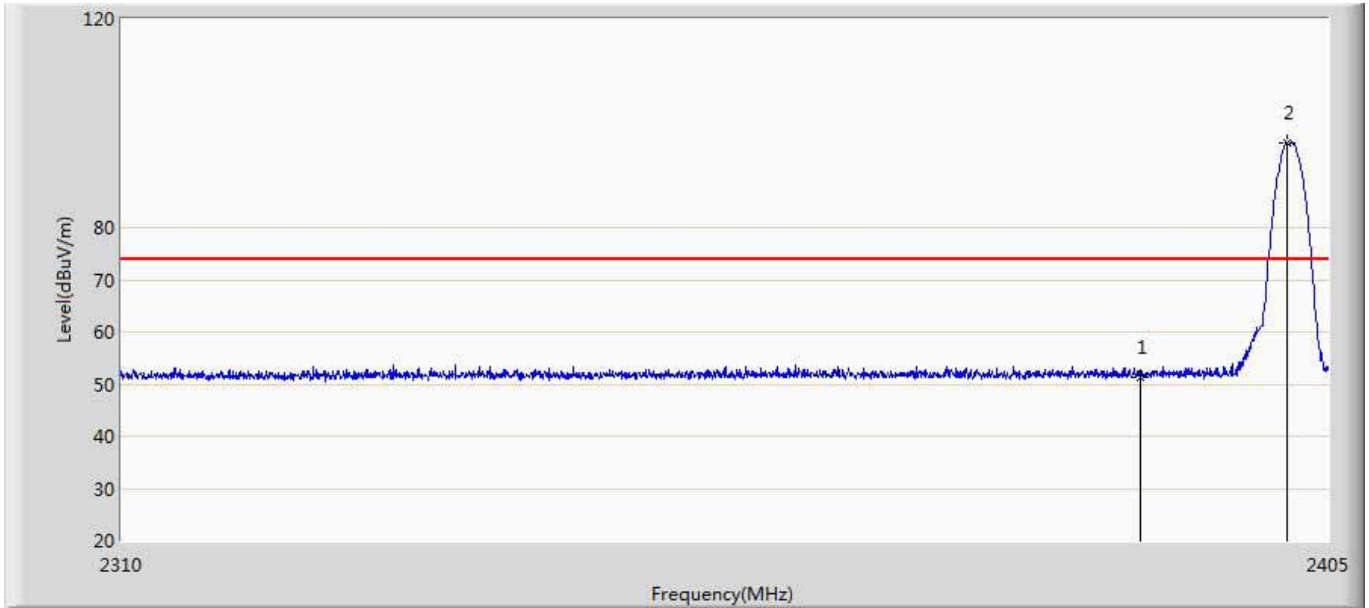

No	Mark	Frequency (MHz)	Measure Level (dBuV/m)	Reading Level (dBuV)	Over Limit (dB)	Limit (dBuV/m)	Factor (dB)	Type
1		2390.000	51.386	14.031	-22.614	74.000	37.355	PK
2	*	2401.722	96.269	58.927	N/A	N/A	37.342	PK

No	Mark	Frequency (MHz)	Peak Level (dBuV/m)	AV Level (dBuV)	Over Limit (dB)	Limit (dBuV/m)	Duty Factor (dB)	Type
1		2390.000	51.386	20.566	-33.434	54.000	-30.82	AV
2		2401.722	96.269	65.449	N/A	N/A	-30.82	AV

Engineer: Scott	
Site: AC5	Time: 2015/12/12 - 14:33
Limit: FCC_Part15.209_RE(3m)	Margin: 0
Probe: Horn_3117_00167055(1-18GHz)	Polarity: Vertical
EUT: Zipp	Power: AC 120V/60Hz
Note: Mode 1:Transmit at 2402Mhz by 2DH5	

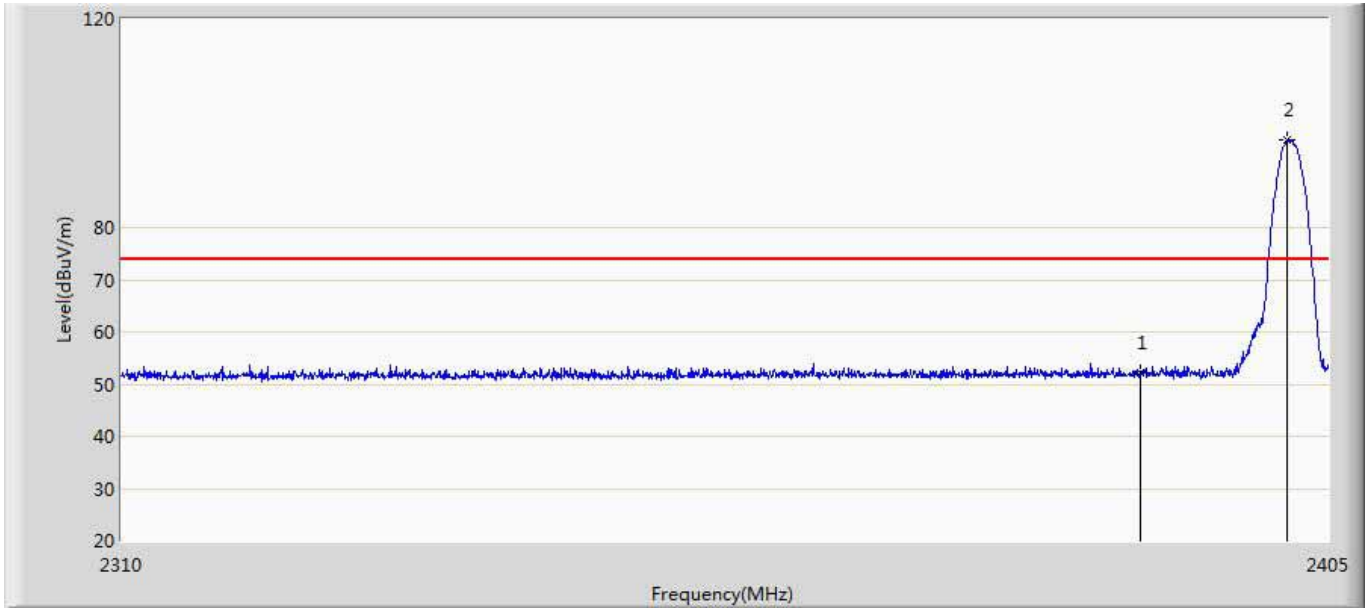

No	Mark	Frequency (MHz)	Measure Level (dBuV/m)	Reading Level (dBuV)	Over Limit (dB)	Limit (dBuV/m)	Factor (dB)	Type
1		2390.000	52.318	14.963	-21.682	74.000	37.355	PK
2	*	2401.770	96.907	59.565	N/A	N/A	37.342	PK

No	Mark	Frequency (MHz)	Peak Level (dBuV/m)	AV Level (dBuV)	Over Limit (dB)	Limit (dBuV/m)	Duty Factor (dB)	Type
1		2390.000	52.318	21.498	-32.502	54.000	-30.82	AV
2		2401.770	96.907	66.087	N/A	N/A	-30.82	AV

Engineer: Scott	
Site: AC5	Time: 2015/12/12 - 14:37
Limit: FCC_Part15.209_RE(3m)	Margin: 0
Probe: Horn_3117_00167055(1-18GHz)	Polarity: Horizontal
EUT: Zipp	Power: AC 120V/60Hz
Note: Mode 1:Transmit at 2480Mhz by 2DH5	

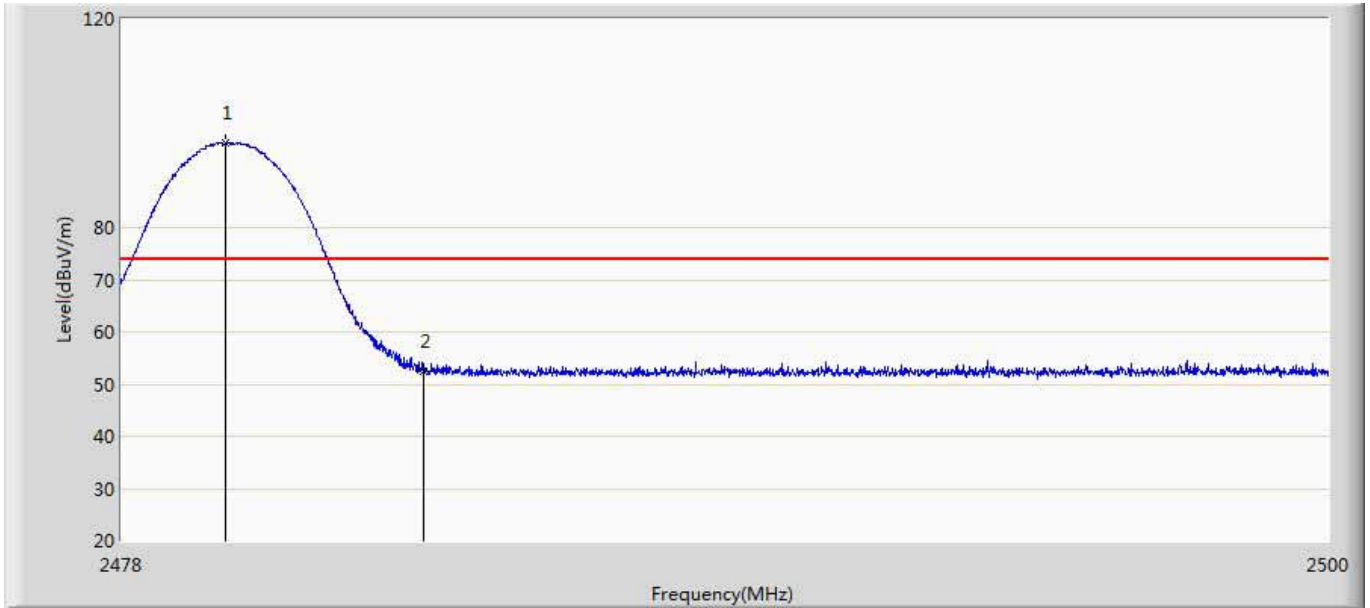

No	Mark	Frequency (MHz)	Measure Level (dBuV/m)	Reading Level (dBuV)	Over Limit (dB)	Limit (dBuV/m)	Factor (dB)	Type
1	*	2479.881	96.257	58.772	N/A	N/A	37.485	PK
2		2483.500	52.517	15.006	-21.483	74.000	37.511	PK

No	Mark	Frequency (MHz)	Peak Level (dBuV/m)	AV Level (dBuV)	Over Limit (dB)	Limit (dBuV/m)	Duty Factor (dB)	Type
1	*	2479.881	96.257	65.437	N/A	N/A	-30.82	AV
2		2483.500	52.517	21.697	-32.303	54.000	-30.82	AV

Engineer: Scott	
Site: AC5	Time: 2015/12/12 - 14:42
Limit: FCC_Part15.209_RE(3m)	Margin: 0
Probe: Horn_3117_00167055(1-18GHz)	Polarity: Vertical
EUT: Zipp	Power: AC 120V/60Hz
Note: Mode 1:Transmit at 2480Mhz by 2DH5	

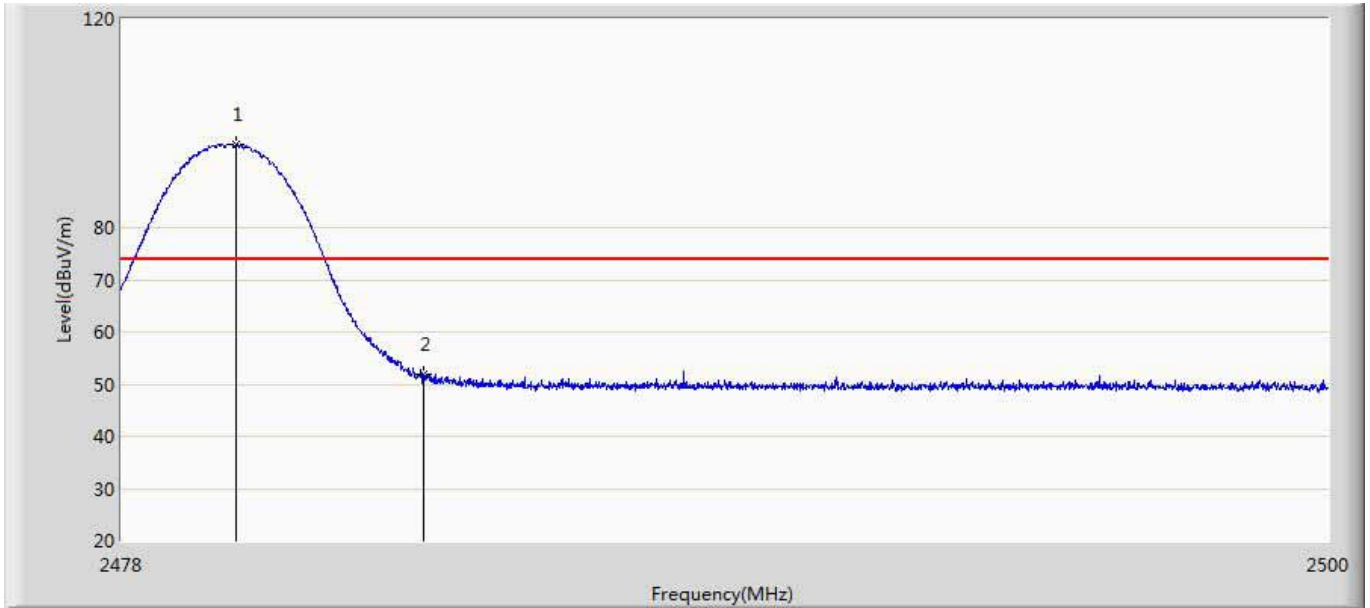

No	Mark	Frequency (MHz)	Measure Level (dBuV/m)	Reading Level (dBuV)	Over Limit (dB)	Limit (dBuV/m)	Factor (dB)	Type
1	*	2480.079	95.935	58.448	N/A	N/A	37.486	PK
2		2483.500	51.752	14.241	-22.248	74.000	37.511	PK

No	Mark	Frequency (MHz)	Peak Level (dBuV/m)	AV Level (dBuV)	Over Limit (dB)	Limit (dBuV/m)	Duty Factor (dB)	Type
1	*	2480.079	95.935	65.115	N/A	N/A	-30.82	AV
2		2483.500	51.752	20.932	-33.068	54.000	-30.82	AV

Engineer: Scott	
Site: AC5	Time: 2015/12/12 - 14:47
Limit: FCC_Part15.209_RE(3m)	Margin: 0
Probe: Horn_3117_00167055(1-18GHz)	Polarity: Horizontal
EUT: Zipp	Power: AC 120V/60Hz
Note: Mode 1:Transmit at 2402Mhz by 3DH5	

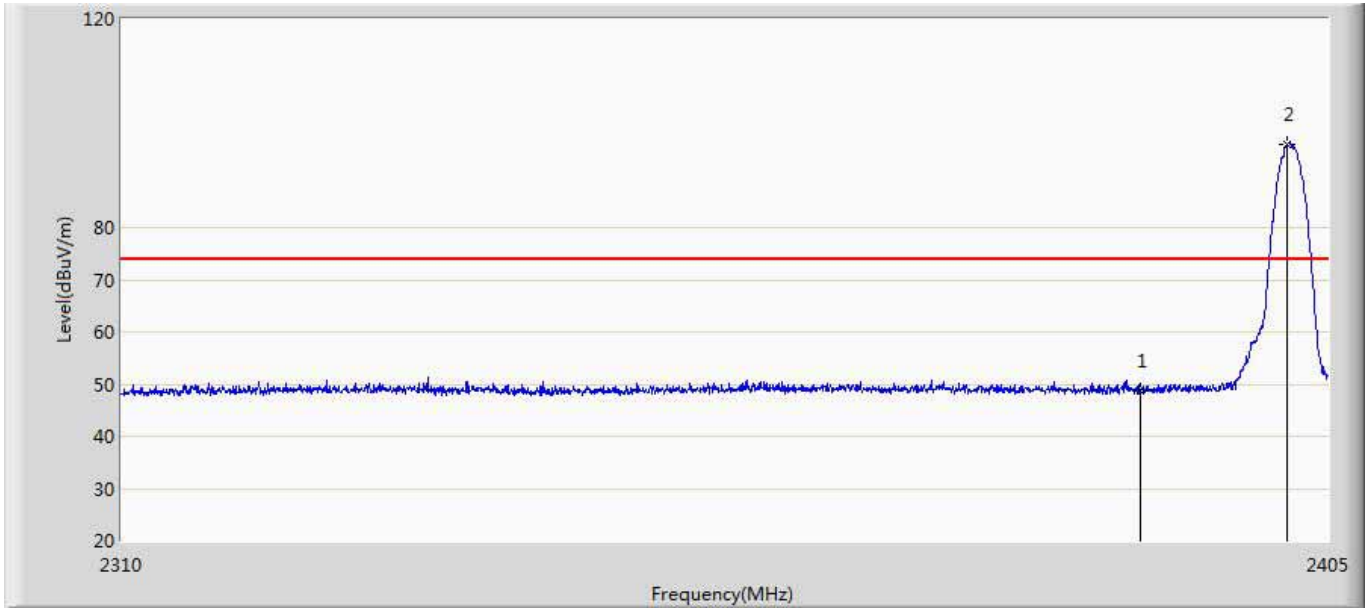

No	Mark	Frequency (MHz)	Measure Level (dBuV/m)	Reading Level (dBuV)	Over Limit (dB)	Limit (dBuV/m)	Factor (dB)	Type
1		2390.000	48.782	11.427	-25.218	74.000	37.355	PK
2	*	2401.722	95.979	58.637	N/A	N/A	37.342	PK

No	Mark	Frequency (MHz)	Peak Level (dBuV/m)	AV Level (dBuV)	Over Limit (dB)	Limit (dBuV/m)	Duty Factor (dB)	Type
1		2390.000	48.782	17.962	-36.038	54.000	-30.82	AV
2		2401.722	95.979	65.159	N/A	N/A	-30.82	AV

Engineer: Scott	
Site: AC5	Time: 2015/12/12 - 14:51
Limit: FCC_Part15.209_RE(3m)	Margin: 0
Probe: Horn_3117_00167055(1-18GHz)	Polarity: Vertical
EUT: Zipp	Power: AC 120V/60Hz
Note: Mode 1:Transmit at 2402Mhz by 3DH5	

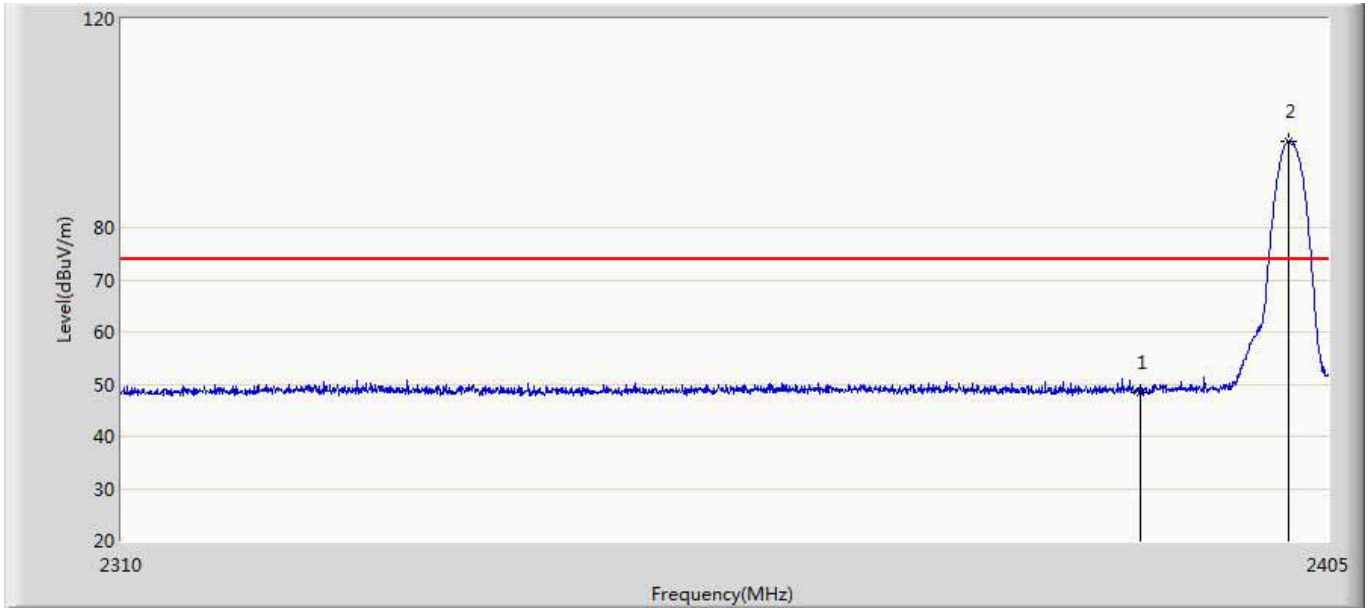

No	Mark	Frequency (MHz)	Measure Level (dBuV/m)	Reading Level (dBuV)	Over Limit (dB)	Limit (dBuV/m)	Factor (dB)	Type
1		2390.000	48.450	11.095	-25.550	74.000	37.355	PK
2	*	2401.865	96.575	59.233	N/A	N/A	37.342	PK

No	Mark	Frequency (MHz)	Peak Level (dBuV/m)	AV Level (dBuV)	Over Limit (dB)	Limit (dBuV/m)	Duty Factor (dB)	Type
1		2390.000	48.450	17.63	-36.370	54.000	-30.82	AV
2		2401.865	96.575	65.755	-30.270	54.000	-30.82	AV

Engineer: Scott	
Site: AC5	Time: 2015/12/12 - 14:55
Limit: FCC_Part15.209_RE(3m)	Margin: 0
Probe: Horn_3117_00167055(1-18GHz)	Polarity: Horizontal
EUT: Zipp	Power: AC 120V/60Hz
Note: Mode 1:Transmit at 2480Mhz by 3DH5	

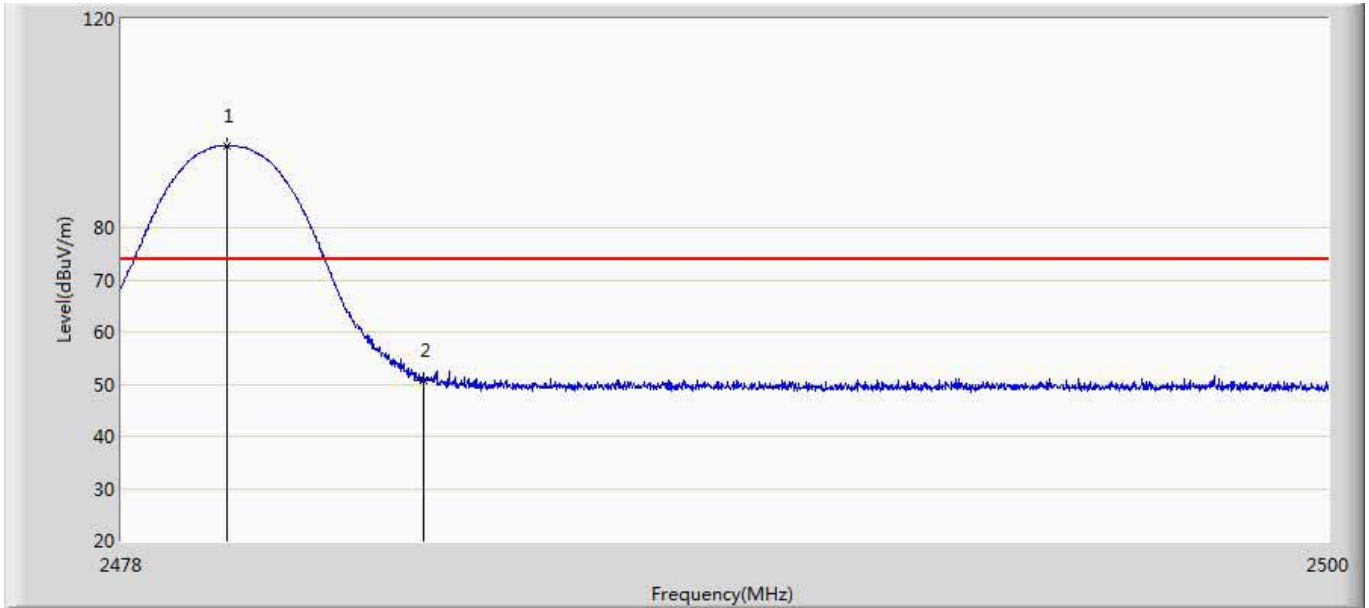

No	Mark	Frequency (MHz)	Measure Level (dBuV/m)	Reading Level (dBuV)	Over Limit (dB)	Limit (dBuV/m)	Factor (dB)	Type
1	*	2479.914	95.657	58.172	N/A	N/A	37.485	PK
2		2483.500	50.582	13.071	-23.418	74.000	37.511	PK

No	Mark	Frequency (MHz)	Peak Level (dBuV/m)	AV Level (dBuV)	Over Limit (dB)	Limit (dBuV/m)	Duty Factor (dB)	Type
1	*	2479.914	95.657	64.837	N/A	N/A	-30.82	AV
2		2483.500	50.582	19.762	-34.238	54.000	-30.82	AV

Engineer: Scott	
Site: AC5	Time: 2015/12/12 - 14:59
Limit: FCC_Part15.209_RE(3m)	Margin: 0
Probe: Horn_3117_00167055(1-18GHz)	Polarity: Vertical
EUT: Zipp	Power: AC 120V/60Hz
Note: Mode 1:Transmit at 2480Mhz by 3DH5	

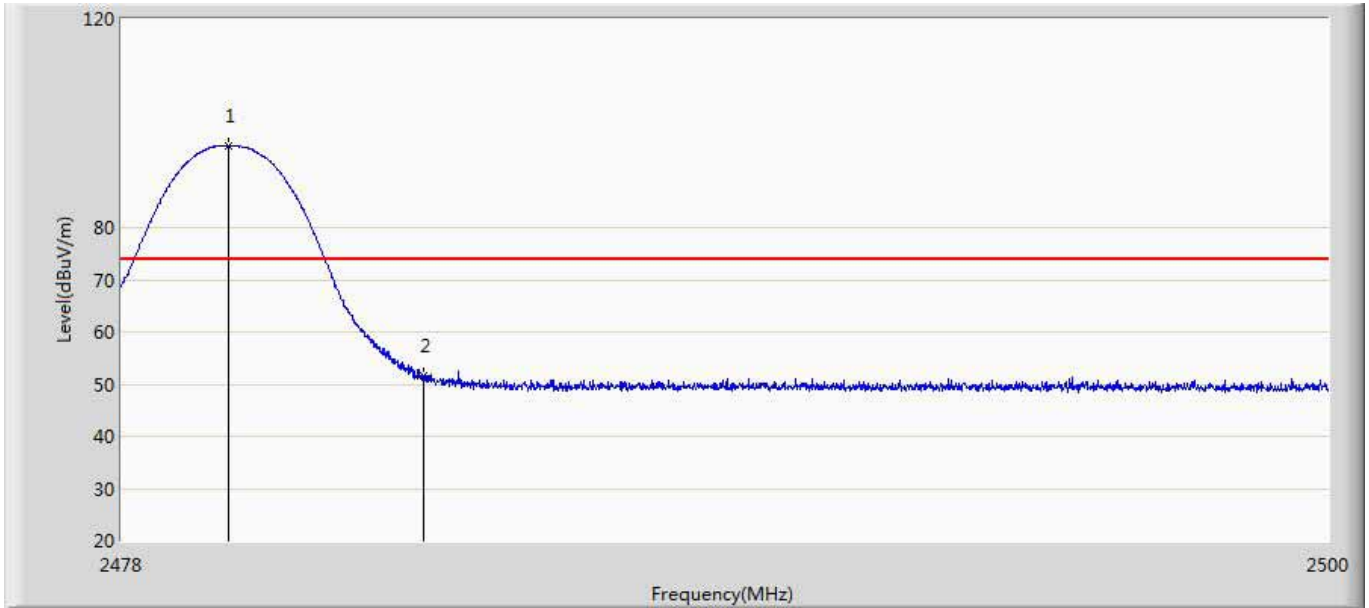

No	Mark	Frequency (MHz)	Measure Level (dBuV/m)	Reading Level (dBuV)	Over Limit (dB)	Limit (dBuV/m)	Factor (dB)	Type
1	*	2479.947	95.769	58.283	N/A	N/A	37.486	PK
2		2483.500	51.585	14.074	-22.415	74.000	37.511	PK

No	Mark	Frequency (MHz)	Peak Level (dBuV/m)	AV Level (dBuV)	Over Limit (dB)	Limit (dBuV/m)	Duty Factor (dB)	Type
1	*	2479.947	95.769	64.949	N/A	N/A	-30.82	AV
2		2483.500	51.585	20.765	-33.235	54.000	-30.82	AV

————— The End —————