

Test Report

FCC Part15 Subpart C

Product Name : Zipp
Model No. : LTH300
FCC ID : Y2SLTH300
IC ID : 9452A-LTH300

Applicant : LIBRATONE A/S

Address : Marielundvej 43A, DK-2730 Herlev, Denmark

Date of Receipt : Jun. 25, 2015
Test Date : Jun. 25, 2015~ Aug. 14, 2015
Issued Date : Sept. 21, 2015
Report No. : 1560645R-RF-US-P06V01
Report Version : V 1.4

The test results relate only to the samples tested.

The test results shown in the test report are traceable to the national/international standard through the calibration of the equipment and evaluated measurement uncertainty herein.

This report must not be used to claim product endorsement by any agency of the government.

The test report shall not be reproduced without the written approval of QuieTek Corporation.

Test Report Certification

Issued Date : Sept. 21, 2015

Report No. : 1560645R-RF-US-P06V01



Product Name : Zipp
Applicant : LIBRATONE A/S
Address : Marielundvej 43A, DK-2730 Herlev, Denmark
Manufacturer : Goertek Inc
Address : No 268 Dongfang Rd., New&high-tech Industry Development
Zone Weifang Shandong Province 261031, PRC.
Model No. : LTH300
EUT Voltage : AC 100~240V, 50/60Hz, 1.0A
Brand Name : LIBRATONE
FCC ID : Y2SLTH300
IC ID : 9452A-LTH300
Applicable Standard : FCC CFR Title 47 Part 15 Subpart C: 2015
ANSI C63.4: 2014; ANSI C63.10: 2013
Industry Canada RSS-Gen Issue 4/RSS-247 Issue 1
Test Result : Complied
Performed Location : Suzhou EMC Laboratory
No.99 Hongye Rd., Suzhou Industrial Park, Suzhou,215006,
Jiangsu, China
TEL: +86-512-6251-5088 / FAX: +86-512-6251-5098
FCC Registration Number: 800392; IC Lab Code: 4075B

Documented By

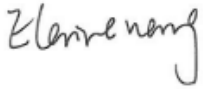
: 
Elaine Wang Senior Engineer

Reviewed By

: 
Harry Zhao RF Engineering Manager

Approved By

: 
Dream Cao Director

Laboratory Information

We, **Quietek Corporation**, are an independent EMC and safety consultancy that was established the whole facility in our laboratories. The test facility has been accredited/accepted(audited or listed) by the following related bodies in compliance with ISO 17025, EN 45001 and specified testing scope:

Taiwan R.O.C.	:	BSMI, NCC,TAF
USA	:	FCC
Japan	:	VCCI
China	:	CNAS

The related certificate for our laboratories about the test site and management system can be downloaded from Quietek Corporation's Web Site :<http://www.quietek.com/tw/ctg/cts/accreditations.htm>

The address and introduction of Quietek Corporation's laboratories can be founded in our Web site :
<http://www.quietek.com/>

If you have any comments, Please don't hesitate to contact us. Our contact information is as below:

HsinChu Testing Laboratory :

No.75-2, 3rd Lin, Wangye Keng, Yonghxing Tsuen, Qionglin Shiang, Hsinchu County 307, Taiwan, R.O.C.
TEL:+886-3-592-8858 / FAX:+886-3-592-8859 E-Mail : service@quietek.com

LinKou Testing Laboratory :

No.5-22, Ruishukeng, Linkou Dist., New Taipei City 24451, Taiwan, R.O.C.
TEL : 886-2-8601-3788 / FAX : 886-2-8601-3789 E-Mail : service@quietek.com

Suzhou Testing Laboratory :

No.99 Hongye Rd., Suzhou Industrial Park, Suzhou, 215006, Jiangsu, China
TEL : +86-512-6251-5088 / FAX : 86-512-6251-5098 E-Mail : service@quietek.com

TABLE OF CONTENTS

Description	Page
1. General Information	8
1.1. EUT Description	8
1.1. Mode of Operation	11
1.2. Tested System Details.....	12
1.3. Configuration of Tested System	13
1.4. EUT Exercise Software	14
2. Technical Test.....	15
2.1. Summary of Test Result	15
2.2. Test Environment	17
3. Conducted Emission	18
3.1. Test Equipment	18
3.2. Test Setup	18
3.3. Limit.....	19
3.4. Test Procedure	19
3.5. Uncertainty	19
3.6. Test Result	20
4. Radiated Emission	22
4.1. Test Equipment	22
4.2. Test Setup	23
4.3. Limit.....	24
4.4. Test Procedure	24
4.5. Uncertainty	25
4.6. Test Result	26
5. 20dB Bandwidth	31
5.1. Test Equipment	31
5.2. Test Setup	31
5.3. Limit.....	31
5.4. Test Procedure	32
5.5. Uncertainty	32
5.6. Test Result	33
6. Carrier Frequency Separation.....	39
6.1. Test Equipment	39
6.2. Test Setup	39
6.3. Limit.....	39
6.4. Test Procedure	40
6.5. Uncertainty	40
6.6. Test Result	41

7.	Number of Hopping Frequencies	47
7.1.	Test Equipment	47
7.2.	Test Setup	47
7.3.	Limit.....	47
7.4.	Test Procedure	48
7.5.	Uncertainty	48
7.6.	Test Result	49
8.	Time of Occupancy (Dwell Time)	58
8.1.	Test Equipment	58
8.2.	Test Setup	58
8.3.	Limit.....	58
8.4.	Test Procedure	59
8.5.	Uncertainty	59
8.6.	Test Result	60
9.	Peak Output Power	66
9.1.	Test Equipment	66
9.2.	Test Setup	66
9.3.	Limit.....	66
9.4.	Test Procedure	67
9.5.	Uncertainty	67
9.6.	Test Result	68
10.	Band-edge Compliance of RF Conducted Emissions	74
10.1.	Test Equipment	74
10.2.	Test Setup	74
10.3.	Limit.....	74
10.4.	Test Procedure	75
10.5.	Uncertainty	75
10.6.	Test Result	76
11.	Spurious RF Conducted Emissions.....	80
11.1.	Test Equipment	80
11.2.	Test Setup	80
11.3.	Limit.....	80
11.4.	Test Procedure	81
11.5.	Uncertainty	81
11.6.	Test Result	82
12.	Radiated Emission Band Edge	88
12.1.	Test Equipment	88
12.2.	Test Setup	89

12.3. Limit.....89
12.4. Test Procedure89
12.5. Uncertainty90
12.6. Test Result91

History of This Test Report

REPORT NO.	VERSION	DESCRIPTION	ISSUED DATE
1560645R-RF-US-P06V01	V1.0	Initial Issued Report	Aug. 17, 2015
1560645R-RF-US-P06V01	V1.1	Changed EUT voltage	Aug. 21, 2015
1560645R-RF-US-P06V01	V1.2	Add frequency of power	Aug. 31, 2015
1560645R-RF-US-P06V01	V1.3	Modified conducted data	Sept. 10, 2015
1560645R-RF-US-P06V01	V1.4	Modified some data	Sept. 21, 2015

1. General Information

1.1. EUT Description

Product Name	Zipp
Brand Name	LIBRATONE
Model No.	LTH300
Working Voltage	AC 100~240V, 50/60Hz, 1.0A
Bluetooth Specification	3.0 + Version 4.0
Frequency Range	2402- 2480 MHz
Channel Number	V3.0+HS: 79 V4.0: 40
Channel Separation	V3.0+HS: 1MHz V4.0: 2MHz
Type of Modulation	V3.0: GFSK, Pi/4 DQPSK, 8DPSK V4.0: GFSK
Data Rate	V3.0: 1Mbps(GFSK), 2Mbps(Pi/4 DQPSK), 3Mbps (8DPSK) V4.0: 1Mbps
Antenna Type	Reference to Antenna List
Peak Antenna Gain	Reference to Antenna List

Bluetooth Working Frequency of Each Channel: (For V3.0)							
Channel	Frequency	Channel	Frequency	Channel	Frequency	Channel	Frequency
00	2402 MHz	01	2403 MHz	02	2404 MHz	03	2405 MHz
04	2406 MHz	05	2407 MHz	06	2408 MHz	07	2409 MHz
08	2410 MHz	09	2411 MHz	10	2412 MHz	11	2413 MHz
12	2414 MHz	13	2415 MHz	14	2416 MHz	15	2417 MHz
16	2418 MHz	17	2419 MHz	18	2420 MHz	19	2421 MHz
20	2422 MHz	21	2423 MHz	22	2424 MHz	23	2425 MHz
24	2426 MHz	25	2427 MHz	26	2428 MHz	27	2429 MHz
28	2430 MHz	29	2431 MHz	30	2432 MHz	31	2433 MHz
32	2434 MHz	33	2435 MHz	34	2436 MHz	35	2437 MHz
36	2438 MHz	37	2439 MHz	38	2440 MHz	39	2441 MHz
40	2442 MHz	41	2443 MHz	42	2444 MHz	43	2445 MHz
44	2446 MHz	45	2447 MHz	46	2448 MHz	47	2449 MHz
48	2450 MHz	49	2451 MHz	50	2452 MHz	51	2453 MHz
52	2454 MHz	53	2455 MHz	54	2456 MHz	55	2457 MHz
56	2458 MHz	57	2459 MHz	58	2460 MHz	59	2461 MHz
60	2462 MHz	61	2463 MHz	62	2464 MHz	63	2465 MHz
64	2466 MHz	65	2467 MHz	66	2468 MHz	67	2469 MHz
68	2470 MHz	69	2471 MHz	70	2472 MHz	71	2473 MHz
72	2474 MHz	73	2475 MHz	74	2476 MHz	75	2477 MHz
76	2478 MHz	77	2479 MHz	78	2480 MHz	N/A	N/A

Bluetooth Working Frequency of Each Channel: (For V4.0)							
Channel	Frequency	Channel	Frequency	Channel	Frequency	Channel	Frequency
00	2402 MHz	01	2404 MHz	02	2406 MHz	03	2408 MHz
04	2410 MHz	05	2412 MHz	06	2414 MHz	07	2416 MHz
08	2418 MHz	09	2420 MHz	10	2422 MHz	11	2424 MHz
12	2426 MHz	13	2428 MHz	14	2430 MHz	15	2432 MHz
16	2434 MHz	17	2436 MHz	18	2438 MHz	19	2440 MHz
20	2442 MHz	21	2444 MHz	22	2446 MHz	23	2448 MHz
24	2450 MHz	25	2452 MHz	26	2454 MHz	27	2456 MHz
28	2458 MHz	29	2460 MHz	30	2462 MHz	31	2464 MHz
32	2466 MHz	33	2468 MHz	34	2470 MHz	35	2472 MHz
36	2474 MHz	37	2476 MHz	38	2478 MHz	39	2480 MHz

Bluetooth Antenna List

Antenna	Manufacturer	Model No.	Peak Gain
PIFA Antenna	Goertek	N/A	1.2dBi for 2.4GHz

1.1. Mode of Operation

QuieTek has verified the construction and function in typical operation. All the test modes were carried out with the EUT in normal operation, which was shown in this test report and defined as:

Test Mode
Mode 1: Transmitter-1Mbps(GFSK_DH5)
Mode 2: Transmitter-2Mbps(Pi/4 DQPSK_DH5)
Mode 3: Transmitter-3Mbps(8DPSK_DH5)

Note:

1. Regards to the frequency band operation: the lowest, middle and highest frequency of channel were selected to perform the test, then shown on this report.
2. For portable device, radiated spurious emission was verified over X, Y, Z axis, and shown the worst case on this report.

1.2. Tested System Details

The types for all equipments, plus descriptions of all cables used in the tested system (including inserted cards) are:

Product	Manufacturer	Model No.	Serial No.	Power Cord
1 Notebook	Asus	N80V	8BN0AS226971468	N/A

1.3. Configuration of Tested System

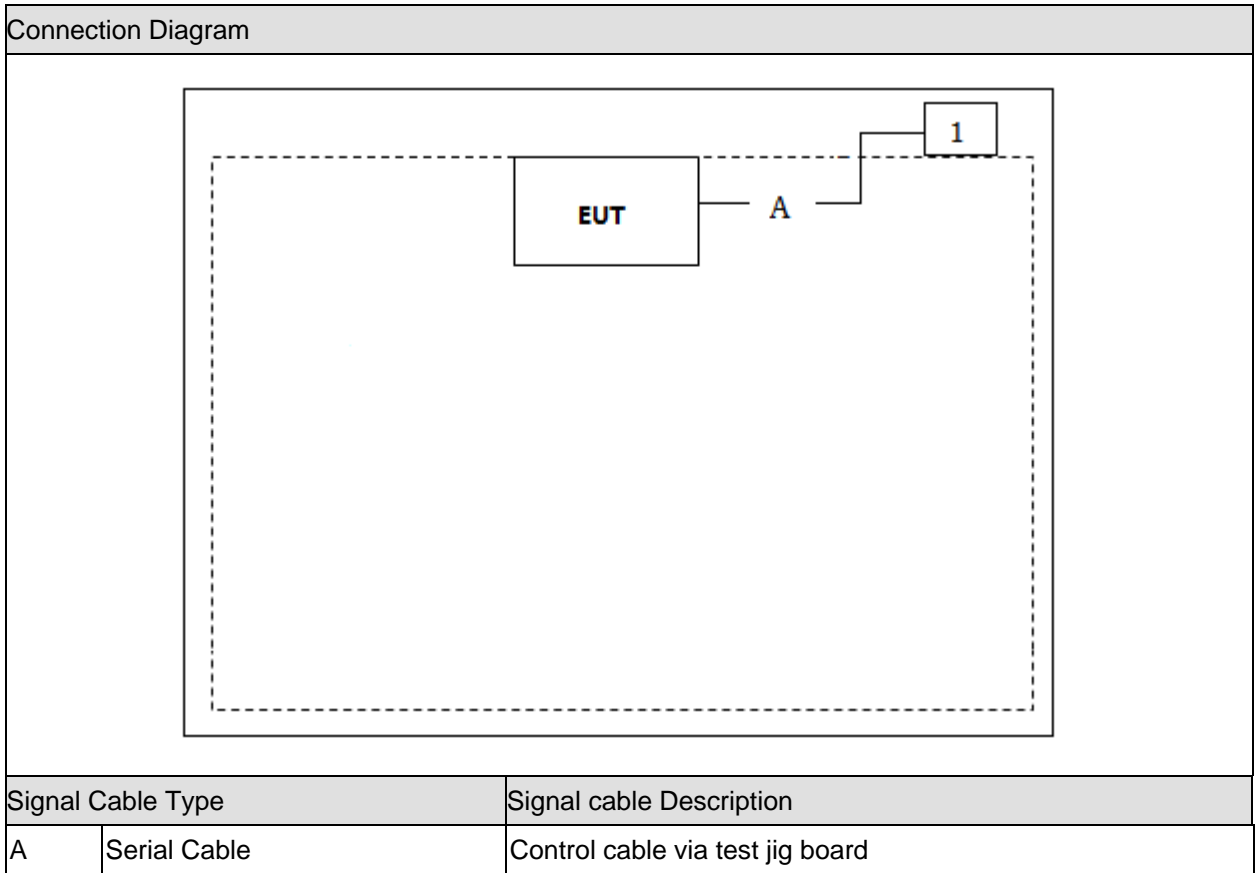

1.4. EUT Exercise Software

1	Setup the EUT and simulators as shown on above.
2	Turn on the power of all equipment.
3	Input the RF commands, and set the test mode and channel, then press OK to start continue Transmit.

2. Technical Test

2.1. Summary of Test Result

No deviations from the test standards

Deviations from the test standards as below description:

Performed Test Item	Normative References	Test Performed	Deviation
Conducted Emission	FCC CFR Title 47 Part 15 Subpart C: 2015 Section 15.207	Yes	No
Radiated Emission	FCC CFR Title 47 Part 15 Subpart C: 2015 Section 15.209	Yes	No
20dB Bandwidth	FCC CFR Title 47 Part 15 Subpart C: 2015 Section 15.247(a)(1)	Yes	No
Carrier Frequency Separation	FCC CFR Title 47 Part 15 Subpart C: 2015 Section 15.247(a)(1)	Yes	No
Number of Hopping Frequencies	FCC CFR Title 47 Part 15 Subpart C: 2015 Section 15.247(a)(1)(iii)	Yes	No
Time of Occupancy (Dwell Time)	FCC CFR Title 47 Part 15 Subpart C: 2015 Section 15.247(a)(1)(iii)	Yes	No
Peak Output Power	FCC CFR Title 47 Part 15 Subpart C: 2015 Section 15.247(b)(1)	Yes	No
Band-edge Compliance of RF Conducted Emissions	FCC CFR Title 47 Part 15 Subpart C: 2015 Section 15.215(c), 15.247(d)	Yes	No
Spurious RF Conducted Emissions	FCC CFR Title 47 Part 15 Subpart C: 2015 15.247(d)	Yes	No
Radiated Emission Band Edge	FCC CFR Title 47 Part 15 Subpart C: 2015 15.247(d)	Yes	No

Performed Test Item	Normative References	Test Performed	Deviation
Conducted Emission	RSS-Gen Issue 4 November 2014 Section 8.8	Yes	No
Radiated Emission	RSS-247 Issue 1 May 2015 Section 5.5	Yes	No
RF Antenna Conducted Spurious	RSS-247 Issue 1 May 2015 Section 5.5	Yes	No
Radiated Emission Band Edge	RSS-Gen Issue 4 November 2014 Section 8.10	Yes	No
Occupied Bandwidth	RSS-Gen Issue 4 November 2014 Section 6.6 RSS-247 Issue 1 May 2015 Section 5.2	Yes	No
Power Output	RSS-247 Issue 1 May 2015 Section 5.4	Yes	No

2.2. Test Environment

Items	Required (IEC 68-1)	Actual
Temperature (°C)	15-35	21
Humidity (%RH)	25-75	50
Barometric pressure (mbar)	860-1060	950-1000

3. Conducted Emission

3.1. Test Equipment

Conducted Emission / TR-1

Instrument	Manufacturer	Type No.	Serial No.	Cal. Due Date
EMI Test Receiver	R&S	ESCI	100726	2016.03.10
Two-Line V-Network	R&S	ENV216	100043	2016.03.10
Two-Line V-Network	R&S	ENV216	100044	2015.09.16
50ohm Coaxial Switch	Anritsu	MP59B	6200464462	2016.03.01
50ohm Termination	SHX	TF2	07081401	2015.09.16
Temperature/Humidity Meter	zhicheng	ZC1-2	TR1-TH	2016.01.07

Note: All equipments are calibrated with traceable calibrations. Each calibration is traceable to the national or international standards.

3.2. Test Setup

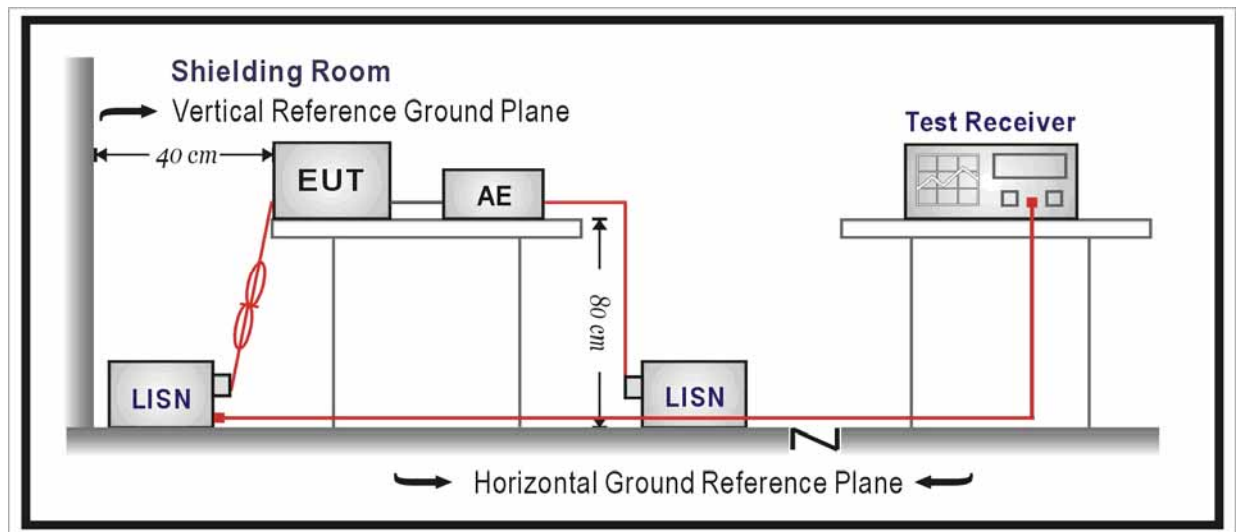

3.3. Limit

FCC Part 15 Subpart C Paragraph 15.207 Limits		
Frequency (MHz)	QP (dBuV)	AV (dBuV)
0.15 - 0.50	66 - 56	56 - 46
0.50 - 5.0	56	46
5.0 - 30	60	50

Note 1: The lower limit shall apply at the transition frequencies.

Note 2: The limit decreases linearly with the logarithm of the frequency in the range 0.15 MHz to 0.5 MHz.

3.4. Test Procedure

According to FCC ANSI C63.4: 2014 & ANSI C63.10: 2013.

The EUT was placed on a platform of nominal size, 1 m by 1.5 m, raised 80 cm above the conducting ground plane. The vertical conducting plane was located 40 cm to the rear of the EUT. All other surfaces of EUT were at least 80 cm from any other grounded conducting surface. The EUT and simulators are connected to the main power through a line impedance stabilization network (LISN). The LISN provides a 50 ohm /50uH coupling impedance for the measuring equipment. The peripheral devices are also connected to the main power through a LISN. (Please refer to the block diagram of the test setup and photographs)

Each current-carrying conductor of the EUT power cord, except the ground (safety) conductor, was individually connected through a LISN to the input power source.

The excess length of the power cord between the EUT and the LISN receptacle were folded back and forth at the center of the lead to form a bundle not exceeding 40 cm in length.

Conducted emissions were investigated over the frequency range from 0.15MHz to 30MHz using a receiver bandwidth of 9kHz.

3.5. Uncertainty

The measurement uncertainty is defined as ± 2.02 dB

3.6. Test Result

Engineer: Scott	
Site: TR1	Time: 2015/07/03
Limit: FCC_Part15.207_CE_AC Power_ClassB	Margin: 0
Probe: ENV216_101044(0.009-30MHz)	Polarity: Line
EUT: Zipp	Power: AC 120V/60Hz
Note: Mode 1	

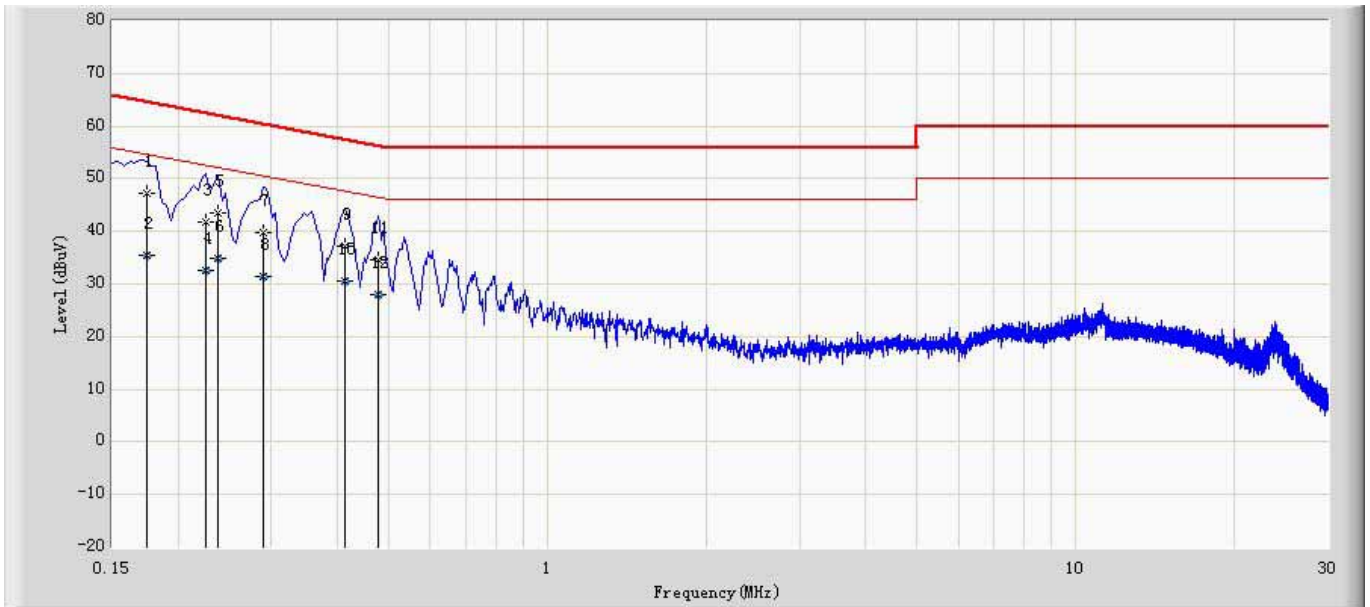

No	Mark	Frequency (MHz)	Measure Level (dBuV)	Reading Level (dBuV)	Over Limit (dB)	Limit (dBuV)	Factor (dB)	Type
1		0.174	47.246	37.526	-17.521	64.767	9.720	QP
2		0.174	35.395	25.675	-19.372	54.767	9.720	AV
3		0.226	41.821	32.111	-20.774	62.595	9.710	QP
4		0.226	32.668	22.958	-19.927	52.595	9.710	AV
5		0.238	43.376	33.666	-18.790	62.166	9.710	QP
6		0.238	34.918	25.208	-17.248	52.166	9.710	AV
7		0.290	39.694	29.994	-20.830	60.524	9.700	QP
8		0.290	31.536	21.836	-18.988	50.524	9.700	AV
9		0.414	37.305	27.602	-20.263	57.568	9.703	QP
10	*	0.414	30.516	20.813	-17.052	47.568	9.703	AV
11		0.478	34.669	24.969	-21.705	56.374	9.700	QP
12		0.478	28.132	18.432	-18.242	46.374	9.700	AV

Engineer: Scott	
Site: TR1	Time: 2015/07/03
Limit: FCC_Part15.207_CE_AC Power_ClassB	Margin: 0
Probe: ENV216_101044(0.009-30MHz)	Polarity: Neutral
EUT: Zipp	Power: AC 120V/60Hz
Note: Mode 1	

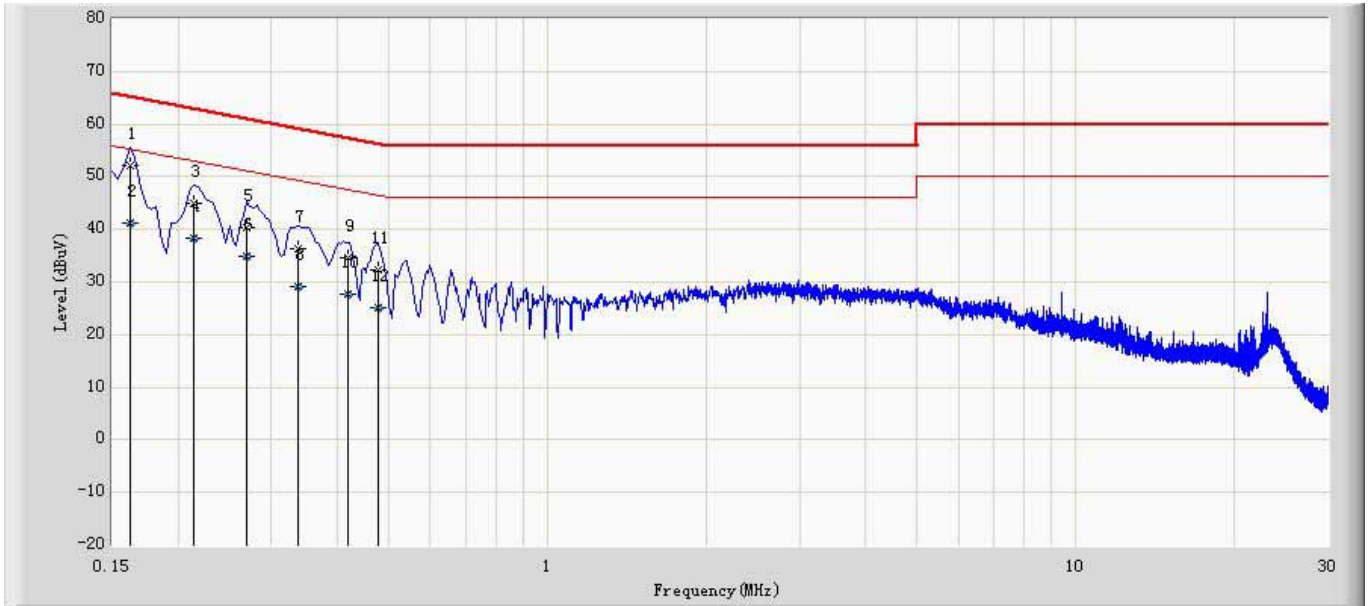

No	Mark	Frequency (MHz)	Measure Level (dBuV)	Reading Level (dBuV)	Over Limit (dB)	Limit (dBuV)	Factor (dB)	Type
1	*	0.162	52.096	42.367	-13.265	65.361	9.729	QP
2		0.162	41.097	31.368	-14.264	55.361	9.729	AV
3		0.214	44.909	35.189	-18.140	63.049	9.720	QP
4		0.214	38.247	28.527	-14.802	53.049	9.720	AV
5		0.270	40.431	30.718	-20.687	61.118	9.713	QP
6		0.270	34.872	25.159	-16.246	51.118	9.713	AV
7		0.338	36.383	26.673	-22.869	59.252	9.710	QP
8		0.338	29.099	19.389	-20.153	49.252	9.710	AV
9		0.418	34.538	24.828	-22.950	57.488	9.710	QP
10		0.418	27.667	17.957	-19.821	47.488	9.710	AV
11		0.478	32.206	22.506	-24.168	56.374	9.700	QP
12		0.478	25.069	15.369	-21.305	46.374	9.700	AV

Note: All the test modes are pretested and mode 1 was found to be the worst mode, so the data of this test mode was recorded.

4. Radiated Emission

4.1. Test Equipment

Radiated Emission / AC-2

Instrument	Manufacturer	Type No.	Serial No.	Cal. Due Date
EMI Test Receiver	R&S	ESCI	100573	2016.03.10
Loop Antenna	R&S	HFH2-Z2	833799/003	2015.11.25
Bilog Antenna	Teseq GmbH	CBL6112D	27611	2015.10.10
Coaxial Cable	Huber+Suhner	SUCOFLEX 106	AC2-C	2016.03.01
Temperature/Humidity Meter	Zhicheng	ZC1-2	AC2-TH	2016.01.07

Radiated Emission / AC-5

Instrument	Manufacturer	Type No.	Serial No.	Cal. Due Date
Spectrum Analyzer	Agilent	N9010A	MY48030494	2016.03.10
Preamplifier	Miteq	NSP1800-25	1364185	2016.05.03
Preamplifier	Quietek	AP-040G	CHM-0906001	2016.05.03
Bilog Antenna	Teseq GmbH	CBL6112D	27612	2015.10.15
Broad-Band Horn Antenna	Schwarzbeck	BBHA9120D	499	2016.06.08
Broad-Band Horn Antenna	Schwarzbeck	BBHA9170	294	2016.04.10
Coaxial Cable	Huber+Suhner	SUCOFLEX 106	AC5-C1	2016.03.01
Coaxial Cable	Huber+Suhner	SUCOFLEX 106	AC5-C2	2016.03.01
Coaxial Cable	Huber+Suhner	SUCOFLEX 102	AC5-C3	2016.03.01
Temperature/Humidity Meter	Zhicheng	ZC1-2	AC5-TH	2016.01.07

4.2. Test Setup

Below 30MHz Test Setup:

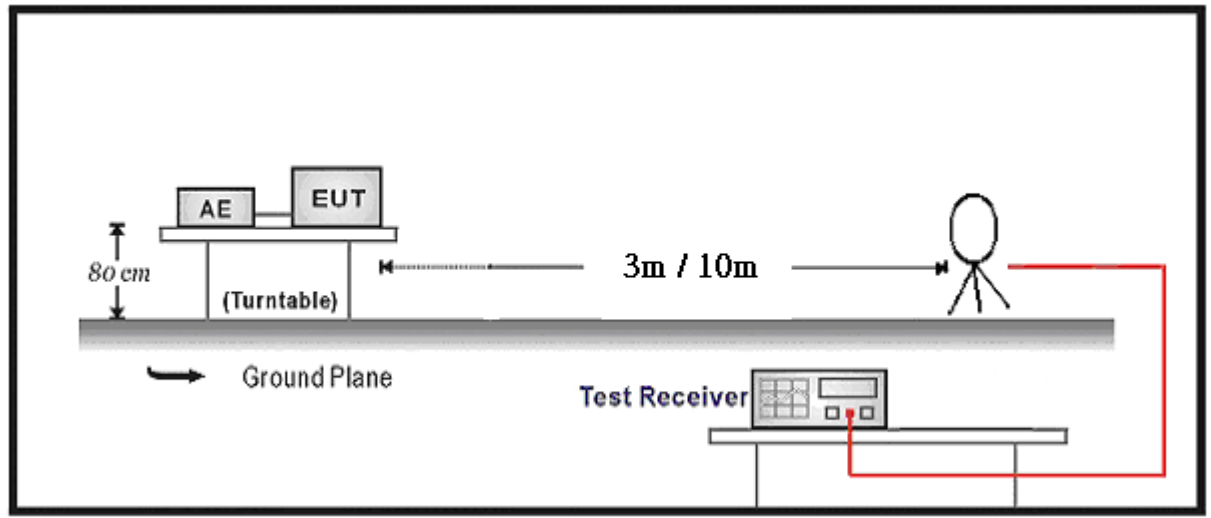

Below 1GHz Test Setup:

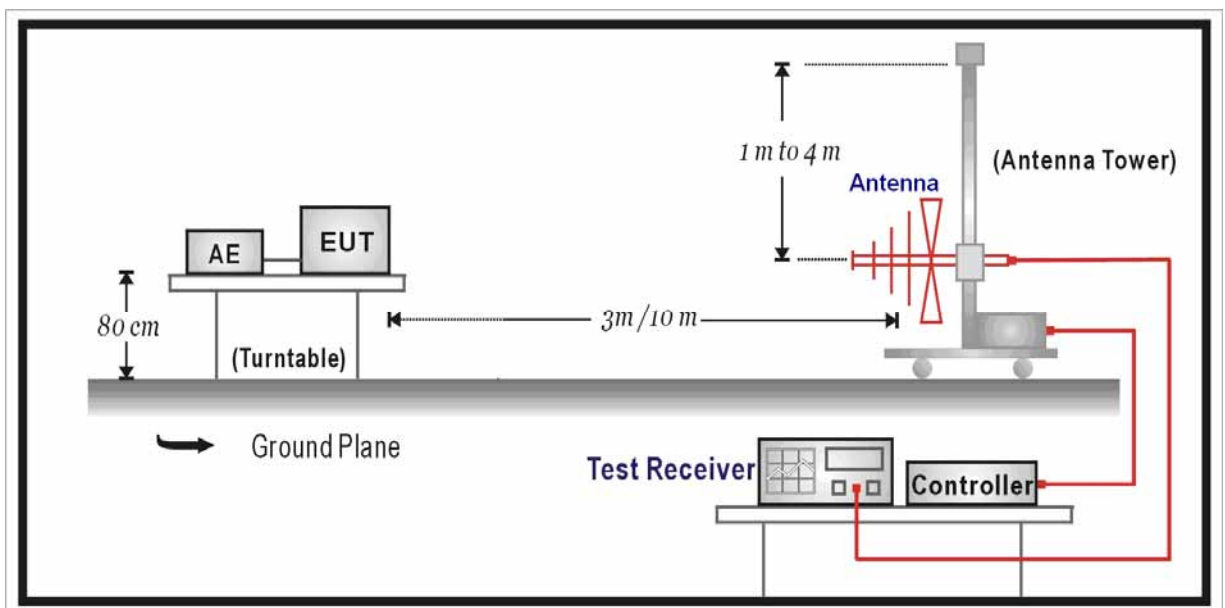

Above 1GHz Test Setup:

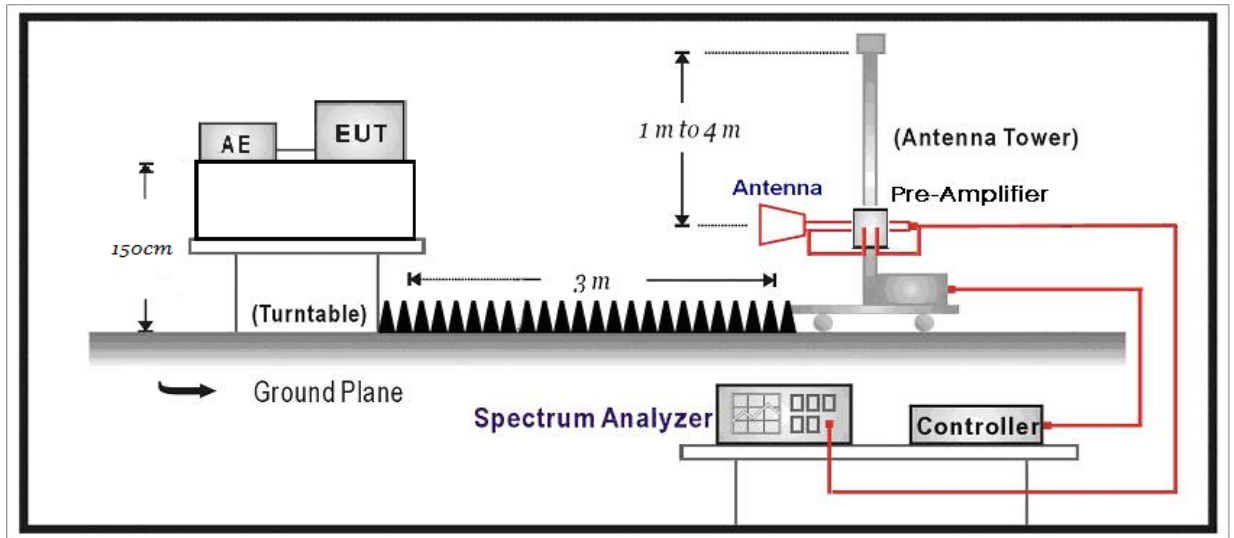

4.3. Limit

FCC Part 15 Subpart C Paragraph 15.209		
Frequency (MHz)	Distance (m)	Level (dBuV/m)
30 - 88	3	40
88 - 216	3	43.5
216 - 960	3	46
Above 960	3	54

Note 1: The lower limit shall apply at the transition frequency.

Note 2: Distance refers to the distance in meters between the measuring instrument antenna and the closed point of any part of the device or system.

Note 3: E field strength (dBuV/m) = 20 log E field strength (uV/m)

4.4. Test Procedure

According to ANSI C63.4: 2014; ANSI C63.10: 2013.

The EUT is placed on a turn table which is 1.5 meter for above 1G and 0.8 meter for below 1G above ground. The turn table is rotated 360 degrees to determine the position of the maximum emission level. The EUT was positioned such that the distance from antenna to the EUT was 3 meters.

The antenna is scanned from 1 meter to 4 meters to find out the maximum emission level.

This is repeated for both horizontal and vertical polarization of the antenna. In order to find the maximum emission, all of the interface cables were manipulated according to ANSI C63.4: 2014 on radiated measurement.

The resolution bandwidth below 1GHz setting on the field strength meter is 120 kHz and above 1GHz is 1MHz.

The frequency range from 30MHz to 10th harmonic is checked.

Note: When doing emission measurement above 1GHz, the horn antenna will be bended down a little (as horn antenna has the narrow beamwidth) in order to keeping the antenna in the “cone of radiation” of EUT. The 3dB beamwidth is 60~10 degrees for H-plane and 90~10 degrees for E-plane.

4.5. Uncertainty

The measurement uncertainty above 1G is defined as ± 3.9 dB
below 1G is defined as ± 3.8 dB

4.6. Test Result

All of the test result shown indicates the worst case, and spectrum analyzer parameters setting as shown below:

Peak detector: RBW = 1MHz, VBW = 3MHz, sweep time = 200ms;

Average detector: RBW = 1MHz, VBW = 10Hz, sweep time = auto.

Measure Level = Reading Level + Cable Loss + Antenna Factor – Preamplifier Gain

Mode 1: Transmitter-1Mbps(GFSK_DH5)

CH	Antenna	Frequency (MHz)	Reading Level (dBuV/m)	Factor (dB)	Measure Level (dBuV/m)	Limit (dBuV/m)	Margin (dB)	Detector
0	H	4799.5	37.2	7.7	44.9	54(Note3)	-9.1	PK
	V	4799.5	38.9	7.7	46.6	54(Note3)	-7.4	PK
	H	7206.0	29.8	12.6	42.4	54(Note3)	-11.6	PK
	V	7206.0	28.6	12.6	41.2	54(Note3)	-12.8	PK
	H	9608.0	27.2	15.1	42.3	54(Note3)	-11.7	PK
	V	9608.0	27.0	15.1	42.1	54(Note3)	-11.9	PK
39	H	4884.5	37.6	7.8	45.4	54(Note3)	-8.6	PK
	V	4884.5	37.8	7.8	45.6	54(Note3)	-8.4	PK
	H	7323.0	29.0	12.9	41.9	54(Note3)	-12.1	PK
	V	7323.0	28.7	12.9	41.6	54(Note3)	-12.4	PK
	H	9764.0	26.5	15.4	41.9	54(Note3)	-12.1	PK
	V	9764.0	27.6	15.4	43.0	54(Note3)	-11.0	PK
78	H	4961.0	34.0	7.9	41.9	54(Note3)	-12.1	PK
	V	4961.0	35.5	7.9	43.4	54(Note3)	-10.6	PK
	H	7440.0	29.8	13.3	43.1	54(Note3)	-10.9	PK
	V	7440.0	28.7	13.3	42.0	54(Note3)	-12.0	PK
	H	9920.0	26.4	14.9	41.3	54(Note3)	-12.7	PK
	V	9920.0	26.6	14.9	41.5	54(Note3)	-12.5	PK

Note: 1. Measure Level = Reading Level + Factor.

2. The test frequency range, 9kHz~30MHz, 18GHz~25GHz, both of the worst case are at least 6dB below the limits, therefore no data appear in the report.
3. This limit applies for using average detector, if the test result on peak is lower than average limit, then average measurement needn't be performed.

Mode 2: Transmitter-2Mbps(Pi/4 DQPSK _DH5)

CH	Antenna	Frequency (MHz)	Reading Level (dBuV/m)	Factor (dB)	Measure Level (dBuV/m)	Limit (dBuV/m)	Margin (dB)	Detector
0	H	4799.5	38.1	7.7	45.8	54(Note3)	-8.2	PK
	V	4808.0	36.5	7.7	44.2	54(Note3)	-9.8	PK
	H	7206.0	29.0	12.6	41.6	54(Note3)	-12.4	PK
	V	7206.0	28.7	12.6	41.3	54(Note3)	-12.7	PK
	H	9608.0	27.1	15.1	42.2	54(Note3)	-11.8	PK
	V	9608.0	27.0	15.1	42.1	54(Note3)	-11.9	PK
39	H	4884.5	34.5	7.8	42.3	54(Note3)	-11.7	PK
	V	4884.5	35.8	7.8	43.6	54(Note3)	-10.4	PK
	H	7323.0	28.7	12.9	41.6	54(Note3)	-12.4	PK
	V	7323.0	29.2	12.9	42.1	54(Note3)	-11.9	PK
	H	9764.0	27.4	15.4	42.8	54(Note3)	-11.2	PK
	V	9764.0	27.6	15.4	43.0	54(Note3)	-11.0	PK
78	H	4961.0	33.4	7.9	41.3	54(Note3)	-12.7	PK
	V	4961.0	34.8	7.9	42.7	54(Note3)	-11.3	PK
	H	7440.0	29.2	13.3	42.5	54(Note3)	-11.5	PK
	V	7440.0	28.9	13.3	42.2	54(Note3)	-11.8	PK
	H	9920.0	27.3	14.9	42.2	54(Note3)	-11.8	PK
	V	9920.0	26.9	14.9	41.8	54(Note3)	-12.2	PK

Note: 1. Measure Level = Reading Level + Factor.

2. The test frequency range, 9kHz~30MHz, 18GHz~25GHz, both of the worst case are at least 6dB below the limits, therefore no data appear in the report.
3. This limit applies for using average detector, if the test result on peak is lower than average limit, then average measurement needn't be performed.

Mode 3: Transmitter-3Mbps(8DPSK_DH5)

CH	Antenna	Frequency (MHz)	Reading Level (dBuV/m)	Factor (dB)	Measure Level (dBuV/m)	Limit (dBuV/m)	Margin (dB)	Detector
0	H	4808.0	36.8	7.7	44.5	54(Note3)	-9.5	PK
	V	4799.5	38.8	7.7	46.5	54(Note3)	-7.5	PK
	H	7206.0	28.4	12.6	41.0	54(Note3)	-13.0	PK
	V	7206.0	28.0	12.6	40.6	54(Note3)	-13.4	PK
	H	9608.0	26.1	15.1	41.2	54(Note3)	-12.8	PK
	V	9608.0	26.3	15.1	41.4	54(Note3)	-12.6	PK
39	H	4884.5	34.6	7.8	42.4	54(Note3)	-11.6	PK
	V	4884.5	36.2	7.8	44.0	54(Note3)	-10.0	PK
	H	7323.0	28.6	12.9	41.5	54(Note3)	-12.5	PK
	V	7323.0	28.7	12.9	41.6	54(Note3)	-12.4	PK
	H	9764.0	26.4	15.4	41.8	54(Note3)	-12.2	PK
	V	9764.0	27.4	15.4	42.8	54(Note3)	-11.2	PK
78	H	4960.0	33.0	8.0	41.0	54(Note3)	-13.0	PK
	V	4961.0	33.9	7.9	41.8	54(Note3)	-12.2	PK
	H	7440.0	28.6	13.3	41.9	54(Note3)	-12.1	PK
	V	7440.0	28.9	13.3	42.2	54(Note3)	-11.8	PK
	H	9920.0	26.5	14.9	41.4	54(Note3)	-12.6	PK
	V	9920.0	27.1	14.9	42.0	54(Note3)	-12.0	PK

Note: 1. Measure Level = Reading Level + Factor.

2. The test frequency range, 9kHz~30MHz, 18GHz~25GHz, both of the worst case are at least 6dB below the limits, therefore no data appear in the report.
3. This limit applies for using average detector, if the test result on peak is lower than average limit, then average measurement needn't be performed.

The worst case of Radiated Emission below 1GHz:

Engineer: Scott	
Site: AC2	Time: 2015/07/13
Limit: FCC_Part15.209_RE(3m)_ClassB	Margin: 0
Probe: AC2_10M(30-1000M)20150408	Polarity: Horizontal
EUT: Zipp	Power: AC 120V/60Hz
Note: Mode 1	

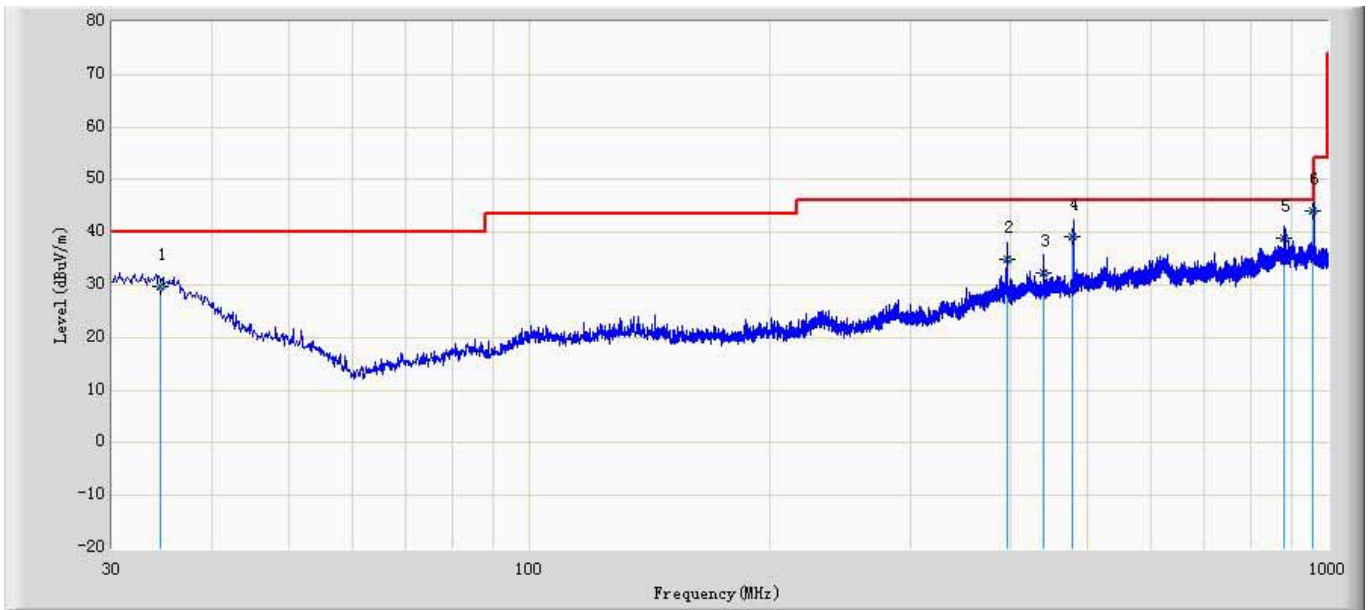

No	Mark	Frequency (MHz)	Measure Level (dBuV/m)	Reading Level (dBuV)	Over Limit (dB)	Limit (dBuV/m)	Factor (dB)	Type
1		34.540	29.759	36.119	-10.241	40.000	-6.360	QP
2		396.201	34.913	39.837	-11.087	46.000	-4.924	QP
3		440.121	32.436	36.164	-13.564	46.000	-3.728	QP
4		479.218	39.227	42.139	-6.773	46.000	-2.912	QP
5		883.011	39.025	37.993	-6.975	46.000	1.032	QP
6	*	959.120	43.977	41.876	-2.023	46.000	2.101	QP

Engineer: Scott	
Site: AC2	Time: 2015/07/13
Limit: FCC_Part15.209_RE(3m)_ClassB	Margin: 0
Probe: AC2_10M(30-1000M)20150408	Polarity: Vertical
EUT: Zipp	Power: AC 120V/60Hz
Note: Mode 1	

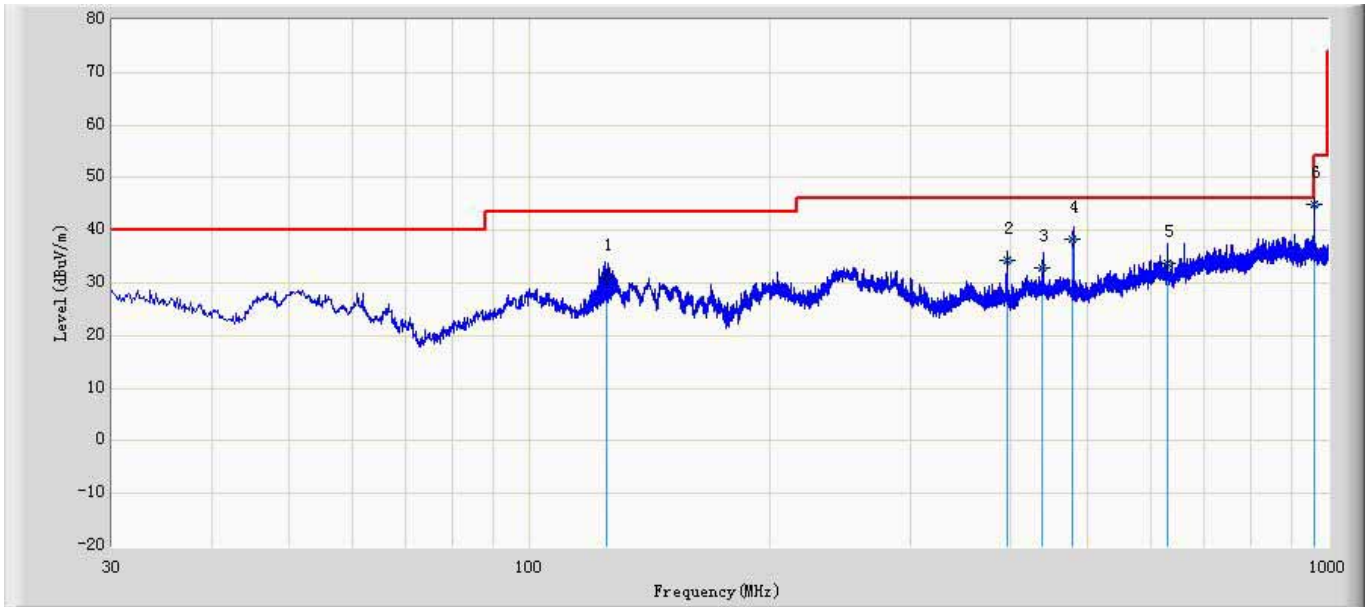

No	Mark	Frequency (MHz)	Measure Level (dBuV/m)	Reading Level (dBuV)	Over Limit (dB)	Limit (dBuV/m)	Factor (dB)	Type
1		124.900	31.041	40.717	-12.459	43.500	-9.676	QP
2		396.084	34.172	39.098	-11.828	46.000	-4.926	QP
3		439.044	32.761	36.516	-13.239	46.000	-3.755	QP
4		479.221	38.315	41.227	-7.685	46.000	-2.912	QP
5		630.001	33.857	34.586	-12.143	46.000	-0.729	QP
6	*	959.866	44.805	42.696	-1.195	46.000	2.109	QP

5. 20dB Bandwidth

5.1 Test Equipment

20dB Bandwidth / TR8

Instrument	Manufacturer	Type No.	Serial No.	Cal. Due Date
Spectrum Analyzer	Agilent	N9010A	MY48030494	2016.03.10
Temperature/Humidity Meter	Zhicheng	ZC1-2	TR8-TH	2016.04.09

Note: All equipments are calibrated with traceable calibrations. Each calibration is traceable to the national or international standards.

5.2 Test Setup

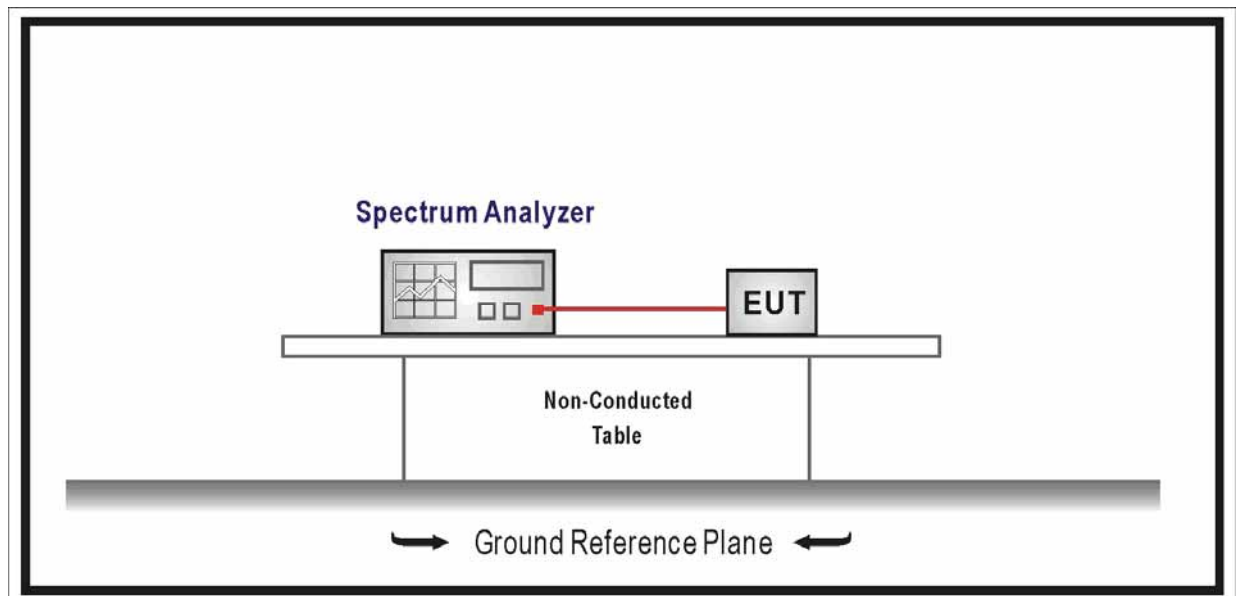

5.3 Limit

- For frequency hopping systems operating in 2400-2483.5 MHz band, no limitation.
- For frequency hopping systems operating in 902-928 MHz band, the maximum allowed 20 dB bandwidth of the hopping channel is 500 kHz.
- For frequency hopping systems operating in 5725-5850 MHz band, the maximum 20 dB bandwidth of the hopping channel is 1 MHz.

5.4 Test Procedure

According to ANSI C63.10: 2013& ANSI C63.4: 2014

Use the following spectrum analyzer settings:

Span = approximately 2 to 3 times the 20dB bandwidth, centered on a hopping channel

RBW \cong 1% of the 20dB bandwidth

VBW \cong RBW

Sweep = auto

Detector function = peak

Trace = max hold

The EUT should be transmitting at its maximum data rate. Allow the trace to stabilize.

Use the marker-to-peak function to set the marker to the peak of the emission. Use the marker-Zipp function to measure 20 dB down one side of the emission. Reset the marker-Zipp function, and move the marker to the other side of the emission, until it is (as close as possible to) even with the reference marker level. The marker-Zipp reading at this point is the 20 dB bandwidth of the emission. If this value varies with different modes of operation (e.g., data rate, modulation format, etc.), repeat this test for each variation.

5.5 Uncertainty

The measurement uncertainty is defined as ± 1 kHz

5.6 Test Result

Product	:	Zipp
Test Item	:	Occupied Bandwidth
Test Site	:	TR-8
Test Mode	:	Mode 1: Transmitter-1Mbps (GFSK_DH5)

Channel No.	Frequency (MHz)	20dB Bandwidth (kHz)	99% Bandwidth (kHz)
00	2402	927.6	874.66
39	2441	927.0	881.36
78	2480	923.9	873.15

Channel 00 (2402MHz)

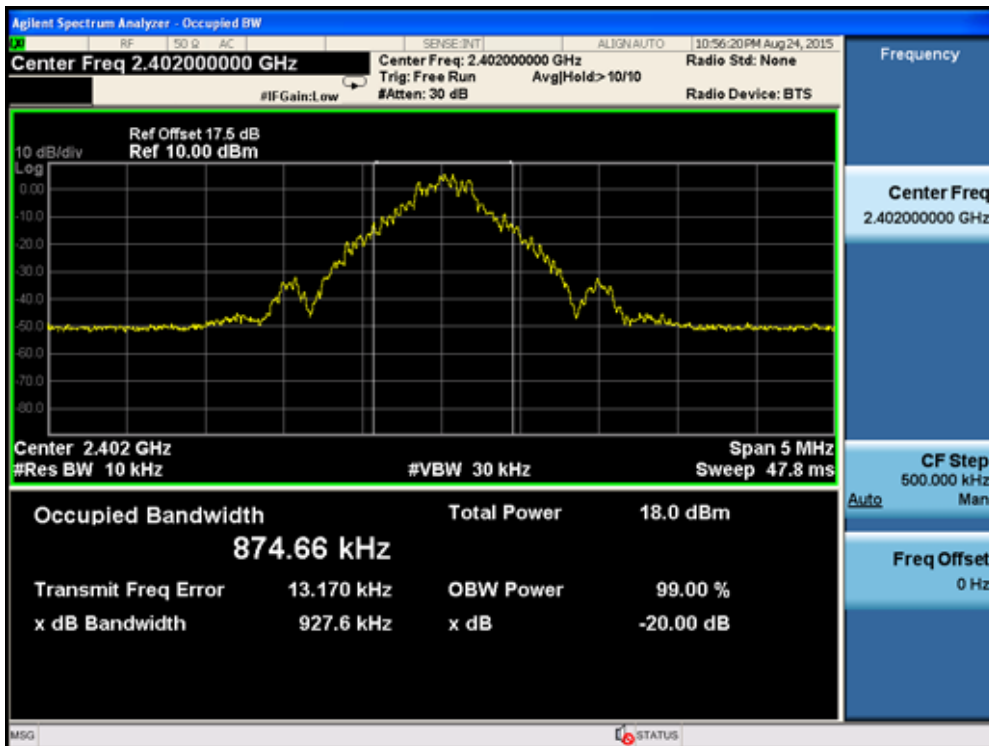

Channel 39 (2441MHz)

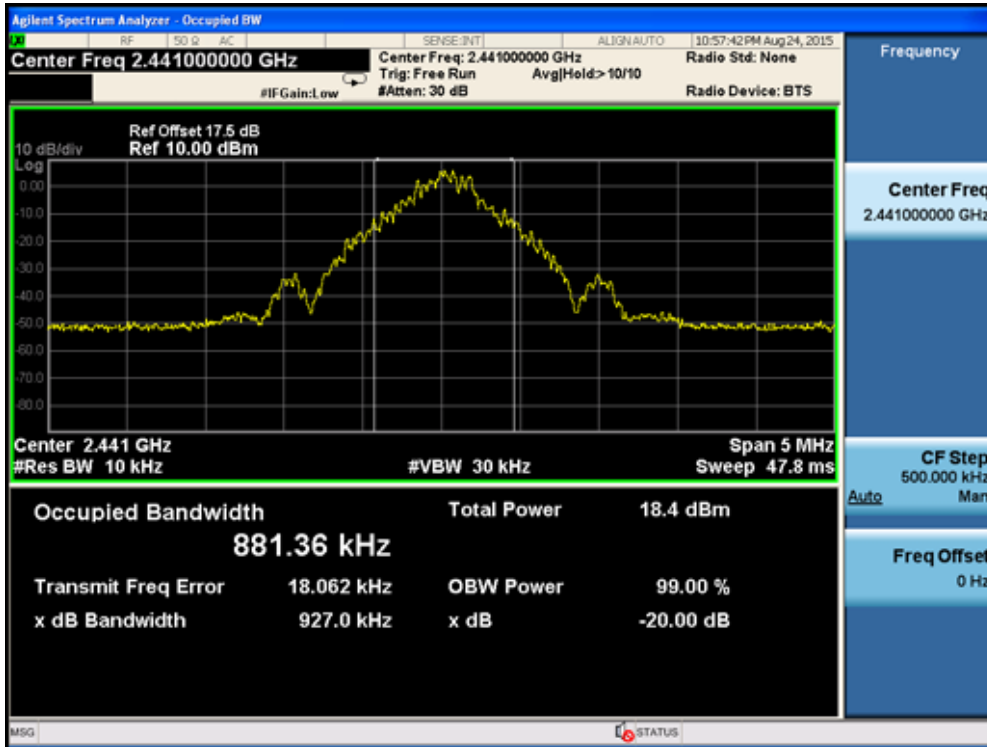

Channel 78 (2480MHz)

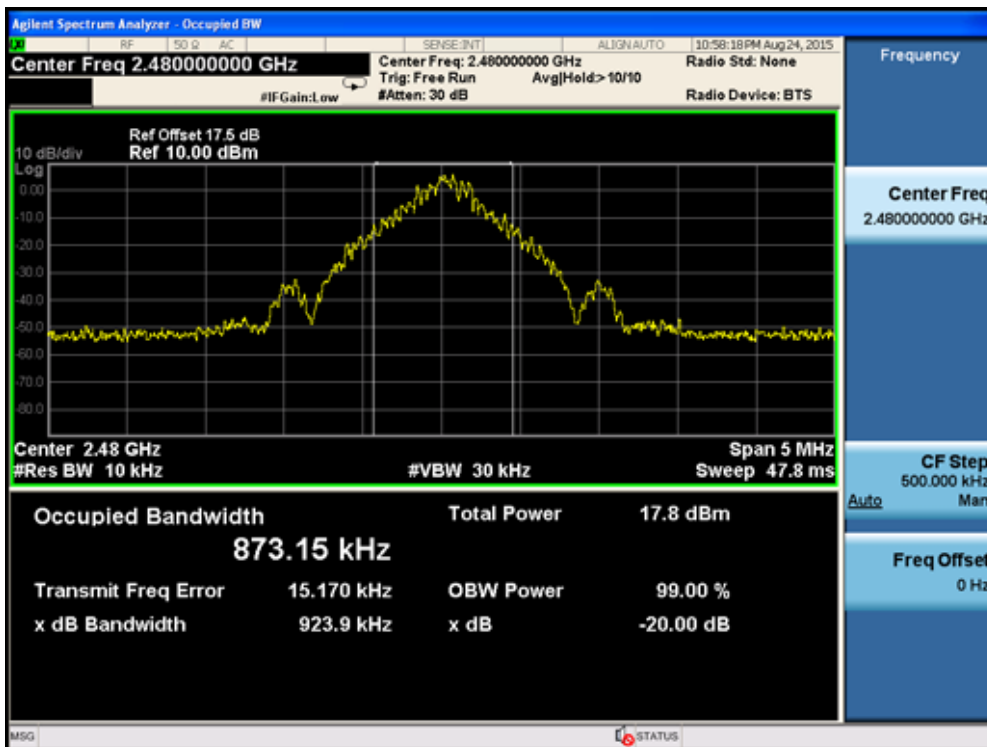

Product	:	Zipp
Test Item	:	Occupied Bandwidth
Test Site	:	TR-8
Test Mode	:	Mode 2: Transmitter-2Mbps (Pi/4 DQPSK_DH5)

Channel No.	Frequency (MHz)	20dB Bandwidth (kHz)	99% Bandwidth (kHz)
00	2402	1283	1170.7
39	2441	1319	1183.3
78	2480	1317	1176.7

Channel 00 (2402MHz)

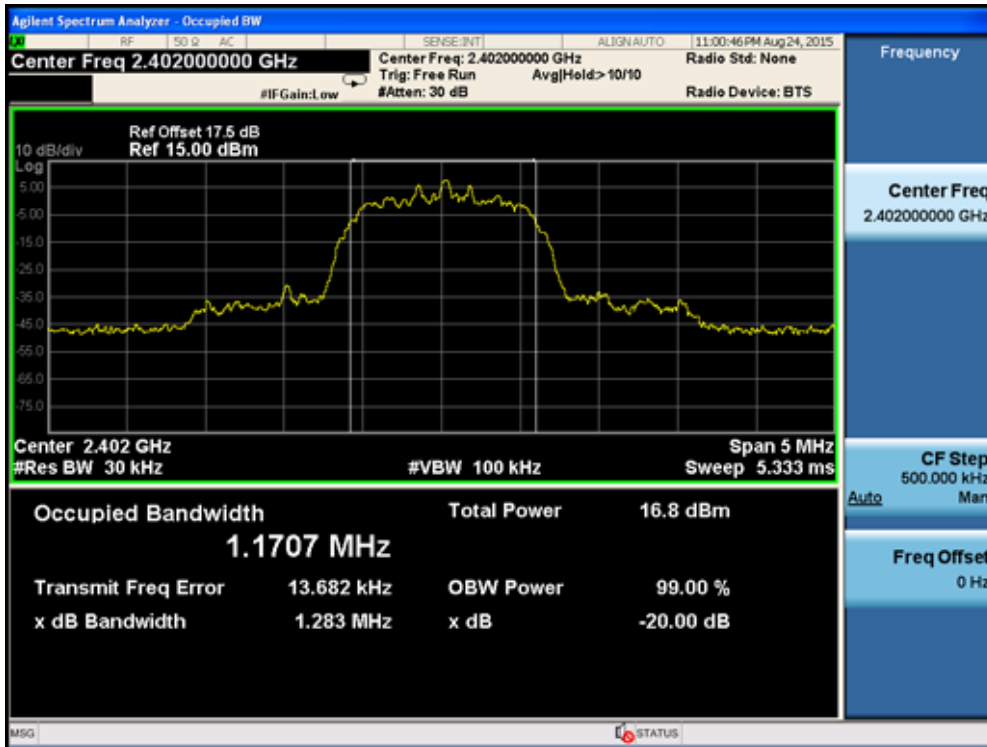

Channel 39 (2441MHz)

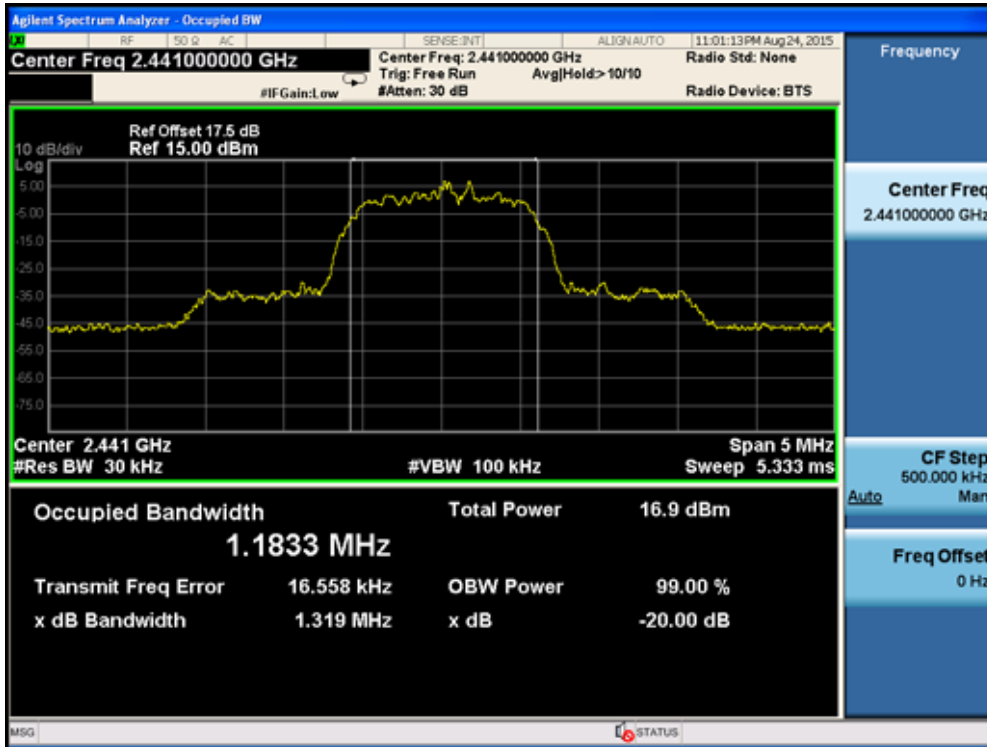

Channel 78 (2480MHz)

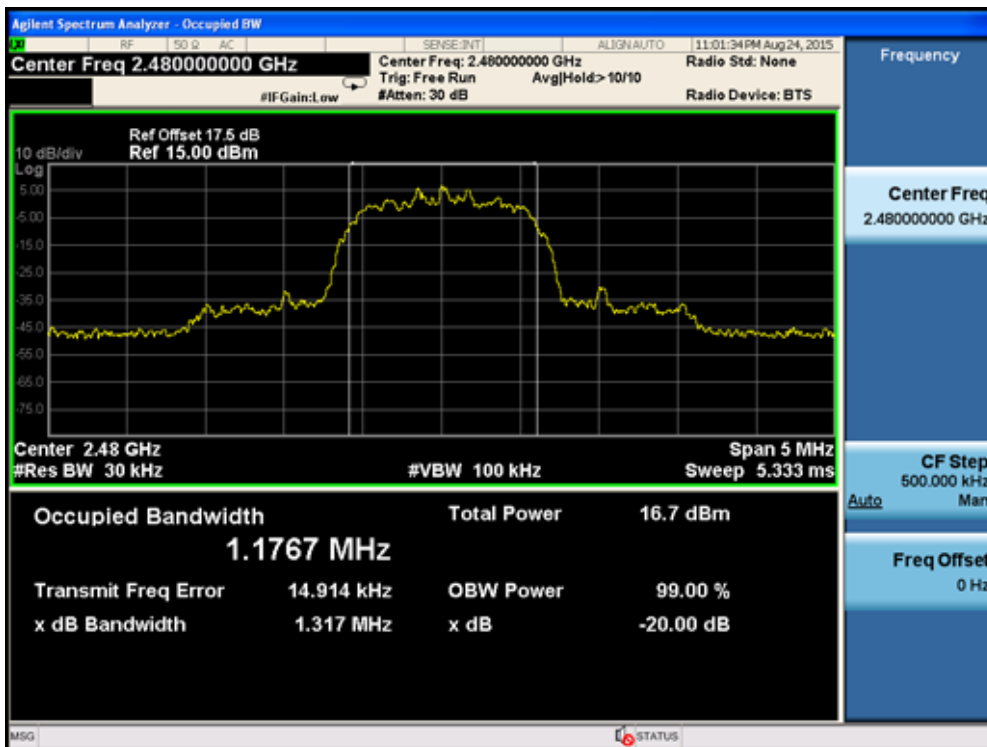

Product	:	Zipp
Test Item	:	Occupied Bandwidth
Test Site	:	TR-8
Test Mode	:	Mode 3: Transmitter-3Mbps (8DPSK_DH5)

Channel No.	Frequency (MHz)	20dB Bandwidth (kHz)	99% Bandwidth (kHz)
00	2402	1296	1174.9
39	2441	1302	1177.7
78	2480	1324	1190.4

Channel 00 (2402MHz)

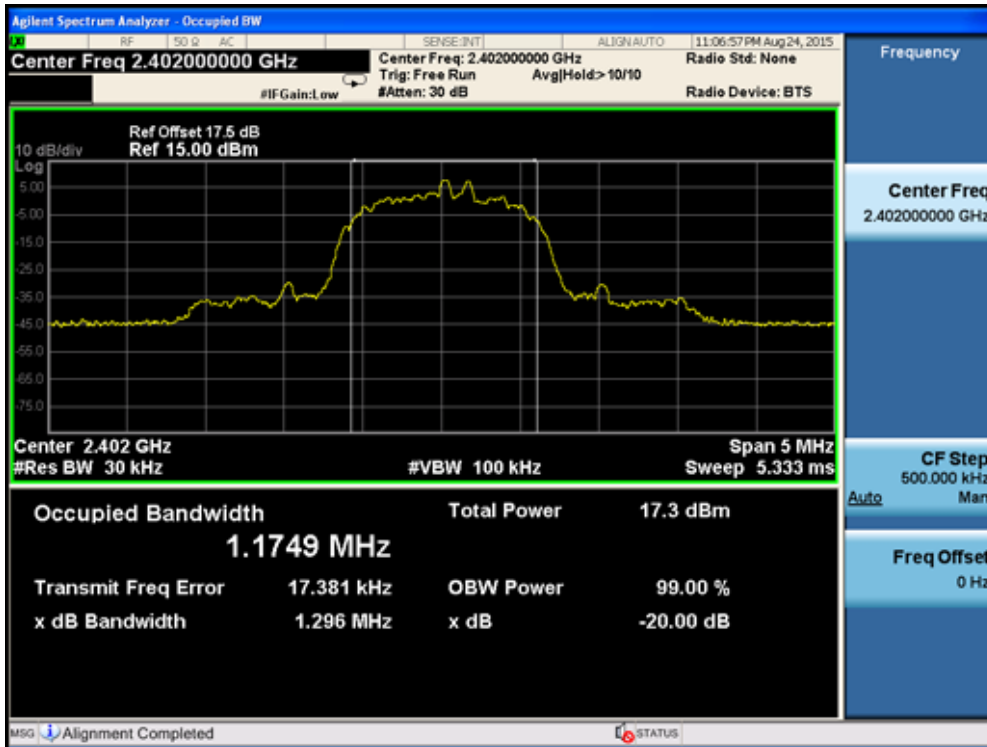

Channel 39 (2441MHz)

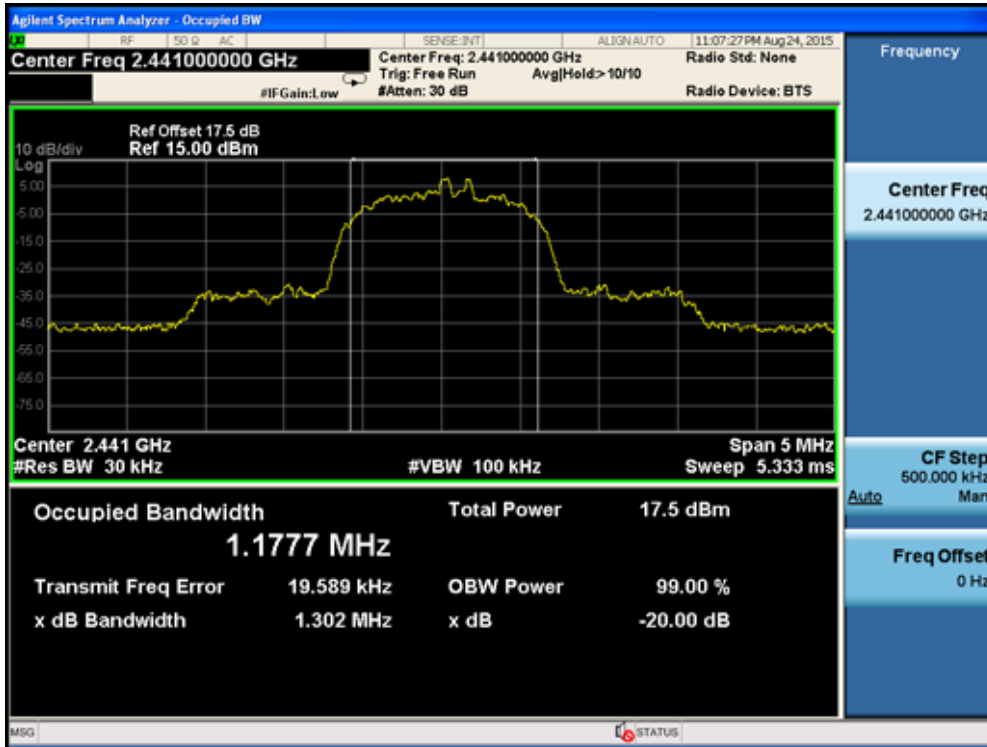

Channel 78 (2480MHz)



6. Carrier Frequency Separation

6.1. Test Equipment

Carrier Frequency Separation / TR-8

Instrument	Manufacturer	Type No.	Serial No.	Cal. Due Date
Spectrum Analyzer	Agilent	N9010A	MY48030494	2016.03.10
Temperature/Humidity Meter	Zhicheng	ZC1-2	TR8-TH	2016.04.09

Note: All equipments are calibrated with traceable calibrations. Each calibration is traceable to the national or international standards.

6.2. Test Setup

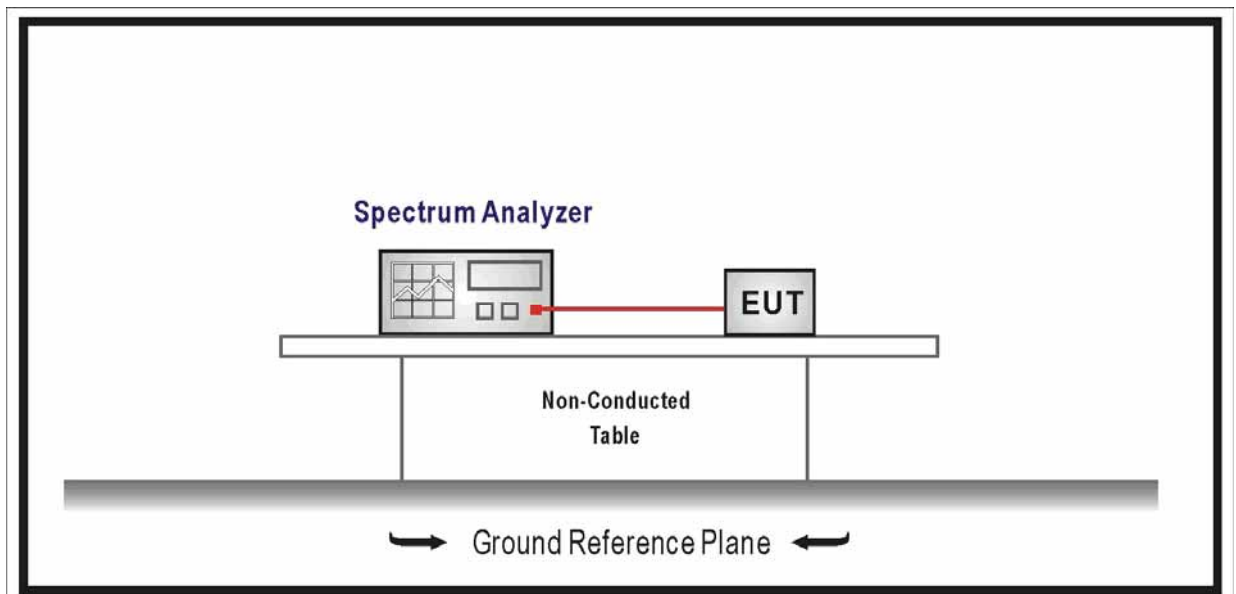

6.3. Limit

- Frequency hopping systems shall have hopping channel carrier frequencies separated by a minimum of 25 kHz or the 20 dB bandwidth of the hopping channel, whichever is greater. Alternatively, frequency hopping systems operating in the 2400-2483.5 MHz band may have hopping channel carrier frequencies that are separated by 25 kHz or two-thirds of the 20 dB bandwidth of the hopping channel, whichever is greater, provided the systems operate with an output power no greater than 125mW. The system shall hop to channel frequencies that are selected at the system hopping rate from a pseudorandomly ordered list of hopping frequencies. Each frequency must be used equally on the average by each transmitter. The system receivers shall have input bandwidths that match the hopping

channel bandwidths of their corresponding transmitters and shall shift frequencies in synchronization with the transmitted signals.

- For frequency hopping systems operating in the 902-928 MHz band: if the 20 dB bandwidth of the hopping channel is less than 250 kHz, the system shall use at least 50 hopping frequencies and the average time of occupancy on any frequency shall not be greater than 0.4 seconds within a 20 second period; If the 20 dB bandwidth of the hopping channel is 250 kHz or greater, the system shall use at least 25 hopping frequencies and the average time of occupancy on any frequency shall not be greater than 0.4 seconds within a 10 second period. The maximum allowed 20 dB bandwidth of the hopping channel is 500 kHz.
- Frequency hopping systems operating in the 5725-5850 MHz band shall use at least 75 hopping frequencies. The maximum 20 dB bandwidth of the hopping channel is 1 MHz. The average time of occupancy on any frequency shall not be greater than 0.4 seconds within a 30 second period.

6.4. Test Procedure

According to ANSI C63.10: 2013& ANSI C63.4: 2014

The EUT must have its hopping function enabled. Use the following spectrum analyzer settings:

Span = wide enough to capture the peaks of two adjacent channels

Resolution (or IF) Bandwidth (RBW) \geq 1% of the span

Video (or Average) Bandwidth VBW \geq RBW

Sweep = auto

Detector function = peak

Trace = max hold

Allow the trace to stabilize. Use the marker-Zipp function to determine the separation between the peaks of the adjacent channels.

6.5. Uncertainty

The measurement uncertainty is defined as ± 1 kHz

6.6. Test Result

Product	:	Zipp
Test Item	:	Carrier Frequency Separation
Test Site	:	TR-8
Test Mode	:	Mode 1: Transmitter-1Mbps (GFSK_DH5)

Channel No.	Frequency (MHz)	Carrier Frequency Separation (kHz)	Limit (kHz)	Result
00	2402	1000	>25 kHz or 2/3 of 20 dB BW	Pass
39	2441	1000	>25 kHz or 2/3 of 20 dB BW	Pass
78	2480	1000	>25 kHz or 2/3 of 20 dB BW	Pass

Channel 00 (2402MHz)

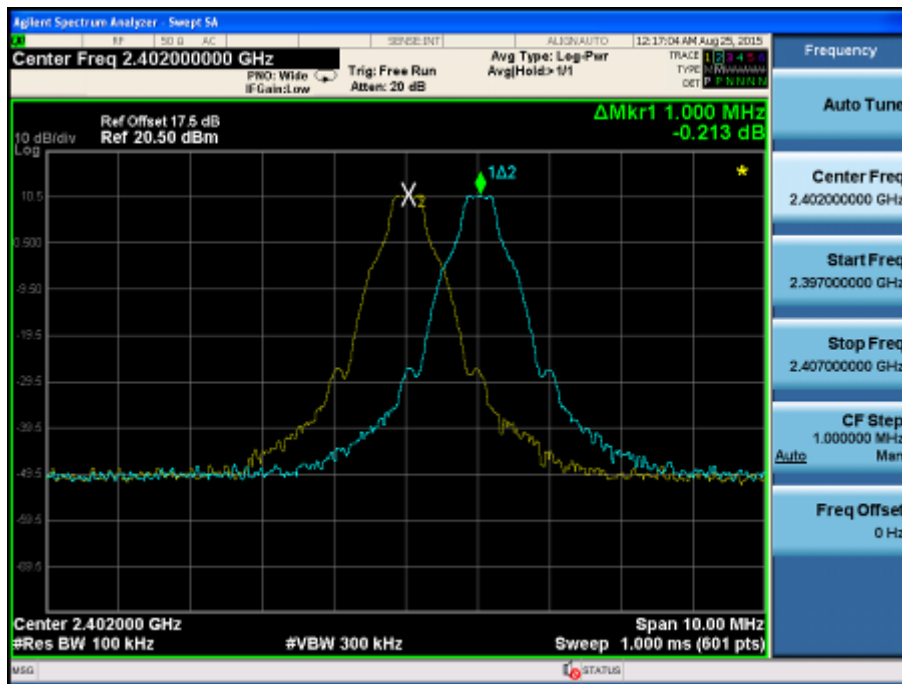

Channel 39 (2441MHz)

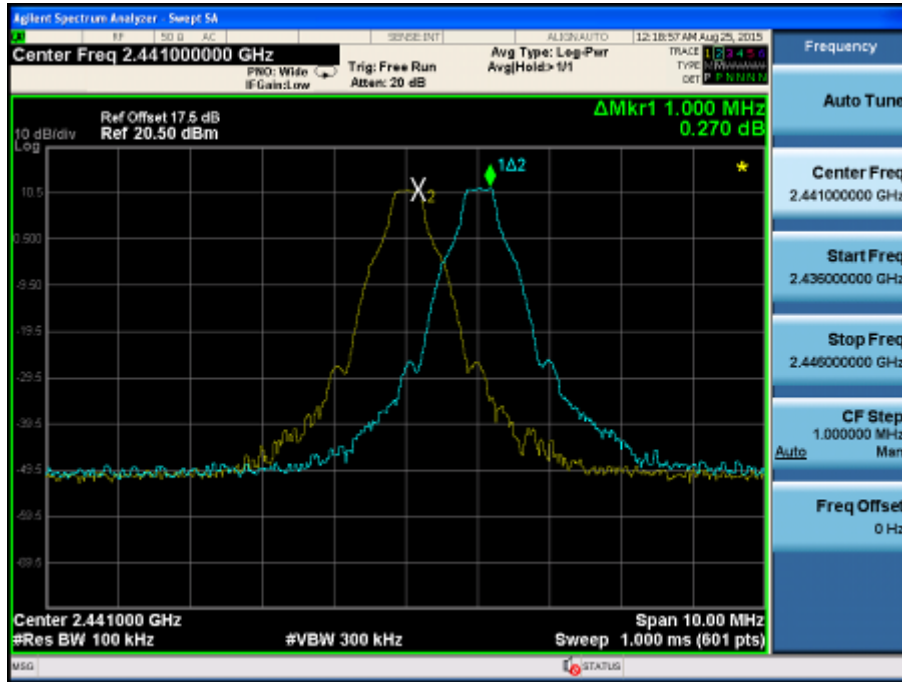

Channel 78 (2480MHz)

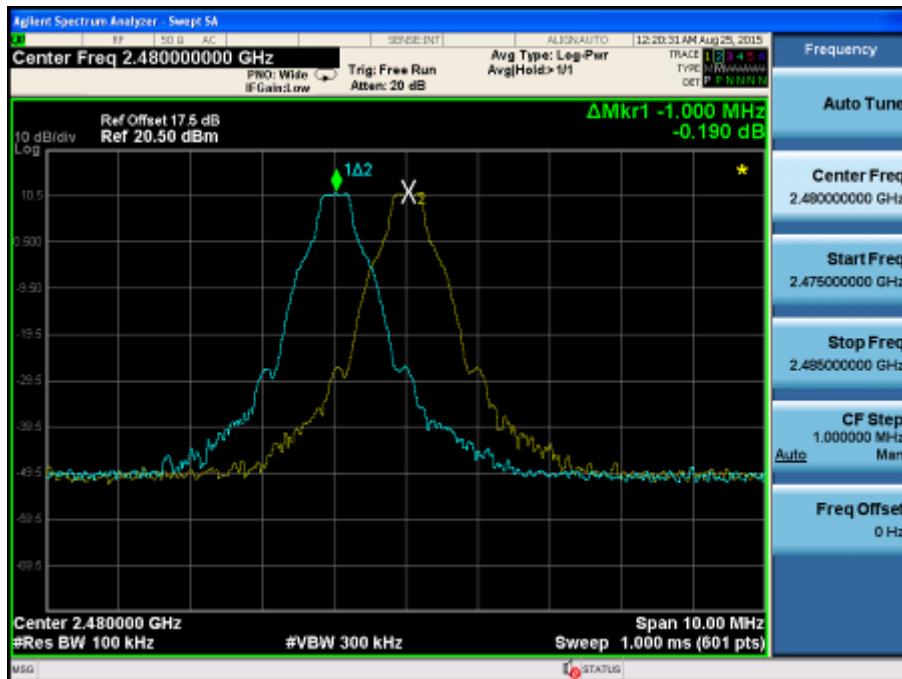

Product	:	Zipp
Test Item	:	Carrier Frequency Separation
Test Site	:	TR-8
Test Mode	:	Mode 2: Transmitter-2Mbps (Pi/4 DQPSK_DH5)

Channel No.	Frequency (MHz)	Carrier Frequency Separation (kHz)	Limit (kHz)	Result
00	2402	1000	>25 kHz or 2/3 of 20 dB BW	Pass
39	2441	1000	>25 kHz or 2/3 of 20 dB BW	Pass
78	2480	1000	>25 kHz or 2/3 of 20 dB BW	Pass

Channel 00 (2402MHz)

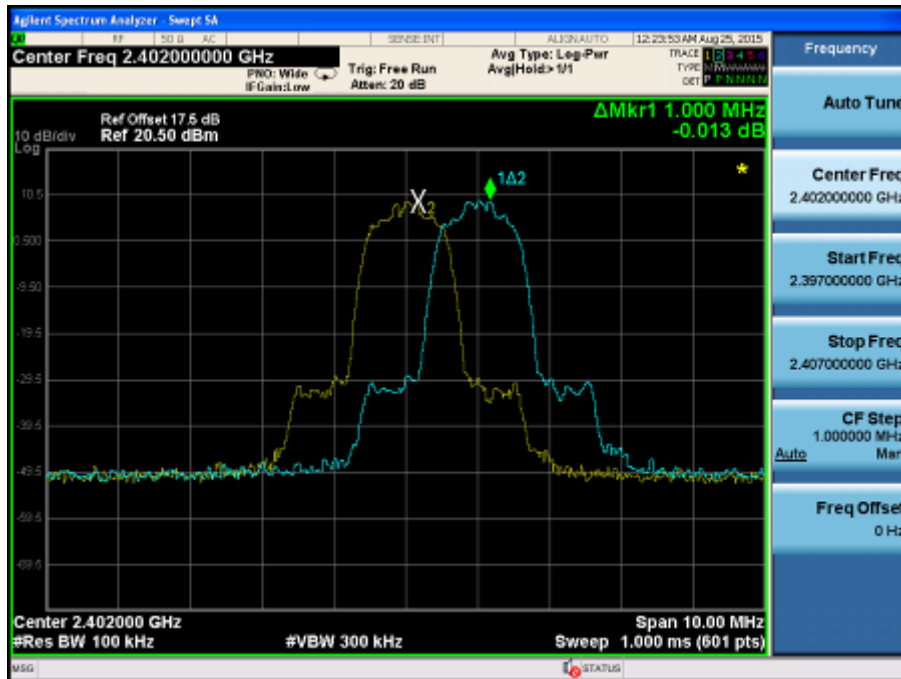

Channel 39 (2441MHz)

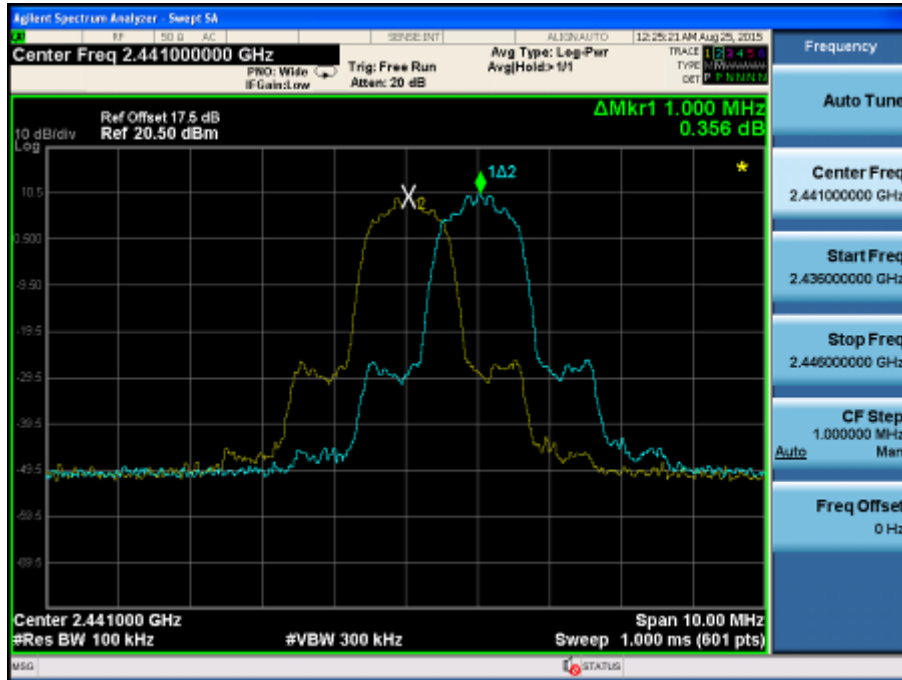

Channel 78 (2480MHz)

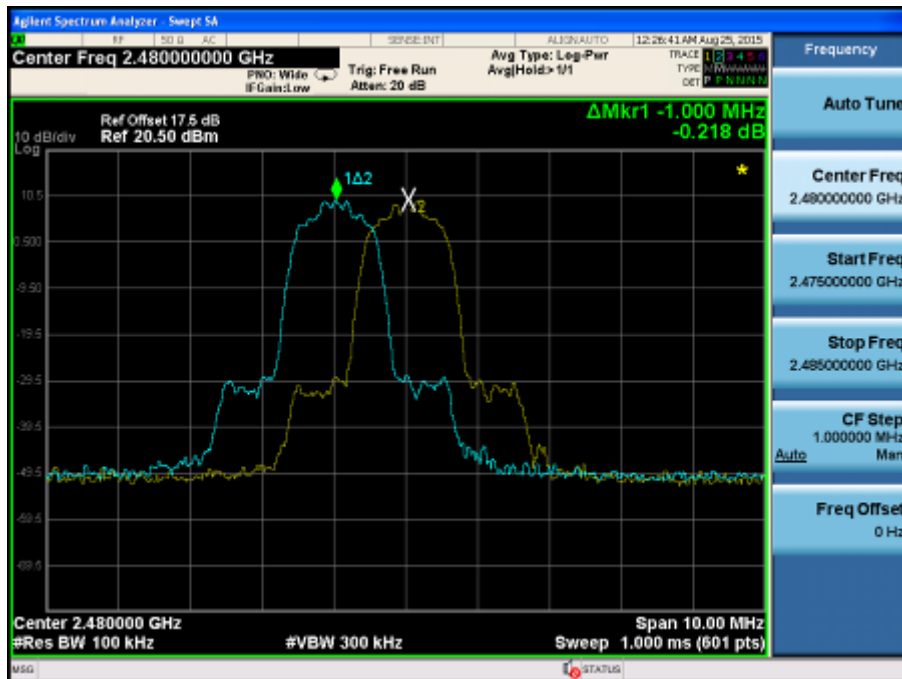

Product	:	Zipp
Test Item	:	Carrier Frequency Separation
Test Site	:	TR-8
Test Mode	:	Mode 3: Transmitter-3Mbps (8DPSK_DH5)

Channel No.	Frequency (MHz)	Carrier Frequency Separation (kHz)	Limit (kHz)	Result
00	2402	1000	>25 kHz or 2/3 of 20 dB BW	Pass
39	2441	1000	>25 kHz or 2/3 of 20 dB BW	Pass
78	2480	1000	>25 kHz or 2/3 of 20 dB BW	Pass

Channel 00 (2402MHz)

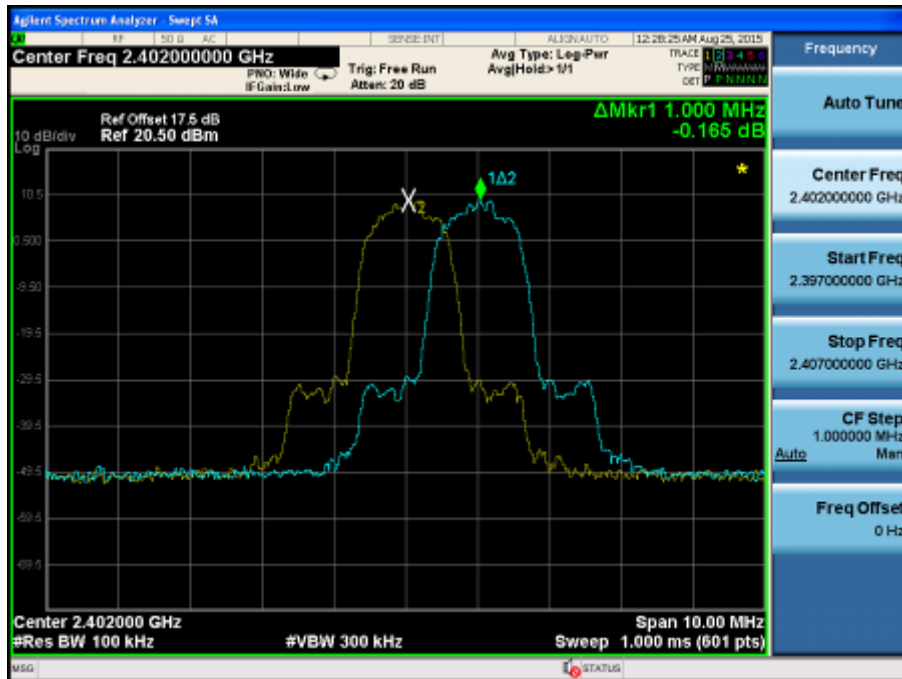

Channel 39 (2441MHz)

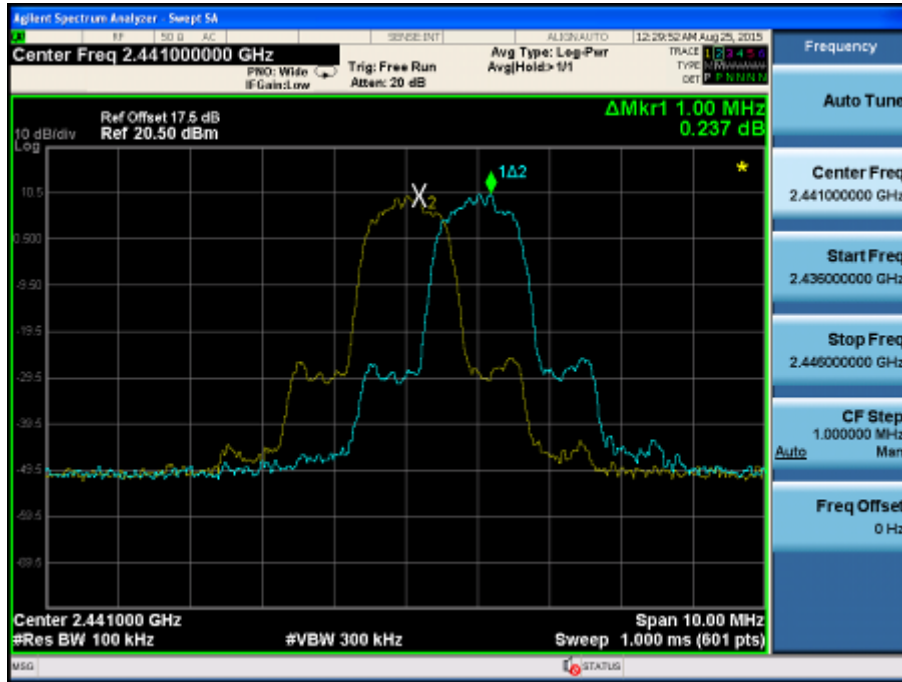

Channel 78 (2480MHz)

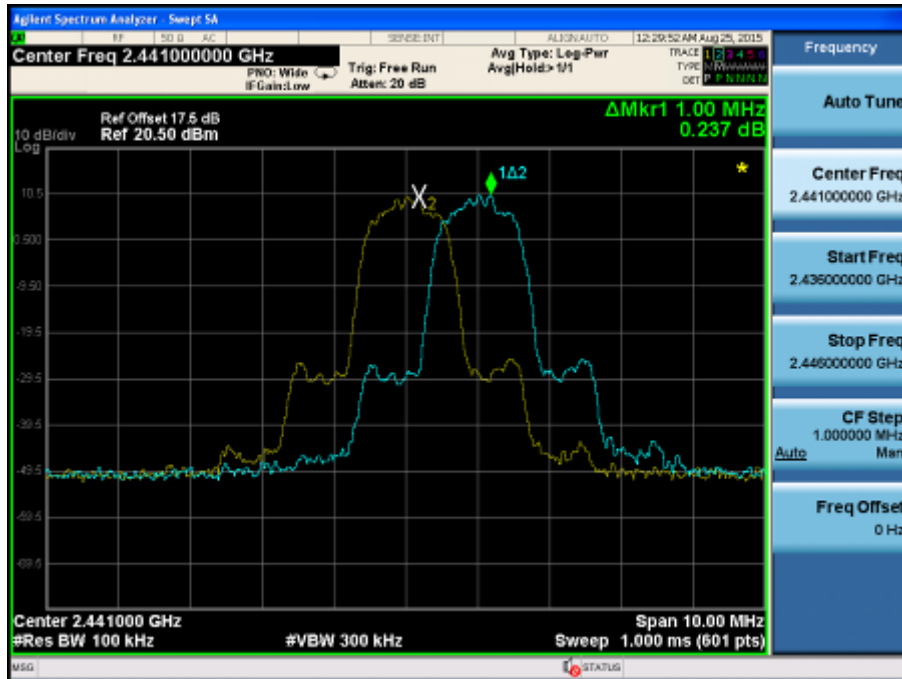

7. Number of Hopping Frequencies

7.1. Test Equipment

Number of Hopping Frequencies / TR-8

Instrument	Manufacturer	Type No.	Serial No.	Cal. Due Date
Spectrum Analyzer	Agilent	E4446A	MY45300103	2016.01.07
Temperature/Humidity Meter	Zhicheng	ZC1-2	TR8-TH	2016.04.09

Note: All equipments are calibrated with traceable calibrations. Each calibration is traceable to the national or international standards.

7.2. Test Setup

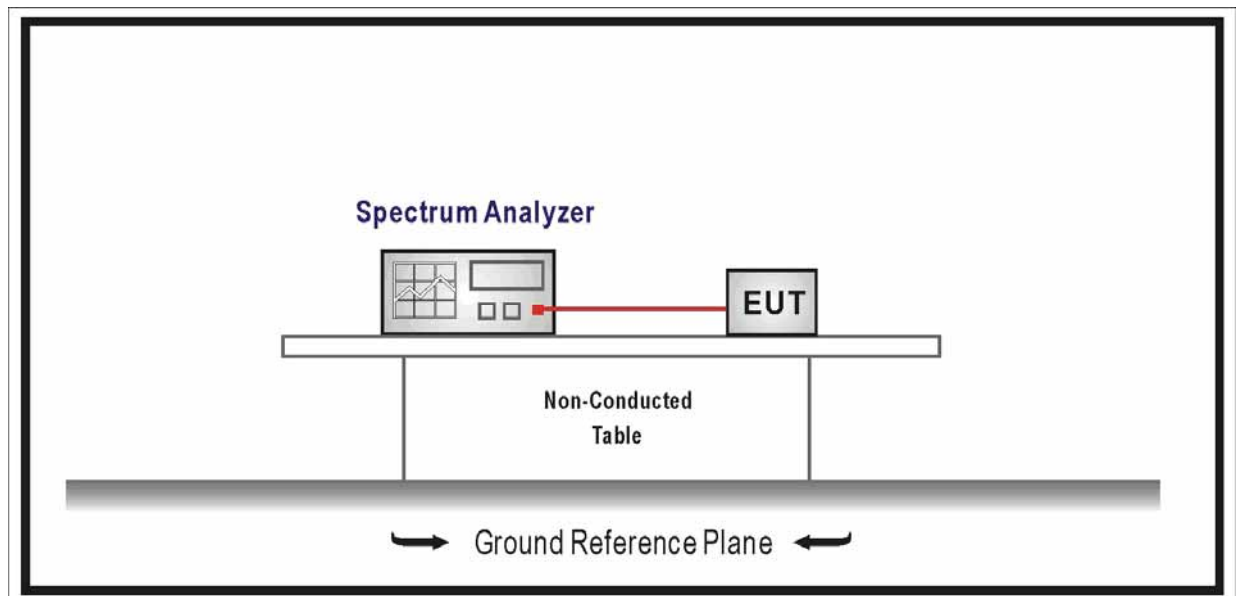

7.3. Limit

- For frequency hopping systems operating in the 2400-2483.5 MHz band shall use at least 15 hopping frequencies.
- For frequency hopping systems operating in 902-928 MHz band shall use at least 50 hopping frequencies.
- For frequency hopping systems operating in the 5725-5850 MHz band shall use at least 75 hopping frequencies.

7.4. Test Procedure

According to ANSI C63.10: 2013& ANSI C63.4: 2014

The EUT must have its hopping function enabled. Use the following spectrum analyzer settings:

Span = the frequency band of operation

RBW \cong 1% of the span

VBW \cong RBW

Sweep = auto

Detector function = peak

Trace = max hold

Allow the trace to stabilize. It may prove necessary to bread the span up to sections, in order to clearly show all of the hopping frequencies.

7.5. Uncertainty

The measurement uncertainty is defined as ± 1 kHz

7.6. Test Result

Product	:	Zipp
Test Item	:	Number of Hopping Frequencies
Test Site	:	TR-8
Test Mode	:	Mode 1: Transmitter-1Mbps (GFSK_DH5)

Frequency Band (MHz)	Number of Hopping Frequencies	Limit	Result
2400 - 2483.5	79	>15	Pass

2402 - 2421 MHz

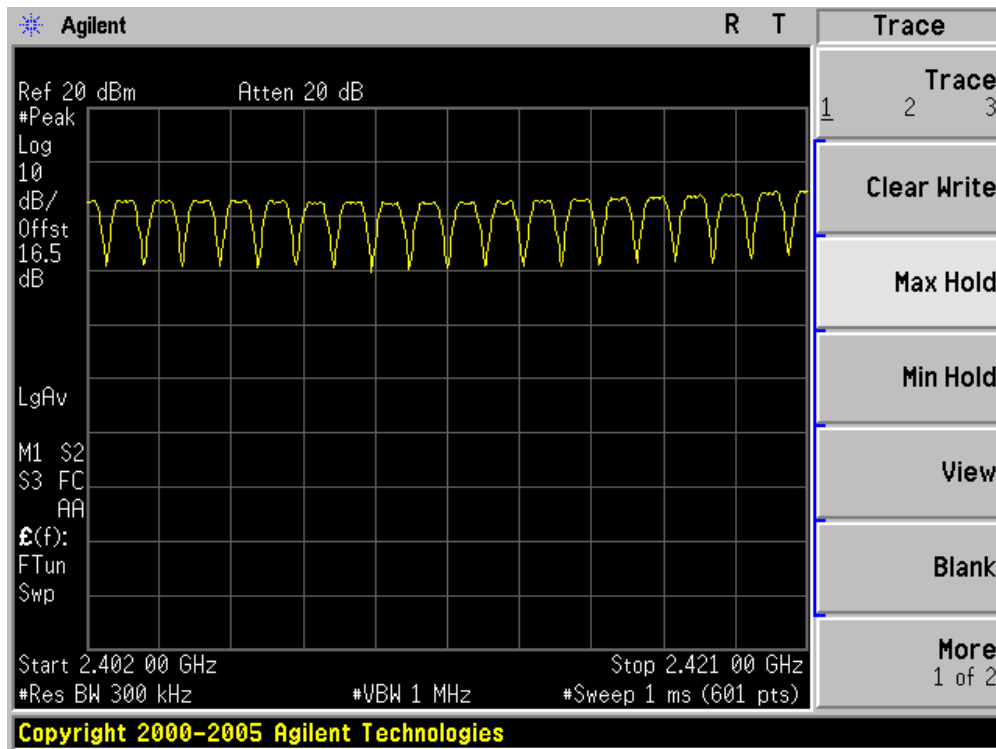

2422 - 2441 MHz

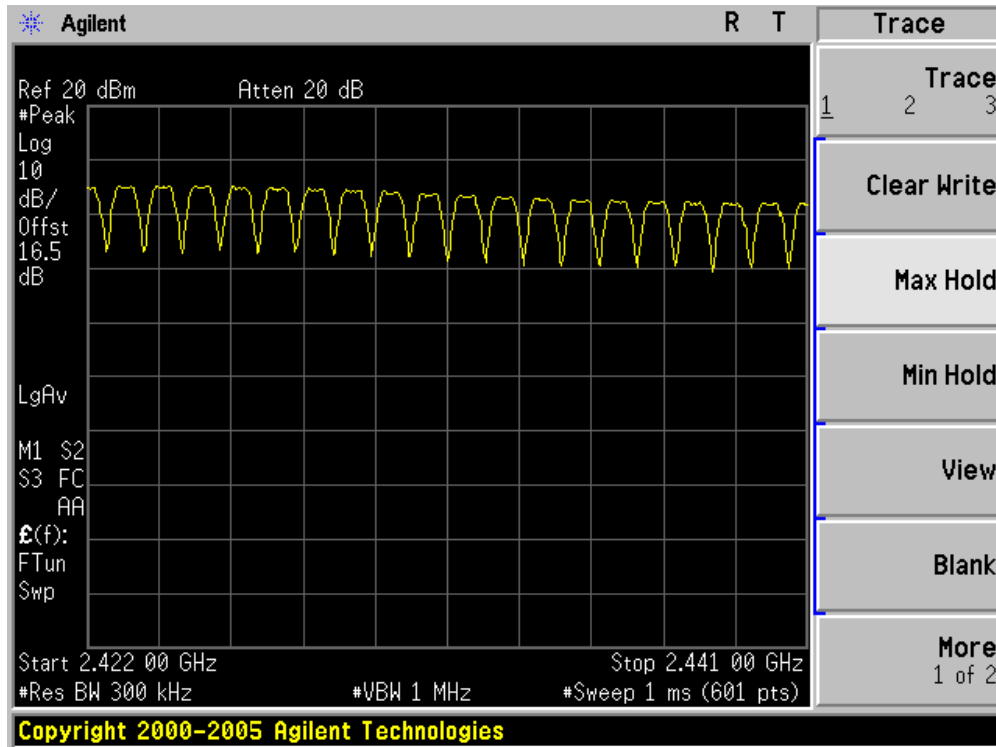

2442 - 2461 MHz

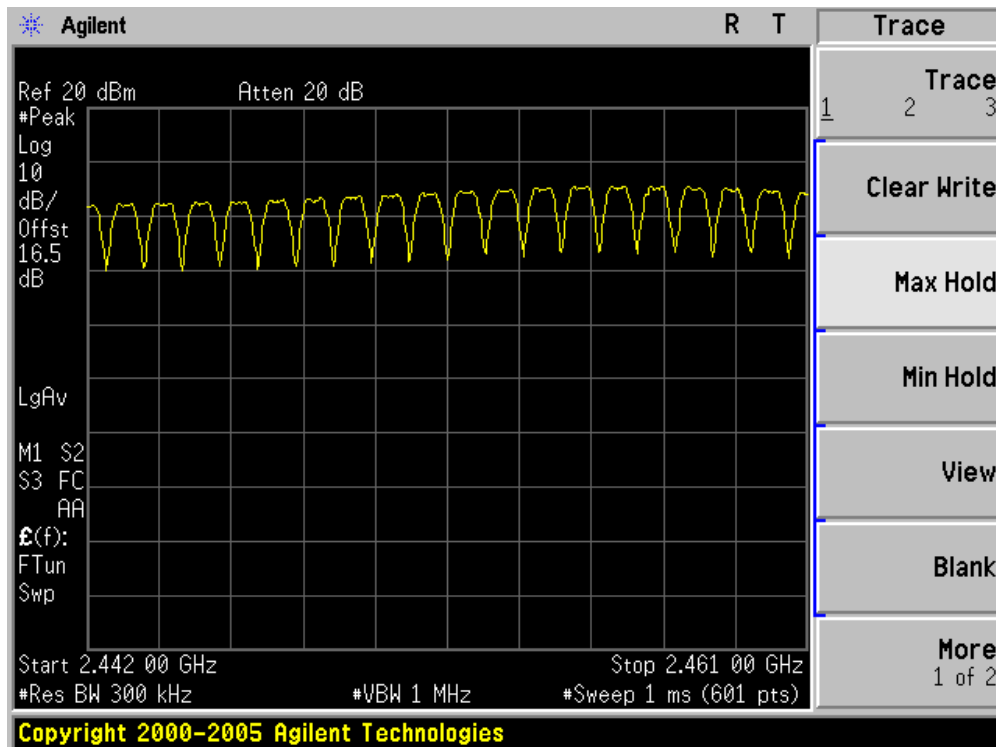

2462 - 2480 MHz

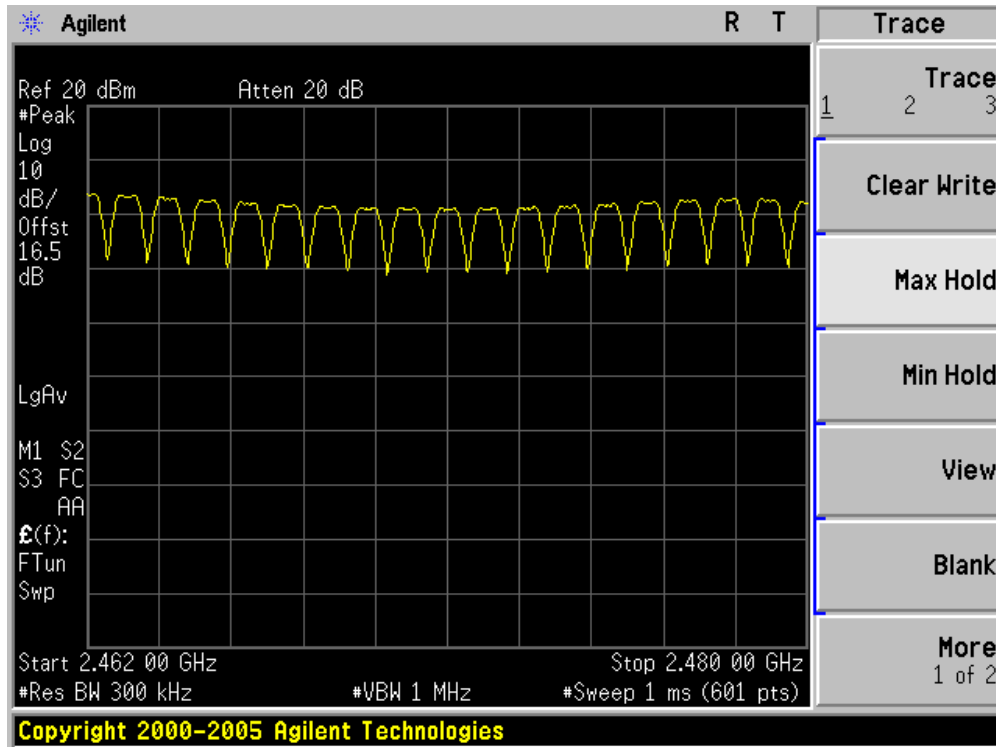

Product	:	Zipp
Test Item	:	Number of Hopping Frequencies
Test Site	:	TR-8
Test Mode	:	Mode 2: Transmitter-2Mbps (Pi/4 DQPSK_DH5)

Frequency Band (MHz)	Number of Hopping Frequencies	Limit	Result
2400 - 2483.5	79	>15	Pass

2402 - 2421 MHz

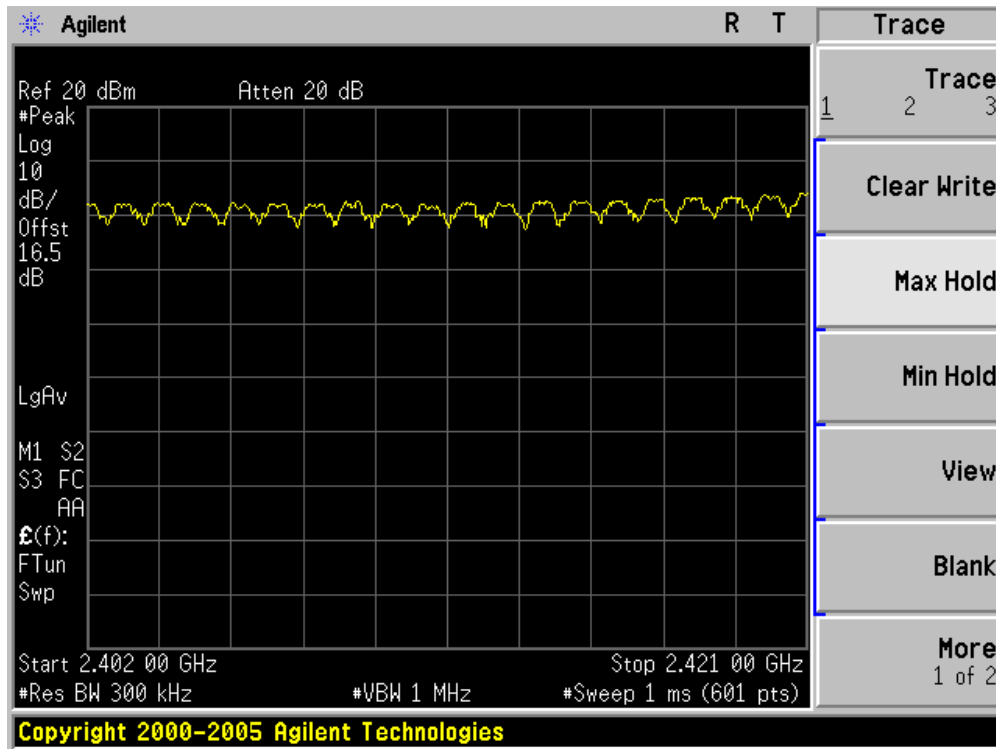

2422 - 2441 MHz

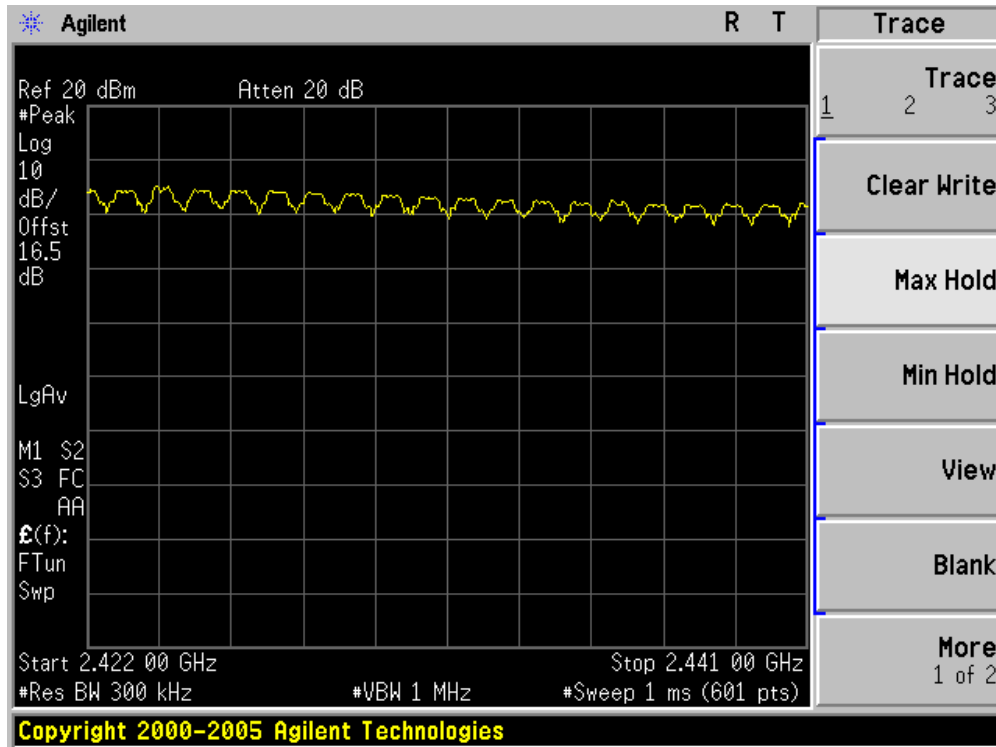

2442 - 2461 MHz

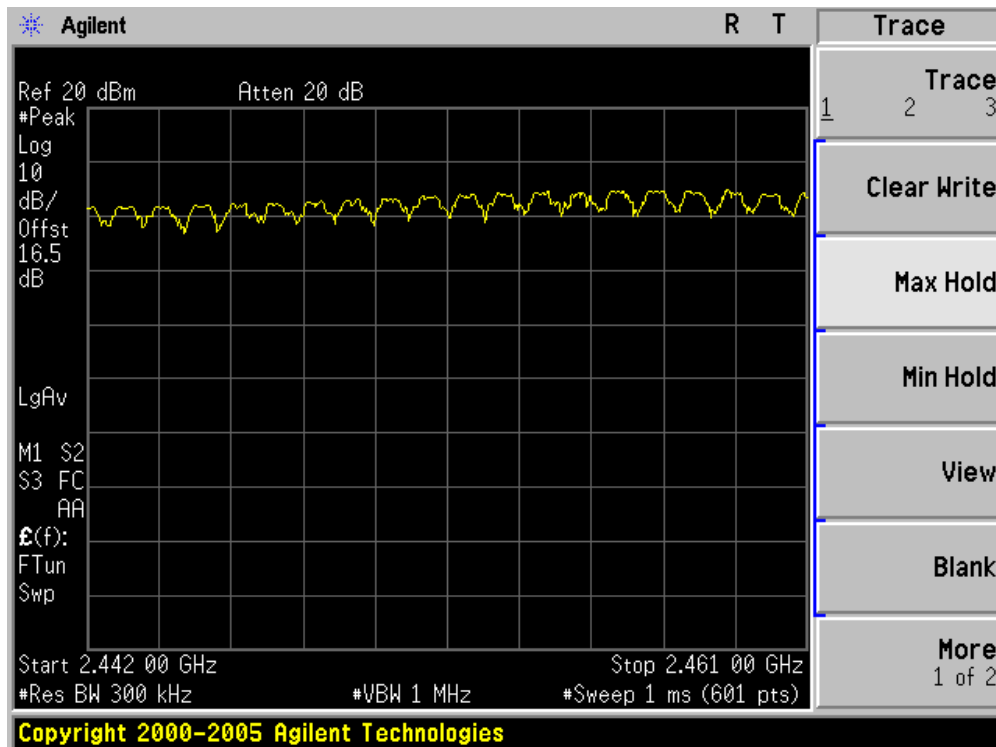

2462 - 2480 MHz

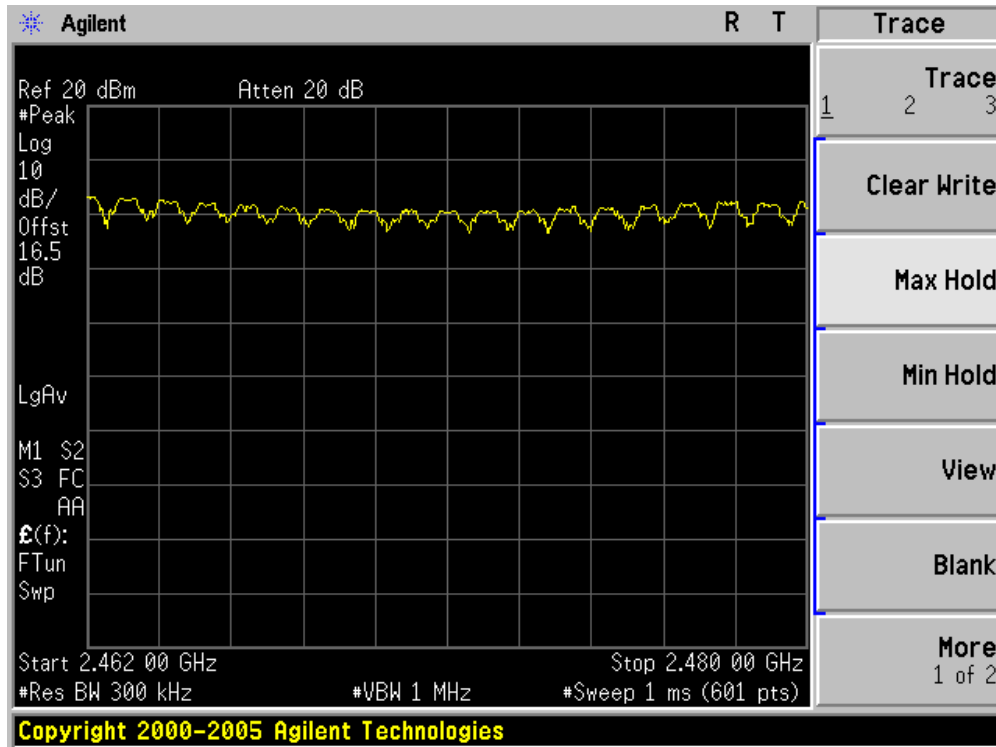

Product	:	Zipp
Test Item	:	Number of Hopping Frequencies
Test Site	:	TR-8
Test Mode	:	Mode 3: Transmitter-3Mbps (8DPSK_DH5)

Frequency Band (MHz)	Number of Hopping Frequencies	Limit	Result
2400 - 2483.5	79	>15	Pass

2402 - 2421 MHz

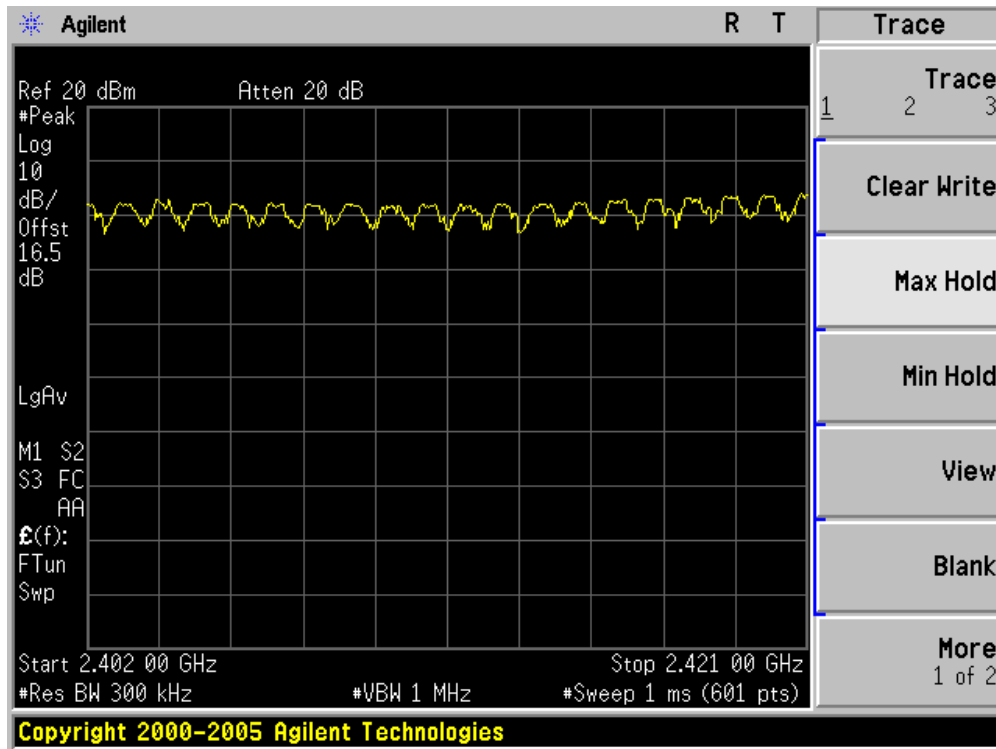

2422 - 2441 MHz

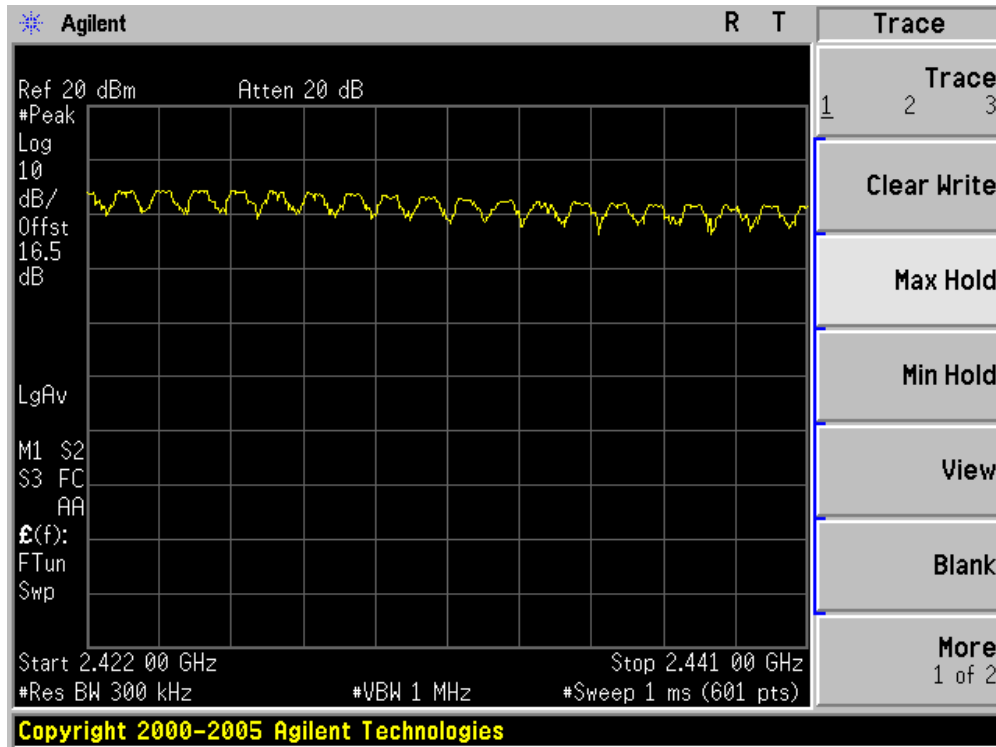

2442 - 2461 MHz

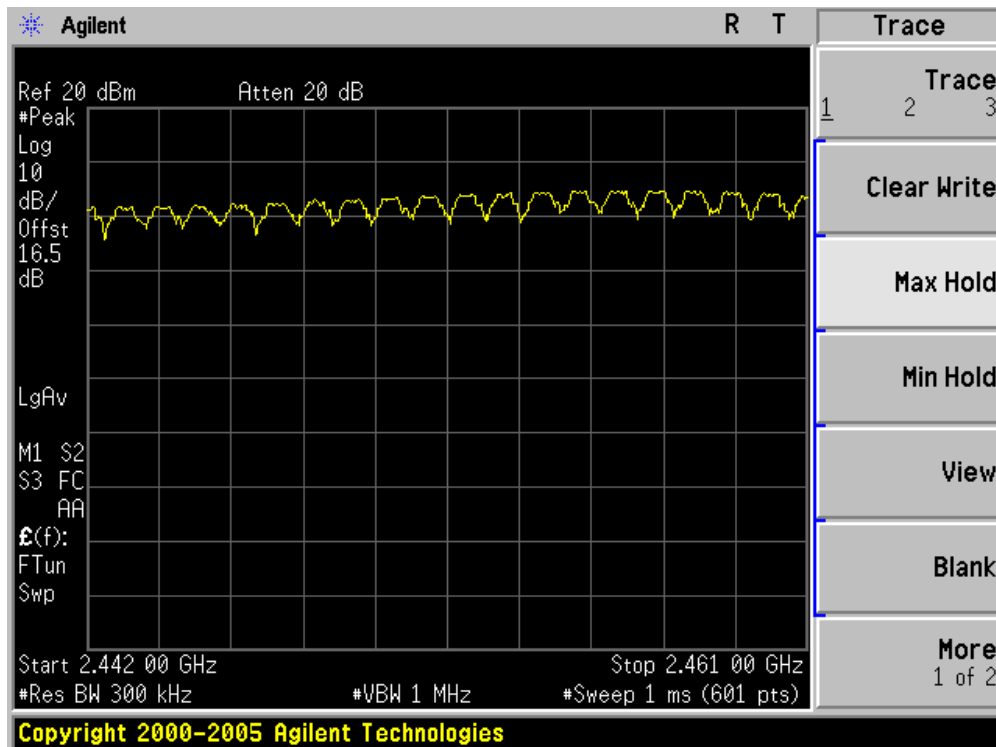

2462 - 2480 MHz

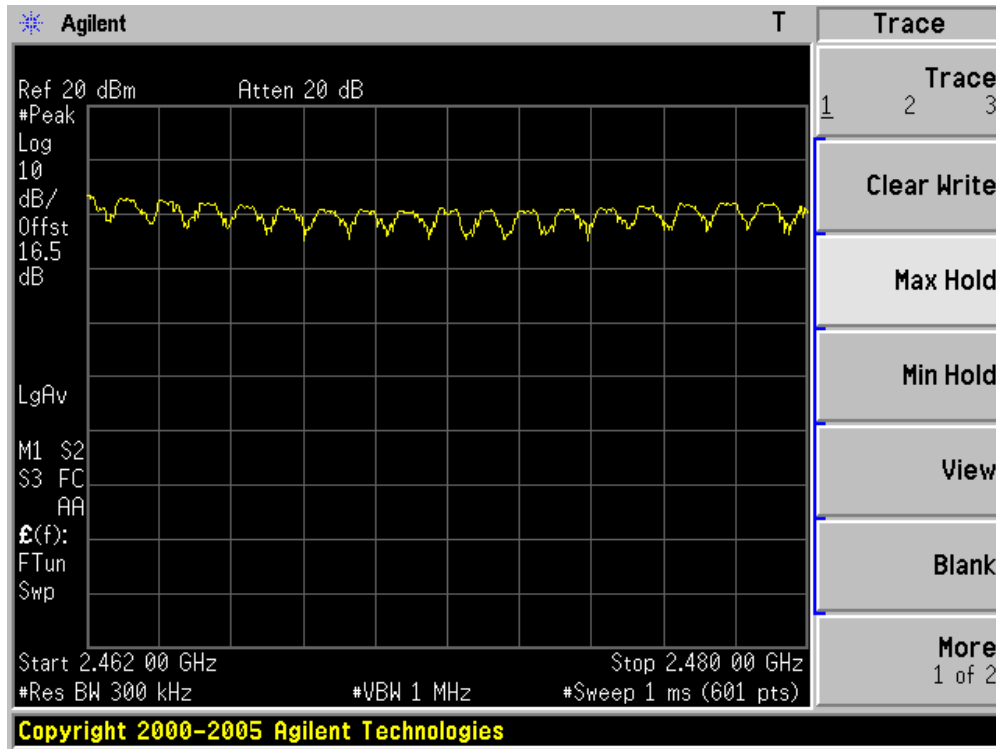

8. Time of Occupancy (Dwell Time)

8.1. Test Equipment

Time of Occupancy (Dwell Time) / TR-8

Instrument	Manufacturer	Type No.	Serial No.	Cal. Due Date
Spectrum Analyzer	Agilent	N9010A	MY48030494	2016.03.10
Temperature/Humidity Meter	Zhicheng	ZC1-2	TR8-TH	2016.04.09

Note: All equipments are calibrated with traceable calibrations. Each calibration is traceable to the national or international standards.

8.2. Test Setup

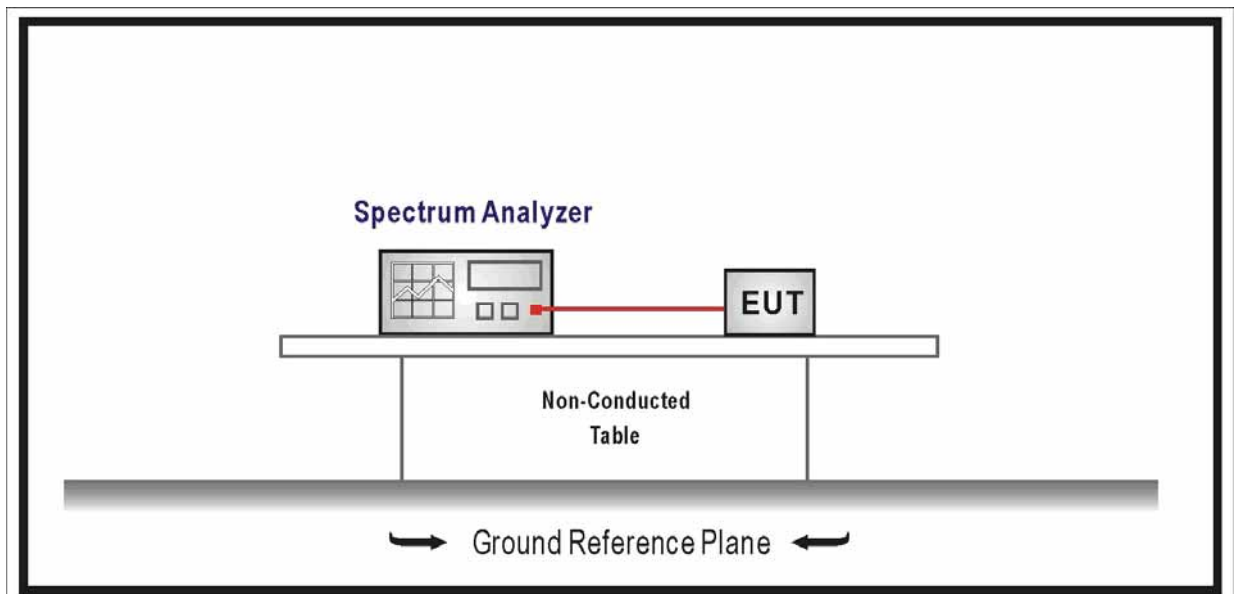

8.3. Limit

- For frequency hopping systems operating in the 902-928 MHz band: if the 20 dB bandwidth of the hopping channel is less than 250 kHz, the system shall use at least 50 hopping frequencies and the average time of occupancy on any frequency shall not be greater than 0.4 seconds within a 20 second period; If the 20 dB bandwidth of the hopping channel is 250 kHz or greater, the system shall use at least 25 hopping frequencies and the average time of occupancy on any frequency shall not be greater than 0.4 seconds within a 10 second period. The maximum allowed 20 dB bandwidth of the hopping channel is 500 kHz.
- Frequency hopping systems operating in the 5725-5850 MHz band shall use at least 75

hopping frequencies. The maximum 20 dB bandwidth of the hopping channel is 1 MHz. The average time of occupancy on any frequency shall not be greater than 0.4 seconds within a 30 second period.

- Frequency hopping systems in the 2400-2483.5 MHz band shall use at least 15 channels. The average time of occupancy on any channel shall not be greater than 0.4 seconds within a period of 0.4 seconds multiplied by the number of hopping channels employed. Frequency hopping systems may avoid or suppress transmissions on a particular hopping frequency provided that a minimum of 15 channels are used.

8.4. Test Procedure

According to ANSI C63.10: 2013& ANSI C63.4: 2014

The EUT must have its hopping function enabled. Use the following spectrum analyzer settings:

Span = zero span, centered on a hopping channel

RBW = 1MHz

VBW \cong RBW

Sweep = as necessary to capture the entire dwell time per hopping channel

Detector function = peak

Trace = max hold

If possible, use the marker-Zipp function to determine the dwell time. If this value varies with different modes of operation (e.g., data rate, modulation format, etc.), repeat this test for each variation.

8.5. Uncertainty

The measurement uncertainty is defined as ± 0.1 us

8.6. Test Result

Product	:	Zipp
Test Item	:	Time of Occupancy (Dwell Time)
Test Site	:	TR-8
Test Mode	:	Transmitter-1Mbps (GFSK_DH1)

Channel No.	Frequency (MHz)	Time of Occupancy (ms)	Limit (ms)	Result
39	2441	122.77	< 400	Pass

Test Time Period: $0.4 \times 79 = 31.6$ sec.

- 2441MHz, The Maximum Occupancy Time Within 31.6sec: $0.3766 \text{ms} \times 326 = 122.77 \text{msec}$

Channel 39 (2441MHz)-(DH1)

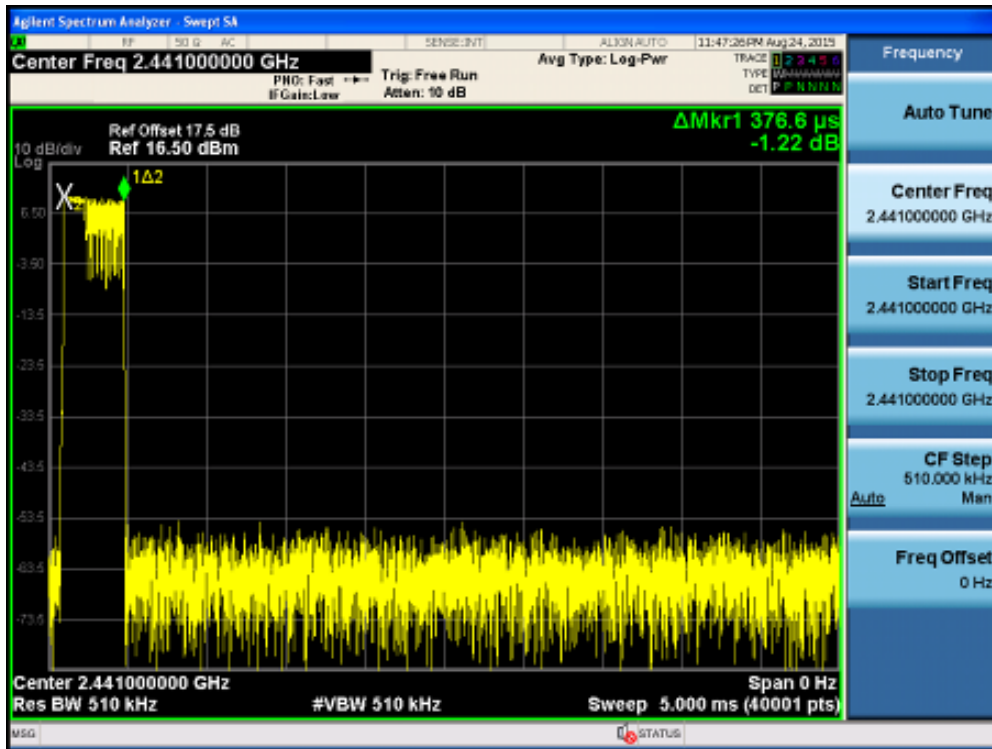

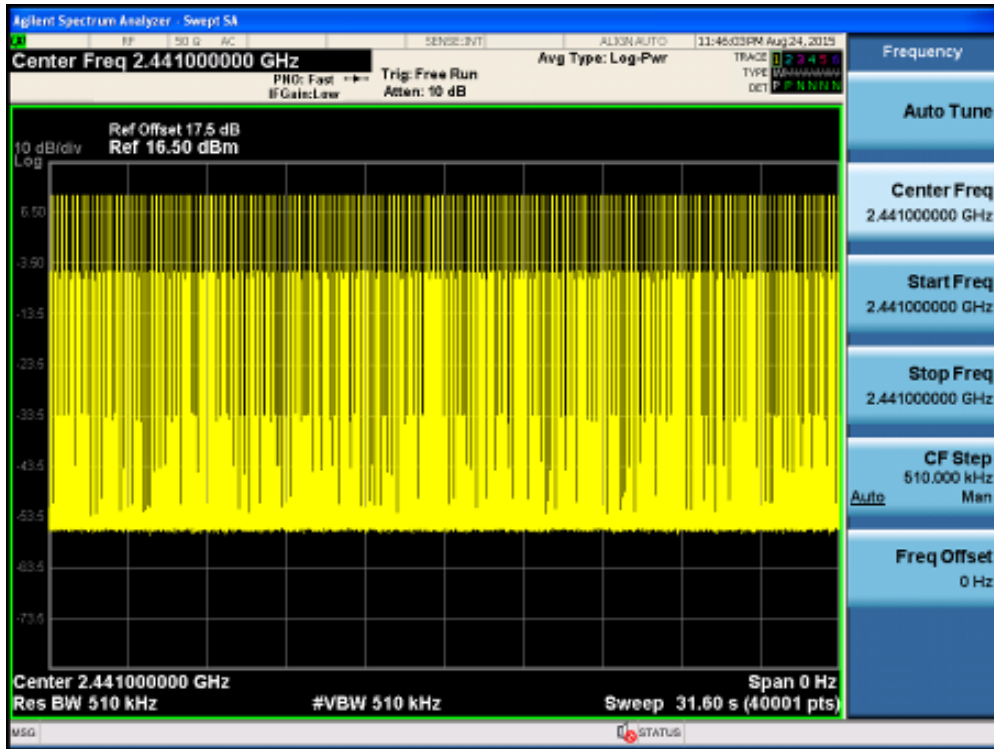

Product	:	Zipp
Test Item	:	Time of Occupancy (Dwell Time)
Test Site	:	TR-8
Test Mode	:	Transmitter-1Mbps (GFSK_DH3)

Channel No.	Frequency (MHz)	Time of Occupancy (ms)	Limit (ms)	Result
39	2441	268.46	< 400	Pass

Test Time Period: $0.4 \times 79 = 31.6$ sec.

- 2441MHz, The Maximum Occupancy Time Within 31.6sec: $1.627\text{ms} \times 165 = 268.46\text{msec}$

Channel 39 (2441MHz) - (DH3)

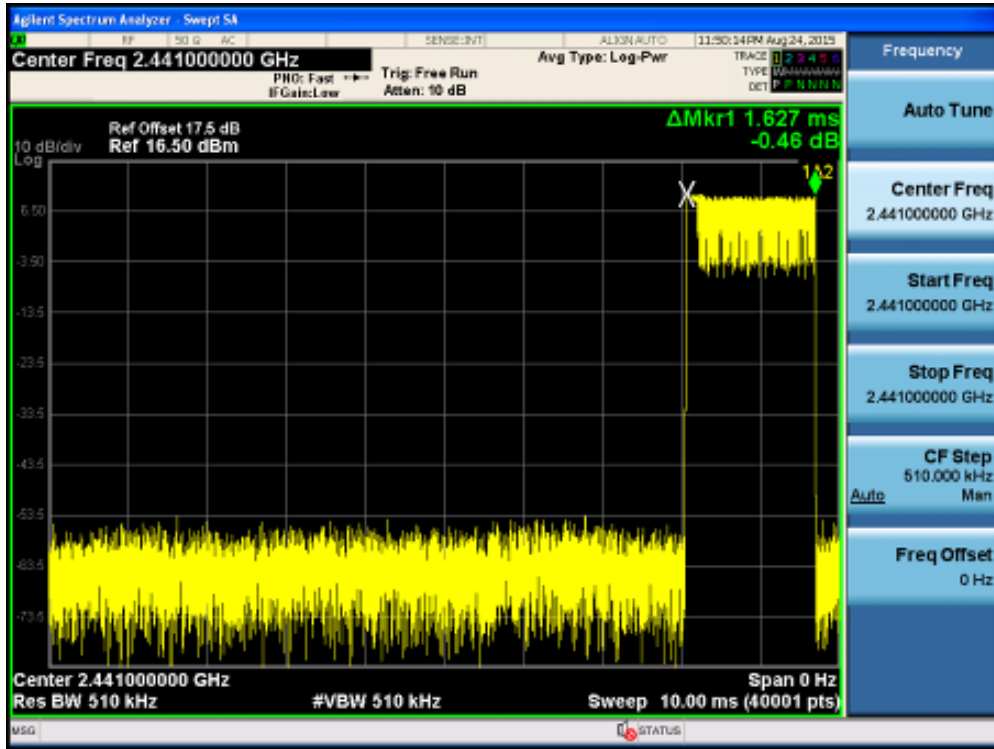

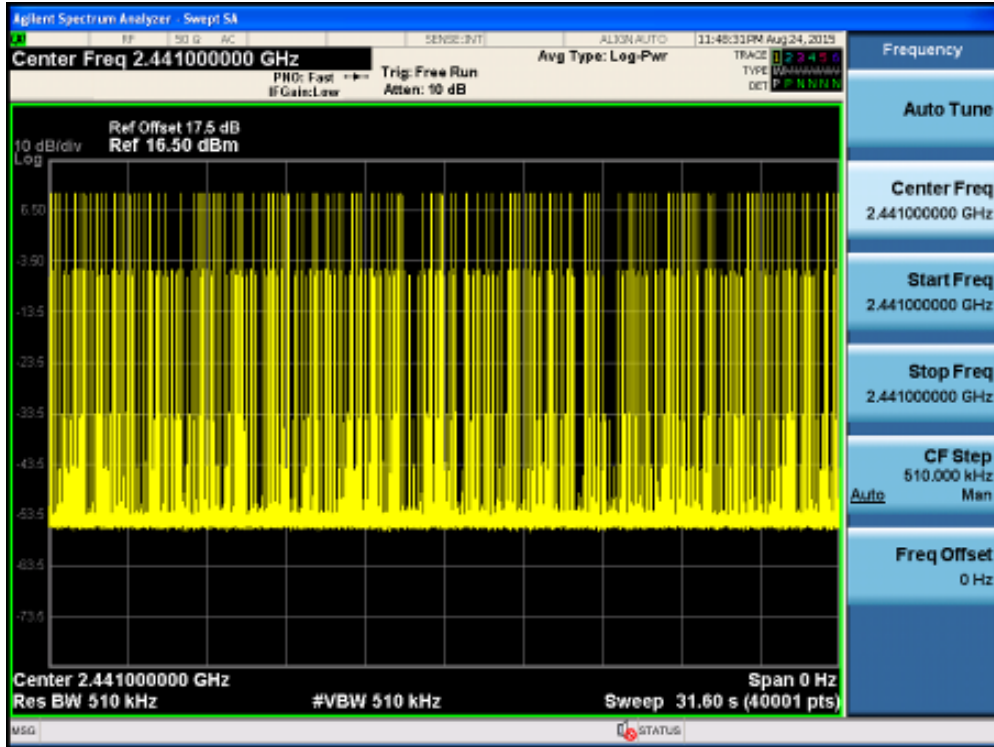

Product	: Zipp
Test Item	: Time of Occupancy (Dwell Time)
Test Site	: TR-8
Test Mode	: Transmitter-1Mbps (GFSK_DH5)

Channel No.	Frequency (MHz)	Time of Occupancy (ms)	Limit (ms)	Result
39	2441	310.93	< 400	Pass

Test Time Period: $0.4 \times 79 = 31.6$ sec.

- 2441MHz, The Maximum Occupancy Time Within 31.6sec: $2.879\text{ms} \times 108 = 310.93\text{msec}$

Channel 39 (2441MHz) - (DH5)

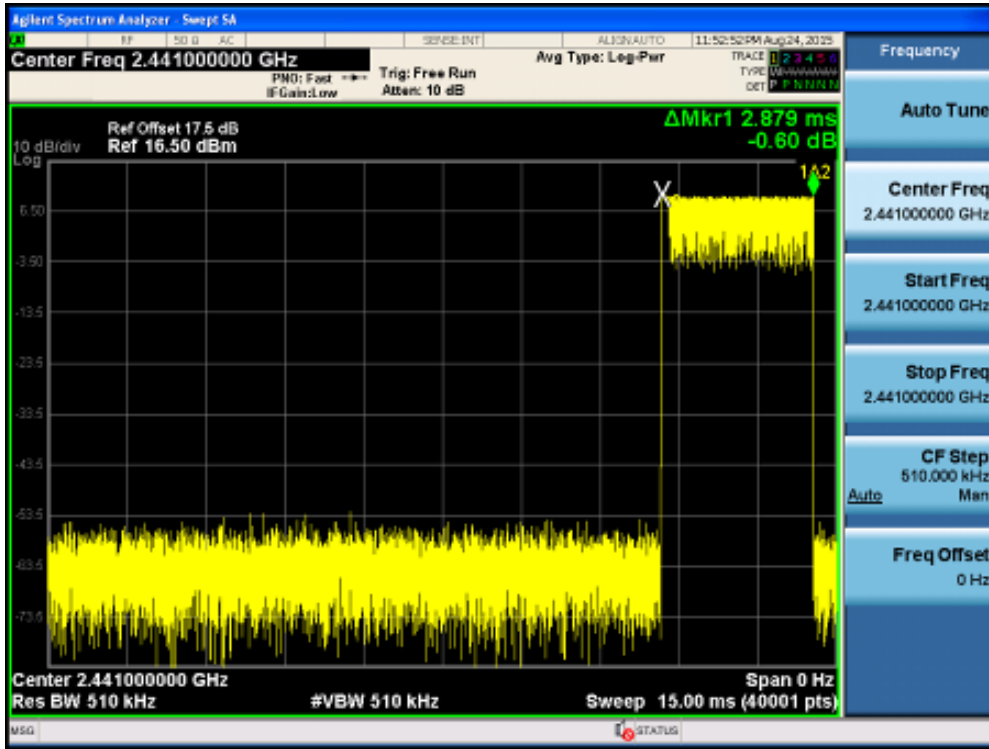

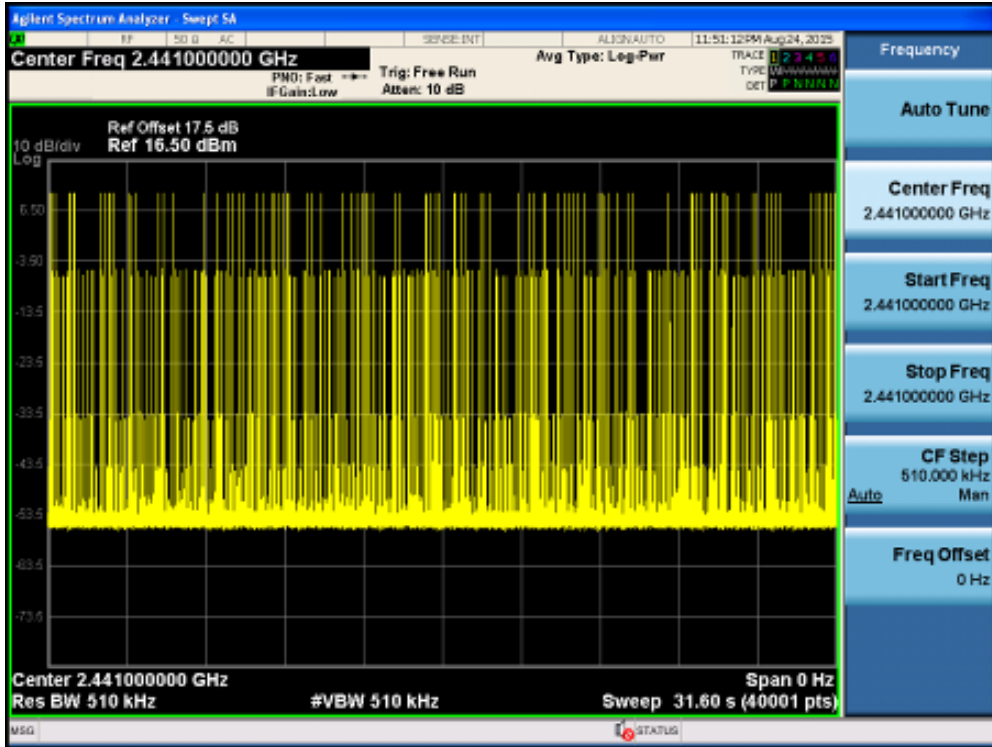

9. Peak Output Power

9.1. Test Equipment

Peak Output Power / TR-8

Instrument	Manufacturer	Type No.	Serial No.	Cal. Due Date
Spectrum Analyzer	Agilent	N9010A	MY48030494	2016.03.10
Temperature/Humidity Meter	Zhicheng	ZC1-2	TR8-TH	2016.04.09

Note: All equipments are calibrated with traceable calibrations. Each calibration is traceable to the national or international standards.

9.2. Test Setup

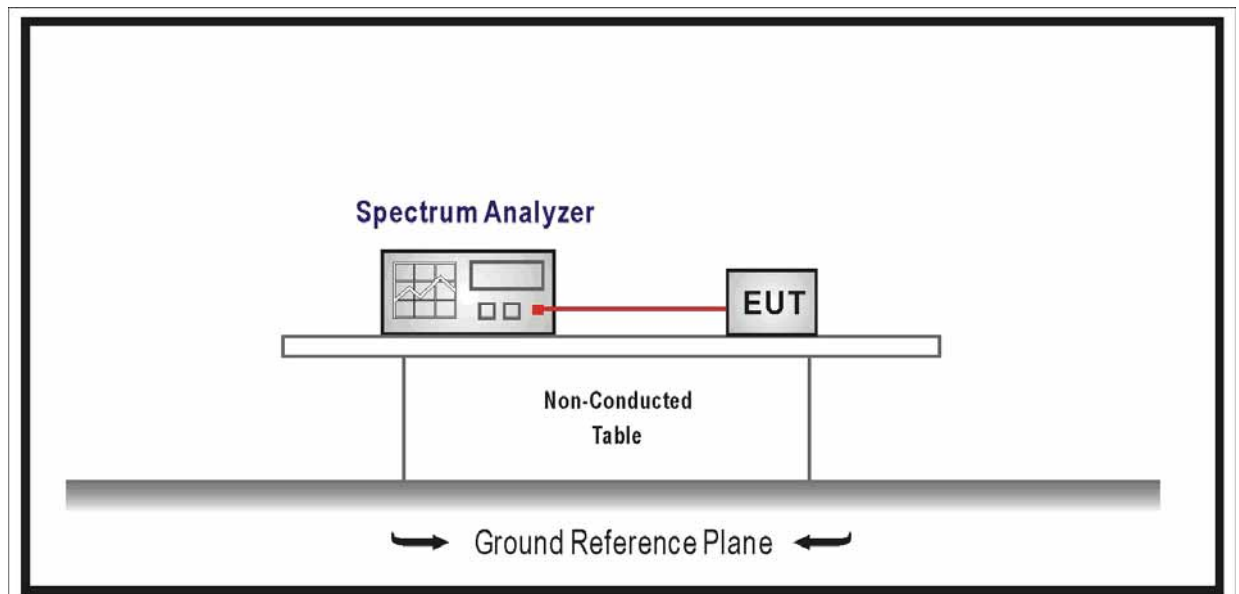

9.3. Limit

- For frequency hopping systems operating in the 2400-2483.5 MHz band employing at least 75 non-overlapping hopping channels, and all frequency hopping systems in the 5725-5850 MHz band: 1 watt. For all other frequency hopping systems in the 2400-2483.5 MHz band: 0.125 watts.
- For frequency hopping systems operating in the 902-928 MHz band: 1 watt for systems employing at least 50 hopping channels; and, 0.25 watts for systems employing less than 50 hopping channels, but at least 25 hopping channels.

Note: the conducted output power limit specified above is based on the use the antennas with

directional gains that do not exceed 6 dBi are used, the conducted output power from the intentional radiator shall be reduced below the stated values above, as appropriate, by the amount in dB that the directional gain of antenna exceeds 6 dBi.

9.4. Test Procedure

According to ANSI C63.10: 2013& ANSI C63.4: 2014

Use the following spectrum analyzer settings:

Span = approximately 5 times the 20dB bandwidth, centered on a hopping channel

RBW > the 20 dB bandwidth of the emission being measured.

VBW \cong RBW

Sweep = auto

Detector function = peak

Trace = max hold

Allow the trace to stabilize. Use the marker-to-peak function to set the marker to the peak of the emission. The indicated level is the peak output power (don't forget added the external attenuation and cable loss).

9.5. Uncertainty

The measurement uncertainty is defined as ± 1.0 dB

9.6. Test Result

Product	:	Zipp
Test Item	:	Power Output
Test Mode	:	Mode 1: Transmitter-1Mbps (GFSK_DH5)

Channel No.	Frequency (MHz)	Measurement Power Output (dBm)	Limit (dBm)	Result
0	2402	6.482	30.00	Pass
39	2441	6.715	30.00	Pass
78	2480	6.794	30.00	Pass

DH5 2402MHz



Product	: Zipp
Test Item	: Power Output
Test Mode	: Mode 2: Transmitter-2Mbps (Pi/4 DQPSK_DH5)

Channel No.	Frequency (MHz)	Measurement Power Output (dBm)	Limit (dBm)	Result
0	2402	5.388	30.00	Pass
39	2441	5.010	30.00	Pass
78	2480	4.968	30.00	Pass

2DH5 2402MHz

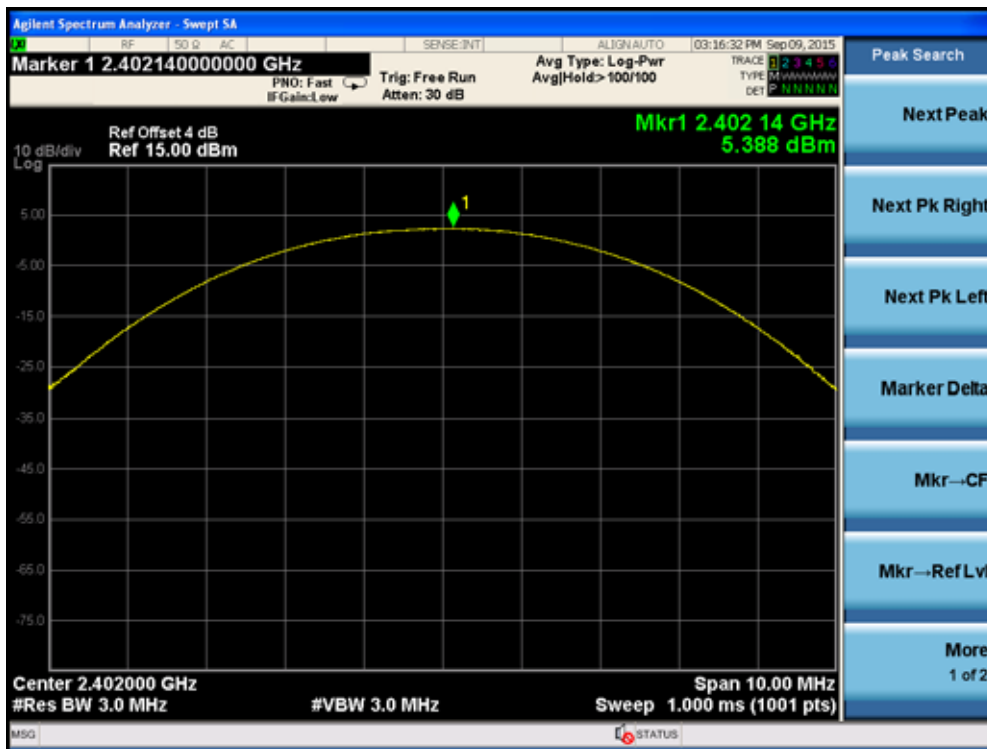

2DH5 2441MHz



2DH5 2480MHz

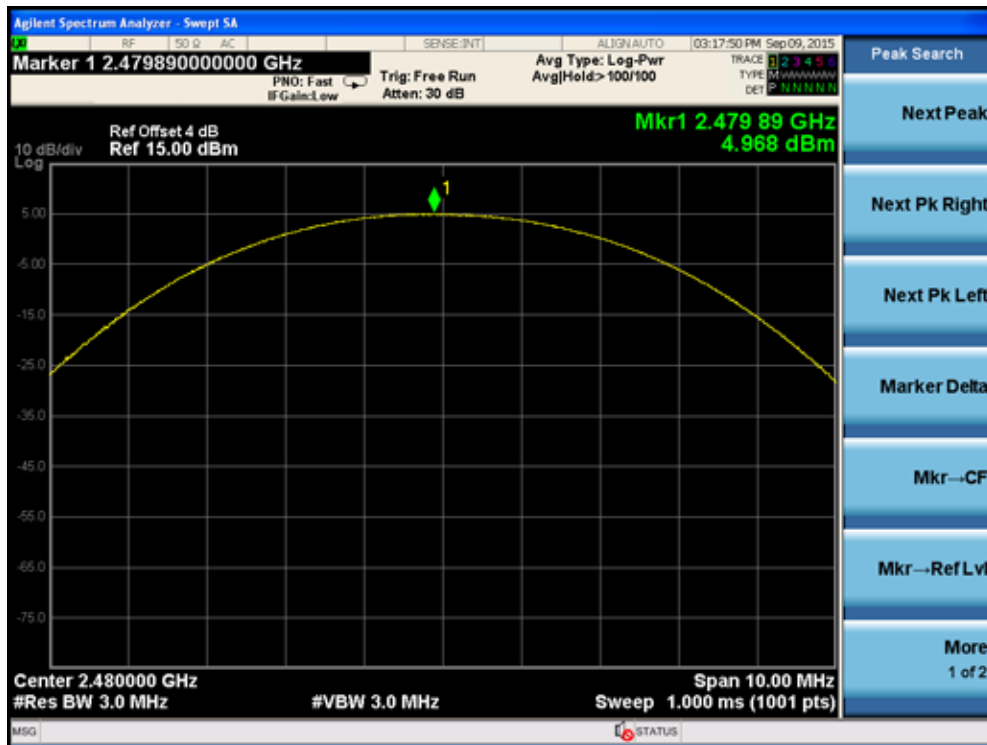

Product	: Zipp
Test Item	: Power Output
Test Mode	: Mode 3: Transmitter-3Mbps (8DPSK_DH5)

Channel No.	Frequency (MHz)	Measurement Power Output (dBm)	Limit (dBm)	Result
0	2402	5.652	30.00	Pass
39	2441	5.386	30.00	Pass
78	2480	5.360	30.00	Pass

3DH5 2402MHz

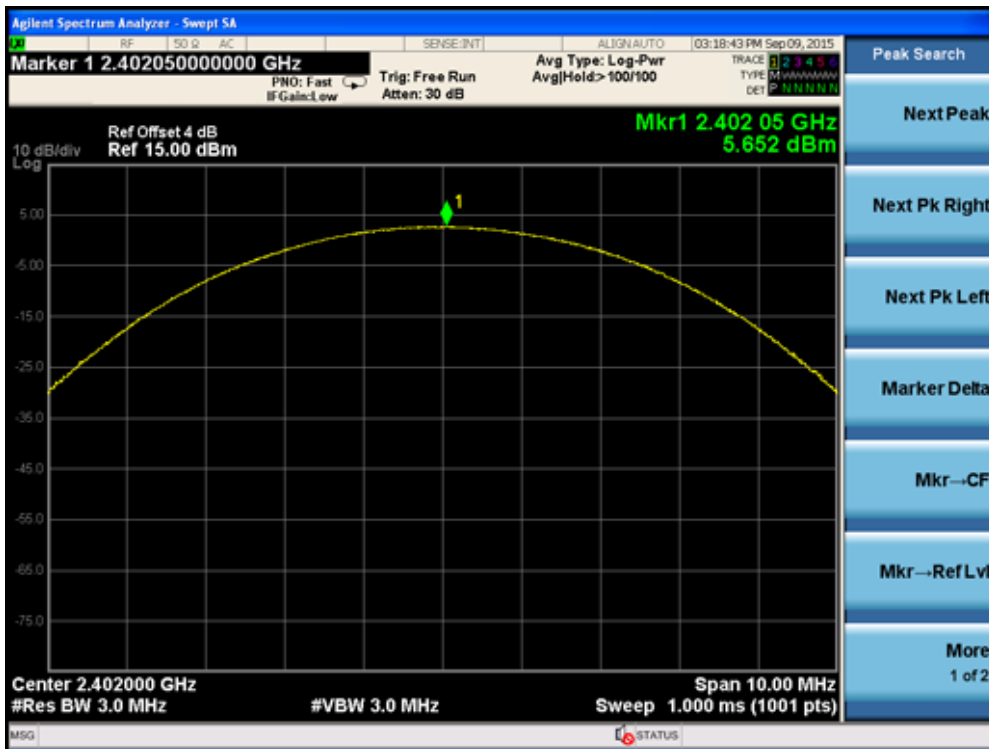

3DH5 2441MHz

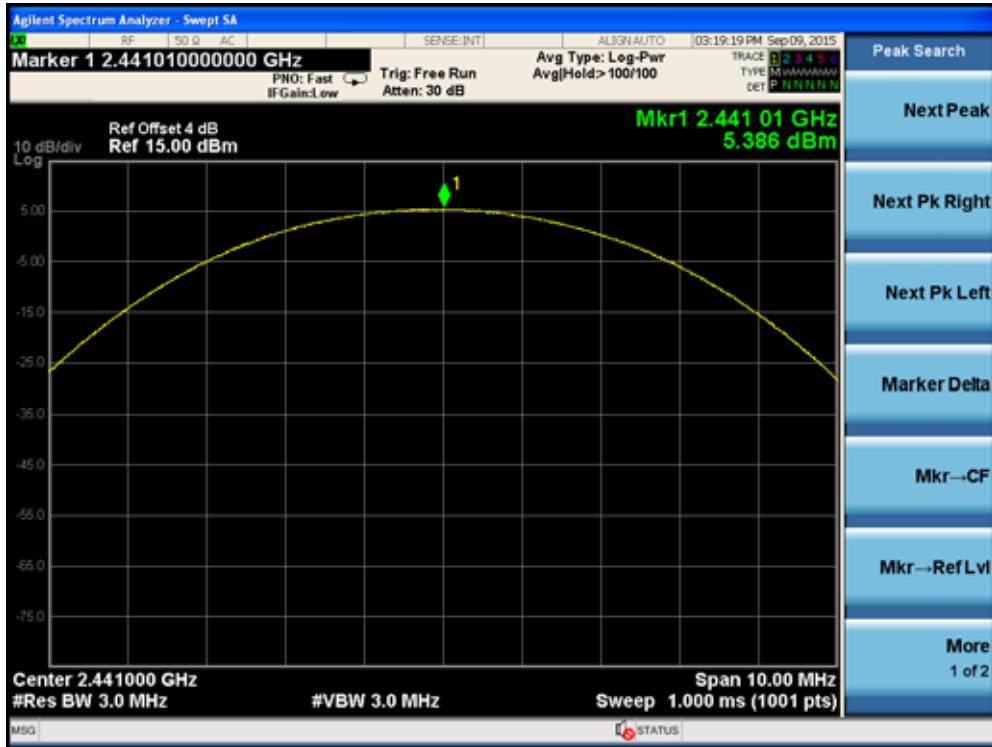

3DH5 2480MHz

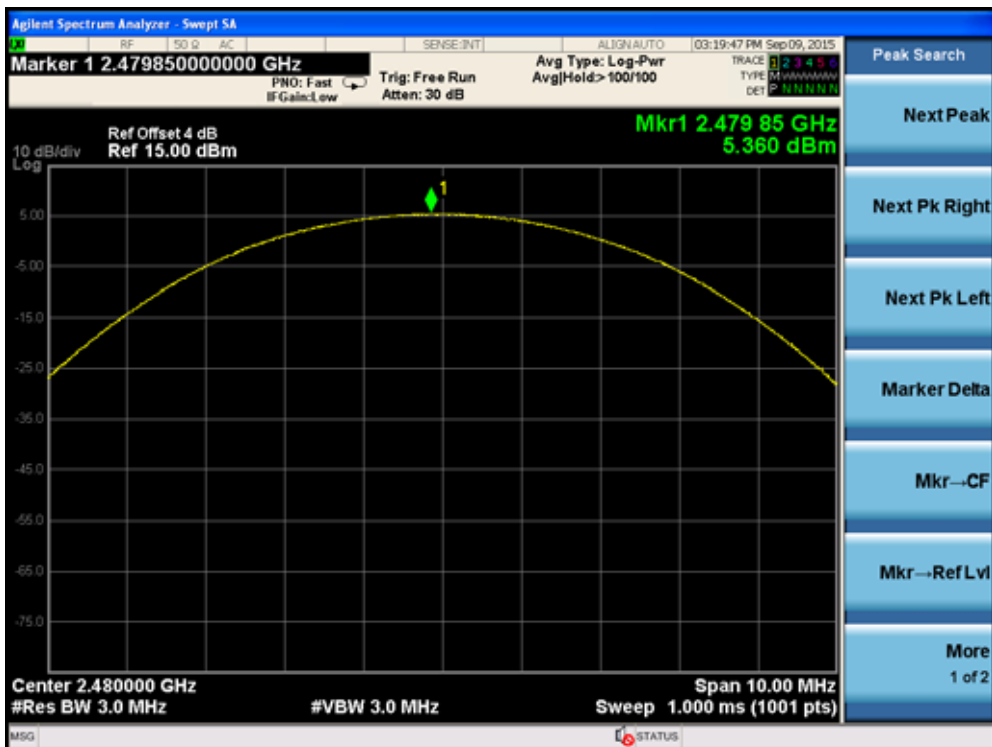

10. Band-edge Compliance of RF Conducted Emissions

10.1. Test Equipment

Band-edge Compliance of RF Conducted Emissions / TR-8

Instrument	Manufacturer	Type No.	Serial No.	Cal. Due Date
Spectrum Analyzer	Agilent	N9010A	MY48030494	2016.03.10
Temperature/Humidity Meter	Zhicheng	ZC1-2	TR8-TH	2016.04.09

Note: All equipments are calibrated with traceable calibrations. Each calibration is traceable to the national or international standards.

10.2. Test Setup

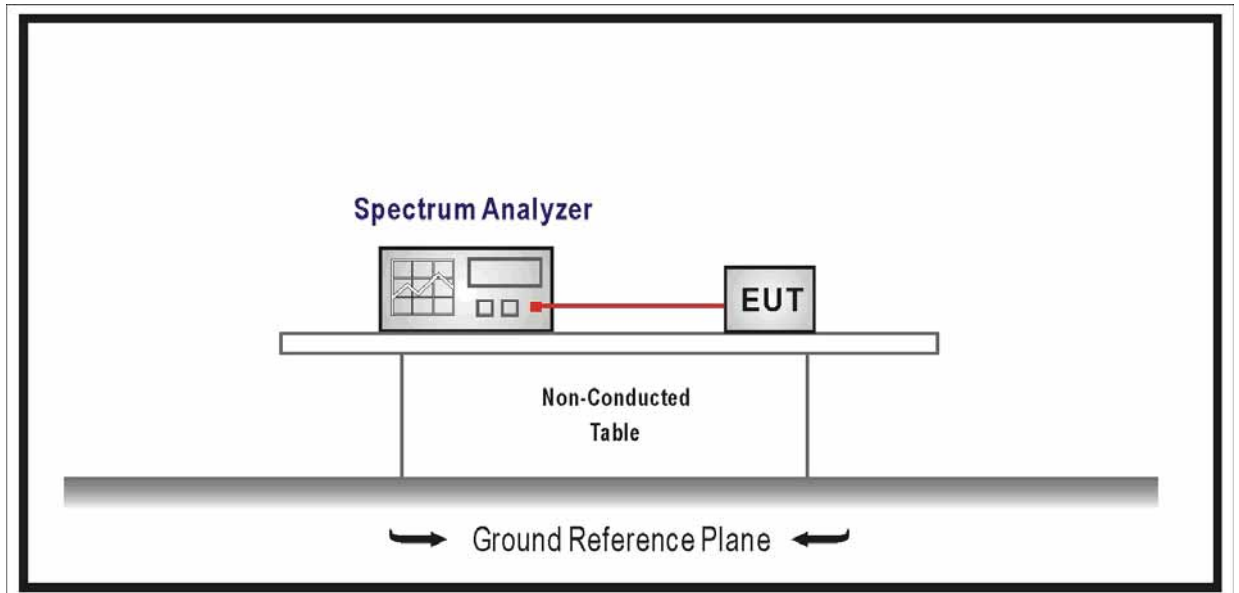

10.3. Limit

- Intentional radiators operating under the alternative provisions to the general emission limits as contained in 15.217 through 15.257 and in Subpart E of FCC part 15, must be designed to ensure that 20 dB bandwidth of the emission, or whatever bandwidth may otherwise be specified in the specific rule section under which the equipment operates, is contained within the frequency band designated in the rule section under which the equipment is operated.
- In any 100 kHz bandwidth outside the frequency band in which the spread spectrum or digitally modulated intentional radiator is operating, the radio frequency power that is produced by the intentional radiator shall be at least 20 dB below that in the 100 kHz

bandwidth within the band that contains the highest level of the desired power, based on either an RF conducted or a radiated measurement, provided the transmitter demonstrates compliance with the peak conducted or a radiated measurement, provided the transmitter demonstrates compliance with the peak conducted power limits. If the transmitter complies with the conducted power limits based on the use of RMS averaging over a time interval, the attenuation required under this paragraph shall be 30 dB instead of 20 dB. Attenuation below the general limits specified in Section 15.209(a) of FCC part 15 is not required.

10.4. Test Procedure

According to ANSI C63.10: 2013& ANSI C63.4: 2014

Use the following spectrum analyzer settings:

Span = wide enough to capture the peak level of the emission operating on the channel closest to the bandedge, as well as any modulation products which fall outside of the authorized band of operation.

RBW \cong 1% of the span

VBW \cong RBW

Sweep = auto

Detector function = peak

Trace = max hold

Allow the trace to stabilize. Set the marker on the emission at the bandedge, or on the highest modulation product outside of the band, if this level is greater than that at the bandedge.

Enable the marker-Zipp function, then use the marker-to-peak function to move the marker to the peak of the in-band emission. The marker-Zipp value now displayed must comply with the limit specified in this Section.

Now, using the same instrument settings, enable the hopping function of the EUT. Allow the trace to stabilize. Follow the same procedure listed above to determine if any spurious emissions caused by the hopping function also comply with the specified limit.

10.5. Uncertainty

The measurement uncertainty is defined as ± 1.0 dB

10.6. Test Result

Product	: Zipp
Test Item	: Band-edge Compliance of RF Conducted Emissions
Test Site	: TR-8
Test Mode	: Mode 1: Transmitter-1Mbps (GFSK_DH5)

Channel 00 (2402MHz)

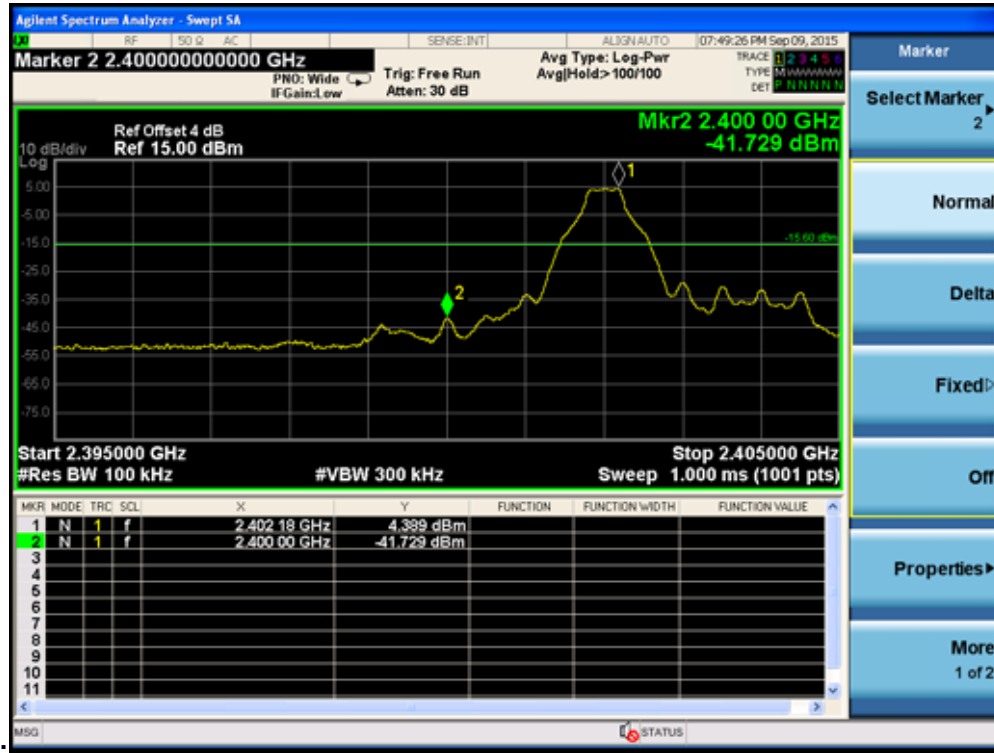

Channel 78 (2480MHz)

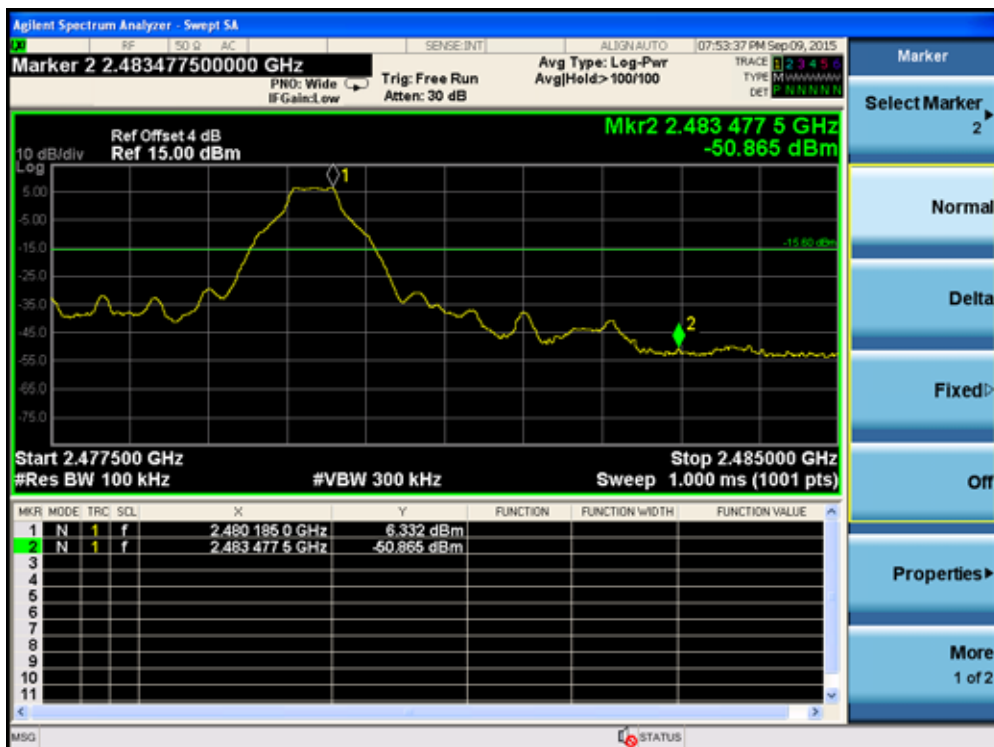

Product	: Zipp
Test Item	: Band-edge Compliance of RF Conducted Emissions
Test Site	: TR-8
Test Mode	: Mode 2: Transmitter-2Mbps (Pi/4 DQPSK_DH5)

Channel 00 (2402MHz)

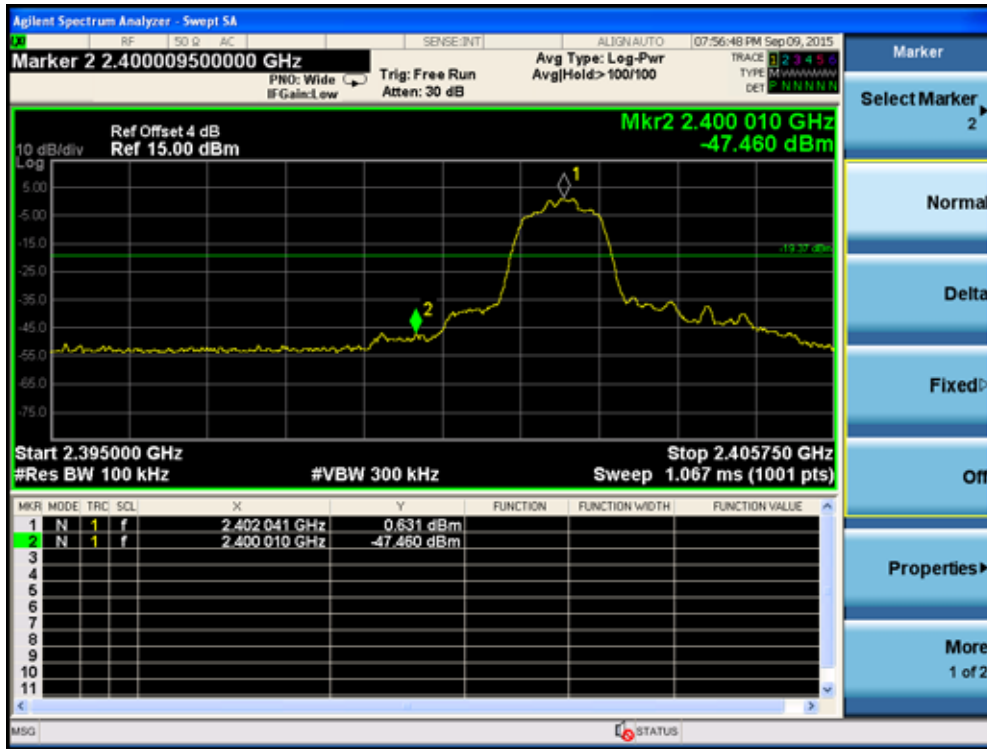

Channel 78 (2480MHz)

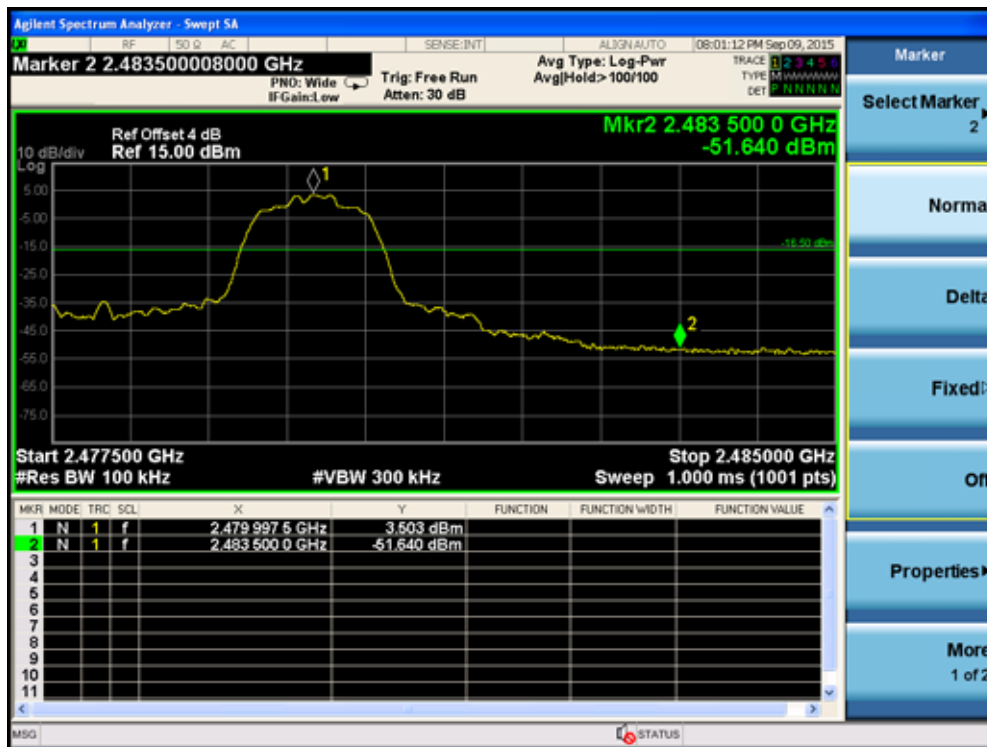

Product	: Zipp
Test Item	: Band-edge Compliance of RF Conducted Emissions
Test Site	: TR-8
Test Mode	: Mode 3: Transmitter-3Mbps (8DPSK_DH5)

Channel 00 (2402MHz)

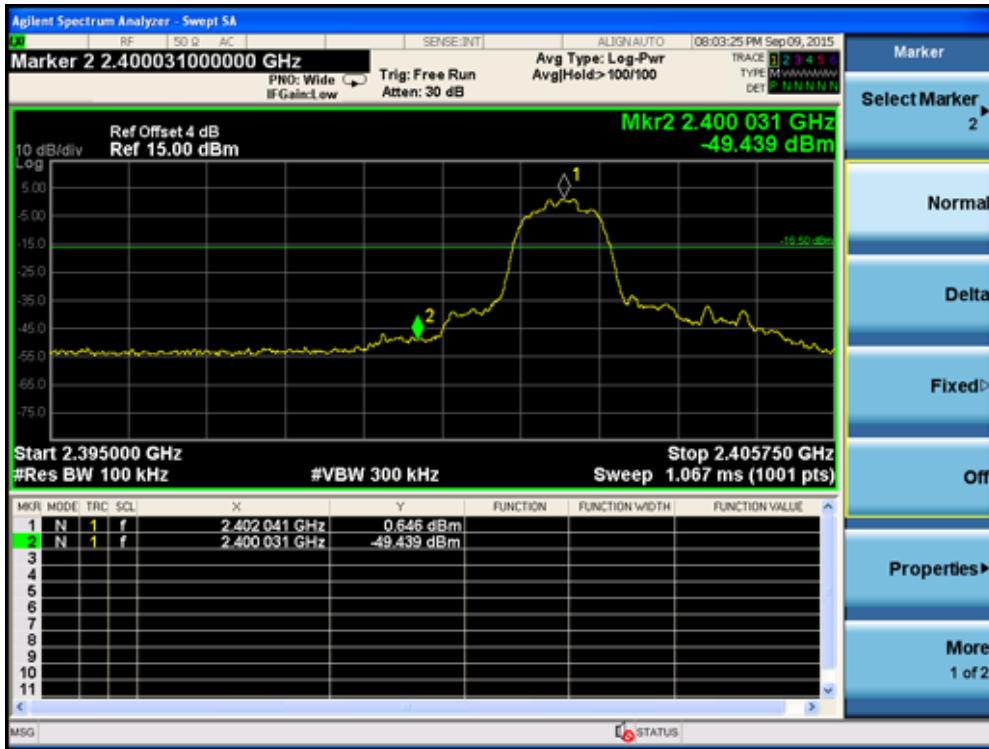

Channel 78 (2480MHz)

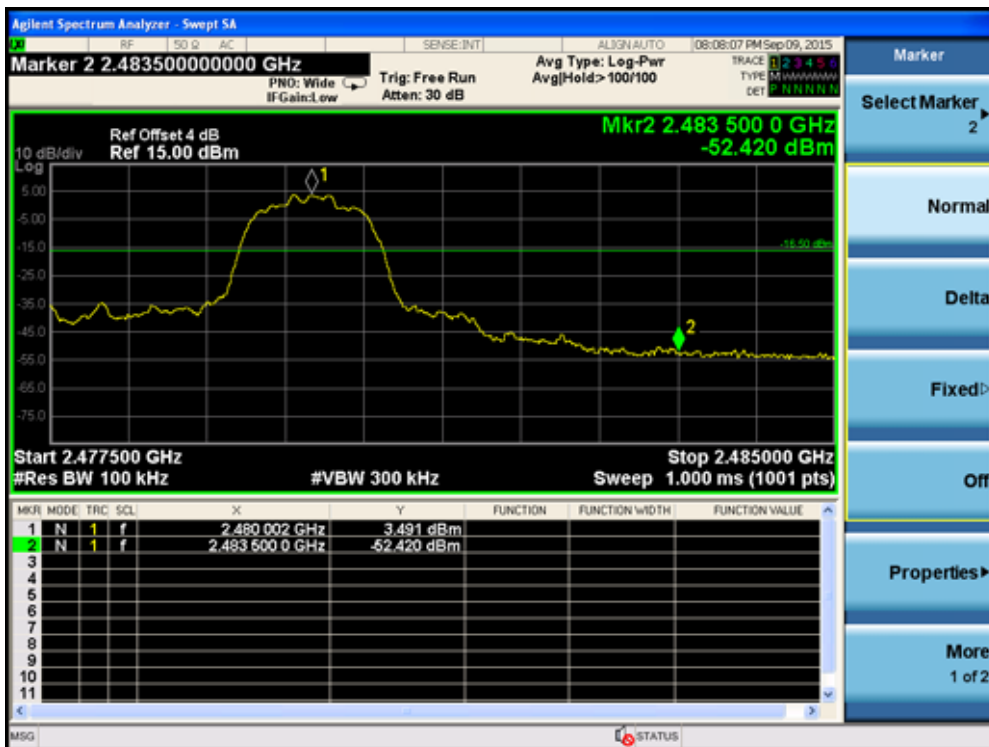

Product	: Zipp
Test Item	: Band-edge Compliance of RF Conducted Emissions
Test Site	: TR-8
Test Mode	: Mode: Hopping Mode

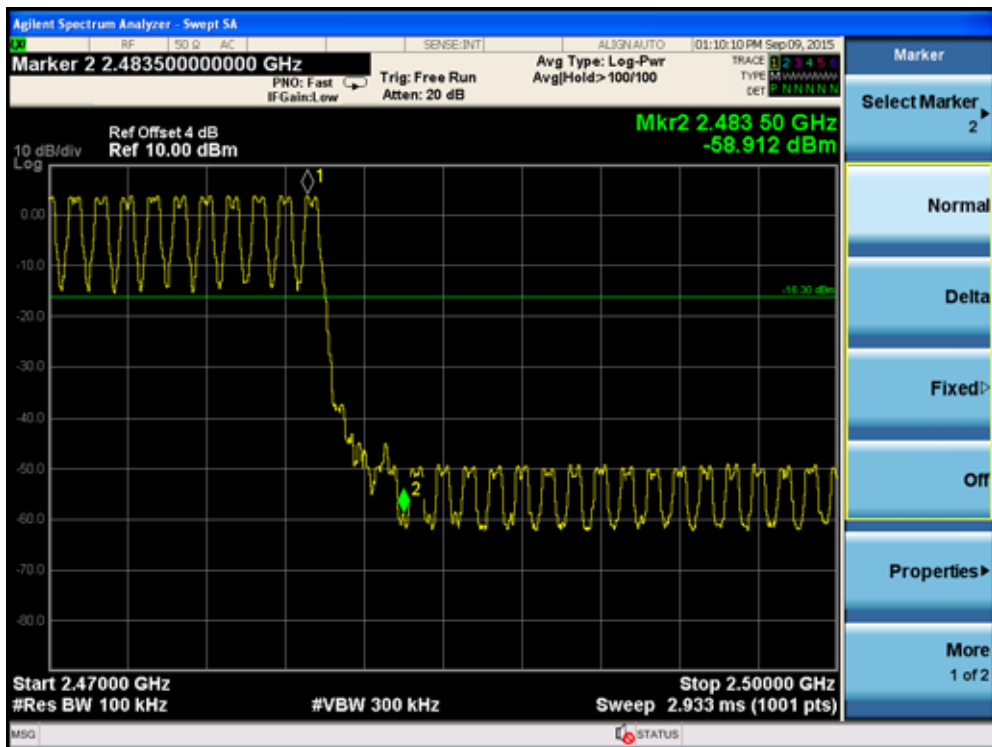
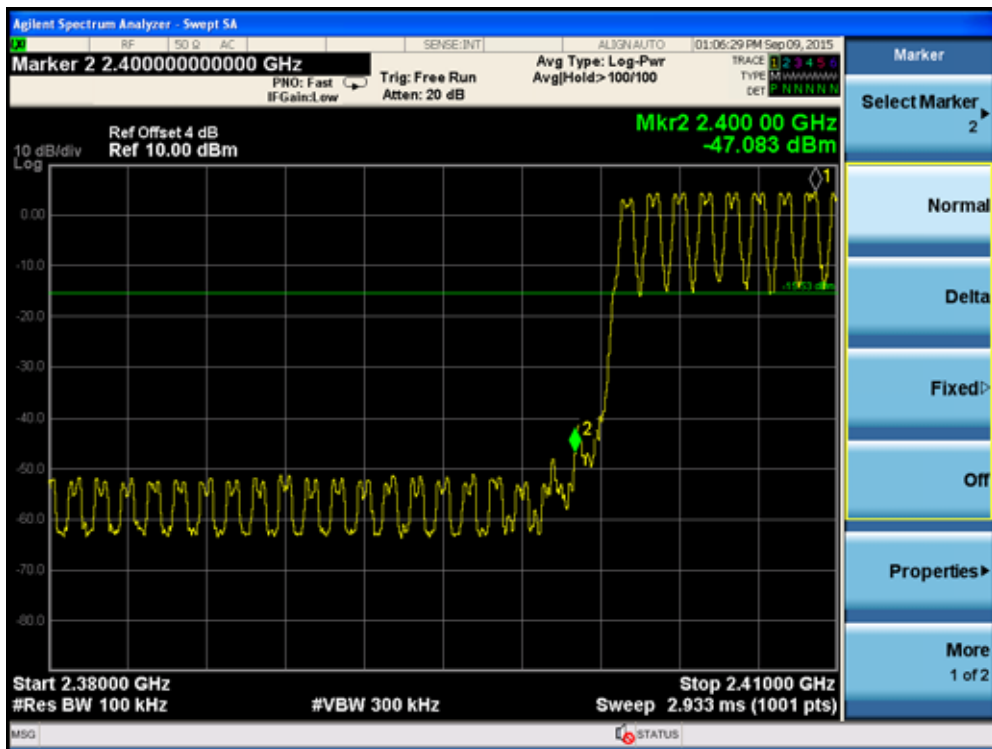

11. Spurious RF Conducted Emissions

11.1. Test Equipment

Spurious RF Conducted Emissions / TR-8

Instrument	Manufacturer	Type No.	Serial No.	Cal. Due Date
Spectrum Analyzer	Agilent	N9010A	MY48030494	2016.03.10
Temperature/Humidity Meter	Zhicheng	ZC1-2	TR8-TH	2016.04.09

Note: All equipments are calibrated with traceable calibrations. Each calibration is traceable to the national or international standards.

11.2. Test Setup

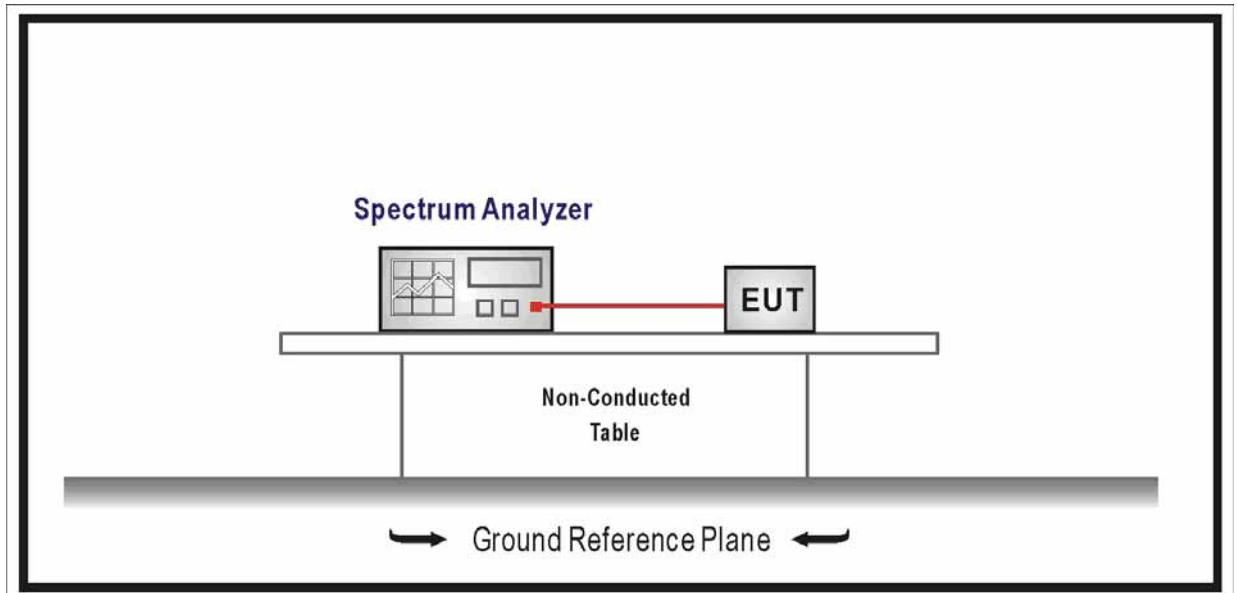

11.3. Limit

In any 100 kHz bandwidth outside the frequency band in which the spread spectrum or digitally modulated intentional radiator is operating, the radio frequency power that is produced by the intentional radiator shall be at least 20 dB below that in the 100 kHz bandwidth within the band that contains the highest level of the desired power, based on either an RF conducted or a radiated measurement, provided the transmitter demonstrates compliance with the peak conducted or a radiated measurement, provided the transmitter demonstrates compliance with the peak conducted power limits. If the transmitter complies with the conducted power limits based on the use of RMS averaging over a time interval, the attenuation required under this paragraph shall be 30 dB instead of 20 dB. Attenuation below the general limits specified in

Section 15.209(a) of FCC part 15 is not required.

11.4. Test Procedure

According to ANSI C63.10: 2013.

Use the following spectrum analyzer settings:

Span = wide enough to capture the peak level of the in-band emission and all spurious emissions (e.g., harmonics) from the lowest frequency generated in the EUT up through the 10th harmonic. Typically, several plots are required to cover this entire span.

RBW = 100 kHz

VBW \cong RBW

Sweep = auto

Detector function = peak

Trace = max hold

Allow the trace to stabilize. Set the marker on the peak of any spurious emission recorded.

The level displayed must comply with the limit specified in this section.

11.5. Uncertainty

The measurement uncertainty is defined as ± 1.0 dB

11.6. Test Result

Product	:	Zipp
Test Item	:	Spurious RF Conducted Emissions
Test Mode	:	Mode 1: Transmitter-1Mbps (GFSK_DH5)

Channel 00 (2402MHz)

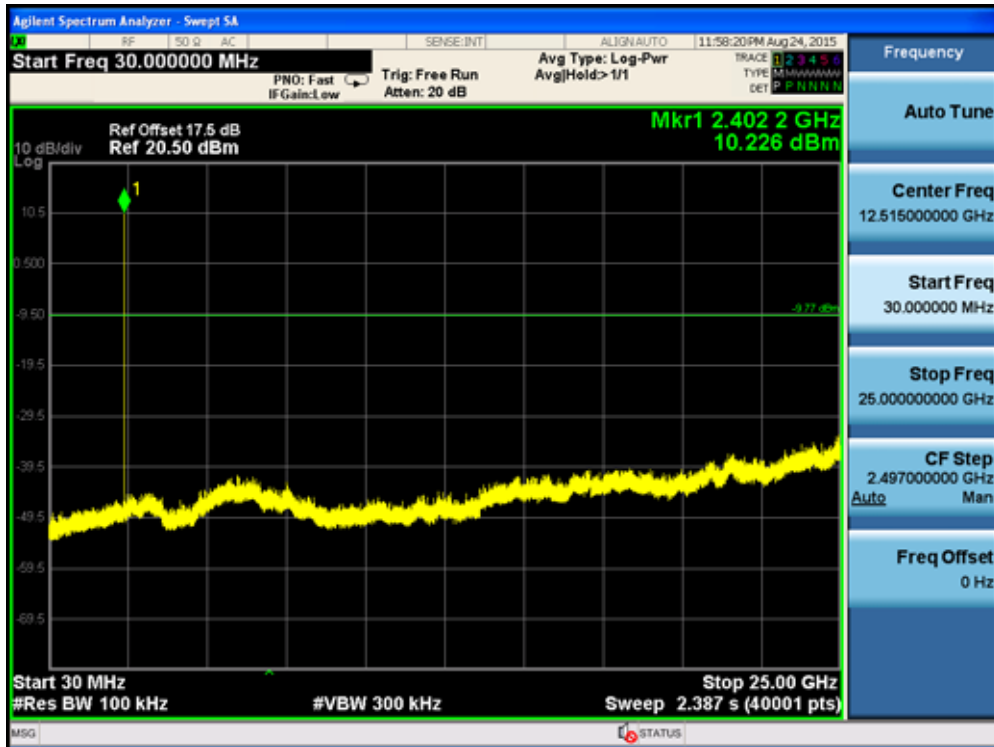

Channel 39 (2441MHz)

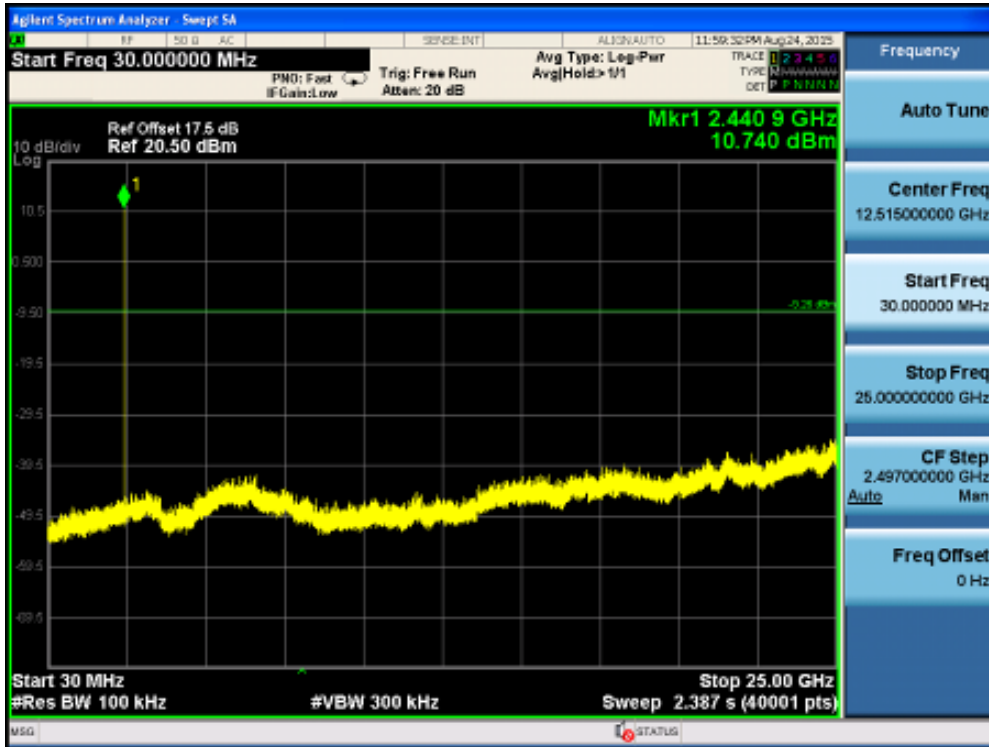

Channel 78 (2480MHz)

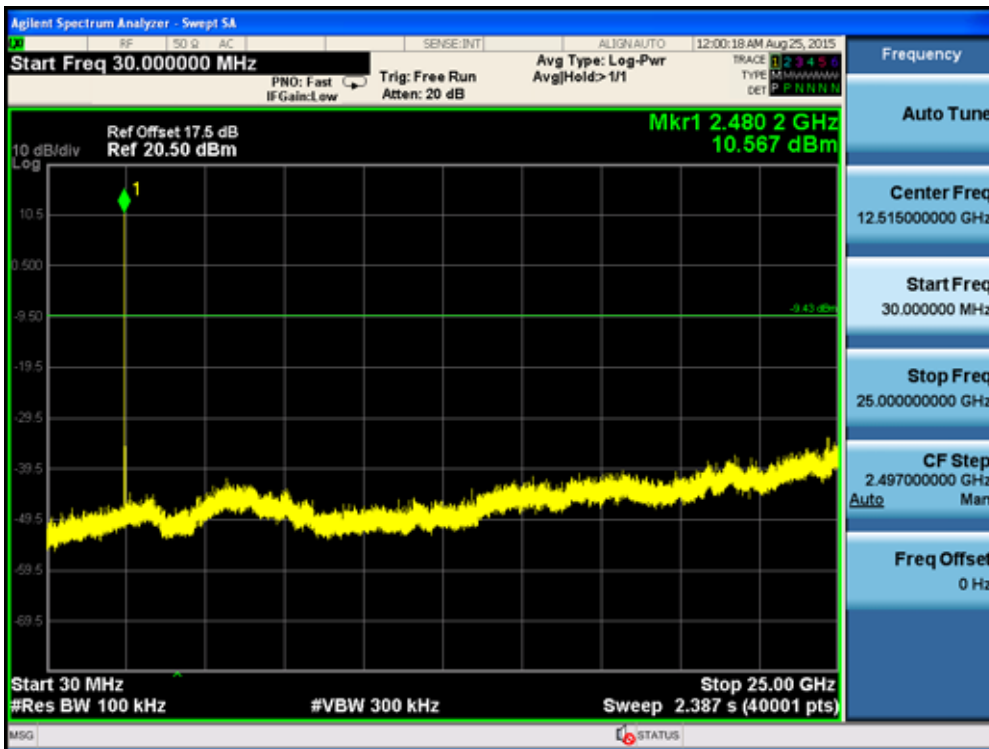

Product	:	Zipp
Test Item	:	Spurious RF Conducted Emissions
Test Mode	:	Mode 2: Transmitter-2Mbps (Pi/4 DQPSK_DH5)

Channel 00 (2402MHz)

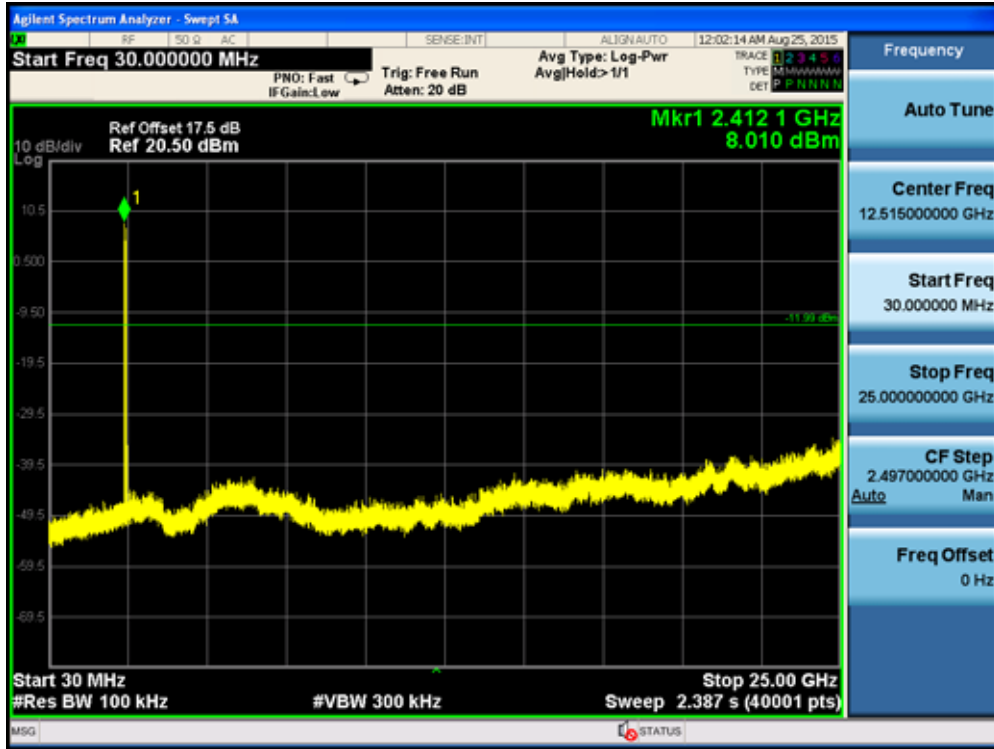

Channel 39 (2441MHz)

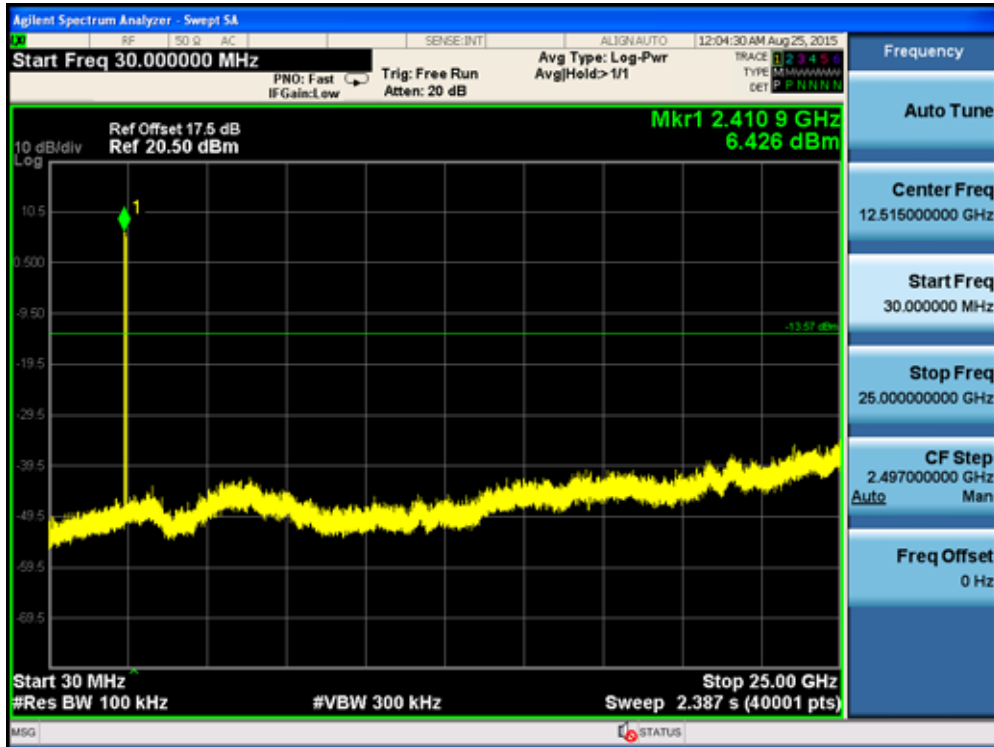

Channel 78 (2480MHz)

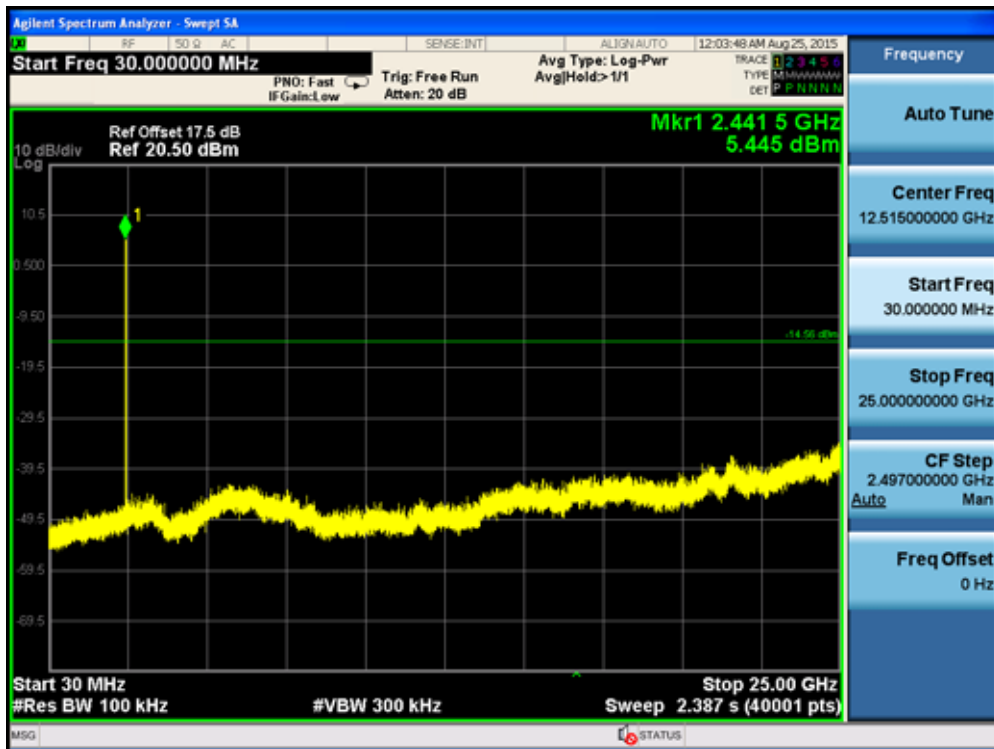

Product	:	Zipp
Test Item	:	Spurious RF Conducted Emissions
Test Mode	:	Mode 3: Transmitter-3Mbps (8DPSK_DH5)

Channel 00 (2402MHz)

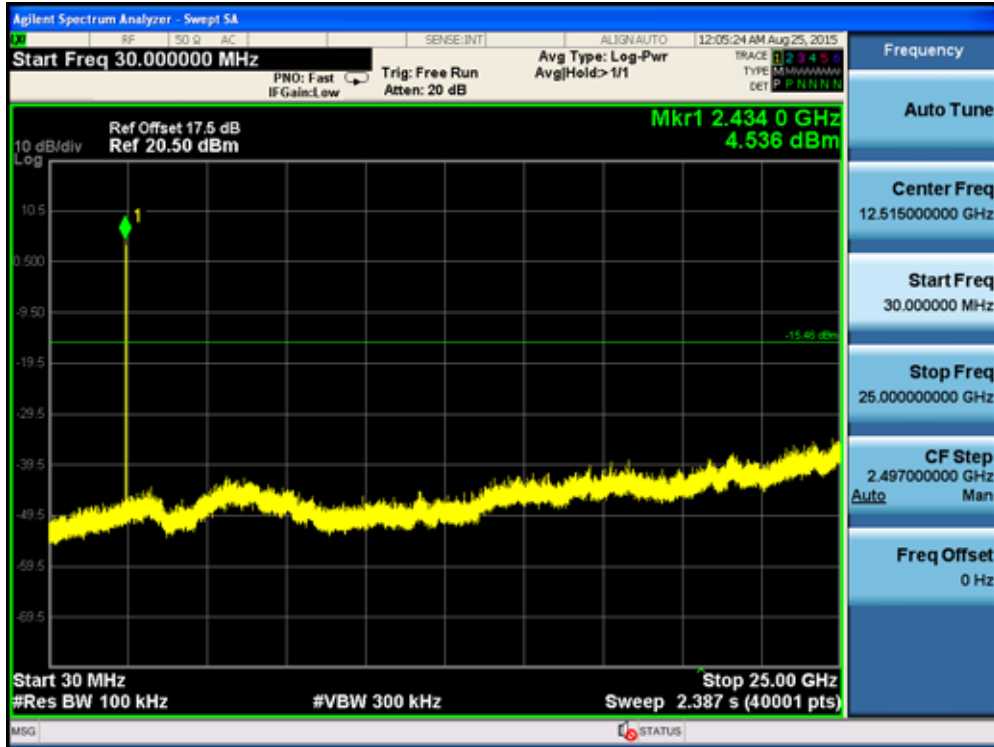

Channel 39 (2441MHz)

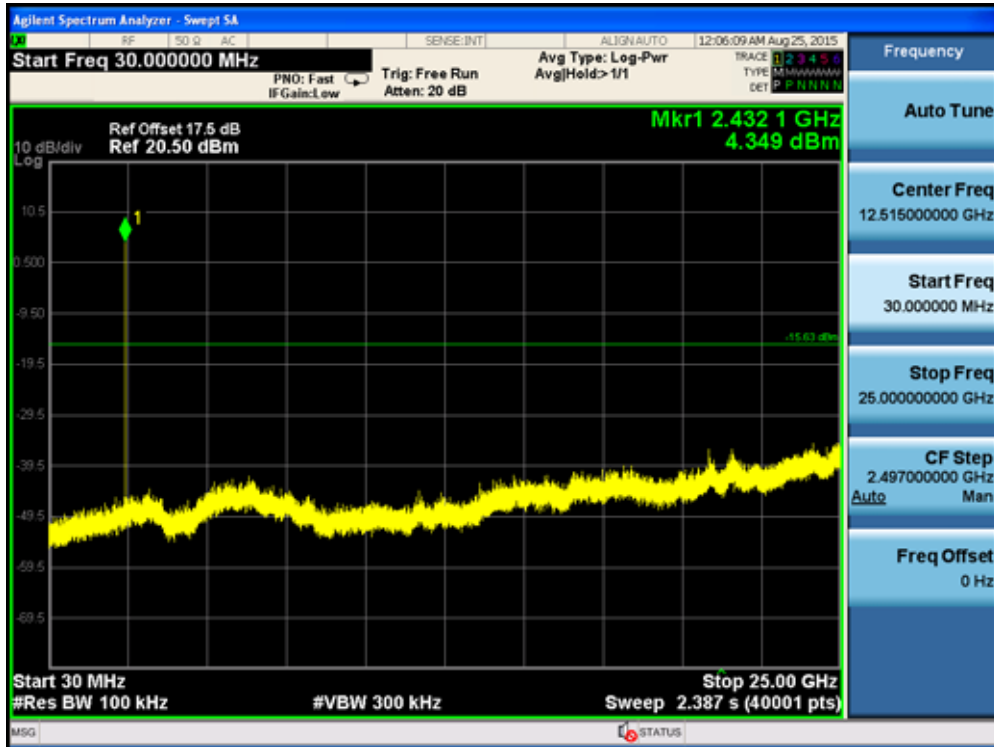

Channel 78 (2480MHz)

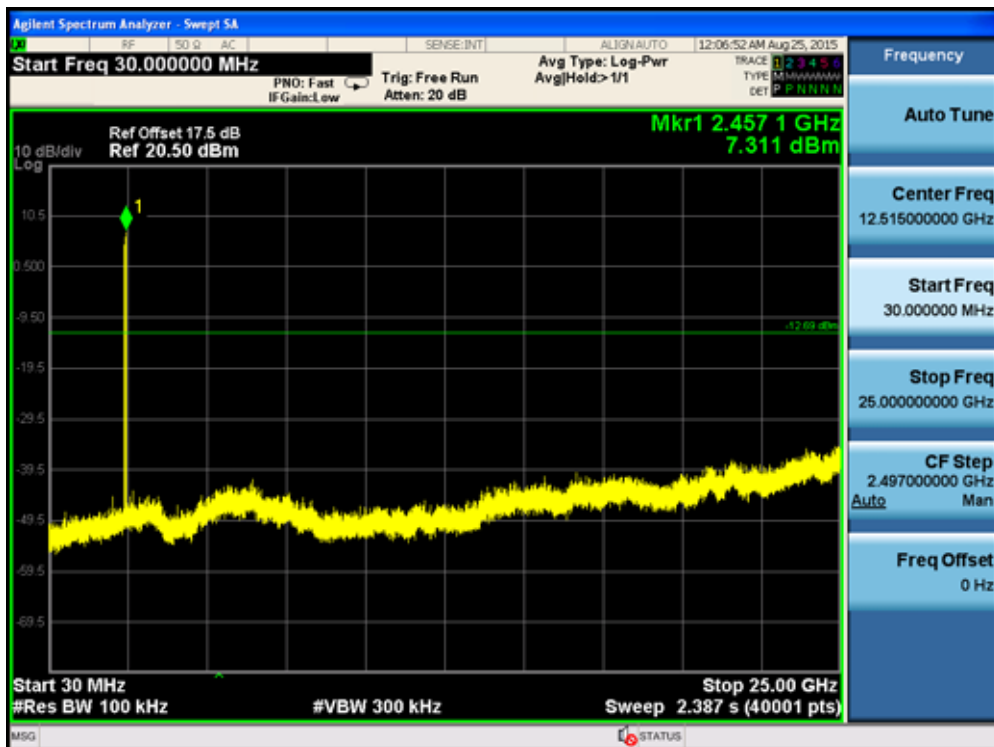

12. Radiated Emission Band Edge

12.1. Test Equipment

Radiated Emission Band Edge / AC-5

Instrument	Manufacturer	Type No.	Serial No.	Cal. Due Date
Spectrum Analyzer	Agilent	N9010A	MY48030494	2016.03.10
Preamplifier	Miteq	NSP1800-25	1364185	2016.05.03
Preamplifier	Quietek	AP-040G	CHM-0906001	2016.05.03
Bilog Antenna	Teseq GmbH	CBL6112D	27612	2015.10.15
Broad-Band Horn Antenna	Schwarzbeck	BBHA9120D	733	2016.02.26
DRG Horn	ETS-Lindgren	3117	00167055	2016.07.16
Broad-Band Horn Antenna	Schwarzbeck	BBHA9170	294	2016.03.01
Coaxial Cable	Huber+Suhner	SUCOFLEX 106	AC5-C1	2016.03.01
Coaxial Cable	Huber+Suhner	SUCOFLEX 106	AC5-C2	2016.03.01
Coaxial Cable	Huber+Suhner	SUCOFLEX 102	AC5-C3	2016.08.07
Temperature/Humidity Meter	Zhicheng	ZC1-2	AC5-TH	2016.01.07

12.2. Test Setup

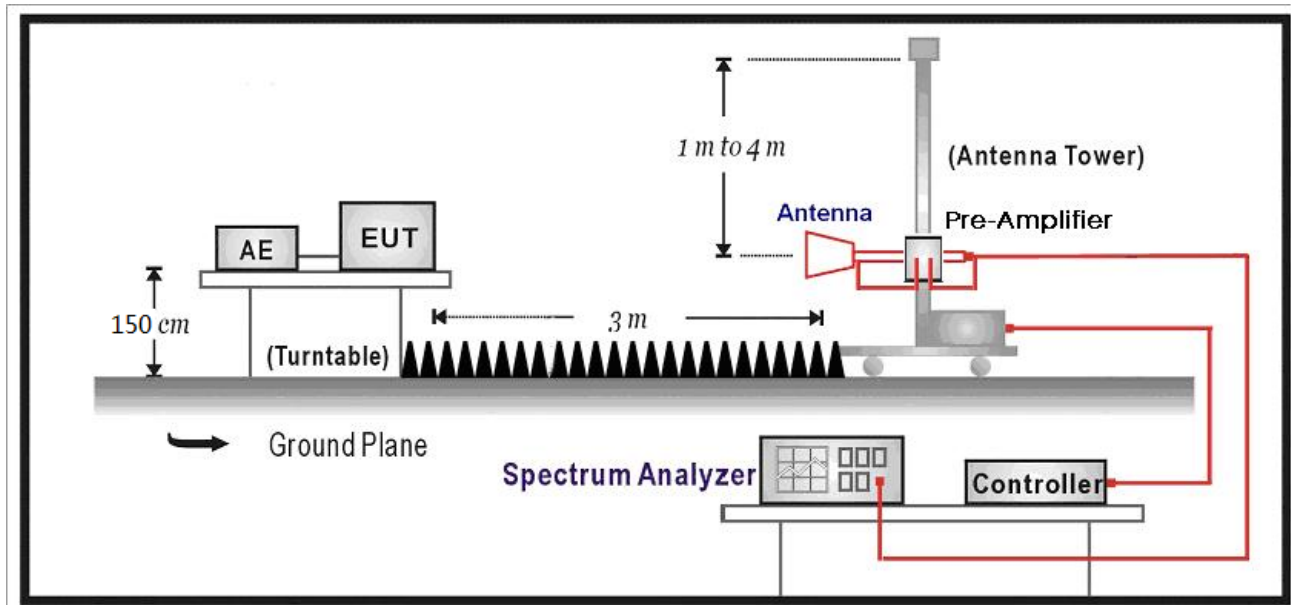

12.3. Limit

Radiated emissions which fall in the restricted bands, as defined in Section 15.205(a) of FCC part 15, must also comply with the radiated emission limits specified in Section 15.209(a) of FCC part 15.

12.4. Test Procedure

According to ANSI C63.10: 2013& ANSI C63.4: 2014

This test is required for any spurious emission or modulation product that falls in a Restricted Band, as defined in Section 15.205 of FCC part 15. It must be performed with the highest gain of each type of antenna proposed for use with the EUT. Use the following spectrum analyzer settings:

Span = wide enough to fully capture the emission being measured

RBW = 1 MHz for $f \geq 1$ GHz, 100 kHz for $f < 1$ GHz

VBW \geq RBW

Sweep = auto

Detector function = peak

Trace = max hold

Follow the guidelines in ANSI C63.4 with respect to maximizing the emission by rotating the EUT, measuring the emission while the EUT is situated in three orthogonal planes (if appropriate), adjusting the measurement antenna height and polarization, etc. A pre-amp and a high pass filter are required for this test, in order to provide the measuring system with

sufficient sensitivity. Allow the trace to stabilize. The peak reading of the emission, after being corrected by the antenna factor, cable loss, pre-amp gain, etc., is the peak field strength, which must comply with the limit specified in Section 15.35(b) of FCC part 15.

Now set the VBW to 10 Hz, while maintaining all of the other instrument settings. This peak level, once corrected, must comply with the limit specified in Section 15.209 of FCC Part 15. If the dwell time per channel of the hopping signal is less than 100 ms, then the reading obtained with the 10 Hz VBW may be further adjusted by a “duty cycle correction factor”, derived from $20\log(\text{dwell time}/100 \text{ ms})$, in an effort to demonstrate compliance with the 15.209 limit of FCC part 15.

If the emission on which a radiated measurement must be made is located at the edge of the authorized band of operation, then the alternative “marker-Zipp” method may be employed.

12.5. Uncertainty

The measurement uncertainty above 1G is defined as $\pm 3.9 \text{ dB}$

below 1G is defined as $\pm 3.8 \text{ dB}$

12.6. Test Result

All of the test result shown indicates the worst case, and spectrum analyzer parameters setting as shown below:

Peak detector: RBW = 1MHz, VBW = 3MHz, sweep time = 100ms;

Average = Peak Measure Level+ Duty Factor

Duty Factor= $20 * \text{LOG}(\text{Pulse Number} * \text{On Time} / 100) = -30.82\text{dB}$ in worst condition in normal use.

Pulse Number



Engineer: Scott	
Site: AC5	Time: 2015/09/20 - 09:50
Limit: FCC_Part15.209_RE(3m)	Margin: 0
Probe: Horn_3117_00167055(1-18GHz)	Polarity: Vertical
EUT: Zipp	Power: AC 120V/60Hz
Note: Mode 1:Transmit at 2402Mhz by DH5	

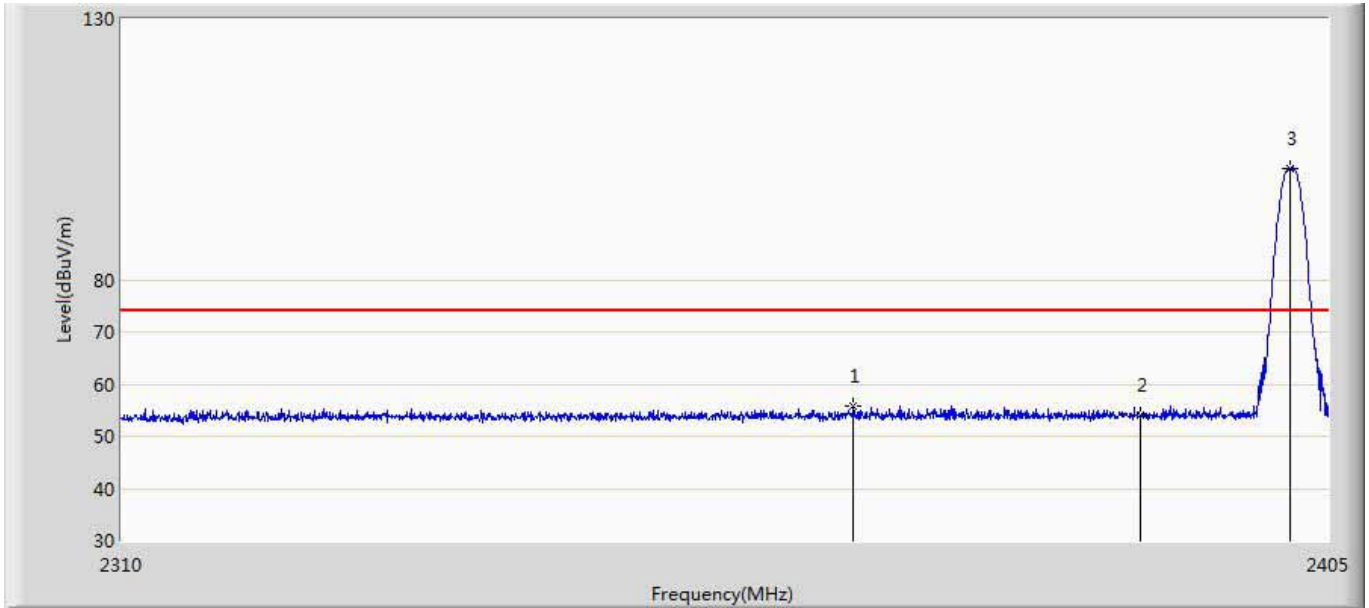

No	Mark	Frequency (MHz)	Measure Level (dBuV/m)	Reading Level (dBuV)	Over Limit (dB)	Limit (dBuV/m)	Factor (dB)	Type
1		2367.190	55.864	18.972	-18.136	74.000	36.892	PK
2		2390.000	54.009	17.018	-19.991	74.000	36.991	PK
3	*	2401.913	101.339	64.333	N/A	N/A	37.007	PK

No	Mark	Frequency (MHz)	Peak Level (dBuV/m)	AV Level (dBuV)	Over Limit (dB)	Limit (dBuV/m)	Duty Factor (dB)	Type
1		2367.190	55.864	25.044	-28.956	54.000	-30.82	AV
2		2390.000	54.009	23.189	-30.811	54.000	-30.82	AV
3	*	2401.913	101.339	70.519	N/A	N/A	-30.82	AV

Engineer: Scott	
Site: AC5	Time: 2015/09/20 - 09:53
Limit: FCC_Part15.209_RE(3m)	Margin: 0
Probe: Horn_3117_00167055(1-18GHz)	Polarity: Horizontal
EUT: Zipp	Power: AC 120V/60Hz
Note: Mode 1:Transmit at 2402Mhz by DH5	

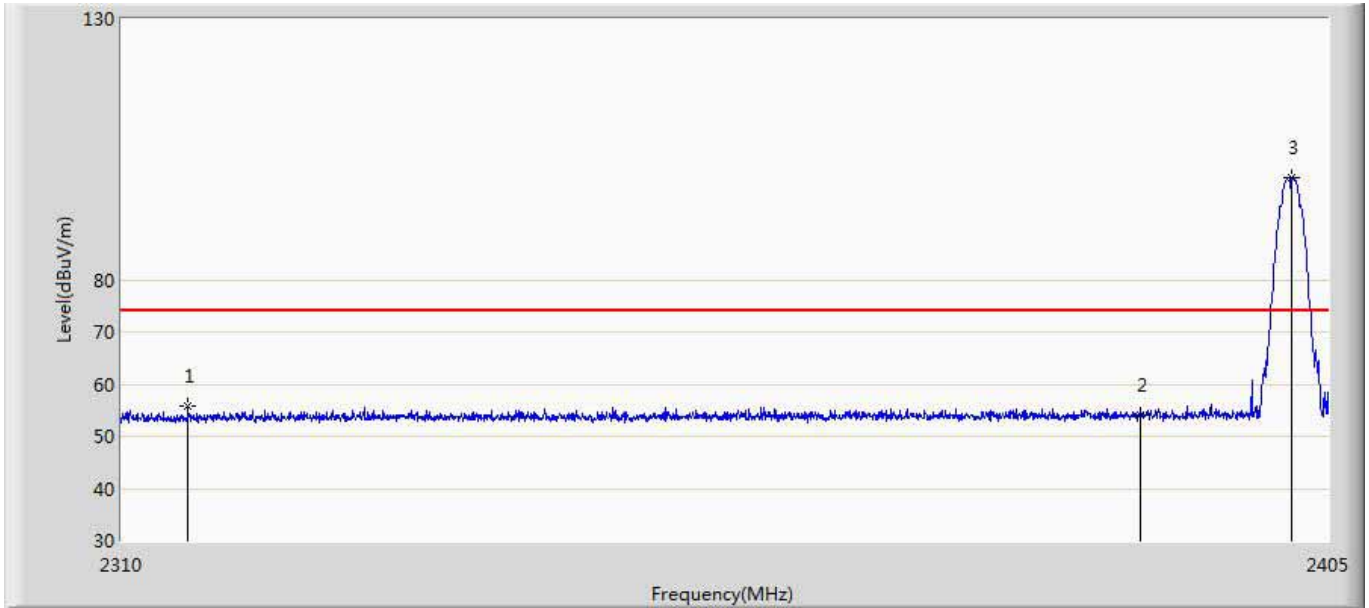

No	Mark	Frequency (MHz)	Measure Level (dBuV/m)	Reading Level (dBuV)	Over Limit (dB)	Limit (dBuV/m)	Factor (dB)	Type
1		2315.130	55.790	19.165	-18.210	74.000	36.624	PK
2		2390.000	54.004	17.013	-19.996	74.000	36.991	PK
3	*	2402.103	99.621	62.614	N/A	N/A	37.007	PK

No	Mark	Frequency (MHz)	Peak Level (dBuV/m)	AV Level (dBuV)	Over Limit (dB)	Limit (dBuV/m)	Duty Factor (dB)	Type
1		2315.130	55.790	24.970	-29.030	54.000	-30.82	AV
2		2390.000	54.004	23.184	-30.816	54.000	-30.82	AV
3	*	2402.103	99.621	68.801	N/A	N/A	-30.82	AV

Engineer: Scott	
Site: AC5	Time: 2015/09/20 - 10:00
Limit: FCC_Part15.209_RE(3m)	Margin: 0
Probe: Horn_3117_00167055(1-18GHz)	Polarity: Vertical
EUT: Zipp	Power: AC 120V/60Hz
Note: Mode 1:Transmit at 2480Mhz by DH5	

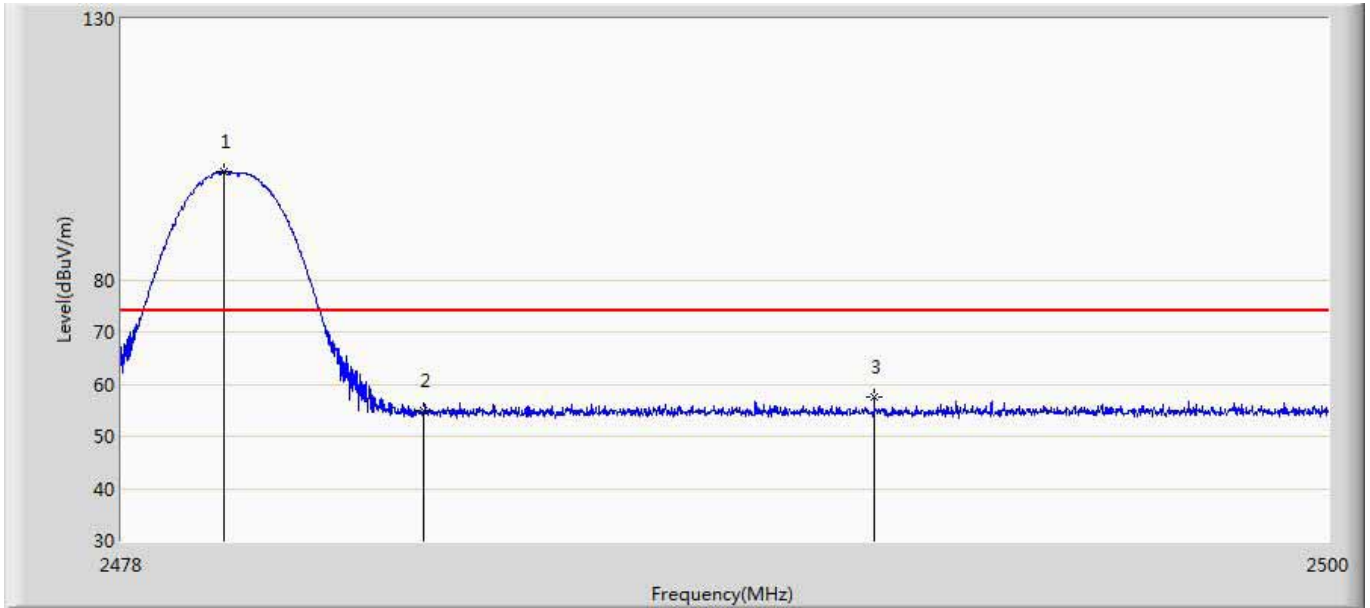

No	Mark	Frequency (MHz)	Measure Level (dBuV/m)	Reading Level (dBuV)	Over Limit (dB)	Limit (dBuV/m)	Factor (dB)	Type
1	*	2479.870	100.657	63.321	N/A	N/A	37.336	PK
2		2483.500	54.984	17.613	-19.016	74.000	37.371	PK
3		2491.706	57.605	20.154	-16.395	74.000	37.450	PK

No	Mark	Frequency (MHz)	Peak Level (dBuV/m)	AV Level (dBuV)	Over Limit (dB)	Limit (dBuV/m)	Duty Factor (dB)	Type
1	*	2479.870	100.657	69.837	N/A	N/A	-30.82	AV
2		2483.500	54.984	24.164	-29.836	54.000	-30.82	AV
3		2491.706	57.605	26.785	-27.215	54.000	-30.82	AV

Engineer: Scott	
Site: AC5	Time: 2015/09/20 - 10:03
Limit: FCC_Part15.209_RE(3m)	Margin: 0
Probe: Horn_3117_00167055(1-18GHz)	Polarity: Horizontal
EUT: Zipp	Power: AC 120V/60Hz
Note: Mode 1:Transmit at 2480Mhz by DH5	

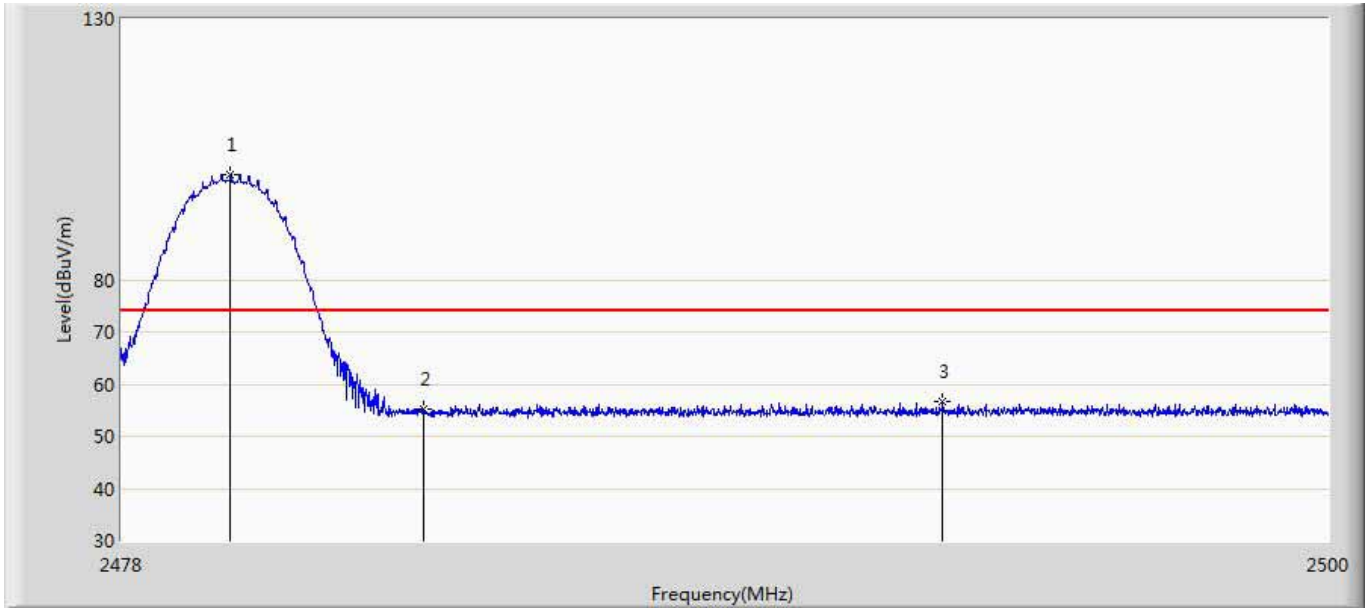

No	Mark	Frequency (MHz)	Measure Level (dBuV/m)	Reading Level (dBuV)	Over Limit (dB)	Limit (dBuV/m)	Factor (dB)	Type
1	*	2479.980	100.200	62.863	N/A	N/A	37.338	PK
2		2483.500	55.236	17.865	-18.764	74.000	37.371	PK
3		2492.949	56.594	19.131	-17.406	74.000	37.463	PK

No	Mark	Frequency (MHz)	Peak Level (dBuV/m)	AV Level (dBuV)	Over Limit (dB)	Limit (dBuV/m)	Duty Factor (dB)	Type
1	*	2479.980	100.200	69.380	N/A	N/A	-30.82	AV
2		2483.500	55.236	24.416	-29.584	54.000	-30.82	AV
3		2492.949	56.594	25.774	-28.226	54.000	-30.82	AV

Engineer: Scott	
Site: AC5	Time: 2015/09/20 - 10:46
Limit: FCC_Part15.209_RE(3m)	Margin: 0
Probe: Horn_3117_00167055(1-18GHz)	Polarity: Vertical
EUT: Zipp	Power: AC 120V/60Hz
Note: Mode 1:Transmit at 2402Mhz by 2DH5	

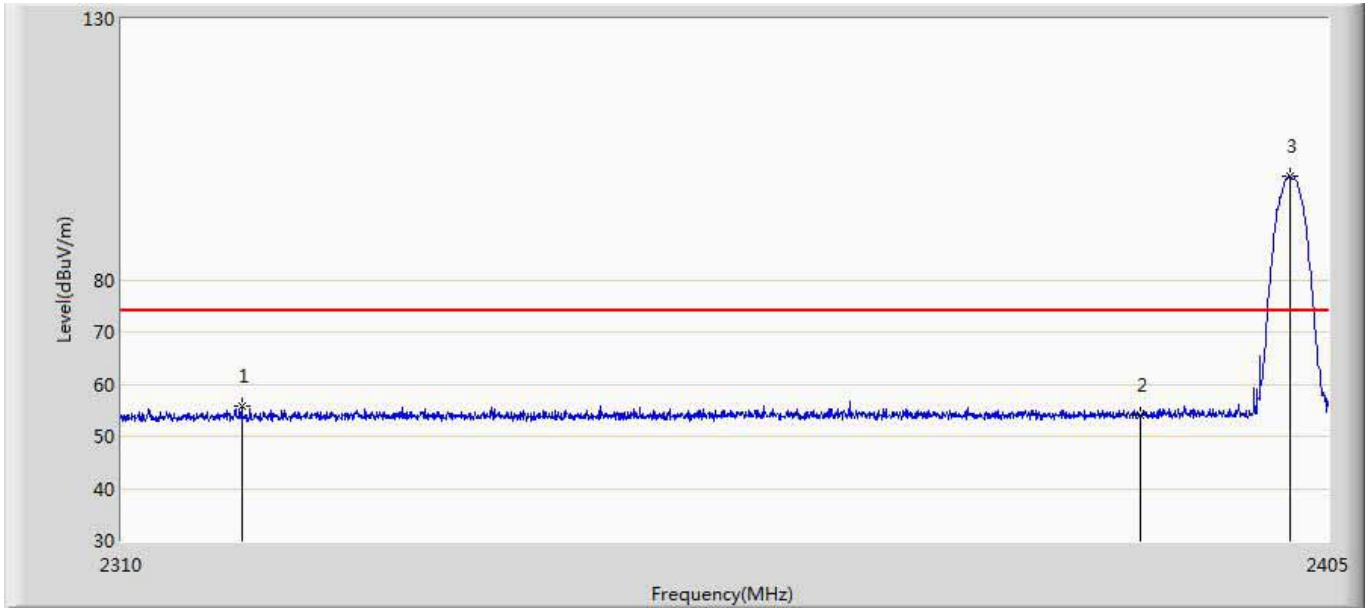

No	Mark	Frequency (MHz)	Measure Level (dBuV/m)	Reading Level (dBuV)	Over Limit (dB)	Limit (dBuV/m)	Factor (dB)	Type
1		2319.310	55.752	19.082	-18.248	74.000	36.671	PK
2		2390.000	54.008	17.017	-19.992	74.000	36.991	PK
3	*	2401.913	99.737	62.731	N/A	N/A	37.007	PK

No	Mark	Frequency (MHz)	Peak Level (dBuV/m)	AV Level (dBuV)	Over Limit (dB)	Limit (dBuV/m)	Duty Factor (dB)	Type
1		2319.310	55.752	24.932	-29.068	54.000	-30.82	AV
2		2390.000	54.008	23.188	-30.812	54.000	-30.82	AV
3	*	2401.913	99.737	68.917	N/A	N/A	-30.82	AV

Engineer: Scott	
Site: AC5	Time: 2015/09/20 - 10:49
Limit: FCC_Part15.209_RE(3m)	Margin: 0
Probe: Horn_3117_00167055(1-18GHz)	Polarity: Horizontal
EUT: Zipp	Power: AC 120V/60Hz
Note: Mode 1:Transmit at 2402Mhz by 2DH5	

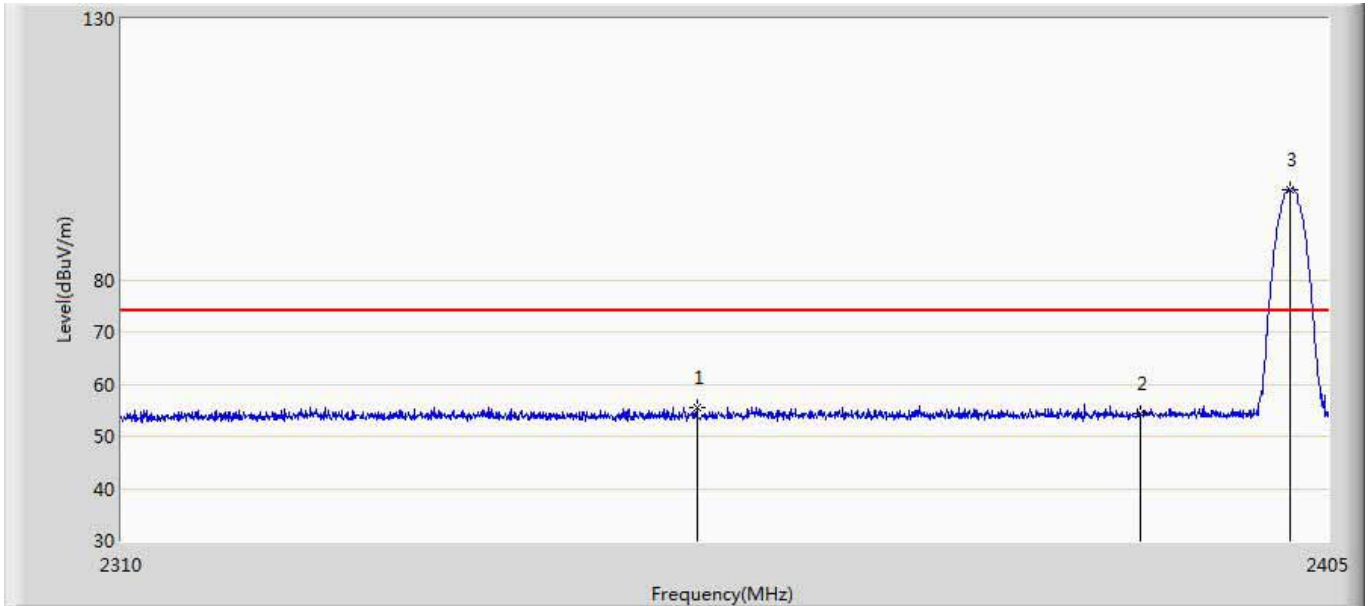

No	Mark	Frequency (MHz)	Measure Level (dBuV/m)	Reading Level (dBuV)	Over Limit (dB)	Limit (dBuV/m)	Factor (dB)	Type
1		2354.840	55.508	18.696	-18.492	74.000	36.812	PK
2		2390.000	54.455	17.464	-19.545	74.000	36.991	PK
3	*	2402.008	97.338	60.331	N/A	N/A	37.006	PK

No	Mark	Frequency (MHz)	Peak Level (dBuV/m)	AV Level (dBuV)	Over Limit (dB)	Limit (dBuV/m)	Duty Factor (dB)	Type
1		2354.840	55.508	24.688	-29.312	54.000	-30.82	AV
2		2390.000	54.455	23.635	-30.365	54.000	-30.82	AV
3	*	2402.008	97.338	66.518	N/A	N/A	-30.82	AV

Engineer: Scott	
Site: AC5	Time: 2015/09/20 - 10:56
Limit: FCC_Part15.209_RE(3m)	Margin: 0
Probe: Horn_3117_00167055(1-18GHz)	Polarity: Vertical
EUT: Zipp	Power: AC 120V/60Hz
Note: Mode 1:Transmit at 2480Mhz by 2DH5	

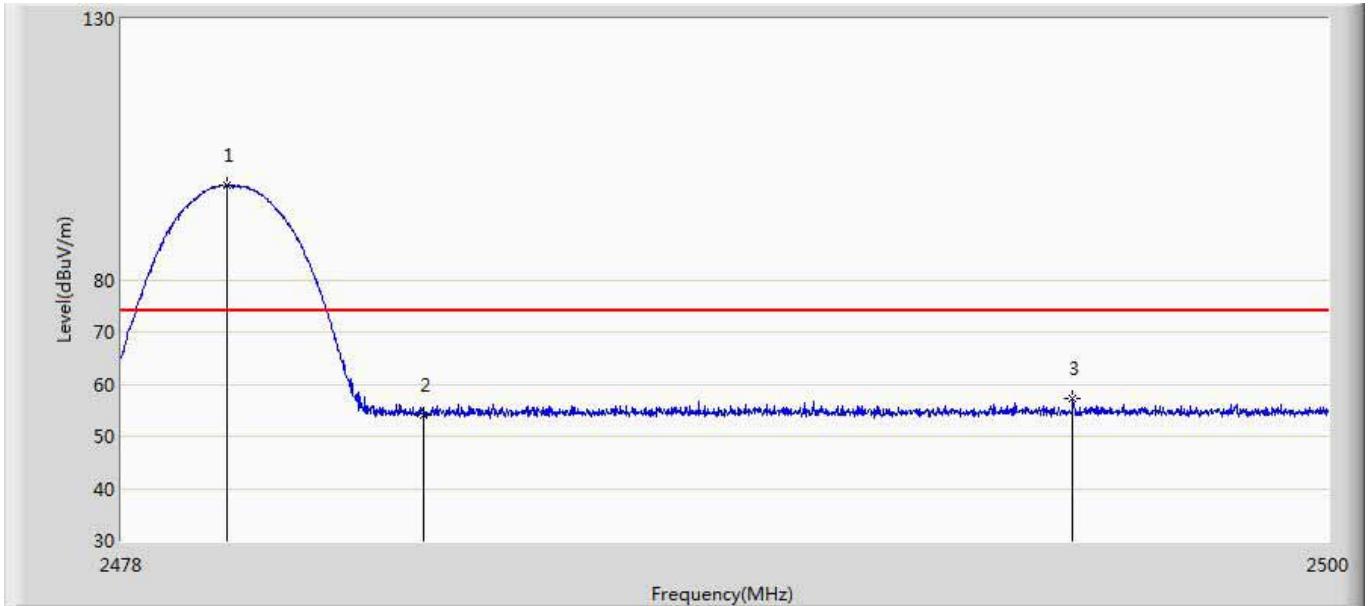

No	Mark	Frequency (MHz)	Measure Level (dBuV/m)	Reading Level (dBuV)	Over Limit (dB)	Limit (dBuV/m)	Factor (dB)	Type
1	*	2479.914	98.011	60.674	N/A	N/A	37.336	PK
2		2483.500	54.029	16.658	-19.971	74.000	37.371	PK
3		2495.336	57.122	19.636	-16.878	74.000	37.486	PK

No	Mark	Frequency (MHz)	Peak Level (dBuV/m)	AV Level (dBuV)	Over Limit (dB)	Limit (dBuV/m)	Duty Factor (dB)	Type
1	*	2479.914	98.011	67.191	N/A	N/A	-30.82	AV
2		2483.500	54.029	23.209	-30.791	54.000	-30.82	AV
3		2495.336	57.122	26.302	-27.698	54.000	-30.82	AV

Engineer: Scott	
Site: AC5	Time: 2015/09/20 - 11:00
Limit: FCC_Part15.209_RE(3m)	Margin: 0
Probe: Horn_3117_00167055(1-18GHz)	Polarity: Horizontal
EUT: Zipp	Power: AC 120V/60Hz
Note: Mode 1:Transmit at 2480Mhz by 2DH5	

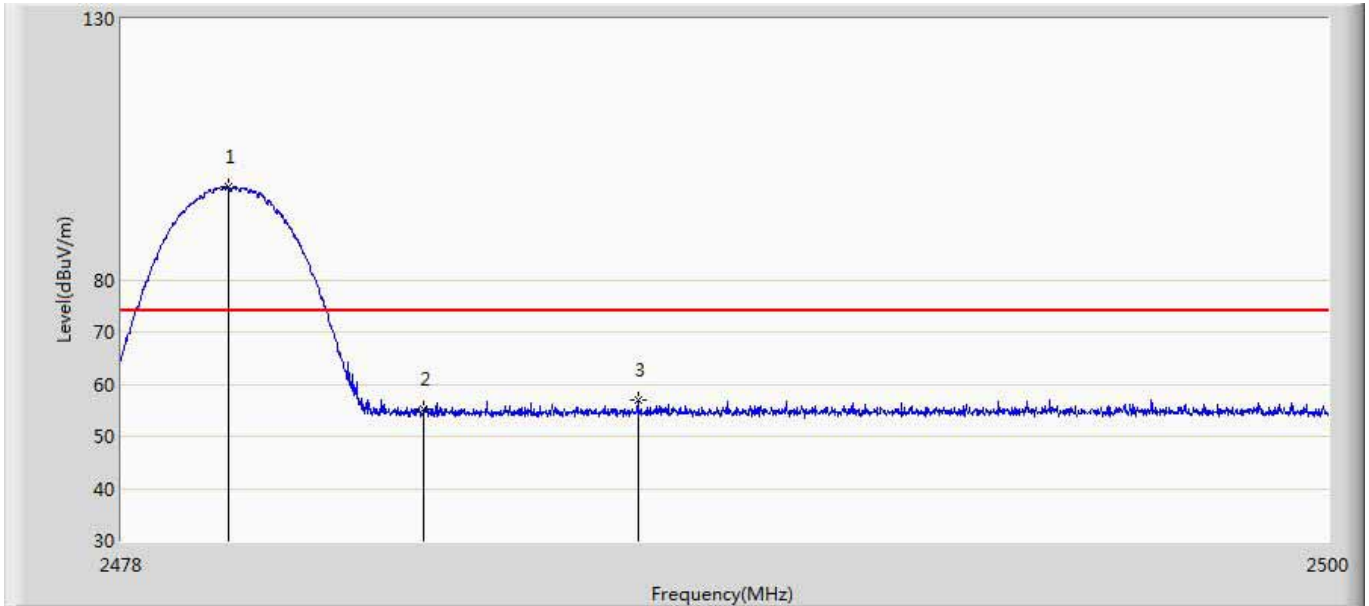

No	Mark	Frequency (MHz)	Measure Level (dBuV/m)	Reading Level (dBuV)	Over Limit (dB)	Limit (dBuV/m)	Factor (dB)	Type
1	*	2479.947	97.772	60.435	N/A	N/A	37.337	PK
2		2483.500	55.207	17.836	-18.793	74.000	37.371	PK
3		2487.394	56.938	19.529	-17.062	74.000	37.409	PK

No	Mark	Frequency (MHz)	Peak Level (dBuV/m)	AV Level (dBuV)	Over Limit (dB)	Limit (dBuV/m)	Duty Factor (dB)	Type
1	*	2479.947	97.772	66.952	N/A	N/A	-30.82	AV
2		2483.500	55.207	24.387	-29.613	54.000	-30.82	AV
3		2487.394	56.938	26.118	-27.882	54.000	-30.82	AV

Engineer: Scott	
Site: AC5	Time: 2015/09/20 - 11:15
Limit: FCC_Part15.209_RE(3m)	Margin: 0
Probe: Horn_3117_00167055(1-18GHz)	Polarity: Vertical
EUT: Zipp	Power: AC 120V/60Hz
Note: Mode 1:Transmit at 2402Mhz by 3DH5	

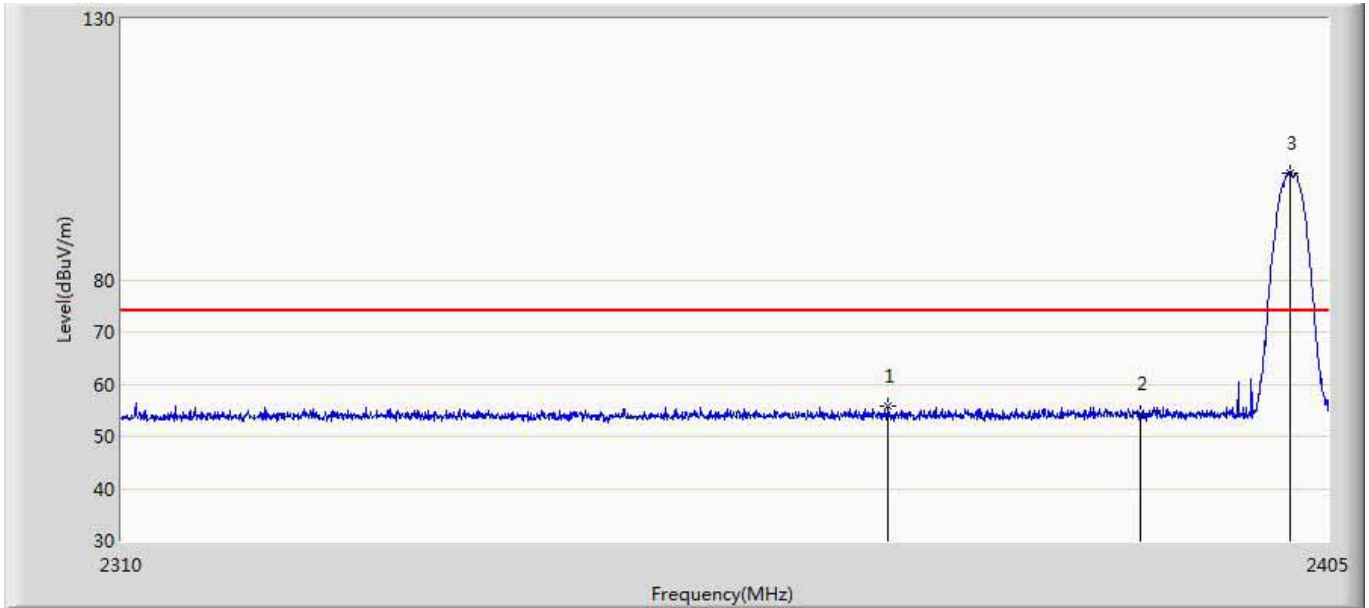

No	Mark	Frequency (MHz)	Measure Level (dBuV/m)	Reading Level (dBuV)	Over Limit (dB)	Limit (dBuV/m)	Factor (dB)	Type
1		2369.897	55.655	18.743	-18.345	74.000	36.912	PK
2		2390.000	54.312	17.321	-19.688	74.000	36.991	PK
3	*	2401.913	100.548	63.542	N/A	N/A	37.007	PK

No	Mark	Frequency (MHz)	Peak Level (dBuV/m)	AV Level (dBuV)	Over Limit (dB)	Limit (dBuV/m)	Duty Factor (dB)	Type
1		2369.897	55.655	24.835	-29.165	54.000	-30.82	AV
2		2390.000	54.312	23.492	-30.508	54.000	-30.82	AV
3	*	2401.913	100.548	69.728	N/A	N/A	-30.82	AV

Engineer: Scott	
Site: AC5	Time: 2015/09/20 - 11:18
Limit: FCC_Part15.209_RE(3m)	Margin: 0
Probe: Horn_3117_00167055(1-18GHz)	Polarity: Horizontal
EUT: Zipp	Power: AC 120V/60Hz
Note: Mode 1:Transmit at 2402Mhz by 3DH5	

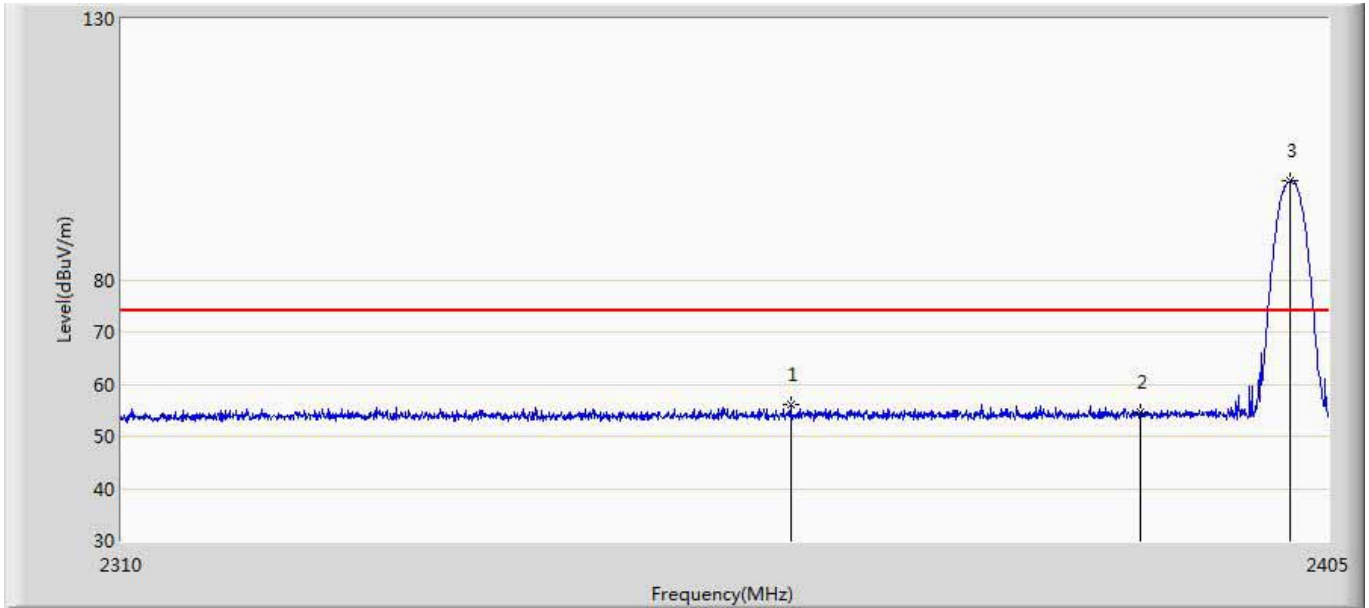

No	Mark	Frequency (MHz)	Measure Level (dBuV/m)	Reading Level (dBuV)	Over Limit (dB)	Limit (dBuV/m)	Factor (dB)	Type
1		2362.250	56.173	19.318	-17.827	74.000	36.855	PK
2		2390.000	54.550	17.559	-19.450	74.000	36.991	PK
3	*	2401.913	98.887	61.881	N/A	N/A	37.007	PK

No	Mark	Frequency (MHz)	Peak Level (dBuV/m)	AV Level (dBuV)	Over Limit (dB)	Limit (dBuV/m)	Duty Factor (dB)	Type
1		2362.250	56.173	25.353	-28.647	54.000	-30.82	AV
2		2390.000	54.550	23.730	-30.270	54.000	-30.82	AV
3	*	2401.913	98.887	68.067	N/A	N/A	-30.82	AV

Engineer: Scott	
Site: AC5	Time: 2015/09/20 - 11:22
Limit: FCC_Part15.209_RE(3m)	Margin: 0
Probe: Horn_3117_00167055(1-18GHz)	Polarity: Vertical
EUT: Zipp	Power: AC 120V/60Hz
Note: Mode 1:Transmit at 2480Mhz by 3DH5	

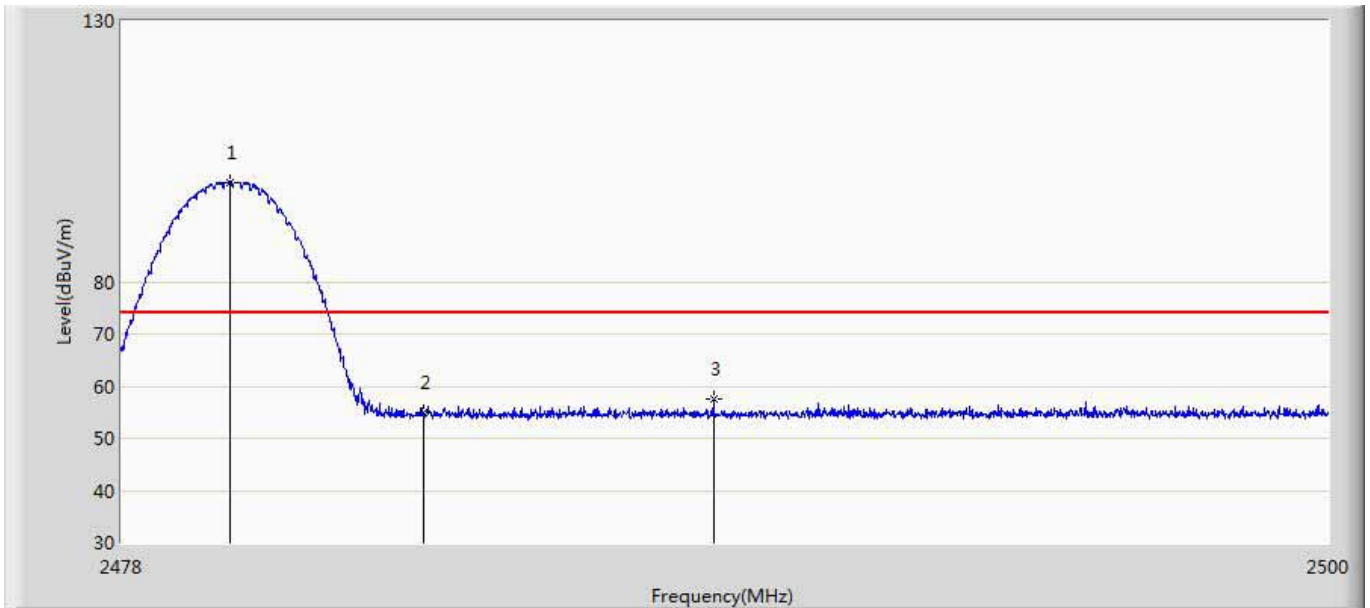

No	Mark	Frequency (MHz)	Measure Level (dBuV/m)	Reading Level (dBuV)	Over Limit (dB)	Limit (dBuV/m)	Factor (dB)	Type
1	*	2479.980	99.119	61.782	N/A	N/A	37.338	PK
2		2483.500	54.928	17.557	-19.072	74.000	37.371	PK
3		2488.769	57.426	20.004	-16.574	74.000	37.423	PK

No	Mark	Frequency (MHz)	Peak Level (dBuV/m)	AV Level (dBuV)	Over Limit (dB)	Limit (dBuV/m)	Duty Factor (dB)	Type
1	*	2479.980	99.119	68.299	N/A	N/A	-30.82	AV
2		2483.500	54.928	24.108	-29.892	54.000	-30.82	AV
3		2488.769	57.426	26.606	-27.394	54.000	-30.82	AV

Engineer: Scott	
Site: AC5	Time: 2015/09/20 - 11:24
Limit: FCC_Part15.209_RE(3m)	Margin: 0
Probe: Horn_3117_00167055(1-18GHz)	Polarity: Horizontal
EUT: Zipp	Power: AC 120V/60Hz
Note: Mode 1:Transmit at 2480Mhz by 3DH5	

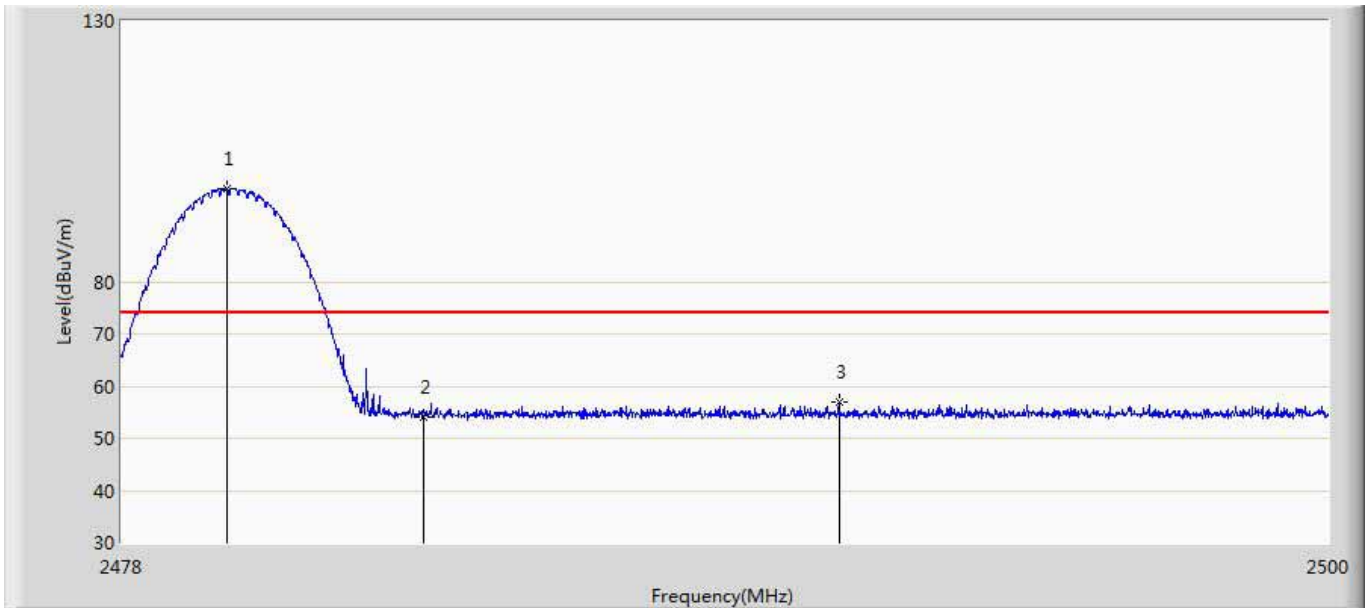

No	Mark	Frequency (MHz)	Measure Level (dBuV/m)	Reading Level (dBuV)	Over Limit (dB)	Limit (dBuV/m)	Factor (dB)	Type
1	*	2479.914	97.793	60.456	N/A	N/A	37.336	PK
2		2483.500	54.058	16.687	-19.942	74.000	37.371	PK
3		2491.068	57.043	19.598	-16.957	74.000	37.445	PK

No	Mark	Frequency (MHz)	Peak Level (dBuV/m)	AV Level (dBuV)	Over Limit (dB)	Limit (dBuV/m)	Duty Factor (dB)	Type
1	*	2479.914	97.793	66.973	N/A	N/A	-30.82	AV
2		2483.500	54.058	23.238	-30.762	54.000	-30.82	AV
3		2491.068	57.043	26.223	-27.777	54.000	-30.82	AV

————— The End —————