

FCC TEST REPORT

FCC ID:Y2P-GSX1204

Report Number..... : ZKT-220616L4103-2

Date of Test..... Jun. 06, 2021 to Jun. 21, 2022

Date of issue..... : Jun. 23, 2022

Total number of pages..... 102

Test Result..... : PASS

Testing Laboratory..... : Shenzhen ZKT Technology Co., Ltd.

Address : 1/F, No. 101, Building B, No. 6, Tangwei Community Industrial Avenue, Fuhai Street, Bao'an District, Shenzhen, China

Applicant's name : Phonex Broadband Corporation dba ReadyNet

Address : 6952 S. High Tech Drive, Suite B Midvale, UT 84047 United States

Manufacturer's name : Phonex Broadband Corporation dba ReadyNet

Address : 6952 S. High Tech Drive, Suite B Midvale, UT 84047 United States

Test specification:

Standard..... : FCC CFR Title 47 Part 15 Subpart C Section 15.407
ANSI C63.10:2013
KDB 789033 D02 v01r02

Test procedure..... : /

Non-standard test method : N/A

Test Report Form No..... : TRF-EL-113_V0**Test Report Form(s) Originator.....** : ZKT Testing**Master TRF** : Dated: 2020-09-18

This device described above has been tested by ZKT, and the test results show that the equipment under test (EUT) is in compliance with the FCC requirements. And it is applicable only to the tested sample identified in the report.

This report shall not be reproduced except in full, without the written approval of ZKT, this document may be altered or revised by ZKT, personal only, and shall be noted in the revision of the document.

Product name..... : GSX1204 WIRELESS LTE ROUTER

Trademark : ReadyNet

Model/Type reference..... : GSX1204

Ratings..... : DC 12V from Adapter

Testing procedure and testing location:

Testing Laboratory.....: Shenzhen ZKT Technology Co., Ltd.
Address.....: 1/F, No. 101, Building B, No. 6, Tangwei Community
Industrial Avenue, Fuhai Street, Bao'an District,
Shenzhen, China

Tested by (name + signature).....: Alen He

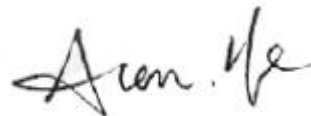

Reviewer (name + signature).....: Joe Liu



Approved (name + signature).....: Lake Xie



Table of Contents

Page

1. VERSION	5
2.SUMMARY OF TEST RESULTS	6
2.1 TEST FACILITY	7
2.2 MEASUREMENT UNCERTAINTY	7
3. GENERAL INFORMATION	8
3.1 GENERAL DESCRIPTION OF EUT	8
3.3 BLOCK DIGRAM SHOWING THE CONFIGURATION OF SYSTEM TESTED	10
3.4 DESCRIPTION OF SUPPORT UNITS(CONDUCTED MODE)	11
3.5 EQUIPMENTS LIST FOR ALL TEST ITEMS	12
4.EMC EMISSION TEST	13
4.1 CONDUCTED EMISSION MEASUREMENT	13
4.1.1 POWER LINE CONDUCTED EMISSION Limits	13
4.1.2 TEST PROCEDURE	13
4.1.3 DEVIATION FROM TEST STANDARD	13
4.1.4 TEST SETUP	14
4.1.5 EUT OPERATING CONDITIONS	14
4.1.6 TEST RESULTS	15
4.2 RADIATED EMISSION MEASUREMENT	17
4.2.1 APPLICABLE STANDARD	17
4.2.2 CONFORMANCE LIMIT	17
4.2.3 MEASURING INSTRUMENTS	17
4.2.4 TEST CONFIGURATION	18
4.2.5 TEST PROCEDURE	19
5.POWER SPECTRAL DENSITY TEST	24
5.1 APPLIED PROCEDURES / LIMIT	26
5.2 TEST PROCEDURE	27
5.3 DEVIATION FROM STANDARD	27
5.4 TEST SETUP	27
5.5 EUT OPERATION CONDITIONS	27
5.6 TEST RESULTS	28
6. 26DB & 6DB EMISSION BANDWIDTH	50
6.1 APPLIED PROCEDURES / LIMIT	50
6.2 TEST PROCEDURE	50
6.3 EUT OPERATION CONDITIONS	51
6.4 TEST RESULTS	51
7.MAXIMUM CONDUCTED OUTPUT POWER	73
7.1 PPLIED PROCEDURES / LIMIT	73

Table of Contents	Page
7.2 TEST PROCEDURE	73
7.3 DEVIATION FROM STANDARD	74
7.4 TEST SETUP	74
7.5 EUT OPERATION CONDITIONS	74
7.6 TEST RESULTS	75
8.OUT OF BAND EMISSIONS	76
8.1 APPLICABLE STANDARD	76
8.2 TEST PROCEDURE	76
8.3 DEVIATION FROM STANDARD	76
8.4 TEST SETUP	76
8.5 EUT OPERATION CONDITIONS	76
8.6 TEST RESULTS	77
9.SPURIOUS RF CONDUCTED EMISSIONS	85
9.1 CONFORMANCE LIMIT	85
9.2 MEASURING INSTRUMENTS	85
9.3 TEST SETUP	85
9.4 TEST PROCEDURE	85
9.5 TEST RESULTS	85
10.Frequency Stability Measurement	92
10.1 LIMIT	92
10.2 TEST PROCEDURES	92
10.3 TEST SETUP LAYOUT	92
10.4 EUT OPERATION DURING TEST	92
10.5 TEST RESULTS	92
11.ANTENNA REQUIREMENT	101
12. TEST SETUP PHOTO	102
13. EUT CONSTRUCTIONAL DETAILS	102

1. VERSION

ReportNo.	Version	Description	Approved
ZKT-220616L4103-2	Rev.01	Initial issue of report	Jun. 23, 2022

2.SUMMARY OF TEST RESULTS

Test procedures according to the technical standards:

FCC Part15 (15.407) , Subpart E			
Standard Section	Test Item	Judgment	Remark
15.209(a), 15.407 (b)(1) 15.407 (b)(4) 15.407 (b)(8)	Spurious Radiated Emissions	PASS	
15.207	Conducted Emission	PASS	
15.407 (a)(12) 15.1049	26 dB and 99% Emission Bandwidth	PASS	
15.407(e)	6 dB bandwidth	PASS	
15.407 (a)(1) 15.407 (a)(3)	Maximum Conducted Output Power	PASS	
2.1051, 15.407(b)(1) 15.407(b)(4)	Band Edge	PASS	
15.407 (a)(1) 15.407 (a)(3)	Power Spectral Density	PASS	
2.1051, 15.407(b)	Spurious Emissions at Antenna Terminals	PASS	
15.203	Antenna Requirement	PASS	
15.407 (g)	Frequency Stability	PASS	

NOTE:

(1) "N/A" denotes test is not applicable in this Test Report

2.1 TEST FACILITY

Shenzhen ZKT Technology Co., Ltd.
Add. : 1/F, No. 101, Building B, No. 6, Tangwei Community Industrial Avenue, Fuhai Street, Bao'an District, Shenzhen, China

FCC Test Firm Registration Number: 692225
Designation Number: CN1299
IC Registered No.: 27033

2.2 MEASUREMENT UNCERTAINTY

The reported uncertainty of measurement $y \pm U$, where expanded uncertainty U is based on a standard uncertainty multiplied by a coverage factor of $k=2$, providing a level of confidence of approximately 95%.

No.	Item	Uncertainty
1	3m chamber Radiated spurious emission(30MHz-1GHz)	U=4.3dB
2	3m chamber Radiated spurious emission(1GHz-18GHz)	U=4.5dB
3	3m chamber Radiated spurious emission(18GHz-40GHz)	U=3.34dB
4	Conducted Adjacent channel power	U=1.38dB
5	Conducted output power uncertainty Above 1G	U=1.576dB
6	Conducted output power uncertainty below 1G	U=1.28dB
7	humidity uncertainty	U=5.3%
8	Temperature uncertainty	U=0.59°C
9	Radiated disturbance(30MHz-1000MHz)	U=4.8dB
10	Radiated disturbance(1GHz-6GHz)	U=4.9dB
11	Radiated disturbance(1GHz-18GHz)	U=5.0dB

3. GENERAL INFORMATION

3.1 GENERAL DESCRIPTION OF EUT

Product Name:	GSX1204 WIRELESS LTE ROUTER	
Test Model No.:	GSX1204	
Sample ID:	ZKT220616L4103E-1#	
Serial No.:	N/A	
Model Different.:	N/A	
Product Description	IEEE 802.11 WLAN Mode Supported	<input checked="" type="checkbox"/> 802.11a/n (20MHz channel bandwidth) <input checked="" type="checkbox"/> 802.11n (40MHz channel bandwidth) <input checked="" type="checkbox"/> 802.11ac(80MHz channel bandwidth)
	Data Rate	802.11a: 6,9,12,18,24,36,48,54Mbps; 802.11n(HT20/HT40):MCS0-MCS7; 802.11ac(VHT80):NSS1, MCS0-MCS9
	Modulation	OFDM with BPSK/QPSK/16QAM/64QAM/256QAM for 802.11a/n/ac;
	Operating Frequency Range	<input checked="" type="checkbox"/> 5180-5240MHz for 802.11a/n(HT20)/ac20; 5190-5230MHz for 802.11n(HT40)/ac40; 5210MHz for 802.11 ac80; <input checked="" type="checkbox"/> 5745-5825 MHz for802.11a/n(HT20)/ac20; 5755-5795 MHz for 802.11a/n(HT40)/ac40; 5775MHz for 802.11 ac80;
	Number of Channels	<input checked="" type="checkbox"/> 4 channels for 802.11a/n20/ac20 in the 5180-5240MHz band ; 2 channels for 802.11 n40/ac40 in the 5190-5230 MHz band ; 1 channels for 802.11 ac80 in the 5210MHz band ; <input checked="" type="checkbox"/> 5 channels for 802.11a/n20/ac20 in the 5745-5825MHz band ; 2 channels for 802.11 n40/ac40 in the 5755-5795 MHz band ; 1 channels for 802.11 ac80 in the 5775MHz band ;
Channel List	Please refer to the Note 2.	
Antenna Type:	External Antenna	
Antenna gain:	Ant A:5dBi Ant B:5dBi	
Directional Gain:	$5+10*\log(2)=8.01\text{dBi}$	
Power supply:	DC 12V/2A from Adapter	
Adapter Information:	Manufacturer:DONGGUAN GANGQI ELECTRONIC CO.,LTD Model: GQ24-120200-AU Input: 100-240V~ 50/60Hz 1.0A Max Output:DC 12V/2.0A	

Note:

For a more detailed features description, please refer to the manufacturer's specifications or the User's Manual.

802.11a/n/ac(20MHz) Frequency Channel							
Channel	Frequency (MHz)	Channel	Frequency (MHz)	Channel	Frequency (MHz)	Channel	Frequency (MHz)
36	5180	44	5220	-	-	-	-
40	5200	48	5240	-	-	-	-

802.11n(40MHz) Frequency Channel

802.11n /ac(40MHz)Frequency Channel							
Channel	Frequency (MHz)	Channel	Frequency (MHz)	Channel	Frequency (MHz)	Channel	Frequency (MHz)
38	5190	-	-	-	-	-	-
46	5230	-	-	-	-	-	-

802.11ac(80MHz) Frequency Channel

Channel	Frequency (MHz)
42	5210

802.11a/n/ac(20 MHz) Frequency Channel

Channel	Frequency (MHz)	Channel	Frequency (MHz)	Channel	Frequency (MHz)	Channel	Frequency (MHz)
149	5745	153	5765	157	5785	161	5805
165	5825	-	-	-	-	-	-

802.11n/ac40MHzFrequency Channel

Channel	Frequency (MHz)	Channel	Frequency (MHz)	Channel	Frequency (MHz)
151	5755	159	5795	-	-

802.11ac80MHz Frequency Channel

Channel	Frequency (MHz)
155	5775

3.2 DESCRIPTION OF TEST MODES

Transmitting mode	Keep the EUT in continuously transmitting mode
Remark: During the test, the duty cycle >98%, the test voltage was tuned from 85% to 115% of the nominal rated supply voltage, and found that the worst case was under the nominal rated supply condition. So the report just shows that condition's data.	

Pretest Mode	Description
Mode 1	802.11a / ac 20/n 20 CH36/ CH40/ CH 48 802.11a / ac 20/n 20 CH149/ CH157/ CH 165
Mode 2	802.11ac / n 40 CH38/ CH 46 802.11ac / n 40 CH151/ CH 159
Mode 3	802.11 ac80 CH 42/CH 155

Note:

(1) The measurements are performed at all Bit Rate of Transmitter, the worst data was reported.

Test Software	QATool_Dbg.exe
Powerlevelsetup	<10dBm

3.3 BLOCK DIAGRAM SHOWING THE CONFIGURATION OF SYSTEM TESTED

Conducted Emission

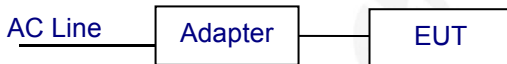

Radiated Emission



Conducted Spurious



3.4 DESCRIPTION OF SUPPORT UNITS(CONDUCTED MODE)

The EUT has been tested as an independent unit together with other necessary accessories or support units. The following support units or accessories were used to form a representative test configuration during the tests.

Item	Equipment	Mfr/Brand	Model/Type No.	Series No.	Note
E-1	GSX1204 WIRELESS LTE ROUTER	ReadyNet	GSX1204	N/A	EUT
AE-1	Notebook	lenovo	B40-80	MP07F6JD	AE

Item	Shielded Type	Ferrite Core	Length	Note

Note:

- (1) The support equipment was authorized by Declaration of Confirmation.
- (2) For detachable type I/O cable should be specified the length in cm in 『Length』 column.

3.5 EQUIPMENTS LIST FOR ALL TEST ITEMS
Radiation & RF Conducted Test equipment

Item	Equipment	Manufacturer	Type No.	Serial No.	Last calibration	Calibrated until
1	Spectrum Analyzer (9kHz-26.5GHz)	KEYSIGHT	9020A	MY45109572	Sep. 21, 2021	Sep. 20, 2022
2	Spectrum Analyzer (1GHz-40GHz)	Agilent	E4446A	100363	Sep. 21, 2021	Sep. 20, 2022
3	Test Receiver (9kHz-7GHz)	R&S	ESC17	101169	Sep. 21, 2021	Sep. 20, 2022
4	Bilog Antenna (30MHz-1400MHz)	Schwarzbeck	VULB9168	00877	Sep. 21, 2021	Sep. 20, 2022
5	Horn Antenna (1GHz-18GHz)	SCHWARZBEC K	BBHA9120D	1541	Sep. 21, 2021	Sep. 20, 2022
6	Horn Antenna (18GHz-40GHz)	A.H. System	SAS-574	588	Sep. 21, 2021	Sep. 20, 2022
7	Amplifier (30-1000MHz)	EM Electronics	EM330 Amplifier	N/A	Sep. 21, 2021	Sep. 20, 2022
8	Amplifier (1GHz-40GHz)	全聚达	DLE-161	097	Sep. 21, 2021	Sep. 20, 2022
9	Loop Antenna (9kHz-30MHz)	SCHWARZBEC K	FMZB1519B	014	Sep. 21, 2021	Sep. 20, 2022
10	RF cables1 (9kHz-30MHz)	N/A	9kHz-30MHz	N/A	Sep. 21, 2021	Sep. 20, 2022
11	RF cables2 (30MHz-1GHz)	N/A	30MHz-1GHz	N/A	Sep. 21, 2021	Sep. 20, 2022
12	RF cables3 (1GHz-40GHz)	N/A	1GHz-40GHz	N/A	Sep. 21, 2021	Sep. 20, 2022
13	CMW500 Test	R&S	CMW500	106504	Sep. 21, 2021	Sep. 20, 2022
14	ESG Signal Generator	Agilent	E4421B	GB40051203	Sep. 21, 2021	Sep. 20, 2022
15	Signal Generator	Agilent	N5182A	MY47420215	Sep. 21, 2021	Sep. 20, 2022
16	Power Meter	Anritsu	ML2495A	N/A	Sep. 21, 2021	Sep. 20, 2022
17	D.C. Power Supply	LongWei	TPR-6405D	\	\	\
18	Software	Audix	E3	6.101223a	\	\

Conduction Test equipment

Item	Kind of Equipment	Manufacturer	Type No.	Serial No.	Last calibration	Calibrated until
1	LISN	R&S	ENV216	101471	Sep. 21, 2021	Sep. 20, 2022
2	LISN	CYBERTEK	EM5040A	E185040014 g	Sep. 21, 2021	Sep. 20, 2022
3	Test Cable	N/A	C01	N/A	Sep. 21, 2021	Sep. 20, 2022
4	Test Cable	N/A	C02	N/A	Sep. 21, 2021	Sep. 20, 2022
5	EMI Test Receiver	R&S	ESRP3	101946	Sep. 21, 2021	Sep. 20, 2022
6	Absorbing Clamp	DZ	ZN23201	N/A	Sep. 21, 2021	Sep. 20, 2022
7	Power Meter	Anritsu	ML2495A	N/A	Sep. 21, 2021	Sep. 20, 2022
8	Software	Audix	E3	6.101223a	\	\

4. EMC EMISSION TEST

4.1 CONDUCTED EMISSION MEASUREMENT

Test Requirement:	FCC Part15 C Section 15.207
Test Method:	ANSI C63.10:2013
Test Frequency Range:	150KHz to 30MHz
Receiver setup:	RBW=9KHz, VBW=30KHz, Sweep time=auto

4.1.1 POWER LINE CONDUCTED EMISSION Limits

FREQUENCY (MHz)	Limit (dBuV)		Standard
	Quasi-peak	Average	
0.15 -0.5	66 - 56 *	56 - 46 *	FCC
0.50 -5.0	56.00	46.00	FCC
5.0 -30.0	60.00	50.00	FCC

Note:

(1) *Decreases with the logarithm of the frequency.

4.1.2 TEST PROCEDURE

- a. The EUT was placed 0.8 meters from the horizontal ground plane with EUT being connected to the power mains through a line impedance stabilization network (LISN). All other support equipments powered from additional LISN(s). The LISN provide 50 Ohm/ 50uH of coupling impedance for the measuring instrument.
- b. Interconnecting cables that hang closer than 40 cm to the ground plane shall be folded back and forth in the center forming a bundle 30 to 40 cm long.
- c. I/O cables that are not connected to a peripheral shall be bundled in the center. The end of the cable may be terminated, if required, using the correct terminating impedance. The overall length shall not exceed 1 m.
- d. LISN at least 80 cm from nearest part of EUT chassis.
- e. For the actual test configuration, please refer to the related Item –EUT Test Photos.

4.1.3 DEVIATION FROM TEST STANDARD

No deviation

4.1.4 TEST SETUP

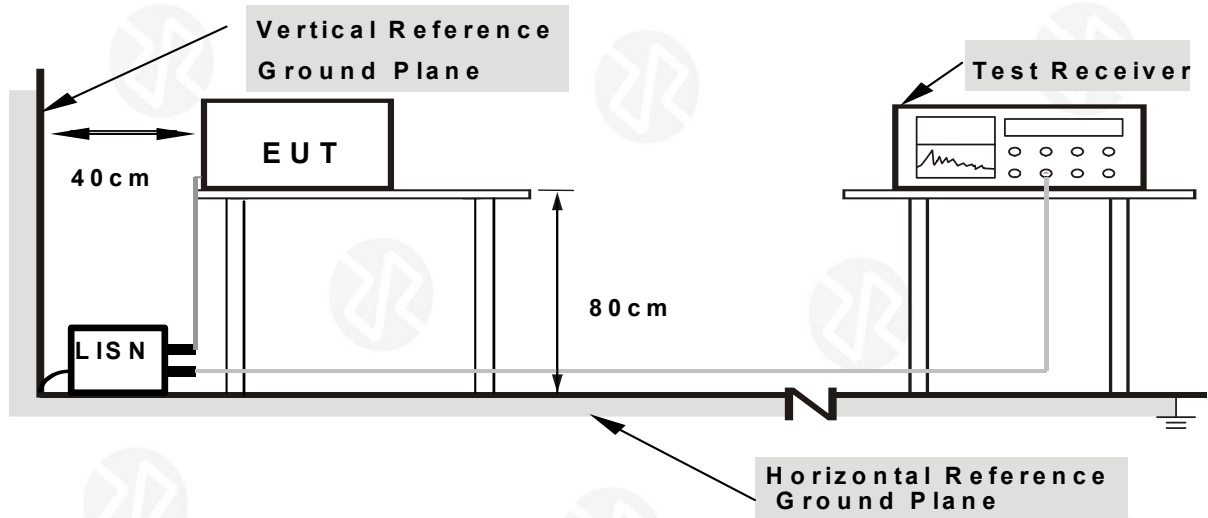

Note: 1. Support units were connected to second LISN.

2. Both of LISNs (AMN) are 80 cm from EUT and at least 80 cm from other units and other metal planes

4.1.5 EUT OPERATING CONDITIONS

The EUT was configured for testing in a typical fashion (as a customer would normally use it). The EUT has been programmed to continuously transmit during test. This operating condition was tested and used to collect the included data.

We pretest AC 120V and AC 230V, the worst voltage was AC 120V and the data recording in the report.

4.1.6 TEST RESULTS

Temperature :	26°C	Relative Humidity:	54%
Pressure :	101kPa	Phase :	L
Test Voltage :	AC 120V/60Hz	Test Model:	GSX1204

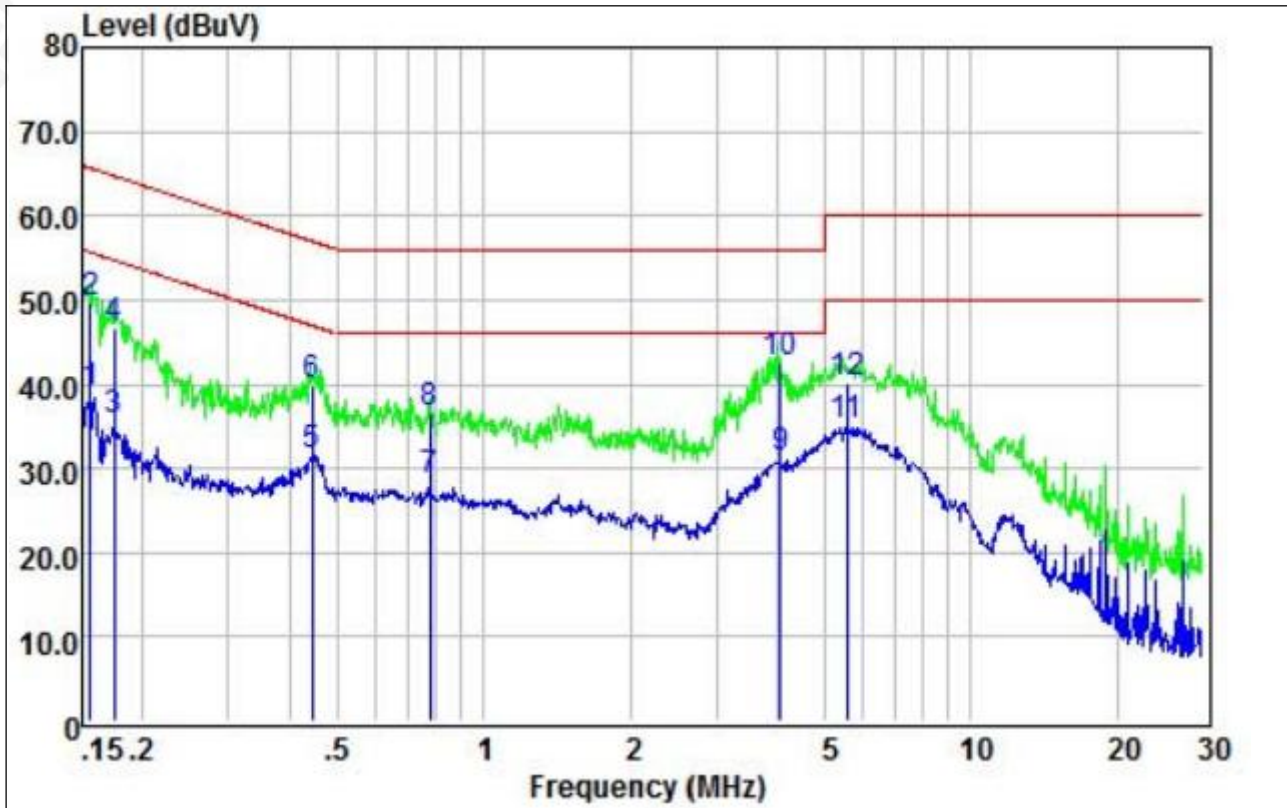

	Read Freq	Read Level	LISN Factor	Cable Loss	Level	Limit Line	Over Limit	Remark
	MHz	dBuV	dB	dB	dBuV	dBuV	dB	
1	0.16	29.29	9.63	0.05	38.97	55.69	-16.72	Average
2	0.16	40.01	9.63	0.05	49.69	65.69	-16.00	QP
3	0.17	25.93	9.64	0.05	35.62	54.77	-19.15	Average
4	0.17	37.00	9.64	0.05	46.69	64.77	-18.08	QP
5	0.44	21.81	9.68	0.05	31.54	46.98	-15.44	Average
6	0.44	29.98	9.68	0.05	39.71	56.98	-17.27	QP
7	0.78	18.75	9.63	0.05	28.43	46.00	-17.57	Average
8	0.78	27.03	9.63	0.05	36.71	56.00	-19.29	QP
9	4.05	21.55	9.57	0.06	31.18	46.00	-14.82	Average
10	4.05	32.96	9.57	0.06	42.59	56.00	-13.41	QP
11	5.56	25.32	9.60	0.07	34.99	50.00	-15.01	Average
12	5.56	30.60	9.60	0.07	40.27	60.00	-19.73	QP

Notes:

1. An initial pre-scan was performed on the line and neutral lines with peak detector.
2. Quasi-Peak and Average measurement were performed at the frequencies with maximized peak emission.
3. Measurement Level = Reading level + Correct Factor

Temperature :	26°C	Relative Humidity:	54%
Pressure :	101kPa	Phase :	N
Test Voltage :	AC 120V/60Hz	Test Model:	GSX1204

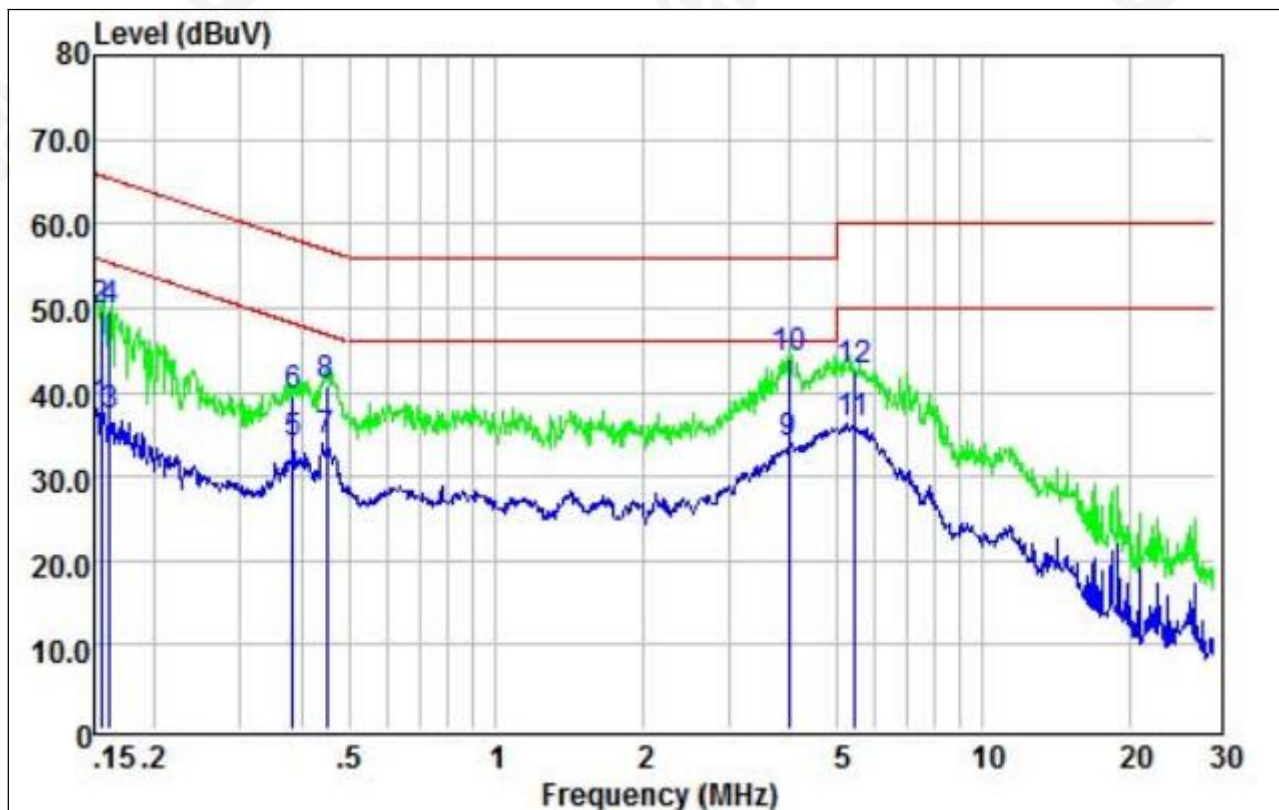

	Read Freq	Read Level	LISN Factor	Cable Loss	Level	Limit Line	Over Limit	Remark
	MHz	dBuV	dB	dB	dBuV	dBuV	dB	
1	0.15	28.48	9.60	0.05	38.13	55.74	-17.61	Average
2	0.15	40.04	9.60	0.05	49.69	65.74	-16.05	QP
3	0.16	27.52	9.59	0.05	37.16	55.38	-18.22	Average
4	0.16	39.93	9.59	0.05	49.57	65.38	-15.81	QP
5	0.38	24.18	9.61	0.05	33.84	48.21	-14.37	Average
6	0.38	30.03	9.61	0.05	39.69	58.21	-18.52	QP
7	0.45	24.65	9.63	0.05	34.33	46.85	-12.52	Average
8	0.45	31.01	9.63	0.05	40.69	56.85	-16.16	QP
9	3.99	24.05	9.66	0.06	33.77	46.00	-12.23	Average
10	3.99	34.44	9.66	0.06	44.16	56.00	-11.84	QP
11	5.42	26.68	9.67	0.06	36.41	50.00	-13.59	Average
12	5.42	32.69	9.67	0.06	42.42	60.00	-17.58	QP

Notes:

1. An initial pre-scan was performed on the line and neutral lines with peak detector.
2. Quasi-Peak and Average measurement were performed at the frequencies with maximized peak emission.
3. Measurement Level = Reading level + Correct Factor

4.2 RADIATED EMISSION MEASUREMENT

4.2.1 APPLICABLE STANDARD

According to FCC Part 15.407(d) and 15.209

4.2.2 CONFORMANCE LIMIT

According to FCC Part 15.407(b)(7): radiated emissions which fall in the restricted bands, as defined in §15.205(a), must also comply with the radiated emission limits specified in §15.209(a) (see §15.205(c)).

According to FCC Part 15.205, Restricted bands

MHz	MHz	MHz	GHz
0.090-0.110	16.42-16.423	399.9-410	4.5-5.15
10.495-0.505	16.69475-16.69525	608-614	5.35-5.46
2.1735-2.1905	16.80425-16.80475	960-1240	7.25-7.75
4.125-4.128	25.5-25.67	1300-1427	8.025-8.5
4.17725-4.17775	37.5-38.25	1435-1626.5	9.0-9.2
4.20725-4.20775	73-74.6	1645.5-1646.5	9.3-9.5
6.215-6.218	74.8-75.2	1660-1710	10.6-12.7
6.26775-6.26825	123-138	2200-2300	14.47-14.5
8.291-8.294	149.9-150.05	2310-2390	15.35-16.2
8.362-8.366	156.52475-156.52525	2483.5-2500	17.7-21.4
8.37625-8.38675	156.7-156.9	2690-2900	22.01-23.12
8.41425-8.41475	162.0125-167.17	3260-3267	23.6-24.0
12.29-12.293	167.72-173.2	3332-3339	31.2-31.8
12.51975-12.52025	240-285	3345.8-3358	36.43-36.5
12.57675-12.57725	322-335.4	3600-4400	(2)
13.36-13.41			

20dBc in any 100 kHz bandwidth outside the operating frequency band. In case the emission fall within the restricted band specified on 15.205(a), then the 15.209(a) limit in the table below has to be followed.

Restricted Frequency(MHz)	Field Strength (μV/m)	Field Strength (dBμV/m)	Measurement Distance
0.009~0.490	2400/F(KHz)	20 log (uV/m)	300
0.490~1.705	2400/F(KHz)	20 log (uV/m)	30
1.705~30.0	30	29.5	30
30-88	100	40	3
88-216	150	43.5	3
216-960	200	46	3
Above 960	500	54	3

Limits of Radiated Emission Measurement(Above 1000MHz)

Frequency(MHz)	Class B (dBuV/m) (at 3M)	
	PEAK	AVERAGE
Above 1000	74	54

- Remark :1. Emission level in dBuV/m=20 log (uV/m)
 2. Measurement was performed at an antenna to the closed point of EUT distance of meters.
 3. Distance extrapolation factor =40log(Specific distance/ test distance)(dB);
 Limit line=Specific limits(dBuV) + distance extrapolation factor.

4.2.3 MEASURING INSTRUMENTS

The Measuring equipment is listed in the section 6.3 of this test report.

4.2.4 TEST CONFIGURATION

1. For radiated emissions below 30MHz

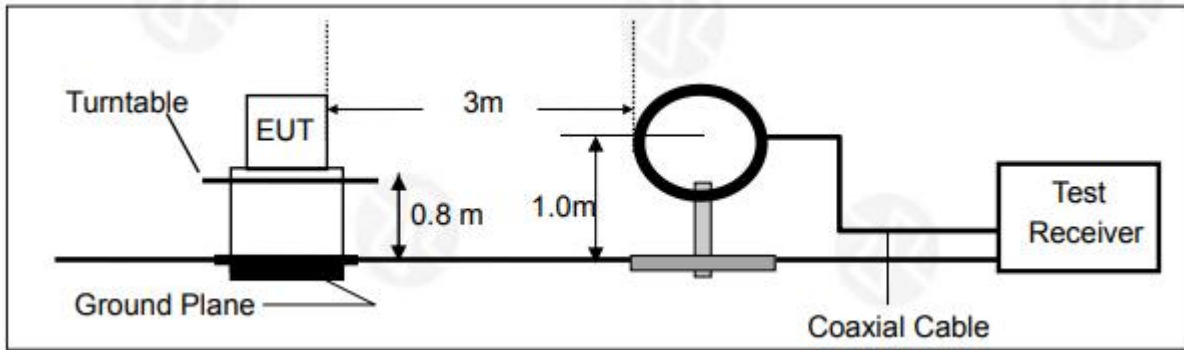

2. For radiated emissions from 30MHz to 1000MHz

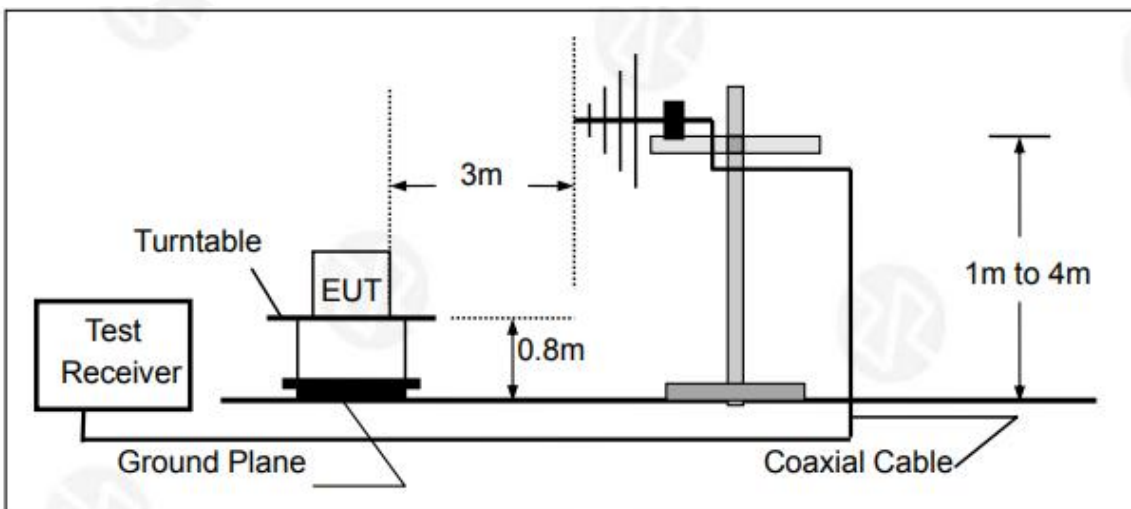

3. Radiated Emission Test-Up Frequency Above 1GHz

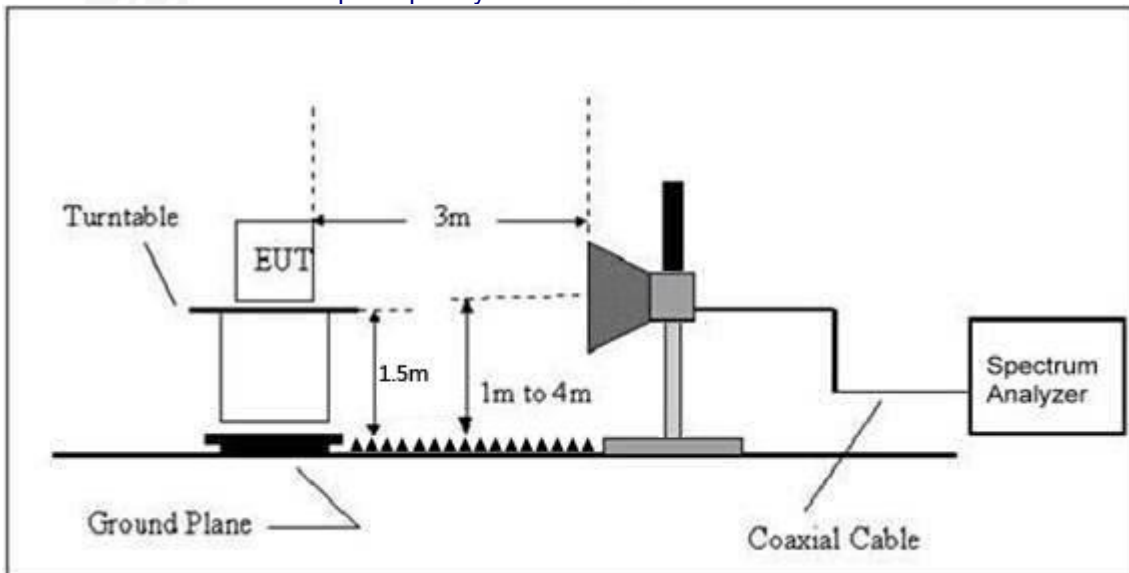

4.2.5 TEST PROCEDURE

The test site semi-anechoic chamber has met the requirement of NSA tolerance 4 dB according to the standards: ANSI C63.10-2013. The test distance is 3m. The setup is according to the requirements in Section 13.1.4.1 of ANSI C63.10-2013 and CAN/CSA-CEI/IEC CISPR 22.

This test is required for any spurious emission that falls in a Restricted Band, as defined in Section 15.205. It must be performed with the highest gain of each type of antenna proposed for use with the EUT.

Use the following spectrum analyzer settings:

Spectrum Parameter	Setting
Attenuation	Auto
Start Frequency	1000 MHz
Stop Frequency	10th carrier harmonic
RB / VB (emission in restricted band)	1 MHz / 1 MHz for Peak, 1 MHz / 1/T for Average

Receiver Parameter	Setting
Attenuation	Auto
Start ~ Stop Frequency	9kHz~150kHz / RB 200Hz for QP
Start ~ Stop Frequency	150kHz~30MHz / RB 9kHz for QP
Start ~ Stop Frequency	30MHz~1000MHz / RB 120kHz for QP

- The measuring distance of at 3 m shall be used for measurements at frequency up to 1GHz. For frequencies above 1GHz, any suitable measuring distance may be used.
- The EUT was placed on the top of a rotating table 0.8 m for below 1GHz and 1.5m for above 1GHz the ground at a 3 meter. The table was rotated 360 degrees to determine the position of the highest radiation.
- The height of the equipment or of the substitution antenna shall be 0.8 m for below 1GHz and 1.5m for above 1GHz; the height of the test antenna shall vary between 1 m to 4 m. Both horizontal and vertical polarizations of the antenna are set to make the measurement.
- The initial step in collecting conducted emission data is a spectrum analyzer peak detector mode pre-scanning the measurement frequency range. Significant peaks are then marked and then Quasi Peak detector mode re-measured.
- If the Peak Mode measured value compliance with and lower than Quasi Peak Mode Limit, the EUT shall be deemed to meet QP Limits and then no additional QP Mode measurement performed.
- For the actual test configuration, please refer to the related Item –EUT Test Photos.

Note:

Both horizontal and vertical antenna polarities were tested and performed pretest to three orthogonal axis. The worst case emissions were reported

During the radiated emission test, the Spectrum Analyzer was set with the following configurations:

Frequency Band (MHz)	Function	Resolution bandwidth	Video Bandwidth
30 to 1000	QP	120 kHz	300 kHz
Above 1000	Peak	1 MHz	1 MHz
	Average	1 MHz	1/T

Note: for the frequency ranges below 30 MHz, a narrower RBW is used for these ranges but the measured value should add a RBW correction factor (RBWCF) where $RBWCF [dB] = 10 \cdot \lg(100 [kHz]/\text{narrower RBW [kHz]})$, the narrower RBW is 1 kHz and RBWCF is 20 dB for the frequency 9 kHz to 150 kHz, and the narrower RBW is 10 kHz and RBWCF is 10 dB for the frequency 150 kHz to 30 MHz.

4.2.6 TEST RESULT(Between 9KHz – 30MHz)

The emission from 9 kHz to 30MHz was pre-tested and found the result was 20dB lower than the limit, and according to 15.31(o) & RSS-Gen 6.13, the test result no need to reported.

Between 30MHz – 1GHz

Temperature:	26°C	Relative Humidity:	54%
Pressure:	101 kPa	Polarization:	Horizontal
Test Voltage:	AC 120V/60Hz	Test Model:	GSX1204

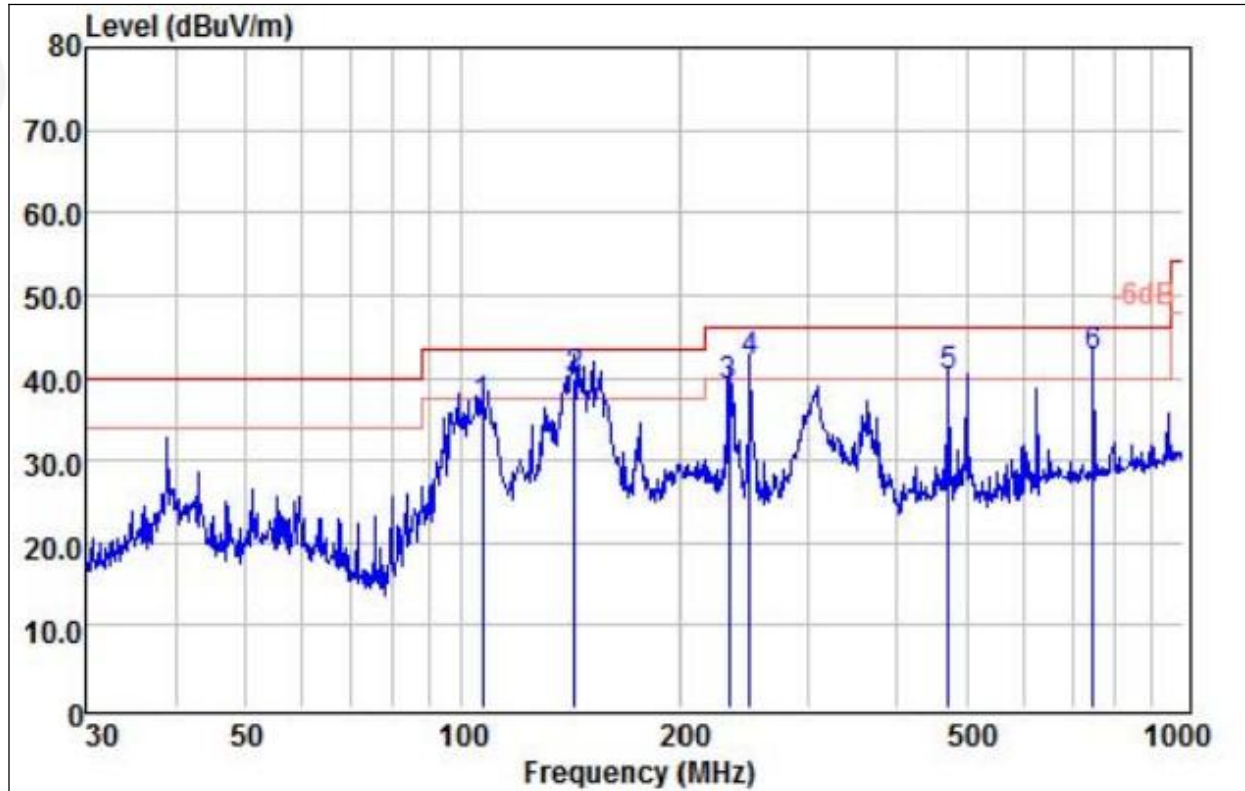

	ReadAntenna	Cable	Limit	Over			
Freq	Level	Factor	Loss	Level	Line	Limit	Remark
MHz	dBuV	dB/m	dB	dBuV/m	dBuV/m	dB	
1	106.76	23.74	12.08	0.83	36.65	43.50	-6.85 QP
2 !	143.33	25.30	13.70	0.85	39.85	43.50	-3.65 QP
3	234.17	27.59	10.64	0.87	39.10	46.00	-6.90 QP
4 !	250.30	29.60	11.51	0.86	41.97	46.00	-4.03 QP
5 !	472.18	21.64	17.00	1.56	40.20	46.00	-5.80 QP
6 !	750.11	18.81	21.60	2.08	42.49	46.00	-3.51 QP

Temperature:	26°C	Relative Humidity:	54%
Pressure:	101kPa	Polarization:	Vertical
Test Voltage:	AC 120V/60Hz	Test Model:	GSX1204

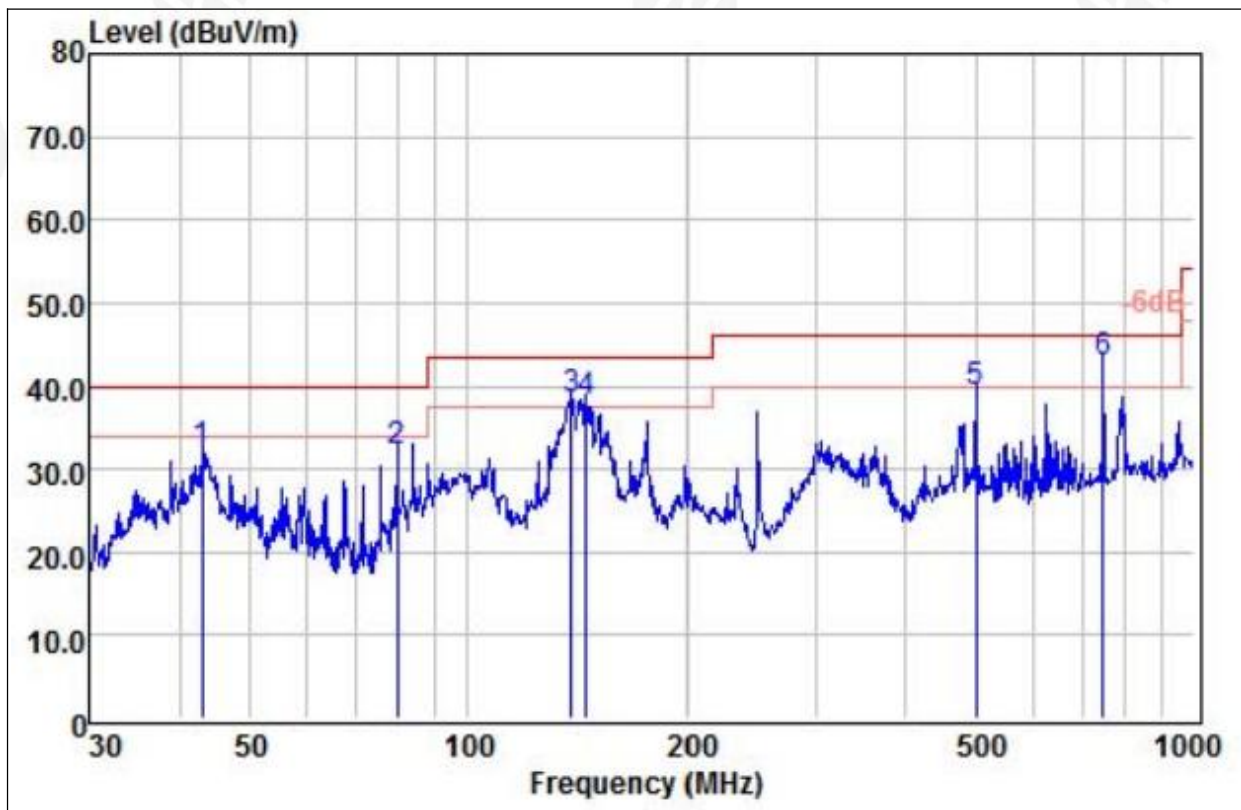

	Read	Antenna	Cable	Limit	Over		
Freq	Level	Factor	Loss	Line	Limit	Remark	
MHz	dBuV	dB/m	dB	dBuV/m	dBuV/m	dB	
1	42.90	20.34	11.49	0.27	32.10	40.00	-7.90 QP
2	79.80	22.39	8.73	0.87	31.99	40.00	-8.01 QP
3 !	138.87	24.00	13.46	0.85	38.31	43.50	-5.19 QP
4 !	145.35	23.42	13.82	0.85	38.09	43.50	-5.41 QP
5	501.18	19.73	17.82	1.65	39.20	46.00	-6.80 QP
6 !	750.11	19.16	21.60	2.08	42.84	46.00	-3.16 QP

Remarks:

1. Final Level = Receiver Read level + Antenna Factor + Cable Loss – Preamplifier Factor
2. The emission levels of other frequencies are very lower than the limit and not show in test report.
3. The test data shows only the worst case 802.11a mode

Record the worst test data for Antenna B in report.
 Between 1GHz – 40GHz

Temperature :	26°C	Relative Humidity :	54%
Pressure :	1010 hPa	Test Voltage :	AC 120V/60Hz
Test Mode :	5.2G TX- 802.11a		

802.11a

Polar (H/V)	Frequency	Meter Reading	Pre-amplifier	Cable Loss	Antenna Factor	Emission Level	Limits	Margin	Detect or Type
	(MHz)	(dBuV)	(dB)	(dB)	(dB)	(dBuV/m)	(dBuV/m)	(dB)	
Low Channel:5180MHz									
V	10360.00	56.82	30.55	5.77	24.66	56.7	74.00	-17.3	PK
V	10360.00	46.38	30.55	5.77	24.66	46.26	54.00	-7.74	AV
V	15540.00	54.59	30.33	6.32	24.55	55.13	74.00	-18.87	PK
V	15540.00	44.53	30.33	6.32	24.55	45.07	54.00	-8.93	AV
V	20720.00	52.47	30.85	7.45	24.69	53.76	74.00	-20.24	PK
V	20720.00	/	30.85	7.45	24.69	/	54.00	/	AV
V	25900.00	51.39	31.02	8.99	25.57	54.93	74.00	-19.07	PK
V	25900.00	/	31.02	8.99	25.57	/	54.00	/	AV
H	10360.00	56.78	30.55	5.77	24.66	56.66	74.00	-17.34	PK
H	10360.00	46.38	30.55	5.77	24.66	46.26	54.00	-7.74	AV
H	15540.00	55.06	30.33	6.32	24.55	55.6	74.00	-18.4	PK
H	15540.00	45.32	30.33	6.32	24.55	45.86	54.00	-8.14	AV
H	20720.00	52.46	30.85	7.45	24.69	53.75	74.00	-20.25	PK
H	20720.00	/	30.85	7.45	24.69	/	54.00	/	AV
H	25900.00	51.08	31.02	8.99	25.57	54.62	74.00	-19.38	PK
H	25900.00	/	31.02	8.99	25.57	/	54.00	/	AV

Polar (H/V)	Frequency	Meter Reading	Pre-amplifier	Cable Loss	Antenna Factor	Emission Level	Limits	Margin	Detector Type
	(MHz)	(dBuV)	(dB)	(dB)	(dB)	(dBuV/m)	(dBuV/m)	(dB)	
Middle Channel:5200MHz									
V	10400.00	56.32	30.55	5.77	24.66	56.2	74.00	-17.8	PK
V	10400.00	46.55	30.55	5.77	24.66	46.43	54.00	-7.57	AV
V	15600.00	54.83	30.33	6.32	24.55	55.37	74.00	-18.63	PK
V	15600.00	44.39	30.33	6.32	24.55	44.93	54.00	-9.07	AV
V	20800.00	52.67	30.85	7.45	24.69	53.96	74.00	-20.04	PK
V	20800.00	/	30.85	7.45	24.69	/	54.00	/	AV
V	26000.00	51.03	31.02	8.99	25.57	54.57	74.00	-19.43	PK
V	26000.00	/	31.02	8.99	25.57	/	54.00	/	AV
H	10400.00	56.47	30.55	5.77	24.66	56.35	74.00	-17.65	PK
H	10400.00	46.93	30.55	5.77	24.66	46.81	54.00	-7.19	AV
H	15600.00	54.36	30.33	6.32	24.55	54.9	74.00	-19.1	PK
H	15600.00	44.19	30.33	6.32	24.55	44.73	54.00	-9.27	AV
H	20800.00	52.63	30.85	7.45	24.69	53.92	74.00	-20.08	PK
H	20800.00	/	30.85	7.45	24.69	/	54.00	/	AV
H	26000.00	50.98	31.02	8.99	25.57	54.52	74.00	-19.48	PK
H	26000.00	/	31.02	8.99	25.57	/	54.00	/	AV

Polar (H/V)	Frequency	Meter Reading	Pre-ampli fier	Cable Loss	Antenna Factor	Emission Level	Limits	Margin	Detect or Type
	(MHz)	(dBuV)	(dB)	(dB)	(dB)	(dBuV/m)	(dBuV/ m)	(dB)	
High Channel:5240MHz									
V	10480.00	56.37	30.55	5.77	24.66	56.25	74.00	-17.75	PK
V	10480.00	46.72	30.55	5.77	24.66	46.6	54.00	-7.4	AV
V	15720.00	54.85	30.33	6.32	24.55	55.39	74.00	-18.61	PK
V	15720.00	44.19	30.33	6.32	24.55	44.73	54.00	-9.27	AV
V	20960.00	52.67	30.85	7.45	24.69	53.96	74.00	-20.04	PK
V	20960.00	/	30.85	7.45	24.69	/	54.00	/	AV
V	26200.00	51.43	31.02	8.99	25.57	54.97	74.00	-19.03	PK
V	26200.00	/	31.02	8.99	25.57	/	54.00	/	AV
H	10480.00	55.89	30.55	5.77	24.66	55.77	74.00	-18.23	PK
H	10480.00	45.66	30.55	5.77	24.66	45.54	54.00	-8.46	AV
H	15720.00	54.37	30.33	6.32	24.55	54.91	74.00	-19.09	PK
H	15720.00	44.56	30.33	6.32	24.55	45.1	54.00	-8.9	AV
H	20960.00	52.36	30.85	7.45	24.69	53.65	74.00	-20.35	PK
H	20960.00	/	30.85	7.45	24.69	/	54.00	/	AV
H	26200.00	50.27	31.02	8.99	25.57	53.81	74.00	-20.19	PK
H	26200.00	/	31.02	8.99	25.57	/	54.00	/	AV

Remark:

1. Emission Level = Meter Reading + Antenna Factor + Cable Loss – Pre-amplifier,

Margin= Emission Level - Limit

2. If peak below the average limit, the average emission was no test.

3. The amplitude of spurious emissions which are attenuated by more than 20dB below the permissible value has no need to be reported.

4. The worst mode is 802.11a, only the worst data is recorded.

Temperature :	26℃	Relative Humidity :	54%
Pressure :	1010 hPa	Test Voltage :	AC 120V/60Hz
Test Mode :	5.8G TX- 802.11a		

802.11a

Polar (H/V)	Frequency	Meter Reading	Pre-amplifier	Cable Loss	Antenna Factor	Emission Level	Limits	Margin	Detect or Type
	(MHz)	(dBuV)	(dB)	(dB)	(dB)	(dBuV/m)	(dBuV/m)	(dB)	
Low Channel:5745MHz									
V	11490.00	55.26	30.55	5.77	24.66	55.14	74	-18.86	PK
V	11490.00	45.54	30.55	5.77	24.66	45.42	54	-8.58	AV
V	17235.00	54.83	30.33	6.32	24.55	55.37	74	-18.63	PK
V	17235.00	43.96	30.33	6.32	24.55	44.5	54	-9.5	AV
V	22980.00	52.33	30.85	7.45	24.69	53.62	74	-20.38	PK
V	22980.00	/	30.85	7.45	24.69	/	54	/	AV
V	28725.00	50.32	31.02	8.99	25.57	53.86	74	-20.14	PK
V	28725.00	/	31.02	8.99	25.57	/	54	/	AV
H	11490.00	56.33	30.55	5.77	24.66	56.21	74	-17.79	PK
H	11490.00	46.82	30.55	5.77	24.66	46.7	54	-7.3	AV
H	17235.00	54.13	30.33	6.32	24.55	54.67	74	-19.33	PK
H	17235.00	44.89	30.33	6.32	24.55	45.43	54	-8.57	AV
H	22980.00	52.13	30.85	7.45	24.69	53.42	74	-20.58	PK
H	22980.00	/	30.85	7.45	24.69	/	54	/	AV
H	28725.00	50.27	31.02	8.99	25.57	53.81	74	-20.19	PK
H	28725.00	/	31.02	8.99	25.57	/	54	/	AV

Polar (H/V)	Frequency	Meter Reading	Pre-amplifier	Cable Loss	Antenna Factor	Emission Level	Limits	Margin	Detect or Type
	(MHz)	(dBuV)	(dB)	(dB)	(dB)	(dBuV/m)	(dBuV/m)	(dB)	
Middle Channel:5785MHz									
V	11570.00	56.25	30.55	5.77	24.66	56.13	74	-17.87	PK
V	11570.00	46.34	30.55	5.77	24.66	46.22	54	-7.78	AV
V	17355.00	54.86	30.33	6.32	24.55	55.4	74	-18.6	PK
V	17355.00	44.38	30.33	6.32	24.55	44.92	54	-9.08	AV
V	23140.00	51.79	30.85	7.45	24.69	53.08	74	-20.92	PK
V	23140.00	/	30.85	7.45	24.69	/	54	/	AV
V	28925.00	49.66	31.02	8.99	25.57	53.2	74	-20.8	PK
V	28925.00	/	31.02	8.99	25.57	/	54	/	AV
H	11570.00	56.47	30.55	5.77	24.66	56.35	74	-17.65	PK
H	11570.00	46.29	30.55	5.77	24.66	46.17	54	-7.83	AV
H	17355.00	54.63	30.33	6.32	24.55	55.17	74	-18.83	PK
H	17355.00	44.52	30.33	6.32	24.55	45.06	54	-8.94	AV
H	23140.00	52.33	30.85	7.45	24.69	53.62	74	-20.38	PK
H	23140.00	/	30.85	7.45	24.69	/	54	/	AV
H	28925.00	50.83	31.02	8.99	25.57	54.37	74	-19.63	PK
H	28925.00	/	31.02	8.99	25.57	/	54	/	AV

Polar (H/V)	Frequency	Meter Reading	Pre-amplifier	Cable Loss	Antenna Factor	Emission Level	Limits	Margin	Detect or Type
	(MHz)	(dBuV)	(dB)	(dB)	(dB)	(dBuV/m)	(dBuV/m)	(dB)	
High Channel:5825MHz									
V	11650.00	56.55	30.55	5.77	24.66	56.43	74	-17.57	PK
V	11650.00	46.85	30.55	5.77	24.66	46.73	54	-7.27	AV
V	17475.00	54.69	30.33	6.32	24.55	55.23	74	-18.77	PK
V	17475.00	44.71	30.33	6.32	24.55	45.25	54	-8.75	AV
V	23300.00	51.39	30.85	7.45	24.69	52.68	74	-21.32	PK
V	23300.00	/	30.85	7.45	24.69	/	54	/	AV
V	29125.00	49.66	31.02	8.99	25.57	53.2	74	-20.8	PK
V	29125.00	/	31.02	8.99	25.57	/	54	/	AV
H	11650.00	56.88	30.55	5.77	24.66	56.76	74	-17.24	PK
H	11650.00	46.74	30.55	5.77	24.66	46.62	54	-7.38	AV
H	17475.00	54.26	30.33	6.32	24.55	54.8	74	-19.2	PK
H	17475.00	44.35	30.33	6.32	24.55	44.89	54	-9.11	AV
H	23300.00	52.34	30.85	7.45	24.69	53.63	74	-20.37	PK
H	23300.00	/	30.85	7.45	24.69	/	54	/	AV
H	29125.00	51.08	31.02	8.99	25.57	54.62	74	-19.38	PK
H	29125.00	/	31.02	8.99	25.57	/	54	/	AV

Remark:

1. Emission Level = Meter Reading + Antenna Factor + Cable Loss – Pre-amplifier, Margin= Emission Level - Limit
2. If peak below the average limit, the average emission was no test.
3. The amplitude of spurious emissions which are attenuated by more than 20dB below the permissible value has no need to be reported.
4. The worst mode is 802.11a, only the worst data is recorded.

5. POWER SPECTRAL DENSITY TEST

5.1 APPLIED PROCEDURES / LIMIT

According to FCC §15.407(3)

Power limits:

(1) For the band 5.15-5.25 GHz.

(i) For an outdoor access point operating in the band 5.15-5.25 GHz, the maximum power spectral density shall not exceed 17 dBm in any 1 megahertz band. If transmitting antennas of directional gain greater than 6 dBi are used, both the maximum conducted output power and the maximum power spectral density shall be reduced by the amount in dB that the directional gain of the antenna exceeds 6 dBi. The maximum e.i.r.p. at any elevation angle above 30 degrees as measured from the horizon must not exceed 125 mW (21 dBm).

(ii) For an indoor access point operating in the band 5.15-5.25 GHz, the maximum power spectral density shall not exceed 17 dBm in any 1 megahertz band. If transmitting antennas of directional gain greater than 6 dBi are used, both the maximum conducted output power and the maximum power spectral density shall be reduced by the amount in dB that the directional gain of the antenna exceeds 6 dBi.

(iii) For fixed point-to-point access points operating in the band 5.15-5.25 GHz, the maximum power spectral density shall not exceed 17 dBm in any 1 megahertz band. Fixed point-to-point U-NII devices may employ antennas with directional gain up to 23 dBi without any corresponding reduction in the maximum conducted output power or maximum power spectral density. For fixed point-to-point transmitters that employ a directional antenna gain greater than 23 dBi, a 1 dB reduction in maximum conducted output power and maximum power spectral density is required for each 1 dB of antenna gain in excess of 23 dBi. Fixed, point-to-point operations exclude the use of point-to-multipoint systems, omnidirectional applications, and multiple collocated transmitters transmitting the same information. The operator of the U-NII device, or if the equipment is professionally installed, the installer, is responsible for ensuring that systems employing high gain directional antennas are used exclusively for fixed, point-to-point operations.

(iv) For client devices in the 5.15-5.25 GHz band, the maximum power spectral density shall not exceed 11 dBm in any 1 megahertz band. If transmitting antennas of directional gain greater than 6 dBi are used, both the maximum conducted output power and the maximum power spectral density shall be reduced by the amount in dB that the directional gain of the antenna exceeds 6 dBi.

(2) For the 5.25-5.35 GHz and 5.47-5.725 GHz bands, the maximum conducted output power over the frequency bands of operation shall not exceed the lesser of 250 mW or $11 \text{ dBm} + 10 \log B$, where B is the 26 dB emission bandwidth in megahertz. In addition, the maximum power spectral density shall not exceed 11 dBm in any 1 megahertz band. If transmitting antennas of directional gain greater than 6 dBi are used, both the maximum conducted output power and the maximum power spectral density shall be reduced by the amount in dB that the directional gain of the antenna exceeds 6 dBi.

(3) For the band 5.725-5.85 GHz, the maximum conducted output power over the frequency band of operation shall not exceed 1 W. In addition, the maximum power spectral density shall not exceed 30 dBm in any 500-kHz band. If transmitting antennas of directional gain greater than 6 dBi are used, both the maximum conducted output power and the maximum power spectral density shall be reduced by the amount in dB that the directional gain of the antenna exceeds 6 dBi. However, fixed point-to-point U-NII devices operating in this band may employ transmitting antennas with directional gain greater than 6 dBi without any corresponding reduction in transmitter conducted power. Fixed, point-to-point operations exclude the use of point-to-multipoint systems, omnidirectional applications, and multiple collocated transmitters transmitting the same information. The operator of the U-NII device, or if the equipment is professionally installed, the installer, is responsible for ensuring that systems employing high gain directional antennas are used exclusively for fixed, point-to-point operations.

5.2 TEST PROCEDURE

For devices operating in the bands 5.15-5.25 GHz, 5.25-5.35 GHz, and 5.47-5.725 GHz, the above procedures make use of 1 MHz RBW to satisfy directly the 1 MHz reference bandwidth specified in § 15.407(a)(5). For devices operating in the band 5.725-5.85 GHz, the rules specify a measurement bandwidth of 500 kHz. Many spectrum analyzers do not have 500 kHz RBW, thus a narrower RBW may need to be used. The rules permit the use of a RBWs less than 1 MHz, or 500 kHz, “provided that the measured power is integrated over the full reference bandwidth” to show the total power over the specified measurement bandwidth (i.e., 1 MHz, or 500 kHz). If measurements are performed using a reduced resolution bandwidth (< 1 MHz, or <500 kHz) and integrated over 1 MHz, or 500 KHz bandwidth, the following adjustments to the procedures apply:

- a) Set $RBW \geq 1/T$, where T is defined in section II.B.I.a).
- b) Set $VBW \geq 3 RBW$.
- c) If measurement bandwidth of Maximum PSD is specified in 500 kHz, add $10\log(500\text{kHz}/RBW)$ to the measured result, whereas $RBW (< 500 \text{ KHz})$ is the reduced resolution bandwidth of the spectrum analyzer set during measurement.
- d) If measurement bandwidth of Maximum PSD is specified in 1 MHz, add $10\log(1\text{MHz}/RBW)$ to the measured result, whereas $RBW (< 1 \text{ MHz})$ is the reduced resolution bandwidth of spectrum analyzer set during measurement.
- e) Care must be taken to ensure that the measurements are performed during a period of continuous transmission or are corrected upward for duty cycle.

Note: As a practical matter, it is recommended to use reduced RBW of 100 KHz for the sections 5.c) and 5.d) above, since $RBW=100 \text{ KHZ}$ is available on nearly all spectrum analyzers.

5.3 DEVIATION FROM STANDARD

No deviation.

5.4 TEST SETUP



5.5 EUT OPERATION CONDITIONS

The EUT tested system was configured as the statements of 2.1 Unless otherwise a special operating condition is specified in the follows during the testing.

5.6 TEST RESULTS

Temperature :	26 °C	Relative Humidity :	54%
Pressure :	1015 hPa	Test Voltage :	AC 120V/60Hz
Test Mode :	TX		

Mode	Frequency	Ant A	Ant B	POWER SPECTRAL DENSITY TEST TOTAL	Limit (dBm/MHz)
		POWER SPECTRAL DENSITY TEST	POWER SPECTRAL DENSITY TEST		
802.11 a	5180 MHz	4.736	4.773	/	11
	5200 MHz	4.534	4.439	/	11
	5240 MHz	4.572	4.626	/	11
802.11 ac20	5180 MHz	2.296	2.247	5.28	9.99
	5200 MHz	2.277	2.219	5.26	9.99
	5240 MHz	2.728	2.630	5.69	9.99
802.11 ac40	5190 MHz	-1.335	-1.336	1.67	9.99
	5230 MHz	-1.080	-0.948	2.00	9.99
802.11 ac80	5210 MHz	0.644	0.534	3.60	9.99
802.11 n40	5190 MHz	0.504	0.520	3.52	9.99
	5230 MHz	-2.828	-3.015	0.09	9.99
802.11 n20	5180 MHz	3.315	3.487	6.41	9.99
	5200 MHz	3.047	3.071	6.07	9.99
	5240 MHz	3.779	3.554	6.68	9.99

Ant A

(802.11a) PSD plot on channel 36

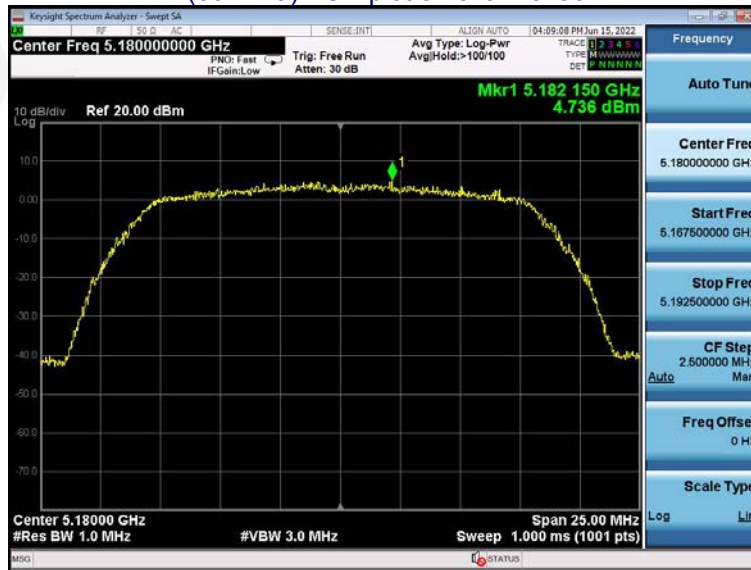

(802.11a) PSD plot on channel 40

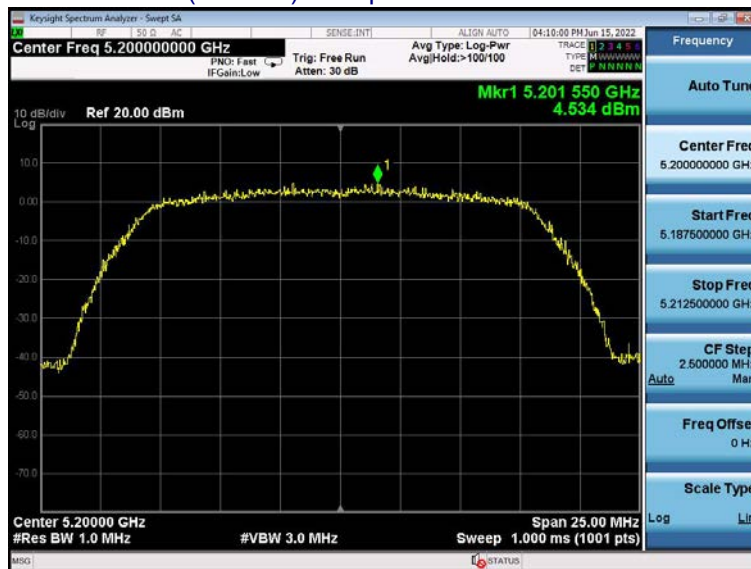

(802.11a) PSD plot on channel 48



(802.11ac20) PSD plot on channel 36

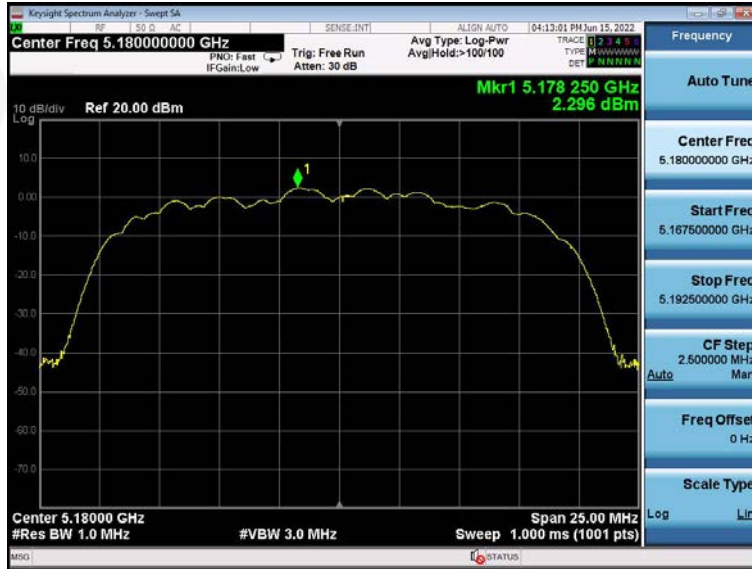

(802.11ac20) PSD plot on channel 40



(802.11ac20) PSD plot on channel 48



(802.11ac40) PSD plot on channel 38



(802.11ac40) PSD plot on channel 46



(802.11n40) PSD plot on channel 38



(802.11n40) PSD plot on channel 46



(802.11ac80) PSD plot on channel 42

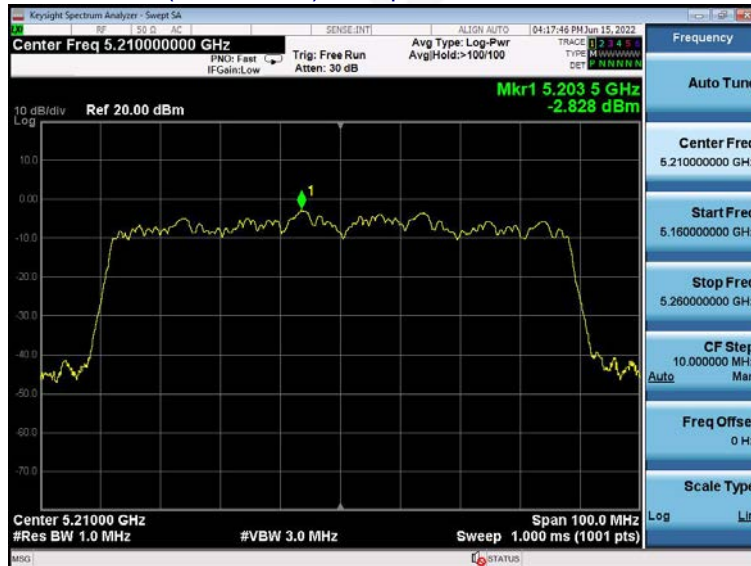

(802.11n20) PSD plot on channel 36

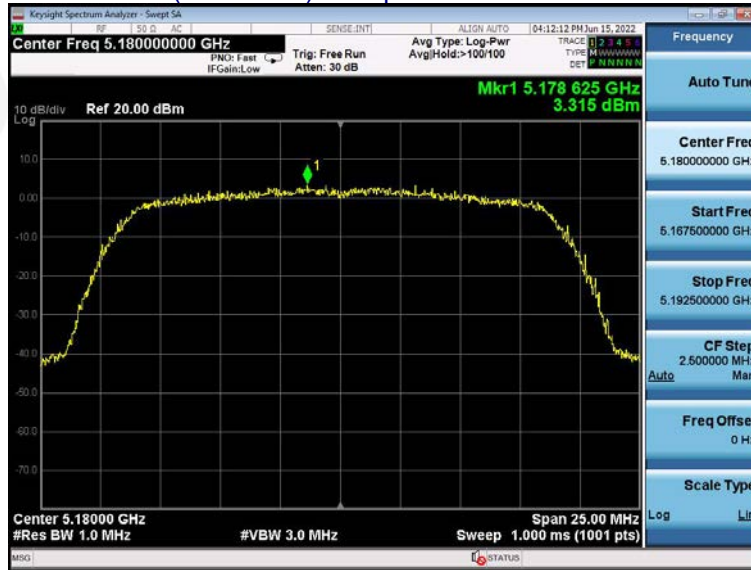

(802.11n20) PSD plot on channel 40

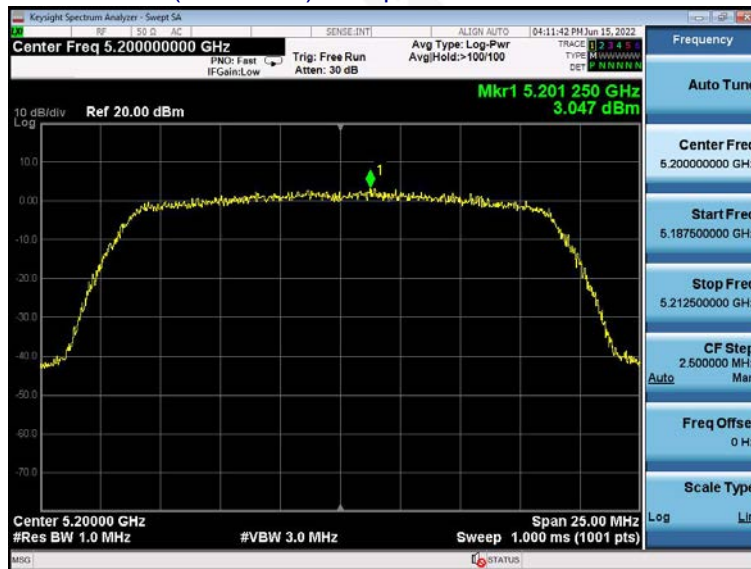

(802.11n20) PSD plot on channel 48



Ant B

(802.11a) PSD plot on channel 36

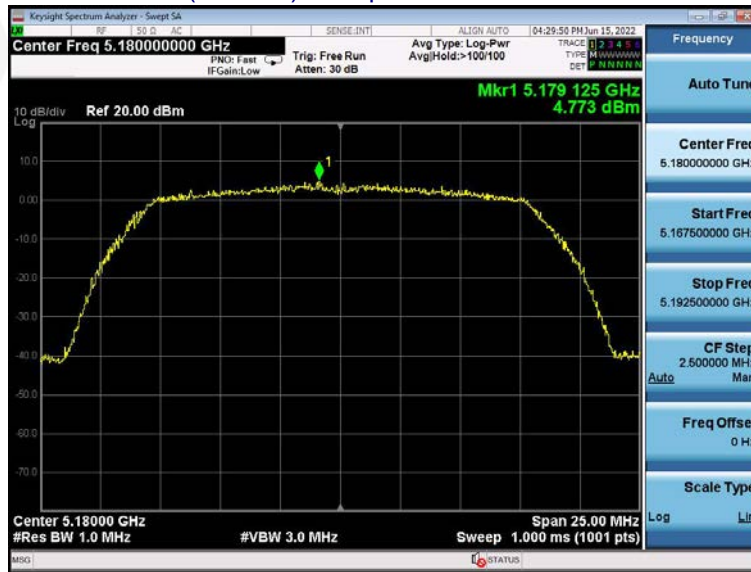

(802.11a) PSD plot on channel 40

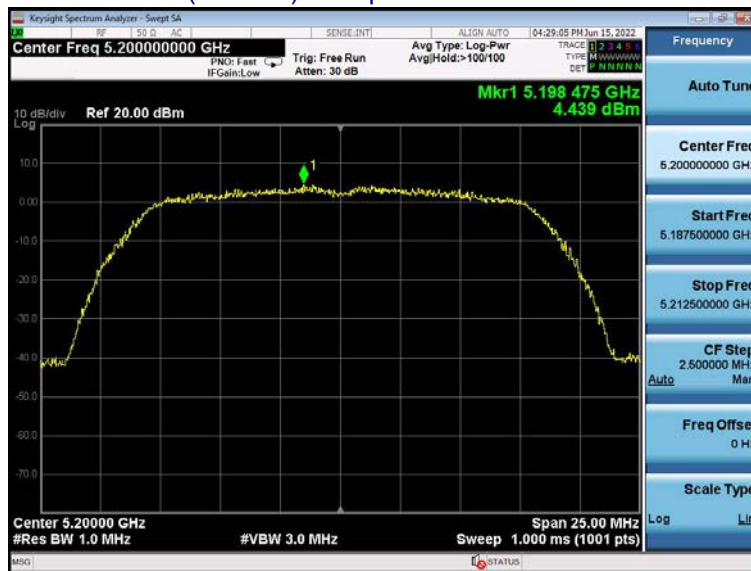

(802.11a) PSD plot on channel 48



(802.11ac20) PSD plot on channel 36



(802.11ac20) PSD plot on channel 40



(802.11ac20) PSD plot on channel 48



(802.11ac40) PSD plot on channel 38



(802.11ac40) PSD plot on channel 46



(802.11n40) PSD plot on channel 38



(802.11n40) PSD plot on channel 46



(802.11ac80) PSD plot on channel 42



(802.11n20) PSD plot on channel 36

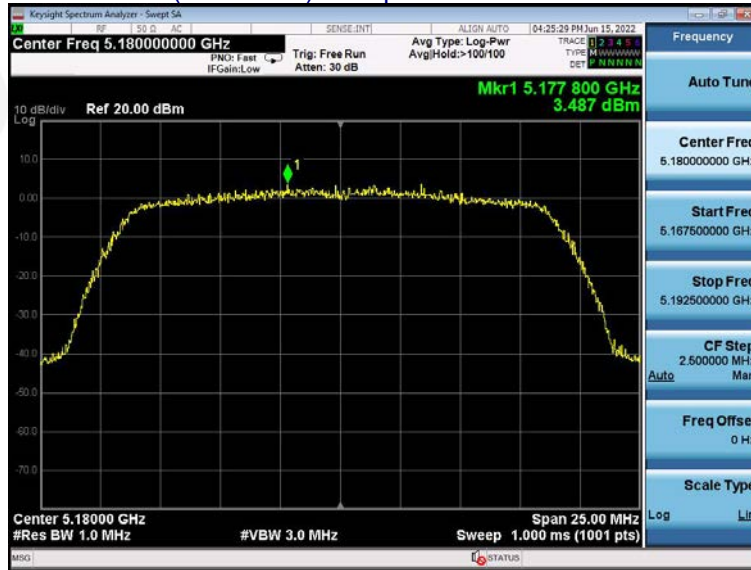

(802.11n20) PSD plot on channel 40



(802.11n20) PSD plot on channel 48



Temperature :	26 °C	Relative Humidity :	54%
Pressure :	1015 hPa	Test Voltage :	AC 120V/60Hz
Test Mode :	TX		

Mode	Frequency	Ant A	Ant B	POWER SPECTRAL DENSITY TEST TOTAL	Limit (dBm/500kHz)
		Measured Power Density (dBm/500kHz)	Measured Power Density (dBm/500kHz)		
802.11 a	5745 MHz	4.313	4.578	/	30
	5785 MHz	3.214	4.208	/	30
	5825 MHz	3.208	4.185	/	30
802.11 ac20	5745 MHz	2.002	3.614	5.89	28.99
	5785 MHz	1.546	2.218	4.91	28.99
	5825 MHz	2.132	2.314	5.23	28.99
802.11 ac40	5755 MHz	0.116	1.942	4.13	28.99
	5795 MHz	0.121	1.897	4.11	28.99
802.11 ac80	5775 MHz	1.684	1.845	4.78	28.99
802.11 n40	5755 MHz	1.566	1.835	4.71	28.99
	5795 MHz	-2.329	-2.400	0.65	28.99
802.11 n20	5745 MHz	2.049	2.152	5.11	28.99
	5785 MHz	3.455	2.719	6.11	28.99
	5825 MHz	2.015	2.483	5.27	28.99

Ant A

(802.11a) PSD plot on channel 149



(802.11a) PSD plot on channel 157



(802.11a) PSD plot on channel 165



(802.11ac20) PSD plot on channel 149



(802.11ac20) PSD plot on channel 157

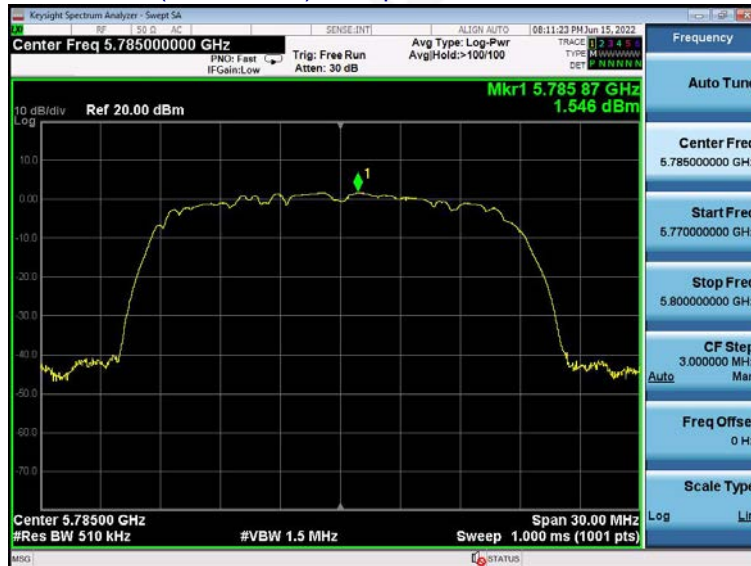

(802.11ac20) PSD plot on channel 165



(802.11ac40) PSD plot on channel 151



(802.11ac40) PSD plot on channel 159



(802.11n40) PSD plot on channel 151



(802.11n40) PSD plot on channel 159



(802.11ac80) PSD plot on channel 155

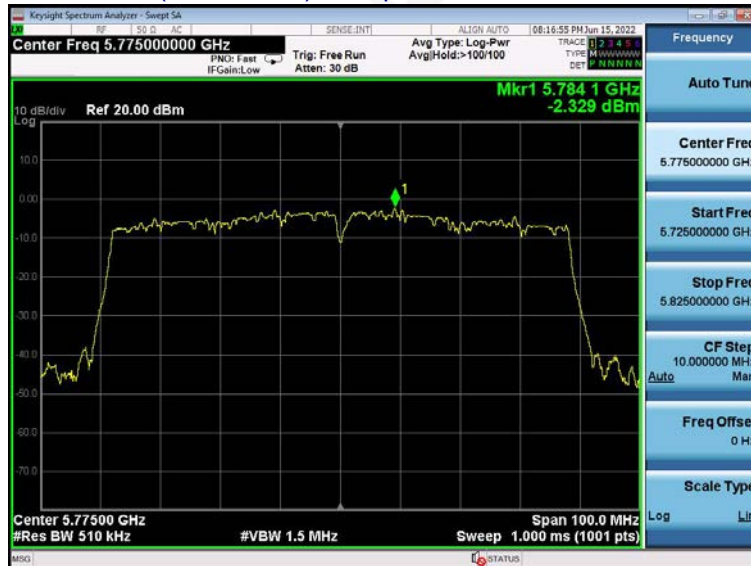

(802.11n20) PSD plot on channel 149



(802.11n20) PSD plot on channel 157



(802.11n20) PSD plot on channel 165



Ant B

(802.11a) PSD plot on channel 149



(802.11a) PSD plot on channel 157



(802.11a) PSD plot on channel 165



(802.11ac20) PSD plot on channel 149



(802.11ac20) PSD plot on channel 157



(802.11ac20) PSD plot on channel 165



(802.11ac40) PSD plot on channel 151



(802.11ac40) PSD plot on channel 159



(802.11n40) PSD plot on channel 151



(802.11n40) PSD plot on channel 159



(802.11ac80) PSD plot on channel 155



(802.11n20) PSD plot on channel 149

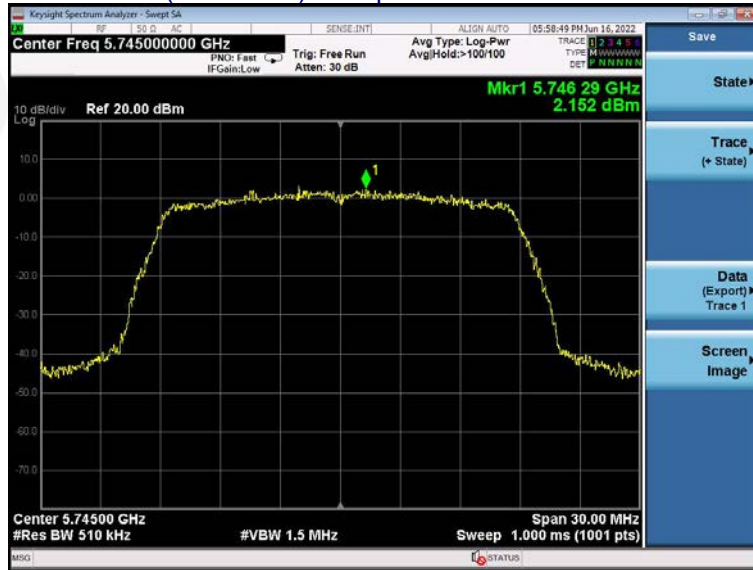

(802.11n20) PSD plot on channel 157



(802.11n20) PSD plot on channel 165



6. 26DB & 6DB EMISSION BANDWIDTH

6.1 APPLIED PROCEDURES / LIMIT

The maximum power spectral density is measured as a conducted emission by direct connection of a calibrated test instrument to the equipment under test. If the device cannot be connected directly, alternative techniques acceptable to the Commission may be used. Measurements in the 5.725-5.85 GHz band, the minimum bandwidth 6 dB bandwidth of U-NII devices shall be at least 500KHz. Measurements in the 5.15-5.25 GHz, 5.25-5.35 GHz, and the 5.47-5.725 GHz bands are made over a bandwidth of 1 MHz or the 26 dB emission bandwidth of the device, whichever is less. A narrower resolution bandwidth can be used, provided that the measured power is integrated over the full reference bandwidth.

6.2 TEST PROCEDURE

- a) Set RBW = 100KHz.
- b) Set the VBW > RBW.
- c) Detector = Peak.
- d) Trace mode = max hold.
- e) Measure the maximum width of the emission that is constrained by the frequencies associated with the two outermost amplitude points (upper and lower frequencies) that are attenuated by 6 dB relative to the maximum level measured in the fundamental emission.

The following procedure shall be used for measuring (99 %) power bandwidth:

1. Set center frequency to the nominal EUT channel center frequency.
2. Set span = 1.5 times to 5.0 times the OBW.
3. Set RBW = 1 % to 5 % of the OBW
4. Set VBW $\geq 3 \cdot$ RBW
5. Video averaging is not permitted. Where practical, a sample detection and single sweep mode shall be used. Otherwise, peak detection and max hold mode (until the trace stabilizes) shall be used.
6. Use the 99 % power bandwidth function of the instrument (if available).
7. If the instrument does not have a 99 % power bandwidth function, the trace data points are recovered and directly summed in power units. The recovered amplitude data points, beginning at the lowest frequency, are placed in a running sum until 0.5 % of the total is reached; that frequency is recorded as the lower frequency. The process is repeated until 99.5 % of the total is reached; that frequency is recorded as the upper frequency. The 99% occupied bandwidth is the difference between these two frequencies.



6.3 EUT OPERATION CONDITIONS

The EUT tested system was configured as the statements of 2.4 Unless otherwise a special operating condition is specified in the follows during the testing.

6.4 TEST RESULTS

Temperature :	26 °C	Relative Humidity :	54%
Pressure :	101kPa	Test Voltage :	AC 120V/60Hz
Test Mode :	TX		

Test CH	Ant A						Limit (KHz)	Result
	-26dB Channel Bandwidth (MHz)							
	802.11a	802.11ac(20)	802.11ac(40)	802.11ac(80)	802.11n(40)	802.11n(20)		
Lowest	18.81	19.05	37.53		38.33	19.36	>500	Pass
Middle	18.84	19.07		77.59		19.62		
Highest	18.93	19.07	37.50		38.24	19.42		

Test CH	Ant B						Limit (KHz)	Result
	-26dB Channel Bandwidth (MHz)							
	802.11a	802.11ac(20)	802.11ac(40)	802.11ac(80)	802.11n(40)	802.11n(20)		
Lowest	19.08	19.03	37.51		37.96	19.32	>500	Pass
Middle	19.02	19.06		77.59		19.45		
Highest	18.98	19.06	37.51		38.55	19.32		

Ant A
Test plot
(802.11a) Bandwidth plot on channel 36



(802.11a) Bandwidth plot on channel 40



(802.11a) Bandwidth plot on channel 48

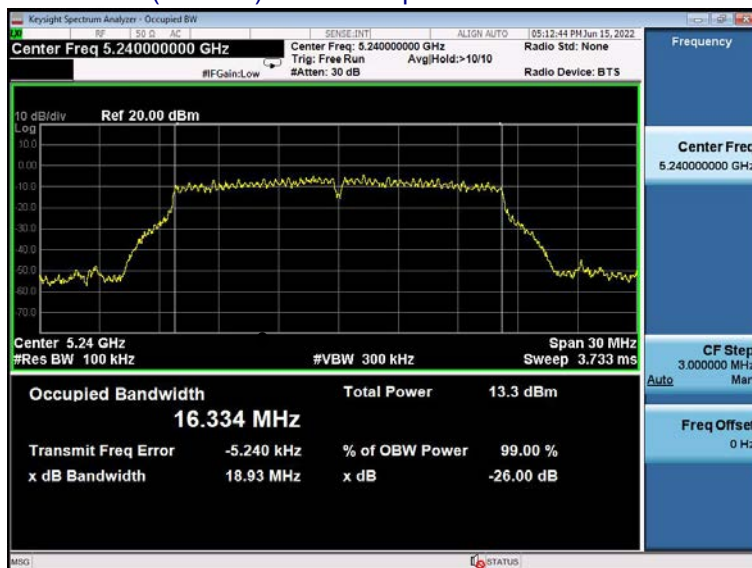

Test plot
(802.11 ac20) Bandwidth plot on channel 36



(802.11 ac20) Bandwidth plot on channel 40

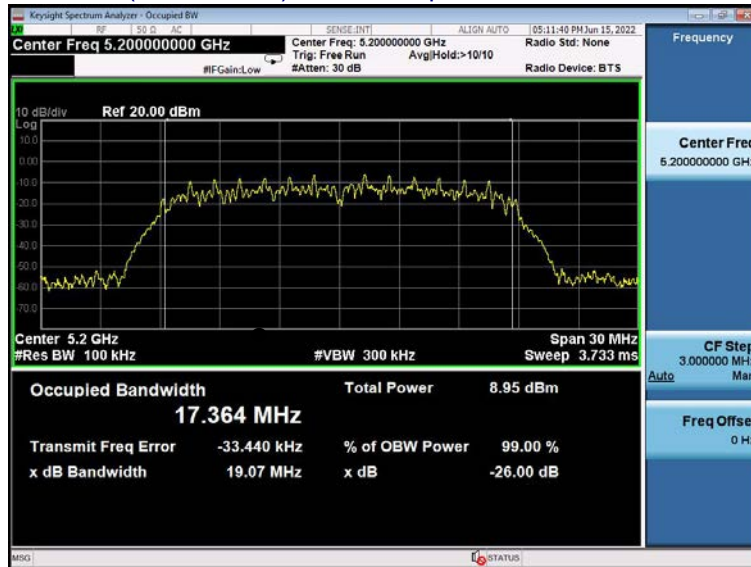

(802.11 ac20) Bandwidth plot on channel 48

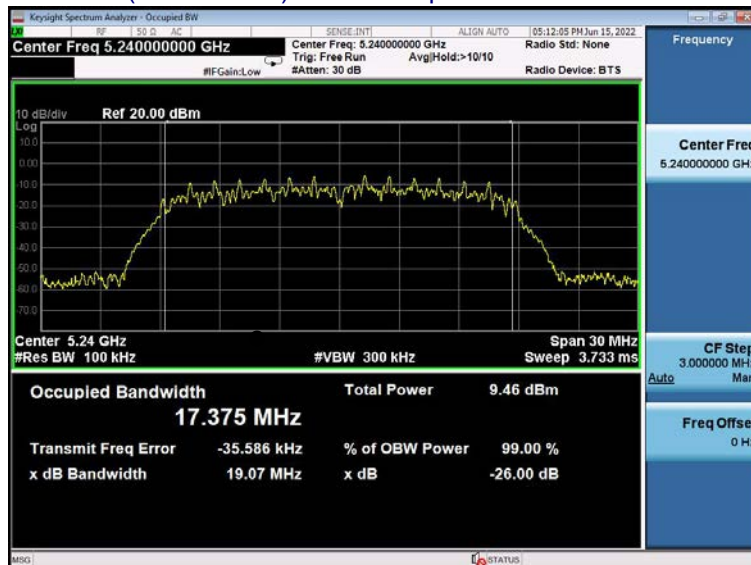

Test plot

(802.11ac40) Bandwidth plot on channel 38

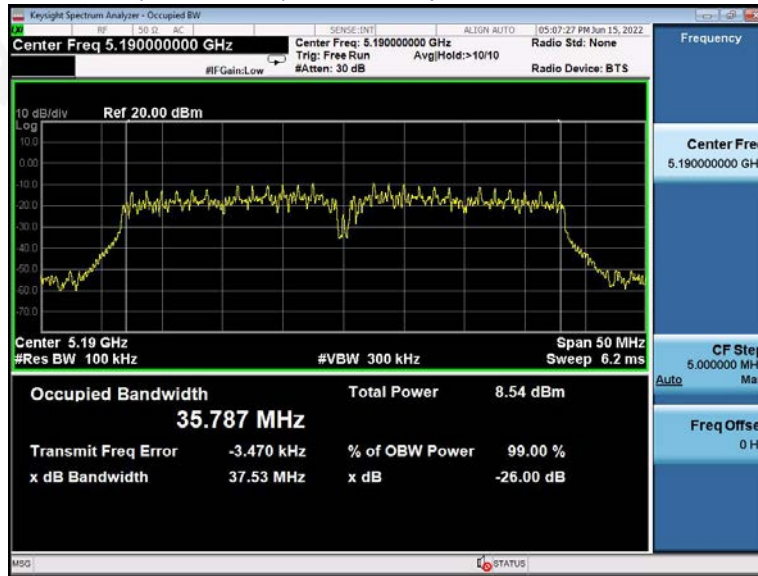

(802.11ac40) Bandwidth plot on channel 46

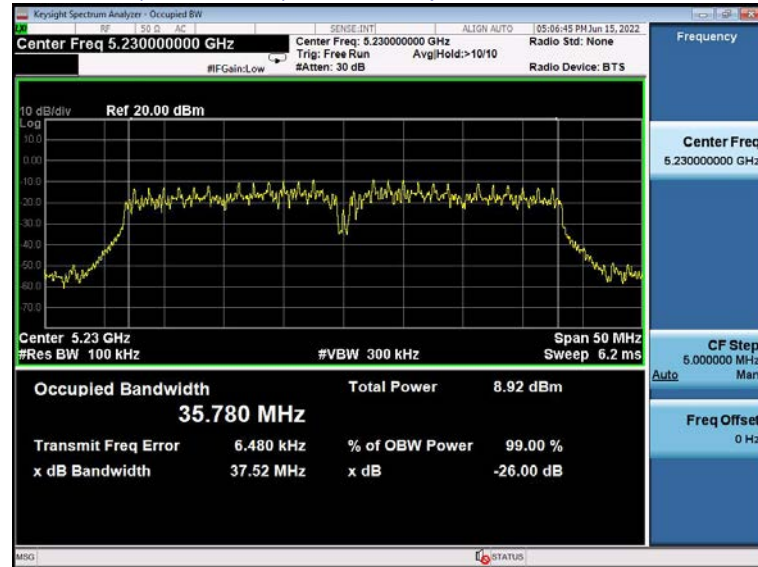

(802.11n40) Bandwidth plot on channel 38

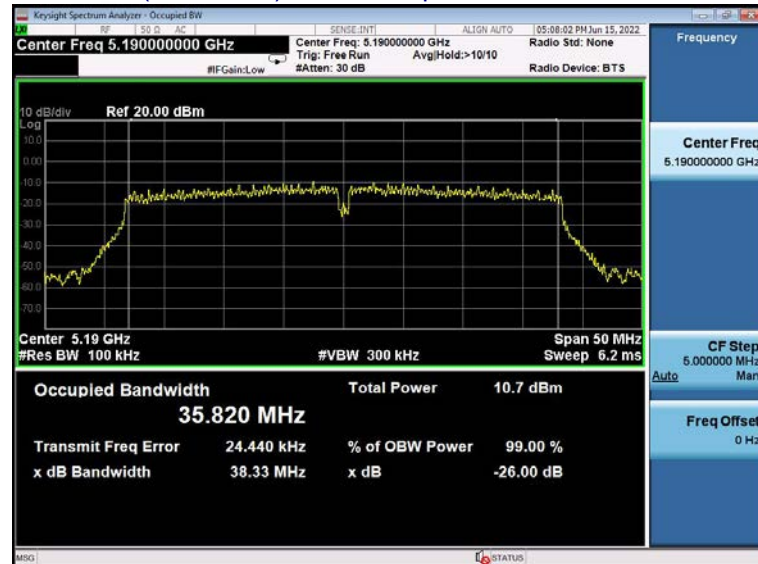

Test plot

(802.11n40) Bandwidth plot on channel 46

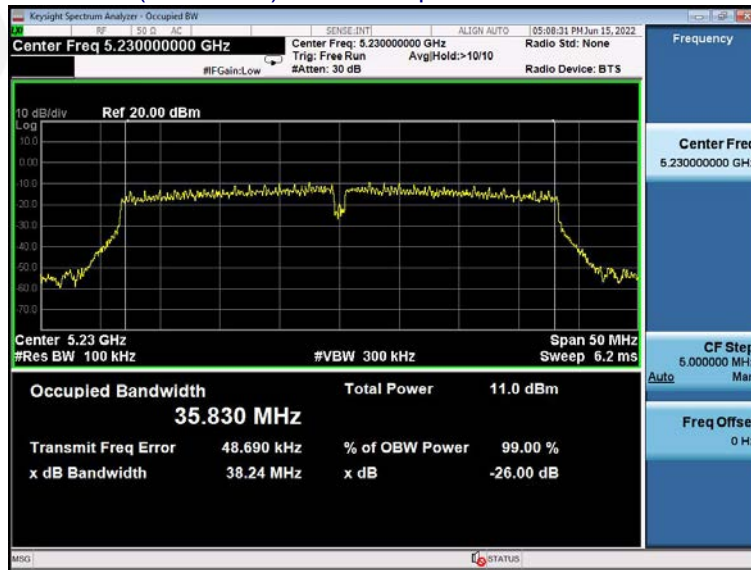

(802.11ac80) Bandwidth plot on channel 42

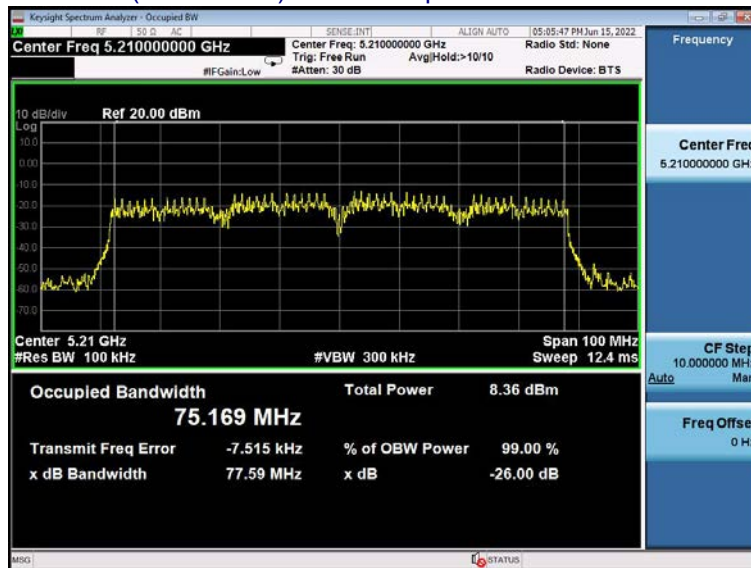

Test plot

(802.11 n20) Bandwidth plot on channel 36



(802.11 n20) Bandwidth plot on channel 40



(802.11 n20) Bandwidth plot on channel 48



Ant B
Test plot

(802.11a) Bandwidth plot on channel 36



(802.11a) Bandwidth plot on channel 40



(802.11a) Bandwidth plot on channel 48



Test plot

(802.11 ac20) Bandwidth plot on channel 36

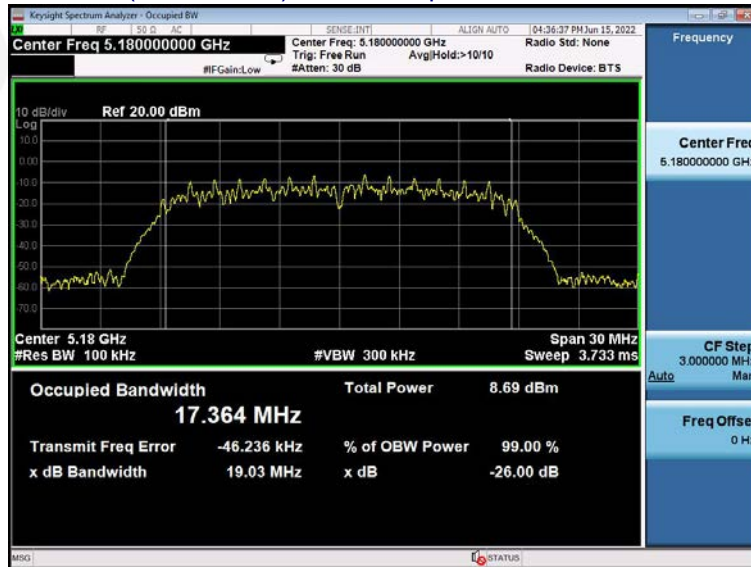

(802.11 ac20) Bandwidth plot on channel 40

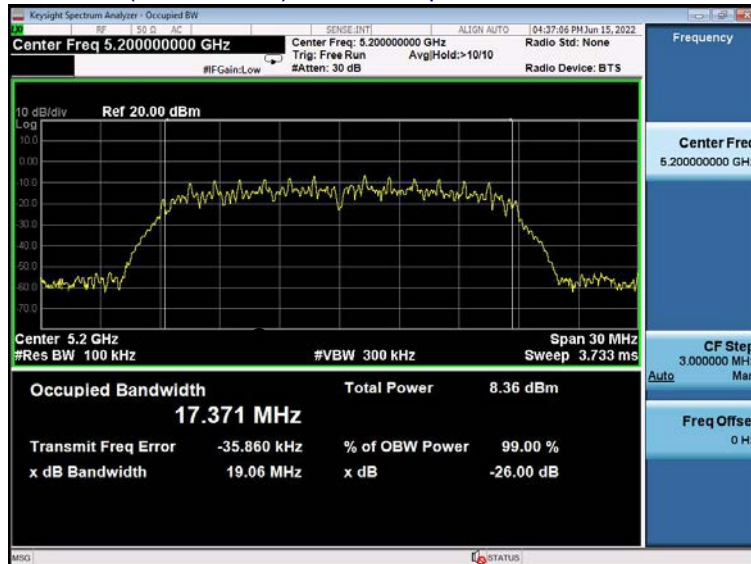

(802.11 ac20) Bandwidth plot on channel 48

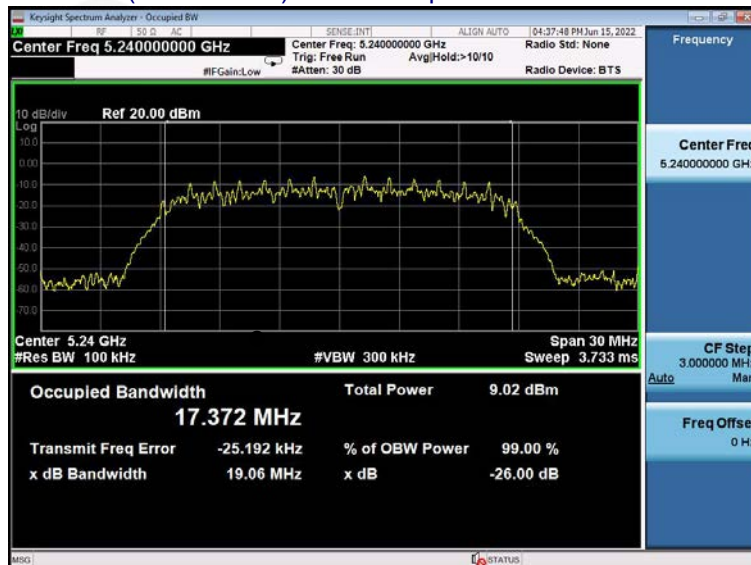

Test plot

(802.11ac40) Bandwidth plot on channel 38

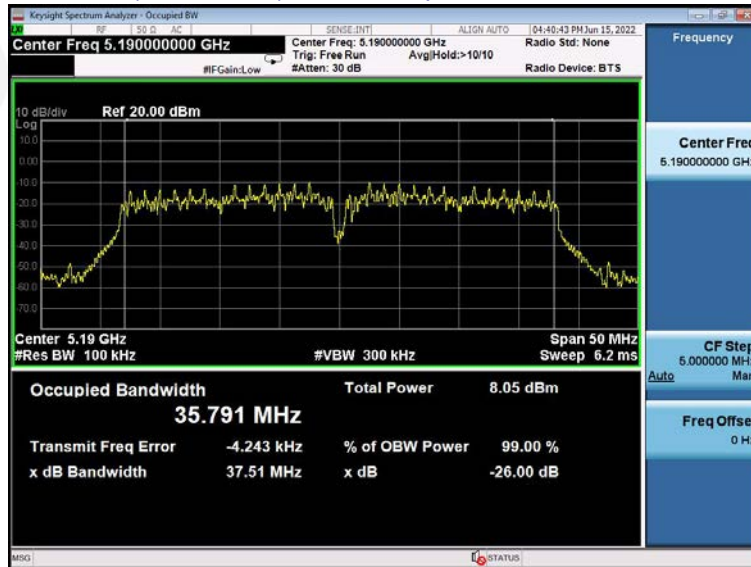

(802.11ac40) Bandwidth plot on channel 46

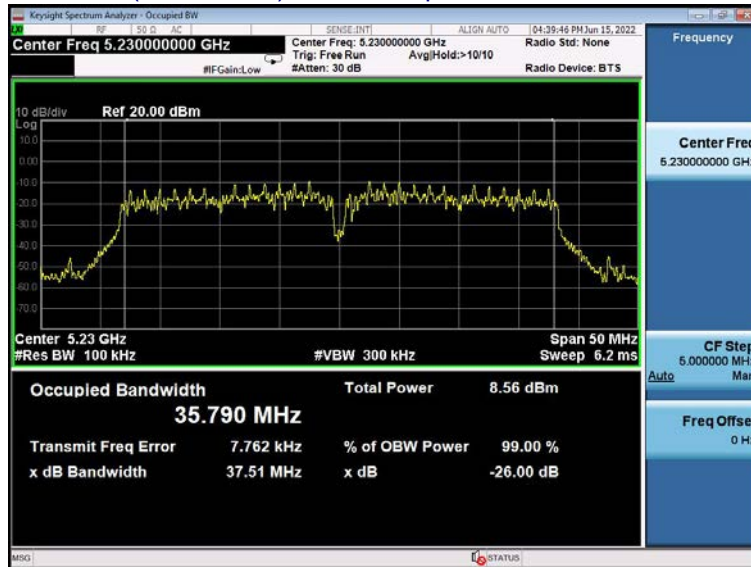

(802.11n40) Bandwidth plot on channel 38

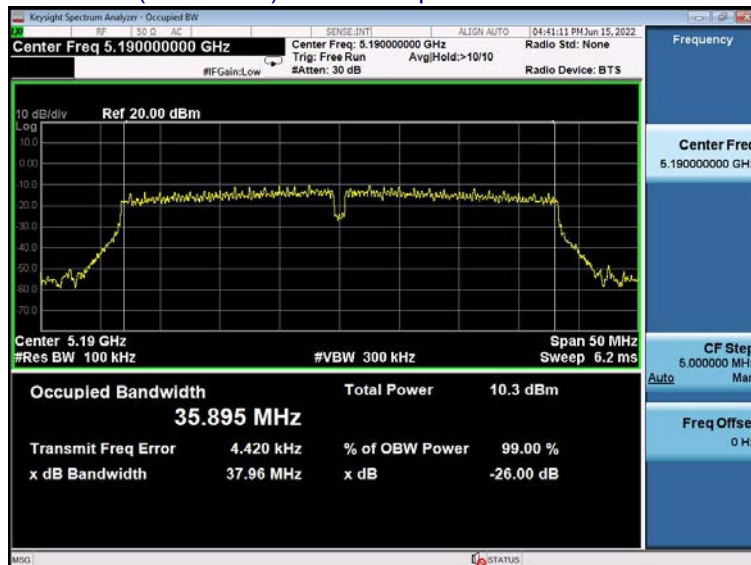

Test plot

(802.11n40) Bandwidth plot on channel 46

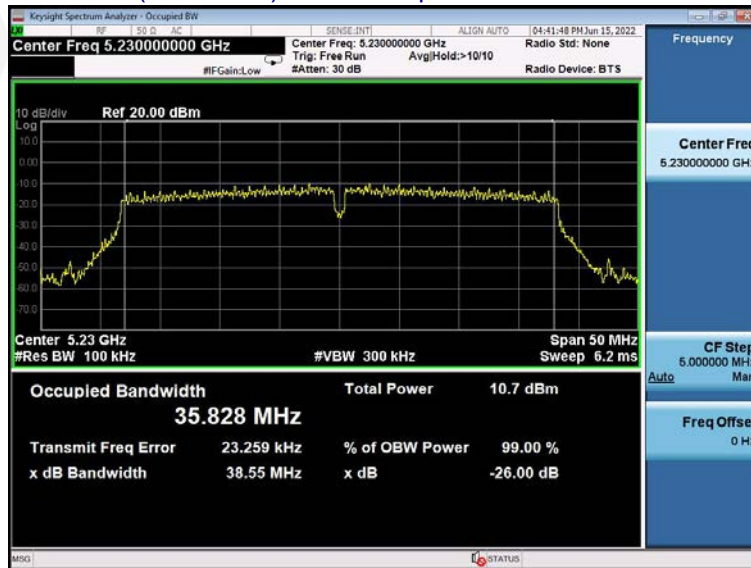

(802.11ac80) Bandwidth plot on channel 42

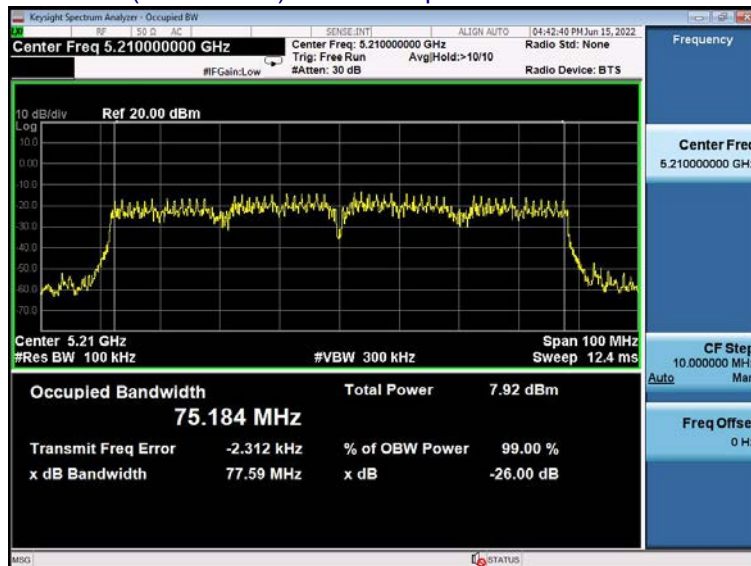

Test plot

(802.11 n20) Bandwidth plot on channel 36



(802.11 n20) Bandwidth plot on channel 40



(802.11 n20) Bandwidth plot on channel 48

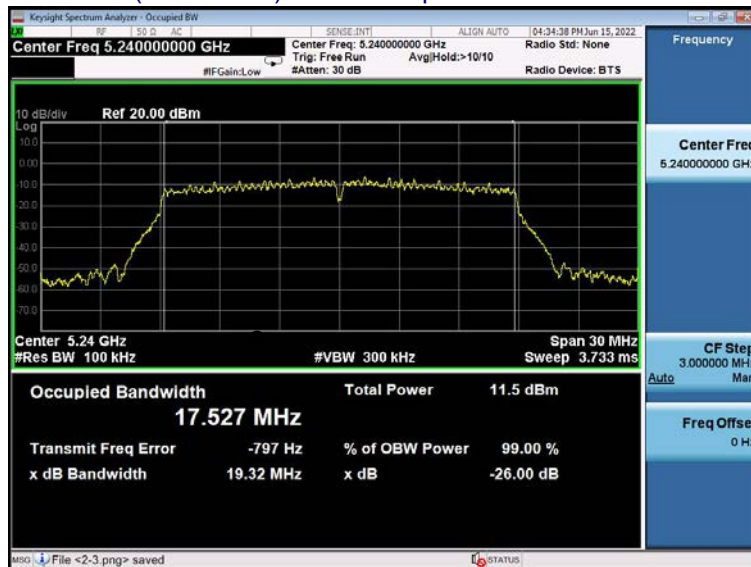

Test CH	Ant A						Limit (KHz)	Result
	-6dB Channel Bandwidth (MHz)							
	802.11a	802.11ac (20)	802.11ac (40)	802.11ac (80)	802.11n (40)	802.11n (20)		
Lowest	15.72	15.11	35.10		35.39	16.63	>500	Pass
Middle	15.97	15.12		75.13		16.00		
Highest	16.07	15.11	35.10		35.70	16.34		

Test CH	Ant B						Limit (KHz)	Result
	-6dB Channel Bandwidth (MHz)							
	802.11a	802.11ac (20)	802.11ac (40)	802.11ac (80)	802.11n (40)	802.11n (20)		
Lowest	16.29	15.11	35.10		35.12	16.31	>500	Pass
Middle	15.70	15.11		75.12		16.27		
Highest	16.02	15.12	35.10		35.07	17.18		

Ant A
Test plot

(802.11a) Bandwidth plot on channel 149



(802.11a) Bandwidth plot on channel 157



(802.11a) Bandwidth plot on channel 165



Test plot

(802.11 ac20) Bandwidth plot on channel 149

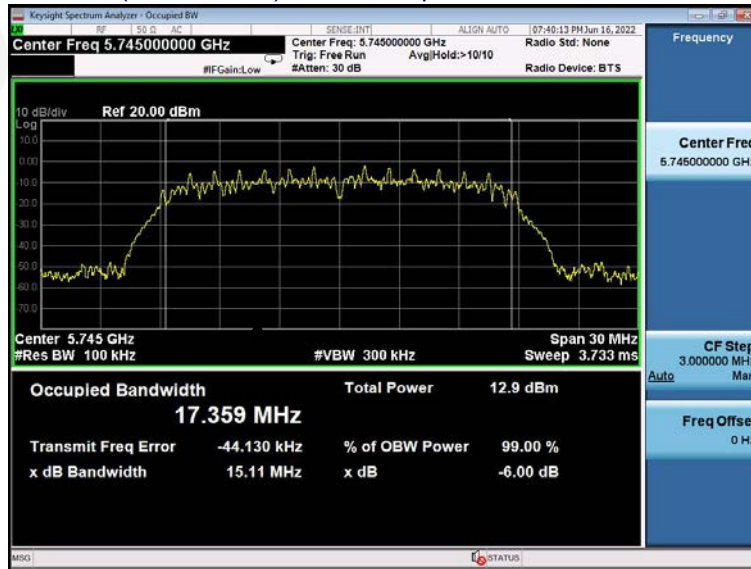

(802.11 ac20) Bandwidth plot on channel 157

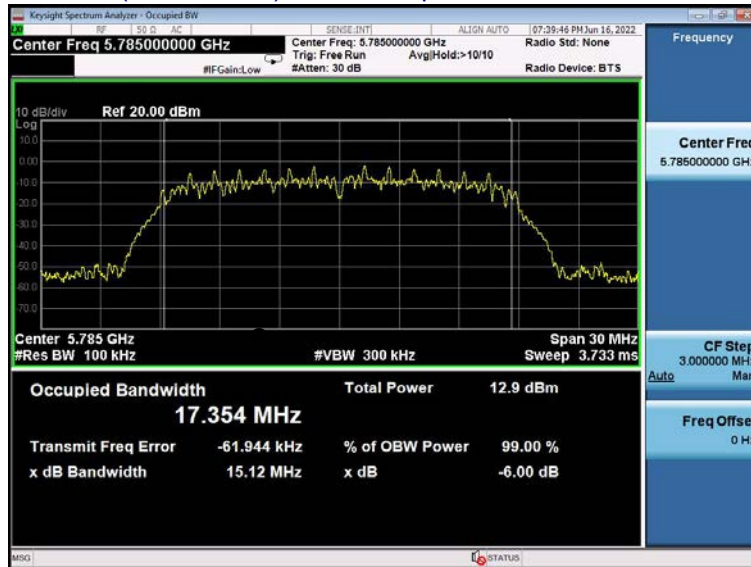

(802.11 ac20) Bandwidth plot on channel 165

