

*CLEANAIRE*

# 4 in 1 HEPA-Plasma Air Purifier

## INSTRUCTION MANUAL

*CLEANAIRE*



## Table of Contents

<b>Introduction</b> .....	<b>1</b>
<b>Safety Instructions</b> .....	<b>2</b>
<b>The Product Overview</b> .....	<b>5</b>
<b>How It Works</b> .....	<b>7</b>
<b>Product Specifications</b> .....	<b>8</b>
<b>Unpacking and Setup</b> .....	<b>8</b>
<b>Operation Instructions</b> .....	<b>9</b>
<b>Using the AiLivin App</b> .....	<b>13</b>
<b>Filter Replacement</b> .....	<b>15</b>
<b>Remote Battery Replacement</b> .....	<b>17</b>
<b>Troubleshooting</b> .....	<b>18</b>
<b>Cleaning and Maintenance</b> .....	<b>19</b>

## Performance Verification

When you are shopping for an air purifier, it is recommended to:

- A.** Look at suggested room size
- B.** Refer to the tobacco smoke, dust, and pollen Clean Air Delivery Rate (CADR) numbers. The higher the number, the faster the unit filters the air. We make certain that CleanAire purifiers are independently tested.

**SUGGESTED ROOM SIZE:**  
465 Square feet (43.2 m<sup>2</sup>)

**THIS UNIT'S CADR RATINGS:**  
Tobacco Smoke: 300  
Dust: 300  
Pollen: 300

## Introduction

Thank you for purchasing the CleanAire 4 in 1 HEPA-PLASMA Air Purifier. This device incorporates a 4-in-1 high efficiency particulate air (HEPA) filter with a plasma generator to efficiently filter indoor air, removing particulate matter with a diameter of less than 2.5 microns (PM2.5). It can also absorb harmful chemicals such as formaldehyde, smoke, volatile organic compounds (VOCs) and other harmful gases. The CleanAire 4 in 1 HEPA-PLASMA Air Purifier is a comprehensive solution to remove the contaminants from the air you breathe.

There are two models of the CleanAire 4 in 1 HEPA-PLASMA Air Purifier:

- CAHP-50XX02 (without WiFi)
- CAHP-50XX02C (with WiFi)

Note: XX is the color code. The unit is available in a variety of colors.

## Replacement Filters

Only use genuine CleanAire replacement filters with your CleanAire 4 in 1 HEPA-PLASMA Air Purifier. Use of any other filters may compromise the proper operation of your unit and potentially void your warranty.

- Part Number CA02FT-1  
Replace every 18 months, or more frequently if necessary

## Remote Control

The remote control can be purchased separately: Part Number DH02AC-1

## Remote Control Battery

- **Battery Type:**  
CR2032

To purchase replacement filters, remote controls, or batteries visit

[www.cleanaire.com](http://www.cleanaire.com)

## Safety Instructions

### READ THESE SAFETY INSTRUCTIONS BEFORE USE

When using electrical appliances, basic precautions should always be followed to reduce the risk of fire, electric shock, and injury to persons, including the following:

**WARNING: to reduce the risk of fire or electric shock, do not use this device with any solid-state speed control device.**

- ! Read all the instructions before operating the unit.
- ! This product complies with the maximum allowable concentration of ozone of 0.050 parts per million by volume (ppmv) in a 24 hour period.
- ! Place the unit in a location that is convenient and where it is unlikely to be bumped or overturned.
- ! DO NOT sit, stand, or place heavy objects on the unit.
- ! The unit must only be used in the upright position.
- ! Do not move the unit when operating.
- ! NEVER place containers of liquids or drinks on top of the unit. Spilling liquids into the unit can damage the machine and potentially cause a shock or fire hazard.
- ! Children should not use this equipment alone. Keep the unit away from small children and pets.
- ! Do not use the unit outdoors.
- ! NEVER use the unit unless it is fully assembled.
- ! This product can only be used with the supplied accessories.
- ! DO NOT allow foreign objects to enter ventilation or exhaust opening as this may cause electric shock or damage to the unit. DO NOT block air outlets or intakes.
- ! When using electrical appliances, always follow basic precautions to reduce the risk of fire, electric shock, and personal injury.
- ! Locate the unit near the outlet and avoid using an extension cord or power strip.

## Safety Information (Cont.)

- ! This appliance has a polarized plug (one blade is wider than the other). To reduce the risk of electric shock, this plug is intended to fit only one way in a polarized outlet. If the plug does not fit fully in the outlet, reverse the plug. If it still does not fit, contact a qualified electrician. DO NOT attempt to defeat this safety feature.
- ! Ensure the electrical outlet used with the Purifier is not loose or damaged. A poor electrical connection can result in overheating and damage to the power cord. If the outlet needs to be serviced contact a licensed electrician for repairs.
- ! ALWAYS turn the unit OFF and unplug from the wall outlet when not in use.
- ! To disconnect the unit, make sure it is powered OFF then grip the plug and pull it from the wall outlet. NEVER pull the cord to unplug it.
- ! Do not use any electrical appliance that has a damaged power cord or plug.
- ! Do not use any electrical product that you believe may be faulty product, or that has been dropped or damaged in any way.
- ! Keep the power cord away from hot surfaces.
- ! Do not route the power cord under carpet or cover it with carpet. Route the power cord to minimize the possibility that someone could trip over it.
- ! Do not expose the unit to excessive moisture. Avoid operating it where it might come in contact with water, such as bathrooms, laundry rooms or other damp places.
- ! Ensure the electrical outlet used with the unit is not loose or damaged. A poor electrical connection can result in overheating and damage to the power cord. If the outlet needs to be serviced contact a licensed electrician for repairs.
- ! Disconnect the power before cleaning or servicing the unit.
- ! The unit is not user serviceable. Do not attempt to repair the product yourself. In the event of a failure, contact customer service for repair or replacement.

### Battery Precautions

- ! **WARNING: This product contains a lithium button/coin cell battery. If a new or used lithium button/coin cell battery is swallowed or enters the body, it can cause severe internal burns and can lead to death in as little as 2 hours. If you think batteries might have been swallowed, seek immediate medical attention.**
- ! Incorrect battery usage may cause battery fluid leakage and/or damage.
- ! When not using remote for extended periods of time, remove the battery.

- ! Avoid dropping or damaging the remote.
- ! Always completely secure the battery compartment. If the battery compartment does not close securely, stop using the product, remove the batteries, and keep it away from children.
- ! The batteries should be disposed of properly, including keeping them away from children. Even used batteries may cause injury.

## The Product Overview

Pls refer to Figure 1 for the product overview.

- **Chassis:** The chassis of the unit has two chambers. The 4-in-1 HEPA filter is in the bottom chamber. The plasma generator mechanism is in the upper chamber. The bottom chamber is concealed by a magnetically attached screen and houses the 4-in-1 HEPA filter. A control panel is located on top of the chassis.
- **4-in-1 HEPA Filter:** The cylindrical 4-IN-1 HEPA filter has a Pre-filter, anti-bacterial coating, the true HEPA filter, and an activated carbon filter to provide comprehensive filtration and disinfection capabilities.
- **Control Panel:** At the top of the unit is a control panel with a number of touch-sensitive buttons. These buttons are used to control operation of the unit. The inner light ring around the control panel will change colors to display indoor air quality status.
- **Remote Control:** A battery powered infrared remote allows convenient remote control of the unit. The remote control has a magnetic back and can be stored on the side bracket of the control panel.
- **Power Cord:** (Not shown) Used to connect the CleanAire 4 in 1 HEPA-PLASMA Air Purifier to AC power.

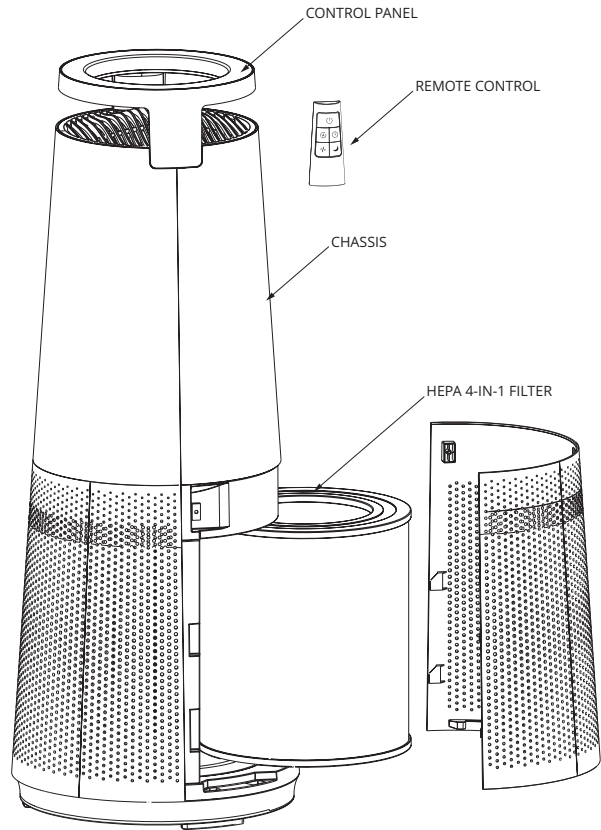

Figure 1. Major Components

## How It Works

The CleanAire 4 in 1 HEPA-PLASMA Air Purifier incorporates a 6-stage cleaning system to help clean the air. A fan forces air through the unit from bottom to top. There are six stages to the unit:

- **Stage 1: Plasma Wall Set.** The plasma wall set enlarges the diameter of particles and generates an electrostatic magnetic field, thus improving the downstream filter's absorption rates.
- **Stage 2: Pre-Filter.** Captures large particulate matter including dust, pollen, hair and pet dander.
- **Stage 3: Anti-Bacterial Coating.** The anti-bacterial coating kills more microbes including bacteria and viruses captured in the filter.
- **Stage 4: True HEPA Filter.** The true High Efficiency Particulate Air (HEPA) filter captures up to 99.97% of particles down to 0.3 microns in diameter.
- **Stage 5: Activated Carbon Filter.** The activated carbon filter traps odors, gases, and volatile organic compounds (VOCs).
- **Stage 6: Active Plasma Set.** The active plasma set generates positive ions and negative ions that are diffused into the air. These ions keep killing bacteria and viruses in the room. As the room is filled with negative oxygen ions, you will enjoy a fresh smell - like the forest after a rain shower. The ozone generated is well within US EPA safety limits and the optimum concentration (less than 0.05ppm).

## Product Specifications

Power Consumption	62 Watts
Input Voltage	100-240 VAC 50/60 Hz
Operating Temperature Range	32° F to 95° F (0°C to 35° C)
Storage Temperature Range	-40° F to 158°F (-40° C to 70° C)
Dimensions (LxWxH)	13.6 X 9.13 X 35.18 inches (347 X 232 X 893mm)
Applicable Room Size	538.2 ft <sup>2</sup> (50m <sup>2</sup> )
Net Weight	21.6 lbs (9.8 kg)
CADR	300 CFM (510m <sup>3</sup> /h)
Remote Control Dimensions	1.77 X 0.79 X 4.13 inches (45 X 20 X105 mm)

## Unpacking and Setup

1. Remove the unit from the box and check that all the items shown in Figure 1 are included. It is a good idea to retain the packaging for storing the unit or in the event it must be shipped back for service.
2. The unit is shipped with the 4-in-1 HEPA filter sealed inside a protective plastic bag. Detach the bottom cover and remove the 4-in-1 HEPA filter from the plastic bag, then replace it inside the unit and replace the bottom cover.
3. Locate the unit on a flat, solid surface in proximity to an AC electrical outlet.
4. Connect the AC adapter to the unit, and route the power cord to the outlet, but do not plug it in yet. Make sure that the power cord is out of the way and does not pose a tripping hazard, and is out of reach of children and pets.

***Congratulations! You are now ready to enjoy clean safe air using the CleanAire 4 in 1 HEPA-PLASMA Air Purifier.***

## Operation Instructions







### The Control Panel

Operation of the unit is controlled by buttons on the Control Panel as showed in Figure 2.



**Figure 2. Control Panel**

Icon	Description
	Power ON/OFF Button. Controls operation of the unit. Pressing the button turns the unit ON or OFF. Any time the unit is turned on in the future it will start up the same operating mode it was in when last operated.
	Auto Mode Button. The inner light ring around the control panel will work and indicate the indoor air quality as monitored by the PM2.5 sensor: Blue: Air Quality Good (0 to 100 µg/m <sup>3</sup> ) Yellow: Air Quality Moderate (100 to 200 µg/m <sup>3</sup> ) Red: Air Quality Poor (above 200 µg/m <sup>3</sup> ) The machine will automatically adjust the fan speed according to the air quality. When the air quality detected is poor, the fan speed is adjusted higher; when the air quality is good, the fan speed is adjusted lower. The light will be off in standby mode.

Icon	Description
	Sleep Mode Button. Press this button to place the unit in sleep mode. In sleep mode the fan runs at ultra-low speed for silence, and the light ring turns off.
	Fan Speed Button. Use this button to adjust the fan speed, toggling through the 1-2-3 fan speeds. An indicator corresponding to the selected fan speed will illuminate. When the unit is in Auto mode or Sleep mode, pressing the Fan Speed button will cancel either mode.
	Plasma On/Off Button. Press the icon to toggle the plasma sterilization function on or off. This setting will improve the sterilization ability, and particularly recommended in cold and flu seasons. NOTE: This button is not on the Remote Control.
	Filter Replacement Indicator/Button. Indicator will illuminate red when the HEPA filter needs to be replaced. After replacing the filter, press and hold this button for 3 seconds to reset the filter life countdown.
	Timer Button. The Timer Button allows you to select how long the machine will run before it automatically shuts off. There are three pre-set times: 2, 4 and 8 hours. Press the icon toggle through the options (2H-4H-8H-None). Once selected, an internal timer controls operation of the unit for the selected duration. Once the timer expires, the unit shuts down and enters the standby mode. NOTE: Do not use this option if you want the unit to run continuously.
	WiFi Status Indicator/Button (WiFi equipped models only). Illuminates to indicate WiFi connection function or status: <ul style="list-style-type: none"> <li>• Flashing green: Attempting to connect</li> <li>• Steady green: Connection successful</li> <li>• Steady red: Not connected</li> </ul> <p>The button is also used to disconnect from WiFi when it is connected. Press the button a second time and it will attempt to reconnect.</p>

## Preparation for Operation

If you haven't already done so, detach the bottom cover, remove the 4-in-1 HEPA filter from the plastic bag, and install it in the unit. Replace the bottom cover.

## WiFi Setup

When you first turn on the unit, it will attempt to connect to your WiFi network. Follow these steps to connect your unit.

1. On your smartphone, install the **AiLivin** app and turn your Bluetooth function on.
2. Turn on the power to the unit.
3. Open the **AiLivin** app and add the device.
4. When the app indicates, press and hold the WiFi Status Indicator/button for 3 seconds.
5. The app should connect to the device over your WiFi network and the WiFi Status Indicator/Button will illuminate green.

*To disconnect from the network, press the WiFi Status Indicator/Button. The unit will beep and the indicator will flash red.*

## Operating Modes

There are three operating modes for the Purifier. When the Purifier is turned on, the mode of operation will return to the mode used the last time it was operated.

- **Normal Mode**

In Normal mode the Purifier operates at a fixed fan speed. Press this button repeatedly to toggle the fan speed between 1-2-3 speeds.

- **Auto Mode**

In Auto mode, the fan speed is automatically adjusted to correspond to the air quality detected by the sensor. If the sensor detects poor air quality, the fan speed will be adjusted higher. As the air quality improves, the fan speed will be adjusted lower.

- **Sleep Mode**

In Sleep mode, the fan speed is reduced to an ultra slow speed to minimize fan noise, and the light ring is turned off.

## Using the Remote Control

The Remote Control duplicates the functions of the corresponding buttons on the Control Panel. As Figure 3 showed, the power ON/OFF button, Auto Mode button, Timer button, Sleep Mode button, and Fan Speed buttons perform the same functions as the buttons on the Control Panel. Note: Operating range of the remote is approximately 16 feet.

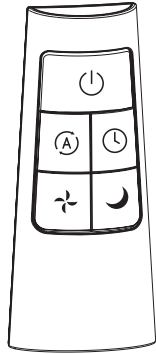

Figure 3. Remote Control

## Operating Alerts

As the Purifier operates, the following alerts may be displayed.

- **Filter Replacement Indicator/ Button**

- **Steady Red:** 4-in-1 HEPA filter should be replaced.

## Using the AiLivin App



The **AiLivin** app allows you to control, schedule, monitor, and customize your settings for the CleanAire 4 in 1 HEPA-PLASMA Air Purifier from your mobile device over your WiFi network. The **AiLivin** app can be downloaded to your smartphone from the Apple app store or Google Play.

WiFi is enabled by default on WiFi equipped units. Verify that your mobile device is compatible with the app, switched on, connected to a Wi-

### Air Quality Light Ring

- **Flashing blue with buzzer:** Bottom cover not in place.
- **Flashing red with buzzer for 5 times, then stop working:** Internal motor error.
- **Flashing red with buzzer, buzzer 2 times every 10s, the unit keep working:** Air quality sensor error.

Fi network with Bluetooth® wireless technology enabled.

If you do not already have the **AiLivin** app you will need to download it from the App Store or Google Play (Please scan QR code below), or CleanAire website.



AiLivin In Google Play



AiLivin In APP Store



Follow these instructions to use the **AiLivin** app.

1. Plug in your machine to the electrical outlet and turn on the power.
2. To disable or enable the WiFi press and hold the ON/OFF button on the machine for 3 seconds.
3. Open the **AiLivin** app and follow the instructions to create a new account if you do not already have one.
4. Follow the on-screen instructions to pair your machine to the **AiLivin** app. You will now be able to use the **AiLivin** app to create custom settings, monitor information from the machine, control your machine, schedule use and also keep up to date with system upgrades.

### Using the Schedule Function

**NOTE: The Schedule function is only available on the CAHP-05XX02C (WiFi equipped) model via the AiLivin App.**

Using the **AiLivin** App operation you can set up a Schedule to turn the CleanAire

4 in 1 HEPA-PLASMA Air Purifier On or Off time (like an alarm clock) in advance. You can Schedule when the unit will turn on and off. You can also set up the desired operating mode—including plasma on/off function, fan speed, auto mode or sleep mode. For example, if you set the machine on at 22:30 in sleep mode, it will be turned on immediately at 22:30 at night and enter the sleep mode.

### Voice Control

You can use the **AiLivin** app to connect your voice equipment for the control, following the instruction codes your voice equipment have.

If you experience problems downloading the **AiLivin** app or pairing with your device, first check that you are connected to a WiFi network and Bluetooth® wireless technology is enabled on your mobile device and try again. If you continue to experience problems, please contact Customer Assistance.

## Filter Replacement

### 4-in-1 HEPA Filter Replacement

The filter should be replaced every 18 months or whenever indicated by the Filter Replacement Indicator/Button on the Control Panel. However this interval is intended as a guideline only. In environments with a high concentration of contaminants such as dust, pet dander, or cigarette/cigar smoke you may need to replace the filter more frequently.

**NOTE: The filter is not washable. DO NOT immerse it in water.**

1. Make sure the Purifier is OFF and unplugged.
2. Detach and remove magnetic bottom cover from the unit.
3. Remove and replace the replacement 4-in-1 HEPA filter into the Purifier chassis.

**NOTE: Ensure that the pull tabs are facing outward to facilitate filter removal later.**

4. Inspect the screen on the bottom cover and if necessary clean any excess dust or dirt from the screen using a hand held vacuum.
5. Replace the bottom cover by placing the bottom cover into the slots on the unit. Gently push the top of the bottom cover into place.
6. Turn on the Purifier. After replacing the filter, press and hold Filter Replacement Indicator/Button for 3 seconds to reset the filter life countdown.

1. Detach magnetic cover

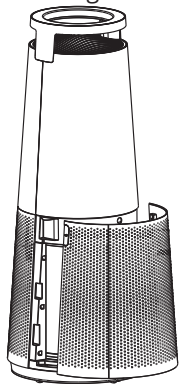

2. Remove and replace filter

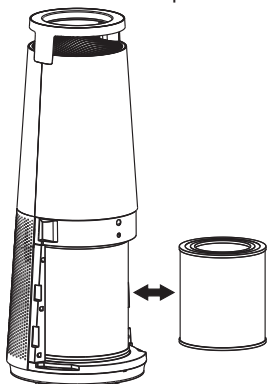

3. Replace magnetic cover



4. Press and hold Filter Replacement Indicator/button for 3 seconds to reset filter life countdown.

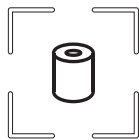

Figure 4. 4-in-1 HEPA Filter Replacement

## Remote Battery Replacement

**! WARNING** This product contains a lithium button/coin cell battery. If a new or used lithium button/coin cell battery is swallowed or enters the body, it can cause severe internal burns and can lead to death in as little as 2 hours. If you think batteries might have been swallowed or placed inside any part of the body, seek immediate medical attention.

1. Remove the screw and battery compartment cover.
2. Remove coin battery and dispose of properly.
3. Insert replacement battery.
4. Install battery compartment cover and secure with screw.

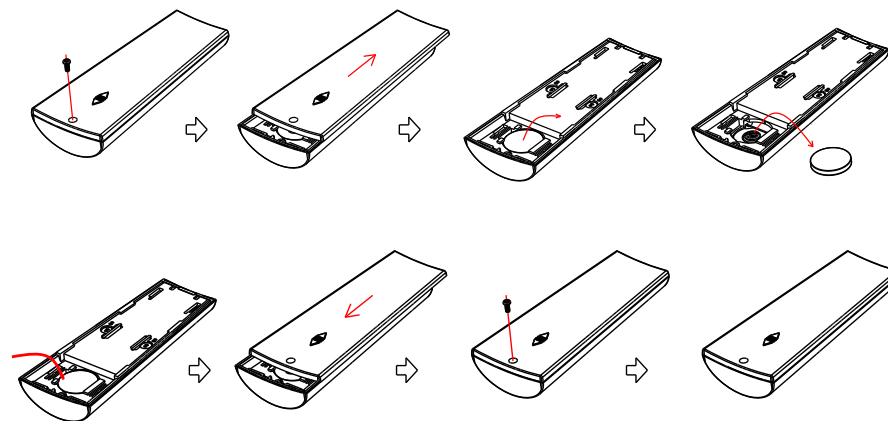

Figure 5. Remote Battery Replacement

Troubleshooting	
Symptom	Probable Cause/Solution
Purifier does not operate.	Power cord not securely plugged into outlet. Make sure plug is securely inserted.
	No AC power. Check fuse or circuit breaker. Replace fuse with a time delay type or reset the circuit breaker.
Purifier is starting to make noise and the air output is low.	4-in-1 HEPA filter may be dirty or obstructed. Replace filter.
Air coming from Purifier has a bad odor.	The first time you use the purifier, you might perceive a plastic or paint smell. This is normal, but it should disappear quickly. If the smell persists or if you sense a burning smell, please disconnect the purifier and contact Customer Assistance.
Air quality does not improve as the Purifier operates.	Windows or doors are open. Constant introduction of dirty air from outside the room can reduce the effectiveness of the Purifier. Close all exterior doors and windows.
Fan does not operate.	Bottom cover is not securely in place. Ensure that the bottom cover is closed properly, and the filter is properly installed.
Fan speed does not change after selecting a new fan speed.	The fan speed will decrease or increase gradually, this is normal. If fan speed does not change after a prolonged period of time after changing the setting contact Customer Assistance.

Troubleshooting	
Symptom	Probable Cause/Solution
The appliance is very loud.	Ensure that there are no obstacles near the appliance and that it has a minimum of 12 inches (30 cm) of clearance around it for optimal operation.
The app does not operate properly or it is not possible to sync the Purifier with the <b>AIvivi</b> smartphone app.	Contact Customer Assistance.

## Cleaning and Maintenance

- When the device is not used for an extended time, store it in a cool dry place. Do not store the device where it might be exposed to excess moisture or direct sunlight. The device may not operate effectively in very low temperatures. The device can be damaged when exposed to sub-freezing temperatures.
- Use a dry cloth to clean the exterior of the device. Do not use any chemicals or cleaners.

shown in Figure 6. Every 2 months you should clean the inlet using a vacuum or with a cotton swab that has been lightly moistened with clean water.

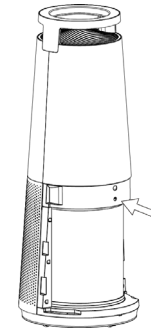

**Figure 6. Air Quality Sensor**

### Cleaning the Air Quality Sensor

The inlet for the air quality sensor is located on the back of the machine as

## Customer Assistance

For assistance with your CleanAire 4 in 1 HEPA-Plasma Air Purifier, call our Customer Service Line:

1-855-384-7754  
8 a.m. - 5 p.m., CST, Monday – Friday

Dernier and Hamlyn Inc.  
720 Northgate Parkway  
Wheeling, IL 60090

## PRODUCT WARRANTY

A. This 2 year limited warranty applies to repair or replacement of product found to be defective in material or workmanship. This warranty does not apply to damage resulting from commercial, abusive, unreasonable use or supplemental damage. Defects that are the result of normal wear and tear will not be considered manufacturing defects under this warranty. **D&H IS NOT LIABLE FOR INCIDENTAL OR CONSEQUENTIAL DAMAGES OF ANY NATURE, ANY IMPLIED WARRANTY OF MERCHANTABILITY OR FITNESS FOR A PARTICULAR PURPOSE ON THIS PRODUCT IS LIMITED IN DURATION TO THE DURATION OF THIS WARRANTY.** Some jurisdictions do not allow the exclusion or limitation of incidental or consequential damages or limitations on how long an implied warranty lasts, so the above limitations or exclusions may not apply to you. This warranty gives you specific legal rights, and you also may have other rights which vary from jurisdiction to jurisdiction. This warranty applies only to the original purchaser of this product from the original date of purchase.

B. At its option, D&H will repair or replace this product if it is found to be defective in material or workmanship.

C. This warranty does not cover damage resulting from any unauthorized attempts to repair or from any use not in accordance with the instruction manual.

D. This warranty does not cover the filter except for material or workmanship defects.

Apple and the Apple logo are trademarks of Apple Inc., registered in the U.S. and other countries. App Store is a service mark of Apple Inc., registered in the U.S. and other countries.

Google Play and the Google Play logo are trademarks of Google Inc.

The Bluetooth® word mark and logos are registered trademarks owned by the Bluetooth SIG, Inc. and any use of such marks is under license.

## FCC STATEMENT

Product Name: 4 in 1 HEPA-Plasma Air Purifier

Model No.: CAHP-50XX02 (without WiFi)

CAHP-50XX02C (with WiFi)

Note: XX is the color code.

Trade Mark: CleanAire

This device complies with related rules, operation is subject to the following two conditions.

(1) This device may not cause harmful interference and,

(2) This device must accept any interference received, including interference that may cause undesired operation.

It is understood that each unit marketed is identical to the device as tested, and any changes to the device that could adversely affect the emission characteristics will require retest.

The following responsible party is responsible for this declaration:

Company Name: ETi Solid State Lighting, Inc. Company

Address: 720 Northgate Parkway, Wheeling, Illinois, 60090

Telephone Number: 1-855-384-7754



This product earned the ENERGY STAR by meeting strict energy efficiency guidelines set by the US EPA. US EPA does not endorse any manufacturer claims of healthier indoor air from the use of this product. The energy efficiency of this ENERGY STAR qualified model is measured based on a ratio between the model's CADR for Dust and the electrical energy it consumes, or CADR/Watt.



#### FCC statement

This device complies with Part 15 of the FCC rules. Operation is subject to the following two conditions: 1) this device may not cause harmful interference, and 2) this device must accept any interference received, including interference that may cause undesired operation.

Note: This equipment has been tested and found to comply with the limits for a Class B digital device, pursuant to part 15 of the FCC Rules. These limits are designed to provide reasonable protection against harmful interference in a residential installation. This equipment generates uses and can radiate radio frequency energy and, if not installed and used in accordance with the instructions, may cause harmful interference to radio communications. However, there is no guarantee that interference will not occur in particular installation. If this equipment does cause harmful interference to radio or television reception, which can be determined by turning the equipment off and on, the user is encouraged to try to correct the interference by one or more of the following measures:

--Reorient or relocate the receiving antenna.

--Increase the separation between the equipment and receiver.

--Connect the equipment into an outlet on a circuit different from that to which the receiver is connected.

--Consult the dealer or an experienced radio/TV technician for help.

Changes or modifications not expressly approved by the party responsible for compliance could void the user's authority to operate the equipment.

#### FCC Radiation Exposure Statement

This device complies with FCC RF radiation exposure limits set forth for an uncontrolled environment. This transmitter must not be co-located or operating in conjunction with any other antenna or transmitter.

#### IC

The licensed transmitter/receiver contained in this device is compliant with Innovation, Science and Economic Development Canada's RNC for licensed radio devices. The operation is permitted under two conditions:

1. The device must not cause interference;

2. The device must accept any radio interference, even if the interference is likely to compromise its operation.

#### RF exhibition statement:

The equipment complies with the IC radiation exposure limit established for an uncontrolled environment.

This equipment must be installed and used with a minimum

distance of 20 cm between the radiator and your body.

L'émetteur/récepteur exempt de licence contenu dans le présent appareil est conforme aux CNR d'Innovation, Sciences et Développement économique Canada applicables aux appareils radio exempts de licence. L'exploitation est autorisée aux deux conditions suivantes :

1. L'appareil ne doit pas produire de brouillage;

2. L'appareil doit accepter tout brouillage radioélectrique subi, même si le brouillage est susceptible d'en compromettre le fonctionnement.

#### Déclaration d'exposition RF:

L'équipement est conforme à la limite d'exposition aux radiations de la IC établie pour un environnement non contrôlé. Cet équipement doit être installé et utilisé avec une distance minimale de 20mm entre le radiateur et votre corps.