



**DATE: 10 February 2016**

**I.T.L. (PRODUCT TESTING) LTD.  
FCC Radio Test Report  
according to Subpart H, Part 2  
for  
Runcom Technologies Ltd.**

**Equipment under test:**

**CPE (Customer Premises  
Equipment)**

**CPE-O-R-WS**

Tested by:

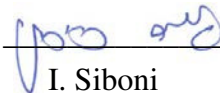

I. Siboni

Approved by:

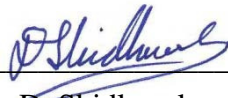

D. Shidlow

This report must not be reproduced, except in full, without the written permission of I.T.L. (Product Testing) Ltd.

This report relates only to items tested.



# Measurement/Technical Report for Runcom Technologies Ltd.

CPE (Customer Premises Equipment)

## CPE-O-R-WS

### FCC ID: XYMCPETVWS-1

This report concerns:	Original Grant: X
	Class I Change:
	Class II Change:
Equipment type:	WGF- White Space Device with Geo- location – Fixed
Limits used:	47CFR15 Subpart H White Spaces System

Measurement procedure used is ANSI C63.4-2009 and KDB 416721 D01  
White Space Test Procedures v 03

Application for Certification prepared by:	Applicant for this device: (different from "prepared by")
R. Pinchuck	Tzvi Marcu
ITL (Product Testing) Ltd.	Runcom Technologies Ltd.
1 Bat Sheva St.	11 Moshe Levi Street
Lod 7116002	Rishon Le Zion 754658
Israel	Tel: +972-3-942-8888
e-mail Rpinchuck@itl.co.il	Fax: +972-3-952-8805
	e-mail: Tzvim@runcom.co.il



# TABLE OF CONTENTS

<b>1.</b>	<b>GENERAL INFORMATION.....</b>	<b>4</b>
1.1	Administrative Information .....	4
1.2	List of Accreditations .....	5
1.3	Product Description .....	6
1.4	Test Methodology .....	6
1.5	Test Facility .....	6
<b>2.</b>	<b>SYSTEM TEST CONFIGURATION.....</b>	<b>7</b>
2.1	Justification.....	7
2.2	EUT Exercise Software .....	7
2.3	Special Accessories .....	7
2.4	Equipment Modifications .....	7
2.5	Configuration of Tested System .....	8
<b>3.</b>	<b>TEST SET-UP PHOTO.....</b>	<b>9</b>
<b>4.</b>	<b>§15.713(G)(3) – FIXED WSD REGISTRATION.....</b>	<b>10</b>
4.1	Successful Registration, 15.713(g)(3) – Fixed WSD with direct connection to Internet (Base Station) .....	10
4.2	Unsuccessful Registration, 15.713(g)(3) – FCC ID, Serial Number .....	12
4.3	Unsuccessful Registration, 15.713(g)(3) – Restricted Co-ordinates.....	13
4.4	Unsuccessful Registration, 15.713(f)(3) – Antenna Height AGL> 30m .....	14
4.5	Unsuccessful Registration, 15.713(g)(3) – Incomplete Contact Information .....	15
4.6	Successful Registration, 15.713(g)(3) – Fixed WSD without a direct connection to Internet (CPE) .....	16
<b>5.</b>	<b>§15.711(H) FIXED DATABASE UPDATE.....</b>	<b>17</b>
5.1	Test Procedure: .....	17
5.2	Test Results: .....	17
<b>6.</b>	<b>§15.711(C)(2)(III), §15.713(A)(1) 48 HOUR CHANNEL SCHEDULING.....</b>	<b>18</b>
6.1	Test Purpose .....	18
6.2	Test Procedure: .....	18
6.3	Test Result: .....	18
<b>7.</b>	<b>§15.707, §15.711(C), (D), §15.712 WSD CHANNEL AVAILABILITY.....</b>	<b>20</b>
7.1	Test Purpose: .....	20
7.2	Test Procedure: .....	20
7.3	Test Result: .....	20
<b>8.</b>	<b>§15.715(F), §15.713(L); §15.711(J) SECURITY.....</b>	<b>22</b>
<b>9.</b>	<b>§15.711(I) PUSH NOTIFICATION TO FIXED.....</b>	<b>23</b>
<b>10.</b>	<b>§15.711(B) LOCATION ACCURACY.....</b>	<b>23</b>
<b>11.</b>	<b>§15.712 INTERFERENCE PROTECTION REQUIREMENTS (FIXED).....</b>	<b>23</b>
<b>12.</b>	<b>§15.711(C )(2)(II), (D)(3), §15.715(E ) FIXED POWER LEVEL REDUCTION.....</b>	<b>23</b>
<b>13.</b>	<b>APPENDIX 1 – CUSTOMER’S DECLARATION.....</b>	<b>24</b>



# 1. General Information

## 1.1 Administrative Information

Manufacturer:	Runcom Technologies Ltd.
Manufacturer's Address:	11 Moshe Levi St. Rishon Le Zion 75658 Israel Tel: +972-3-952-8440 Fax: +972-3-952-8805
Manufacturer's Representative:	Tzvi Marcu
Equipment Under Test (E.U.T):	CPE (Customer Premises Equipment)
Equipment Model No.:	CPE-O-R-WS
Equipment Serial No.:	Not designated
Date of Receipt of E.U.T:	20.04.2015
Start of Test:	20.04.2015
End of Test:	30.04.2015
Test Laboratory Location:	I.T.L (Product Testing) Ltd. 1 Batsheva St., Lod ISRAEL 7120101
Test Specifications:	FCC Part 15, Subpart H, Part 2



## 1.2 **List of Accreditations**

The EMC laboratory of I.T.L. is accredited by the following bodies:

1. The American Association for Laboratory Accreditation (A2LA) (U.S.A.), Certificate No. 1152.01.
2. The Federal Communications Commission (FCC) (U.S.A.), FCC Designation No. IL1005.
3. The Israel Ministry of the Environment (Israel), Registration No. 1104/01.
4. The Voluntary Control Council for Interference by Information Technology Equipment (VCCI) (Japan), Registration Numbers: C-3006, R-2729, T-1877, G-245.
5. Industry Canada (Canada), IC File No.: 46405-4025; Site No. IC 4025A-1, IC 4025A-2.

I.T.L. Product Testing Ltd. is accredited by the American Association for Laboratory Accreditation (A2LA) and the results shown in this test report have been determined in accordance with I.T.L.'s terms of accreditation unless stated otherwise in the report.

### **1.3 Product Description**

The TV White Space (TVWS) system is a broadband wireless access solution that Runcom offers to its customers.

The purpose of Runcom's TVWS solution is to provide Point-to-Multipoint Broadband Internet services to locations that are hard to reach by standard wireless solutions.

The Target customers for this TVWS solution are Wireless Internet Services Providers (WISPs) in rural and remote areas that need to provide broad band Internet services to customers that are beyond trees, hills or other obstacles that prevent from the standard Line of Sight (LOS) wireless solutions to provide a reliable connectivity.

The CPE-O-R-WS is the component in the TVWS solution that is installed at the customer houses/premises. It is connected on one side to the Internet cloud via wireless (through the Base Station) and on the other side to the customer's terminals (such as computers, laptops, WiFi AP's, video games, appliances, etc) that needs IP connectivity.

### **1.4 Test Methodology**

Radiated testing was performed according to the procedures ANSI C63.4: 2009 and KDB 416721 D01 White Space Test Procedures v 03.

Radiated testing was performed at an antenna to EUT distance of 1 and 3 meters.

### **1.5 Test Facility**

Radiated emissions tests were performed at I.T.L.'s testing facility in Lod, Israel. I.T.L.'s EMC Laboratory is accredited by A2LA, certificate No. 1152.01 and its FCC Designation Number is IL1005.



## 2. System Test Configuration

### 2.1 ***Justification***

The E.U.T. was tested in installation position with power strength and modulation reflecting actual set up.

### 2.2 ***EUT Exercise Software***

The E.U.T. was supplied with special software that enabled control of the data received from WSDB registration interface.

### 2.3 ***Special Accessories***

No special accessories were needed to achieve compliance.

### 2.4 ***Equipment Modifications***

No modifications were necessary in order to achieve compliance.

## 2.5 Configuration of Tested System

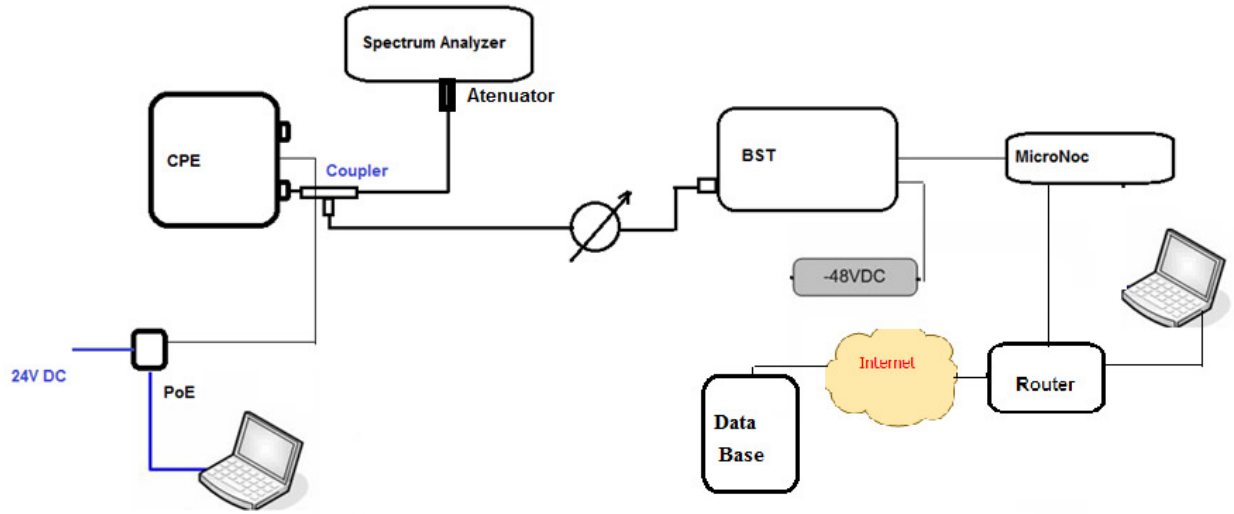

Figure 1. Configuration of Tested System

### 3. Test Set-up Photo

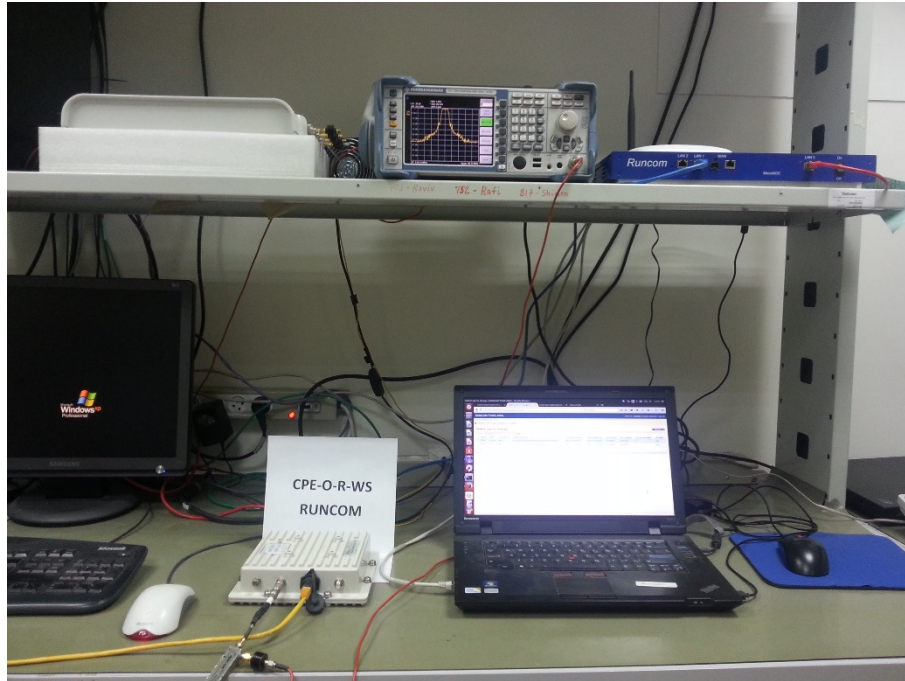

Figure 2. Test Set Up

## 4. §15.713(g)(3) – Fixed WSD Registration

### 4.1 **Successful Registration, 15.713(g)(3) – Fixed WSD with direct connection to Internet (Base Station)**

#### 4.1.1 **Test Procedure:**

Configure the EUT with the required registration information. Verify the required registration information is sent and stored in the white space data base.

Successful registration should be verified by accessing the WSDB registration interface and also the EUT status information page.

The tested parameters which confirmation of receipt was received from the base station were:

1. FCC id;
2. Serial Number;
3. Location coordinates;
4. Location uncertainty with 95 % accuracy;
5. Antenna Height AGL ( must not be > 30 m)
6. Contact informations (device owener and device contact)

#### 4.1.2 **Test Pre-Conditions:**

The FCC ID and the serial # of the radio are programmed in the firmware of the radio and cannot be modified with the EUT configuration web tool. A known acceptable location was put into the WSD. The WSD was configured as follows and the information submitted for registration to the WSD.

#### 4.1.3 **Test Results:**

JUDGEMENT:       PASS

The registration request and the response for the successful registration were seen on the WSD GUI, *Figure 3*.

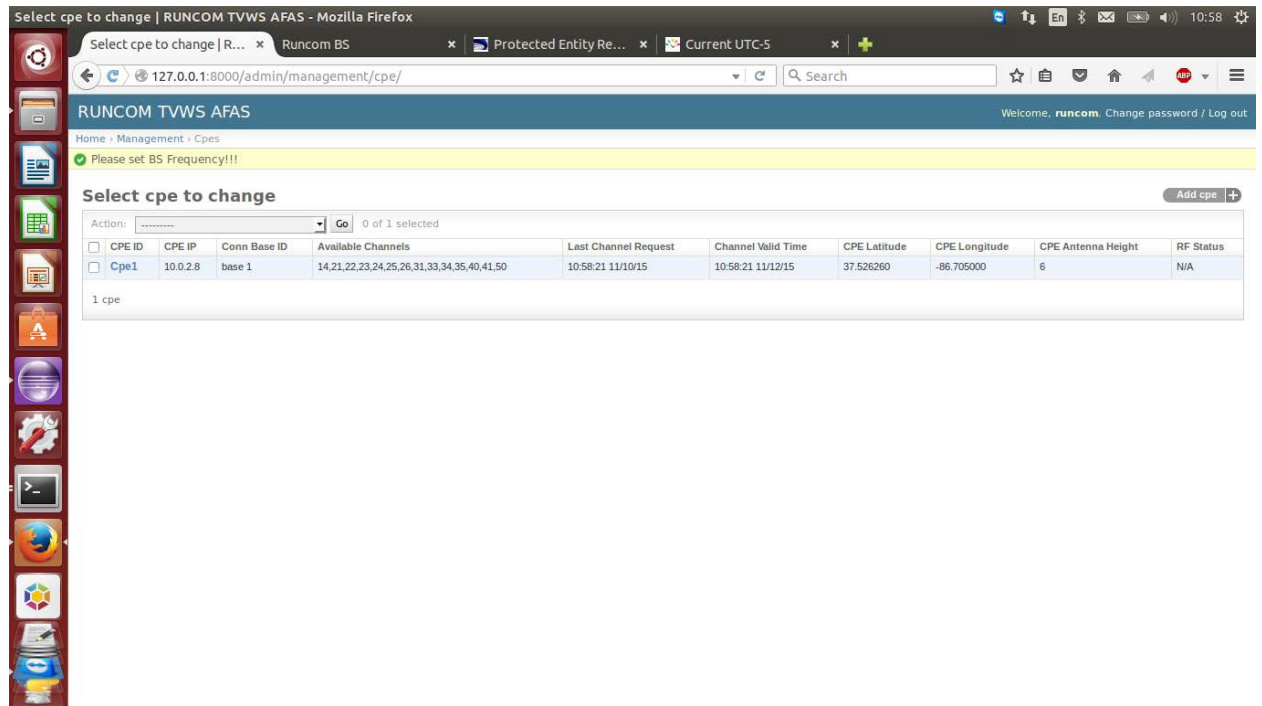

Figure 3. WSD GUI

## 4.2 **Unsuccessful Registration, 15.713(g)(3) – FCC ID, Serial Number**

### 4.2.1 Test Procedure

Configure the EUT with Incomplete Information (e.g. wrong serial number). Verify the required registration information is sent and stored in the white space data base. Registration failure should be verified by accessing the WSD registration interface and also the EUT GUI.

### 4.2.2 Test Preconditions

An incorrect serial number was entered in the EUT GUI.

### 4.2.3 Test Results

JUDGEMENT: PASS

The failed registration with the reason for failure can be seen on the WSD GUI below, *Figure 4*.

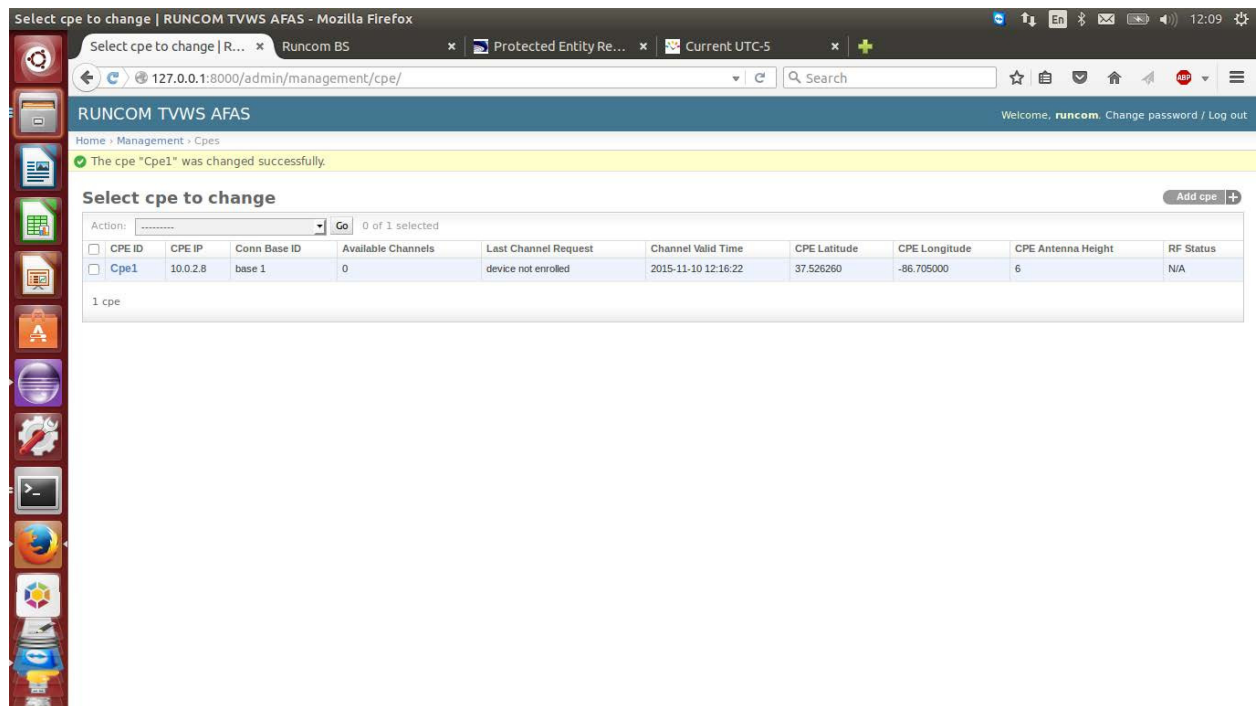

Figure 4. WSD GUI

### 4.3 **Unsuccessful Registration, 15.713(g)(3) – Restricted Co-ordinates**

#### 4.3.1 **Test Procedure:**

Configure the EUT with restricted co-ordinates (Outside US Regulatory boundaries, example 31.5, -106.9). Verify the required registration information is sent and stored in the white space data base.

Registration failure should be verified by accessing the WSD registration interface and also the EUT GUI.

#### 4.3.2 **Test Pre-Conditions:**

A location outside US regulatory boundaries (31.5, -106.9) was entered into the radio and the information submitted for registration to the WSD.

#### 4.3.3 **Test Results:**

JUDGEMENT:        PASS

The failed registration with the reason for failure can be seen on the WSD GUI below, *Figure 5*.

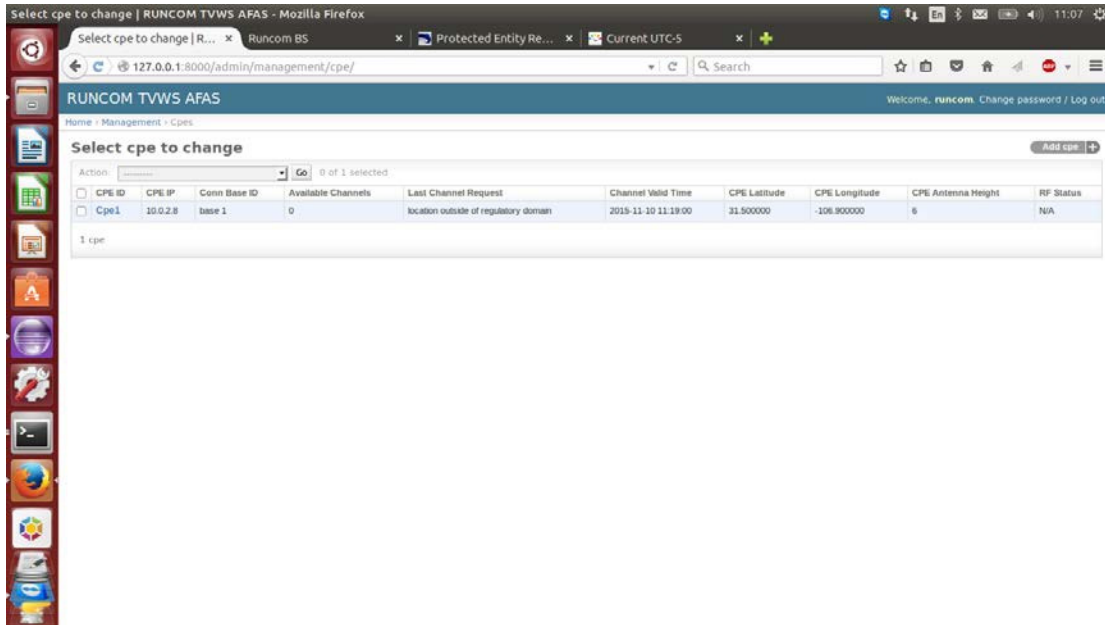

**Figure 5. WSD GUI**

#### 4.4 **Unsuccessful Registration, 15.713(f)(3) – Antenna Height AGL> 30m**

##### 4.4.1 **Test Procedure:**

Configure the EUT with such that AGL>30m. Verify the required registration information is sent and stored in the white space data base.

Registration failure should be verified by accessing the WSD registration interface and also the EUT status web page.

##### 4.4.2 **Test Pre-Conditions:**

Antenna height = 32 m was entered into the radio and the information submitted for registration to the WSD.

##### 4.4.3 **Test Results:**

JUDGEMENT: PASS

The failed registration with the reason for failure can be seen on the TVBD GUI below, *Figure 6.*

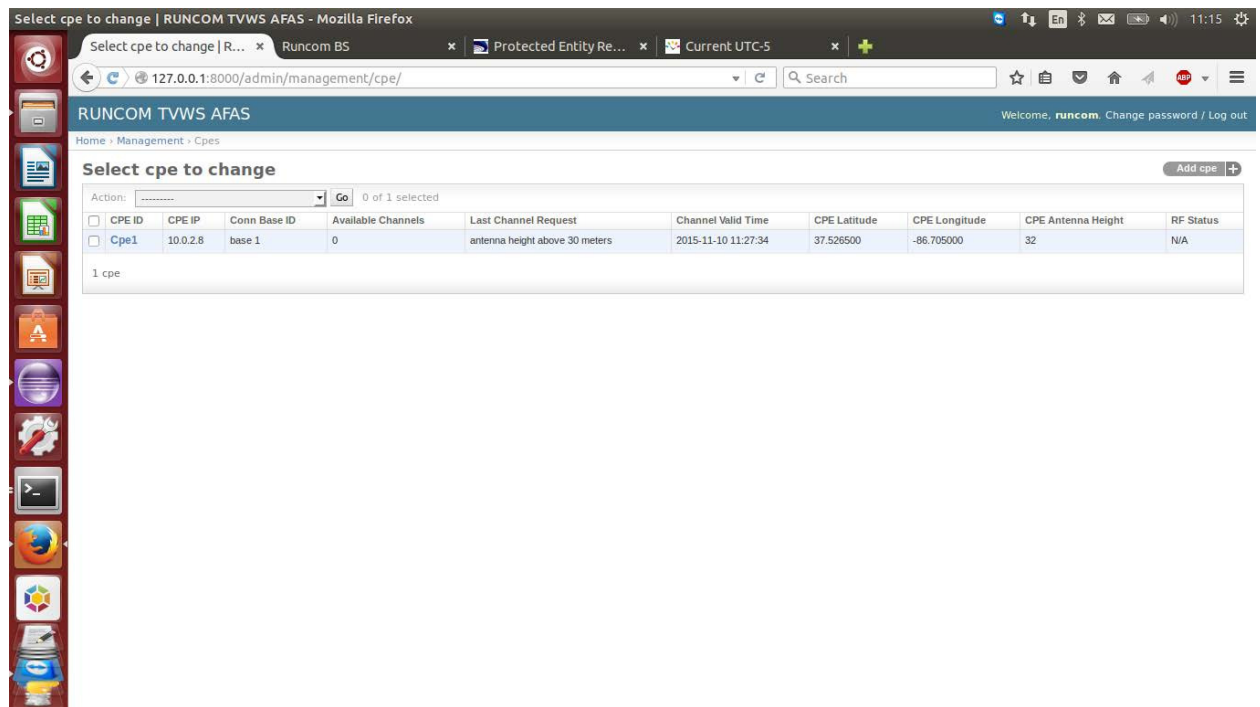

**Figure 6. WSD GUI**

The transmitter did not turn ON. Spectrum analyzer was used to verify no transmission.

## 4.5 Unsuccessful Registration, 15.713(g)(3) – Incomplete Contact Information

### 4.5.1 Test Procedure:

Configure the EUT with Incomplete Information (e.g. Contact information). Verify the required registration information is sent and stored in the white space data base. Registration failure should be verified by accessing the WSD registration interface and also the EUT GUI.

### 4.5.2 Test Pre-Conditions:

The ‘Contact Name’ Information field should be left blank.

### 4.5.3 Test Results:

JUDGEMENT: PASS

The WSD GUI shown below, *Figure 7* confirms the failed registration. No registration request was sent to the WSD. All combinations of missing information were tried and the behavior verified. The WSD does not send a registration request to WSD with missing contact information. The transmitter did not turn ON. Spectrum analyzer was used to verify no transmission.

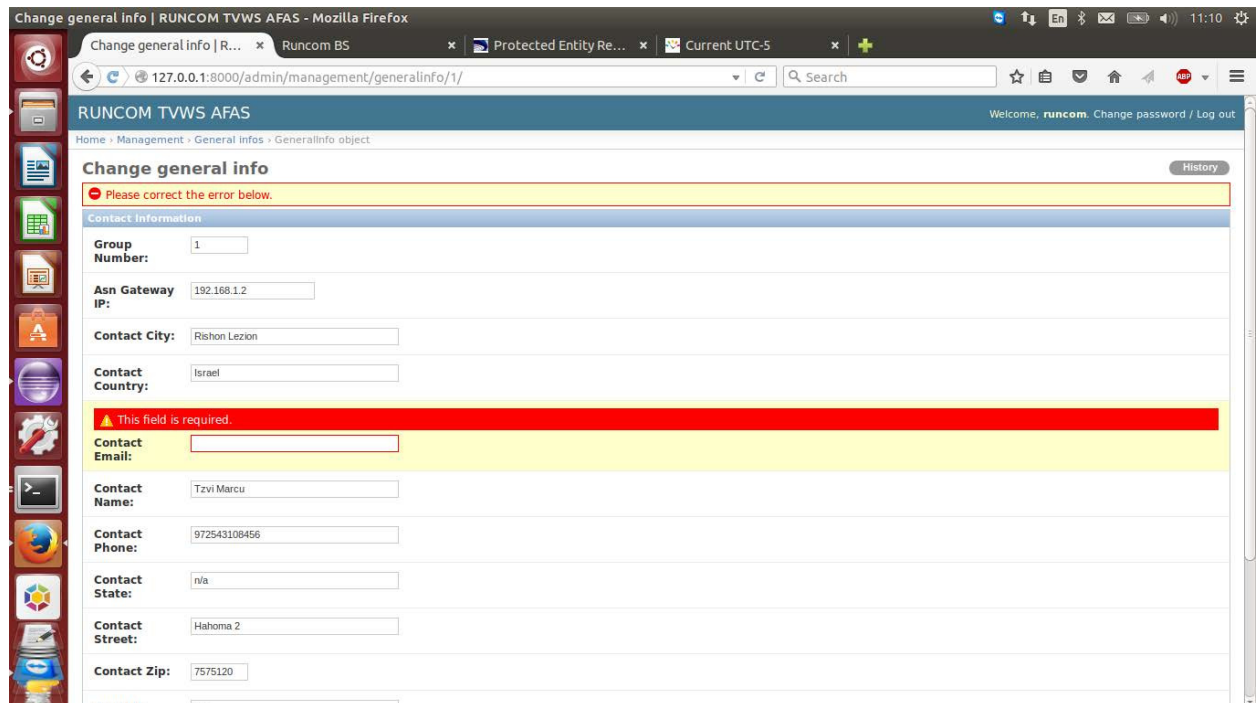

Figure 7. WSD GUI

#### 4.6 **Successful Registration, 15.713(g)(3) – Fixed WSD without a direct connection to Internet (CPE)**

##### 4.6.1 Test Procedure:

Configure the EUT with the required registration information. Verify that the required registration information is sent and stored in the white space data base. Operating channel should be verified on the CPE (radio without the internet connections) using the EUT GUI.

##### 4.6.2 Test Pre-Conditions:

The Base station WSD was configured and the information submitted for registration to the WSD. The CPE operating channel was verified with the GUI and via connecting the output to a spectrum analyzer.

##### 4.6.3 Test Results:

JUDGEMENT: PASS

The registration request and the response for the successful registration were seen on the WSD GUI for the CPE, *Figure 8*.

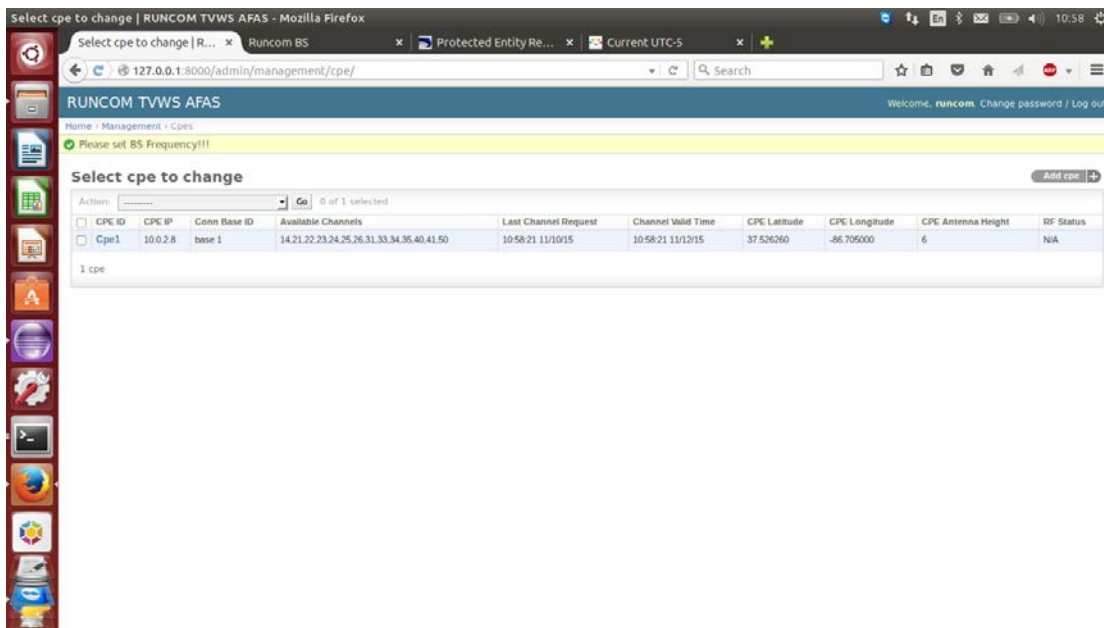

Figure 8. WSD GUI

The WSD GUI shown above confirms the successful registration of the CPE. Operating Channel is 14. The transmitter did not turn ON until the database exchange was successfully completed. This was confirmed by monitoring the output signal of the E.U.T. via the spectrum analyzer.

## 5. §15.711(h) Fixed Database Update

### 5.1 Test Procedure:

Using a programmable router or similar network device, block the access to the database URL or IP address from the WSD. Confirm that the WSD shuts down by 11:59 PM on the following day.

Configure the fixed device with a location that will yield an authorized channel list. Verify proper channel operation using a spectrum analyzer and the device management interface.

Restrict the access to the database.

Verify that the device does not transmit using white space frequencies after 11:59 PM the following day. Verify using a spectrum analyzer and the device management interface.

### 5.2 Test Results:

JUDGEMENT: PASS

**The device is configured to shut down by 11:59 PM on the following day if access to the database is blocked.**

The device was initially powered up and it successfully registered with the database at approximately 5:30 PM. The device received a channel list and started transmitting on channel 14. The connection to the database was then blocked, while maintaining regular access to the internet. See *Figure 9*.

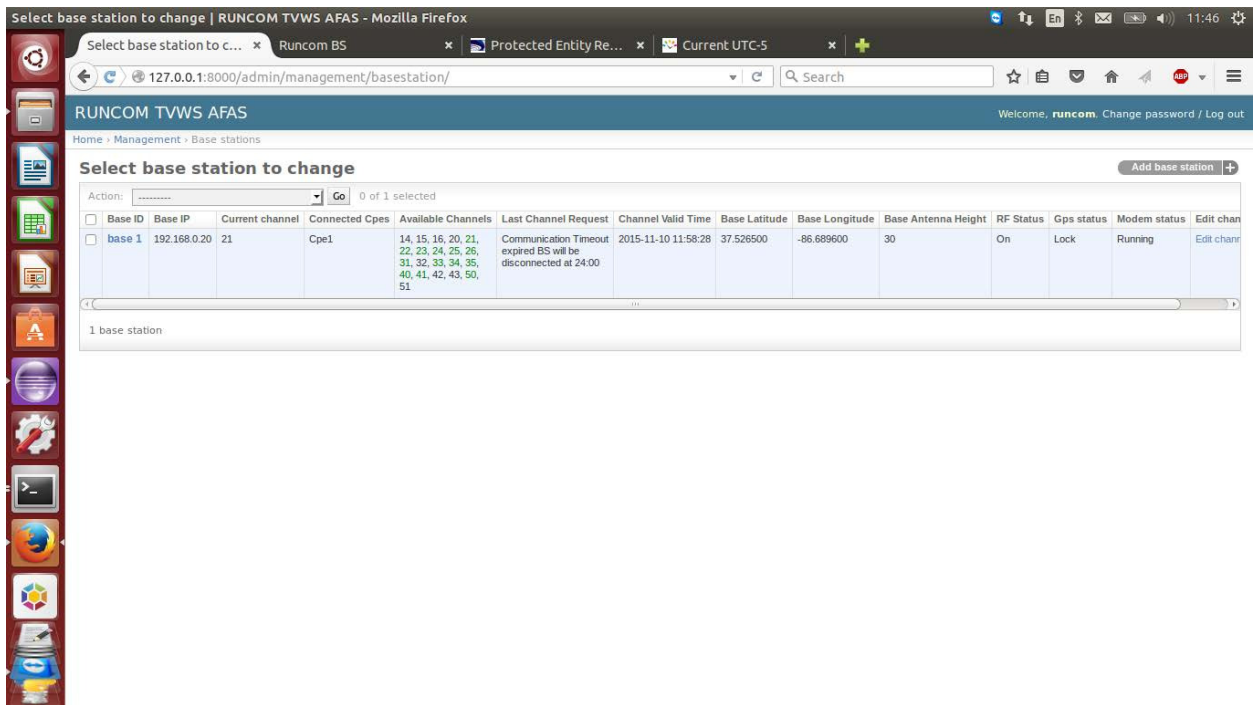

Figure 9. WSD GUI



## 6. §15.711(c)(2)(iii), §15.713(a)(1) 48 Hour Channel Scheduling

### 6.1 **Test Purpose**

Use the database interface to register protection for a low-power auxiliary device for the same location and channel on which the WSD (EUT) has selected and is operating. The registered protection for the low-power auxiliary device should be scheduled for protection within the next 48 hour period.

### 6.2 **Test Procedure:**

Configure the WSD (EUT) such that it can access the database.

Verify that EUT requests and receives a valid channel list. Verify the EUT is using an authorized channel using a spectrum analyzer and the device management interface.

Use the database interface to register protection for a low-power auxiliary device for the same location and channel on which the WSD (EUT) has selected and is operating. The registered protection for the low-power auxiliary device should be scheduled for protection within the next 48 hour period.

Verify that the EUT requests and receives a new channel list at the scheduled time of the registered low-power channel protection is to take effect.

Verify the new channel map does not contain the channel previously protected when the low-power auxiliary device was registered.

Verify the EUT is operating on a different channel from what was previously used and subsequently reserved using a spectrum analyzer and the device management interface.

### 6.3 **Test Result:**

JUDGEMENT:       PASS

See *Figure 10* for additional information.

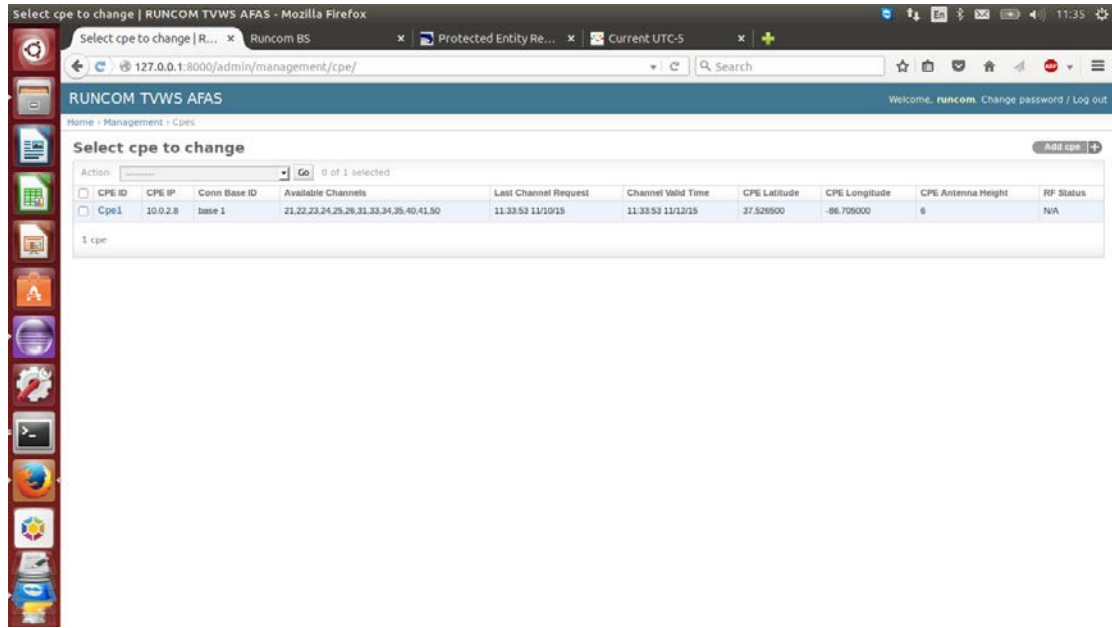

Figure 10. – WSD GUI

## 7. §15.707, §15.711(c), (d), §15.712 WSD Channel Availability

### 7.1 **Test Purpose:**

Confirm that the channel list provided by the database conforms with those allowable to the class of WSD under test. Confirm that the WSD is operating on a channel from the list at authorized power and cannot be made to operate on an unauthorized channel.

### 7.2 **Test Procedure:**

Register the WSD with valid location information.

Verify that the channel list provided by the WSD conforms to the device type of the WSD under test.

Configure and register the devices location (N. 33.620700 W. -100.322800) such that the database returns a channel list that does not allow operation on any channel.

Use a spectrum analyzer to verify that the EUT does not transmit on any white space channel.

Verify that the EUT does not transmit on any channel until it successfully registers and receives a channel list.

### 7.3 **Test Result:**

JUDGEMENT:       PASS

The database identified the device type correctly and the channel list provided is correct for the device type. For additional information see *Figure 11*.

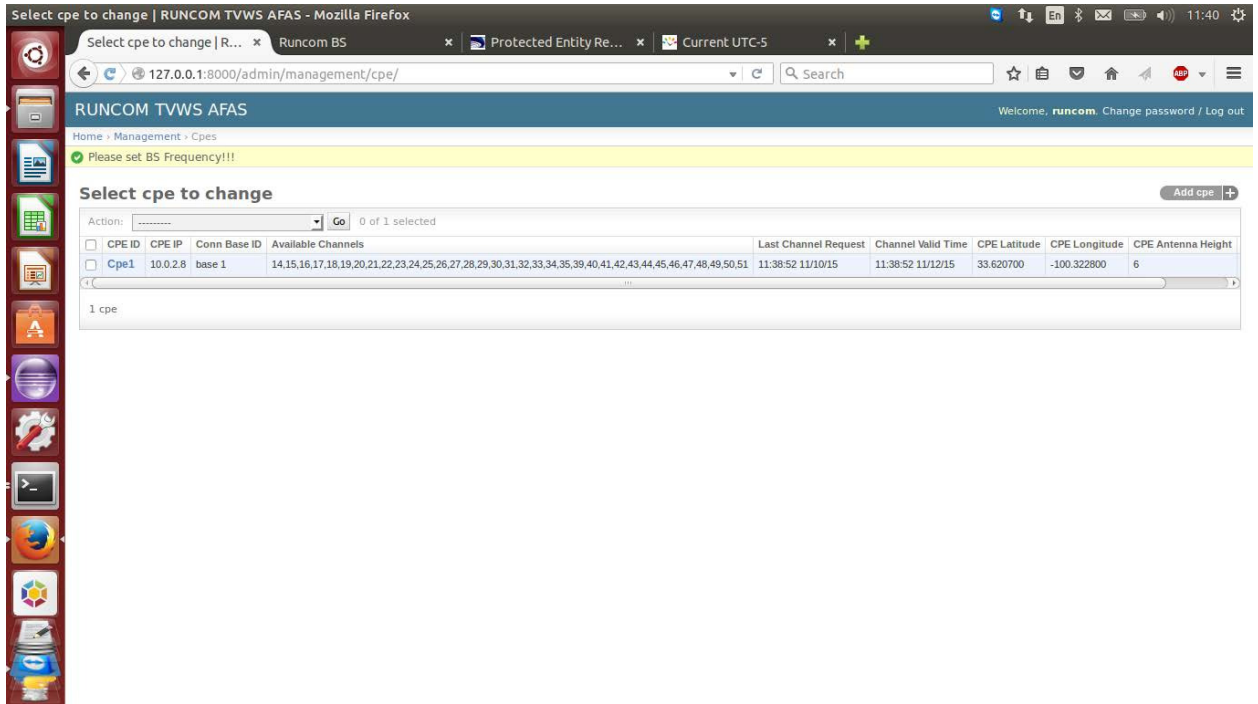

Figure 11. WSD GUI

## 8. §15.715(f), §15.713(l); §15.711(j) Security



### Attachment- 1

#### CPE-O-R-WS Connection with Spectrum Bridge Database Security

Connection security is accomplished in a multi-layered approach

Device Enrollment - At first each CPE-O-R-WS serial numbers is enrolled with Spectrum Bridge database prior to shipment.

Devices that contact the database through the AFAS (Automatic Frequency Allocation Software) are authenticated against the FCC database FCCID and the enrollment list. Only devices that pass both tests are serviced by Spectrum Bridge database.

All other mandatory parameters in the registration message and channel request messages must be correct.

Location is checked and registered manually by a Runcom certified installation engineer and must be within the FCC jurisdiction.

CPE-O-R-WS is a fixed device so if its location changes in future requests the CPE-O-R-WS will not be serviced until it registers with new location.

i- Protocol - Communication is via HTTPS secured protocol and uses various internet protocol security mechanisms.

ii- Communication Initiation - Communication is initiated by CPE-O-R-WS related AFAS server establishing a session and registering with the database.

iii- Validation - Communication is via a pre-configured (in firmware) URL – the CPE-O-R-WS AFAS is programmed to only talk to the certified database.

Software provided by the Database (Agent) validates the correct format of messages from the database.

iv- Communication Failure - If the CPE-O-R-WS AFAS fails to communicate with the database CPE-O-R-WS will carry on to operate and related AFAS will continue to contact the database for T update. If the CPE-O-R-WS AFAS fails to contact the database within T update it will cease CPE-O-R-WS transmission until it establishes a connection with the database and receives a response to a channel request.

v- Data Validation from WSD- See first paragraph above

vi- Encryption – See paragraph I above

vii- Link security - Registration can only be accomplished via the secure Internet connection and only by the electronic communication between the database and the CPE-O-R-WS related AFAS.

Thank you,

Tzvi Marcu,  
Technical Support Manager



## **9. §15.711(i) Push Notification to Fixed**

See Answer in Section 2 of customer Declaration -01 located in Appendix A of this report.

## **10. §15.711(b) Location Accuracy**

See Answer in Section 3 of customer Declaration -01 located in Appendix A of this report.

## **11. §15.712 Interference Protection Requirements (Fixed)**

See Answer in Section 4 of customer Declaration -01 located in Appendix A of this report.

## **12. §15.711(c )(2)(ii), (d)(3), §15.715(e ) Fixed Power Level Reduction**

See Answer in Section 5 of customer Declaration -01 located in Appendix A of this report.

## 13. Appendix 1 – Customer's Declaration



2 Hachoma Street, 2<sup>nd</sup> Floor  
Rishon Lezion, Israel, 7565502  
[info@runcom.com](mailto:info@runcom.com);  
[www.runcom.com](http://www.runcom.com)  
Tel: +972-3-9528874  
Fax: +972-3-9528805

### Declaration -01

Please find response to the clarifications requests below:

1. Please amend the operational description to include information answering the below. Please label it clearly and have your responses follow the i.-vii. as listed below.

Clarification required:

§15.715(f), §15.713(l), §15.711(j) Security

The device operations procedures must include documentation with a detailed explanation of the following for each database the device is expected to work with:

- i. What communication protocol is used between the database and the WSD?
- ii. How are communications initiated?
- iii. How does the WSD validate messages from the database?
- iv. How does the device handle failure to communicate or authenticate the database?
- v. How does the database validate messages from a WSD?
- vi. What encryption method is used?
- vii. How does the database ensure secure registration of protected devices?

Answer :

See Attachment -1 to this document:

2. Please provide Declaration or GUI screenshot for the below:

Clarification required:

§15.711(i) Push notification to Fixed and Mode II

Confirm that the WSD device changes channels (or cease operation) when it receives 'push' notification from the database.

Using system management software, register the device at (specific coordinates) and wait for the database to send a push notification. Confirm that, once the notification is received, the device responds to the new channel availability list provided by the database, which would include ceasing operation on a channel no longer available, or ceases operation.

Answer :

The WSD response to Push notification is depicted in the Test Report paragraph 4.1 " Successful Registration 15.713 (g)(3)"

3. Please provide Declaration for the below:

**Clarification required:**

§ 15.711(b) Location accuracy

For Fixed and Mode II devices, provide details regarding the technologies used by the device to determine its location and how, in case of other than GPS technology, the location uncertainty is calculated with a 95% confidence level.

**Answer :**

The technologies used to determine the WSD location accuracy of 95% are depicted in the WSD Operation Manual paragraph 2.2.2

**4. Please provide Declaration or WSD GUI screenshot for the below**

**Clarification required:**

§ 15.712 Interference protection requirement (Fixed and personal/portable)

Using system management software or database, provide different location (coordinates) so that compliance with operating channel and power level is shown under each of the scenarios outlined in § 15.712. Include a sample scan showing the total channel power and adjacent channel emission settings for test coordinates.

**Answer :**

The fact that the WSD operates at the channel allocated by the Data Base in a specific location is depicted in the Test Report paragraph 4.1 " Successful Registration 15.713 (g)(3)"

The emission sample scans are depicted in the Test Report paragraph 6- "Adjacent Channel" and 7- "Maximum Transmitted Peak Power Output"

**5. Please provide WSD GUI screenshot or Declaration for the below:**

**Clarification required:**

§ 15.711(c)(2)(ii), (d)(3), § 15.715(e) Fixed and Mode II Power level reduction

Using system management software, make a channel availability request to the database. Using the spectrum analyzer, confirm that the WSD operates at no more than the maximum power level indicated by the database and that the power level cannot be set to a higher level than indicated by the database at that specific location. If the device cannot reduce power, it must cease operation.

**Answer :**

The Spectrum Bridge Data Base ( and other Data Bases as well) do not support the power level response, therefore the Channels allocated to the WSD by the Data Base are assuming a 30dBm output power level



Best Regards,

**Israel Koffman**

CEO

**Runcom Ltd.**

Direct Phone: +972-3-9428874

Office Phone: +972-3-9428888

Mobile Phone: +972-545-303110

USA Mobile Phone: 1-646-530-1502

Skype: Israel.Koffman

Additional email: [israel\\_k@netvision.net.il](mailto:israel_k@netvision.net.il)

FAX: +972-3-9528805

Websites: [www.runcom.com](http://www.runcom.com) and [http://rf-mw.org/multiple\\_access\\_method\\_ofdma.html](http://rf-mw.org/multiple_access_method_ofdma.html)