

Test Plot 1#: RDR4320V_PTT_FM 12.5kHz_Face Up_136.0125 MHz**DUT: Digital Two-Way Radio; Type: RDR4320V; Serial: 18030800422**

Communication System: FM; Frequency: 136.012 MHz; Duty Cycle: 1:1

Medium parameters used: $f = 136.012$ MHz; $\sigma = 0.78$ S/m; $\epsilon_r = 52.147$; $\rho = 1000$ kg/m³

Phantom section: Flat Section

DASY5 Configuration:

- Probe: EX3DV4 - SN7329; ConvF(12.88, 12.88, 12.88); Calibrated: 2018/1/22;
- Sensor-Surface: 1.4mm (Mechanical Surface Detection)
- Electronics: DAE4 Sn1459; Calibrated: 2017/9/15
- Phantom: ELI v8.0; Type: QDOVA004AA; Serial: 2051
- Measurement SW: DASY52, Version 52.8 (8);

Area Scan (71x151x1): Interpolated grid: dx=1.500 mm, dy=1.500 mm

Maximum value of SAR (interpolated) = 4.70 W/kg

Zoom Scan (5x5x7)/Cube 0: Measurement grid: dx=8mm, dy=8mm, dz=5mm

Reference Value = 66.23 V/m; Power Drift = -0.07 dB

Peak SAR (extrapolated) = 6.22 W/kg

SAR(1 g) = 3.24 W/kg; SAR(10 g) = 2.48 W/kg

Maximum value of SAR (measured) = 4.65 W/kg

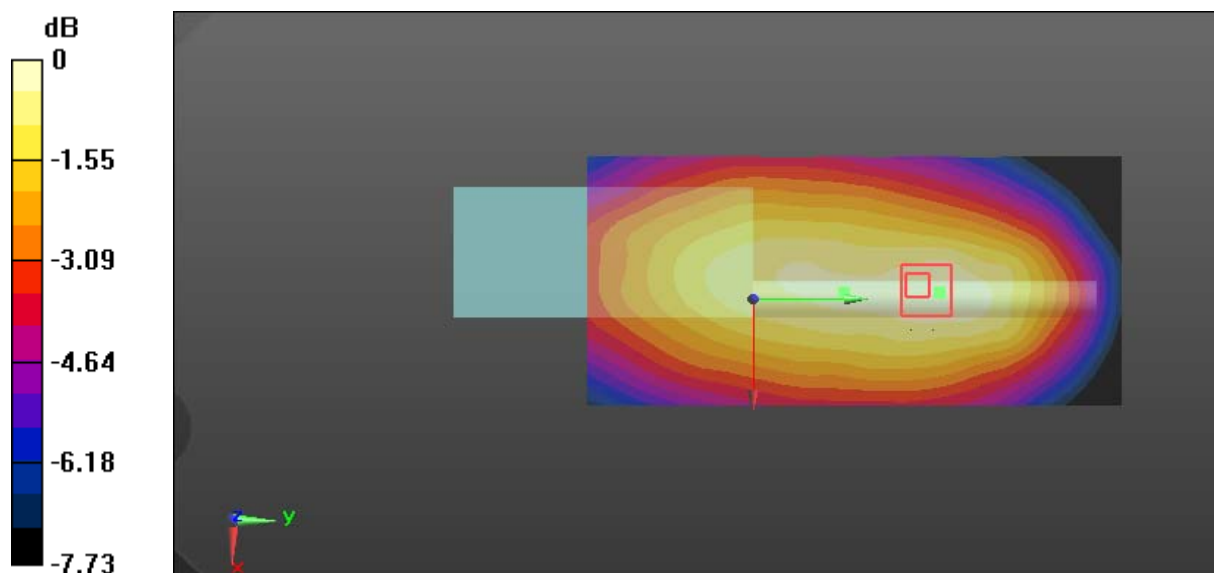

0 dB = 4.65 W/kg = 6.67 dBW/kg

Test Plot 2#: RDR4320V_PTT_FM 12.5kHz_Face Up_147.0125 MHz**DUT: Digital Two-Way Radio; Type: RDR4320V; Serial: 18030800422**

Communication System: FM; Frequency: 147.012 MHz; Duty Cycle: 1:1

Medium parameters used: $f = 147.012$ MHz; $\sigma = 0.779$ S/m; $\epsilon_r = 51.501$; $\rho = 1000$ kg/m³

Phantom section: Flat Section

DASY5 Configuration:

- Probe: EX3DV4 - SN7329; ConvF(12.88, 12.88, 12.88); Calibrated: 2018/1/22;
- Sensor-Surface: 1.4mm (Mechanical Surface Detection)
- Electronics: DAE4 Sn1459; Calibrated: 2017/9/15
- Phantom: ELI v8.0; Type: QDOVA004AA; Serial: 2051
- Measurement SW: DASY52, Version 52.8 (8);

Area Scan (71x151x1): Interpolated grid: dx=1.500 mm, dy=1.500 mm

Maximum value of SAR (interpolated) = 2.11 W/kg

Zoom Scan (6x6x7)/Cube 0: Measurement grid: dx=8mm, dy=8mm, dz=5mm

Reference Value = 43.87 V/m; Power Drift = -0.06 dB

Peak SAR (extrapolated) = 2.49 W/kg

SAR(1 g) = 1.76 W/kg; SAR(10 g) = 1.32 W/kg

Maximum value of SAR (measured) = 2.14 W/kg

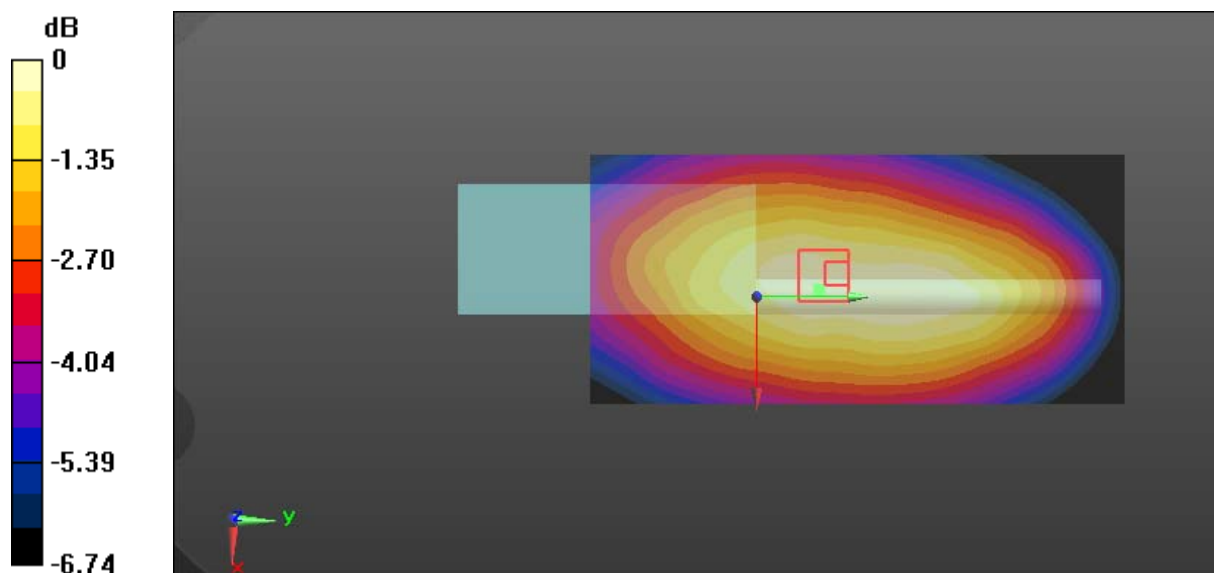

0 dB = 2.14 W/kg = 3.30 dBW/kg

Test Plot 3#: RDR4320V_PTT_FM 12.5kHz_Face Up_160.0125 MHz**DUT: Digital Two-Way Radio; Type: RDR4320V; Serial: 18030800422**

Communication System: FM; Frequency: 160.012 MHz; Duty Cycle: 1:1

Medium parameters used: $f = 160.012$ MHz; $\sigma = 0.767$ S/m; $\epsilon_r = 51.013$; $\rho = 1000$ kg/m³

Phantom section: Flat Section

DASY5 Configuration:

- Probe: EX3DV4 - SN7329; ConvF(12.88, 12.88, 12.88); Calibrated: 2018/1/22;
- Sensor-Surface: 1.4mm (Mechanical Surface Detection)
- Electronics: DAE4 Sn1459; Calibrated: 2017/9/15
- Phantom: ELI v8.0; Type: QDOVA004AA; Serial: 2051
- Measurement SW: DASY52, Version 52.8 (8);

Area Scan (71x151x1): Interpolated grid: dx=1.500 mm, dy=1.500 mm

Maximum value of SAR (interpolated) = 2.14 W/kg

Zoom Scan (5x7x7)/Cube 0: Measurement grid: dx=8mm, dy=8mm, dz=5mm

Reference Value = 45.66 V/m; Power Drift = -0.15 dB

Peak SAR (extrapolated) = 2.31 W/kg

SAR(1 g) = 1.62 W/kg; SAR(10 g) = 1.30 W/kg

Maximum value of SAR (measured) = 2.00 W/kg

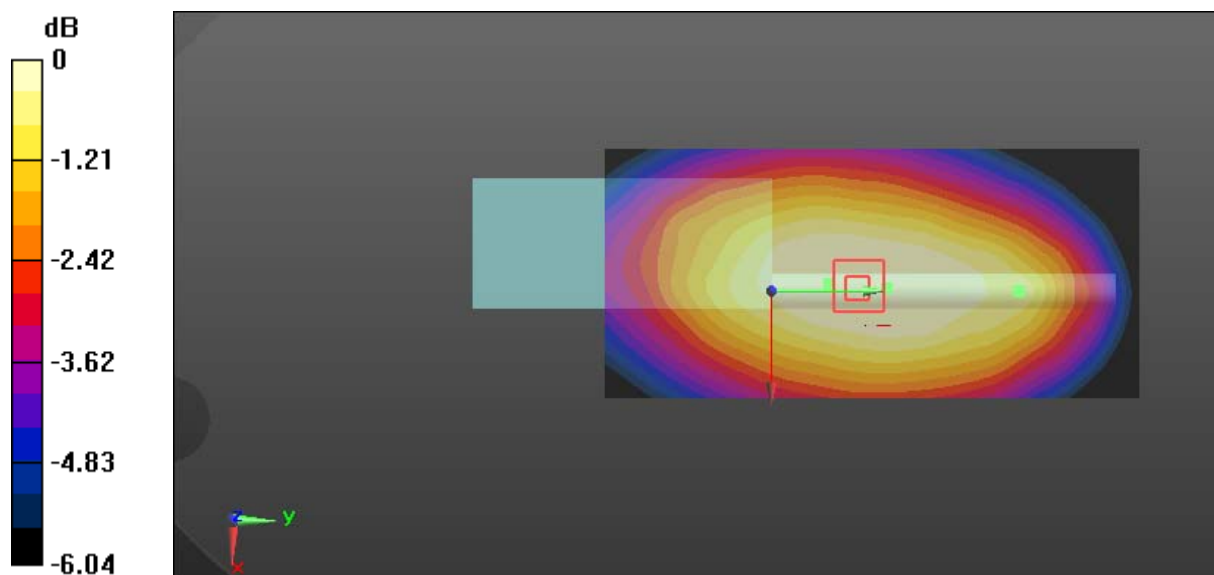

0 dB = 2.00 W/kg = 3.01 dBW/kg

Test Plot 4#: RDR4320V_PTT_4FSK 12.5kHz_Face Up_136.0125 MHz

DUT: Digital Two-Way Radio; Type: RDR4320V; Serial: 18030800422

Communication System: 4FSK; Frequency: 136.012 MHz; Duty Cycle: 1:2

Medium parameters used: $f = 136.012$ MHz; $\sigma = 0.78$ S/m; $\epsilon_r = 52.147$; $\rho = 1000$ kg/m³

Phantom section: Flat Section

DASY5 Configuration:

- Probe: EX3DV4 - SN7329; ConvF(12.88, 12.88, 12.88); Calibrated: 2018/1/22;
- Sensor-Surface: 1.4mm (Mechanical Surface Detection)
- Electronics: DAE4 Sn1459; Calibrated: 2017/9/15
- Phantom: ELI v8.0; Type: QDOVA004AA; Serial: 2051
- Measurement SW: DASY52, Version 52.8 (8);

Area Scan (71x151x1): Interpolated grid: dx=1.500 mm, dy=1.500 mm

Maximum value of SAR (interpolated) = 2.13 W/kg

Zoom Scan (5x5x7)/Cube 0: Measurement grid: dx=8mm, dy=8mm, dz=5mm

Reference Value = 38.26 V/m; Power Drift = -0.02 dB

Peak SAR (extrapolated) = 2.88 W/kg

SAR(1 g) = 1.41 W/kg; SAR(10 g) = 0.998 W/kg

Maximum value of SAR (measured) = 2.16 W/kg

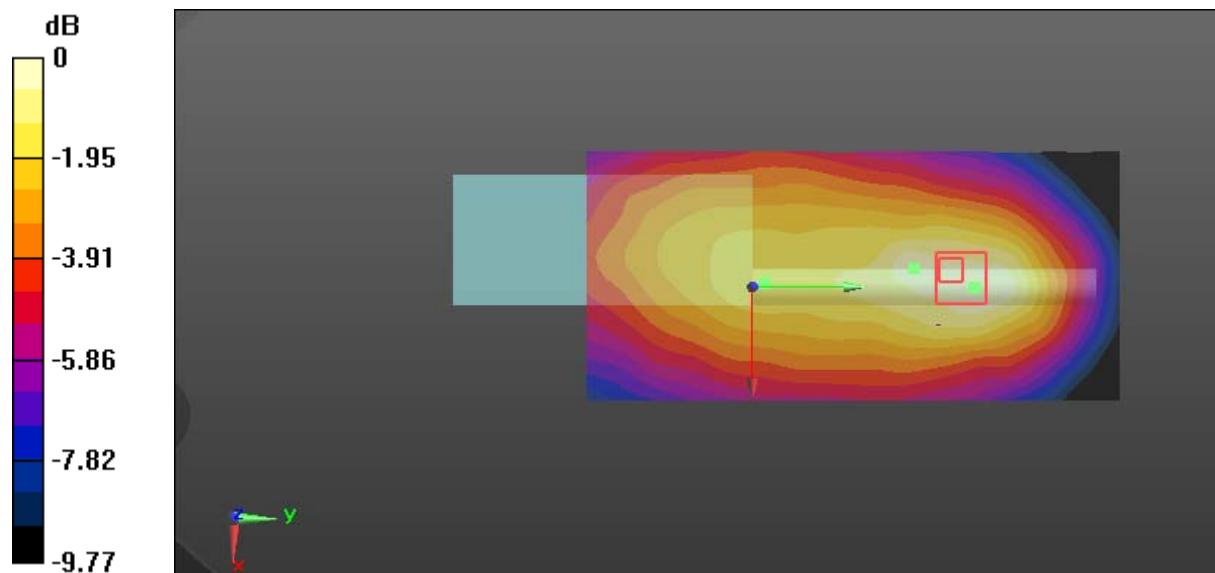

0 dB = 2.16 W/kg = 3.34 dBW/kg

Test Plot 5#: RDR4320V_PTT_4FSK 12.5kHz_Face Up_147.0125 MHz**DUT: Digital Two-Way Radio; Type: RDR4320V; Serial: 18030800422**

Communication System: 4FSK; Frequency: 147.012 MHz; Duty Cycle: 1:2

Medium parameters used: $f = 147.012$ MHz; $\sigma = 0.779$ S/m; $\epsilon_r = 51.501$; $\rho = 1000$ kg/m³

Phantom section: Flat Section

DASY5 Configuration:

- Probe: EX3DV4 - SN7329; ConvF(12.88, 12.88, 12.88); Calibrated: 2018/1/22;
- Sensor-Surface: 1.4mm (Mechanical Surface Detection)
- Electronics: DAE4 Sn1459; Calibrated: 2017/9/15
- Phantom: ELI v8.0; Type: QDOVA004AA; Serial: 2051
- Measurement SW: DASY52, Version 52.8 (8);

Area Scan (71x151x1): Interpolated grid: dx=1.500 mm, dy=1.500 mm

Maximum value of SAR (interpolated) = 1.05 W/kg

Zoom Scan (5x5x7)/Cube 0: Measurement grid: dx=8mm, dy=8mm, dz=5mm

Reference Value = 32.18 V/m; Power Drift = -0.04 dB

Peak SAR (extrapolated) = 1.27 W/kg

SAR(1 g) = 0.870 W/kg; SAR(10 g) = 0.693 W/kg

Maximum value of SAR (measured) = 1.11 W/kg

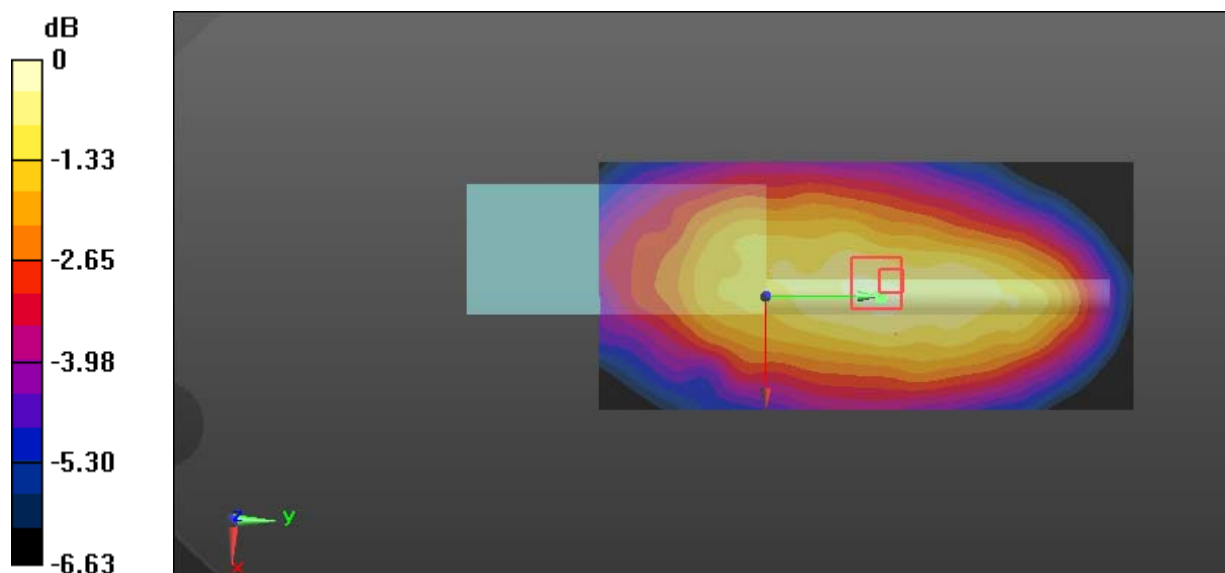

0 dB = 1.11 W/kg = 0.45 dBW/kg

Test Plot 6#: RDR4320V_PTT_4FSK 12.5kHz_Face Up_160.0125 MHz**DUT: Digital Two-Way Radio; Type: RDR4320V; Serial: 18030800422**

Communication System: 4FSK; Frequency: 160.012 MHz; Duty Cycle: 1:2

Medium parameters used: $f = 160.012$ MHz; $\sigma = 0.767$ S/m; $\epsilon_r = 51.013$; $\rho = 1000$ kg/m³

Phantom section: Flat Section

DASY5 Configuration:

- Probe: EX3DV4 - SN7329; ConvF(12.88, 12.88, 12.88); Calibrated: 2018/1/22;
- Sensor-Surface: 1.4mm (Mechanical Surface Detection)
- Electronics: DAE4 Sn1459; Calibrated: 2017/9/15
- Phantom: ELI v8.0; Type: QDOVA004AA; Serial: 2051
- Measurement SW: DASY52, Version 52.8 (8);

Area Scan (71x151x1): Interpolated grid: dx=1.500 mm, dy=1.500 mm

Maximum value of SAR (interpolated) = 1.11 W/kg

Zoom Scan (6x12x7)/Cube 0: Measurement grid: dx=8mm, dy=8mm, dz=5mm

Reference Value = 30.76 V/m; Power Drift = -0.05 dB

Peak SAR (extrapolated) = 1.23 W/kg

SAR(1 g) = 0.819 W/kg; SAR(10 g) = 0.649 W/kg

Maximum value of SAR (measured) = 1.06 W/kg

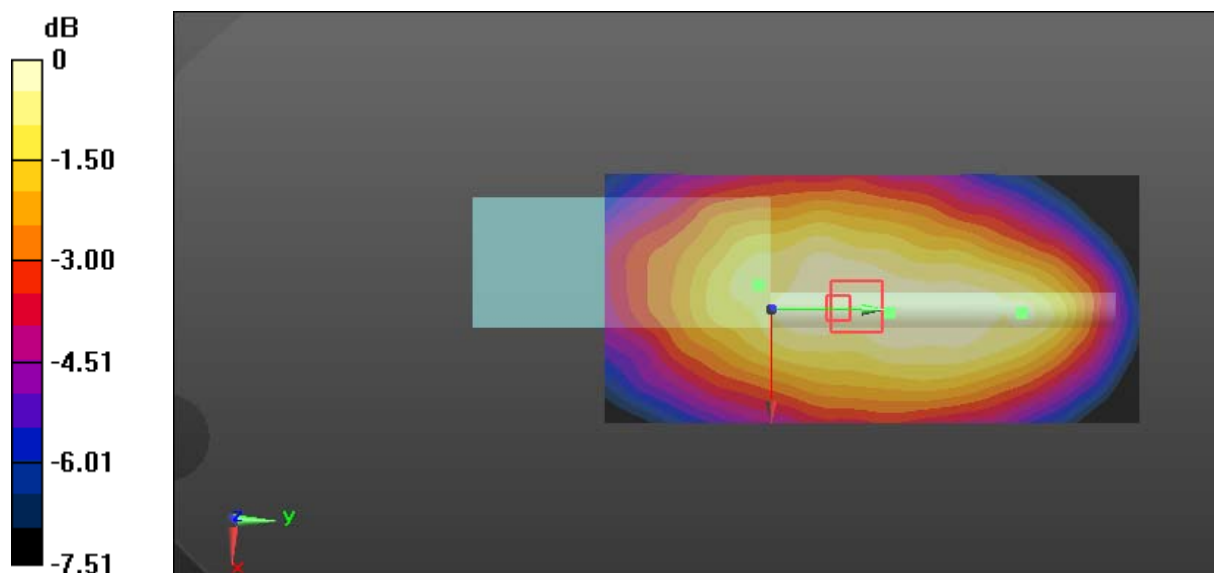

0 dB = 1.06 W/kg = 0.25 dBW/kg

Test Plot 7#: RDR4320V_PTT_FM 12.5kHz_Body Back_136.0125 MHz**DUT: Digital Two-Way Radio; Type: RDR4320V; Serial: 18030800422**

Communication System: FM; Frequency: 136.012 MHz; Duty Cycle: 1:1

Medium parameters used: $f = 136.012$ MHz; $\sigma = 0.792$ S/m; $\epsilon_r = 62.278$; $\rho = 1000$ kg/m³

Phantom section: Flat Section

DASY5 Configuration:

- Probe: EX3DV4 - SN7329; ConvF(12.56, 12.56, 12.56); Calibrated: 2018/1/22;
- Sensor-Surface: 1.4mm (Mechanical Surface Detection)
- Electronics: DAE4 Sn1459; Calibrated: 2017/9/15
- Phantom: ELI v8.0; Type: QDOVA004AA; Serial: 2051
- Measurement SW: DASY52, Version 52.8 (8);

Area Scan (71x151x1): Interpolated grid: dx=1.500 mm, dy=1.500 mm

Maximum value of SAR (interpolated) = 15.7 W/kg

Zoom Scan (5x5x7)/Cube 0: Measurement grid: dx=8mm, dy=8mm, dz=5mm

Reference Value = 71.16 V/m; Power Drift = -0.15 dB

Peak SAR (extrapolated) = 39.8 W/kg

SAR(1 g) = 9.8 W/kg; SAR(10 g) = 4.79 W/kg

Maximum value of SAR (measured) = 21.2 W/kg

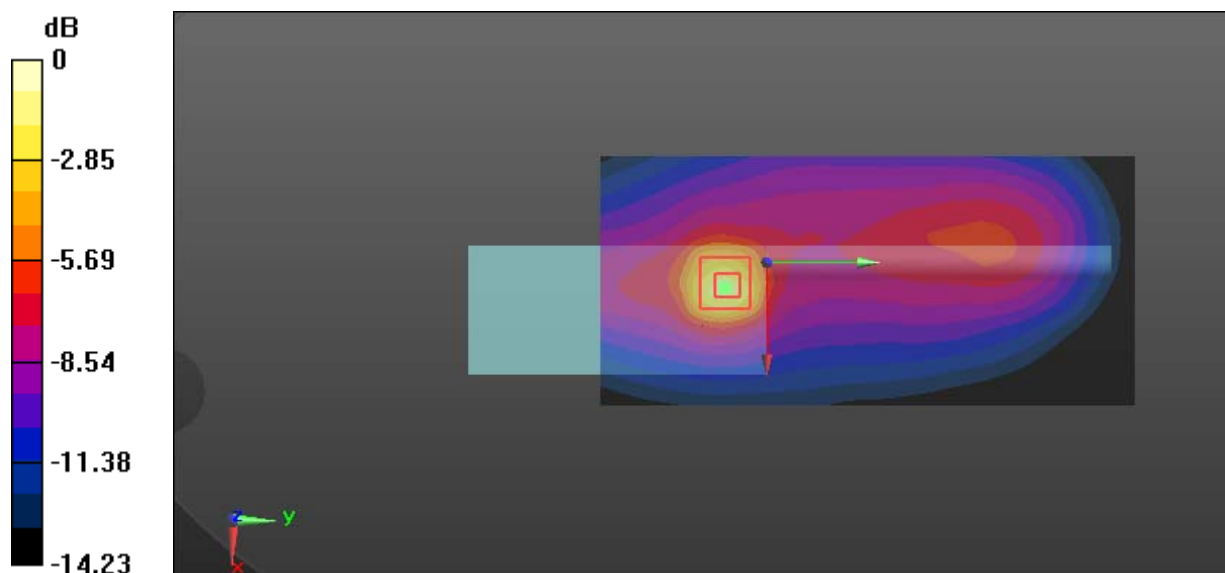

0 dB = 21.2 W/kg = 13.26 dBW/kg

Test Plot 8#: RDR4320V_PTT_FM 12.5kHz_Body Back_141 MHz**DUT: Digital Two-Way Radio; Type: RDR4320V; Serial: 18030800422**

Communication System: FM; Frequency: 141 MHz; Duty Cycle: 1:1

Medium parameters used: $f = 141$ MHz; $\sigma = 0.787$ S/m; $\epsilon_r = 61.886$; $\rho = 1000$ kg/m³

Phantom section: Flat Section

DASY5 Configuration:

- Probe: EX3DV4 - SN7329; ConvF(12.56, 12.56, 12.56); Calibrated: 2018/1/22;
- Sensor-Surface: 1.4mm (Mechanical Surface Detection)
- Electronics: DAE4 Sn1459; Calibrated: 2017/9/15
- Phantom: ELI v8.0; Type: QDOVA004AA; Serial: 2051
- Measurement SW: DASY52, Version 52.8 (8);

Area Scan (71x151x1): Interpolated grid: dx=1.500 mm, dy=1.500 mm

Maximum value of SAR (interpolated) = 12.1 W/kg

Zoom Scan (5x5x7)/Cube 0: Measurement grid: dx=8mm, dy=8mm, dz=5mm

Reference Value = 57.86 V/m; Power Drift = 0.09 dB

Peak SAR (extrapolated) = 26.2 W/kg

SAR(1 g) = 6.96 W/kg; SAR(10 g) = 3.55 W/kg

Maximum value of SAR (measured) = 14.1 W/kg

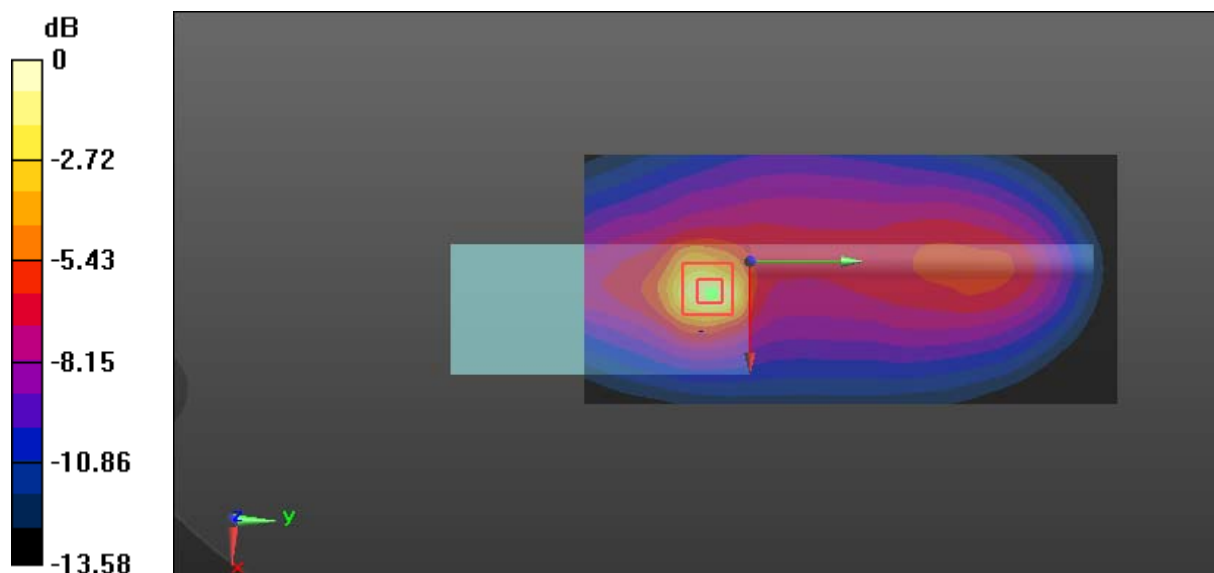

0 dB = 14.1 W/kg = 11.49 dBW/kg

Test Plot 9#: RDR4320V_PTT_FM 12.5kHz_Body Back_146.9875 MHz**DUT: Digital Two-Way Radio; Type: RDR4320V; Serial: 18030800422**

Communication System: FM; Frequency: 146.988 MHz; Duty Cycle: 1:1

Medium parameters used: $f = 146.988$ MHz; $\sigma = 0.812$ S/m; $\epsilon_r = 61.604$; $\rho = 1000$ kg/m³

Phantom section: Flat Section

DASY5 Configuration:

- Probe: EX3DV4 - SN7329; ConvF(12.56, 12.56, 12.56); Calibrated: 2018/1/22;
- Sensor-Surface: 1.4mm (Mechanical Surface Detection)
- Electronics: DAE4 Sn1459; Calibrated: 2017/9/15
- Phantom: ELI v8.0; Type: QDOVA004AA; Serial: 2051
- Measurement SW: DASY52, Version 52.8 (8);

Area Scan (71x151x1): Interpolated grid: dx=1.500 mm, dy=1.500 mm

Maximum value of SAR (interpolated) = 7.78 W/kg

Zoom Scan (5x5x7)/Cube 0: Measurement grid: dx=8mm, dy=8mm, dz=5mm

Reference Value = 43.05 V/m; Power Drift = -0.09 dB

Peak SAR (extrapolated) = 15.2 W/kg

SAR(1 g) = 4.04 W/kg; SAR(10 g) = 2.05 W/kg

Maximum value of SAR (measured) = 8.06 W/kg

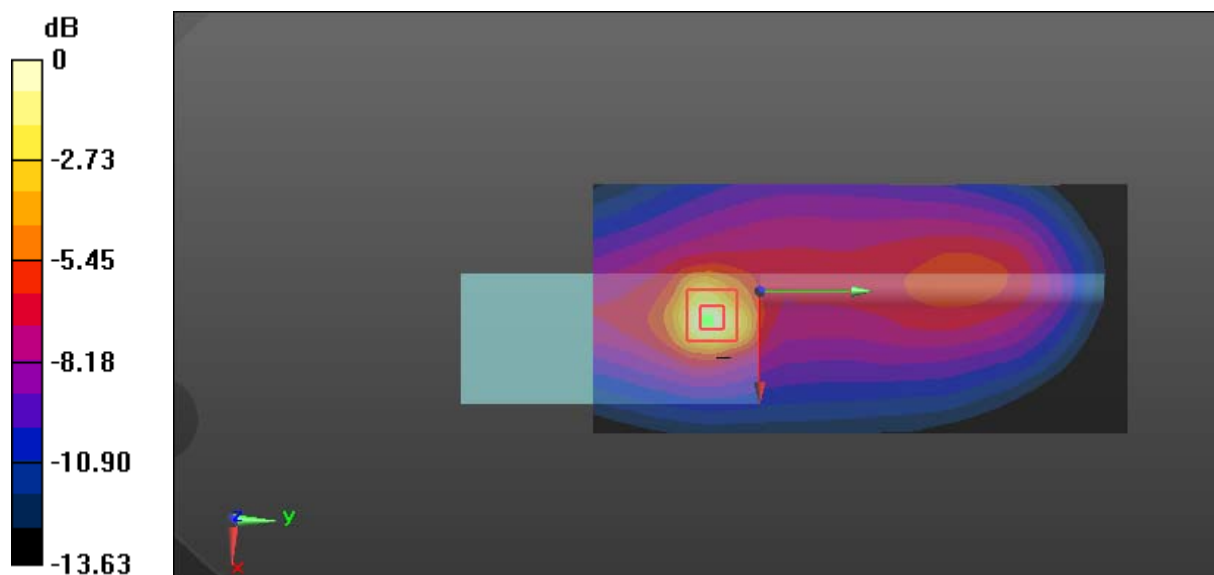

0 dB = 8.06 W/kg = 9.06 dBW/kg

Test Plot 10#: RDR4320V_PTT_FM 12.5kHz_Body Back_147.0125 MHz**DUT: Digital Two-Way Radio; Type: RDR4320V; Serial: 18030800422**

Communication System: FM; Frequency: 147.012 MHz; Duty Cycle: 1:1

Medium parameters used: $f = 147.012$ MHz; $\sigma = 0.809$ S/m; $\epsilon_r = 61.605$; $\rho = 1000$ kg/m³

Phantom section: Flat Section

DASY5 Configuration:

- Probe: EX3DV4 - SN7329; ConvF(12.56, 12.56, 12.56); Calibrated: 2018/1/22;
- Sensor-Surface: 1.4mm (Mechanical Surface Detection)
- Electronics: DAE4 Sn1459; Calibrated: 2017/9/15
- Phantom: ELI v8.0; Type: QDOVA004AA; Serial: 2051
- Measurement SW: DASY52, Version 52.8 (8);

Area Scan (71x151x1): Interpolated grid: dx=1.500 mm, dy=1.500 mm

Maximum value of SAR (interpolated) = 9.47 W/kg

Zoom Scan (5x5x7)/Cube 0: Measurement grid: dx=8mm, dy=8mm, dz=5mm

Reference Value = 48.49 V/m; Power Drift = 0.05 dB

Peak SAR (extrapolated) = 17.2 W/kg

SAR(1 g) = 5.4 W/kg; SAR(10 g) = 2.75 W/kg

Maximum value of SAR (measured) = 10.00 W/kg

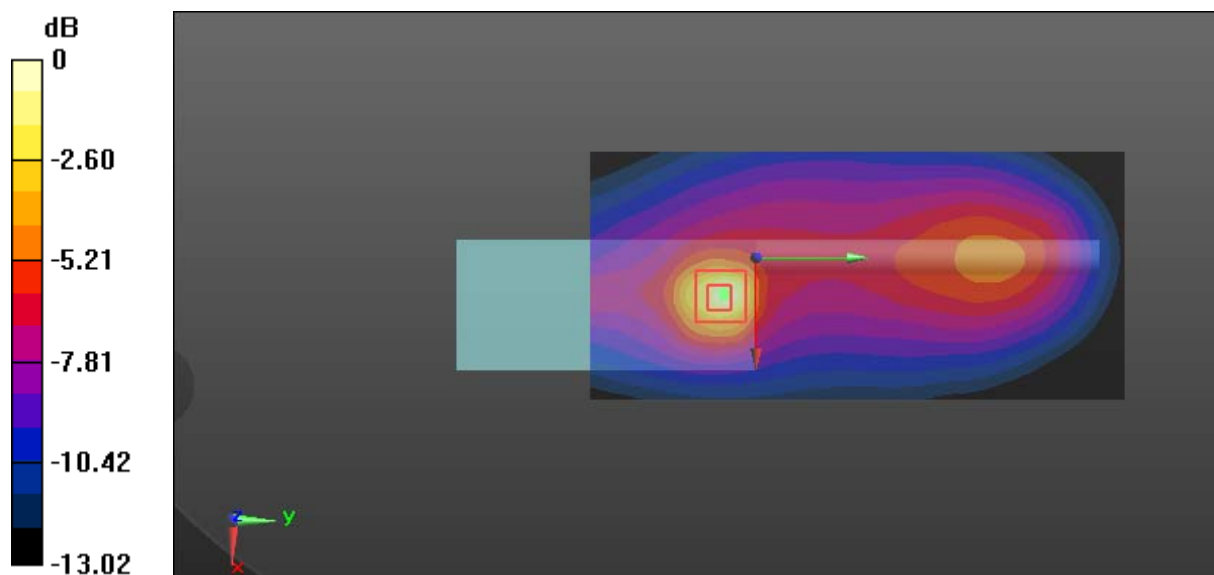

0 dB = 10.00 W/kg = 10.00 dBW/kg

Test Plot 11#: RDR4320V_PTT_FM 12.5kHz_Body Back_160.0125 MHz

DUT: Digital Two-Way Radio; Type: RDR4320V; Serial: 18030800422

Communication System: FM; Frequency: 160.012 MHz; Duty Cycle: 1:1

Medium parameters used: $f = 160.012 \text{ MHz}$; $\sigma = 0.825 \text{ S/m}$; $\epsilon_r = 60.794$; $\rho = 1000 \text{ kg/m}^3$

Phantom section: Flat Section

DASY5 Configuration:

- Probe: EX3DV4 - SN7329; ConvF(12.56, 12.56, 12.56); Calibrated: 2018/1/22;
- Sensor-Surface: 1.4mm (Mechanical Surface Detection)
- Electronics: DAE4 Sn1459; Calibrated: 2017/9/15
- Phantom: ELI v8.0; Type: QDOVA004AA; Serial: 2051
- Measurement SW: DASY52, Version 52.8 (8);

Area Scan (71x151x1): Interpolated grid: $dx=1.500 \text{ mm}$, $dy=1.500 \text{ mm}$

Maximum value of SAR (interpolated) = 4.60 W/kg

Zoom Scan (5x5x7)/Cube 0: Measurement grid: $dx=8\text{mm}$, $dy=8\text{mm}$, $dz=5\text{mm}$

Reference Value = 38.75 V/m; Power Drift = -0.13 dB

Peak SAR (extrapolated) = 8.82 W/kg

SAR(1 g) = 2.6 W/kg; SAR(10 g) = 1.38 W/kg

Maximum value of SAR (measured) = 4.81 W/kg

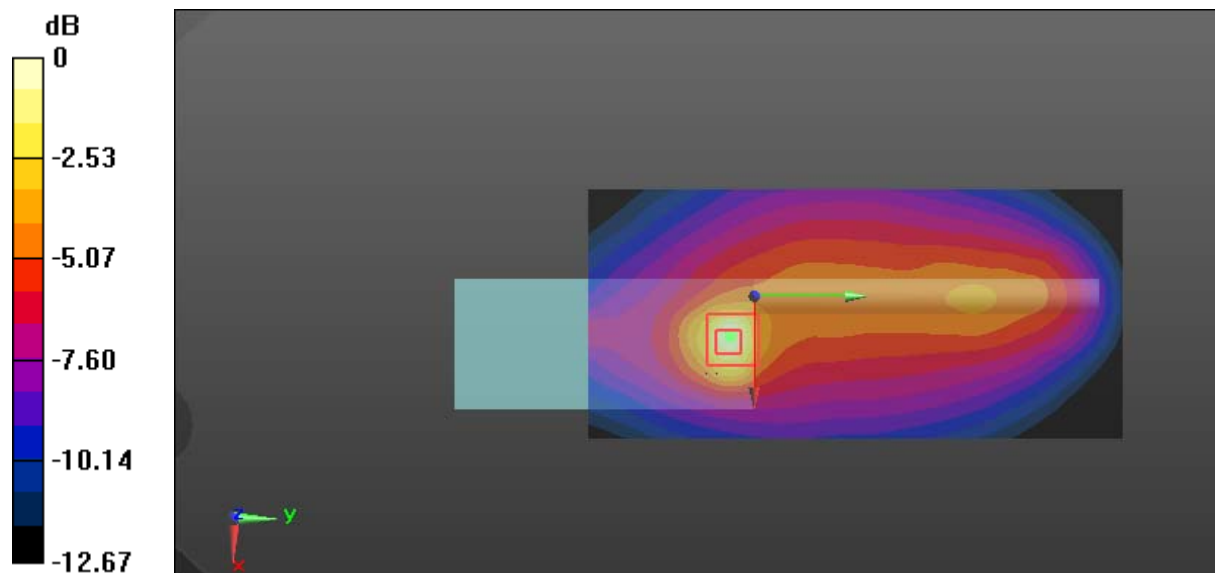

0 dB = 4.81 W/kg = 6.82 dBW/kg

Test Plot 12#: RDR4320V_PTT_4FSK 12.5kHz_Body Back_136.0125 MHz**DUT: Digital Two-Way Radio; Type: RDR4320V; Serial: 18030800422**

Communication System: 4FSK; Frequency: 136.012 MHz; Duty Cycle: 1:2

Medium parameters used: $f = 136.012$ MHz; $\sigma = 0.792$ S/m; $\epsilon_r = 62.278$; $\rho = 1000$ kg/m³

Phantom section: Flat Section

DASY5 Configuration:

- Probe: EX3DV4 - SN7329; ConvF(12.56, 12.56, 12.56); Calibrated: 2018/1/22;
- Sensor-Surface: 1.4mm (Mechanical Surface Detection)
- Electronics: DAE4 Sn1459; Calibrated: 2017/9/15
- Phantom: ELI v8.0; Type: QDOVA004AA; Serial: 2051
- Measurement SW: DASY52, Version 52.8 (8);

Area Scan (71x151x1): Interpolated grid: dx=1.500 mm, dy=1.500 mm

Maximum value of SAR (interpolated) = 11.8 W/kg

Zoom Scan (5x5x7)/Cube 0: Measurement grid: dx=8mm, dy=8mm, dz=5mm

Reference Value = 50.78 V/m; Power Drift = -0.19 dB

Peak SAR (extrapolated) = 25.3 W/kg

SAR(1 g) = 5.9 W/kg; SAR(10 g) = 2.81 W/kg

Maximum value of SAR (measured) = 12.5 W/kg

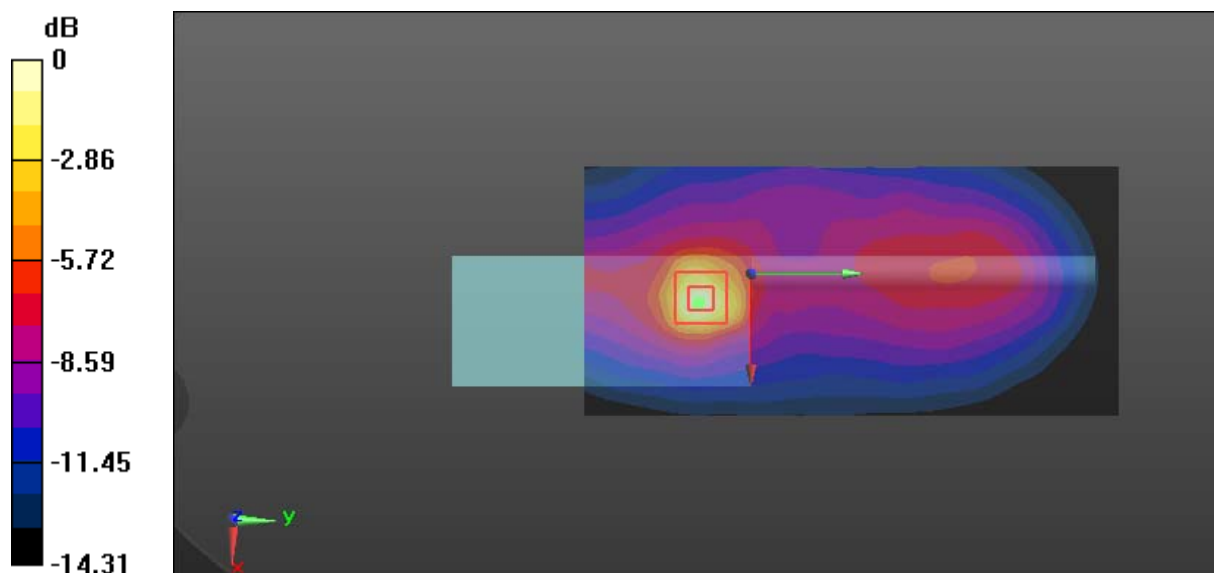

0 dB = 12.5 W/kg = 10.97 dBW/kg

Test Plot 13#: RDR4320V_PTT_4FSK 12.5kHz_Body Back_147.0125 MHz**DUT: Digital Two-Way Radio; Type: RDR4320V; Serial: 18030800422**

Communication System: 4FSK; Frequency: 147.012 MHz; Duty Cycle: 1:2

Medium parameters used: $f = 147.012$ MHz; $\sigma = 0.809$ S/m; $\epsilon_r = 61.605$; $\rho = 1000$ kg/m³

Phantom section: Flat Section

DASY5 Configuration:

- Probe: EX3DV4 - SN7329; ConvF(12.56, 12.56, 12.56); Calibrated: 2018/1/22;
- Sensor-Surface: 1.4mm (Mechanical Surface Detection)
- Electronics: DAE4 Sn1459; Calibrated: 2017/9/15
- Phantom: ELI v8.0; Type: QDOVA004AA; Serial: 2051
- Measurement SW: DASY52, Version 52.8 (8);

Area Scan (71x151x1): Interpolated grid: dx=1.500 mm, dy=1.500 mm

Maximum value of SAR (interpolated) = 4.88 W/kg

Zoom Scan (5x5x7)/Cube 0: Measurement grid: dx=8mm, dy=8mm, dz=5mm

Reference Value = 31.70 V/m; Power Drift = -0.01 dB

Peak SAR (extrapolated) = 14.2 W/kg

SAR(1 g) = 3.05 W/kg; SAR(10 g) = 1.41 W/kg

Maximum value of SAR (measured) = 6.78 W/kg

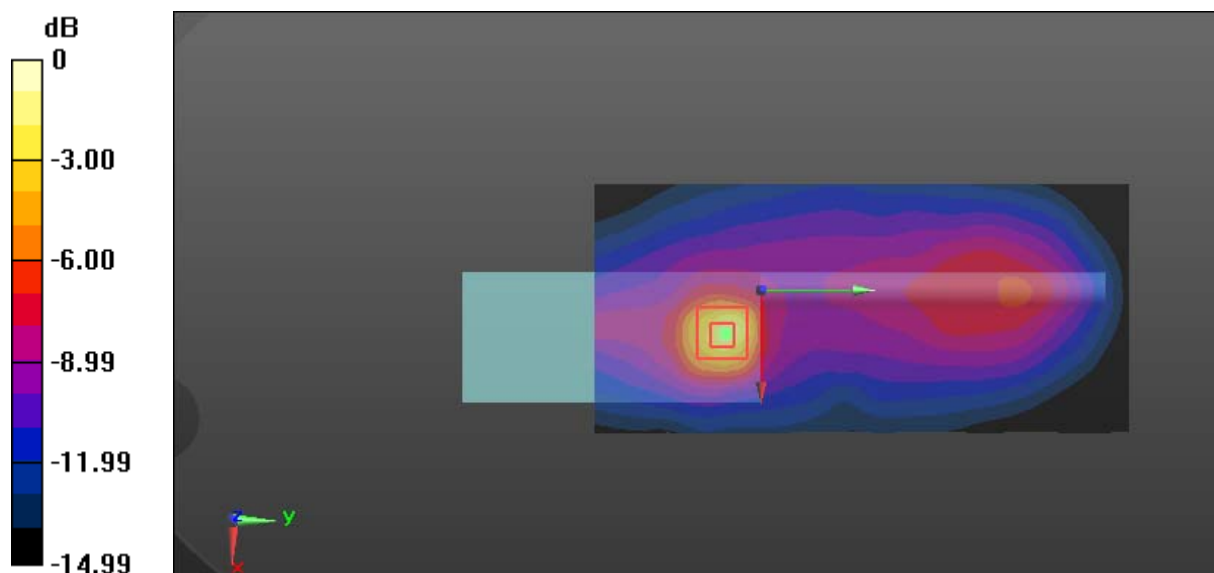

0 dB = 6.78 W/kg = 8.31 dBW/kg

Test Plot 14#: RDR4320V_PTT_4FSK 12.5kHz_Body Back_160.0125 MHz**DUT: Digital Two-Way Radio; Type: RDR4320V; Serial: 18030800422**

Communication System: 4FSK; Frequency: 160.012 MHz; Duty Cycle: 1:2

Medium parameters used: $f = 160.012$ MHz; $\sigma = 0.825$ S/m; $\epsilon_r = 60.794$; $\rho = 1000$ kg/m³

Phantom section: Flat Section

DASY5 Configuration:

- Probe: EX3DV4 - SN7329; ConvF(12.56, 12.56, 12.56); Calibrated: 2018/1/22;
- Sensor-Surface: 1.4mm (Mechanical Surface Detection)
- Electronics: DAE4 Sn1459; Calibrated: 2017/9/15
- Phantom: ELI v8.0; Type: QDOVA004AA; Serial: 2051
- Measurement SW: DASY52, Version 52.8 (8);

Area Scan (71x151x1): Interpolated grid: dx=1.500 mm, dy=1.500 mm

Maximum value of SAR (interpolated) = 1.62 W/kg

Zoom Scan (5x5x7)/Cube 0: Measurement grid: dx=8mm, dy=8mm, dz=5mm

Reference Value = 25.77 V/m; Power Drift = -0.10 dB

Peak SAR (extrapolated) = 3.17 W/kg

SAR(1 g) = 1.06 W/kg; SAR(10 g) = 0.591 W/kg

Maximum value of SAR (measured) = 1.92 W/kg

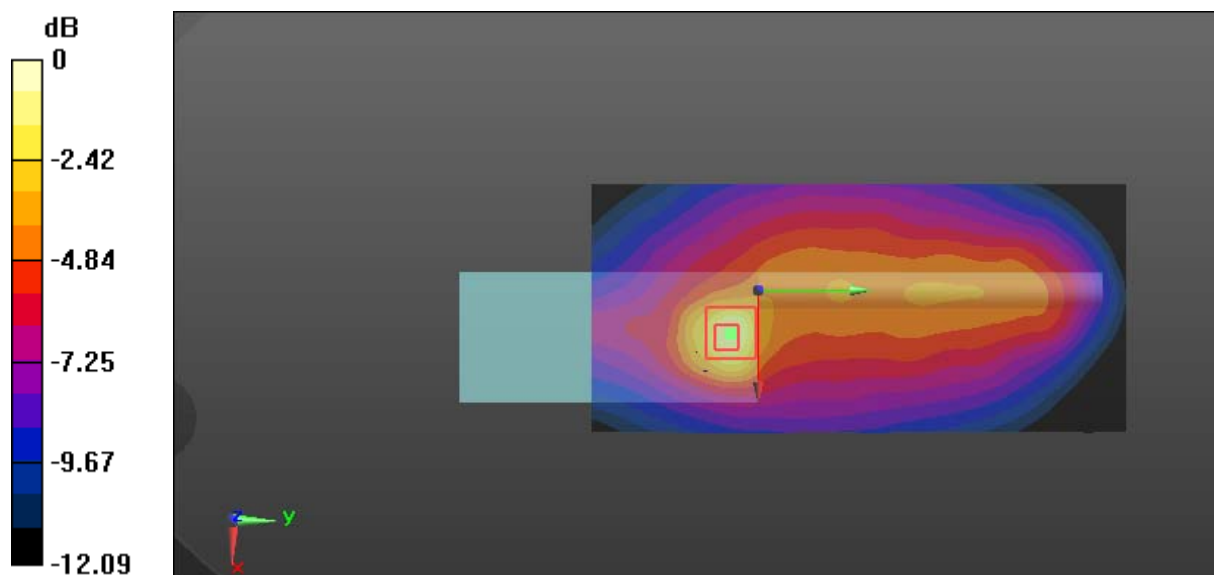

0 dB = 1.92 W/kg = 2.83 dBW/kg

Test Plot 15#: RDR4320V_PTT_FM 12.5kHz_Body Back_136.0125 MHz Headset 1

DUT: Digital Two-Way Radio; Type: RDR4320V; Serial: 18030800422

Communication System: FM; Frequency: 136.012 MHz; Duty Cycle: 1:1

Medium parameters used: $f = 136.012$ MHz; $\sigma = 0.792$ S/m; $\epsilon_r = 62.278$; $\rho = 1000$ kg/m³

Phantom section: Flat Section

DASY5 Configuration:

- Probe: EX3DV4 - SN7329; ConvF(12.56, 12.56, 12.56); Calibrated: 2018/1/22;
- Sensor-Surface: 1.4mm (Mechanical Surface Detection)
- Electronics: DAE4 Sn1459; Calibrated: 2017/9/15
- Phantom: ELI v8.0; Type: QDOVA004AA; Serial: 2051
- Measurement SW: DASY52, Version 52.8 (8);

Area Scan (71x151x1): Interpolated grid: dx=1.500 mm, dy=1.500 mm

Maximum value of SAR (interpolated) = 13.0 W/kg

Zoom Scan (5x5x7)/Cube 0: Measurement grid: dx=8mm, dy=8mm, dz=5mm

Reference Value = 56.81 V/m; Power Drift = -0.11 dB

Peak SAR (extrapolated) = 25.3 W/kg

SAR(1 g) = 6.41 W/kg; SAR(10 g) = 3.14 W/kg

Maximum value of SAR (measured) = 13.3 W/kg

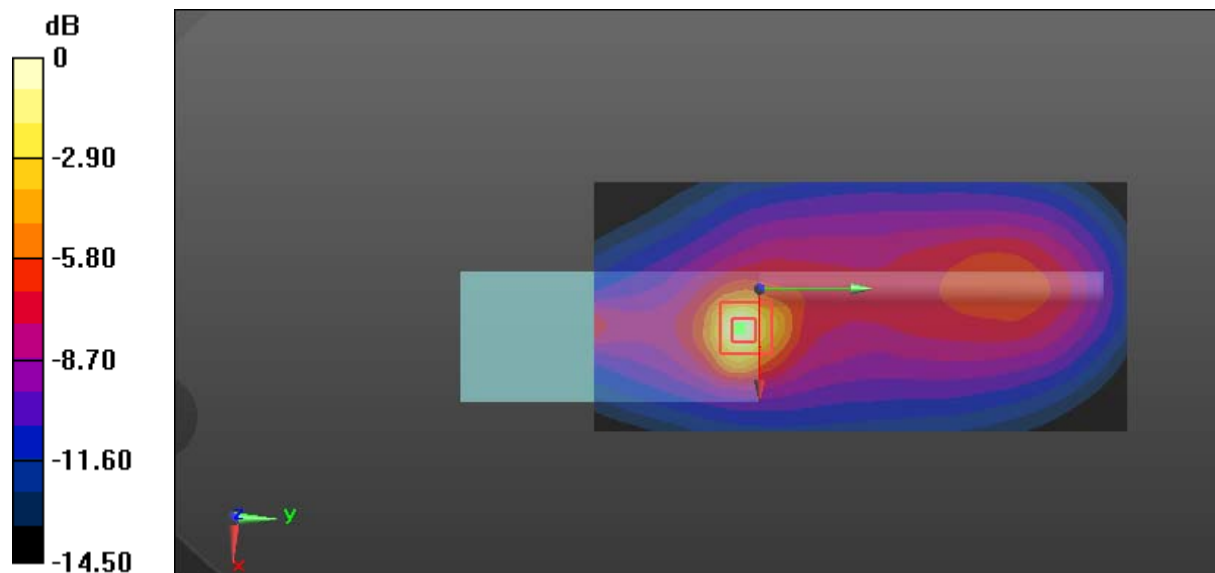

0 dB = 13.3 W/kg = 11.24 dBW/kg

Test Plot 16#: RDR4320V_PTT_FM 12.5kHz_Body Back_136.0125 MHz Headset 2**DUT: Digital Two-Way Radio; Type: RDR4320V; Serial: 18030800422**

Communication System: FM; Frequency: 136.012 MHz; Duty Cycle: 1:1

Medium parameters used: $f = 136.012$ MHz; $\sigma = 0.792$ S/m; $\epsilon_r = 62.278$; $\rho = 1000$ kg/m³

Phantom section: Flat Section

DASY5 Configuration:

- Probe: EX3DV4 - SN7329; ConvF(12.56, 12.56, 12.56); Calibrated: 2018/1/22;
- Sensor-Surface: 1.4mm (Mechanical Surface Detection)
- Electronics: DAE4 Sn1459; Calibrated: 2017/9/15
- Phantom: ELI v8.0; Type: QDOVA004AA; Serial: 2051
- Measurement SW: DASY52, Version 52.8 (8);

Area Scan (71x151x1): Interpolated grid: dx=1.500 mm, dy=1.500 mm

Maximum value of SAR (interpolated) = 11.7 W/kg

Zoom Scan (5x5x7)/Cube 0: Measurement grid: dx=8mm, dy=8mm, dz=5mm

Reference Value = 57.13 V/m; Power Drift = -0.15 dB

Peak SAR (extrapolated) = 23.5 W/kg

SAR(1 g) = 6.12 W/kg; SAR(10 g) = 3.05 W/kg

Maximum value of SAR (measured) = 12.7 W/kg

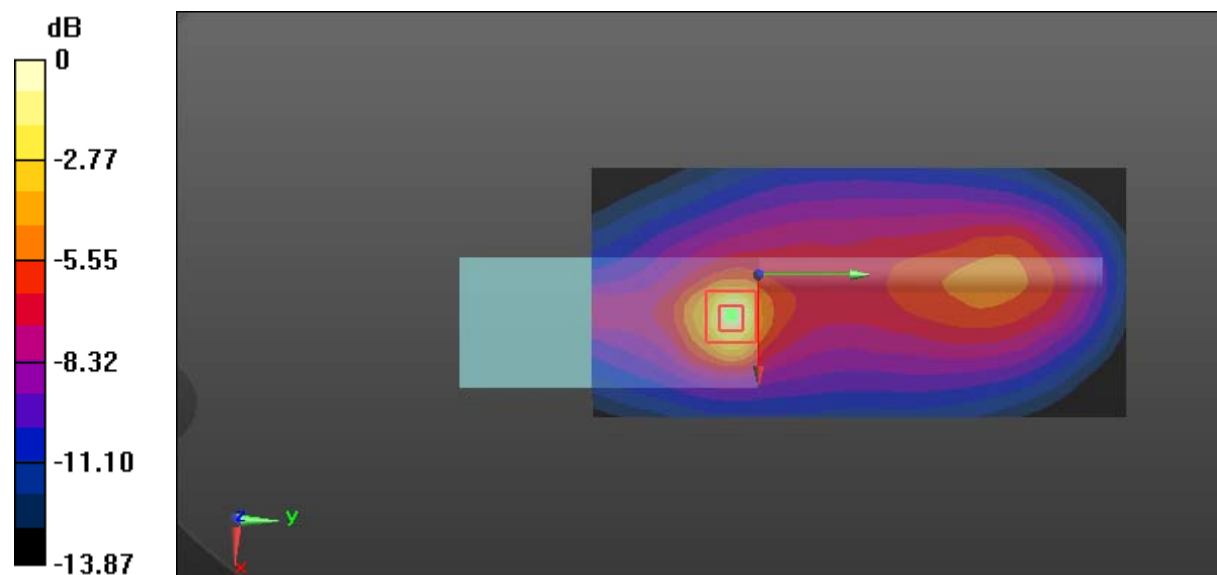

0 dB = 12.7 W/kg = 11.04 dBW/kg

Test Plot 17#: RDR4350V_PTT_FM 12.5kHz_Face Up_136.0125 MHz**DUT: Digital Two-Way Radio; Type: RDR4350V; Serial: 18030800425**

Communication System: FM; Frequency: 136.012 MHz; Duty Cycle: 1:1

Medium parameters used: $f = 136.012$ MHz; $\sigma = 0.78$ S/m; $\epsilon_r = 52.147$; $\rho = 1000$ kg/m³

Phantom section: Flat Section

DASY5 Configuration:

- Probe: EX3DV4 - SN7329; ConvF(12.88, 12.88, 12.88); Calibrated: 2018/1/22;
- Sensor-Surface: 1.4mm (Mechanical Surface Detection)
- Electronics: DAE4 Sn1459; Calibrated: 2017/9/15
- Phantom: ELI v8.0; Type: QDOVA004AA; Serial: 2051
- Measurement SW: DASY52, Version 52.8 (8);

Area Scan (71x151x1): Interpolated grid: dx=1.500 mm, dy=1.500 mm

Maximum value of SAR (interpolated) = 6.80 W/kg

Zoom Scan (5x5x7)/Cube 0: Measurement grid: dx=8mm, dy=8mm, dz=5mm

Reference Value = 66.16 V/m; Power Drift = -0.04 dB

Peak SAR (extrapolated) = 5.85 W/kg

SAR(1 g) = 3.21 W/kg; SAR(10 g) = 2.35 W/kg

Maximum value of SAR (measured) = 4.45 W/kg

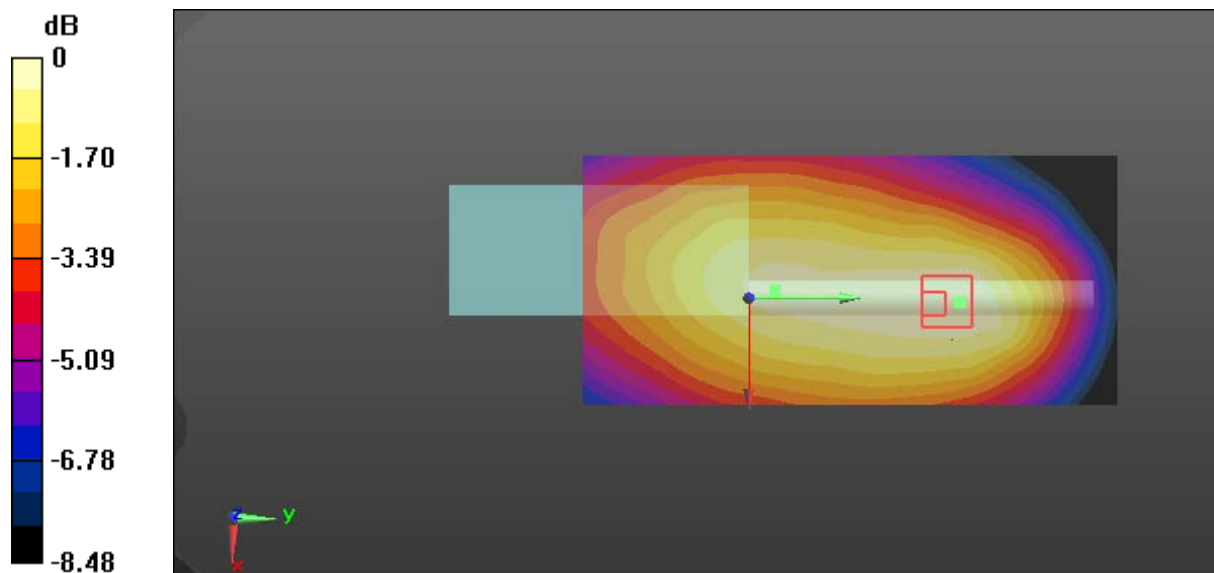

0 dB = 4.45 W/kg = 6.48 dBW/kg

Test Plot 18#: RDR4350V_PTT_FM 12.5kHz_Face Up_147.0125 MHz

DUT: Digital Two-Way Radio; Type: RDR4350V; Serial: 18030800425

Communication System: FM; Frequency: 147.012 MHz; Duty Cycle: 1:1

Medium parameters used: $f = 147.012 \text{ MHz}$; $\sigma = 0.779 \text{ S/m}$; $\epsilon_r = 51.501$; $\rho = 1000 \text{ kg/m}^3$

Phantom section: Flat Section

DASY5 Configuration:

- Probe: EX3DV4 - SN7329; ConvF(12.88, 12.88, 12.88); Calibrated: 2018/1/22;
- Sensor-Surface: 1.4mm (Mechanical Surface Detection)
- Electronics: DAE4 Sn1459; Calibrated: 2017/9/15
- Phantom: ELI v8.0; Type: QDOVA004AA; Serial: 2051
- Measurement SW: DASY52, Version 52.8 (8);

Area Scan (71x151x1): Interpolated grid: $dx=1.500 \text{ mm}$, $dy=1.500 \text{ mm}$

Maximum value of SAR (interpolated) = 2.20 W/kg

Zoom Scan (5x5x7)/Cube 0: Measurement grid: $dx=8\text{mm}$, $dy=8\text{mm}$, $dz=5\text{mm}$

Reference Value = 44.08 V/m; Power Drift = -0.19 dB

Peak SAR (extrapolated) = 2.81 W/kg

SAR(1 g) = 1.66 W/kg; SAR(10 g) = 1.30 W/kg

Maximum value of SAR (measured) = 2.22 W/kg

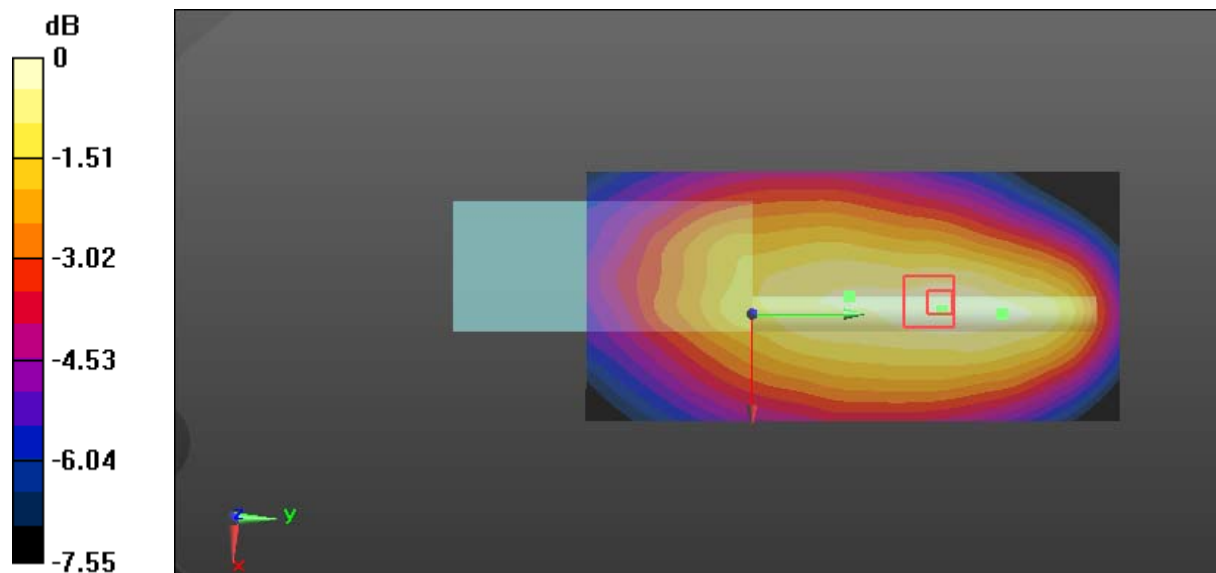

0 dB = 2.22 W/kg = 3.46 dBW/kg

Test Plot 19#: RDR4350V_PTT_FM 12.5kHz_Face Up_160.0125 MHz**DUT: Digital Two-Way Radio; Type: RDR4350V; Serial: 18030800425**

Communication System: FM; Frequency: 160.012 MHz; Duty Cycle: 1:1

Medium parameters used: $f = 160.012$ MHz; $\sigma = 0.767$ S/m; $\epsilon_r = 51.013$; $\rho = 1000$ kg/m³

Phantom section: Flat Section

DASY5 Configuration:

- Probe: EX3DV4 - SN7329; ConvF(12.88, 12.88, 12.88); Calibrated: 2018/1/22;
- Sensor-Surface: 1.4mm (Mechanical Surface Detection)
- Electronics: DAE4 Sn1459; Calibrated: 2017/9/15
- Phantom: ELI v8.0; Type: QDOVA004AA; Serial: 2051
- Measurement SW: DASY52, Version 52.8 (8);

Area Scan (71x151x1): Interpolated grid: dx=1.500 mm, dy=1.500 mm

Maximum value of SAR (interpolated) = 2.38 W/kg

Zoom Scan (5x7x7)/Cube 0: Measurement grid: dx=8mm, dy=8mm, dz=5mm

Reference Value = 49.25 V/m; Power Drift = -0.11 dB

Peak SAR (extrapolated) = 2.50 W/kg

SAR(1 g) = 1.72 W/kg; SAR(10 g) = 1.36 W/kg

Maximum value of SAR (measured) = 2.17 W/kg

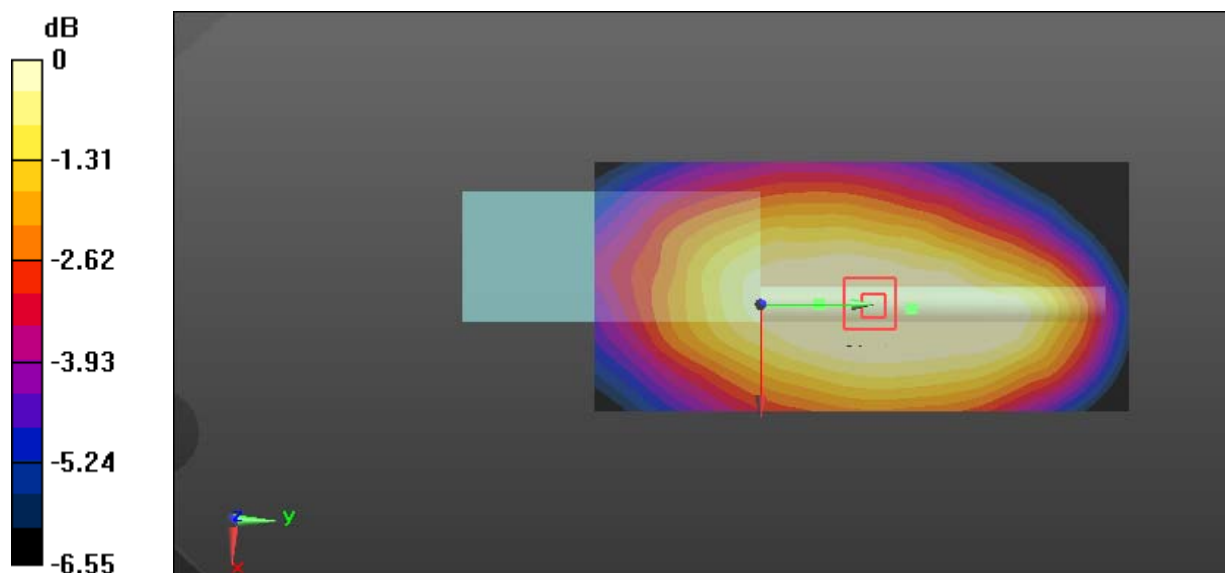

0 dB = 2.17 W/kg = 3.36 dBW/kg

Test Plot 20#: RDR4350V_PTT_4FSK 12.5kHz_Face Up_136.0125 MHz

DUT: Digital Two-Way Radio; Type: RDR4350V; Serial: 18030800425

Communication System: 4FSK; Frequency: 136.012 MHz; Duty Cycle: 1:2

Medium parameters used: $f = 136.012 \text{ MHz}$; $\sigma = 0.78 \text{ S/m}$; $\epsilon_r = 52.147$; $\rho = 1000 \text{ kg/m}^3$

Phantom section: Flat Section

DASY5 Configuration:

- Probe: EX3DV4 - SN7329; ConvF(12.88, 12.88, 12.88); Calibrated: 2018/1/22;
- Sensor-Surface: 1.4mm (Mechanical Surface Detection)
- Electronics: DAE4 Sn1459; Calibrated: 2017/9/15
- Phantom: ELI v8.0; Type: QDOVA004AA; Serial: 2051
- Measurement SW: DASY52, Version 52.8 (8);

Area Scan (71x151x1): Interpolated grid: $dx=1.500 \text{ mm}$, $dy=1.500 \text{ mm}$

Maximum value of SAR (interpolated) = 2.51 W/kg

Zoom Scan (5x5x7)/Cube 0: Measurement grid: $dx=8\text{mm}$, $dy=8\text{mm}$, $dz=5\text{mm}$

Reference Value = 48.26 V/m; Power Drift = -0.18 dB

Peak SAR (extrapolated) = 3.66 W/kg

SAR(1 g) = 1.76 W/kg; SAR(10 g) = 1.27 W/kg

Maximum value of SAR (measured) = 2.56 W/kg

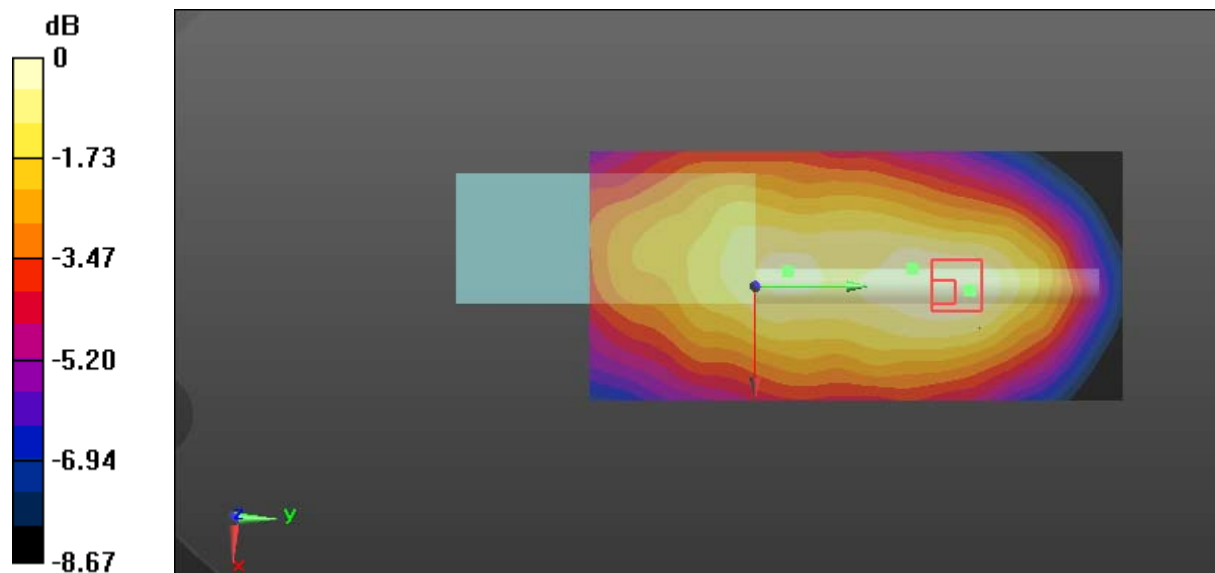

0 dB = 2.56 W/kg = 4.08 dBW/kg

Test Plot 21#: RDR4350V_PTT_4FSK 12.5kHz_Face Up_147.0125 MHz

DUT: Digital Two-Way Radio; Type: RDR4350V; Serial: 18030800425

Communication System: 4FSK; Frequency: 147.012 MHz; Duty Cycle: 1:2

Medium parameters used: $f = 147.012$ MHz; $\sigma = 0.779$ S/m; $\epsilon_r = 51.501$; $\rho = 1000$ kg/m³

Phantom section: Flat Section

DASY5 Configuration:

- Probe: EX3DV4 - SN7329; ConvF(12.88, 12.88, 12.88); Calibrated: 2018/1/22;
- Sensor-Surface: 1.4mm (Mechanical Surface Detection)
- Electronics: DAE4 Sn1459; Calibrated: 2017/9/15
- Phantom: ELI v8.0; Type: QDOVA004AA; Serial: 2051
- Measurement SW: DASY52, Version 52.8 (8);

Area Scan (71x151x1): Interpolated grid: dx=1.500 mm, dy=1.500 mm

Maximum value of SAR (interpolated) = 1.85 W/kg

Zoom Scan (5x5x7)/Cube 0: Measurement grid: dx=8mm, dy=8mm, dz=5mm

Reference Value = 41.99 V/m; Power Drift = -0.10 dB

Peak SAR (extrapolated) = 2.28 W/kg

SAR(1 g) = 1.43 W/kg; SAR(10 g) = 1.12 W/kg

Maximum value of SAR (measured) = 1.83 W/kg

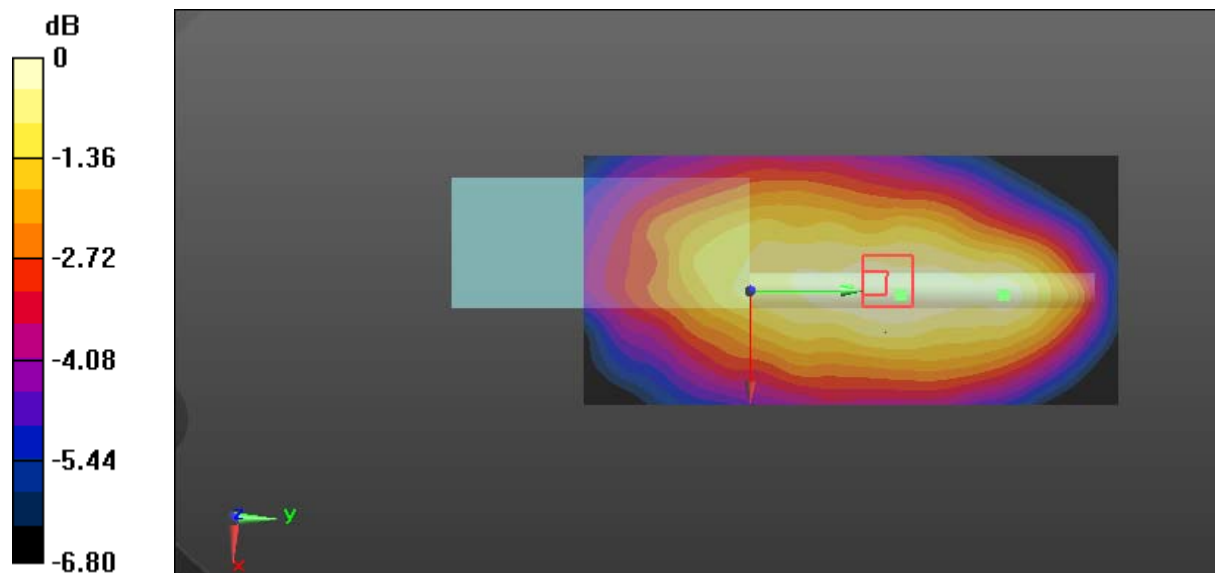

0 dB = 1.83 W/kg = 2.62 dBW/kg

Test Plot 22#: RDR4350V_PTT_4FSK 12.5kHz_Face Up_160.0125 MHz**DUT: Digital Two-Way Radio; Type: RDR4350V; Serial: 18030800425**

Communication System: 4FSK; Frequency: 160.012 MHz; Duty Cycle: 1:2

Medium parameters used: $f = 160.012$ MHz; $\sigma = 0.767$ S/m; $\epsilon_r = 51.013$; $\rho = 1000$ kg/m³

Phantom section: Flat Section

DASY5 Configuration:

- Probe: EX3DV4 - SN7329; ConvF(12.88, 12.88, 12.88); Calibrated: 2018/1/22;
- Sensor-Surface: 1.4mm (Mechanical Surface Detection)
- Electronics: DAE4 Sn1459; Calibrated: 2017/9/15
- Phantom: ELI v8.0; Type: QDOVA004AA; Serial: 2051
- Measurement SW: DASY52, Version 52.8 (8);

Area Scan (71x151x1): Interpolated grid: dx=1.500 mm, dy=1.500 mm

Maximum value of SAR (interpolated) = 0.914 W/kg

Zoom Scan (6x12x7)/Cube 0: Measurement grid: dx=8mm, dy=8mm, dz=5mm

Reference Value = 27.05 V/m; Power Drift = -0.11 dB

Peak SAR (extrapolated) = 1.20 W/kg

SAR(1 g) = 0.653 W/kg; SAR(10 g) = 0.517 W/kg

Maximum value of SAR (measured) = 0.901 W/kg

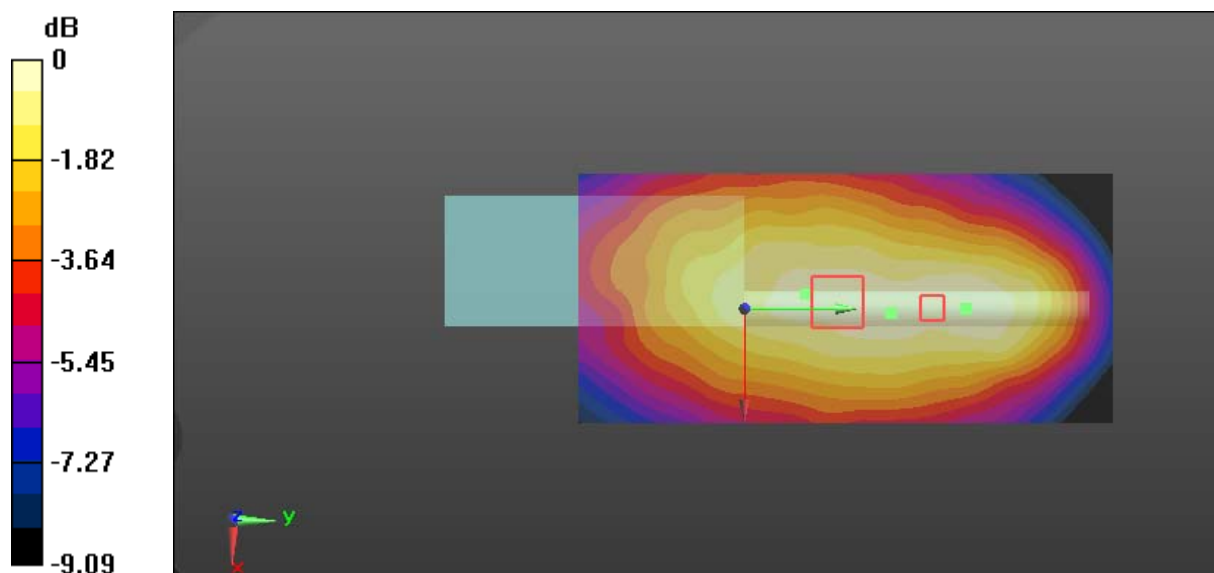

0 dB = 0.901 W/kg = -0.45 dBW/kg

Test Plot 23#: RDR4350V_PTT_FM 12.5kHz_Body Back_136.0125 MHz

DUT: Digital Two-Way Radio; Type: RDR4350V; Serial: 18030800425

Communication System: FM; Frequency: 136.012 MHz; Duty Cycle: 1:1

Medium parameters used: $f = 136.012 \text{ MHz}$; $\sigma = 0.787 \text{ S/m}$; $\epsilon_r = 61.04$; $\rho = 1000 \text{ kg/m}^3$

Phantom section: Flat Section

DASY5 Configuration:

- Probe: EX3DV4 - SN7329; ConvF(12.56, 12.56, 12.56); Calibrated: 2018/1/22;
- Sensor-Surface: 1.4mm (Mechanical Surface Detection)
- Electronics: DAE4 Sn1459; Calibrated: 2017/9/15
- Phantom: ELI v8.0; Type: QDOVA004AA; Serial: 2051
- Measurement SW: DASY52, Version 52.8 (8);

Area Scan (71x151x1): Interpolated grid: $dx=1.500 \text{ mm}$, $dy=1.500 \text{ mm}$

Maximum value of SAR (interpolated) = 16.0 W/kg

Zoom Scan (5x5x7)/Cube 0: Measurement grid: $dx=8\text{mm}$, $dy=8\text{mm}$, $dz=5\text{mm}$

Reference Value = 70.10 V/m; Power Drift = -0.14 dB

Peak SAR (extrapolated) = 30.1 W/kg

SAR(1 g) = 9.14 W/kg; SAR(10 g) = 4.75 W/kg

Maximum value of SAR (measured) = 17.6 W/kg

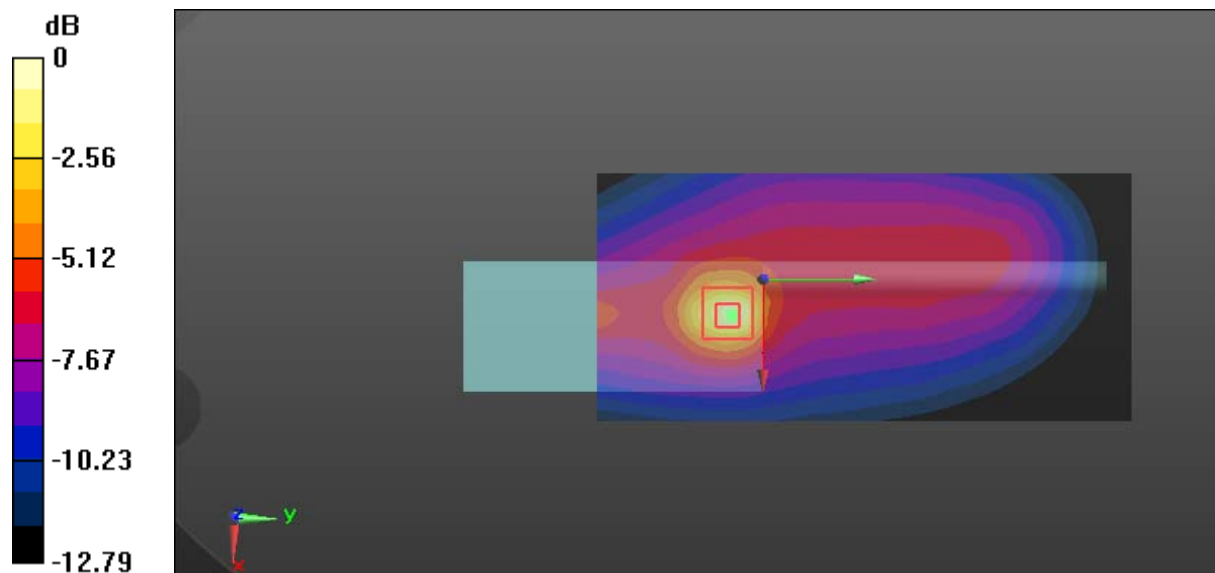

0 dB = 17.6 W/kg = 12.46 dBW/kg

Test Plot 24#: RDR4350V_PTT_FM 12.5kHz_Body Back_141 MHz

DUT: Digital Two-Way Radio; Type: RDR4350V; Serial: 18030800425

Communication System: FM; Frequency: 141 MHz; Duty Cycle: 1:1

Medium parameters used: $f = 141 \text{ MHz}$; $\sigma = 0.811 \text{ S/m}$; $\epsilon_r = 61.083$; $\rho = 1000 \text{ kg/m}^3$

Phantom section: Flat Section

DASY5 Configuration:

- Probe: EX3DV4 - SN7329; ConvF(12.56, 12.56, 12.56); Calibrated: 2018/1/22;
- Sensor-Surface: 1.4mm (Mechanical Surface Detection)
- Electronics: DAE4 Sn1459; Calibrated: 2017/9/15
- Phantom: ELI v8.0; Type: QDOVA004AA; Serial: 2051
- Measurement SW: DASY52, Version 52.8 (8);

Area Scan (71x151x1): Interpolated grid: $dx=1.500 \text{ mm}$, $dy=1.500 \text{ mm}$

Maximum value of SAR (interpolated) = 10.6 W/kg

Zoom Scan (5x5x7)/Cube 0: Measurement grid: $dx=8\text{mm}$, $dy=8\text{mm}$, $dz=5\text{mm}$

Reference Value = 62.24 V/m; Power Drift = -0.03 dB

Peak SAR (extrapolated) = 24.8 W/kg

SAR(1 g) = 6.99 W/kg; SAR(10 g) = 3.64 W/kg

Maximum value of SAR (measured) = 14.1 W/kg

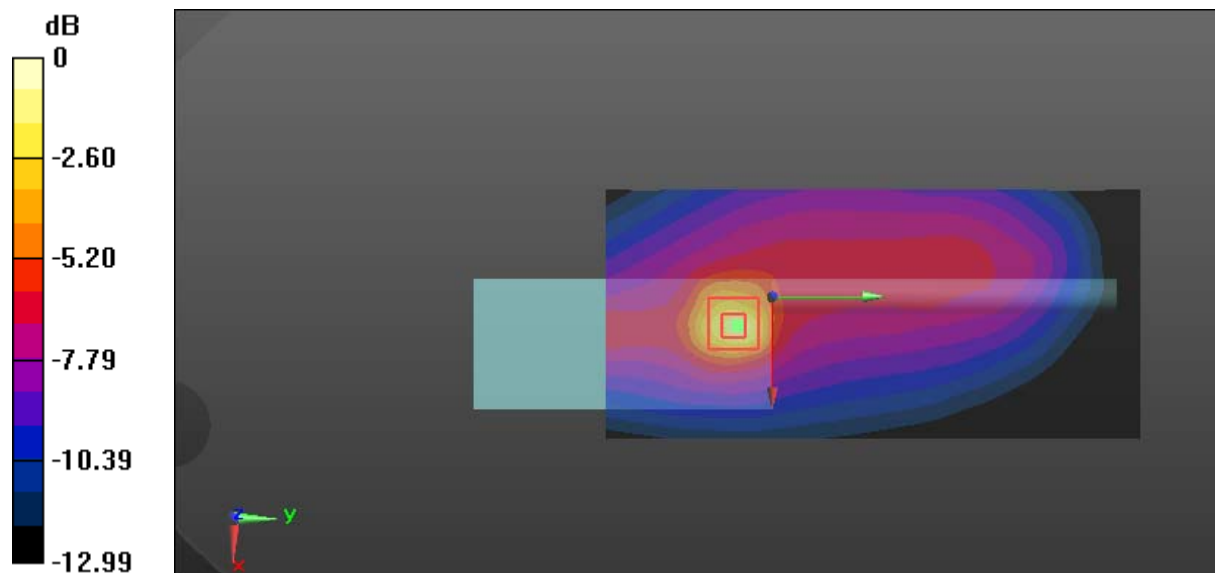

0 dB = 14.1 W/kg = 11.49 dBW/kg

Test Plot 25#: RDR4350V_PTT_FM 12.5kHz_Body Back_146.9875 MHz**DUT: Digital Two-Way Radio; Type: RDR4350V; Serial: 18030800425**

Communication System: FM; Frequency: 146.988 MHz; Duty Cycle: 1:1

Medium parameters used: $f = 146.988$ MHz; $\sigma = 0.813$ S/m; $\epsilon_r = 60.675$; $\rho = 1000$ kg/m³

Phantom section: Flat Section

DASY5 Configuration:

- Probe: EX3DV4 - SN7329; ConvF(12.56, 12.56, 12.56); Calibrated: 2018/1/22;
- Sensor-Surface: 1.4mm (Mechanical Surface Detection)
- Electronics: DAE4 Sn1459; Calibrated: 2017/9/15
- Phantom: ELI v8.0; Type: QDOVA004AA; Serial: 2051
- Measurement SW: DASY52, Version 52.8 (8);

Area Scan (71x151x1): Interpolated grid: dx=1.500 mm, dy=1.500 mm

Maximum value of SAR (interpolated) = 6.16 W/kg

Zoom Scan (5x5x7)/Cube 0: Measurement grid: dx=8mm, dy=8mm, dz=5mm

Reference Value = 50.71 V/m; Power Drift = -0.11 dB

Peak SAR (extrapolated) = 11.9 W/kg

SAR(1 g) = 3.76 W/kg; SAR(10 g) = 2.05 W/kg

Maximum value of SAR (measured) = 7.00 W/kg

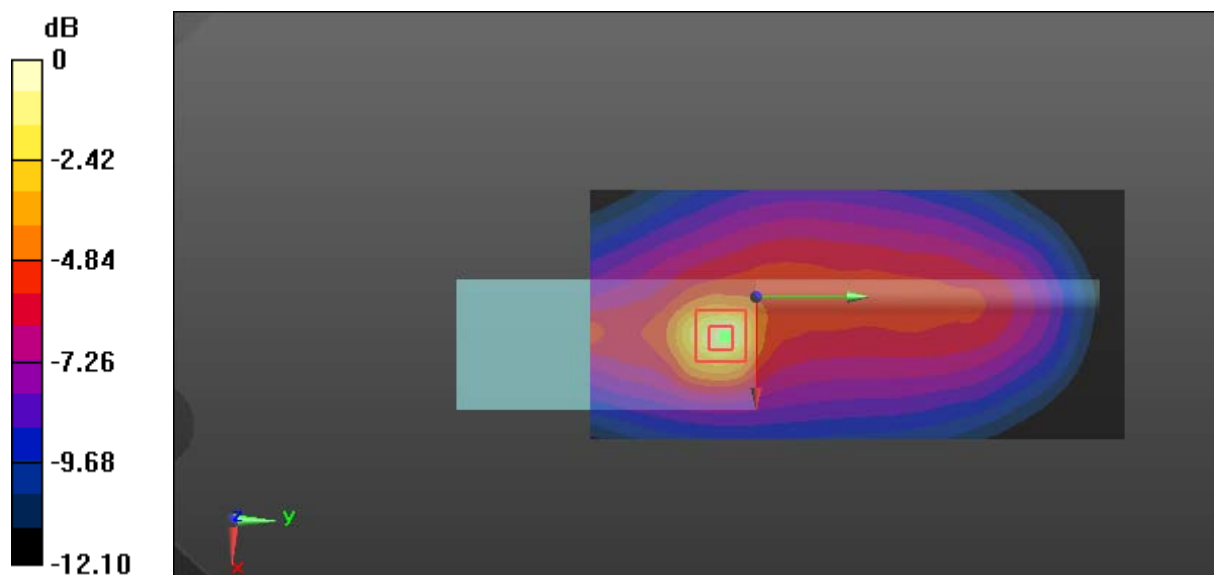

0 dB = 7.00 W/kg = 8.45 dBW/kg

Test Plot 26#: RDR4350V_PTT_FM 12.5kHz_Body Back_147.0125 MHz

DUT: Digital Two-Way Radio; Type: RDR4350V; Serial: 18030800425

Communication System: FM; Frequency: 147.012 MHz; Duty Cycle: 1:1

Medium parameters used: $f = 147.012 \text{ MHz}$; $\sigma = 0.819 \text{ S/m}$; $\epsilon_r = 60.669$; $\rho = 1000 \text{ kg/m}^3$

Phantom section: Flat Section

DASY5 Configuration:

- Probe: EX3DV4 - SN7329; ConvF(12.56, 12.56, 12.56); Calibrated: 2018/1/22;
- Sensor-Surface: 1.4mm (Mechanical Surface Detection)
- Electronics: DAE4 Sn1459; Calibrated: 2017/9/15
- Phantom: ELI v8.0; Type: QDOVA004AA; Serial: 2051
- Measurement SW: DASY52, Version 52.8 (8);

Area Scan (71x151x1): Interpolated grid: $dx=1.500 \text{ mm}$, $dy=1.500 \text{ mm}$

Maximum value of SAR (interpolated) = 9.36 W/kg

Zoom Scan (5x5x7)/Cube 0: Measurement grid: $dx=8\text{mm}$, $dy=8\text{mm}$, $dz=5\text{mm}$

Reference Value = 46.54 V/m; Power Drift = -0.12 dB

Peak SAR (extrapolated) = 23.2 W/kg

SAR(1 g) = 5.14 W/kg; SAR(10 g) = 2.42 W/kg

Maximum value of SAR (measured) = 11.2 W/kg

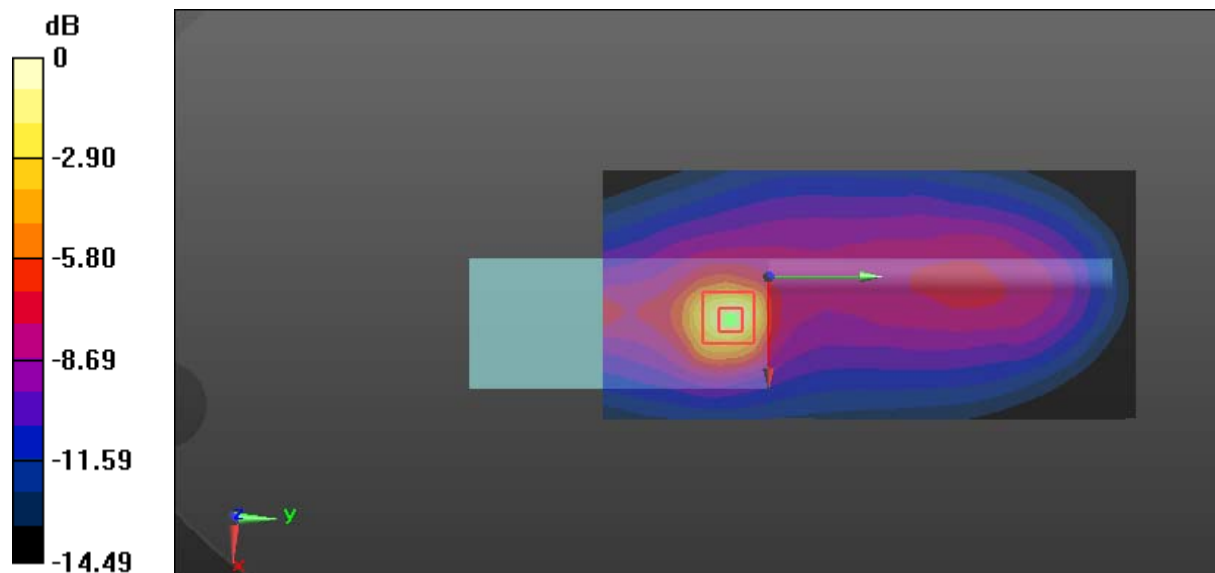

0 dB = 11.2 W/kg = 10.49 dBW/kg

Test Plot 27#: RDR4350V_PTT_FM 12.5kHz_Body Back_160.0125 MHz**DUT: Digital Two-Way Radio; Type: RDR4350V; Serial: 18030800425**

Communication System: FM; Frequency: 160.012 MHz; Duty Cycle: 1:1

Medium parameters used: $f = 160.012$ MHz; $\sigma = 0.827$ S/m; $\epsilon_r = 59.955$; $\rho = 1000$ kg/m³

Phantom section: Flat Section

DASY5 Configuration:

- Probe: EX3DV4 - SN7329; ConvF(12.56, 12.56, 12.56); Calibrated: 2018/1/22;
- Sensor-Surface: 1.4mm (Mechanical Surface Detection)
- Electronics: DAE4 Sn1459; Calibrated: 2017/9/15
- Phantom: ELI v8.0; Type: QDOVA004AA; Serial: 2051
- Measurement SW: DASY52, Version 52.8 (8);

Area Scan (71x151x1): Interpolated grid: dx=1.500 mm, dy=1.500 mm

Maximum value of SAR (interpolated) = 5.38 W/kg

Zoom Scan (5x5x7)/Cube 0: Measurement grid: dx=8mm, dy=8mm, dz=5mm

Reference Value = 43.94 V/m; Power Drift = -0.04 dB

Peak SAR (extrapolated) = 8.94 W/kg

SAR(1 g) = 2.86 W/kg; SAR(10 g) = 1.58 W/kg

Maximum value of SAR (measured) = 5.13 W/kg

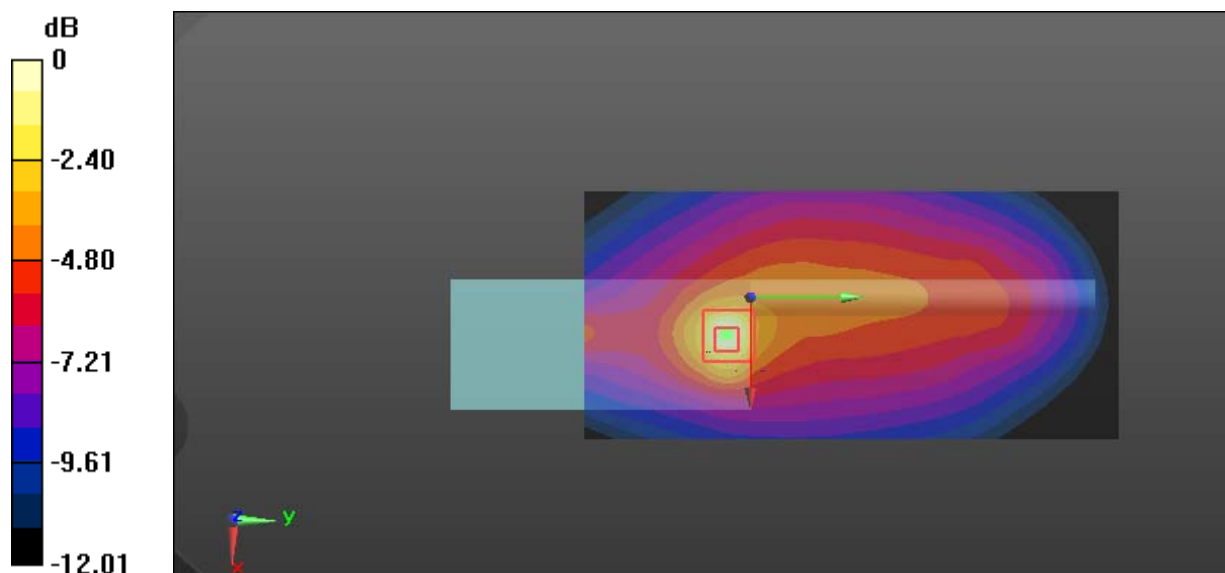

0 dB = 5.13 W/kg = 7.10 dBW/kg

Test Plot 28#: RDR4350V_PTT_4FSK 12.5kHz_Body Back_136.0125 MHz**DUT: Digital Two-Way Radio; Type: RDR4350V; Serial: 18030800425**

Communication System: 4FSK; Frequency: 136.012 MHz; Duty Cycle: 1:2

Medium parameters used: $f = 136.012$ MHz; $\sigma = 0.787$ S/m; $\epsilon_r = 61.04$; $\rho = 1000$ kg/m³

Phantom section: Flat Section

DASY5 Configuration:

- Probe: EX3DV4 - SN7329; ConvF(12.56, 12.56, 12.56); Calibrated: 2018/1/22;
- Sensor-Surface: 1.4mm (Mechanical Surface Detection)
- Electronics: DAE4 Sn1459; Calibrated: 2017/9/15
- Phantom: ELI v8.0; Type: QDOVA004AA; Serial: 2051
- Measurement SW: DASY52, Version 52.8 (8);

Area Scan (71x151x1): Interpolated grid: dx=1.500 mm, dy=1.500 mm

Maximum value of SAR (interpolated) = 11.0 W/kg

Zoom Scan (5x5x7)/Cube 0: Measurement grid: dx=8mm, dy=8mm, dz=5mm

Reference Value = 60.19 V/m; Power Drift = -0.14 dB

Peak SAR (extrapolated) = 18.2 W/kg

SAR(1 g) = 5.85 W/kg; SAR(10 g) = 3.25 W/kg

Maximum value of SAR (measured) = 11.1 W/kg

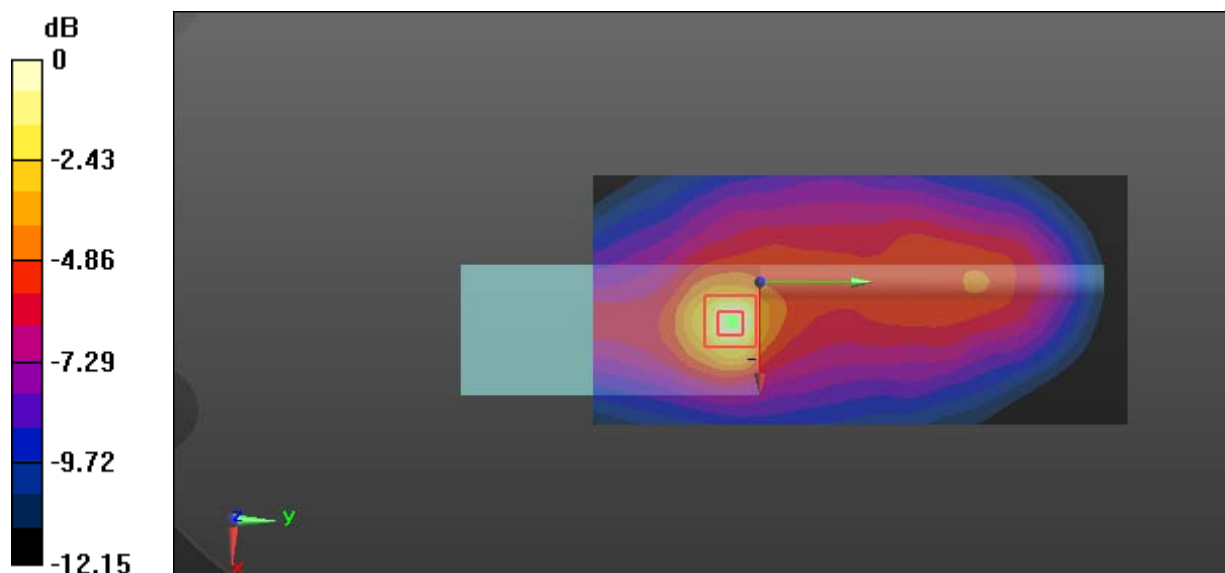

0 dB = 11.1 W/kg = 10.45 dBW/kg

Test Plot 29#: RDR4350V_PTT_4FSK 12.5kHz_Body Back_147.0125 MHz**DUT: Digital Two-Way Radio; Type: RDR4350V; Serial: 18030800425**

Communication System: 4FSK; Frequency: 147.012 MHz; Duty Cycle: 1:2

Medium parameters used: $f = 147.012$ MHz; $\sigma = 0.819$ S/m; $\epsilon_r = 60.669$; $\rho = 1000$ kg/m³

Phantom section: Flat Section

DASY5 Configuration:

- Probe: EX3DV4 - SN7329; ConvF(12.56, 12.56, 12.56); Calibrated: 2018/1/22;
- Sensor-Surface: 1.4mm (Mechanical Surface Detection)
- Electronics: DAE4 Sn1459; Calibrated: 2017/9/15
- Phantom: ELI v8.0; Type: QDOVA004AA; Serial: 2051
- Measurement SW: DASY52, Version 52.8 (8);

Area Scan (71x151x1): Interpolated grid: dx=1.500 mm, dy=1.500 mm

Maximum value of SAR (interpolated) = 4.94 W/kg

Zoom Scan (5x5x7)/Cube 0: Measurement grid: dx=8mm, dy=8mm, dz=5mm

Reference Value = 37.17 V/m; Power Drift = -0.19 dB

Peak SAR (extrapolated) = 9.37 W/kg

SAR(1 g) = 2.67 W/kg; SAR(10 g) = 1.40 W/kg

Maximum value of SAR (measured) = 5.13 W/kg

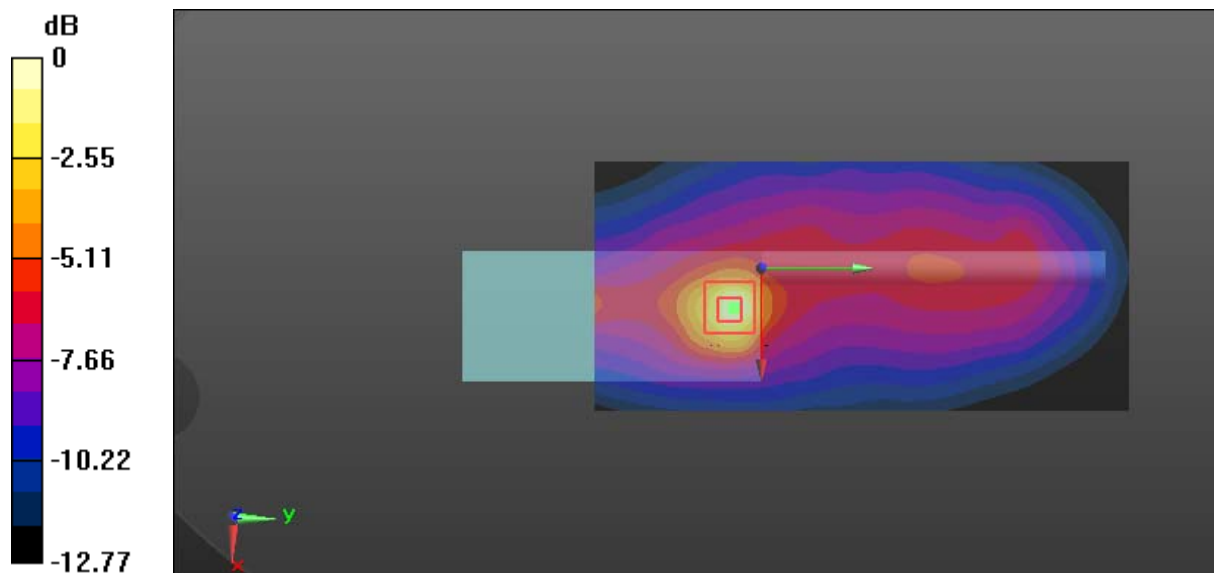

0 dB = 5.13 W/kg = 7.10 dBW/kg

Test Plot 30#: RDR4350V_PTT_4FSK 12.5kHz_Body Back_160.0125 MHz

DUT: Digital Two-Way Radio; Type: RDR4350V; Serial: 18030800425

Communication System: 4FSK; Frequency: 160.012 MHz; Duty Cycle: 1:2

Medium parameters used: $f = 160.012$ MHz; $\sigma = 0.827$ S/m; $\epsilon_r = 59.955$; $\rho = 1000$ kg/m³

Phantom section: Flat Section

DASY5 Configuration:

- Probe: EX3DV4 - SN7329; ConvF(12.56, 12.56, 12.56); Calibrated: 2018/1/22;
- Sensor-Surface: 1.4mm (Mechanical Surface Detection)
- Electronics: DAE4 Sn1459; Calibrated: 2017/9/15
- Phantom: ELI v8.0; Type: QDOVA004AA; Serial: 2051
- Measurement SW: DASY52, Version 52.8 (8);

Area Scan (71x151x1): Interpolated grid: dx=1.500 mm, dy=1.500 mm

Maximum value of SAR (interpolated) = 2.14 W/kg

Zoom Scan (5x5x7)/Cube 0: Measurement grid: dx=8mm, dy=8mm, dz=5mm

Reference Value = 29.01 V/m; Power Drift = -0.11 dB

Peak SAR (extrapolated) = 3.91 W/kg

SAR(1 g) = 1.28 W/kg; SAR(10 g) = 0.710 W/kg

Maximum value of SAR (measured) = 2.27 W/kg

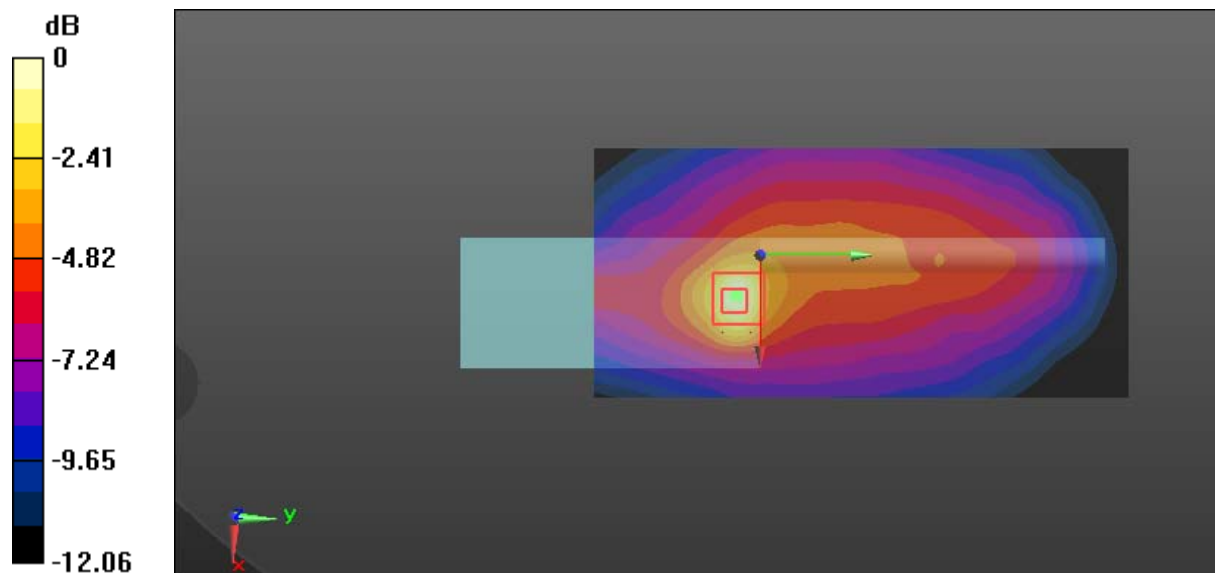

0 dB = 2.27 W/kg = 3.56 dBW/kg

Test Plot 31#: RDR4350V_PTT_FM 12.5kHz_Body Back_136.0125 MHz Headset 1**DUT: Digital Two-Way Radio; Type: RDR4350V; Serial: 18030800425**

Communication System: FM; Frequency: 136.012 MHz; Duty Cycle: 1:1

Medium parameters used: $f = 136.012$ MHz; $\sigma = 0.787$ S/m; $\epsilon_r = 61.04$; $\rho = 1000$ kg/m³

Phantom section: Flat Section

DASY5 Configuration:

- Probe: EX3DV4 - SN7329; ConvF(12.56, 12.56, 12.56); Calibrated: 2018/1/22;
- Sensor-Surface: 1.4mm (Mechanical Surface Detection)
- Electronics: DAE4 Sn1459; Calibrated: 2017/9/15
- Phantom: ELI v8.0; Type: QDOVA004AA; Serial: 2051
- Measurement SW: DASY52, Version 52.8 (8);

Area Scan (71x151x1): Interpolated grid: dx=1.500 mm, dy=1.500 mm

Maximum value of SAR (interpolated) = 12.7 W/kg

Zoom Scan (5x5x7)/Cube 0: Measurement grid: dx=8mm, dy=8mm, dz=5mm

Reference Value = 63.69 V/m; Power Drift = -0.09 dB

Peak SAR (extrapolated) = 22.2 W/kg

SAR(1 g) = 6.51 W/kg; SAR(10 g) = 3.45 W/kg

Maximum value of SAR (measured) = 12.7 W/kg

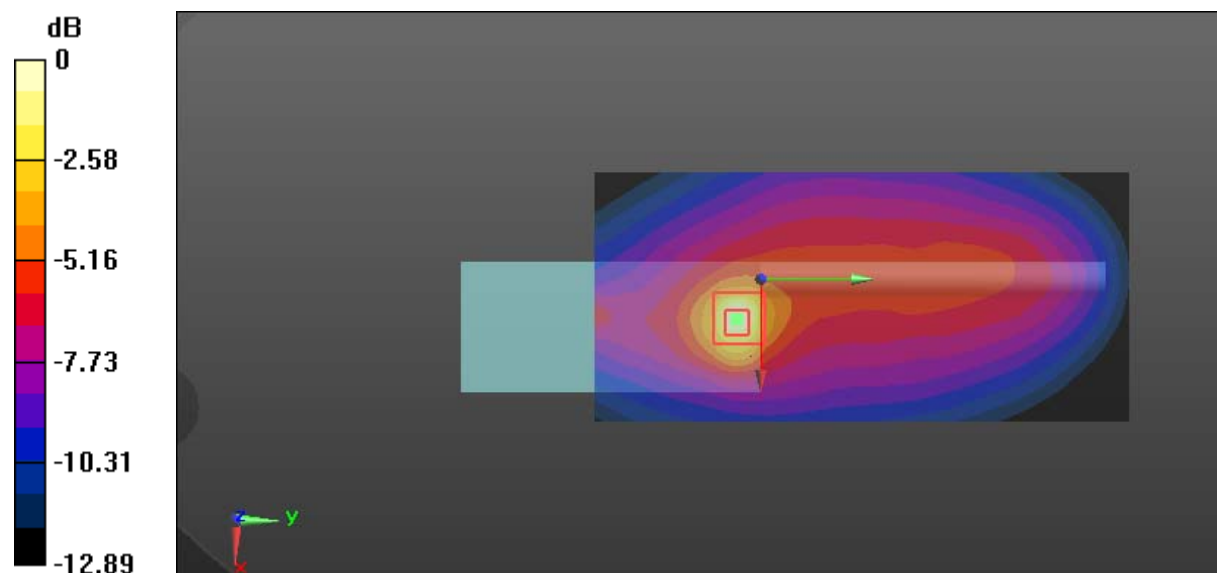

0 dB = 12.7 W/kg = 11.04 dBW/kg

Test Plot 32#: RDR4350V_PTT_FM 12.5kHz_Body Back_136.0125 MHz Headset 2**DUT: Digital Two-Way Radio; Type: RDR4350V; Serial: 18030800425**

Communication System: FM; Frequency: 136.012 MHz; Duty Cycle: 1:1

Medium parameters used: $f = 136.012$ MHz; $\sigma = 0.787$ S/m; $\epsilon_r = 61.04$; $\rho = 1000$ kg/m³

Phantom section: Flat Section

DASY5 Configuration:

- Probe: EX3DV4 - SN7329; ConvF(12.56, 12.56, 12.56); Calibrated: 2018/1/22;
- Sensor-Surface: 1.4mm (Mechanical Surface Detection)
- Electronics: DAE4 Sn1459; Calibrated: 2017/9/15
- Phantom: ELI v8.0; Type: QDOVA004AA; Serial: 2051
- Measurement SW: DASY52, Version 52.8 (8);

Area Scan (71x151x1): Interpolated grid: dx=1.500 mm, dy=1.500 mm

Maximum value of SAR (interpolated) = 15.4 W/kg

Zoom Scan (5x5x7)/Cube 0: Measurement grid: dx=8mm, dy=8mm, dz=5mm

Reference Value = 63.99 V/m; Power Drift = -0.15 dB

Peak SAR (extrapolated) = 23.8 W/kg

SAR(1 g) = 6.49 W/kg; SAR(10 g) = 3.28 W/kg

Maximum value of SAR (measured) = 13.5 W/kg

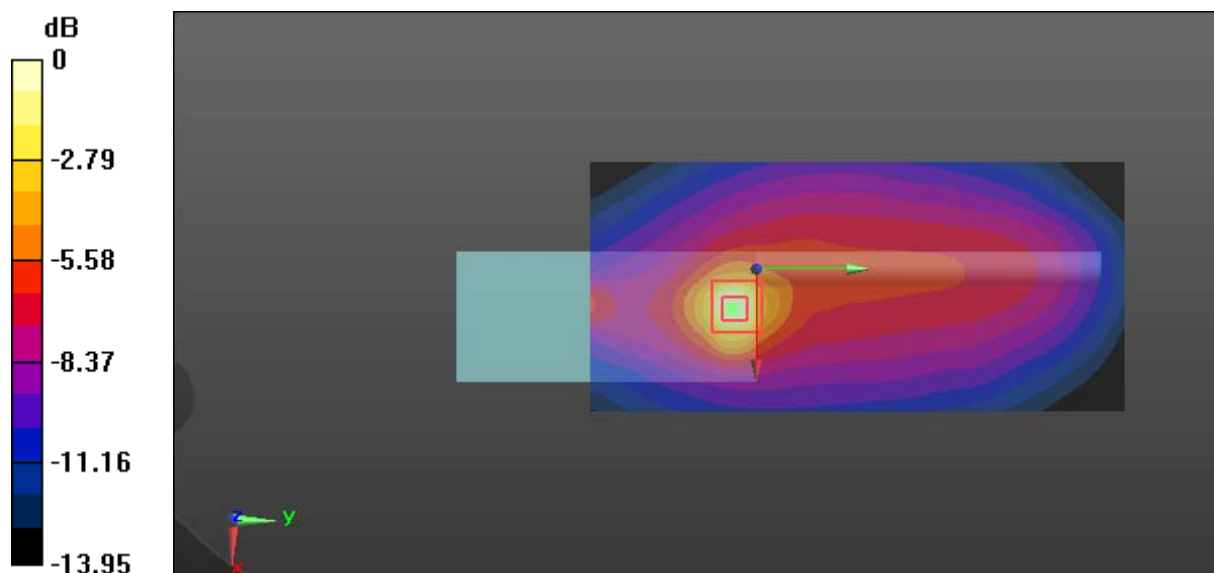

0 dB = 13.5 W/kg = 11.30 dBW/kg

Test Plot 33#: RDR4380V_PTT_FM 12.5kHz_Face Up_136.0125 MHz**DUT: Digital Two-Way Radio; Type: RDR4380V; Serial: 18030800428**

Communication System: FM; Frequency: 136.012 MHz; Duty Cycle: 1:1

Medium parameters used: $f = 136.012$ MHz; $\sigma = 0.78$ S/m; $\epsilon_r = 52.147$; $\rho = 1000$ kg/m³

Phantom section: Flat Section

DASY5 Configuration:

- Probe: EX3DV4 - SN7329; ConvF(12.88, 12.88, 12.88); Calibrated: 2018/1/22;
- Sensor-Surface: 1.4mm (Mechanical Surface Detection)
- Electronics: DAE4 Sn1459; Calibrated: 2017/9/15
- Phantom: ELI v8.0; Type: QDOVA004AA; Serial: 2051
- Measurement SW: DASY52, Version 52.8 (8);

Area Scan (71x151x1): Interpolated grid: dx=1.500 mm, dy=1.500 mm

Maximum value of SAR (interpolated) = 4.45 W/kg

Zoom Scan (5x5x7)/Cube 0: Measurement grid: dx=8mm, dy=8mm, dz=5mm

Reference Value = 64.14 V/m; Power Drift = -0.12 dB

Peak SAR (extrapolated) = 5.67 W/kg

SAR(1 g) = 3.25 W/kg; SAR(10 g) = 2.44 W/kg

Maximum value of SAR (measured) = 4.49 W/kg

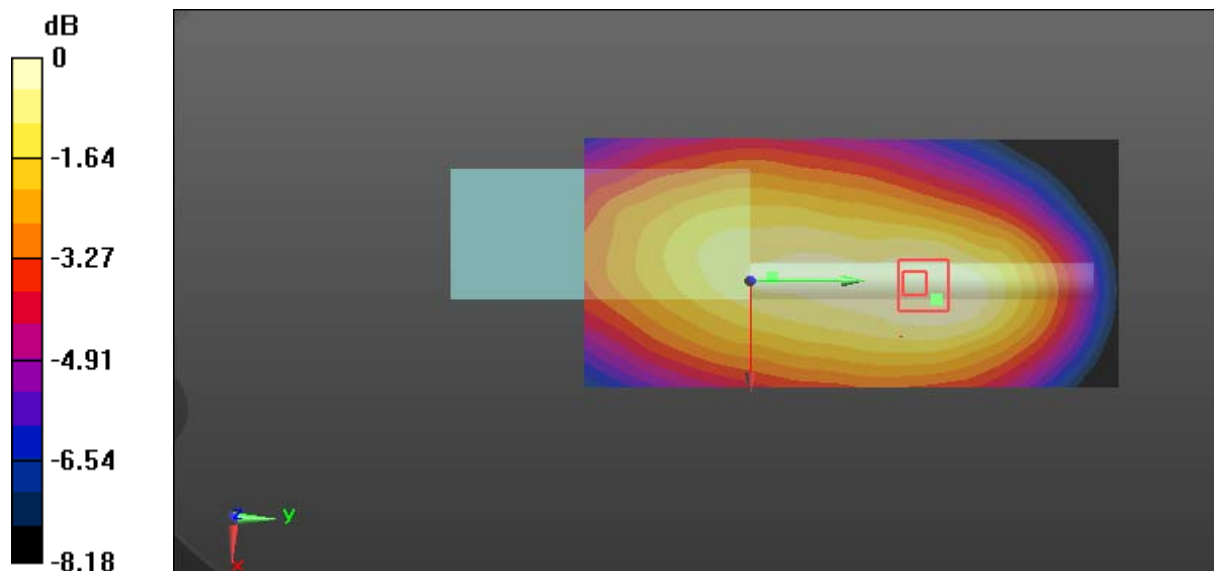

0 dB = 4.49 W/kg = 6.52 dBW/kg

Test Plot 34#: RDR4380V_PTT_FM 12.5kHz_Face Up_147.0125 MHz

DUT: Digital Two-Way Radio; Type: RDR4380V; Serial: 18030800428

Communication System: FM; Frequency: 147.012 MHz; Duty Cycle: 1:1

Medium parameters used: $f = 147.012 \text{ MHz}$; $\sigma = 0.779 \text{ S/m}$; $\epsilon_r = 51.501$; $\rho = 1000 \text{ kg/m}^3$

Phantom section: Flat Section

DASY5 Configuration:

- Probe: EX3DV4 - SN7329; ConvF(12.88, 12.88, 12.88); Calibrated: 2018/1/22;
- Sensor-Surface: 1.4mm (Mechanical Surface Detection)
- Electronics: DAE4 Sn1459; Calibrated: 2017/9/15
- Phantom: ELI v8.0; Type: QDOVA004AA; Serial: 2051
- Measurement SW: DASY52, Version 52.8 (8);

Area Scan (71x151x1): Interpolated grid: $dx=1.500 \text{ mm}$, $dy=1.500 \text{ mm}$

Maximum value of SAR (interpolated) = 2.30 W/kg

Zoom Scan (5x5x7)/Cube 0: Measurement grid: $dx=8\text{mm}$, $dy=8\text{mm}$, $dz=5\text{mm}$

Reference Value = 46.40 V/m; Power Drift = -0.10 dB

Peak SAR (extrapolated) = 2.59 W/kg

SAR(1 g) = 1.5 W/kg; SAR(10 g) = 1.15 W/kg

Maximum value of SAR (measured) = 1.97 W/kg

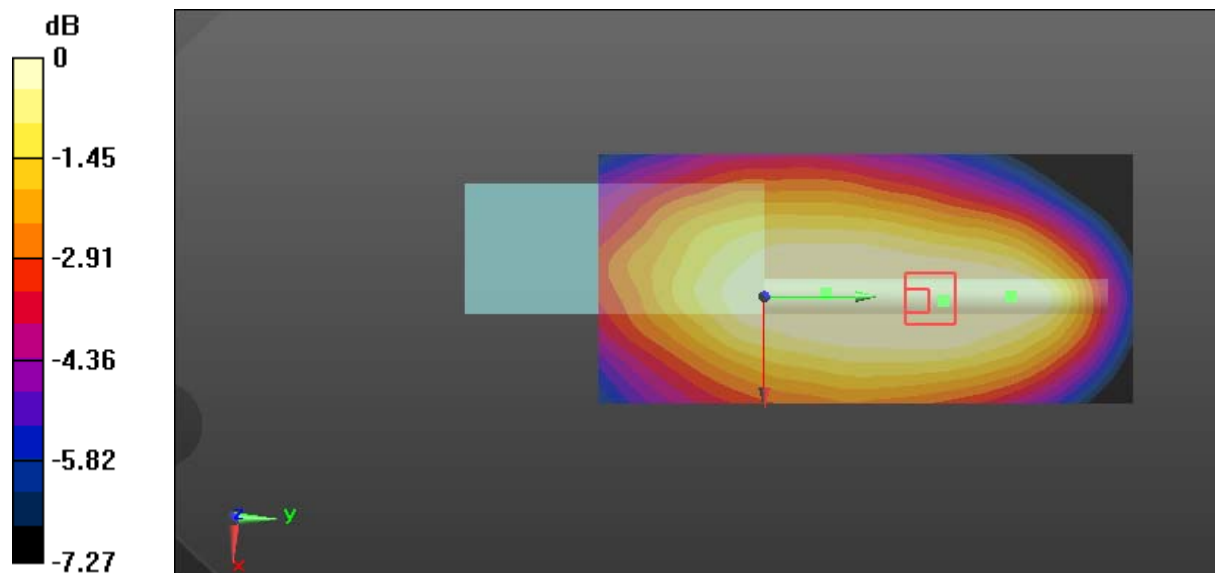

0 dB = 1.97 W/kg = 2.94 dBW/kg

Test Plot 35#: RDR4380V_PTT_FM 12.5kHz_Face Up_160.0125 MHz

DUT: Digital Two-Way Radio; Type: RDR4380V; Serial: 18030800428

Communication System: FM; Frequency: 160.012 MHz; Duty Cycle: 1:1

Medium parameters used: $f = 160.012$ MHz; $\sigma = 0.767$ S/m; $\epsilon_r = 51.013$; $\rho = 1000$ kg/m³

Phantom section: Flat Section

DASY5 Configuration:

- Probe: EX3DV4 - SN7329; ConvF(12.88, 12.88, 12.88); Calibrated: 2018/1/22;
- Sensor-Surface: 1.4mm (Mechanical Surface Detection)
- Electronics: DAE4 Sn1459; Calibrated: 2017/9/15
- Phantom: ELI v8.0; Type: QDOVA004AA; Serial: 2051
- Measurement SW: DASY52, Version 52.8 (8);

Area Scan (71x151x1): Interpolated grid: dx=1.500 mm, dy=1.500 mm

Maximum value of SAR (interpolated) = 2.24 W/kg

Zoom Scan (5x8x7)/Cube 0: Measurement grid: dx=8mm, dy=8mm, dz=5mm

Reference Value = 44.75 V/m; Power Drift = -0.05 dB

Peak SAR (extrapolated) = 2.46 W/kg

SAR(1 g) = 1.64 W/kg; SAR(10 g) = 1.3 W/kg

Maximum value of SAR (measured) = 2.06 W/kg

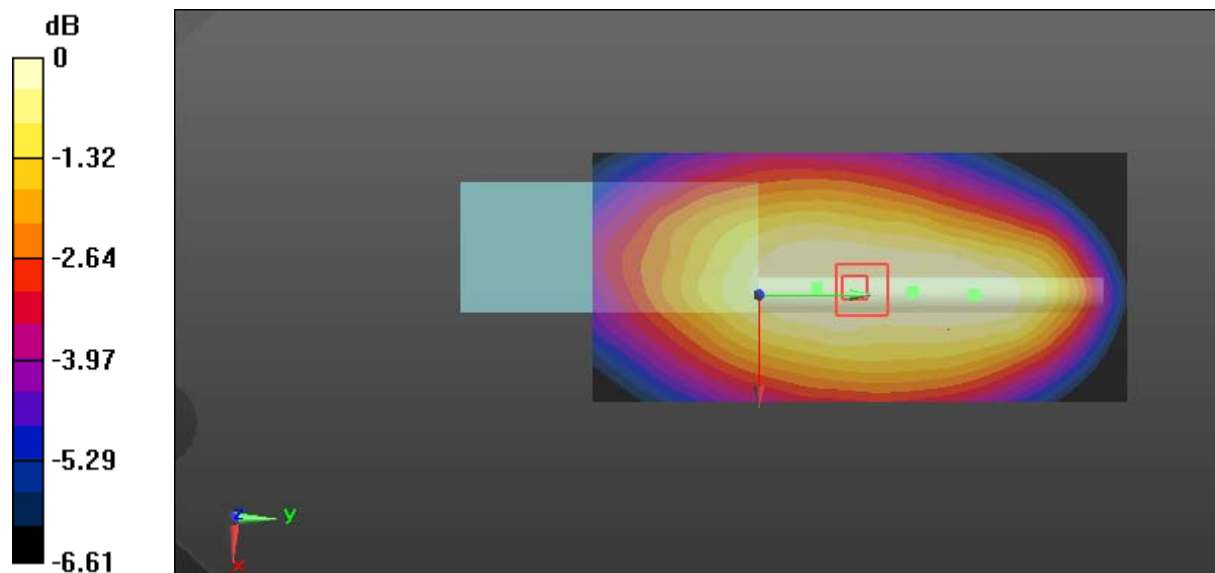

0 dB = 2.06 W/kg = 3.14 dBW/kg

Test Plot 36#: RDR4380V_PTT_4FSK 12.5kHz_Face Up_136.0125 MHz

DUT: Digital Two-Way Radio; Type: RDR4380V; Serial: 18030800428

Communication System: 4FSK; Frequency: 136.012 MHz; Duty Cycle: 1:2

Medium parameters used: $f = 136.012$ MHz; $\sigma = 0.78$ S/m; $\epsilon_r = 52.147$; $\rho = 1000$ kg/m³

Phantom section: Flat Section

DASY5 Configuration:

- Probe: EX3DV4 - SN7329; ConvF(12.88, 12.88, 12.88); Calibrated: 2018/1/22;
- Sensor-Surface: 1.4mm (Mechanical Surface Detection)
- Electronics: DAE4 Sn1459; Calibrated: 2017/9/15
- Phantom: ELI v8.0; Type: QDOVA004AA; Serial: 2051
- Measurement SW: DASY52, Version 52.8 (8);

Area Scan (71x151x1): Interpolated grid: dx=1.500 mm, dy=1.500 mm

Maximum value of SAR (interpolated) = 2.07 W/kg

Zoom Scan (5x5x7)/Cube 0: Measurement grid: dx=8mm, dy=8mm, dz=5mm

Reference Value = 43.90 V/m; Power Drift = -0.12 dB

Peak SAR (extrapolated) = 2.67 W/kg

SAR(1 g) = 1.48 W/kg; SAR(10 g) = 1.16 W/kg

Maximum value of SAR (measured) = 2.07 W/kg

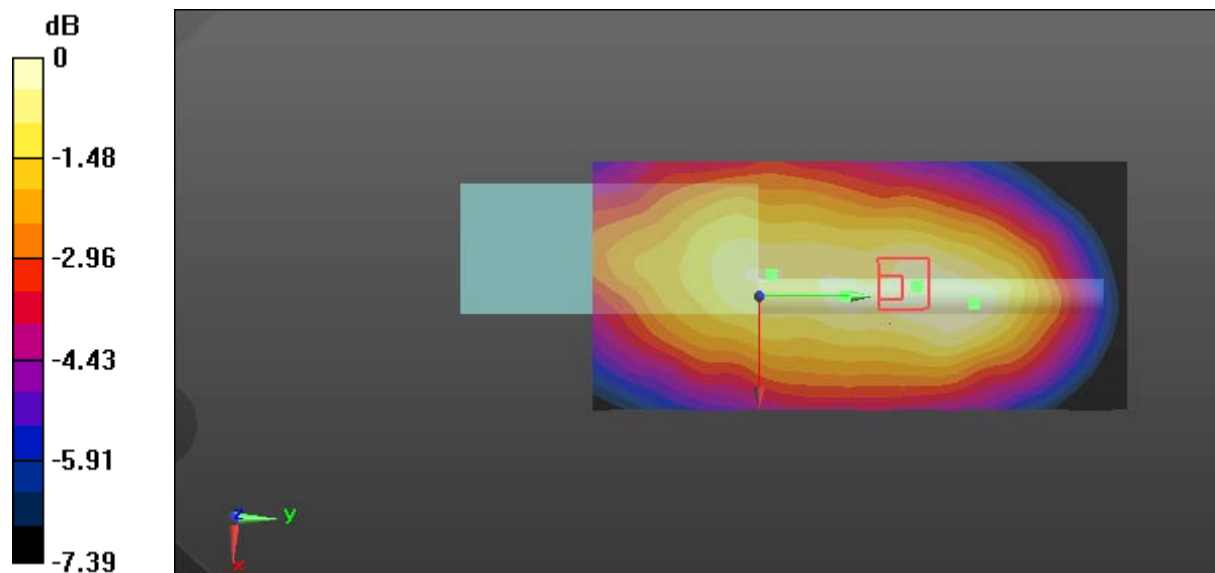

0 dB = 2.07 W/kg = 3.16 dBW/kg

Test Plot 37#: RDR4380V_PTT_4FSK 12.5kHz_Face Up_147.0125 MHz**DUT: Digital Two-Way Radio; Type: RDR4380V; Serial: 18030800428**

Communication System: 4FSK; Frequency: 147.012 MHz; Duty Cycle: 1:2

Medium parameters used: $f = 147.012$ MHz; $\sigma = 0.779$ S/m; $\epsilon_r = 51.501$; $\rho = 1000$ kg/m³

Phantom section: Flat Section

DASY5 Configuration:

- Probe: EX3DV4 - SN7329; ConvF(12.88, 12.88, 12.88); Calibrated: 2018/1/22;
- Sensor-Surface: 1.4mm (Mechanical Surface Detection)
- Electronics: DAE4 Sn1459; Calibrated: 2017/9/15
- Phantom: ELI v8.0; Type: QDOVA004AA; Serial: 2051
- Measurement SW: DASY52, Version 52.8 (8);

Area Scan (71x151x1): Interpolated grid: dx=1.500 mm, dy=1.500 mm

Maximum value of SAR (interpolated) = 0.983 W/kg

Zoom Scan (5x5x7)/Cube 0: Measurement grid: dx=8mm, dy=8mm, dz=5mm

Reference Value = 30.30 V/m; Power Drift = -0.11 dB

Peak SAR (extrapolated) = 1.20 W/kg

SAR(1 g) = 0.729 W/kg; SAR(10 g) = 0.567 W/kg

Maximum value of SAR (measured) = 0.966 W/kg

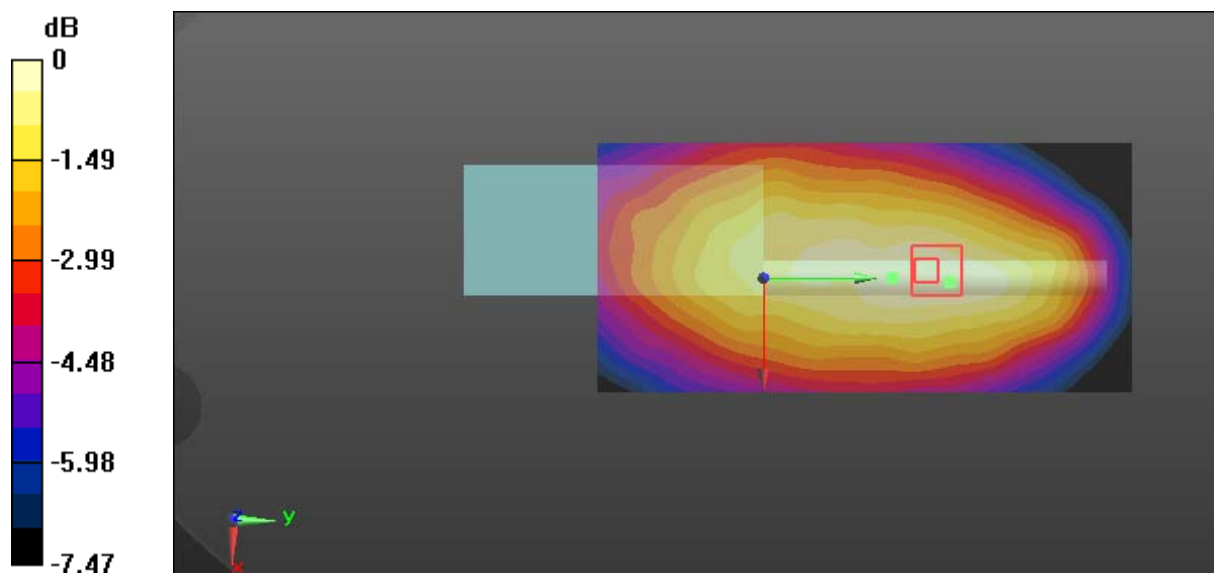

0 dB = 0.966 W/kg = -0.15 dBW/kg

Test Plot 38#: RDR4380V_PTT_4FSK 12.5kHz_Face Up_160.0125 MHz**DUT: Digital Two-Way Radio; Type: RDR4380V; Serial: 18030800428**

Communication System: 4FSK; Frequency: 160.012 MHz; Duty Cycle: 1:2

Medium parameters used: $f = 160.012$ MHz; $\sigma = 0.767$ S/m; $\epsilon_r = 51.013$; $\rho = 1000$ kg/m³

Phantom section: Flat Section

DASY5 Configuration:

- Probe: EX3DV4 - SN7329; ConvF(12.88, 12.88, 12.88); Calibrated: 2018/1/22;
- Sensor-Surface: 1.4mm (Mechanical Surface Detection)
- Electronics: DAE4 Sn1459; Calibrated: 2017/9/15
- Phantom: ELI v8.0; Type: QDOVA004AA; Serial: 2051
- Measurement SW: DASY52, Version 52.8 (8);

Area Scan (71x151x1): Interpolated grid: dx=1.500 mm, dy=1.500 mm

Maximum value of SAR (interpolated) = 0.913 W/kg

Zoom Scan (5x6x7)/Cube 0: Measurement grid: dx=8mm, dy=8mm, dz=5mm

Reference Value = 27.59 V/m; Power Drift = -0.05 dB

Peak SAR (extrapolated) = 1.04 W/kg

SAR(1 g) = 0.682 W/kg; SAR(10 g) = 0.542 W/kg

Maximum value of SAR (measured) = 0.880 W/kg

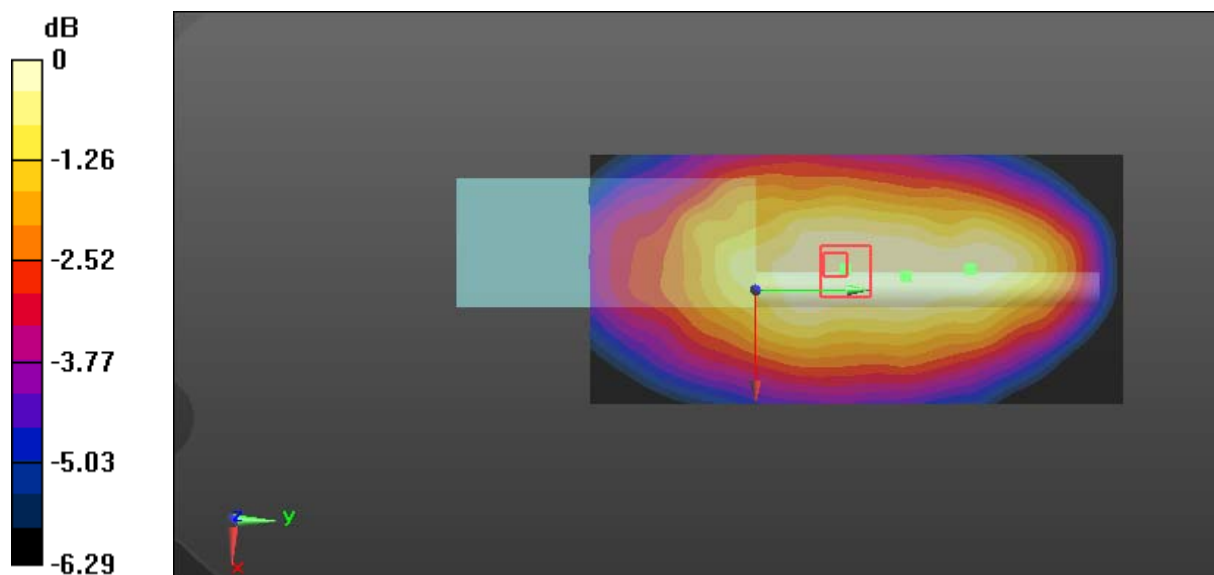

0 dB = 0.880 W/kg = -0.56 dBW/kg

Test Plot 39#: RDR4380V_PTT_FM 12.5kHz_Body Back_136.0125 MHz

DUT: Digital Two-Way Radio; Type: RDR4380V; Serial: 18030800428

Communication System: FM; Frequency: 136.012 MHz; Duty Cycle: 1:1

Medium parameters used: $f = 136.012$ MHz; $\sigma = 0.792$ S/m; $\epsilon_r = 62.278$; $\rho = 1000$ kg/m³

Phantom section: Flat Section

DASY5 Configuration:

- Probe: EX3DV4 - SN7329; ConvF(12.56, 12.56, 12.56); Calibrated: 2018/1/22;
- Sensor-Surface: 1.4mm (Mechanical Surface Detection)
- Electronics: DAE4 Sn1459; Calibrated: 2017/9/15
- Phantom: ELI v8.0; Type: QDOVA004AA; Serial: 2051
- Measurement SW: DASY52, Version 52.8 (8);

Area Scan (71x151x1): Interpolated grid: dx=1.500 mm, dy=1.500 mm

Maximum value of SAR (interpolated) = 13.1 W/kg

Zoom Scan (5x5x7)/Cube 0: Measurement grid: dx=8mm, dy=8mm, dz=5mm

Reference Value = 81.09 V/m; Power Drift = -0.14 dB

Peak SAR (extrapolated) = 26.6 W/kg

SAR(1 g) = 8.41 W/kg; SAR(10 g) = 4.53 W/kg

Maximum value of SAR (measured) = 15.9 W/kg

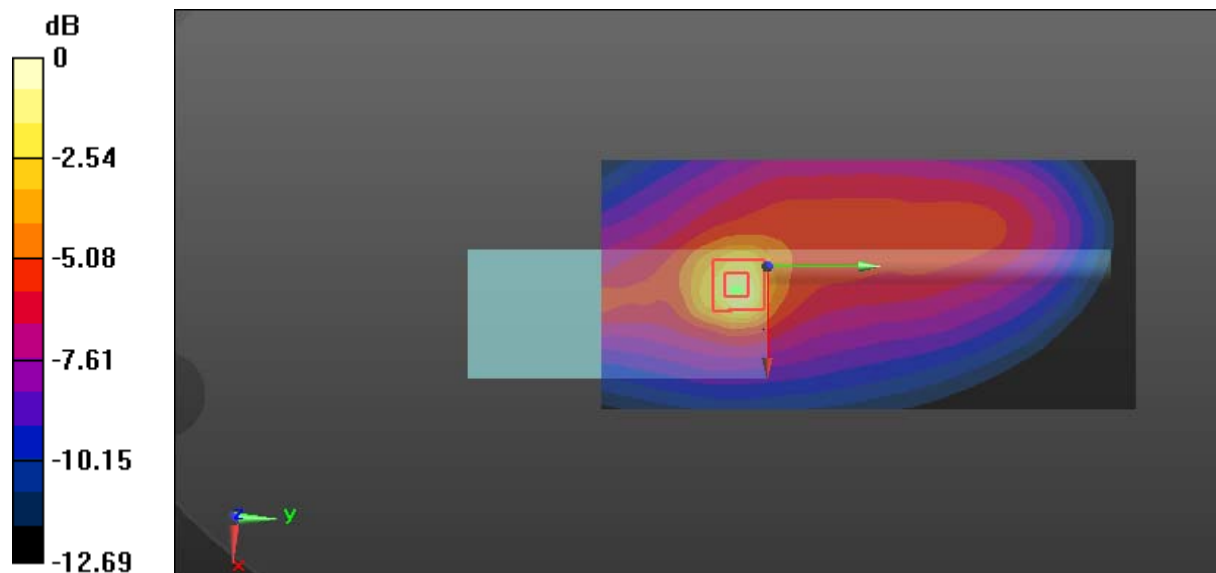

0 dB = 15.9 W/kg = 12.01 dBW/kg

Test Plot 40#: RDR4380V_PTT_FM 12.5kHz_Body Back_141 MHz

DUT: Digital Two-Way Radio; Type: RDR4380V; Serial: 18030800428

Communication System: FM; Frequency: 141 MHz; Duty Cycle: 1:1

Medium parameters used: $f = 141 \text{ MHz}$; $\sigma = 0.787 \text{ S/m}$; $\epsilon_r = 61.886$; $\rho = 1000 \text{ kg/m}^3$

Phantom section: Flat Section

DASY5 Configuration:

- Probe: EX3DV4 - SN7329; ConvF(12.56, 12.56, 12.56); Calibrated: 2018/1/22;
- Sensor-Surface: 1.4mm (Mechanical Surface Detection)
- Electronics: DAE4 Sn1459; Calibrated: 2017/9/15
- Phantom: ELI v8.0; Type: QDOVA004AA; Serial: 2051
- Measurement SW: DASY52, Version 52.8 (8);

Area Scan (71x151x1): Interpolated grid: $dx=1.500 \text{ mm}$, $dy=1.500 \text{ mm}$

Maximum value of SAR (interpolated) = 10.9 W/kg

Zoom Scan (5x5x7)/Cube 0: Measurement grid: $dx=8\text{mm}$, $dy=8\text{mm}$, $dz=5\text{mm}$

Reference Value = 58.18 V/m; Power Drift = 0.10 dB

Peak SAR (extrapolated) = 21.0 W/kg

SAR(1 g) = 6.64 W/kg; SAR(10 g) = 3.63 W/kg

Maximum value of SAR (measured) = 12.6 W/kg

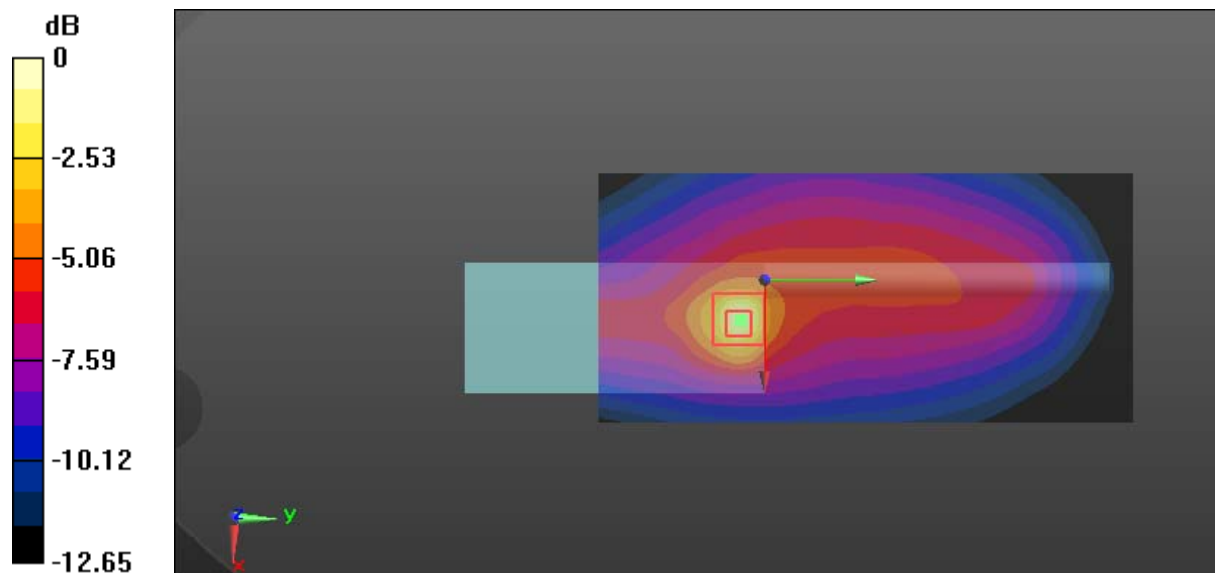

0 dB = 12.6 W/kg = 11.00 dBW/kg

Test Plot 41#: RDR4380V_PTT_FM 12.5kHz_Body Back_146.9875 MHz**DUT: Digital Two-Way Radio; Type: RDR4380V; Serial: 18030800428**

Communication System: FM; Frequency: 146.988 MHz; Duty Cycle: 1:1

Medium parameters used: $f = 146.988$ MHz; $\sigma = 0.812$ S/m; $\epsilon_r = 61.604$; $\rho = 1000$ kg/m³

Phantom section: Flat Section

DASY5 Configuration:

- Probe: EX3DV4 - SN7329; ConvF(12.56, 12.56, 12.56); Calibrated: 2018/1/22;
- Sensor-Surface: 1.4mm (Mechanical Surface Detection)
- Electronics: DAE4 Sn1459; Calibrated: 2017/9/15
- Phantom: ELI v8.0; Type: QDOVA004AA; Serial: 2051
- Measurement SW: DASY52, Version 52.8 (8);

Area Scan (71x151x1): Interpolated grid: dx=1.500 mm, dy=1.500 mm

Maximum value of SAR (interpolated) = 5.48 W/kg

Zoom Scan (5x5x7)/Cube 0: Measurement grid: dx=8mm, dy=8mm, dz=5mm

Reference Value = 48.72 V/m; Power Drift = -0.13 dB

Peak SAR (extrapolated) = 13.2 W/kg

SAR(1 g) = 3.65 W/kg; SAR(10 g) = 1.93 W/kg

Maximum value of SAR (measured) = 7.53 W/kg

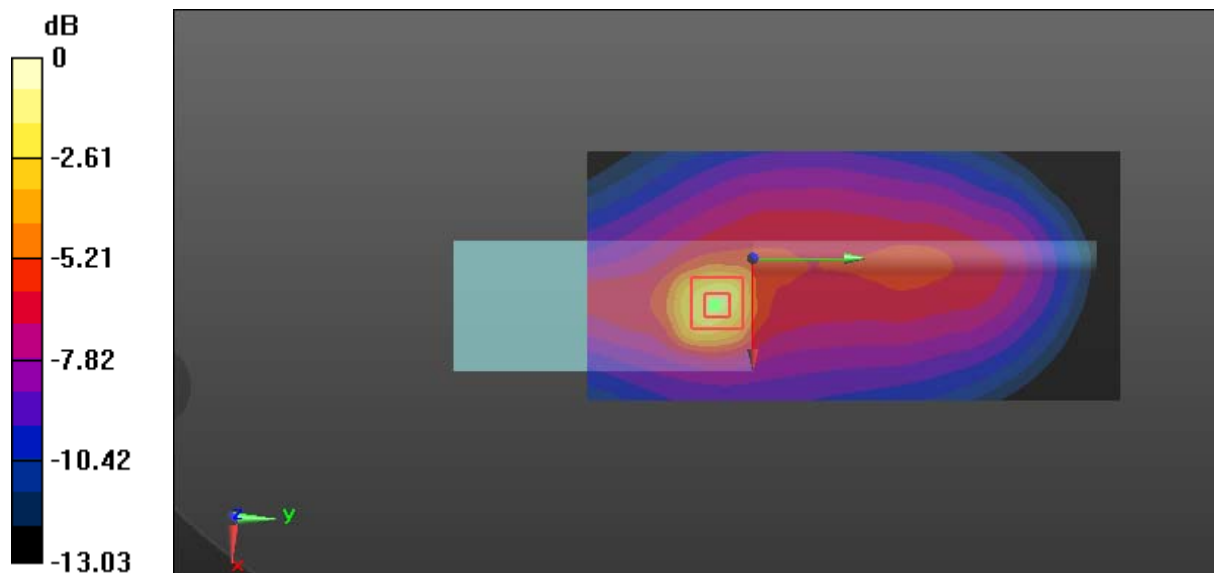

0 dB = 7.53 W/kg = 8.77 dBW/kg

Test Plot 42#: RDR4380V_PTT_FM 12.5kHz_Body Back_147.0125 MHz**DUT: Digital Two-Way Radio; Type: RDR4380V; Serial: 18030800428**

Communication System: FM; Frequency: 147.012 MHz; Duty Cycle: 1:1

Medium parameters used: $f = 147.012$ MHz; $\sigma = 0.809$ S/m; $\epsilon_r = 61.605$; $\rho = 1000$ kg/m³

Phantom section: Flat Section

DASY5 Configuration:

- Probe: EX3DV4 - SN7329; ConvF(12.56, 12.56, 12.56); Calibrated: 2018/1/22;
- Sensor-Surface: 1.4mm (Mechanical Surface Detection)
- Electronics: DAE4 Sn1459; Calibrated: 2017/9/15
- Phantom: ELI v8.0; Type: QDOVA004AA; Serial: 2051
- Measurement SW: DASY52, Version 52.8 (8);

Area Scan (71x151x1): Interpolated grid: dx=1.500 mm, dy=1.500 mm

Maximum value of SAR (interpolated) = 9.85 W/kg

Zoom Scan (5x5x7)/Cube 0: Measurement grid: dx=8mm, dy=8mm, dz=5mm

Reference Value = 45.18 V/m; Power Drift = -0.09 dB

Peak SAR (extrapolated) = 21.2 W/kg

SAR(1 g) = 5.04 W/kg; SAR(10 g) = 2.42 W/kg

Maximum value of SAR (measured) = 10.9 W/kg

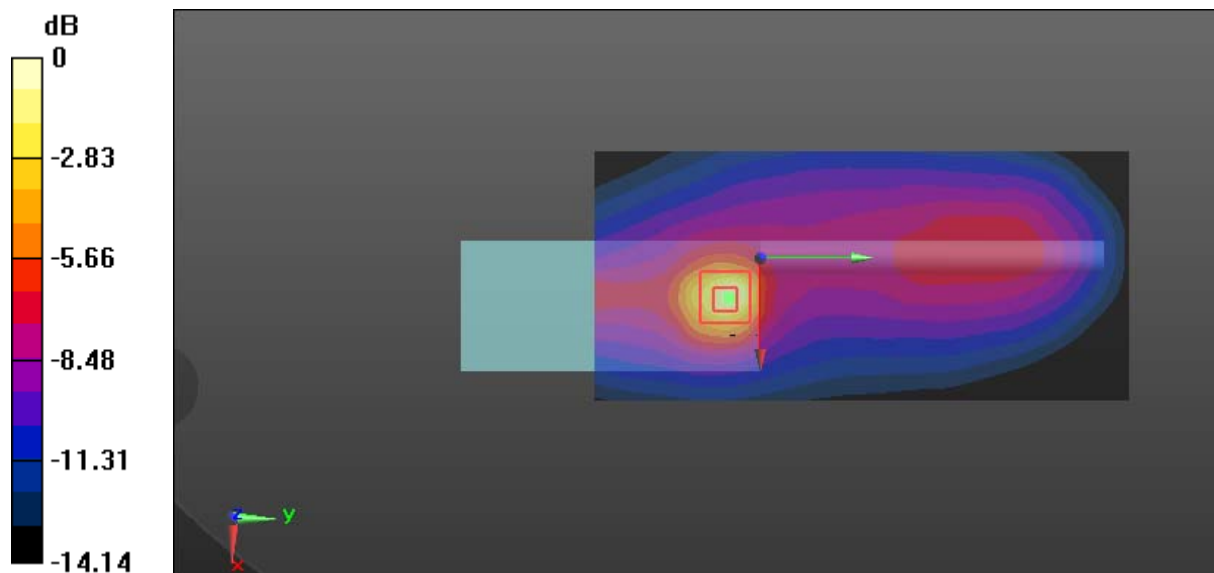

0 dB = 10.9 W/kg = 10.37 dBW/kg

Test Plot 43#: RDR4380V_PTT_FM 12.5kHz_Body Back_160.0125 MHz**DUT: Digital Two-Way Radio; Type: RDR4380V; Serial: 18030800428**

Communication System: FM; Frequency: 160.012 MHz; Duty Cycle: 1:1

Medium parameters used: $f = 160.012$ MHz; $\sigma = 0.825$ S/m; $\epsilon_r = 60.794$; $\rho = 1000$ kg/m³

Phantom section: Flat Section

DASY5 Configuration:

- Probe: EX3DV4 - SN7329; ConvF(12.56, 12.56, 12.56); Calibrated: 2018/1/22;
- Sensor-Surface: 1.4mm (Mechanical Surface Detection)
- Electronics: DAE4 Sn1459; Calibrated: 2017/9/15
- Phantom: ELI v8.0; Type: QDOVA004AA; Serial: 2051
- Measurement SW: DASY52, Version 52.8 (8);

Area Scan (71x151x1): Interpolated grid: dx=1.500 mm, dy=1.500 mm

Maximum value of SAR (interpolated) = 4.36 W/kg

Zoom Scan (5x5x7)/Cube 0: Measurement grid: dx=8mm, dy=8mm, dz=5mm

Reference Value = 46.22 V/m; Power Drift = -0.03 dB

Peak SAR (extrapolated) = 7.21 W/kg

SAR(1 g) = 2.5 W/kg; SAR(10 g) = 1.44 W/kg

Maximum value of SAR (measured) = 4.60 W/kg

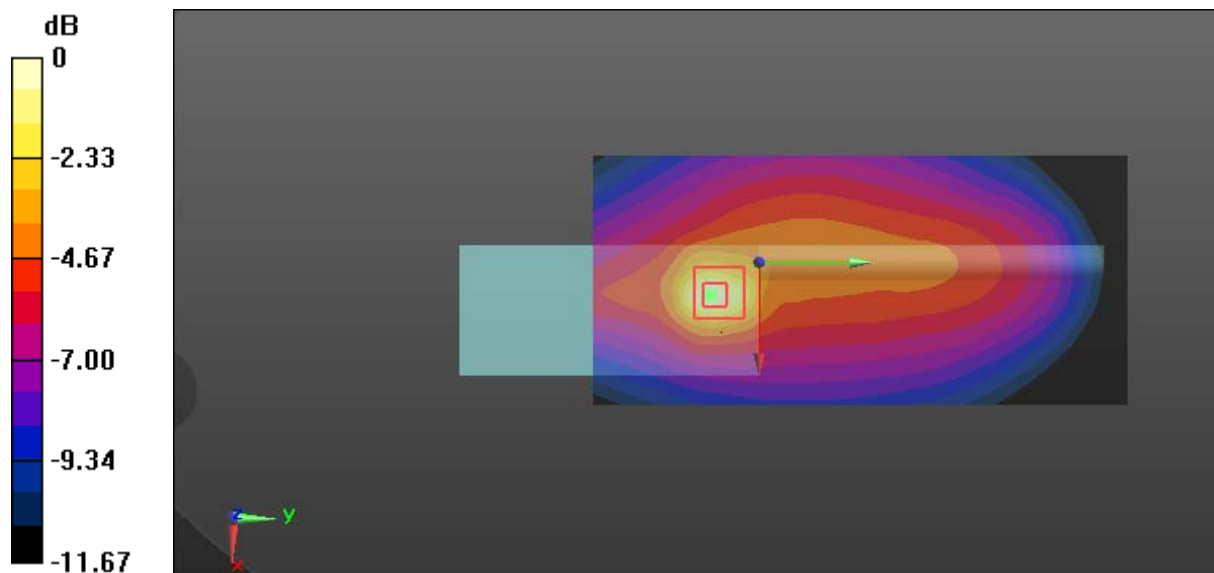

0 dB = 4.60 W/kg = 6.63 dBW/kg

Test Plot 44#: RDR4380V_PTT_4FSK 12.5kHz_Body Back_136.0125 MHz**DUT: Digital Two-Way Radio; Type: RDR4380V; Serial: 18030800428**

Communication System: 4FSK; Frequency: 136.012 MHz; Duty Cycle: 1:2

Medium parameters used: $f = 136.012$ MHz; $\sigma = 0.792$ S/m; $\epsilon_r = 62.278$; $\rho = 1000$ kg/m³

Phantom section: Flat Section

DASY5 Configuration:

- Probe: EX3DV4 - SN7329; ConvF(12.56, 12.56, 12.56); Calibrated: 2018/1/22;
- Sensor-Surface: 1.4mm (Mechanical Surface Detection)
- Electronics: DAE4 Sn1459; Calibrated: 2017/9/15
- Phantom: ELI v8.0; Type: QDOVA004AA; Serial: 2051
- Measurement SW: DASY52, Version 52.8 (8);

Area Scan (71x151x1): Interpolated grid: dx=1.500 mm, dy=1.500 mm

Maximum value of SAR (interpolated) = 8.09 W/kg

Zoom Scan (5x5x7)/Cube 0: Measurement grid: dx=8mm, dy=8mm, dz=5mm

Reference Value = 53.00 V/m; Power Drift = -0.15 dB

Peak SAR (extrapolated) = 18.8 W/kg

SAR(1 g) = 5.2 W/kg; SAR(10 g) = 2.61 W/kg

Maximum value of SAR (measured) = 10.4 W/kg

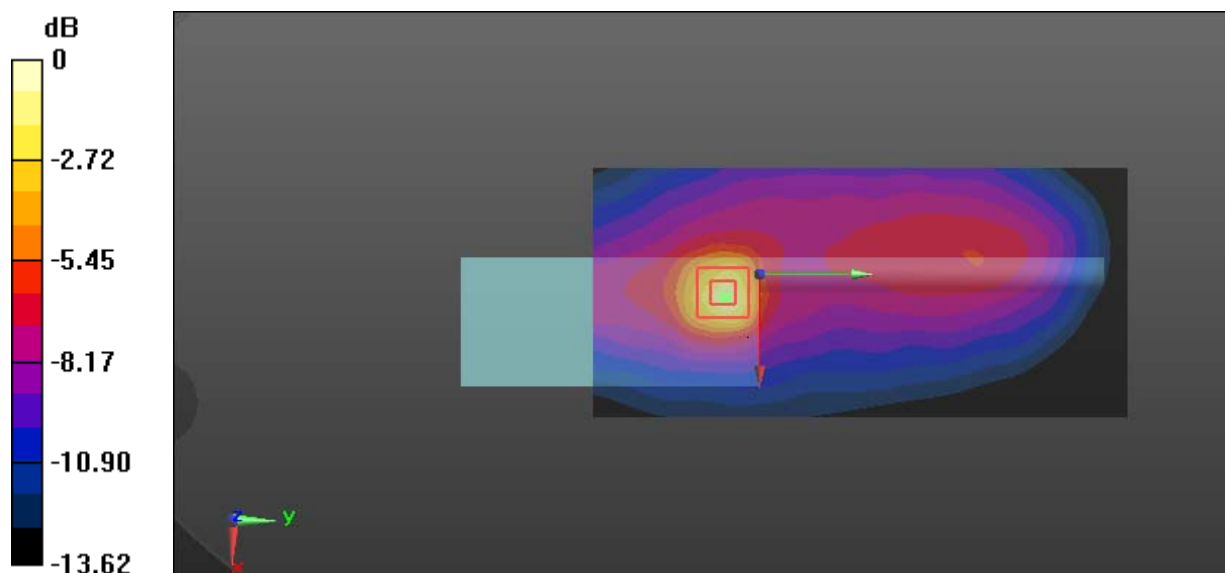

0 dB = 10.4 W/kg = 10.17 dBW/kg

Test Plot 45#: RDR4380V_PTT_4FSK 12.5kHz_Body Back_147.0125 MHz**DUT: Digital Two-Way Radio; Type: RDR4380V; Serial: 18030800428**

Communication System: 4FSK; Frequency: 147.012 MHz; Duty Cycle: 1:2

Medium parameters used: $f = 147.012$ MHz; $\sigma = 0.809$ S/m; $\epsilon_r = 61.605$; $\rho = 1000$ kg/m³

Phantom section: Flat Section

DASY5 Configuration:

- Probe: EX3DV4 - SN7329; ConvF(12.56, 12.56, 12.56); Calibrated: 2018/1/22;
- Sensor-Surface: 1.4mm (Mechanical Surface Detection)
- Electronics: DAE4 Sn1459; Calibrated: 2017/9/15
- Phantom: ELI v8.0; Type: QDOVA004AA; Serial: 2051
- Measurement SW: DASY52, Version 52.8 (8);

Area Scan (71x151x1): Interpolated grid: dx=1.500 mm, dy=1.500 mm

Maximum value of SAR (interpolated) = 4.24 W/kg

Zoom Scan (5x5x7)/Cube 0: Measurement grid: dx=8mm, dy=8mm, dz=5mm

Reference Value = 38.89 V/m; Power Drift = 0.00 dB

Peak SAR (extrapolated) = 9.41 W/kg

SAR(1 g) = 2.75 W/kg; SAR(10 g) = 1.46 W/kg

Maximum value of SAR (measured) = 5.33 W/kg

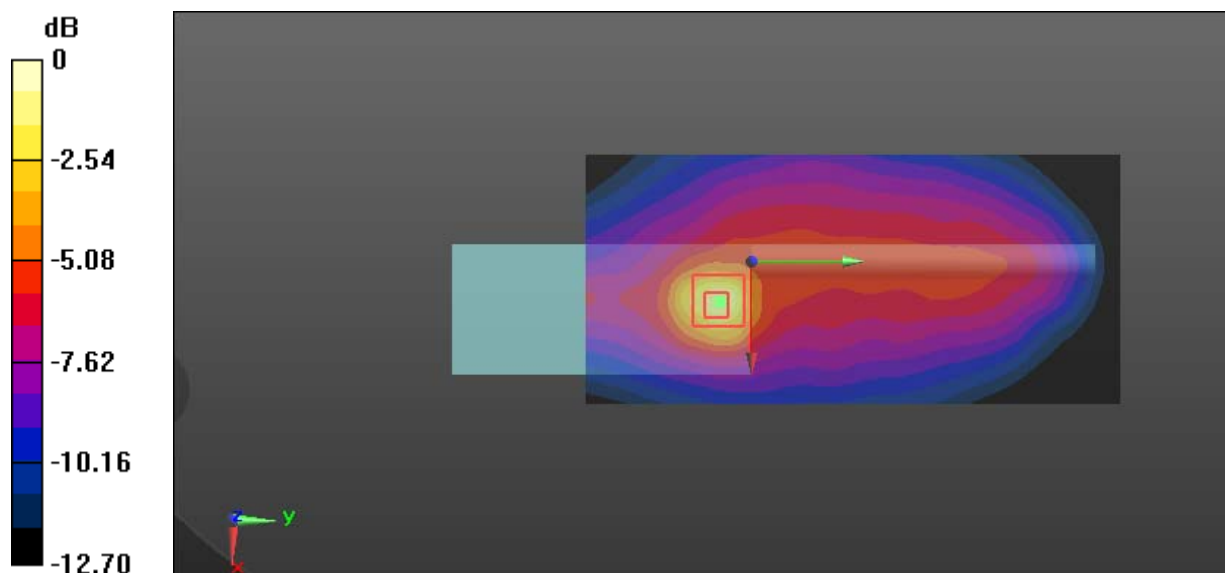

Test Plot 46#: RDR4380V_PTT_4FSK 12.5kHz_Body Back_160.0125 MHz**DUT: Digital Two-Way Radio; Type: RDR4380V; Serial: 18030800428**

Communication System: 4FSK; Frequency: 160.012 MHz; Duty Cycle: 1:2

Medium parameters used: $f = 160.012$ MHz; $\sigma = 0.825$ S/m; $\epsilon_r = 60.794$; $\rho = 1000$ kg/m³

Phantom section: Flat Section

DASY5 Configuration:

- Probe: EX3DV4 - SN7329; ConvF(12.56, 12.56, 12.56); Calibrated: 2018/1/22;
- Sensor-Surface: 1.4mm (Mechanical Surface Detection)
- Electronics: DAE4 Sn1459; Calibrated: 2017/9/15
- Phantom: ELI v8.0; Type: QDOVA004AA; Serial: 2051
- Measurement SW: DASY52, Version 52.8 (8);

Area Scan (71x151x1): Interpolated grid: dx=1.500 mm, dy=1.500 mm

Maximum value of SAR (interpolated) = 2.23 W/kg

Zoom Scan (5x5x7)/Cube 0: Measurement grid: dx=8mm, dy=8mm, dz=5mm

Reference Value = 31.06 V/m; Power Drift = -0.07 dB

Peak SAR (extrapolated) = 4.29 W/kg

SAR(1 g) = 1.44 W/kg; SAR(10 g) = 0.801 W/kg

Maximum value of SAR (measured) = 2.73 W/kg

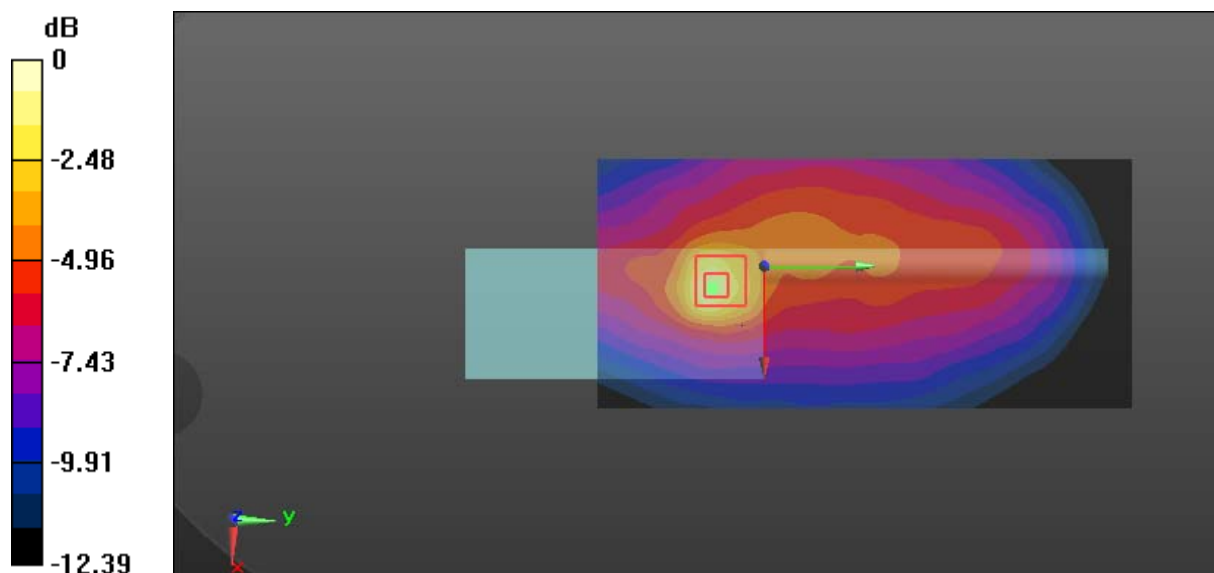

0 dB = 2.73 W/kg = 4.36 dBW/kg

Test Plot 47#: RDR4380V_PTT_FM 12.5kHz_Body Back_136.0125 MHz Headset 1**DUT: Digital Two-Way Radio; Type: RDR4380V; Serial: 18030800428**

Communication System: FM; Frequency: 136.012 MHz; Duty Cycle: 1:1

Medium parameters used: $f = 136.012$ MHz; $\sigma = 0.792$ S/m; $\epsilon_r = 62.278$; $\rho = 1000$ kg/m³

Phantom section: Flat Section

DASY5 Configuration:

- Probe: EX3DV4 - SN7329; ConvF(12.56, 12.56, 12.56); Calibrated: 2018/1/22;
- Sensor-Surface: 1.4mm (Mechanical Surface Detection)
- Electronics: DAE4 Sn1459; Calibrated: 2017/9/15
- Phantom: ELI v8.0; Type: QDOVA004AA; Serial: 2051
- Measurement SW: DASY52, Version 52.8 (8);

Area Scan (71x151x1): Interpolated grid: dx=1.500 mm, dy=1.500 mm

Maximum value of SAR (interpolated) = 9.44 W/kg

Zoom Scan (5x5x7)/Cube 0: Measurement grid: dx=8mm, dy=8mm, dz=5mm

Reference Value = 46.89 V/m; Power Drift = 0.04 dB

Peak SAR (extrapolated) = 19.5 W/kg

SAR(1 g) = 5.54 W/kg; SAR(10 g) = 2.71 W/kg

Maximum value of SAR (measured) = 11.3 W/kg

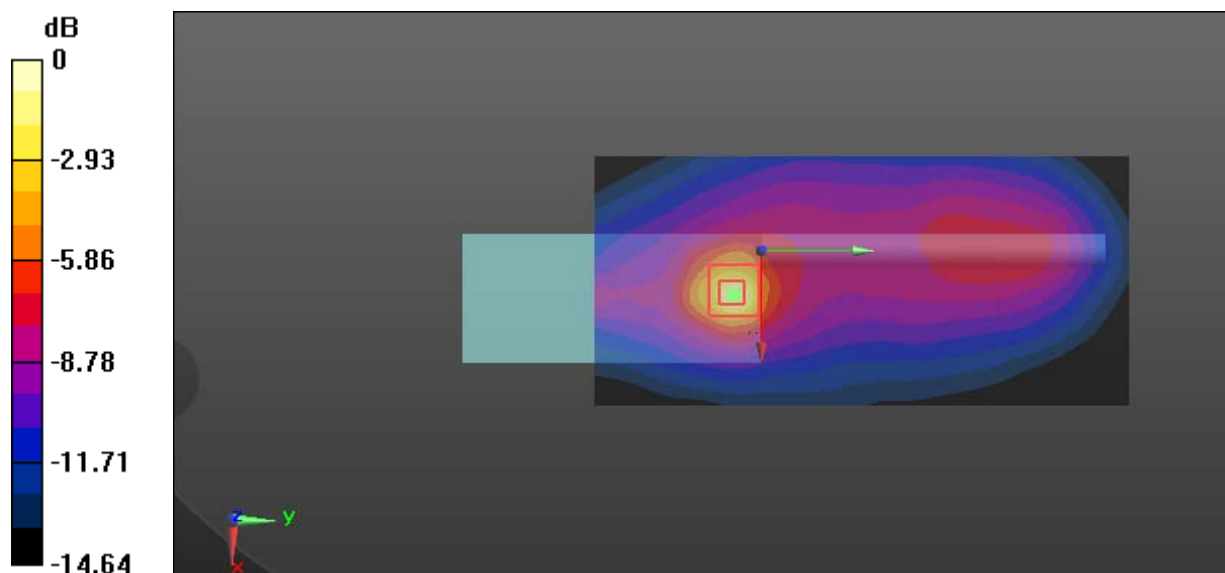

0 dB = 11.3 W/kg = 11.53 dBW/kg

Test Plot 48#: RDR4380V_PTT_FM 12.5kHz_Body Back_136.0125 MHz Headset 2**DUT: Digital Two-Way Radio; Type: RDR4380V; Serial: 18030800428**

Communication System: FM; Frequency: 136.012 MHz; Duty Cycle: 1:1

Medium parameters used: $f = 136.012$ MHz; $\sigma = 0.792$ S/m; $\epsilon_r = 62.278$; $\rho = 1000$ kg/m³

Phantom section: Flat Section

DASY5 Configuration:

- Probe: EX3DV4 - SN7329; ConvF(12.56, 12.56, 12.56); Calibrated: 2018/1/22;
- Sensor-Surface: 1.4mm (Mechanical Surface Detection)
- Electronics: DAE4 Sn1459; Calibrated: 2017/9/15
- Phantom: ELI v8.0; Type: QDOVA004AA; Serial: 2051
- Measurement SW: DASY52, Version 52.8 (8);

Area Scan (71x151x1): Interpolated grid: dx=1.500 mm, dy=1.500 mm

Maximum value of SAR (interpolated) = 12.9 W/kg

Zoom Scan (5x5x7)/Cube 0: Measurement grid: dx=8mm, dy=8mm, dz=5mm

Reference Value = 58.10 V/m; Power Drift = -0.10 dB

Peak SAR (extrapolated) = 20.8 W/kg

SAR(1 g) = 5.83 W/kg; SAR(10 g) = 3.03 W/kg

Maximum value of SAR (measured) = 11.8 W/kg

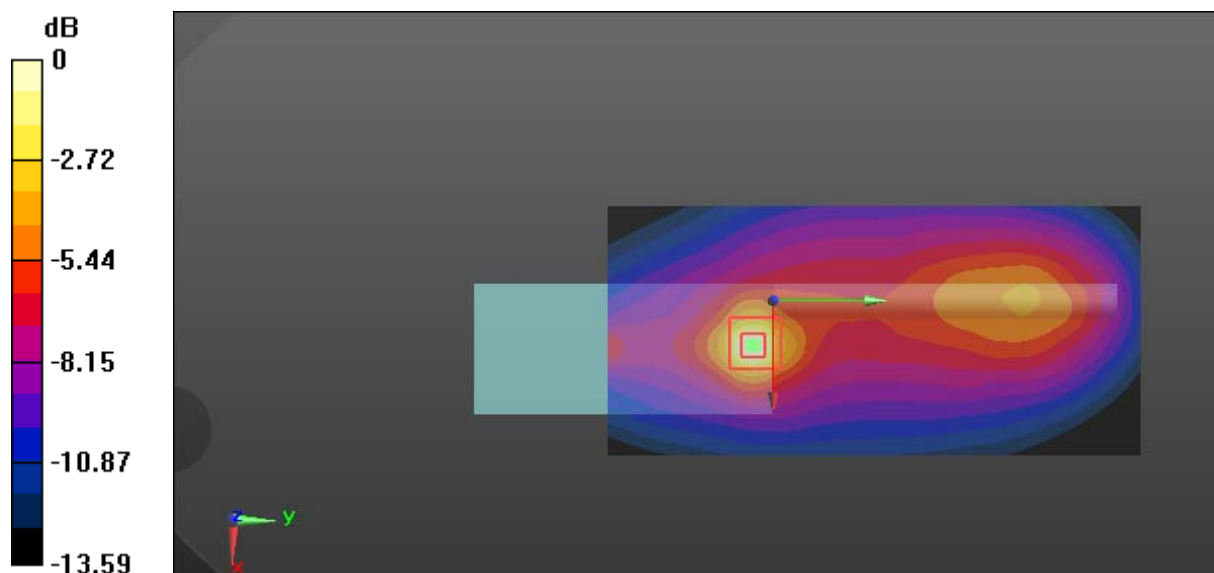

0 dB = 11.8 W/kg = 10.72 dBW/kg