

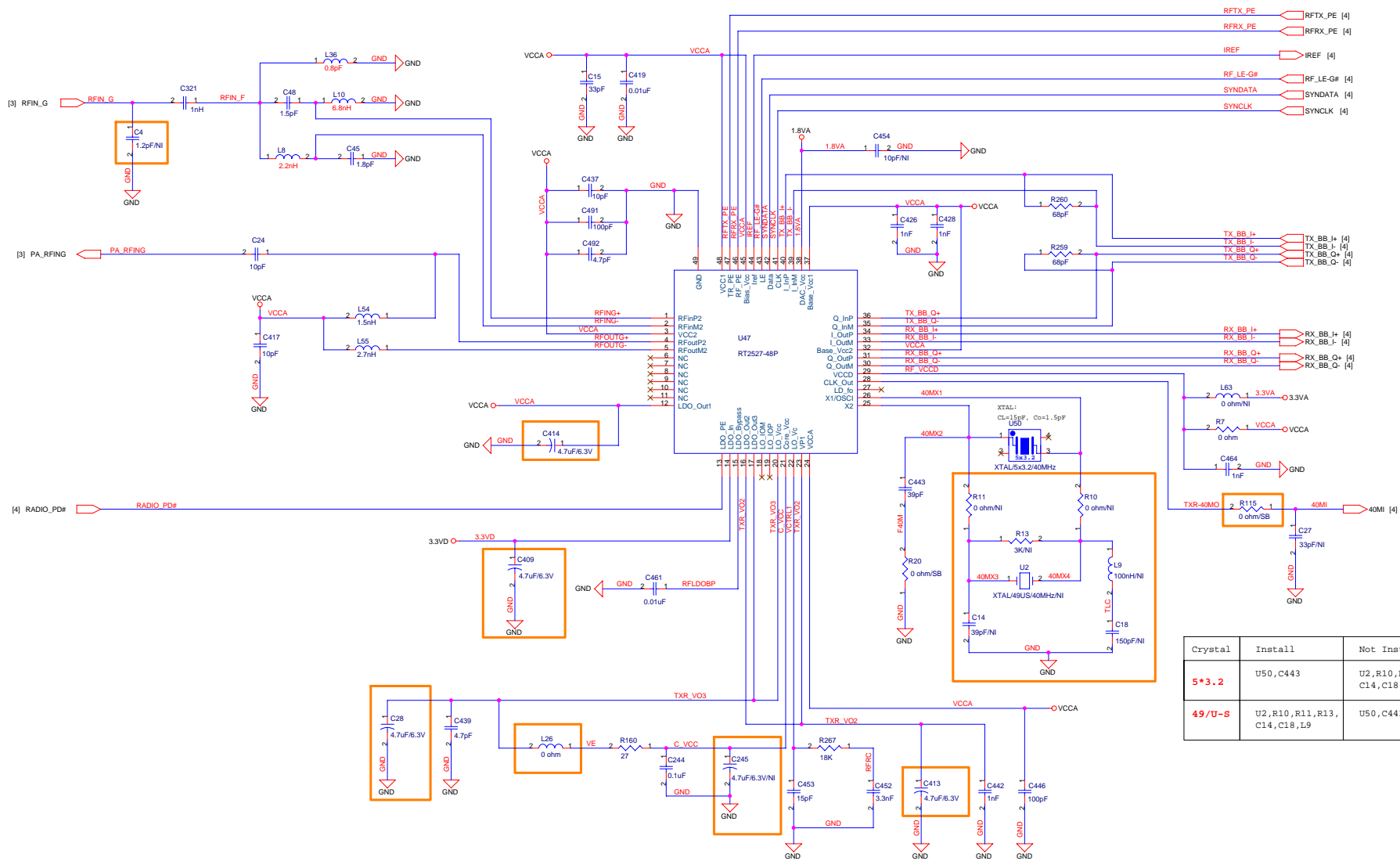

Filename:
MPCI-RT2561-RT2527-V20ST-X-060417.DSN

	RALINK TECHNOLOGY, CORP.	
	Title Mini PCI System - RT2561 + RT2527	
Size B	Document Number MPCI-RT2561+RT2527-V20ST-X.SCH	Rev 2.0
Date: Monday, April 17, 2006	Sheet 1	of 6



Crystal	Install	Not Install
5*3.2	U50, C443	U2, R10, R11, R13, C14, C18, L9
49/U-S	U2, R10, R11, R13, C14, C18, L9	U50, C443

RALINK TECHNOLOGY, CORP.
CONFIDENTIAL

	RALINK TECHNOLOGY, CORP.	
	File Transceiver - RT2527	
Size C	Document Number 1-RT2527-XTAL.SCH	Rev 2.0
Date Thursday, April 20, 2006	Sheet 2 of 6	

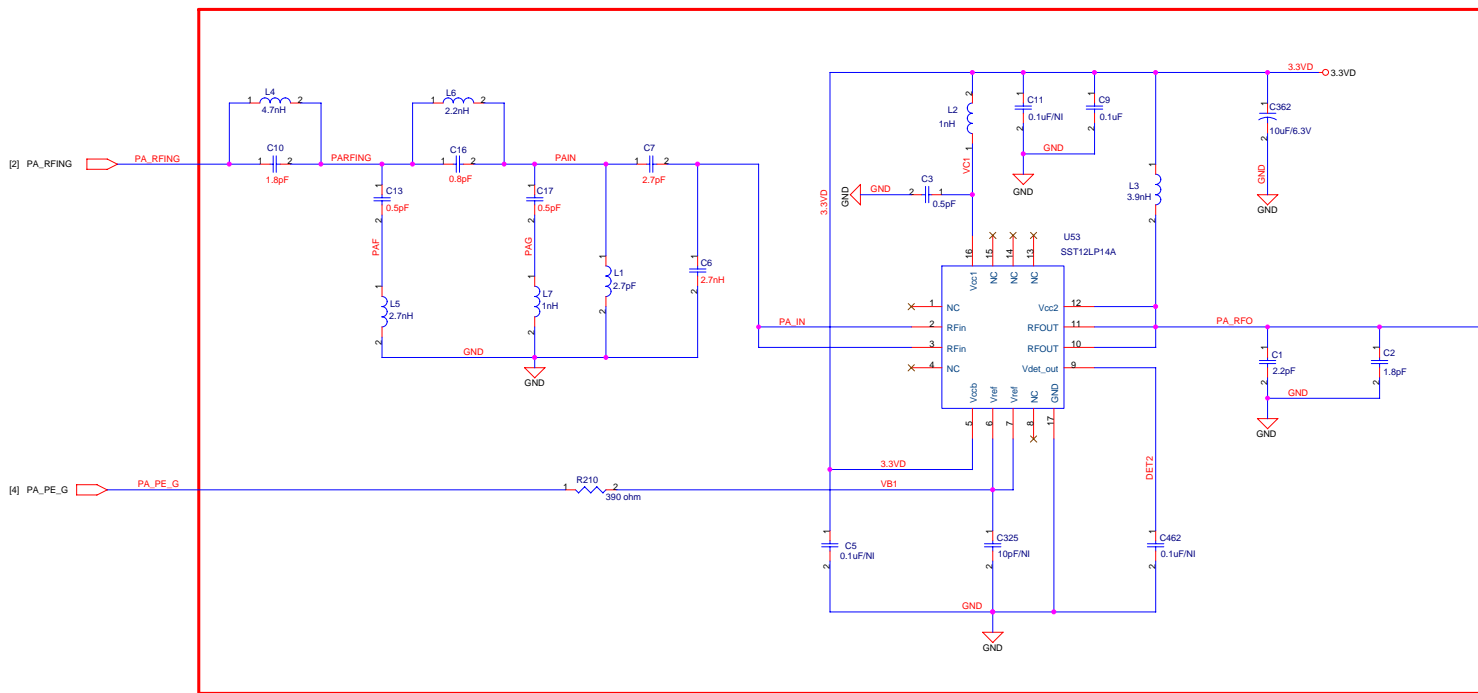
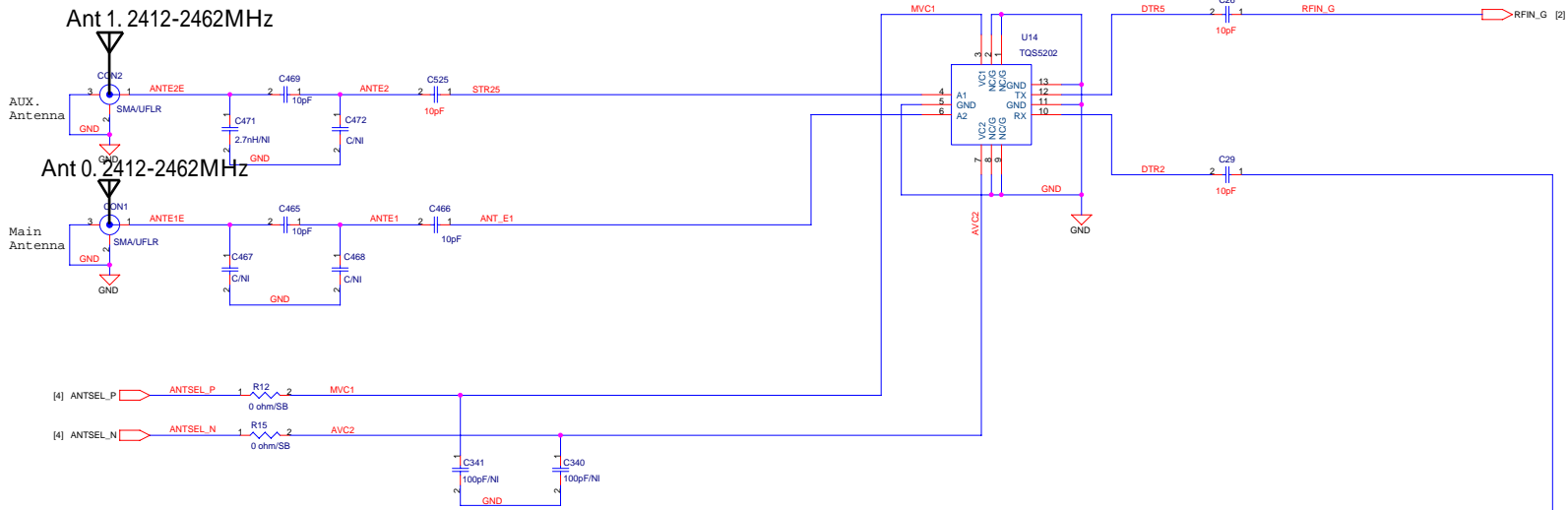

RALINK TECHNOLOGY, CORP.
CONFIDENTIAL

	RALINK TECHNOLOGY, CORP.	
	File	PA and TX/RX
Size	Document Number	Rev
C	2-PA-SST12LP14A.SCH	2.0
Date	Thursday, April 20, 2006	Sheet 3 of 6

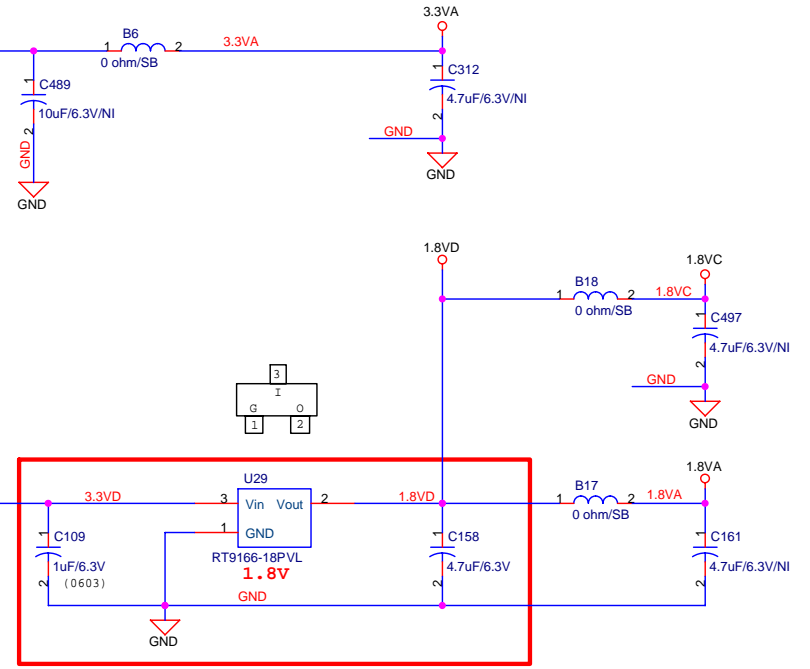
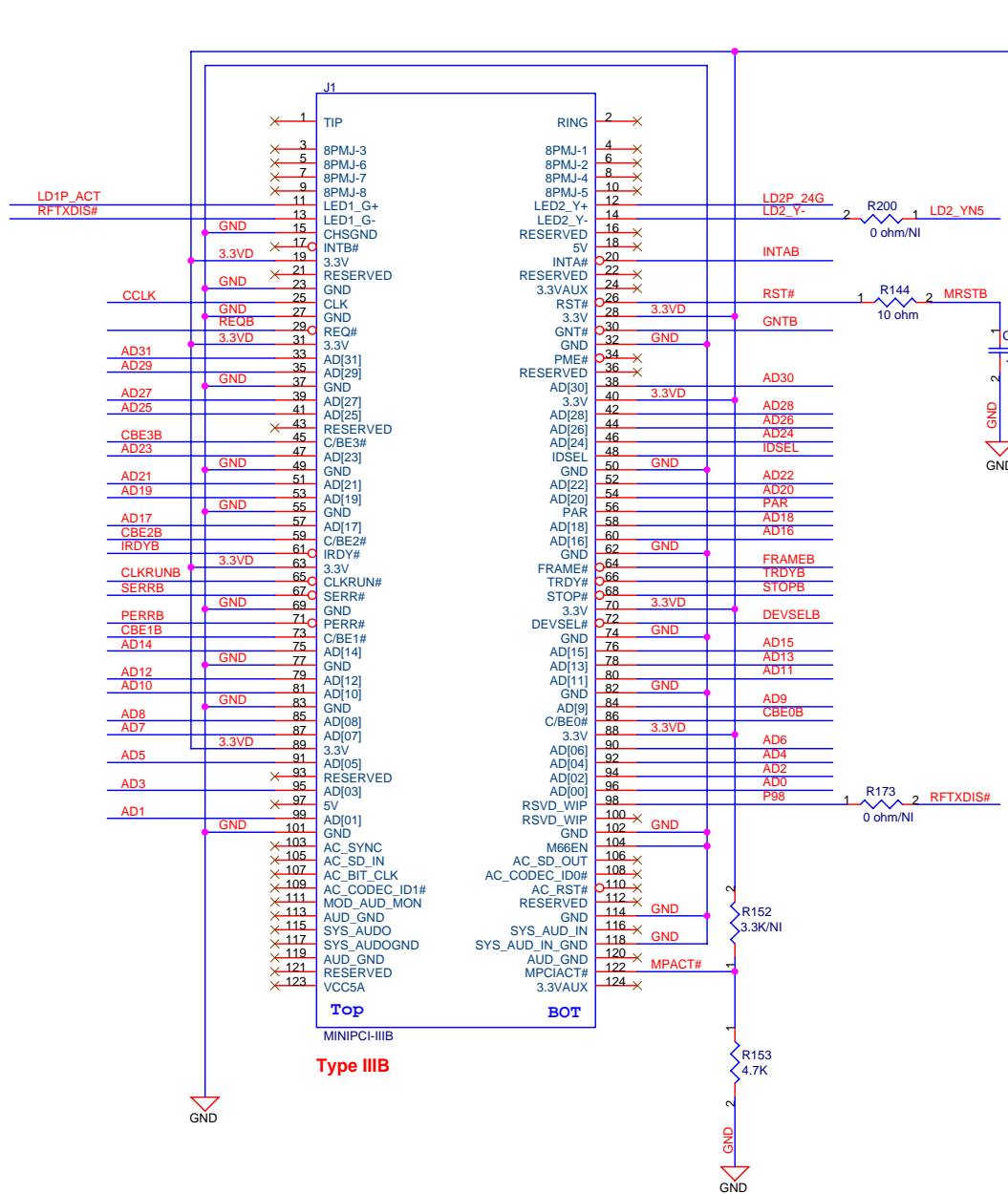

- RFTXDIS# [4]
- GNTB [4]
- REQB [4]
- MRSTB [4]
- AD[0..31] [4]
- CBE0B [4]
- CBE1B [4]
- CBE2B [4]
- CBE3B [4]
- PAR [4]
- TRDYB [4]
- IRDYB [4]
- LD1P_ACT [4]
- LD2P_24G [4]
- LD2_YN5 [4]
- INTAB [4]
- IDSEL [4]
- STOPB [4]
- DEVSELB [4]
- PERRB [4]
- FRAMEB [4]
- SERRB [4]
- CCLK [4]
- CLKRUNB [4]

Top
MINIPCI-IIIB
Type IIIB

RALINK TECHNOLOGY, CORP.
CONFIDENTIAL

		RALINK TECHNOLOGY, CORP.	
		Title Mini PCI Interface and Power	
Size B	Document Number 4-MINIPCI.SCH	Rev 2.0	
Date Monday, April 17, 2006	Sheet 5		of 6

